

NOTICE WARNING CONCERNING COPYRIGHT RESTRICTIONS:

The copyright law of the United States (title 17, U.S. Code) governs the making of photocopies or other reproductions of copyrighted material. Any copying of this document without permission of its author may be prohibited by law.

**Redesign of Stamped Products
For Improved Manufacturability**

by

J.T.V. de Castro and S. Desa

EDRC-24-06-88

UNIVERSITY LIBRARY
CARNEGIE-MEYON UNIVERSITY
PITTSBURGH, PENNSYLVANIA 15261

Redesign of Stamped Products

For Improved Manufacturability

Jose Tadeo V. de Castro
Research Assistant

Subhas Desa
Assistant Professor

18 March 1988
Department of Mechanical Engineering
Carnegie Mellon University
Pittsburgh, PA 15213

ABSTRACT

This paper describes an approach developed for evaluating the manufacturability of a stamped product. Based on this evaluation, recommendations are made for the redesign of the product for improved manufacturability. The approach is applied to the metal stamping domain and the implementation of this approach in a computer-based environment is discussed. The following activities, described in this paper, were performed to achieve the research objectives:

1. acquisition of domain knowledge and understanding of the stamping process,
2. development of an expert system which evaluates the manufacturability of a complex stamped product; and
3. development of the capability to represent stamped products in a CAD solid modelling system and to extract high-level information.

Several examples are discussed to demonstrate the applicability as well as the limitations of this current approach.

Table of Contents

1 OBJECTIVES AND PLAN OF THE RESEARCH	1
2 RESEARCH ACTIVITIES	2
3 THE STRUCTURE OF THE MANUFACTURING KNOWLEDGE	3
4 PROGRESS AND CURRENT CAPABILITIES OF THE PROJECT	3
5 FUTURE WORK	4
6 ACKNOWLEDGEMENTS	5
7 REFERENCES	6
8 APPENDIX	9

INTRODUCTION

The design of engineering products for improved manufacturability is an issue of major concern today. In the present context, improved manufacturability generally implies either designing or redesigning the product to reduce costs. In this report we will address design for manufacturability in the stamping domain.

The report is organized as follows. We first describe the general and specific objectives of the project and the overall plan to accomplish these objectives (section 1). In section 2 we describe specific research activities which were carried out to meet these objectives. The structure and representation of knowledge in the stamping domain is described in section 3. In the next section (section 4) the current status and capabilities of the project are discussed. Several examples are given which clearly reveal both the capabilities and limitations of the current approach. In section 5 we discuss future directions.

The details of the examples and supporting work are given in the Appendix.

1 OBJECTIVES AND PLAN OF THE RESEARCH

The general objectives of the research are the following:

1. To develop methods for evaluating the manufacturability of a product design. These methods would allow us to bring manufacturing concerns into the early stages of the design process.
2. To develop methods for comparing the manufacturability of alternative product designs in order to select the most cost-effective design.
3. To develop computer-based environments to evaluate and compare the manufacturing of alternative designs. Central to the development of these environments is the appropriate representation of the design and the structuring and representation of the manufacturing process to facilitate design evaluation.
4. To realize the above objectives in the stamping domain.

As a first step to meeting the general objectives, we are building a computer-based environment which could take a complex stamping, like the IC Lead-Frame shown in Example 5 of Appendix A, and evaluate its manufacturability.

Our current approach is to evaluate the manufacturability of stamped components using a set of rules (Figure 1 shows a typical rule. Appendix B illustrates more stamping rules.). The satisfaction of the appropriate set of rules ensures that the part can be economically stamped. If a rule is violated then, in general, the cost of producing the stamping (in question) would be very high.

It is extremely important that the rules be logically and systematically organized: the structuring of the stamping process and knowledge in order to achieve this is described in section 3.

A computer-based environment for evaluating the manufacturing of stamped products will have the following modules.

1. A Geometric Reasoning CAD System, capable of taking a CAD description of a part and extracting relevant "high-level" information (for example features [2,3]) and data which allow one to evaluate the manufacturability of the system.
2. An Expert System which operates on the "higher-level" information and data produced by the Geometric Reasoner and assesses the manufacturability of the stamped product based

on the set of rules described above.

3. A Process Planner which generates a process plan in order to manufacture the stamped component (which is being analyzed). This is essential for comparing alternative designs.
4. A Cost Modeller which, in conjunction with the process planner, allows one to compare alternative designs and select the most cost-effective.

Our current work concentrates on modules 1 and 2 above, viz., The Geometric Reasoner and the Expert System.

A schematic of the computer-environment for evaluating the manufacturability of stamped products (called the MANUFACTURABILITY EVALUATOR, for short), which incorporates the Geometric Reasoner and the Expert System, is shown in Figure 1; also shown in this figure is how the Evaluator would analyze a very simple stamping for manufacturability.

2 RESEARCH ACTIVITIES

Towards developing an Evaluator for assessing the manufacturability of stamped products we spent time on the following activities:

1. ACQUISITION OF KNOWLEDGE AND UNDERSTANDING OF THE STAMPING PROCESS.

This was acquired in two ways:

- a. detailed discussions with manufacturing engineers at Oberg Manufacturing Company, Freeport, PA. Oberg is a local company which has an international reputation in the production of precision stamped products. (Example 5 in Appendix A is a typical stamping produced by Oberg).
- b. studying the existing literature (articles, textbooks and handbooks) on the design of stamped products and the stamping process itself.

2. DEVELOPMENT OF AN EXPERT SYSTEM WHICH EVALUATES THE MANUFACTURABILITY OF A COMPLEX STAMPED PRODUCT.

We have spent a considerable amount of time structuring the knowledge acquired above in order to produce a knowledge-based expert system which evaluates the manufacturing of a stamped component. Since the structuring of the knowledge allows us to create a systematic and ordered set of rules, we explain it in some detail in the following section.

We would like to emphasize that all of the activities described above were relatively new to us and therefore much time was spent in "learning."^{1*}

3. DEVELOPMENT OF THE CAPABILITY TO REPRESENT STAMPED PRODUCTS in a CAD Solid Modelling System and extract high-level information.

- a. Here we have made use of the solid modelling package (DFMSOLID) developed at the Design for Manufacturability Laboratory EDRC, as a basis for our Geometric Reasoner. Programs were written to extract the data needed for our purpose from this CAD modeller.

3 THE STRUCTURE OF THE MANUFACTURING KNOWLEDGE

The structure of the knowledge of the stamping process is crucial to the development of a systematic and ordered set of rules for evaluating manufacturing.

The following META-RULES were used to structure the stamping process (see Figure 2).

1. The primary stamping operations are either Material Removal or Material Forming.
2. Each primary operation comprises several secondary operations. These are enumerated in Figure 2.
3. Each secondary operation produces certain features on the part which is being stamped. (Therefore there is a well defined mapping between secondary operations and features).
4. To be (economically) manufacturable each feature must satisfy certain relationships which are imposed by the operation which produces it (i.e. the feature). These relationships might also be called manufacturing constraints and are expressed in the form of rules. (A typical rule is shown in Figure 1. More stamping design rules are illustrated in Appendix B.).

The rules themselves are broken into two levels:

Level 1: rules characterizing individual features

Level 2: rules characterizing feature interactions

(In addition, we might have a third level of rules relating to the sequencing of operations).

Based on the above structure of the stamping process we obtain the following META-RULES which drive the Expert System:

1. Given a part which is to be stamped, decompose the part into features that are produced by the secondary operations enumerated in Figure 2. For each feature, invoke the rule which describes the manufacturing constraint imposed on the feature by the secondary manufacturing operation which produces it.
2. A complex part is composed of interacting features. First analyze each feature individually. Then identify possible feature interactions using a "feature-map."¹¹ Once feature interactions are established, the appropriate rules which govern the interaction are invoked.

The detailed set of rules for evaluating the manufacturing of stamped parts are given in Appendix C.

4 PROGRESS AND CURRENT CAPABILITIES OF THE PROJECT

Our current capabilities are best described in terms of the 5 examples give in the Appendix. Each example is appropriately annotated.

Specifically we are able to do the following:

1. Represent stamped products in the CAD data base and extract features using the Geometric Reasoner. At this time we are able to locate various planar features and extract key information from these features, while putting no burden of feature flagging on the designer. Examples 1, 2 and 3 demonstrate typical stampings which we can handle and also show the kind of features which we can extract.
2. We have a Rule-Based Expert System, based on the structure described in section 3, which can evaluate fairly complex 2-D and 3-D stampings with "well-defined" features. The expert system currently interacts with information fed by the user. This information, which consists

of individual feature characteristics and feature interactions, is obtained through a dialog between the designer and the expert system.

Example 4 is a typical example of a complex 3-D stamping which can be successfully evaluated using the Expert System. We have also included the dialog between the Expert System and the designer. Both individual features and feature interactions are analyzed.

In the case of Example 5, the expert system runs into difficulty because the features are not -well-defined."

3. We have developed the Geometric Reasoner and Expert System independently and in parallel. In the next few weeks we plan to integrate the two to create the MANUFACTURING EVALUATOR.

We have already tested the feasibility of combining geometric reasoning with simple rules for evaluating manufacturing for the relatively simple stampings of Examples 1 and 2.

4. The expert system can handle feature interactions because a feature-map is created based on the proximities of individual features. The feature interactions, established in the feature-map, are then subjected to the stamping design rules to evaluate the whole part's manufacturability. This is demonstrated in Example 4.
5. For the stamping process we have developed reasonable representations of the product and the stamping process which enable the manufacturing of the product to be assessed.

5 FUTURE WORK

Our current short term objective is to integrate the Geometric Reasoner and the Expert System in order to be able to evaluate the manufacturability of complex stampings with well-defined features (such as Example 4) directly from a CAD data base.

Neither the Geometric Reasoner nor the Expert System can handle features which are not "well-defined" such as those which make up the IC Lead-Frame of Example 5. Therefore we need to either define a richer and more complex set of features or allow the user to define special features which are pertinent to his or her design.

Currently we can determine whether a given design is manufacturable; while this is an important first step, we need to be able to compare alternative candidate designs in order to select the "best" design.

Finally we need to be able to deal with assemblies of stamped components.

One of our long term future objectives would be to develop a DESIGN FOR STAMPING^{1*} computer-environment which would be able to evaluate and compare several design alternatives of complex stamped products in order to select the most cost-effective design. In order to successfully complete our work we will need to closely interact with the other groups in the DFM Laboratory, in particular the Geometric Reasoning Group, the Injection Molding Group and the "Cost-Analysis* Group.

6 ACKNOWLEDGEMENTS

1. Mr. Jim Schmitz has recently joined the **project and contributed to the development of the computer-based system.**
2. **Mr. Harry Walters and Mr. Wes Elliott from Oberg Manufacturing Company provided the expertise and knowledge for the progressive stamping domain.**

7 REFERENCES

CITED:

- [1] Bralla, J. G. [Ed.]
Handbook of Product Design for Manufacturing:
A practical guide to low-cost production
McGraw-Hill, New York, 1986.
- [2] Cunningham, J. J., and J. R. Dixon
Designing with Features: The Origin of Features
1988 ASME Computers in Engineering Conference, San Francisco, July 1988.
- [3] Luby, S. C., J. R. Dixon, and M. K. Simmons,
Designing with Features: Creating and Using a Features Database
for Evaluation of the Manufacturability of Castings,
Proceedings of the Computers in Engineering Conference, Chicago, July 1986.
- [4] Pahl, G., and W. Beitz
Engineering Design, First English Edition,
The Design Council, London, 1984.
- [5] Strasser, F.,
Practical Design of Sheet Metal Stampings, First Ed.
Chilton Company, 1959.

UNCITED:

- Strasser, F.,
Functional Design of Metal Stampings, First Ed.
Society of Manufacturing Engineers, 1971.
- Keyes, K. A. [Ed],
Pressworking: Stampings and Dies, First Ed.
Society of Manufacturing Engineers, 1980.
- Keyes, K. A. [Ed],
Innovations in Die Design, First Ed.
Society of Manufacturing Engineers, 1982.

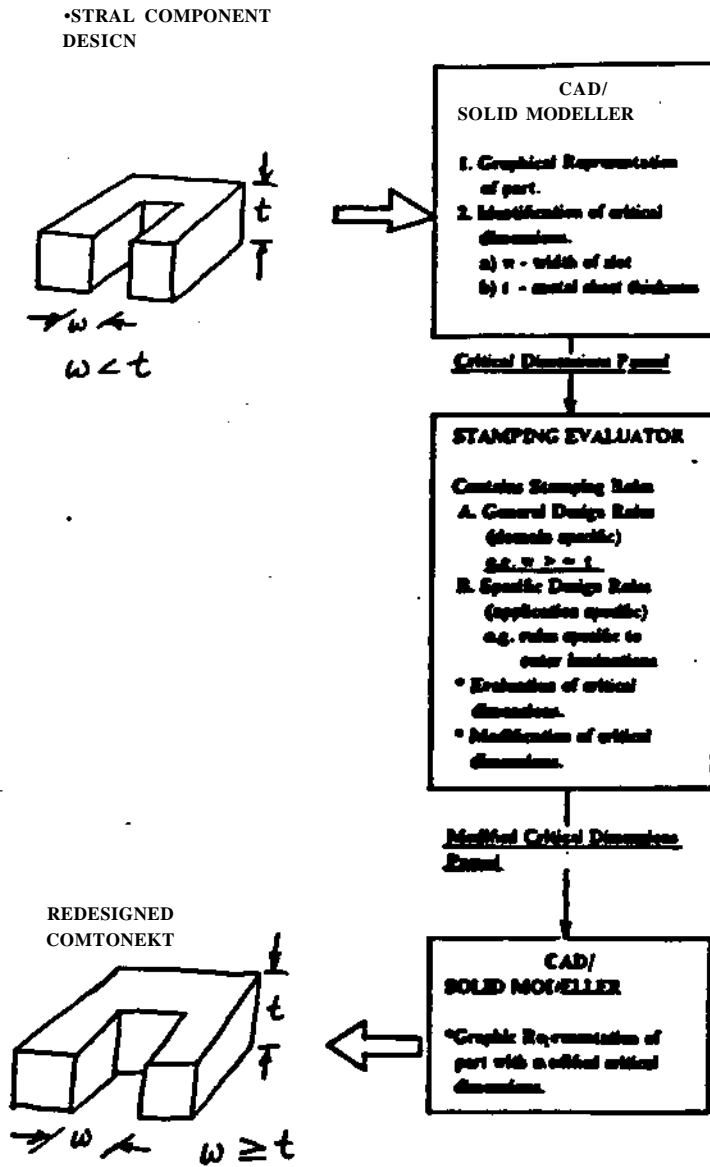
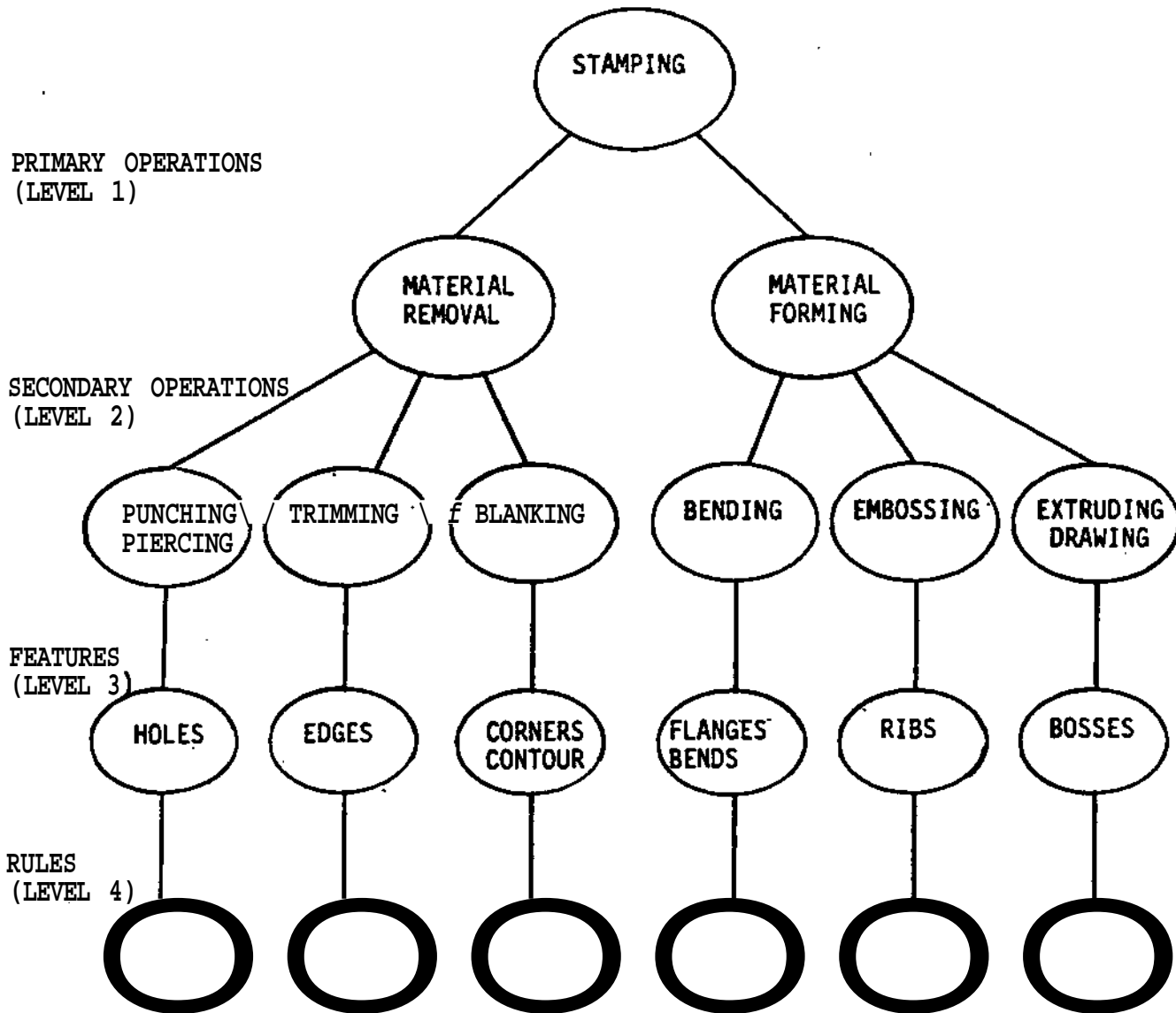

Figure 1. The Manufacturability Evaluator



SAMPLE RULES:

- * Hole diameters must be greater than or equal to sheet thickness.
- * Rounding radii for bends must be greater than or equal to 0.5 times the sheet thickness.

Figure 2. The Structure of the Stamping Process

8 APPENDIX

Appendix A: Examples

Example 1: Feature Extraction and Manufacturability Evaluation of a Stamping with a Slot

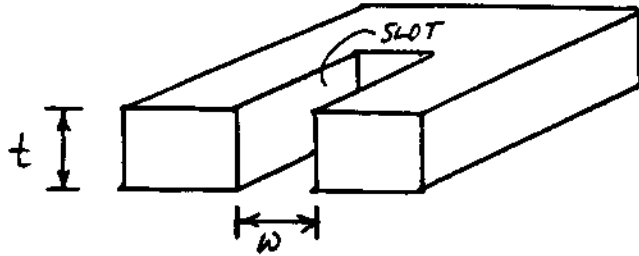

Comment: If $w < t$, the stamping is not manufacturable and must be redesigned.

Example 2: Feature Extraction and Manufacturability Evaluation of a More Complex Part

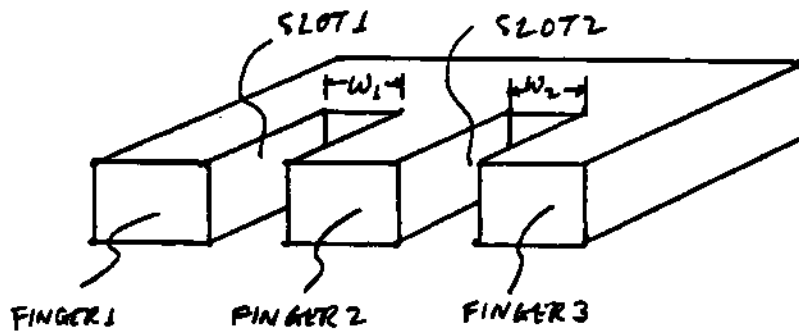

Example 3: Feature Extraction (CAD System) of a Complex Part with Multiple Features

Note: The Features Extracted are Labelled

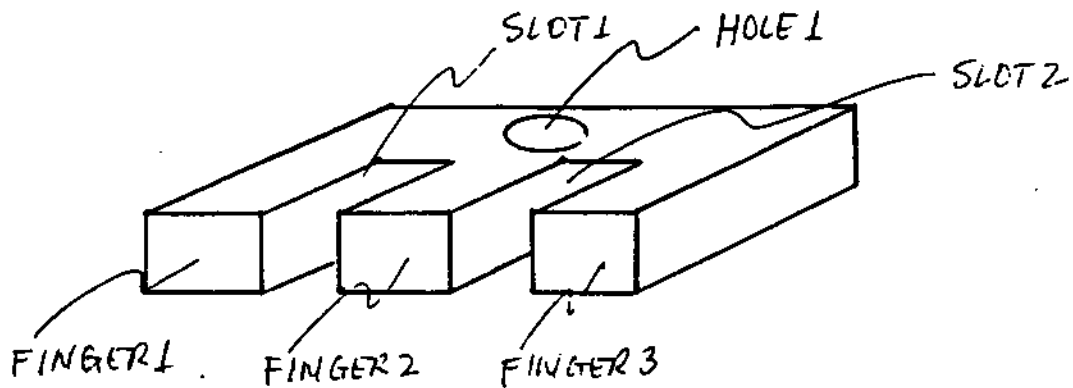

Example 4: Manufacturability Evaluation of a Complex 3-D Stamping with Multiple (But Simple) Features

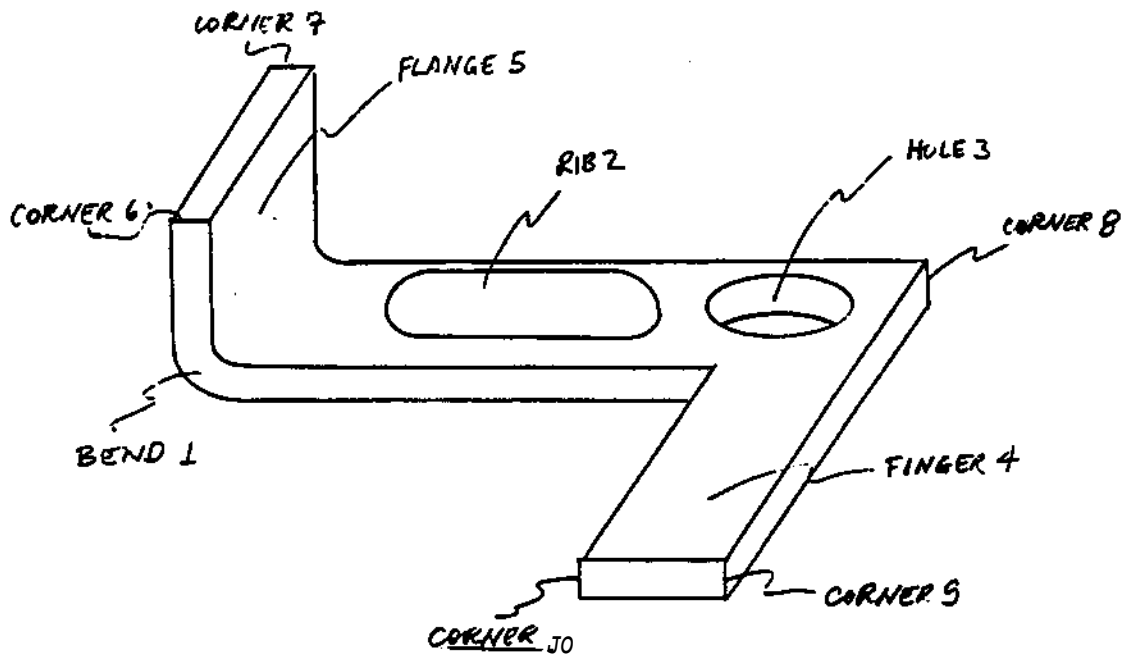

Note: The dialogue between the designer and the manufacturability evaluator is given on the following pages.

Example 5 I-C Lead Frame Stamping

- 1) This represents a typical complex 2-D stamping.
- 2) The expert system has difficulty with feature definition in this case.

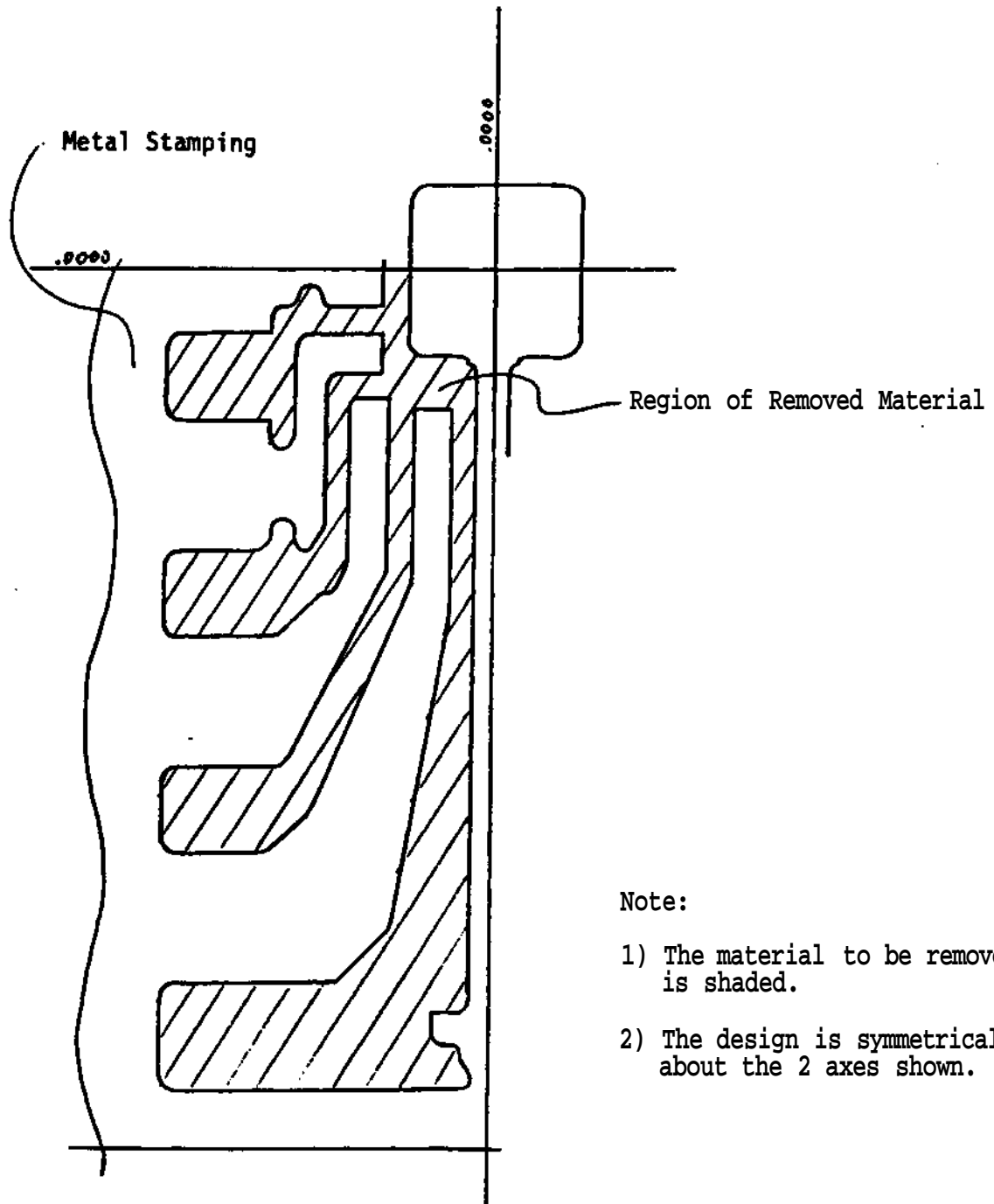

Dialog between the manufacturability evaluator and the design for Example 4.

SAMPLE RUN

OPS5>(run)

Enter the following information on the stock strip:

1) What is the stock hardness?
answers corresponding values

1soft

2medium

3hard

Please input the number corresponding to your choice: 2

2) What is the material thickness?
0.699

Are there any features left to enter? (yes or no) yes

Enter the feature name and label:
bend 1

Are there any features left to enter? (yes or no) yes

Enter the feature name and label:
rib 2

Are there any features left to enter? (yes or no) yes

Enter the feature name and label:
hole 3

Are there any features left to enter? (yes or no) yes

Enter the feature name and label:
finger 4

Are there any features left to enter? (yes or no) yes

Enter the feature name and label:
flange 5

Are there any features left to enter? (yes or no) yes

Enter the feature name and label:
corner 6

Are there any features left to enter? (yes or no) yes

Enter the feature name and label:
corner 7

Are there any features left to enter? (yes or no) yes

Enter the feature name and label:
corner 8

Are there any features left to enter? (yes or no) yes

Enter the feature name and label:
: corner 9

Are there any features left to enter? (yes or no) yes

Enter the feature name and label:
corner 10

Are there any features left to enter? (yes or no) yes

Enter the feature name and label:
corner 11

Are there any features left to enter? (yes or no) no

Enter the following information on
corner 11

1) What is the radius of curvature?
-0.01

Enter the following information on
corner 10

1) What is the radius of curvature?
0.1

Enter the following information on
corner 9

1) What is the radius of curvature?
0.01

Enter the following information on
corner 8

1) What is the radius of curvature?
0.2

Enter the following information on
corner 7

1) What is the radius of curvature?
.0.8

Enter the following information on
corner 6

1) What is the radius of curvature?
1.0

Enter the following information on
flange 5

1) What is the minimum width of this flange?

1

2) What is the minimum leg height of this flange?

0.1

Enter the following information on finger 4 :

1) What is the minimum width of this finger?

0-4

2) What is the type of this finger?

answers corresponding values

1parallel

2non-parallel

Please input the number corresponding to your choice: 1

Enter the following information on
hole 3

1) What is the shape of this hole?

answers corresponding values

1v circular

2oval

3square

4complex

Please input the number corresponding to your choice: 2

2) What is the minimum width of this hole?

0.2

Enter the following information on
rib 2

1) What is the height of this rib?

0.5

2) What is the width of this rib?

0.3

3) What is the type of this rib?

answers corresponding values

1closed

2open

Please input the number corresponding to your choice: 1

4) What is the inner radius of this rib?

0.3

5) What is the outer radius of this rib?

0.6

Enter the following information on
bend 1

1) What is the radius of curvature of this bend?

1

Type in the minimum distance between
the following two features:
rib 2 to bend 1 0.4

Type in the minimum distance between
the following two features:
hole 3 to bend 1 1.0

Type in the minimum distance between
the following two features:
rib 2 to hole 3 0.6

Type in the minimum distance from hole 3 to the outer contour: 0.5

Type in the minimum distance from rib 2 to the outer contour: 1.1

The following feature was found to violate a design rule:

Feature: rib 2
Parameter in question: width
Actual parameter value: 0.3
Recommended minimum value: 1.398
Basis for rule: sheet thickness

The following feature was found to violate a design rule:

Feature: rib 2
Parameter in question: height
Actual parameter value: 0.5
Recommended minimum value: 1.0485
Basis for rule: sheet thickness

The following feature was found to violate a design rule:

Feature: rib 2
Parameter in question: outer radius
Actual parameter value: 0.6000000000000001
Recommended minimum value: 1.0485
Basis for rule: sheet thickness

The following feature was found to violate a design rule:

Feature: rib 2
Parameter in question: inner radius
Actual parameter value: 0.3
Recommended minimum value: 0.8388000000000001
Basis for rule: sheet thickness

The following feature was found to violate a design rule:

Feature: finger 4
Parameter in question: width
Actual parameter value: 0.4
Recommended minimum value: 1.398
Basis for rule: thickness

The following feature was found to violate a design rule:

Feature: corner 9
Parameter in question: radius of curvature
Actual parameter value: 0.01
Recommended minimum value: 0.05
Basis for rule: absolute

The following feature was found to violate a design rule:

Feature: corner 11
Parameter in question: radius of curvature
Actual parameter value: -0.01
Recommended minimum value: -0.05

Basis for rule: absolute

The choice of stock material thickness is not of standard size.
It is recommended it be a multiple of 1/64 in thickness.

Actual thickness: 0.6990000000000001

The following hole is not the best shape.

The order of efficient shape, from best to worst, is circular,
oval, square, complex:

Hole 3

Current shape: oval

The following feature has parallel sides. It is recommended that
the sides be made at a 60-degree angle With respect to each other
if possible:

Feature: finger 4

The following two features are too close to each other:

Feature 1: rib 2
Feature 2: hole 3
Actual distance: 0.6
Recommended minimum distance: 13.98
Basis for rule: sheet thickness

The following two features are too close to each other:

Feature 1: rib 2
Feature 2: bend 1
Actual distance: 0.4
Recommended minimum distance: 8
Basis for rule: sheet thickness

The following two features are too close to each other:

Feature 1: rib 2
Feature 2: hole 3
Actual distance: 0.6
Recommended minimum distance: 13.98
Basis for rule: sheet thickness

The following feature is too near the outer edge:

Feature: rib 2
Actual distance: 1.1
Recommended minimum distance: 13.98
Basis for rule: sheet thickness

The following feature is too near the outer edge:

Feature: hole 3
Actual distance: 0.5
Recommended minimum distance: 1.4
Basis for rule: sheet thickness

end - explicit halt

Appendix B: Representation of Design Rules for Stamping

This section discusses two representation forms of the design rules for stamping. The Rule-Test-Prescription (RTP) form and the Operation-Rule-Objective (ORO) form are the representations we formulated and applied to structuring the design rules for stamping. The objective of these representations is to organize and structure the rules to accurately reflect the actual manufacturing constraints of the process. The RTP form characterized the main concerns of the designer and the manufacturing engineer, while the ORO form reflects the interactions of the features and the effects of sequencing of stamping operations on a stamped product's manufacturability.

Sample design rules are first presented then the representation forms are discussed.

Typical stamping rules[5] are as illustrated in the following figuresp]:

Sample Rule 1

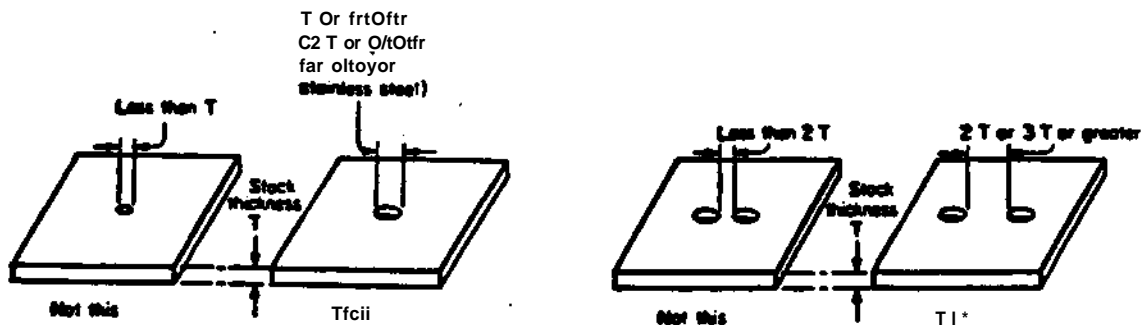

Figure 3

This rule states that hole diameters must be greater than twice the sheet thickness to be able to punch the hole, and that the distance between hole edges must be at least two to three times the sheet thickness.

Sample Rule 2

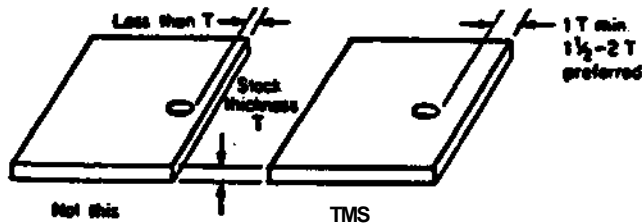

Figure 4

This rule states that the distance between the hole edge and the sheet edge must be at least one and a half to twice the sheet thickness.

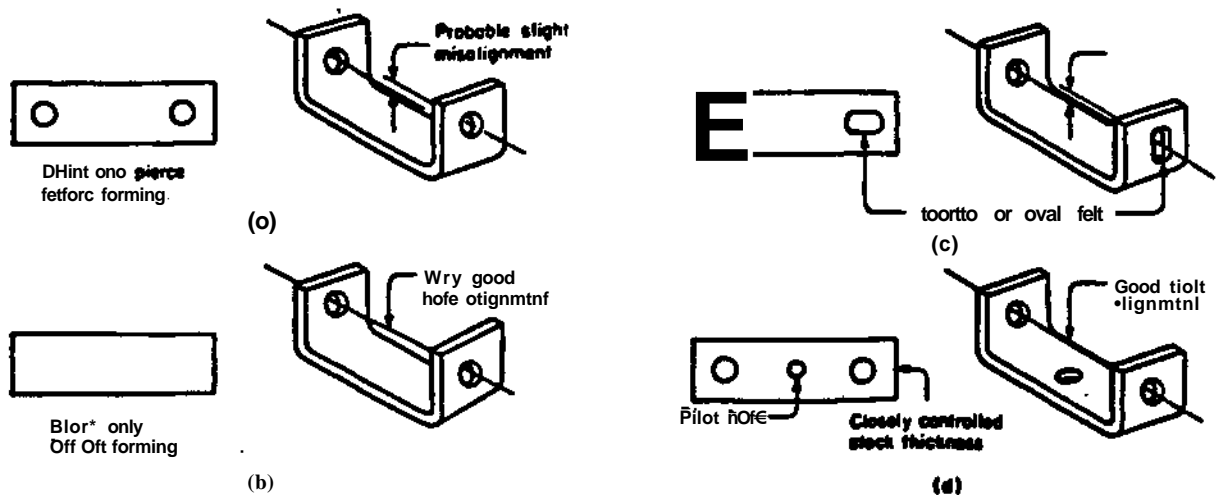

Figure 5

The first three prescriptions are direct concerns of the designer since the functional specifications will be affected. The fourth prescription states that the bending operation should precede the hole-piercing operation⁴. This is a direct concern of the manufacturing engineer since the die design is altered by the change in operation sequence. The indirect concern of the designer would be the increased cost of the stamped part due to the die becoming more complex and expensive.

The above examples illustrate the advantage of representing the design rules that have been collected in RTP form. It is important, early on to cull the rules and determine which of these can be directly applied to the domains of the designer and manufacturing engineer.

The Operation-Rule-Objective Form

The Operation-Rule-Objective form (ORO) is a modification of the RTP form of representing the rules and allows these rules to be structured such that the sequence of operations is reflected in the evaluation of the product's design. The OPERATION part of the form is the particular stamping operation involved. In our implementation these operations are limited to the indexing, piercing, bending/forming and blanking. The RULE part of the form is more like a guideline and contains the same information that the RTP form reflects, i.e. the tests are applied and the prescriptions are also made. The OBJECTIVE part identifies what the rule aims to accomplish. For example, the objective may be to reduce the part cost by either reducing material scrap or simplifying part contour outlines. Another objective would be to improve part quality by observing the limits on bend radii⁴, for example.

The Rule-Test-Prescription Form

The Rule-Test-Prescription form (RTP) was chosen as the representation form for the stamping design rules. This form has a RULE part that contains the information or knowledge as collected from the sources, the TEST part states the rule in terms of the parameters and relationships between them and the PRESCRIPTION part suggests modifications that have to be made to the product's design. The PRESCRIPTION part more importantly determines whether a design rule is a direct concern of the product designer or of the manufacturing engineer.

The RTP form can be more clearly illustrated by using this form to representing some of the above-mentioned sample rules:

Sample Rule 2:

RULE: The distance between the hole edge and the sheet edge must be at least one and a half to twice the sheet thickness.

TEST: $d > \llbracket 1.5 \text{ to } 2.0 T$
 where d - is the distance between hole edge and sheet edge
 T - is the sheet thickness

PRESCRIPTION: Reduce the hole diameter or relocate hole by increasing d.

The above is an example of a rule with a prescription that is a direct concern of the product designer since modification of hole size or location affects the functional specifications of the designer.

An example of a rule in the RTP form, wherein one of the prescriptions is a concern of the manufacturing engineer rather than a direct concern of the designer, follows.

RULE: The distance between the hole edge and a bend line must be at least one and a half times the sheet thickness. (Figure 5)

TEST: $d > \llbracket 1.5 T$
 where d - is the distance between hole edge and bend line
 T - is the sheet thickness

PRESCRIPTION:

1. Reduce the hole diameter.
2. Relocate hole by increasing d.
3. Cut notches around the hole.
4. Change the sequence of operations, i.e. bend the metal then punch the hole.

The above-mentioned sample rules can also be represented in the ORO form as follows:

For the same sample rule;

Sample Rule 2:

OPERATION: Piercing of Holes

RULE:

rule: The distance between the hole edge and the sheet edge must be at least one and a half to twice the sheet thickness.

test: $d \geq 1.5 \text{ to } 2.0 T$

where d - is the distance between hole edge and sheet edge
 T - is the sheet thickness

prescription: Reduce the hole diameter or relocate hole by increasing d .

OBJECTIVE: To increase the quality of stamped product by ensuring that the edge is not bulged or deformed by too close a piercing process.

The following pair of rules[4], in the ORO form, have objectives of reducing stamped product cost.

Sample Rule:

OPERATION: Blanking of parts.

RULE:

rule: Maximize the utilization of material when the parts are laid out on standard stock strips.

test: A_p should approach that of A_s

where A_p - is the surface area of the stamped part
 A_s - is the surface area of the stock strip allotted per part.

prescription: Alter the contour of the part to increase the number of interlocking features of the part with adjacent parts.

OBJECTIVE: To decrease the cost of the stamped part by utilizing as much of the material on the standard stock strip.

This rule is illustrated in Figure 6.

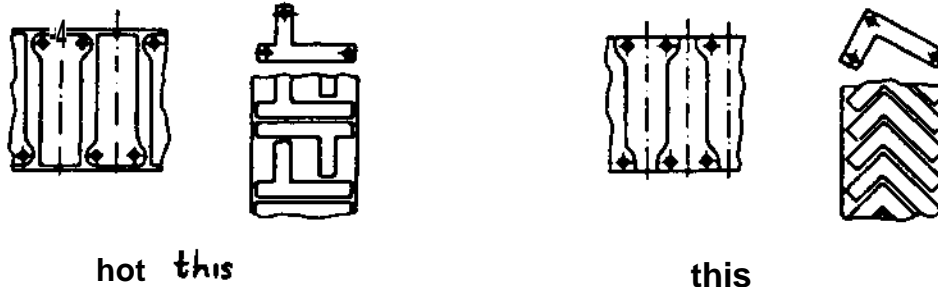

Figure 6

Sample Rule:

OPERATION: Blanking of parts.

RULE:

rule: Design the part with simple cuts, angular corners are preferred over curves,
prescription: Replace curved corners and cuts with angular corners or straight edges.

OBJECTIVE: To decrease the cost of the stamped part by utilizing standard straight edged blanking punches.

This rule is illustrated in Figure 7.



Figure 7

The current set of rules collected[5] is contained in Appendix C. These are the rules that will be contained in the knowledge-based expert system.

Additional Diagrams of Design Rules for Stamping

Sample Rule 3

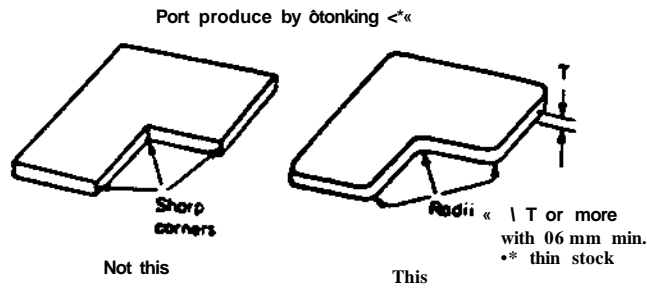

Figure 8

This rule states that the radii of corners must be at least one half sheet thickness.

Sample Rule 4

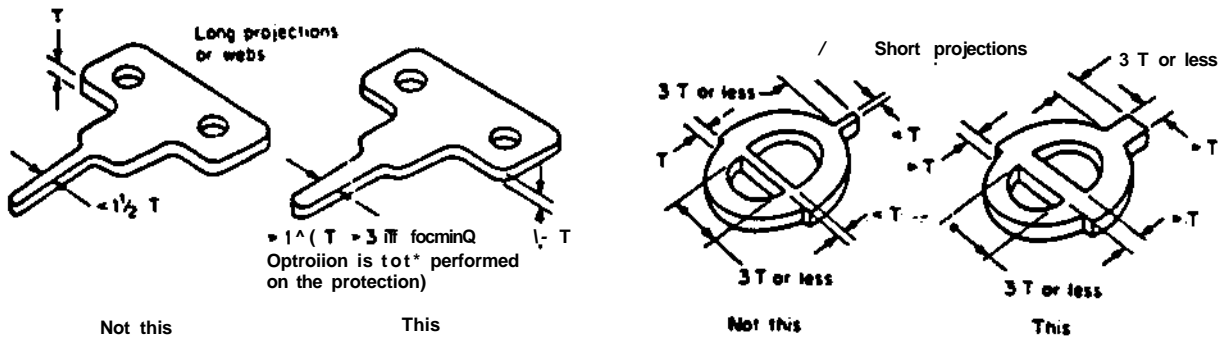

Figure 9

This rule states that the minimum widths of fingers and webs must be greater than a given factor times sheet thickness.

Sample Rule 5

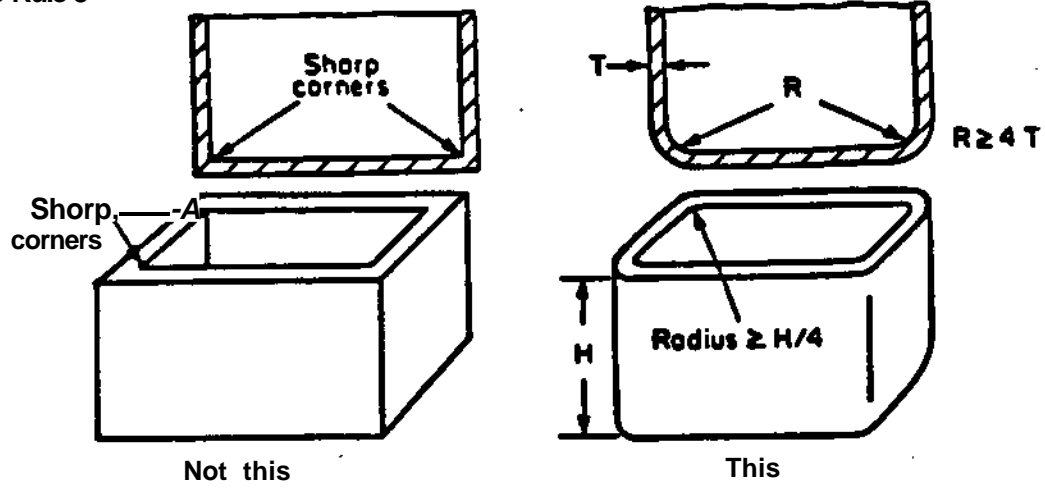

Figure 10

This rule states that sharp corners should be avoided and the bend radii should be a function of sheet thickness.

Appendix C: Typical Stamping Design Rules

Blanking Operation

- A. Blank size must be kept to a minimum.
- B. Minimum width of fingers or slots $> 2t$, where t = sheet thickness.
- C. Blank contour must be simple.
- D. Blanks should be designed with straight contour lines instead of curved contour lines.
- E. Triangular shaped canals with 60 deg. angles are preferred to the parallel-sided canals, with the slot's apex well-rounded.
- F. Sharp 90 deg. corners are to be avoided.
- G. Slots and canals which are to be trimmed later should be located in such a way that cutting will be unimpeded and will have the shortest possible line of cut.
- H. The most economical layout of the blanks on the strip is obtained when there is the greatest number of blank contours on a given surface of stock.

Indexing Operation

- A. Indexing hole sizes as large as permissible.
- B. Choose indexing pins whenever possible over gripping pads.
- C. If the two legs of a U-bend are not of the same width and length, an extra pilot hole should be placed to ensure accurate location of the bend.

Bending/Forming Operation

- A. Keep the burr side on the inside of a bend.
- B. Avoid "busy" areas in the stamping.
- C. Bend should be at right angles to the grain lamination of the sheet.
- D. Rounding radius of bends:
 - 1. Soft metals: $r = 0.3t$ to $0.7t$
 - 2. Hard metals: $r = 0.6$ to $1.2t$
 - 3. Very hard metals: $r = 2.0$ to $3.0t$
- E. Contour line of blank should form a 90 deg. angle with bending line.
- F. Minimum height h of legs, webs or flanges must be:
 - 1. Thin sheets: $h > 0.1$ in.
 - 2. Thick sheets: $h > 0.125$ in.
- G. Stampings with several bends or with irregular shapes should be nested with dowel pins which engage holes previously punched in the flat blank.
- H. Locate the bend line well outside of the edge of the contour line of the larger part of the blank.
- I. When flanges are bent upon a portion of the workpiece, relief holes must be punched at the points subject to high stress.
- J. Tapered flaps are preferred over the square shaped flaps.
- K. The number of formed portions on a component should be as small as possible.
- L. When a choice is possible, always choose the largest permissible bending angle.

- M. It is less expensive to make components in sections rather than to produce them as a single piece, since joining one or more stampings by welding or riveting is simpler than the complex tooling necessary for the one-piece job.
- N. Avoid complex bent parts split and join where possible.
- O. Avoid sloping edges and tapers in the region of the bend.

Piercing Operation

- A. Holes must be identical in shape and size for a given stamping die.
- B. Size and shape must be standard and available on the market.
- C. Round holes preferred over oval, square, etc.
- D. Minimum holes size:
Diameter of hole \gg Thickness of sheet
- E. Edge of punched hole should be at least $2t$.
- F. There must be at least as much material around a hole as the radius of the hole itself.
- G. Hole placement must be in areas of the workpiece that remain flat after bending.
- H. Holes should not be located too near the bending zone.
- I. If for some important functional reason the punched hole must be near the bending line, then the hole must be punched after bending.
- J. Holes must cross the bend line when it is not possible to provide the minimum gap between bend line and hole edge.
- K. Avoid waste by careful layout of cut-out parts on the strip.