

NOTICE WARNING CONCERNING COPYRIGHT RESTRICTIONS:
The copyright law of the United States (title 17, U.S. Code) governs the making of photocopies or other reproductions of copyrighted material. Any copying of this document without permission of its author may be prohibited by law.

Precision Flexible Machining Cells within a Manufacturing System

Mark R. Cutkosky, Paul S. Fussell, and Robert Milligan, Jr.
Carnegie-Mellon University and the Robotics Institute
Pittsburgh, Pennsylvania 15213

March 1983

Abstract

This report discusses the conceptual design of a manufacturing cell for a small-batch manufacturer. The cell produces precision parts with a minimum of machining equipment. The cell design emphasizes near-term technology and uses off the shelf items where possible. The proposed cell can run unattended for a moderate period of time (eg. over-night). The design philosophy is to treat the cell components and control programs as discrete modules in a hierarchy. The resulting cell is easily integrated into a larger system. It is also readily modified or expanded as more sophisticated equipment and techniques become available.

Copyright © 1983 Mark R. Cutkosky, Paul S. Fussell, and Robert Milligan, Jr.

This research has been funded by the Economic Development Committee of the Allegheny Conference on Community Development, the Robotics Institute, and Carnegie-Mellon University. This report is adapted from a document produced for the Economic Development Committee in October, 1982.

Table of Contents

1. Introduction	1
2. Design and Implementation Philosophy	3
3. The Machining Cell	4
3.1. Cell Capability	7
3.2. Autonomy	12
3.3. Cell Components	13
3.4. Cell Operation	19
3.4.1. Steady State	21
3.4.2. Between Part Runs	27
3.5. Skills needed to Develop and Maintain the Cell	30
3.6. Problems	31
3.6.1. Design problems	31
3.6.2. Runtime problems	32
3.7. Alternatives for the Future	33
4. Cell Integration into a Manufacturing System	34
4.1. System Definition	35
4.2. System Capability	35
4.3. Modifications at the Cell Level	36
4.4. System Components	36
5. Summary	40
6. Acknowledgements	40

List of Figures

Figure 1-1:	The Manufacturing System with Component Cells	2
Figure 2-1:	Hierarchical System Design	5
Figure 2-2:	The Machining Cell Communication Topology	6
Figure 3-1:	Typical Finished Part Made From Bar-Stock	8
Figure 3-2:	Machining Cell Layout -- First Arrangement	9
Figure 3-3:	First Variation on Machining Cell Layout -- Second Arrangement	10
Figure 3-4:	Second Variation on Machining Cell Layout -- Third Arrangement	10
Figure 3-5:	Cell Host-Controller Communication Scheme	11
Figure 4-1:	A Schematic of the Manufacturing System and the Factory Support Environment	37

1. Introduction

Manufacturing cells have been promoted by a number of researchers [Bjorke 79, Bourne 82a, Merchant 80, Wright 82a, Wright 82b]. A manufacturing cell is a group of machine tools and associated materials handling equipment that is managed by a supervisory computer. The cells are independent units but may be tied together as shown in Figure 1-1 to form a flexible manufacturing system. Several systems of this kind are currently being built in the United States and overseas [Gunn 82, Houston 81a, Krouse 81]. A number of difficulties, however, are hindering the construction of flexible machining cells that produce *precision* parts. In particular: The positional accuracy of industrial robots is poorer than the accuracy required for precision parts loading; the controllers for existing machine tools and robots are not designed to be supervised by a central computer; the techniques used to automatically monitor and control machining activities are not developed to the point where a cell can be trusted to run without human supervision; and the software for coordinating activities and machines within the cell is still largely a subject of research.

In spite of these problems, the design for a flexible cell producing precision parts becomes feasible if we are willing to do some development and to accept a cell that initially will depend on human supervision. In particular, the following solutions are needed for the difficulties cited above:

- Grippers and precision fixtures will have to be carefully designed to achieve accurate part set-up with relatively inaccurate robots. Given the state of the art, robotic applications generally require the design and construction of special grippers and fixtures.
- Sensors will be required to provide data about the status of the cell. The sensors will vary from air gap devices in the fixtures, to limit switches and load cells on the grippers, to a vision system which locates incoming parts and verifies the integrity of machined parts.
- Machine tool controllers will have to be modified so they can become components of the cell managed by a single computer controlling the cell, the cell host. The cell host will need to schedule the actions of the machine tools and it will gather information from the tools (including robots). The first modification to the controllers will give the cell host a straightforward way of communicating with them. Software will also be developed to manage the cell; both short term scheduling and longer term maintenance can be managed by the cell host computer.

Although the tasks listed above show that a considerable amount of development is needed to complete a precision machining cell it is possible to create the cell in a evolutionary way. Intermediate experience can be applied to the developing cell as it progresses from the initial implementation to a more advanced form. To make the evolutionary approach successful, the initial design includes the long-term goals of flexibility and autonomy. In keeping with this philosophy, we structure the cell control as a hierarchy. The cell host computer is responsible for activities like parts flow and machine coordination. The machine controllers act as interfaces between the cell host and the machining or handling processes and they control the individual machines. Sensors provide information to the machine tools and to the cell host computer.

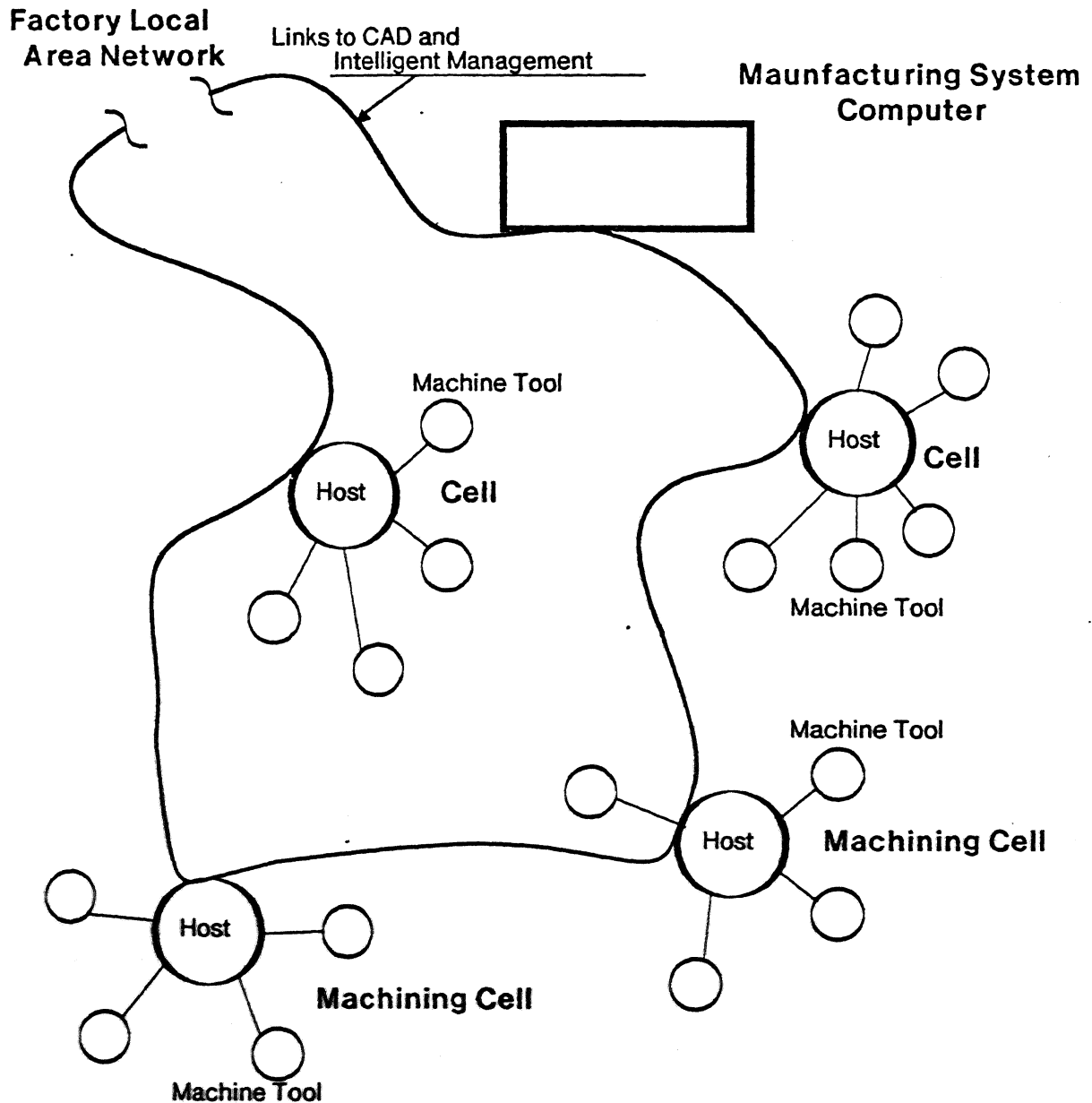

Figure 1-1: The Manufacturing System with Component Cells

The evolutionary development is also eased if the cell host can view the machine tools as input/output modules (where the input and output are parts). The idiosyncrasies of each machine are hidden from the cell host so that all the host sees is the module. In this way, new machines can be easily added and the old machines can be modified with little concern about side effects in the cell host computer. On a grander scale, as the cells are integrated into a flexible manufacturing system the system level computer is able to view the

cells as input/output modules and will not need to concern itself with the detailed operation of each cell.¹

The design which meets these requirements provides a systematic framework in which a functioning precision cell can be built and then integrated into a larger manufacturing system. The design uses equipment which for the most part is available in today's marketplace. The robotic manipulators, the machine tools and the sensors are all available in rudimentary form. What is not available can be developed along trends visible today. Thus, during the early stages of the installed cell it may be necessary to have a human operator oversee the machining operations and ensure, for example, that a tool breakage has not occurred. The cell could function in this way until an automatic system for monitoring such problems was developed. Then the cell could approach operation independent of the human operator.

2. Design and Implementation Philosophy

The heart of the design is flexibility. Our intent is to develop a cell that will produce a variety of product forms and fit in a manufacturing system with other cells. The cell that will satisfy these needs is complex. To make the implementation of the design tractable, the design philosophy is founded on two principles:

1. the cell and its component parts and pieces must be modular, and
- 1 the cell and its components fit in a structured hierarchy.

The former idea is simply justified. The modular parts, whether they are grippers, fixtures, lathes, or software communication drivers, can be individually designed if care is given to the specification which defines how the modules fit together. If a module is designed strictly as something that can operate on an input and produce an output, then the input-output characteristics *define* the module. If the modules are built to these specifications, then the integration of the modules into the whole is simplified, the whole is easy to understand, and debugging the system is simplified. By the same token, eventual modification of the cell is made easier.

The second principle provides the design with several nice features. The cell can be viewed from any of the levels of the hierarchy. If the viewer is interested in the input-output characteristics of the cell, that information is readily available from the hierarchy. But, if the viewer wishes to inspect features of the cell much lower in the hierarchy, such as individual protocols between controllers and the supervisor, the information is equally available, just at a different, *but well defined*, place. One compelling feature of the combination of these principles is the ease with which one can change lower elements of the hierarchy

¹The concept seems straightforward but we have found it surprisingly easy to make components to a particular controller or process that prevent it from becoming an independent module.

without adversely affecting the higher elements. The only requirement is that the low-order modification not change the function (or input-output characteristic) of the module.

Figure 2-1 is a conceptual picture of the hierarchy. The machine tools (robot, mill, lathe, etc) are individually controlled by stand-alone computers. These computers control the machines in real time and act as an interface to the cell host. They hold responsibility over the individual machines, but also respond to higher level commands from the cell host computer. The cell host is a larger computer system responsible for the scheduling of operations within the cell. But this computer, too, must act as an interface between the machining cell and the computers at the manufacturing system level. The cell host must be able to satisfy requests from the higher level computers for data on the cell status.

The design described in this report is for a near-term cell; it cannot use components that will require more than a couple of years before they are ready for industrial use. This restriction forces us to make a number of compromises:

- The design is restricted to existing computer technology for the supervisor. There are also practical restrictions on how the computers within the cell are networked together. A star topology, with the supervisor at the center, is most likely due to the limitations of the machine controllers (see figure 2-2).
- The design is restricted to existing robots and material handling devices. Robot technology is rapidly advancing, but by using today's equipment we benefit from designs that have been tested in the marketplace (*see* section 33).
- The sensors used throughout the cell will be simple. They will be used, for example, to detect the presence of parts and to signal conditions such as dropped parts. By using readily available microswitches, linear variable differential transformers, optical sensors, and the like, we seriously limit the sophistication with which the cell can detect errors, but we are assured of reliable devices with simple interfacing requirements.
- Existing controllers will either be modified or enhanced by strap-on microcomputers [Houston 81a].
- Grippers and fixturing will be designed using conventional technology, and built from off-the-shelf components.

3. The Machining Cell

In this section we examine the components, the characteristics and the operations of a precision flexible machining cell. In the jargon, a machining cell is generally assumed to include several numerically controlled machine tools* and materials handling equipment for transporting parts, a level of inter-machine communication and some supervisory control at the cell level. Manufacturing cells for the so called "factory

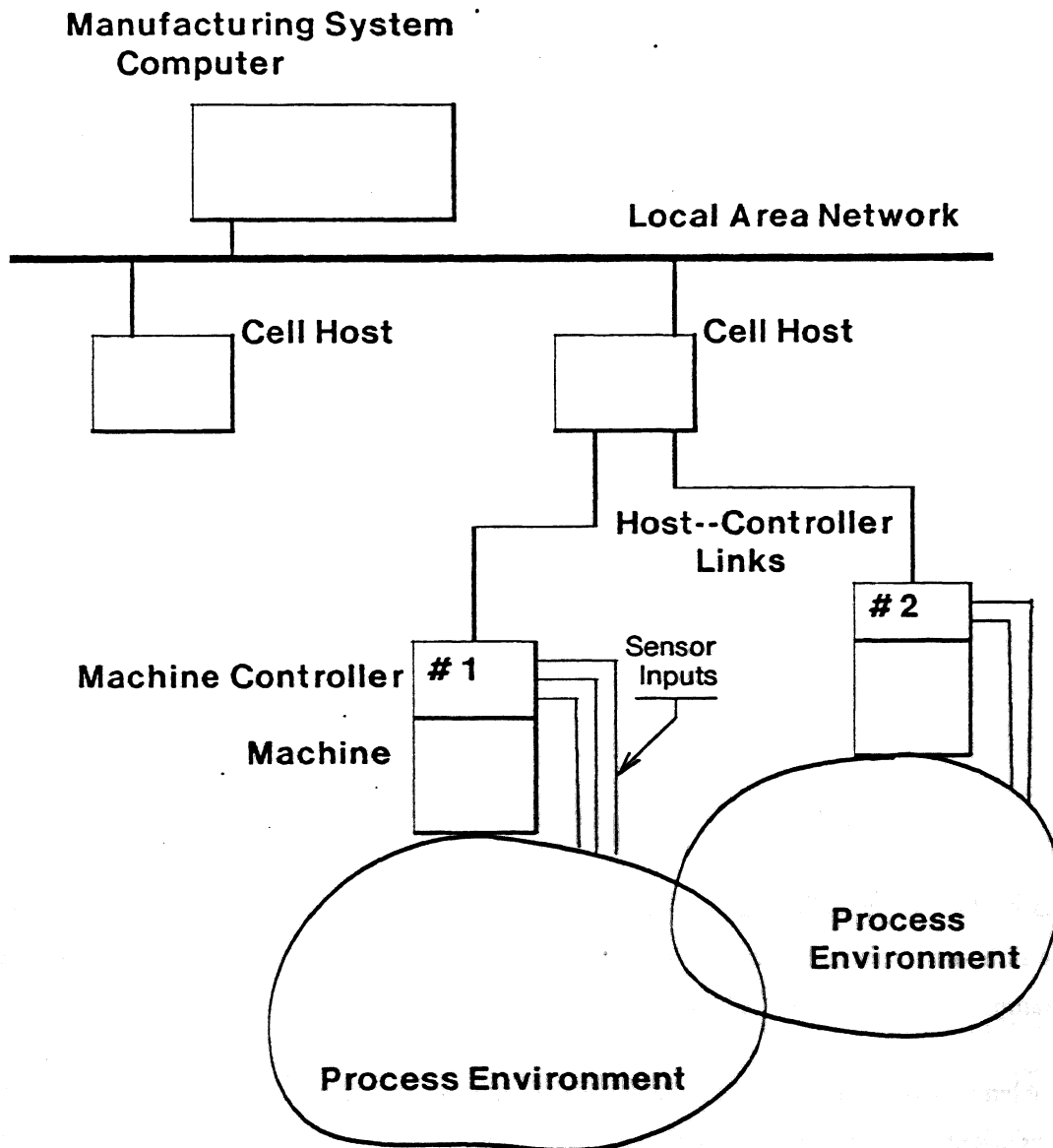

Figure 2-1: Hierarchical System Design

of the future" are understood to be autonomous entities although the present state of the art precludes full autonomy.

The results of this section will be a set of guidelines for building a flexible machining cell. At various stages during the design process one is confronted with several options, any of which may be the best choice under certain circumstances. Therefore, instead of specifying a single cell design we describe the components of a cell and present several examples of how these components may be put together. We then discuss the operation of a machining cell, pointing out the differences caused by choosing one arrangement or another.

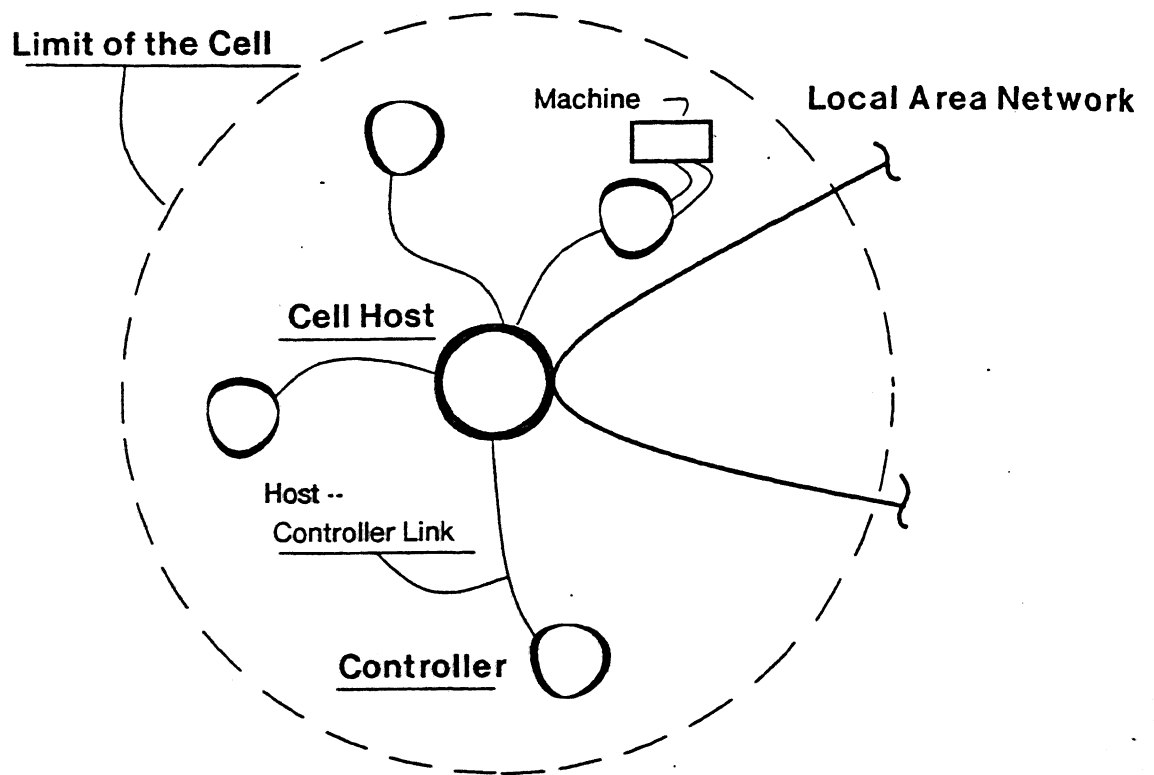

Figure 2-2: The Machining Cell Communication Topology

In section 3.5 we look at the skills required to develop a machining cell and the skills needed to keep it running. These skills are nearly independent of the final cell arrangement and the discussion of them applies to any of the examples given in sections 3.3 and 3.4.

Common problems encountered during the development of a cell, and problems to be expected during cell operation, are discussed in section 3.6 along with a few remedies.

Finally, in section 3.7 we consider some alternatives that, while they are not practical for a near-term cell, look attractive for the future.

For common reference, some of the terms used frequently in this section are explained below:

- **cell host** -- The host is the small computer, or computer system, that acts as supervisor for the cell. It manages the cell operations and acts as the interface to the factory level computer system. Parts programs are down-loaded to the machines through the cell host.
- **cell supervisor** -- The cell supervisor is the high-level program that runs on the cell host.

- **machine controller** -- The controller is the computer that controls a particular machine. It also acts as the interface between the machine and the cell host. Machine, here, is used in a generic sense to mean any of the components that work in the cell including machine tools and robots.
- **machine tool** -- The term machine tool is used as it is in general industrial experience, i.e. a machine tool is a powered device that removes material from, or in some other way changes, the physical characteristics of a work piece. Typical examples are lathes, mills, grinders, and so on.
- **robot** -- In this cell, the robots are material handling devices with multiple degrees of freedom. They are equipped with specialized grippers for loading and unloading the machine tools.
- **fixturing** -- The specialized tooling for holding and locating parts at different locations within the cell. Grippers on the robots are included as a special example of fixturing since they must locate and hold parts, just as the fixtures on machine tools do.

3.1. Cell Capability

As it turns out, the range of different parts that a precision cell can produce is chiefly determined by the fixturing within the cell. Machine tools can machine pieces anywhere from an inch to over a foot on each side and computers are as flexible as the programs written for them; but a robot gripper or a set of clamps can only be expected to accommodate one or two basic families of parts without being changed. For the near term it is unrealistic to attempt to develop "universal" fixtures. This is particularly true for a *precision* cell where the close machining tolerances call, in turn, for precision fixtures. Thus, the fixturing in a machining cell establishes a "window" limiting the sizes and shapes of parts that the cell can produce without human intervention. A good example of a basic parts family that lies mostly within a single window would be: "precision parts made from metal bar stock up to 25 square inches in cross section." This basic family is used as an example for the rest of this section.

Figure 3-1 shows a typical finished part from the bar-stock family. It requires most of the operations that we would expect a small machining facility to perform (e.g., turning, drilling, reaming, tapping, boring, milling). Practically speaking, the minimum equipment for producing these pieces (whether the machining is done automatically or by hand) consists of a vertical axis mill and a lathe with a centering four jaw chuck. The CNC (Computer Numerical Control) versions of these two machines form the core of our small flexible machining cell. The CNC machines are serviced by materials handling equipment, including robots. Figures 3-2, 3-3, and 3-4 show plan views of three possible configurations for the core elements of the machining cell. The comparative advantages and disadvantages of these different arrangements will be discussed later in this section.

In our discussion of the cell we assume that parts will arrive presented to the cell in such a way that the robots can accurately pick them up. One possibility, shown in figures 3-3 and 3-4, is for parts to arrive on cart

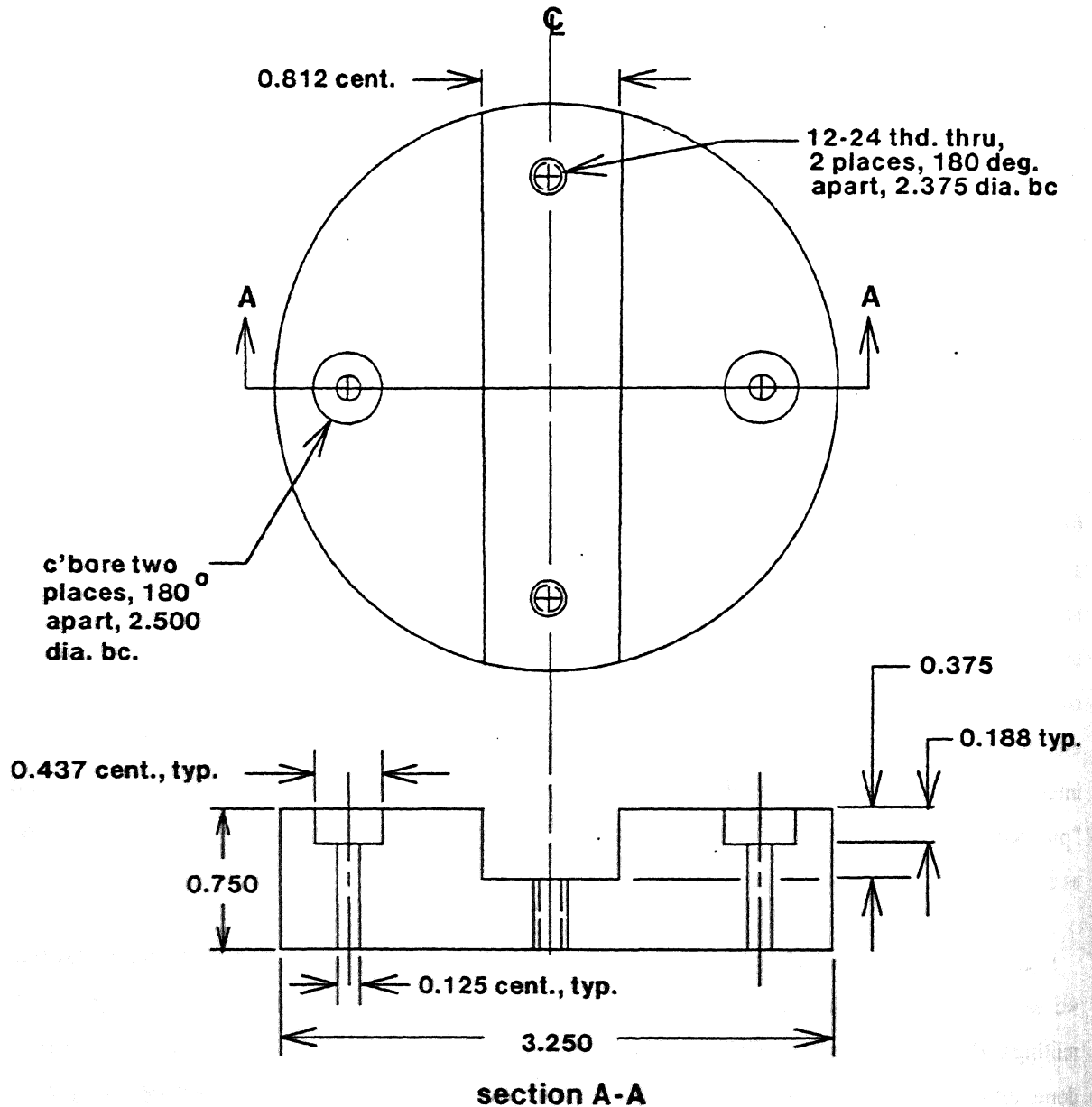

note: all dim.'s in inches, + / - 0.003

material: cold-rolled steel

Figure 3-1: Typical Finished Part Made From Bar-Stock

which may be manually controlled or self-guided. This solution lends itself to forming a flexible manufacturing system composed of several cells as suggested in section 4. The mechanics of acquiring and handling precision parts are treated in section 3.4.1. The physical input to the cell will include new cutting tools for the CNC machines as well as workpieces. Similarly, the output from the cell will include worn and broken tools. The cutting tools generally will not resemble members of the parts family that the cell is

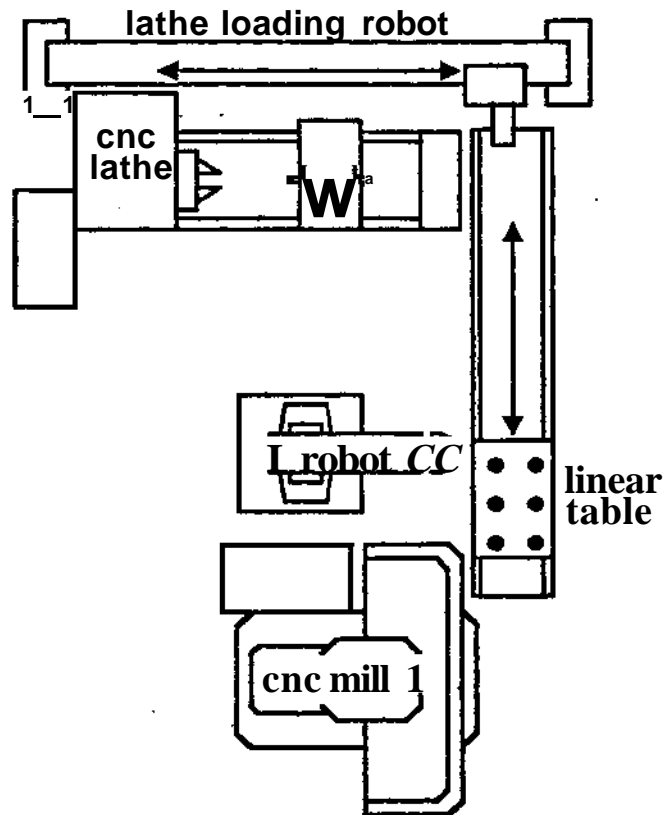

Figure 3-2: Machining Cell Layout - First Arrangement

designed to produce and they consequently pose some special handling problems which are discussed in section 3.42.

It should be pointed out that the cell is not restricted to producing parts that require all the machining operations mentioned above. The cell can perform any subset of the available machining operations. Operating the cell with only some of machines is inefficient, but there are times when it is useful. For example, if the lathe is temporarily out of commission the cell can produce pieces that require only milling. The cell control system (see *a host computer section 33*) should allow this sort of flexibility.

Figure 3-5 shows the machining cell from a different perspective. It is applicable to any of the three physical arrangements shown earlier and provides a schematic of the cell control and communications channels. The cell host computer is the heart of this schematic and the capabilities of the cell from the standpoint of control and communications depend almost entirely on the host. The host will be responsible for the interaction between all the components of the cell including the CNC machine tools, robots and vision

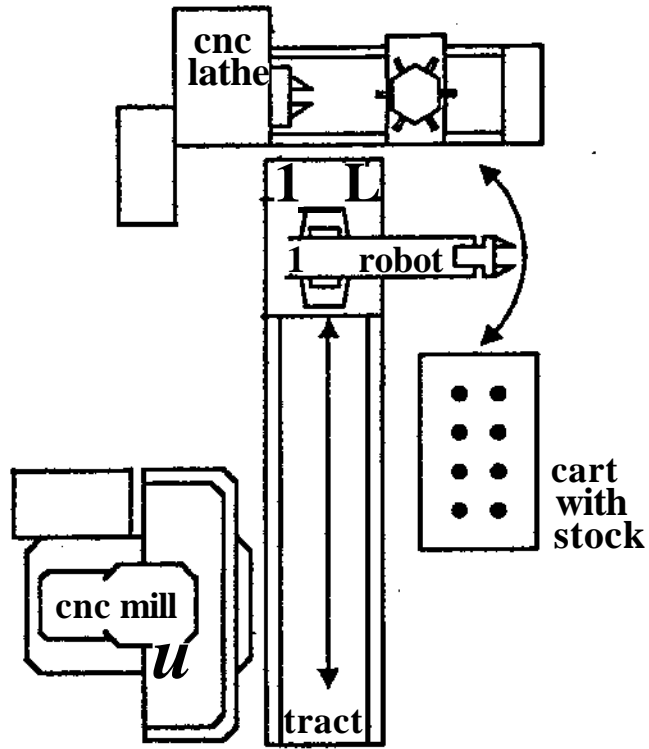

Figure 3-3: First Variation on Machining Cell Layout - Second Arrangement

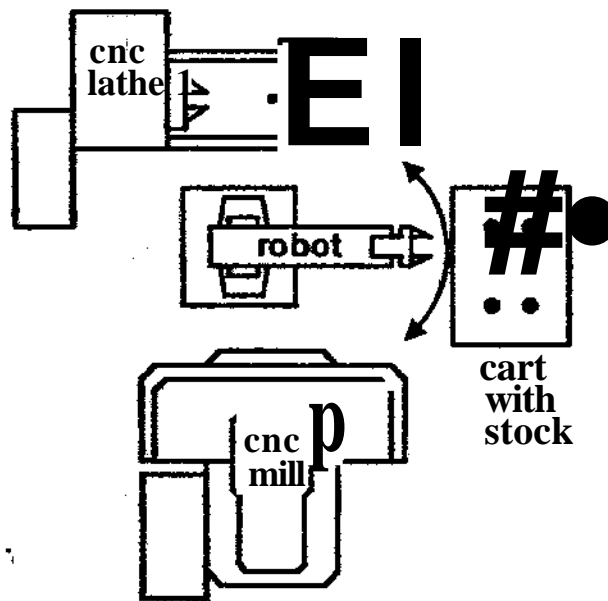

Figure 3-4: Second Variation on Machining Cell Layout - Third Arrangement

system. The coordination of the machine actions will be the most complex thing the host does. The host will also pass parts programs to the controllers. The parts programs themselves are stored elsewhere (see section 4.4).

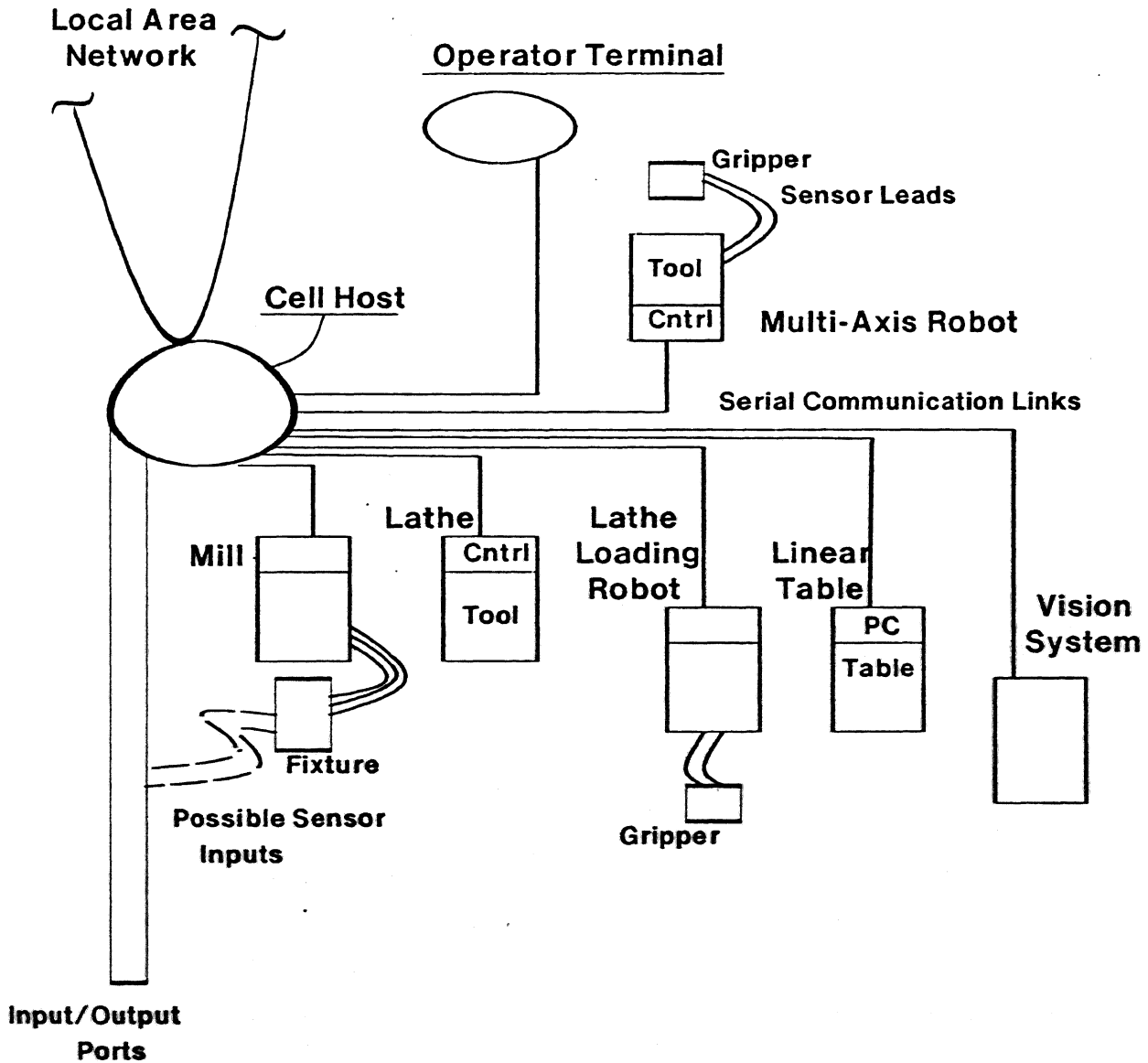

Figure 3-5: Cell Host-Controller Communication Scheme

The cell should be able to provide statistical information to any higher level computer. The kind of data the higher level computer should have access to includes the following:

- machine tool operation time

- the number of parts processed in the last time period (which should be a flexible number, e.g., batch, day, hour)
- the number of parts that came into the cell in the last time period
- the number of incoming parts that were acceptable
- the number of parts that were scrapped during the last time period
- how much the various cutting tools have been used
- what failures have occurred during processing
- details of the failures

3.2. Autonomy

The flexible manufacturing cell is intended to be partially autonomous and the effects of this decision appear throughout the design. The equipment that moves materials through the cell and the cell host that supervises cell activities are provided for reasons of autonomy. The economic analysis of a cell is also closely allied with its autonomous nature. The cost of the additional equipment and software to run the cell without people must balance the savings in reduced human intervention. This cost consideration probably restricts the initial construction of the cell to a development environment.

"Autonomous" implies more than automatic, though. The materials handling equipment and the cell host allow the cell to run automatically, but autonomous operation requires some additional features. In particular, the ability of a cell to function independently depends on its tolerance of errors. An autonomous cell must be able to recognize bad incoming parts, to recover from parts lost in process and to recover from common failures such as tool breakage and part mis-alignment. Unfortunately, such errors are very difficult to recognize and tolerate. This difficulty is the source of our decision to limit the cell to partially autonomous operation, meaning that human operators will check things out now and again. The tasks that people perform will be varied, but it is a goal of the design for this cell to reduce the time individuals spend at each task. This amounts to increasing the productivity of these people. It would be an achievement to operate a cell for three shifts with people attending it for only one of those shifts. This is a practical goal using today's technology and in fact a number of more specialized manufacturing operations have started in Japan which are attended by six people during the day shift and one person during each of two night shifts [Gunn 82].

An autonomous cell should also have some rudimentary inspection capabilities. In this design, we use automated visual inspection both for locating incoming parts and for final part inspection. The final part inspection is limited in the near-term cell. Complete, automated, gauging and inspection is not feasible for a

number of reasons. Automated visual inspection, while quite broad in its potential applications, is unable to measure dimensions such as the depth of a blind hole or the diameter of an internal snap-ring groove. This is true for any physical characteristic where a profile image is not available. Programmable measuring equipment that is not based on visual information is still extremely expensive, although the relative price of coordinate measuring machines is beginning to drop. Programmable coordinate measuring machines are more difficult to interface with the rest of the cell than are vision systems, and this is another factor that excludes them from a near-term cell.

The near term cell will be able to check for simple faults with a variety of sensors, including video cameras. It will respond to errors in machining or transporting parts by simply discarding the part in question and recording the fact that a part was scrapped. Once the cell is running smoothly, the number of errors should be small and the rejection rate is expected to be low.

3.3. Cell Components

In this section we describe the components that make up the machining cell. The primary manufacturing elements are shown in figures 3-2, 3-3 or 3-4. The other major components are conceptually shown in figure 3-5.

- ***CNC machine tools:***

- o A vertical axis CNC milling machine. This machine tool should be equipped with closed-loop control of the position of the table and the spindle to provide positional accuracy on the order of ± 0.0005 ". The spindle speed should be software controllable. The mill should be equipped with a tool changer that will hold a large number of tools to accommodate work pieces requiring many different milling operations and to allow the processing of a variety of work pieces without pausing to install different tools in the tool changer. The power of the spindle drive motor is not critical for parts made from bar stock, such as the parts family discussed in section 3J. Similarly the range of travel of the table and the spindle are not critical for these relatively small parts. Examples of a suitable machine tool include the Bridgeport BTC I and the Matsuura MC-500V vertical axis CNC milling machines.
- o A horizontal axis CNC turret lathe. Like the milling machine described above, this machine tool should be equipped with closed-loop position control on all axes (in this case the longitudinal stroke or z-axis displacement and the cross stroke or x-axis displacement of the turret). This control will, like the control for the milling machine, be required to hold positional accuracy within the range of ± 0.0005 ". The spindle speed should be software controllable. The number of tool positions available on the turret should be as large as possible to promote flexibility in machining complex and/or varied work pieces. Any less than, say, eight tool positions would significantly reduce this flexibility. It is unfortunately inherent in the design of a turret lathe that fewer tool positions are available on the turret than would be found on a typical tool changer for a milling machine. Neither the power of the spindle drive motor nor the range of travel of the turret in the x and z directions is

critical for the family of small work pieces under consideration. A typical example of a lathe of this type, size, and capability is the Miyano model CNC-6BC-3 turret lathe.

• *parts handling devices:*

- A lathe loading robot. The lathe loading robot is a specialized manipulator designed to be able to reach into a CNC turret lathe for loading and unloading parts from the chuck. The commercially available lathe loading robots are not particularly sophisticated machines. In general they consist of two arms suspended from a carriage riding in an overhead track, rather like an overhead crane. One arm is usually used for loading new pieces into the lathe and the other for unloading finished pieces. The arms are pneumatic or hydraulic and operate by means of limit switches. The grippers at the ends of the arms may be pneumatic or hydraulic. Only the movement of the carriage in its track is continuously programmable. This is accomplished by driving the track with DC servo motors and either ball screws or a rack and pinion. Examples of commercially available equipment are the Manca "Double Arm Gantry System" and the ISI lathe loading system. A more flexible (but more expensive) alternative to the specialized lathe-loading robot is to use a 5 or 6 axis robot, such as the one described below, for tending the lathe. Another possibility is to mount the mill-loading robot on a track running between the mill and the lathe. These possibilities are illustrated in figures 3-3 and 3-4 and discussed below and in section 3.4.1.

- A mill-loading robot. This small robot requires at least five programmable axes to pick up a part from a flat surface and to orient it on the bed of a milling machine. With six axes the robot can place parts into fixturing that is arbitrarily inclined with respect to the horizontal or vertical. The robot should be quite accurate since it will be used for *precision* loading of parts into fixtures on the mill. A number of accurate, 5 or 6 axis robots are available. They include the Cincinnati Milacron T³-726, the ASEA IRb-6, the CRYO 820 and the Bendix AA-160. The quoted repeatabilities of these machines are all within ± 0.008 inch. These robots are not large, but they will reach at least 30 inches and they will all handle at least 13 lb. Thirty inches should be enough to reach both the center of the linear table and the bed on the milling machine shown in figure 3-2. A 13 lb. limit for the robot arm effectively limits workpieces to 10 lb. once a gripper is mounted. This is a bit restrictive for pieces that are not made from aluminum although we note that pieces can enter the *cell* weighing more than 10 lb. if they first go to the lathe and weigh 10 lb. or less after turning. If 10lb. seems too restrictive, then one of the larger robots in this group such as the CRYO 820 or the Bendix AA-160 should be picked. If the robot is to be used for loading the lathe in addition to the mill (as suggested in figures 3-3 and 3-4) it will probably require a reach of more than 30 inches. This is particularly true for figure 3-4 where the reach of the robot determines how far apart the machines can be placed. If the larger robots in the group above do not have enough reach then it will be necessary to use a robot such as the Cincinnati Milacron T³-746 or the ASEA IRb-60. For a precision cell, it is not desirable to pick a larger robot than necessary since the increased reach and payload come at the expense of accuracy. Another consideration is that CNC lathes generally offer less clearance for loading and unloading than CNC mills do; this may rule out any robot with a bulky arm.² Figure 3-3 shows a very flexible arrangement in which the robot is mounted on a track to improve its reach. Some robots, however, have stringent mounting requirements and would not perform well on a track.

²Some robots, such as the Bendix AA-160, can be mounted hanging upside-down from the ceiling which would improve access to the lathe.

Robot controllers are much the same as machine tool controllers and the integration problems with both are explained below under *controllers*. Some robots are much easier to program than others. The better ones provide coordinate transformation packages, tool or "hand" coordinates, and easily specified inputs and outputs for working the gripper. This is a distinct advantage but the state of the art in robot software is changing so rapidly that if a particular robot does not provide such amenities today, it may offer them in a few months.

- ***linear table***

In figure 3-2 a linear table is used to transfer parts between the lathe loading robot and the mill loading robot. In addition, the table may stop beneath the camera of a vision system. The table carries a pallet with some simple fixtures to locate parts so that the robots can pick them up easily. The pallet should be big enough to hold several parts and will therefore offer a bit of in-process storage. The linear table must be quite accurate, but it need have only a few fixed stops. Linear transport tables are made by a number of manufacturers including SI Handling Systems.

- ***controllers***

Controllers for machines and parts handling equipment -- The controllers available in today's market provide good support for the operation of the individual machine tool. Our requirement, however, is to place a controller in an autonomous machining cell. This has two important consequences:

1. the controller must be able to send and receive complex messages from the cell host, and
2. the controller must allow the cell host to manage the tools' actions.

In particular, the controller must allow the cell host to do the following:

- Command the execution of programs and/or subprograms on the machine controller.
- Down-load parts programs to the machine controllers and receive up-loaded programs from the machine controller.
- Access the state of the machine controller. The access will consist of a message containing relevant information about the machine and its controller (including the robots). This is essential for the cell host to maintain a detailed account of the status of the cell.

There are additional functions the supervisor might want, but the list above already represents functions that no existing controller provides in a reasonable form. Most existing controllers do provide communications channels (generally some combination of parallel I/O ports and serial data lines) but few will allow a cell host to command the running or stopping of a controller program. Program up-load and down-load is provided on the more advanced controllers but it requires operator intervention. This is unacceptable for an autonomous cell. Solutions to this dilemma come in a couple of flavours, but basically involve either putting a small computer between the controller and the supervisor [Houston 81a, Houston 81b] or re-writing the controller software [Syiek 82]. Presumably, the people who make machine tool controllers will begin to build controllers capable of supporting the functions above, but the industry is conservative. Such controllers *may* be available in two years. The near-term controller that meets the requirements above will probably have a single serial line to interface to the cell host.

- ***a vision system***

Automated visual inspection will be used both to locate incoming parts and to perform final part inspection. A number of manufacturers produce what are essentially stand alone microprocessors combined with a great deal of special purpose hardware and software, all designed to process images from one or more video cameras. By process images we mean, roughly, the following: acquire an image (what amounts to a "snap-shot" of a particular field of view at a particular instant), convert the image to digital form, and perform a variety of computational tasks on this digital information. The computational tasks range from simply recognizing a distinct object to calculating its position and orientation within the field of view of the camera. Some of the more important differences between various vision systems are:

- Vision systems, like machine controllers, are based upon a microprocessor. It follows that the more advanced the microprocessor used in a particular system, the more desirable the system. Along these lines, a vision system utilizing a microprocessor with a 16 bit architecture is preferable to one using a microprocessor with an 8 bit architecture.
- Just as machine controllers must support two-directional communication with the cell host, so must vision systems. Furthermore, the need to allow the cell host to control the system's actions is much the same for a vision system as for a machine controller. Both of these characteristics are absent in some of the currently available commercial systems.
- All commercially available vision systems process pictures either as binary or as grey-scale images. Here the term binary implies that all images are seen as combinations of pure white and pure black dots or pixels. Grey-scale, on the other hand, implies that images are seen as combinations not only of pure white and pure black pixels, but also of pixels having intermediate, or grey, levels of light intensity associated with them. A vision system which provides grey-scale capabilities is more desirable than a binary system if the intended application for the system can benefit from the additional information provided by grey-scale information. Similarly, if grey-scale processing is desirable for the application at hand, the resolution with which levels of light intensity can be distinguished by the system becomes important. Thus a system capable of distinguishing, say, 16 distinct levels of light intensity would be more desirable than a system which distinguishes only 8 grey-scale values. The software required to make use of this grey-scale information is often not commercially available and may have to be developed for specific applications. (see *Software* below).
- Another, frequently used criterion for comparing vision systems is the number and arrangement of pixels present in the imaging element of the video camera. Simply put, the more pixels there are in the imaging element, the more information will be available from each picture taken. In other words, the system is able to distinguish finer details in the image. The arrangement of the pixels is typically in the form of an (approximately) square matrix. For certain applications, however, the arrangement of the pixels may vary, such as in the case of linear array cameras intended to acquire information from a single axis (i.e. a one-dimensional image rather than a two-dimensional image). Common rectangular imaging elements range from 128 X 128 pixels (rows X columns) to approximately 256 X 256 pixels, while a typical linear array may consist of a single row of 4096 or more pixels.
- Software. This is probably more important than all of the characteristics of a vision system described above. The software provided with a particular vision system will control, to varying degrees, the speed, accuracy, and overall utility of the system. Here software refers to everything from the lowest level image acquisition and processing routines to the highest

level user interface. During the latter half of the 1970's a set of algorithms for binary image processing was developed at Stanford Research Institute (SRI) [Agin 82]. Since these algorithms are efficient and in the public domain, virtually all commercially available vision systems utilize them for the very low level tasks of image processing. The most significant differences in the software provided with various vision systems are therefore found in the higher level sections of code, particularly the user interface. At one end of the spectrum, the user interface may be a fairly simple, user friendly, menu-driven routine which prompts the user for a command which in turn causes a particular action to be taken. Towards the other end of the spectrum the user interface is far more flexible, but less user friendly. The interface is an interpreter with a syntax reminiscent of a Pascal which enables the user to define, store, and execute complex functions.

An example of a typical vision system, featuring a 16-bit microprocessor, 16 distinct grey-scale levels, the ability to handle images of 244 X 248 pixels, and an advanced high-level programming language (RAIL) implemented as an interpreter, is the Automatix AutoVision IL. This system might typically be combined with a General Electric model TN2500 CID solid state video camera having 244 X 248 pixels sized 0.0014" X 0.0018".

- ***clamps and fixtures***

Clamps and fixtures play an especially important role in a near-term flexible machining cell. This is because they are expected to locate and align parts in addition to holding them while they are machined or transported. These fixtures and clamps fall somewhere between the hard automation fixturing used for high volume production and the versatile clamps and tooling used in job shops. Like the fixturing in hard automation, they are designed to facilitate automatic loading, locating, and clamping of parts. At the same time, they must show some of the versatility of job shop tooling so that they can accommodate any of the pieces that the cell might produce. It is not possible to buy ready-made fixturing that fits this description. Instead, the fixturing will have to be built from a combination of components, some intended for automated production and others designed for manual production. The grippers used on robots constitute a special type of fixturing, less rigid than the clamps on machine tools but lighter and more versatile. Both the machine tool fixtures and the robot grippers will be provided with simple sensors, such as microswitches, to indicate whether workpieces have been properly located against them (*see sensors*). The robots can also be given Remote Center Compliance devices to reduce the contact forces occurring between parts and fixtures. These passive compliant units are manufactured by ASTEK INC. and Lord Corporation. They were actually designed to aid robotic parts assembly, but the act of sliding a part into a precision fixture is much like an assembly problem. The mechanics of accurately loading parts into machine tool fixtures are discussed in more detail under section 3.4.

The ability to establish and maintain close tolerances on parts from one process to another depends entirely on the accuracy and repeatability of the fixturing in this cell. A more advanced cell, provided with force, pressure and slip sensors and advanced vision and gauging equipment, would be far less dependent on fixturing. Some of these more advanced sensors are discussed in section 3.7.

- ***host computer***

A number of manufacturers make computers which are suited to cell supervision. A 16 or 32 bit internal architecture is sufficient, with the 32 bit models probably being more appropriate. A computer system built around the Motorola MC68000 series of computers or one of the small Digital Equipment Corporation Vax, say a Vax 11/730, would be excellent. With any particular choice though, the designer must keep several factors in mind:

- Considerable software development will be required to implement this cell. The correct choice of operating system, source language, and support environment can *greatly* influence the efficacy of the development effort [Anderson 82]. The system will need the power and speed to service communication with all the machine controllers and must provide serious support to programmers building system programs. In particular:
 - the cell supervisor scheme will need to be built largely from scratch. This program will be a major system level program.
 - Software will need to be written to talk to the machine controllers. There are many excellent designs for communication protocols between computers, and the operating system should support their implementation.

The UNIX³ operating system is an excellent program development operating system, and it provides good services to system programmers. It is a time-sharing system, though, so the machine tool communications system must be designed very carefully.

- The cell host computer will initially be a stand-alone computer. It will only need to communicate to the machine controllers below it in the hierarchy. Later development may place the computer within a factory-wide network.
 - The operating system should support an available network system. Alternatives abound, from Digital Equipment Corporation's DECnet (phase III), to the proposed multi-company ether-net standard [Shoch 82], to many others.
 - The initial cell host, as a stand-alone computer, will need all the support equipment that a full fledged system requires, for example, disks and tape drives. Later, as a part of the factory, it may only need the processor and main memory. The latter configuration assumes that a factory level computer can down-load operating systems and applications programs. This particular decision has implications for the topology of the factory-wide computer system and should therefore be deferred for the time being.

- **sensors**

Any automated manufacturing cell depends on sensors. To a large extent, the quantity and the sophistication of the sensors in a cell determine its ability to function autonomously. The cell treated in this document is only semi-autonomous and therefore requires fairly simple sensors. These will be of several types:

- Optical sensors about the linear table to signal its location, and indicate the presence of parts on it. These optical sensors can be photodiodes and will work in much the same fashion as mechanical limit switches. They are distinct from the vision system, which will also be sensing the location of parts on the linear table, but which is a much more powerful and complex device and is treated separately.
- Microswitches mounted on machine tool fixtures and robot grippers. Some of the microswitches will indicate whether a gripper or clamp is open or closed. The machine

³UNIX is a trademark of Bell Labs

controllers need signals confirming that the commands to open or close clamps and grippers have been successful. Otherwise, a robot might try to load a part into a clamp that never opened due to some equipment malfunction. Other microswitches will be mounted where they give a signal only if a part is correctly located within a gripper or a fixture. For example, if parts are supposed to rest snugly against the back plate of a gripper then a group of microswitches mounted at the back plate will all be depressed only if the part is in place. A particular arrangement of switches can only be expected to work for parts within a single family, which means that when the fixturing is modified the switches must also be rearranged.

- Pneumatic sensors can be incorporated into grippers and fixtures. The rate of air flow from these sensors, or the back pressure felt by these sensors, indicates whether the clamping surfaces are firmly contacting the face of a workpiece. Ideally, the air emanating from these sensors should also help to keep the contact areas free from chips and dirt.
- Finally there will be a number of sensors detecting things like air pressure, oil pressure, and motor temperature for the machines in the cell. These are wired to signal the machine controllers when something goes out of the normal operating range, but the cell host should have access (through the controller) to them as well.
- Many other sensors are also available. For example, strain gages could be used to measure the clamping force of a fixture, piezoelectric accelerometers could measure the vibration during machining, and linear diode array cameras could measure the length and width of pieces. A compact optical array could also be used to detect the edge of a part in a fixture, and to indicate how far the part was loaded into the fixture. All of these devices require developing control algorithms to make use of the information they produce. They also cannot improve the fundamental accuracy of the cell until more advanced robots, grippers and fixtures become available to work with them. For these reasons, we omit them from our near term cell.

Where examples of specific pieces of equipment have been given in the list above they reflect preferred choices. For instance, the 6 axis robots listed above all have coordinate conversion software and have a facility for down-loading and up-loading programs. If a robot is chosen that lacks these amenities then a considerable amount of development time will be spent in writing extra software.

3.4. Cell Operation

The discussion of how the cell operates is divided into two distinct categories of cell-level tasks: steady state operations and periodic operations. Error handling is treated separately in section 3.6.2.

The cell operates in a steady state during a parts run. The parts move through the cell under the guidance of the cell host. Each machine tool and robot runs a CNC parts program or movement program at the command of the cell host. During the parts run the cell host needs little or no correspondence with any factory level management for decisions regarding cell operation. Management data concerning cell status is, as always, available from the cell host.

The temptation to only view the cell as a sequence of part movements and individual operations is strong, but such a view is incomplete. At any time, the cell is working on a variety of parts, each at a different point in the process. To realize the full potential of the cell the actions must occur asynchronously. The cell host must be able to manage the actions of the mill, lathe, robots, and vision system so they function in parallel. This turns out to be a difficult problem, for many of the differing actions are related. Managing a cell so that the machines can function in parallel is a topic of current investigation. One technique for coordinating the different activities is to use a rule based production system [Bourne 82a]. The machine inter-relations within the cell are delineated in the set of rules and their parallel execution is managed by the production system. The production system is somewhat computationally expensive, though. It would also require considerable development work to implement. Other schemes may prove to be appropriate for managing the parallel operations within the cell, but most of the currently available systems are difficult to change and do not clearly describe how the cell, as a system, works. There is no panacea for this problem. Providing a mechanism for managing the parallel execution of machine operations, under the supervision of the cell host, will require an extended development effort.

The tasks associated with changing the cell for a different part family include:

- Down-loading new parts programs to the machine tools.
- Modifying fixtures. If the parts in the new batch are of the same family as the parts from the last batch, little or no modification is needed. On the other hand, if the new parts are substantially different then manual labor may be necessary for the modification.
- Installing different cutting tools. Just as modifications to fixtures are necessary if the part style is significantly different from the previous one, it may also be necessary to install different tools in the machine tool magazines,
- Providing statistical information, such as how long the machines have been running, how many incoming parts were processed and how many parts were rejected, to the factory management system.

These tasks are discussed in more detail in section 3A2.

The operations required for a cold start (after a power failure for example) form a special category. A cold start involves substantial manual labor. People will be starting machine tools, down-loading parts programs, and boot-strapping computers.

3.4.1. Steady State

A number of scenarios are developed below to describe the operation of the proposed cell. Each scenario is specific to some locale within the cell, but some of the scenarios may occur simultaneously.

Locating a part when it enters the cell

New parts will arrive at the cell sitting on a pallet that rides on a cart. The parts may be nothing more than lumps of metal bar stock or they may have undergone some preliminary machining, perhaps in another cell. The cart is moved beneath a vision system camera. This camera is equipped with a relatively wide angle lens and has a panoramic view of the parts sitting on the pallet. The parts will lie flat on the pallet, thereby reducing the problem of determining their orientation to a two dimensional one; which is something that a vision system is well equipped to handle. The ability of the vision system to determine the position and orientation of an object is embedded in the low level binary image processing algorithms shared by virtually all commercially available systems [Agin 82]. The low resolution image of an entire pallet full of raw parts provides sufficient information for the mill-loading robot to grasp the parts one at a time.

In figure 3-2 the robot places the parts upon a linear table. At this point a second camera may be used. The second camera is equipped with a magnifying lens, giving 5 to 10 times the resolution of the wide-angle camera. This magnification can improve the resolution of the image enough to determine the position and orientation of the raw part to within about ± 0.015 inch. Because the image seen by this camera is magnified, the field of view is reduced to an area on the linear table approximately 6 inches square. This reduction in the field of view prevents the camera from looking at more than one part at a time.

In figures 3-3 and 3-4 the position and orientation of parts can be established by placing the second camera over the parts-cart or by equipping the first camera with a zoom lens so that it can take both panoramic and close-up pictures. In either case, the camera must be able to move to different locations over the cart for the close-up pictures. The equipment required to move the camera to different locations over the parts would be about as expensive and complex as a linear table.

A third possibility is to establish the position and orientation of parts *while* they are held by the mill-loading robot. The robot grasps a part and holds it directly under the camera for a closer look. In this case there is no need to move the camera about. However, the scheme will not work unless grippers can be designed which do not obscure the part. It will also be difficult to load parts into precision fixtures on the machine tool if the parts are not precisely seated in the robot gripper. Merely knowing the position and orientation of the parts may be inadequate (*see Loading the mill*).

Crisping new parts.

Once the position and orientation of a new part are established to within ± 0.015 inches, it can be picked by the 5 or 6 axis mill-loading robot and loaded into a machine tool. In figure 3-2 the mill-loading robot may alternatively reposition the part more precisely on the linear table to accommodate later acquisition by the lathe-loading robot. The mill-loading robot must accurately locate the part in its gripper to do either of these tasks. Basically, we are relying upon the grippers and the fixtures in this cell to improve upon the ± 0.015 " positional accuracy by more than an order of magnitude.

The gripper will be of the type that tends to center a part as it closes. In this way the uncertainty in the part's position is slightly reduced. If the positional error is too large, the robot will have difficulty placing the part in fixturing on the mill or loading it accurately on the linear table. Several microswitches mounted in the gripper indicate whether the part is sitting squarely in it. If not, the robot releases the piece and grips it again. If this is unsuccessful then the vision system should take another look at the piece or the cell should request assistance. The process of accurately gripping the parts, one by one, and either loading them into the mill or repositioning them on the linear table is not a particularly fast one. For a higher volume cell some alternatives become worthwhile and these are discussed in section 3.7.

Grasping parts in-process

The requirements for grasping parts once they have been machined by one of the tools in the cell are somewhat different than those for new parts. In this case the parts may be sitting on the linear table (figure 3-2) or on the cart (figures 3-3 and 3-4). In either case, the position and orientation of the parts are now well defined because a robot has put them there. Consequently there is no need to use the vision system when picking them up again. At the same time, it is important to grasp the parts in a very precise and repeatable way. Once parts have been turned on the lathe or machined on the mill they become *precision* parts. They must be handled so as not to lose the precision invested in them.

The goal in grasping these parts is to ensure that the accuracy of the alignment between the part and the robot at least matches the working accuracy of the robot itself. If we know the greatest expected positional error of the parts we are able to design fixtures and program the robot accordingly. The smaller the error is, the easier these tasks will be. A number of micro switches will tell the robot whether a part is adequately positioned in its gripper. If not, the robot puts the part down and tries to grip it again.

Loading the mill

When the sensors on the robot gripper indicate that it has gripped the part, the robot proceeds to the mill. The robot guides or locates the part against fixtures so that the part is brought into nearly perfect alignment on the mill. The robot, with its accuracy of ± 0.008 inch, can only do this if there is some compliance in the mechanical system composed of the robot, the part, the fixturing, and the mill. It is helpful if the compliance

is not accompanied by substantial hysteresis and if contact forces between the part and the fixtures produce deflections only in the corresponding directions, with a minimum of side-effects. One way to accomplish this, and thereby reduce the likelihood of jamming or galling parts, is to use a Remote Center Compliance unit mounted just behind the gripper (*see clamps and fixtures, section 3.3*). The Remote Center Compliance is a passive device, originally developed to assist robots in assembling precision parts. It will soak up small angular and radial errors made by the robot that could otherwise produce high contact forces between a part and the fixture it slides into.

The reason for taking such pains to load parts accurately into fixtures is that unless they are positioned to within ± 0.0003 inch, there is no way to hold the required tolerances on most of them. The fixturing on the mill may need an expanding collet to hold the very close tolerances with respect to the internal diameters of parts such as the one shown in figure 3-1. It will probably be necessary to equip the clamps and fixtures on the mill with air nozzles. These would help to keep the clamping surfaces clean, and could easily be instrumented to detect the back pressure produced as the clamps pressed against the workpiece. Low back pressure would indicate imperfect contact due to dirt, metal chips, or misalignment of the part. The clamps should also be fitted with automatic brushes or air jets so that they can clean themselves when chips or dirt get in the way. In any event, the process of locating parts against fixtures and clamping them will require some trial and error experimentation before positioning tolerances of ± 0.0003 inch are achieved.

When the microswitches and pressure readings from the air nozzles indicate the part is properly clamped in place, the milling machine can begin cutting. If the sensors indicate that the part was *not* correctly loaded and clamped, the robot removes the part, lets the air jets or brushes try again to clean the surfaces, and loads the part again. If a part fails to load correctly after a few tries, the part is discarded. If several parts in succession, or a high percentage of parts over a period of time, fail to load correctly then something is wrong and the cell host requests assistance.

Machining

When a work piece is machined manually, the machinist monitors several machining parameters and adjusts the operation accordingly. The monitoring of any particular parameter is not continuous, but is characterized by the collection of discrete samples at a frequency high enough to reveal general trends. The machinist seldom reacts immediately to this information, but strives instead to extrapolate from these trends the actions that must occur in the near future and to perform them before the need becomes critical. Consider, for example, a milling operation in which the machinist is making successive cuts in a work piece at constant spindle speed, feed rate, and depth of cut. The machinist observes that an increasing amount of effort is required to turn the hand crank which translates the tool through the work piece. Based upon this observation, the machinist extrapolates the need to reduce the forces acting on the tool before it fails. At a

time determined by estimating the rate of change of this trend and through experience regarding how high these forces may become before the tool fails, the machinist acts to avoid tool failure. This action might be to increase spindle speed, reduce the feed rate, reduce the depth of cut, increase coolant flow, replace the tool with a newer and sharper tool, or some combination thereof. The desired result is to avoid scrapping the part and to eliminate a cause of unscheduled machine down-time.

The same monitoring and adjustment of machining parameters can, in a very limited way, be incorporated into a semi-autonomous, sensor-intensive machining cell. The key phrase here is sensor-intensive; what the machinist does with eyes and ears and touch, we emulate with sensors. To use the previously cited example, several techniques exist for measuring the gross forces experienced by the tool. Some techniques consist of instrumenting a part of the machine tool or the work-holding fixture with strain gages or piezoelectric force transducers. A less accurate approach is to monitor the (filtered) armature current of the machine tool motor.

Other sensor/machining-parameter combinations may be useful in emulating the monitoring activities performed by a machinist but they are beyond the scope of a near-term cell. Sensors, with their related support equipment (amplifiers, filters, analogue-to-digital converters, additional processor capacity, *et cetera*), are expensive. Furthermore, every sensor added to a machining cell adds to the complexity of the system.

We have not yet discussed how machining-parameter adjustments would be made in response to the various monitoring activities. It must be possible to make appropriate adjustments under computer control. If such variables as spindle speed, feed rate, and depth of cut are not software selectable, there is little point in monitoring indicators such as force, vibration, and temperature. A machinist does not bother to gather information that cannot be used and neither should our automated machine tools. An additional problem lies in deciding what is an "appropriate adjustment". The machining programs will have to use a mixture of empirical and simple analytic formulae. To date, very little software has been developed in this field.

Eventually it should be possible to monitor and respond to changes in a variety of machining parameters so as to optimize the unmanned operation of a machine tool. The most promising possibilities are discussed in section 3J. A realistic approach is to begin by ignoring most of these parameters and assuming, for example, that a new tool will last some fixed number of parts. The goal is to automate the actions of our hypothetical machinist incrementally, as the cell evolves and matures.

Unloading the mill

After a workpiece has been machined it is removed by the robot attending the mill. If the part requires further machining on the lathe then the robot in figure 3-2 places the part onto the linear table. In figures 3-3 and 3-4 the robot may take the part directly to the lathe or, more often, will place it upon the cart, waiting

for the lathe to become available. The accuracy required for unloading the mill is not high but the robot should nonetheless be programmed to grasp the part and to set it down as accurately as possible. This is because we wish to preserve the accurate orientation of the part that we worked so hard to achieve earlier. Whether part proceeds to the lathe or to another cell, it will have to be picked up by another piece of automated equipment and loaded into another machine for precision processing. The better the orientation of the piece is known, the easier this task will be.

Loading the lathe.

For the cell arrangements shown in figures 3-3 and 3-4 the 5 or 6 axis mill-loading robot is also used to load the lathe. In this case the mechanics of loading a part into the lathe are essentially the same as those described earlier for the mill.

For the cell arrangement given in figure 3-2 things are different. When parts are ready to be turned on the lathe, the linear table slides over to a position beneath the lathe-loading robot. The lathe-loading robot is only able to pick parts from one position. This means that the linear table must index to present sequential rows of parts to it. It also means that when parts of a new style are loaded they must be placed so that their center lines match those of the previous parts. The alternative is to manually reset the fixed reach of the robot.

The lathe loading robot uses sensors to verify that it has gripped a part correctly. Like the mill loading robot, it needs to grip the part accurately. Next, the robot arm retracts, and the carriage travels to a position above the lathe chuck. The amount of carriage travel is programmable, and can be automatically changed to suit different part lengths. The arm extends, stopping when the centerline of the part and chuck coincide. The arm extension is not programmable and therefore, if the robot is to load different parts without manual readjustment, the gripper must grip different cross sections without producing offsets. The need for such a gripper has been met in other applications with a couple of simple designs [Qingsen 82]. The robot carriage travels a short distance until the part bottoms out in the chuck on the lathe. The jaws of the chuck then close upon the part. As the above discussion reveals, the lathe-loading robot while inexpensive and rugged, is less suited to flexible operation than the mill-loading robot.

Loading the lathe with raw bar stock does not require extreme accuracy since the bar stock is oversize. Much more difficult tasks are: Reversing a part in the chuck of the lathe and loading a part that has already had some precision milling done on it. In either of these cases the accuracy of the finished part is a direct function of the position of the part in the lathe. As with the fixtures on the mill, it becomes vital that the jaws all meet the surface of the part squarely and that no chips or dirt get between the mating surfaces. Again as on the mill, it is useful to detect misalignment by monitoring the back-pressure of air jets at the clamping surfaces.

Reversing a part in the lathe poses a special problem for items such as the part shown in figure 3-1. These items are too short to be gripped from the side and must be held by one end or the other. For the arrangements in figures 3-3 and 3-4 this means that the parts must be removed from the lathe, set into some holding fixture, re-gripped from the other side and loaded back into the lathe. For the arrangement in figure 3-2, one arm of the lathe-loading robot can remove the part from the chuck, swivel 180 deg. and present the part to the second arm of the robot which grips the part from the other end. The second arm then loads the part back into the lathe chuck. This is one advantage to the lathe-loading robot. Whichever cell arrangement is used, the part is either gripped or clamped three times in this process and it will be very difficult to maintain orientation.

Transferring a part between the lathe and the mill

In figure 3-2 parts travel between the lathe and the mill on a linear table carrying a pallet. The pallet will have some very simple locating fixtures to help the robots put parts down in a repeatable way. The linear table is a simple, but precise, device that travels in a straight line (*see section 3.3*). We take advantage of its precision, indexing it so that sequential rows of parts on the pallet are placed directly beneath the lathe-loading robot. The mill loading robot is more sophisticated and could be programmed to pick up parts from different rows on the pallet, but it is simpler and more precise to let the linear table do the indexing. Mechanical or optical switches indicate the position of the linear table, unless it has a continuous linear readout of position. Additional optical switches are placed where they will detect the presence or absence of parts on the linear table. These switches are a safety measure, verifying that a part really is present when it is presumed to be present and that an ostensibly vacant spot on the pallet really is vacant.

In figures 3-3 and 3-4 the mill-loading robot is responsible for transferring parts between the mill and the lathe. In figure 3-3 the robot rides on linear track. Ideally, the track should be treated as an extra axis for the robot, and equipped with a continuous linear readout of position.

Inspection of the completed part.

Upon completion of the machining a part, it is necessary to measure the machined dimensions to ensure that none fall outside some acceptable range for assembly into a finished product. In a typical job or batch production environment this is accomplished through manual inspection of the work piece by an individual using such measurement tools as micrometers, calipers, height gages, and so on. In our pursuit of an autonomous machining cell we would like to automate as much of this process as possible.

In addition to determining the fitness of a particular work piece for inclusion in a final product, the inspection of parts can be used to diagnose the state of the manufacturing process. Some clues are provided by the sensors located within the machining cell. Even a great many sensors, however, cannot monitor all of

the variables that might cause failures. It is therefore ideal to extend the inspection of the finished part to the detection of symptoms of manufacturing failures [Bourne 82b]. An example of this can be seen in the way a worn end mill in the milling machine produces a final dimension that is larger than the same dimension on an earlier work piece machined when the tool was not worn. If the cell host has been storing the dimensional data measured from previous workpieces, it not only knows that a particular dimension is oversize on the current workpiece, but also that previous work pieces have been exhibiting a trend towards this state and the tool may therefore be wearing out.

As mentioned earlier in section 3.1, final part inspection within this cell is restricted to automated visual inspection of those features which can be discerned from a profile view of the work piece. It is possible to compare these features with a previously developed data base which describes the desired or theoretical appearance of the object.

In section 3.3 it was pointed out that the resolution, or fineness of detail which can be discerned by a vision system is dependent upon the pixel density of the imaging element in the video camera. In addition, the system's resolution will be affected by magnification and by the presence of any aberrations or constructional defects in the optics used with the video camera. The resolution of the vision system is particularly important when one is attempting to use it to make dimensional measurements. The ± 0.015 " resolution of the second camera described in *Locating a part when it enters the cell* is clearly too coarse for inspecting the machined dimensions on precision parts. A camera with a higher magnification would have a finer resolution but with a corresponding reduction in the field of view.

3.4.2. Between Part Runs

In the ideal flexible cell, the only task between part runs would be to load new programs into the machine controllers and cell host; and this would happen automatically. In a practical cell there are also a few manual tasks. The less flexible the cell, the longer they take. For the cell we describe, the tasks are as follows:

- Modify the cell fixturing to align and clamp the new part shape. If the new parts are very similar to the parts in the last batch then the fixturing is not modified at all. On the other hand, if the new parts are quite different, people will have to readjust or reconfigure all the fixtures. In the extreme case, new grippers will be bolted to all the robots and new clamps and fixtures placed on the machine tools.
- Run a few parts through the cell, step by step, with people watching the process and inspecting the parts. This precaution is most important when the parts in the new batch are not very similar to those of the last batch. Running a few parts through, slowly, allows us to verify that the programs are all good, and that the readjusted fixturing performs successfully. If the cell were more sophisticated, it could be asked to run a few trial parts by itself and could rely on its sensors and inspection equipment to check that all went well.

Transfer of parts programs from the host to the controllers.

The cell host will provide the controllers with their programs. The cell host won't store those programs, but will receive them from the a higher level computer. The heaviest traffic in machine program transfers (whether CNC part programs or robot movement programs) will occur between batch runs. Most of the controllers are capable of storing several programs at one time, so they will not need to be refreshed during the parts run.

The machine controllers will be able to support file transfers between themselves and the host. They will be able to do this without operator intervention. When the time comes for a changeover of controller programs, the cell host will tell each controller to accept the new program and then the host will ship the program. As is the case with file transfer protocols between full-fledged computers, the transfer software will guard against transmission errors. If an error is detected the two processors, host and controller, will correspond and re-ship the parts program.

The ensemble of programs that the controllers in the cell require is defined by the particular part being machined. A computer at the manufacturing system level will be responsible for maintaining the database of programs and for relating parts to the programs required to make them.

Replacement of tools.

An automated cell should treat cutting tools much like parts. New tools will be automatically loaded between part runs and tools that are worn, or that will not be used for the next part run, will be removed. To some extent, the vision system will be able to identify and locate new tools in the same way that it does for parts. The utility of the vision system will be limited, however, because cutting tools do not lend themselves to two dimensional visual location as easily as parts like the one shown in figure 3-1. Another problem is that the robot grippers will have been carefully designed to handle a limited family of precision parts, and not tools. A way to get around this problem is to mount the tools in adaptors so that the robots can handle them. It would be easy enough to design the adaptors to also help the vision system locate the incoming tools.

Tools loaded into the mill will probably be inserted into a loading position on the tool changer. At this point it will clearly be necessary for the tool adaptor to release the tool. One simple solution is for the tool adaptor to be spring loaded. Similarly, tools for the lathe will be loaded into the turret. For the arrangement in figure 3-2 this requires positioning the turret so that one tool holder location is on the same centerline as the chuck. Otherwise the lathe loading robot would have to be manually readjusted. Here again, we see that the choice of a dedicated lathe-loading robot results in a less flexible system. In any event, it may be easiest to resort to manual tool replacement while the cell is in its earliest stages.

If a tool fails *during* a part run (and if there are no spares in the tool changer) we have a less tractable problem. It is difficult to introduce a new tool while the machines in the cell and the area beneath the vision system are full of parts. In this case it is easiest to inform the cell host that a new cutting tool will be manually introduced. The cell host halts the cell equipment, if it has not already done so, and waits for a signal that the tool exchange is complete.

Creation of new parts programs.

Modification and testing of parts programs will typically occur between part runs. The cell is not responsible for creating or storing parts programs, but it is useful to establish the programming requirements for the machines in this cell and to look at the tasks involved in testing new programs. A variety of commercial packages are available to generate parts programs but program generation represents only a portion of the required effort. The verification of new CNC programs is currently done on the actual machine tools and the time spent testing programs is lost production time. Generally, the techniques for program creation and verification differ for each tool, depending on the complexity of the controller. For the tools discussed in section 3.3 the procedures are listed below:

- ***For the CNC machine tools.***

A large number of software tools are available to create parts programs from some user input. The parts programs can then be down-loaded to the machine controllers. The systems that create parts programs vary in complexity from full blown CAD systems to simple, stand-alone programming aids. Even the latter are worthwhile in terms of parts programmer productivity.

- The generation of parts programs for CNC machine tools is a straightforward problem since most CNC machine tools are programmed in a derivative of the APT language. The structure of APT programs is simple and very amenable to automatic creation.
- The verification of newly created APT-like programs is not as well defined as their creation. Some sophisticated geometric modeling techniques exist for checking tool paths and such, but the final program is still checked on the machine tool.

- ***For the multi-axis robot.***

The state of the art in program generation and verification in robots is more primitive than that for CNC machine tools. As above, machine time will be lost during verification of a new program, but more time will be lost during the creation of the program. The current method for creating robot programs is to manually teach them the motions desired in their work space. The programs can be tested only on the same robot. Some work is being done on the problem of robot program generation, but the efforts are still largely in the research arena. For the near-term cell we must anticipate cell down-time when new robot programs are being written, de-bugged, and tested.

- ***For the transportation device in figure 3-2.***

The linear table in figure 3-2 will probably be controlled by a commercially available programmable controller (PC). The programs for such devices are simple ladder diagrams input through something typically called a "program loader." The program loader is a terminal paired

with software to convert the user input into machine language. The program loader is designed to send its machine code directly to the programmable controller but the output can also be re-directed to some storage device and later down-loaded to the linear table controller.

The general issue of programming the linear table is not critical in the same way as that for the milling machine, lathe, or mill-loading robot. The programmable table will take its orders from the cell host. Those orders will be commands to move to some pre-defined location. The program residing in the programmable controller is, therefore, a simple program that interprets the host's command into proper signal levels and times for the DC servo motors that drive the table. There will be no pre-programmed sequence of motions in the table controller. Those sequences must come from the cell host.

- ***For the lathe-loading robot***

The controller for the MANCA lathe-loading robot mentioned above (see section 3.3) has the same general capabilities as the linear table controller. The specifics of the program ladder diagram will differ, but the basic technology is the same.

3.5. Skills needed to Develop and Maintain the Cell

A flexible manufacturing cell requires an amalgam of conventional manufacturing skills and computer expertise. The mixture of equipment and techniques in the cell impose demands that are best solved by an eclectic group. The skills described below will be needed most while the cell is developed. After the cell is running smoothly they will occasionally be in demand for trouble-shooting and modifying the cell.

The mechanical equipment can be treated in much the same way as high-volume automated machinery is debugged and maintained today. Instead of compiling an exhaustive list of all the mechanical tasks involved in setting up, debugging, and maintaining a cell we focus on those that are *not* found in more conventional forms of production. The main features that distinguish equipment in a cell from other pieces of automated machinery are their complexity, their flexibility, and their physical interaction. For example, installing and maintaining robots requires some knowledge of the controller, the servo system, and the mechanical components. If something goes wrong it is important to know which of these systems is most likely at fault. Furthermore, the robot in this cell is not a stand-alone machine; it communicates with a host computer and it interacts physically with other pieces of equipment. It is important to have a global view of the robot as, well as a robot repair technician's view, when working on the robot.

The cell we have described produces precision parts, and this calls for *special* attention. Do how *trims* accumulate as a part moves from one process to the next. For instance, when the perpendicularity of two surfaces *m* a part starts to deteriorate there are many possible contributors to the problem. The axis feedback on the milling machine might be in error, or the end mill might be deflecting. The fault may lie with the filtering on the mill. The fixturing can slightly shift with respect to the mill, or the sensors on the fixture can indicate that the part is aligned when, in fact, it is not. If the sensors on the **fixturing** do indicate a problem

then the robot, or its gripper, may be at fault. The part may be poorly aligned during its acquisition by the robot. The gripper is equipped with sensors to detect this condition, but they can fail. The possibilities continue beyond this list. The problem is to find the things which can be re-adjusted to improve the final accuracy of the part. Its solution is greatly aided by a thorough understanding of how the processes and equipment interact. Much of this understanding will have to be acquired during the initial operation of the cell.

When the cell is first set up there will be a large amount of mechanical de-bugging to do. The design of fixtures is expected to be an ongoing and iterative process.

The development of the software and hardware to control the cell will require skills that are needed in any computer environment. The exceptional requirements for an application such as this are centered on the problem of integrating the computer and the machining worlds. For example, there will be development problems getting from the cell host into the machine controllers. The creation of the protocols and programs to achieve this will entail a great deal of initial effort. The effort can be eased by people with skills involving low-level interfacing of computers. The cell host will have the responsibility of assuring that no un-toward physical interaction occurs (like the robot running into the mill table). The software to support this duty will not be simple and will require the skills of a high-level program designer. The amount of programming to be done in the cell is large and will require several programmers. The managers for this project will be required to understand and communicate with people from two very different backgrounds: computers and machining.

3.6. Problems

Flexible manufacturing cells may be plagued by a number of common problems. Some of these stem from design errors and are largely avoidable. Others are errors that occur during cell operation and require the design and implementation of contingency plans.

3.6.1. Design problems

It is unlikely that we can anticipate all of the problems associated with designing a cell but we list a few of the most common design pitfalls below:

- **Flexibility versus Productivity** - The components of the cell can be designed to maximize either of these criteria but not both. It is therefore important to decide from a production standpoint how flexible the cell should be and what its productivity should be. All components of the cell should then reflect this compromise. There is no point in designing extremely adaptable fixturing if the supervisory control system for the cell is not flexible, and vice-versa.
- **Failures** - Occasional failures must be anticipated. A machine may fail to operate correctly or a

procedure may fail to take place as expected. Failures can result from many causes including equipment breakage, faulty incoming parts and robot drift. It is probably acceptable to scrap a part (or in a severe case, a whole batch of parts) but the equipment in the cell should not be allowed to seriously damage itself.

- **Critical Items** - Evaluate how crucial each component is to the partial operation of the cell. If the lathe is out of commission then the cell can still do parts that require milling. If one of the robots is out of commission then parts will have to be fed by hand. If the supervisory computer is out of commission then the machine tools and robots can no longer function as a cell. In the case of very critical components, such as the host computer, there should always be spare parts on hand. Sensors, such as limit switches used to determine the presence of a part, should be made redundant so that if one fails then the desired information will still be available.
- **Cell Host Extensibility** -- The designers of the cell host will certainly not think of everything the cell "should" do. They will probably avoid doing things that are just plain wrong, but experience in working with the cell will illuminate areas that need additional support. The programs running on the cell host must be easily changed. Their integration into what has been called the cell supervisor must be clear and well structured so individual programs can be easily modified and extended. In particular:
 - There must be a straight-forward procedure for changing the way the cell supervisor sequences the machines in the cell. More than any other operational feature, the sequencing of the machines in the cell will need to be adjusted.
 - The understanding of run-time errors will grow (probably exponentially, at first) with experience. The software to handle the errors should be designed to make it straightforward to add new routines and modify old ones. In addition, the hardware must allow for expansion of the software. A cell host that seems just adequate for the cell at design time will probably soon be bogged down with un-anticipated sensor handling routines.
 - The type of data the supervisor keeps track of will be fairly well understood at design time, but the individual pieces of data almost certainly won't. This is particularly true for the statistical data which is sent to the manufacturing system computer. Additional sampling of random run-time data should be easy to implement.

3.6.2. Runtime problems

Runtime errors will occur in any cell, although they can be reduced by proper design. The cell must be able to recover from minor errors and must at least be able to avoid damaging itself when confronted with serious errors. Runtime errors include broken cutting tools, dropped parts, misaligned parts, machine tool failures and computer crashes. The near-term cell described above is a minimum configuration cell and its response to most of these errors will be to allow one or more parts to be scrapped. One problem with a minimum configuration is that the consequences of any given error are more severe for the cell as a whole. Thus, it is especially important to design durable and perhaps redundant components for the cell.

3.7. Alternatives for the Future

The functions and equipment for the cell described above are by no means exclusive. Various alternative configurations can be used to increase flexibility or productivity. For example, the machining cell becomes considerably more versatile if a four or five axis machining center is used in place of a vertical axis CNC mill. The much greater expense of a machining center is not justified for machining parts from the family typified by figure 3-1 but it would allow the cell to tackle complex parts that require too many set-ups with a vertical axis mill or that require contour cutting. As a second example, the lathe could be replaced with a multi-spindle chucker which would considerably increase the number of turned parts per hour. For many small-batch precision parts, however, high production volumes are not an issue.

The way in which the cell locates and then acquires new parts is flexible, but slow. The vision system looks at each part, determines the coordinates of the part, and sends them to the cell host. The cell host then sends them to the mill-loading robot which carefully grips the parts and transfers them, one by one, to one of the machine tools. A faster approach is to use a pallet with fixtures to hold the parts so that they arrive at the cell with a known orientation. The pallet and cart may be aligned with mechanical locating devices, or the pallet may be located using the vision system - just once. This approach makes less use of the vision system, and is less flexible since it presumes that parts are accurately located on the pallet when they arrive. However, if the parts have arrived from another cell they will have been put down in a systematic and accurate fashion. The only other requirement is to design the pallet so that the parts do not jostle while they are transported. The vision system is used only to count the parts, and check that they match the expected description. Even if the vision system is used to establish the position and orientation of parts, it is still advantageous to begin with a known approximate part orientation. This reduces the likelihood of ambiguous part orientations and can improve the speed and accuracy of the solution.⁴

The sensors used in the cell could include pressure sensors, force sensors, vibration sensors, and optical measurement equipment. These devices would allow the cell to check for problems and do some rudimentary troubleshooting. For example, proportional sensors such as LVDTs or pneumatic gages on the fixtures could display not only whether parts were aligned but how well they were aligned compared to previous parts in the batch. Once random noise is filtered out of such measurements, they become very useful in indicating trends such as a gradual deterioration in robot accuracy or fixture performance. The goal is to discover such trends before they become a serious problem.

Sensors can also be used to monitor the processes within the cell in an effort to optimize them. For example, in the machining process one might emulate some of the senses that an experienced machinist uses

⁴This technique has been demonstrated in recent work by researchers at the University of Rhode Island

when running his machine. Thus, in an attempt to automate a machinist's use of tactile feedback, accelerometers could be mounted in strategic locations on the machine tool to measure the vibration of the system composed of the machine tool, fixture and work piece. This information would be used to identify speeds, feeds, and fixture configurations which maximize chip removal while minimizing vibration. While a machinist might judge the rate of power consumption of a machine tool by listening to the spindle drive motor, a volt meter in combination with an ammeter could measure the drive motor's power consumption. Checking work piece dimensions, a simple matter of reading a value from a caliper or micrometer for a machinist, might be accomplished with displacement transducers mounted in specially designed tool holders. This, however, has the drawback of being limited by the accuracy of the machine tool itself and occupies the machine with measurement tasks when it could be cutting metal. The list can be extended to increasingly obscure parameters that are normally monitored by a machinist operating a milling machine but until better theoretical models of the machining process are available there is little point in monitoring any but the most basic variables.

The devices mentioned above are more delicate than the simple sensors specified in section 3.3 and they often require expensive signal processing electronics; but the real reason for not including them in the first implementation of the flexible cell is that they require sophisticated software support for control and diagnosis- A considerable amount of research and development would be required to produce such software-

Most of the alternatives to the near-term cell, including those mentioned above in this section, would increase the first cost of the cell. There are very few alternatives that will decrease the cost of the cell because a minimum cell configuration has been selected. The one exception to this rule is to wait. We can wait until machine tools become more flexible, until controllers become more powerful and versatile, until the software required for flexible cells is less novel, and then the cost of the cell will go down. Unfortunately if we do wait, we are no longer building the "Factory of the Future." Also, many of the development costs pertain to the first cost of the *first* cell. Once a couple of cells have been built, the development costs become minor.

4. Cell Integration into a Manufacturing System

Integrating the cell into a larger manufacturing system is basically a step up the system hierarchy of figure 3-5. Now the problems become ones concerning the cell as a whole (or, to use the earlier lexicon, a module). This purpose of this *section* is not to provide a detailed set of guidelines for the system design but to consider the most important features of the system and to discuss the relationship between the cells and the system.

4.1. System Definition

The system should be usable as a building block for a complete factory. Like the cells beneath it, the system will be a module with a defined input and output. It will depend on the next higher level of the hierarchy for certain services such as inventory, engineering support, and scheduling. This division has also been recently proposed by W. Eversheim [Eversheim 82]. We expect the system to be semi-autonomous, as are the cells.

4.2. System Capability

Initially, the manufacturing system may consist of just one or two cells but with expansion and flexibility in mind the initial design should at least have provisions for incorporating the following features:

- The system will monitor material flow within its boundaries. Whether the parts are moved manually or automatically from one cell to the next, the system should be able to keep track them.
- Information as well as materials will flow from cell to cell. The system will be responsible for coordinating the information passage. For example, when a batch of parts travels from one cell to another it is accompanied by descriptive information. This is done so that the destination cell knows how many parts are in the batch, what their description is, what their orientation is, and so on. At first, information giving the part description and orientation may not be used since the cell program will assume a particular orientation for a particular part type. As cells become more sophisticated they will assume less. Instead, they will rely on their sensors, aided by the information accompanying the parts as they enter the cell.
- The manufacturing system will store and maintain programs associated with producing the families of parts. In particular:
 - o The system level computer will be responsible for maintaining the repertoire of part programs used by CNC machines in the cells.
 - o Likewise, the cell hosts require a variety of instructions from the system. The sequence programs, for example, for a given part will come from the system level computer.
- The system will be responsible for maintaining the statistics for the cells and machine tools. These are the usage, maintenance, and history statistics that are necessary for autonomous operation.
- One of the more important functions of the system level supervisors should be the capability to gracefully degrade the system as individual components fail. The system should also be able to *recover* from failure when the components are repaired. A thorough discussion of a way to address these issues is given by Fox [Fox 81].

The system may be a very large and versatile collection of cells, but it is not a factory. In particular* the following operations lie beyond the scope of the manufacturing system:

- The retrieval and initial processing of raw materials is done outside the system* For example* the bar stock used for the family of parts discussed in section 3 is usually delivered in 20 foot tang

sections. Handling these sections and cutting them to a more manageable size are operations that lie outside the manufacturing system.

- Inventory and its control are handled outside of the manufacturing system. In-process parts are controlled by the system, but storage of the finished parts and storage of the bar stock and bar stock sections are controlled at the factory level.
- Maintenance functions required in the factory are not part of the system. These include the maintenance of the machines, robots, and computers, and also of the software required to run them.
- The CAD/CAM (Computer Aided Design/Computer Aided Manufacturing) system mentioned in section 3.4.2 will reside in computers outside the manufacturing system. The manufacturing system computer will store parts programs and sequence programs but will not be used for designing parts and generating CNC programs.

Figure 4-1 schematically shows the relationship between the manufacturing system and the operations listed above.

4.3. Modifications at the Cell Level

The modifications to a machining cell that transform it from a solitary, developmental cell into a member of a manufacturing system are not difficult. The design for the cell specifies input and output for the cell, and these are services that the manufacturing system provides to the cell. The cell has been designed so that virtually no modifications in the cell equipment are required. In fact, the performance demanded of individual machines in a cell may reduce as the number of cells in a manufacturing system increases. Redundancy makes each piece of equipment less crucial to the function of the system as a whole.

The main modification of the cell will be to the cell host. A communication channel between the manufacturing system and the cell host must be established. The communication channel will be via the local network of the factory and the cell host must be given the software and the hardware to use it. The cell host will receive its instructions and programs from the manufacturing system computer instead of its own on-line storage.

4.4. System Components

The most important components of the manufacturing system are the cells that it comprises, but some additional components will be needed to tie the cells together:

Inter-cell materials handling devices.

The devices responsible for transporting components between the cells in a manufacturing system can take

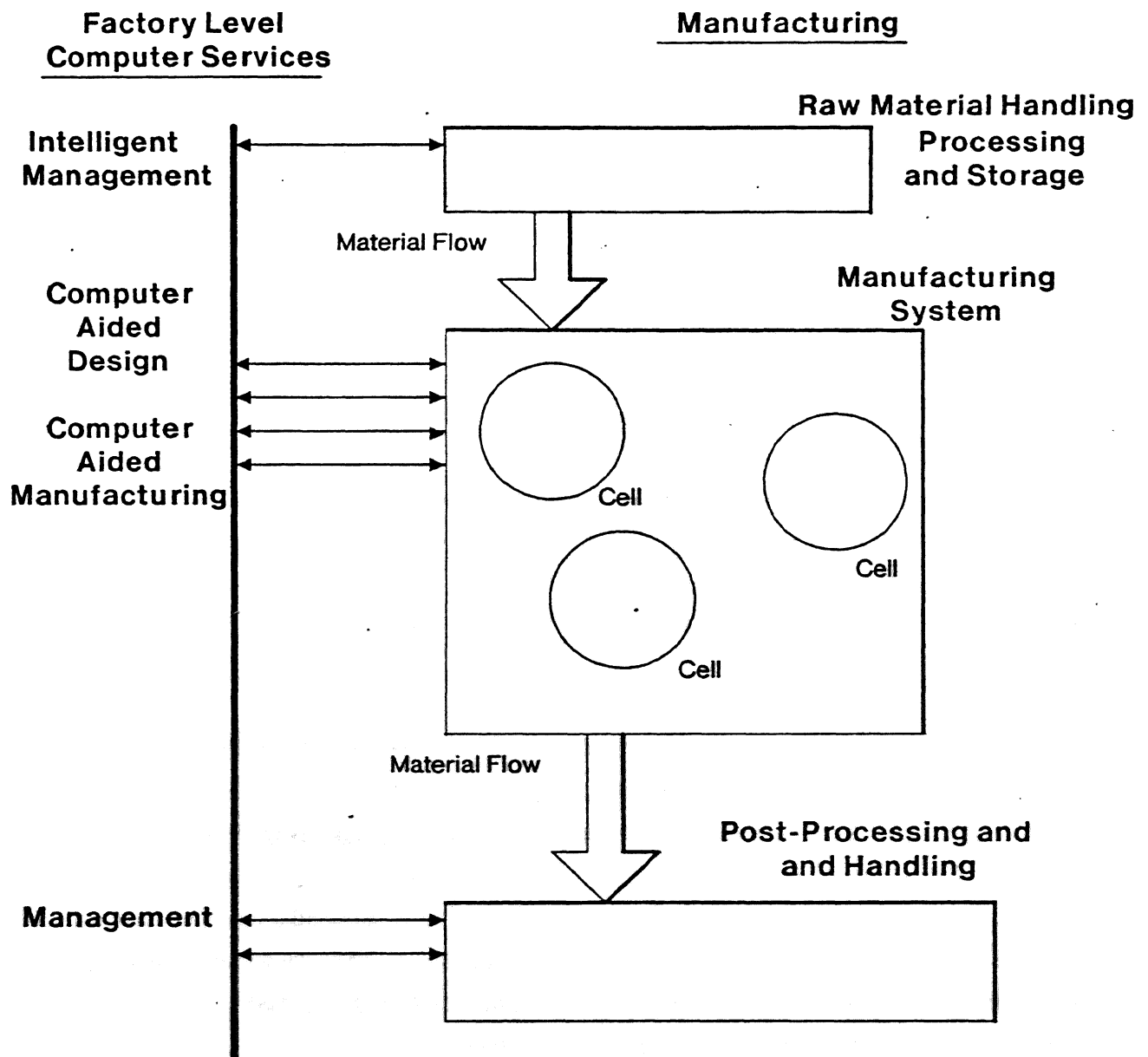

Figure 4-1: A Schematic of the Manufacturing System and the Factory Support Environment

many forms. The traditional conveyor-based systems are expensive and difficult to maintain. The newer developments based on robot trucks, for example, also require a large capital investment [Edkins 82]. The success of the system depends most on implementing the cells correctly. Achieving a completely unmanned material flow is less important, and initially we allow the handling of materials between the cells to be manual. To use robot trucks requires not only the very high initial expense of the carts and their guiding apparatus,

but also the development of an intelligent, automated system for controlling them. Sensors are required to keep track of where the individual carts are at any given time, and what parts they are carrying. Batches of parts will enter or leave the cells only at occasional intervals, so the autonomous nature of the cell and manufacturing system is not too compromised.

The manufacturing system supervisory computer.

The supervisory computer for the manufacturing system will fill much the same role for the system that the cell host computer does for the cell. A few of the more important chores performed by the system computer are listed below:

- Schedule the flow of parts between the cells within the manufacturing system.
- Direct the flow of information concerning the parts.
- Store the CNC part programs (for both the CNC machine tools and the robots) in a on-line storage facility.
- Maintain a database that relates particular parts to the programs required to make them.
- Supply the part programs to the cell host when a new part is sent to a cell.
- The manufacturing system computer must also provide the cell host with its operating software. If the cell hosts need software support each time they are booted, then the system computer will be responsible for that too.
- The statistics arising from the individual cells will need to be compiled, compressed, and analyzed by the manufacturing system computer.
- The software for gracefully degrading the system as one or more cells experience problems will reside in the system computer.

The computer to accomplish these functions will need to be a fairly substantial machine. A Digital VAX 11/780, or comparable equipment, should be sufficient for most systems. The computer will be running some advanced software, so the same caveats apply to this system that apply to the cell host, *i.e.* it should run a good operating system that can support program and system development.

If there is only one cell, a single computer could act as both the cell host and the manufacturing system supervisor but there are some arguments against doing this. First, the entire production floor will become dependent on a single device. Although reliable, today's computer technology does fail now and again. Such a failure could have serious effects on the system productivity. Second, future expansion will require a separation of computing power (one machine will not economically support the whole load). Many headaches can be avoided by separating the two supervisors (cell and manufacturing system) from the

beginning. And finally, the separated supervisors will be more marketable as separate products. A good cell host with the proper software is a product not available on today's market. It should be.

Network links.

The system computer will communicate to the cells over a factory wide network. The technology for Local Area Networks (LANs) is developing rapidly. Most computer manufacturers are building some sort of network or interface to an established network. The manufacturing system, the cells and the factory should capitalize on the new LAN technology.

The Institute of Electrical and Electronic Engineers (IEEE) has established a Committee to propose a standard for LANs. That committee, the so-called 802 committee is now promulgating three preliminary standards. The third of those, IEEE-802-3, is essentially compatible with the network known as Ethernet [Shoch 82]. The effect of the IEEE proposal will be primarily felt within this country, but the technical press is mentioning Ethernet as the *de facto* standard for LANs [Andrews 82, Koopman 82]. In addition to being accepted by the industry, Ethernet is a reasonable networking system. It was developed by Xerox in about 1972 [Shoch 82] and is now being marketed by Xerox, Dec, and Intel (primarily). The factory is a harsh environment for computer networks, and at least one consortium has implemented a fibre-optic version of the Ethernet [Andrews 82]. The optical nature of the transmission medium (the 'ether') is much less susceptible to electromagnetic interference than is the original coax cable.

The hardware and transmission protocols are only part of the networking system, though. The software to support the LAN at each computer must also exist. Typically, the software to support a complex system is ^{la} the hardware implementations (a truism of software engineering). The software for the Ethernet is well advanced and will probably be available by the time anyone wants to implement a system such as this.

Another possibility is to use one of the systems which is marketed by a single vendor. DECnet [Wecker 80] and IBM's SNA (Systems Network Architecture) [Cypser 78] are two examples. The major problem with such an approach is the restriction to one vendor's computers for the whole system, or the special development of interfacing software. Given the wide variety of computers within the manufacturing system and the even wider variety of tasks, there is much to be said for using a network system that will be a US standard.

The last factor for consideration here is the way the LAN will adapt to the growth of the manufacturing system. The small manufacturer will probably not invest in a full-blown CAD system until the price drops considerably. Nonetheless* the original choice for the LAN should not later restrict the choice of CAD systems* Similarly, machine tool makers will be implementing links to LANs at some point in the future.

When this occurs, the serial links in the manufacturing cells may be replaced with a faster LAN scheme, provided that the LAN originally chosen for the manufacturing system is compatible with what the machine tool builders offer. The adoption of a US standard is advisable both cases.

5. Summary

The prospects for machining cells and automated manufacturing systems are exciting. If they can be integrated with factory support tools such as computer aided design and factory management, their power and utility greatly increase. For the most part, the technology that is used in a truly advanced system is available today. Much work, though, must be done to build the system components and then integrate them into the system.

We have focused on the design of a cell because a cell illustrates most of the problems involved in designing an automated factory. We treat it as the fundamental building block for an automated factory. The cell we describe is a near-term cell -- something one could start to draw the plans for today. Indeed, we provide the structure for those plans here. The constraint of the near-term cell, though, forces some compromises that reduce the sophistication of the cell and keep it from being completely autonomous. The compromises can be eliminated as more advanced equipment, and some working experience, become available.

Even a near-term cell requires a few amenities which are not commercially available. The builder of a semi-automated manufacturing cell should be prepared for some development work. The effort is modest however, and will consist of extensions to currently available hardware and software. The result is a machining cell that can gracefully grow with the development of new technology in robotics.

6. Acknowledgements

An effort to define what should come ahead can only be done with guidance and in an environment that promotes scholarship and speculative thought. The authors thank Prof. Paul Wright for the former and gratefully acknowledge Carnegie-Mellon University and the Robotics Institute for the latter.

References

- [Agin 82] Gerald J. Agin.
Image Processing Algorithms for Industrial Vision.
April 6, 1982.
- [Anderson 82] Gordon Anderson and Kenneth Shumate.
Selecting a Programming Language, Compiler, and Support Environment: Method and Example.
Computer 15(8):29-36, August, 1982.
- [Andrews 82] Warren Andrews.
Ethernet Seen As LAN Standard.
Electronic Engineering Times :1, September 27, 1982.
- [Bjorke 79] O. Bjorke.
Computer-Aided Part Manufacturing.
Computers in Industry 1:3-9, January, 1979.
- [Bourne 82a] D. A. Bourne and P. S. Fussell.
Designing Programming Languages for Manufacturing Cells.
Technical Report, The Robotics Institute, Carnegie-Mellon University, April, 1982.
- [Bourne 82b] P.K.Wright, D.A.Bourne, R.Milligan.
Fault Analysis In A Flexible Manufacturing Cell.
Proc. of the 23rd Machine Tool Design & Research Conf., Manchester, England, September, 1982.
- [Bourne 82c] David A. Bourne, Robert Milligan Jr., and Paul K. Wright.
Fault Detection In Manufacturing Cells Based on Three Dimensional Visual Information.
Proc. Conference of the International Society for Optical Engineering(SPIE), Washington, DC, May, 1982.
- [Cypser 78] R. J. Cypser.
Communications Architecture for Distributed Systems.
Addison-Wesley, Reading, Mass, 1978.
- [Edkins 82] M. Edkins, et al.
An Evolutionary Flexible Manufacturing Cell.
In *14th Seminar on Manufacturing Cells and Their Subsystems.* CIRP -- International
Institution for Production Engineering Research, Faculty Press, Ljubljana, Yugoslavia,
June, 1982.
- [Eversheim 82] W. Eversheim, U. Muller, L. F.Koch.
Manufacturing Cells in Unmanned Production.
In *14th Seminar on Manufacturing Cells and Their Subsystems.* CIRP -- International
Institution for Production Engineering Research, Faculty Press, Ljubljana, Yugoslavia,
June, 1982.

- [Fox 81] Mark S. Fox.
The Intelligent Management System -- An Overview.
Technical Report CMU-RI-TR-81-4, Carnegie Mellon University, The Robotics Institute,
August, 1981.
- [Gevarter 82] W. B. Gevarter.
An Overview of Artificial Intelligence and Robotics Volume II.
PB82-204439 NBSIR 82-2479, National Bureau of Standards, March, 1982.
- [Gossard 80] D.C. Gossard, D.E. Hardt, F.A. McClintock, B.T. Allison, I. Gu and K. Stelson.
Discrete Die Surface For Sheet Metal Parts.
ICAM End of Contract Briefings, Wright-Patterson AFB, January, 1980.
- [Gunn 82] T.G. Gunn.
The Mechanization of Design and Manufacturing.
Scientific American 247(3):129, September, 1982.
- [Houston 81a] G. E. Houston and L. B. Brown.
Robotic System for Aerospace Batch Manufacturing.
Tenth Interim Technical Report IR-812-8(X), McDonnell Douglas Corporation, February,
1981.
pages 5.2.1-5.2.6.
- [Houston 81b] G. E. Houston and L. B. Brown.
Robotic System for Aerospace Batch Manufacturing.
Tenth Interim Technical Report IR-812-8(X), McDonnell Douglas Corporation, February,
1981.
pages 5.3.1-5.3.11.
- [Institute 81] M.I. Vuskovic, G. Vitner.
A Study of Interactive Control Scheduling and Economic Assessment for Robotic Systems.
Final Report NASA-CR-168652, JPL-9950-645, Institute for Technoeconomic Systems,
USC., October, 1981.
- [Koopman 82] P Koopman and C Johnson.
IEEE-802 is really a Standard.
Electronic Engineering Times :66, September 13, 1982.
- [Krouse 81] J.K. Krouse.
Automated Factories: the Ultimate Union of CAD and CAM.
Machine Design 53(27):54-60, November, 1981.
- [Merchant 80] M. E. Merchant.
The Factory of the Future- Technological Aspects.
In L. Kops (editor), *Towards the Factory of the Future.* The American Society of
Mechanical Engineers, United Engineering Center, 345 East 47th Street, New York, NY
10017, 1980.

- [Qingsen82] H.Qingsen.
A Linkage Mechanism For The Concentric Gripping of Cylindrical Components.
In 12th International Symposium on Industrial Robots, pages 401-406. Paris, France, June, 1981
- [Shoch 82] John Shoch, Yogen Dalai, David Redell, Ronald Crane.
Evolution of the Ethernet Local Computer Network.
Computer 15(8): 10-27, August, 1982.
- [Syiek 82] David A. Syiek.
User's Manual for Versat
18 August 1982 edition, The Robotics Institute, Carnegie-Mellon University, Pittsburgh, Pennsylvania 15213, 1982.
- [Week 79] M. Week, K. Zenner and Y. Tuchelmann.
New Developments of Data Processing in Computer Controlled Manufacturing Systems.
Society of Manufacturing Engineers Technical Paper (MS79-161) 1979.
- [Wecker80] S.Wecker.
DNA: the Digital Newtwork Architecture.
IEEE Trans. Communications COM-28:510-526, April, 1980.
- [Wright 81] P. K. Wright and A. I Hoker.
A Programmable Die for the Powder Metallurgy Process.
In 9th North American Manufacturing Research Conference at State College, PA (NAMRC IX), pages 65-70. Society of Manufacturing Engineers, Dearbome MI, May, 1981.
- [Wright 82a] P.K. Wright, D.A. Bourne, J.P. Colyer, G.C Schatz and J.AJE. IsasL
A Flexible Manufacturing Cell for Swaging.
In The 14th CIRP Seminar on Flexible Manufacturing Systems. Trondheim, Norway, June, 1982.
- [Wright 82b] P.K. Wright and MJt. Cutkosky.
Achieving Flexibility in Manufacturing Cells.
In to be published in Proceedings ASME Winter Annual Meeting. Phoenix, AZ, November, 1982.