

THE CALIFORNIA EARTHQUAKE OF APRIL 18, 1906

---

REPORT

OF THE

STATE EARTHQUAKE INVESTIGATION COMMISSION

STATE EARTHQUAKE INVESTIGATION COMMISSION

ANDREW C. LAWSON

G. K. GILBERT

H. IT. REID

J. G. BRANNER

A. O. LEUSCHNER

GEORGE DAVIDSON

CHARLES BURKHALTER

W. W. CAMPBELL

# THE CALIFORNIA EARTHQUAKE OF APRIL 18, 1906

---

## REPORT OF THE STATE EARTHQUAKE INVESTIGATION COMMISSION IN TWO VOLUMES AND ATLAS

---

VOLUME I

---

BY

ANDREW C. LAWSON, CHAIRMAN

IN COLLABORATION WITH G. K. GILBERT, H. F. REID, J. C. BRANNER, H. W. FAIRBANKS, H. O. WOOD, J. F. HAYFORD AND A. L. BALDWIN, F. OMORI, A. O. LEUSCHNER, GEORGET DAVIDSON, F. E. MATTHES, R. ANDERSON, G. D. LOUDERBACK, R. S. HOLWAY, A. S. EAKLE, R. CRANDALL, G. F. HOFFMAN, G. A. WARRING, E. HUGHES, F. J. ROGERS, A. BAIRD, AND MANY OTHERS

---

VOLUME I, PART I

---

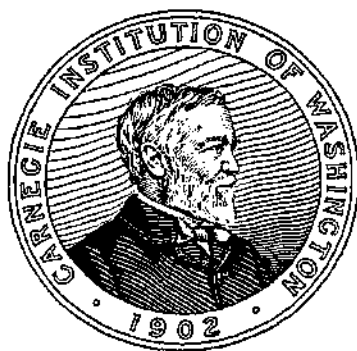

WASHINGTON, D. C.

PUBLISHED BY THE CARNEGIE INSTITUTION OF WASHINGTON

1008

Reprinted 1989

CARNEGIE INSTITUTION OF WASHINGTON

PUBLICATION NO. 87, VOLUME 1, PART I

Printed by  
T. S. Gushing Co. — Berwick & Smith Co.  
Norwood, Mass., U. S. A.

Reproduced offset by  
Sauls Lithograph Company, Inc.  
Washington, D. C.



## FOREWORD.

The reprinting of a sixty-year-old scientific publication, for scientific reasons and in response to a scientific demand, is a rare event indeed. Yet it is precisely for such reasons and in response to such a demand that the Carnegie Institution is presenting once again its Publication 87, *The California Earthquake of April 18, 1906*.

Dr. William W. Rubey, whose lifetime of investigation has influenced the course of modern geophysics so widely and deeply, and whose knowledge of the circumstances surrounding the 1906 earthquake is so unique, has honored this edition with an Introduction that provides in detail the setting in which the 1906 Report was made. It was Dr. Rubey who first sensed and emphasized the special timeliness of the Report today. We believe that geophysicists at large in coming years will share our gratitude to him.

The reprinting has been made possible by a grant of \$15,000 from the Harry Oscar Wood Fund for this purpose. The late Dr. Wood, a noted seismologist and fifteen years a Research Associate of the Institution, was also, most appropriately, a Principal Contributor to this volume.

CARYL P. HASKINS  
President, Carnegie Institution



## INTRODUCTION.

Recommendations to republish this book have come from numerous sources—most influentially, from Dr. Ian Campbell. As State Geologist of the California Division of Mines and Geology, Dr. Campbell was very much aware of the current widespread interest, both popular and academic, in earthquakes and of the demand for this report at libraries throughout California and elsewhere.

In order to understand the place and impact of this report when it appeared and to view it in its historical perspective, it is of interest to review briefly the progress of the science of seismology internationally and in the United States up until the publication of this report in 1908 and 1910.

Earthquakes have always been a source of keen interest—and of terror—to man. In ancient and medieval times, they were variously attributed to volcanic action, to the collapse of rock caverns, to explosions or the rushing of winds underground, and to supernatural causes. With such a range of suggested explanations, it is not surprising that individual earthquakes that caused great devastation and loss of life should have become the object of detailed examination by persons of a curious and sceptical turn of mind and with a bent toward natural philosophy. It is in large part the result of a series of monographic studies by such investigators that seismology emerged as a scientific discipline independent of the unrestrained speculation of earlier writers.

The scientific investigation of earthquakes may be said to have begun with a study, published in 1761 by John Michell of Cambridge University, of the great Lisbon earthquake of 1755. Michell broke free from the interpretations of classical writers of the past and relied solely on the evidence of direct observations. A later milestone in the development of seismology was an investigation of a devastating earthquake at Naples in 1857. In 1862 Robert Mallet, a practical engineer of Dublin and later of London, published a classic monograph on this Neapolitan quake that stood without rival until R. D. Oldham's report in 1899 on the great earthquake of 1897 at Assam, India.

In the years following Mallet's work, seismology advanced significantly as a scientific discipline. Michele de Rossi, Guiseppe Mercalli, and associates in Italy; Francois Forel and Albert Heim in Switzerland; Eduard Seuss in Austria; Montessus de Ballore in San Salvador, France, and Chile; and others in Germany and Russia described individual earthquakes, compiled regional catalogs of their occurrences, and systemized the reporting of earthquake intensities. On May 2, 1877, an earthquake was felt widely throughout central Europe, and in the following year the Swiss Seismological Commission was founded. It survives today as the Swiss Earthquake Service and has served as the model for similar organizations in other countries.

Seismology emerged as a quantitative science in the late 1880's in Japan. On February 22, 1880, Yokohama was rocked by a destructive earthquake, which became the subject of a memoir published by John Milne, a British professor of geology and mining at the Imperial College of Engineering at Tokyo. The memoir was published in 1880 and later that year, on Milne's initiative, a group of British and Japanese teachers formed the Seismological Society of Japan. Designers and builders of the first effective seismographs, Milne and his co-workers investigated individual quakes, the nature of earthquake motion, and the distribution of quakes in space and time. Individuals in the group

performed seismic experiments by means of artificial explosions, compiled comprehensive catalogs of Japanese and distant earthquakes, and drew the first travel time-distance curves. These innovative methods of investigation were the foundations of modern seismology.

The study of earthquakes advanced somewhat more slowly in North America than in Europe and Japan. J. D. Whitney, professor of geology at Harvard University, studied the Owens Valley, California, earthquake of 1872 and reported on it that same year. G. K. Gilbert, of the U. S. Geological Survey, in 1884 described numerous recent fault scarps bordering the Wasatch Mountains and elsewhere in the Great Basin and compared them to similar scarps produced by the Owens Valley quake. In 1889 C. E. Dutton, also of the U. S. Geological Survey, published a monograph on the great Charleston, South Carolina, earthquake of 1886. In a series of articles published from 1872 through 1886, C. G. Bockwood, professor of mathematics at Rutgers and then Princeton University, began the compilation of a catalog of earthquakes in the United States. Bockwood's catalog was continued for the earthquakes of California, Baja California, Oregon, and the Washington Territory from 1887 through 1898 by E. S. Holden, director of the Lick Observatory at Mount Hamilton, California, and two of his colleagues. These annual lists were published as Bulletins of the U. S. Geological Survey.

Holden installed the first seismographs in the United States at Lick Observatory and at the University of California at Berkeley in 1887. Probably the first seismic station in North America to use a seismograph with continuous recording was at Toronto in 1896. By 1901, there were continuous recording stations at Baltimore, Maryland; Philadelphia, Pennsylvania; Victoria, B.C.; and Mexico City, Mexico; and by 1904, there were stations in Washington, D. C.; Cheltenham, Maryland; Sitka, Alaska; and Honolulu, Hawaii.

In 1901 the first conference to establish an international organization of seismologists met at Strasbourg. By the time of the second conference in 1903, twenty countries were represented—double the number that had attended the first. H. F. Reid, the author of Volume II of the present study, represented the United States and was also present at the first meeting of the permanent commission in 1906, which meeting led to the founding of the International Seismological Association. That organization met first at the Hague in 1907 and once again Reid was one of the delegates.\*

On April 18, 1906, shortly after 5:00 a.m., a great earthquake struck San Francisco and a long narrow band of towns, villages, and countryside to the north-northwest and south-southeast. Many buildings were wrecked; hundreds of people were killed; electric power lines and gas mains were broken. Fires broke out and burned wildly for days, utterly out of control because of severed water mains.

The ground had broken open for more than 270 miles along a great fault—the San Andreas rift. The country on the east side of the rift had moved southward relative to the country on the west side of the rift. The greatest displacement had been 21 feet about 30 miles northwest of San Francisco.

Nearly all the scientists in California began immediately to assemble observations on the results of the quake. Professor A. C. Lawson, chairman of the geology department at the University of California, took the first steps that led to Governor George C. Pardee's appointment, three days after the shock, of a State Earthquake Investigation Commission to unify the work of scientific investigations then under way. The members of this

---

\* Gutenberg, Beno, Seismology, in *Geology, 1888-1906*, 50th Anniv. Vol. Geol. Soc. Amer., p. 460, 1941. Much additional information about the history of seismology may be found in:  
 Gfikk<sup>1</sup>, Sir Archibald, *The Founders of Geology*, 2nd ed., Macmillan & Co., 1905. Reprinted, Dover Pubs., Inc., 4th ed., 1962.  
 Adams, F. P., *The Birth and Development of the Geological Sciences*, Dover Pubs., Inc., 1938. Reprinted, 1966, 1954.  
 Davison, Charley, *The Founders of Seismology*. Cambridge Univ. Press, 240 pp., 1927.

Commission were Professor Lawson, Chairman; J. C. Branner, professor of geology at Stanford University; Charles Burckhalter, director of the Chabot Observatory at Oakland; W. W. Campbell, director of Lick Observatory; George Davidson, professor of astronomy at the University of California; G. K. Gilbert, geologist of the U. S. Geological Survey; A. O. Leuschner, professor of astronomy at the University of California; and H. F. Reid, professor of geology at Johns Hopkins University. With the exceptions of Gilbert and Reid, none of the Commission members were then known as students of earthquakes. Nevertheless, they were a distinguished and highly competent group of men. Two of the geologists and two of the astronomers were then members of the National Academy of Sciences and three others subsequently became members of that body.

At its first meeting three days after it was appointed, the Commission organized itself into two committees. One, chaired by Lawson, was to determine surface changes associated with the earthquake and to collect data on the intensity at different places. The second committee, with Leuschner as chairman, was assigned the collection of data on the time of arrival of the earthquake at different places. A few weeks later, when the main features of the quake had become known, a third committee, led by Reid, was appointed to consider problems of the geophysics of the earthquake. The three committees consisted of members of the Commission and 21 other scientists, many of whom—such as Fusakichi Omori, professor of seismology at the Imperial University of Tokyo and one of the greatest seismologists of Japan—were already well-known and many others who later became internationally known as leaders in geology, mathematics, meteorology, and other fields of science.

No State funds were available to defray the expenses of the Commission's investigation, but provision for this purpose was made by the Carnegie Institution of Washington.

The Commission submitted a preliminary report of twenty pages to Governor Pardee on May 31, 1906. In November of the same year, the constitution of the Seismological Society of America was adopted. The first president of the Society was George Davidson, followed in successive years by A. C. Lawson, J. C. Branner, and A. G. McAdie, a member of Committee II of the Earthquake Commission. The secretary of the Society for many years was S. D. Townley, also a member of Committee II.

In preparation of the final report, hundreds of people were interviewed and evidence was collected from every damaged area as well as from records from seismograph stations throughout the world. Lawson spent the winter of 1906-1907 in Washington compiling and editing individual reports from more than twenty collaborating scientists. He prepared an introduction, a section on the geology of the Coast Ranges, and many explanatory statements and summaries to weld the work into one unified report. Volume I, parts I and II, and the accompanying folio atlas were published in 1908 by the Carnegie Institution of Washington. Volume II, *The Mechanics of the Earthquake*, by H. F. Reid, followed in 1910.

The exhaustive report was favorably received on its publication and it continues even today to be very highly regarded by seismologists, geologists, and engineers concerned with earthquake damage to buildings. Volume I, established a model of earthquake investigation and reporting that has been widely followed ever since. Furthermore, it affords an invaluable pictorial record against which tectonic and other geologic changes since 1906 can be compared. Reid's masterly presentation of the elastic rebound theory of earthquakes in Volume II, remains today an apparently satisfactory explanation of one of the more important mechanisms of seismic activity. In all, the report stands as a milestone in the development of an understanding of earthquake mode of action and origin.

WILLIAM W. RXIBBY



## PEEFAOE.

---

The account of the California earthquake of April 18, 1906, contained in this report, exemplifies the spirit of coöperation which pervades the scientific work in our day. Immediately following the great shock not only was the necessity of a scientific inquiry generally perceived, but it was realized that the occasion afforded an exceptional opportunity for adding to our knowledge of earthquakes. The scientific men of the state, each on his own initiative, began the work of assembling observations; the more intelligent citizens became persistent in their inquiries as to the nature of the earthquake, its extent and intensity, and the causes in general of such terrible disasters; and the state, thru its then Governor, George C. Pardee, unified the work of scientific investigation by the appointment of a committee of eight to direct the work. This committee was appointed on April 21, 1906, and became known as the State Earthquake Investigation Commission. On May 31, 1906, the Commission submitted a "Preliminary Report" to the Governor, which was printed and very generally distributed. In this report the details of the organization of the Commission, the program of its work, and the results attained to that date are set forth. But while the Commission acted under the authority of the Governor of the State, no money was provided by the Government for the conduct of its work. The embarrassment arising from this lack of funds was relieved about June 1, 1906, by a subvention from the Carnegie Institution of Washington^ which enabled the Commission to prosecute its work as it had been planned.

About the end of the year 1906, the greater part of the observational data having been collected, the work of sifting, coördinating, compiling, and editing the same devolved upon the Chairman of the Commission. The results of this work, including several special papers by various investigators, are contained in Volume I, parts I and II, of the report and in the twenty-five maps of the accompanying atlas. In this volume especial effort has been made to give due credit to every contributor, whether he be a scientific writer discussing some particular phase of the general problem, or a citizen assisting with local information. In all cases where there is no ascription of authorship the Chairman of the Commission is responsible for the statements made. The multiplicity of contributors has made it inconvenient to duplicate their names in the already lengthy table of contents.

In general, Volume I is a record of observations with quite subordinate discussion of the facts recorded. The effort to condense the record as far as possible has been tempered by the desire to omit no significant fact, so that the record may be as complete as possible for purposes of comparison with similar events which may occur in years to come. In the preparation of this volume the Chairman of the Commission gratefully acknowledges the kind advice and cordial assistance of Messrs. G. K. Gilbert and H. F. Reid. The Commission is also under great obligation to its Secretary, Mr. A. O. Leuschner, for his very efficient services.

Volume II is chiefly a discussion of instrumental records and of the data bearing upon the mechanics of earthquakes, by Mr. H. F. Reid, who also contributes a general

discussion of the theory of the seismograph, which is the first to appear in English. Accompanying this volume are many seismograms of the earthquake, which appear in the general atlas. These seismograms are records of the shock as registered at almost all the seismological stations the world over, and are published at the suggestion of the International Seismological Association for purposes of comparison with one another, to the end that the best recording devices may be generally adopted, and also for comparison with the similar series of seismograms of the Valparaiso earthquake of August 16, 1906, which has been published by the Association.

ANDREW C. LAWSON,

*Chairman State Earthquake Investigation Commission.*

BERKELEY, May 31, 1908.



# CONTENTS.

## PART I.

	<b>PAGE</b>
INTRODUCTION . . . . .	1
GEOLOGY OF THE COAST SYSTEM OF MOUNTAINS . . . . .	5
Definitions . . . . .	5
Geological History . . . . .	6
Structure . . . . .	12
Marginal Features, Granitic Rocks, Folds, Faults . . . . .	12-17
Geomorphic Features . . . . .	19
THE SAN ANDREAS RIFT AS A GEOMORPHIC FEATURE . . . . .	25
General . . . . .	25
Humboldt County. . . . .	26
Point Arena to Fort Ross . . . . .	26
Bodega Head to Bolinas Bay . . . . .	28
General Note, Characteristics of the Rift . . . . .	28-30
Mussel Rock to Pajaro River . . . . .	35
Pajaro River to the North End of the Colorado Desert . . . . .	38
San Jacinto Fault . . . . .	47
Review of Salient Features . . . . .	48
THE EARTH MOVEMENT ON THE FAULT OF APRIL 18, 1906 . . . . .	53
The Fault-trace . . . . .	53
Humboldt County . . . . .	54
Point Arena to Fort Ross . . . . .	59
Fort Ross . . . . .	63
Bodega Head to Tomales Bay . . . . .	65
Tomales Bay to Bolinas Lagoon . . . . .	66
The Fault-trace, Measurements of Throw, Movement Normal to the Fault-plane, Earlier Fault-traces, Cracks, Springs, Interpretation of Bedrock Cracks and Springs, Landslides, Ridging and Shifting of the Tide Lands . . . . .	66-77
The Question of Local Elevation and Depression of Land . . . . .	80
Introductory, About Bolinas Lagoon, About Tomales Bay, Bodega Bay, Summary, Postscript, Second Postscript . . . . .	80-85
Report on a Biological Reconnaissance of Bodega Bay, by William E. Ritter . . . . .	88
Report on a Biological Reconnaissance of Tomales Bay, by Charles A. Kofoid . . . . .	89
Report on a Biological Reconnaissance of the Bolinas Lagoon Region, by Charles A. Kofoid Bolinas Lagoon, The Seacoast Line, The Clam Patch . . . . .	90
Report on a Reconnaissance of Tomales Bay, by R. S. Holway . . . . .	91
Report on an Examination of Plants on Pepper Island, Bolinas Lagoon, by W. L. Jepson . . . . .	91
Mussel Rock to Crystal Springs Lake . . . . .	92
Course of the Fault-trace, Characteristics of the Fault-trace, Offsets on Fences, Pipes, Dams, etc., Exposures of the Fault-plane, Vertical Movement . . . . .	92-103
Crystal Springs Lake to Congress Springs . . . . .	104
Summary Statement, Crystal Springs Lake to Portola, Road from Judge Allen's Southward, Alpine Road, Black Mountain, Page Mill Road, Stevens Creek, South of Congress Springs . . . . .	104-109

	PAGE
Congress Springs to San Juan . . . . .	109
Cracks and Displacements along the Fault-trace, The Tunnel at Wright Station, Engineers' Measurements of Displacement . . . . .	109-111
Geodetic Measurements of Earth-movements . . . . .	114
General Statement . . . . .	114
Extent of New Triangulation . . . . .	114
The Old Triangulation . . . . .	116
Permanent Displacements produced by the Earthquakes of 1868 and 1906 . . . . .	117
Group 1. Northern Part of Primary Triangulation . . . . .	123
Group 2. Southern End of San Francisco Bay . . . . .	126
Group 3. Vicinity of Colma . . . . .	126
Group 4. Tomales Bay . . . . .	127
Group 5. Vicinity of Fort Ross . . . . .	128
Group 6. Point Arena . . . . .	129
Group 7. Southern Part of Primary Triangulation . . . . .	130
Distribution of Earth Movement. Summary . . . . .	132
Discussion of Assumptions . . . . .	135
Changes in Elevation . . . . .	140
Notes on the Comparison of the Faults of the three Earthquakes of Mino-Owari, Formosa, and California, by F. Omori . . . . .	146
Review of Salient Features . . . . .	147
 PROVISION FOR MEASUREMENT OF FUTURE MOVEMENTS ON THE SAN ANDREAS FAULT . . . . .	 152
Relative Positions of the Monuments . . . . .	153
Olema . . . . .	153
Description of Monuments, Leveling Record, Base-line Measures, Level Correction . . . . .	153-155
Crystal Springs Lake . . . . .	156
Description of Stations, Base-line Measures, Relative Elevations, Method of observing Angles, Abstracts of Horizontal Angles . . . . .	156-158
 ISOSEISMALS: DISTRIBUTION OF APPARENT INTENSITY . . . . .	 160
Introductory . . . . .	160
Southern Oregon . . . . .	163
Klamath Mountains and Northeastern California . . . . .	163
Crescent City, Klamath, Peanut, Montague, Gazelle, Sisson, Dunsmuir, Etna Mills, Denny, Big Bar, Papoose, Altruras, Susanville, McArthur, Stella, Redding, Cotton- wood . . . . .	163-165
Humboldt County. . . . .	165
Arcata, Eureka, South of Eureka, Freshwater, Ferndale, Cape Mendocino Light Station, Petrolia, Fortuna, Pepperwood, Briceland, Thorn . . . . .	165-170
Northern Mendocino County. . . . .	170
Shelter Cove to Alder Creek . . . . .	172
Monroe, Hardy, Westport, High-nook, Cleone, Bransconib, Fort Bragg, Caspar, Men- docino, Navarro, Greenwood, Albion and Little River, Bridgeport . . . . .	172-176
Alder Creek to Fort Ross . . . . .	176
Manchester, Point Arena, Gualala, Annals, Stewart's Point, Gualala Valley, Planta- tion House, Timber Cove, Fort Ross . . . . .	176-182
Between the Coast and the Russian River. . . . .	182
Healdsburg to Willets . . . . .	183
Healdsburg, Alexander Valley to Mt. St. Helena, Cracks in the Russian River Flood Plain, Maesaum Slide, Geyserville, Cloverdale, Ukiah, Willets . . . . .	183-188
Clear Lake District . . . . .	188
Hoplund to Lakeport, Upper Lake, Laurel Dell, Lakeport to Lower Lake, Cache Creek Canyon, Vicinity of Upper Lake, Bartlett Springs, Lower Lake, San- hedrin . . . . .	188-190
Fort Ross to Bodega Head. . . . .	190
Duncan's Mills . . . . .	191

CONTENTS.

XV

	PAGE
Tomales Bay to Bolinas Bay . . . . .	191
Along the Fault, Bolinas, Olema, Point Reyes Station, Inverness, Inverness to Point Reyes Light-house, Sunshine Ranch and Vicinity, Bear Valley, Seven Lakes, West of Bolinas, North of Point Reyes Station, Sausalito to Point Reyes Station, Ross to Bolinas, Mill Valley to Bolinas, Distribution, Notes by Other Observers . . . . .	191-198
Between the Coast and Santa Rosa Valley . . . . .	198
Tomales, Dillon's Beach, Tomales to Pefcaluma, Valley Ford, Bloonifield, Bodega . . . . .	198-199
Santa Rosa . . . . .	199
Vicinity of Santa Rosa . . . . .	203
Cotate, Wells East of Santa Rosa, Sebastopol, Altruria, Mark West Springs, Windsor, Guerneville . . . . .	203-206
Santa Rosa Valley to San Francisco Bay. . . . .	206
Petaluina, Lakeville, Petaluma northwai'd up Sonoma Mountain, Petaluma to Sebas- topol, San Rafael, Novato, Sausalito, Mt. Tamalpais, Angel Island Light Station, Yerba Buena Island, Alcatraz Island, Southeast Farallon Island . . . . .	206-209
Sonoma Valley. . . . .	209
Melita, Kenwood, Glen Ellen, Eldridge State Home, Aqua Caliente, Boyes Hot Springs, El Verano, Sonoma, Shellville . . . . .	209-210
Napa Valley to Sacramento Valley . . . . .	210
Napa Valley, Calistoga, St. Helena, Rutherford, Veterans' Home, Napa State Hospital, Napa, Wooden Valley, Pope Valley, Berryessa Valley, Vallejo, Mare Island, Vallejo Junction, St. John's Quicksilver Aline, Benicia . . . . .	210-214
Sacramento Valley . . . . .	214
Red Bluff, Corning, Chico, Willows, Williams, Elk Creek, Colusa, Meridian, Marys- ville, Yuba City, Black's Station, Knight's Landing, Lincoln, Fair Oaks, Sacramento, Gait, Lone, Suisun, Elmira, Vacaville, Esparto, Capay, Guinda, Rumsey, Woodland, Davisville, Maine Prairie, Rio Vista, Collinsville . . . . .	214-217
Northern Sierra Nevada . . . . .	217
Butte County, Plunias County, Sierra County, Nevada County, Placer County, George- town, Nashville, Pino Grande, Drytown, Milton, Railroad Flat, West Point, Gold King Mine, Blanchard, Columbia, Sonora, Tuolumne, Jupiter, Sequoia, Yosemite Valley . . . . .	217-219
Distribution of Appareut Intensity in San Francisco . . . . .	220
Introduction . . . . .	220
Physiography. . . . .	220
Geology. . . . .	221
Destructive Effects and Intensity Scales . . . . .	222
Detailed Description of the Evidence by Localities . . . . .	227
Localities of Lesser Importance affected by Intensity of Grade B. . . . .	231
Phenomena of Especial Interest . . . . .	233
Conclusions . . . . .	241
Addenda . . . . .	241
Subsidence of Made Land, Possible Premonitory Movements, Effect of the Shock near the Beach, Effect of the Shock on the Gas Plant and Pipes, Effect on Certain Street Railways, Deformation of the U. S. Government Buildings, New Post-office, Appraiser's Building, Mint . . . . .	241-245
The San Francisco Peninsula . . . . .	24f
The San Mateo District . . . . .	246
San Carlos, Belmont, San Mateo, Burlingarne, Millbrae, San Bruno . . . . .	2HJ-247
TIH Merced Valley District . . . . .	247
Baden, South San Francisco, The Cemeteries, Landslides, The Coast North of Mussel Rock, Lake Merced . . . . .	217-251
The Area Southwest of the San Andreas Fault . . . . .	251
Difference of Apparent Intensity on the Two Sides of the Fault, Laguna Salada Valley, Cak'nt Valley, San Pedro Point, Moutara Point, Landslides, Pilarcitos Can- yon, Cahill's Ridge, Sawyer's Ridge . . . . .	251-253
Conclusions . . . . .	253
Notes by Other Observers . . . . .	254
San Mateo, Redwood . . . . .	254

## PART II.

	PAGE
Area of the Santa Cruz Quadrangle of the U. S. G. S.	255
Stanford University, Palo Alto, Menlo Park, Fair Oaks, Redwood, East of Palo Alto, Mayfield to Guth Landing, Mountain View, Saratoga to Congress Springs, Stanford University to Portola and Woodside, Page Mill and Alpine Roads, King's Mountain down Purisima Creek, Bear Creek, Half Moon Bay, Purisima and San Gregorio, La Honda, Congress Springs to Boulder Creek, Ben Lomond Mountain to the Coast, Santa Cruz, Road into Scott Valley, Felton, Pescadero to Butano Creek, Pomponio Creek, The Coast from Pigeon Point to Ano Nuevo Bay	255-274
Los Gatos to San Juan.	274
Los Gatos, Lexington, Summit Hotel, Wright Station, Burrell School, Morrell Ranch, About Four Miles South of Wright Station, Skyland, Soquel, Chittenden, San Juan.	274-279
Santa Clara Valley.	279
Newark, Centerville, Mission San Jose, Irvington, Milpitas, Agnews, Alviso to Milpitas, Warm Springs, Milpitas-San Jose Road, Alum Rock Road, Calaveras Valley to Evergreen and Vicinity, Santa Clara, Cemeteries, San Jose, County Road South of San Jose, Los Gatos to Gilroy.	279-288
Hollister to Priest Valley.	288
Hollister, From Hollister to San Benito, Priest Valley.	288-291
Monterey Bay and Eastward.	291
Pacific Grove, Monterey and Del Monte, Castroville to Soquel	291-293
Salinas to San Luis Obispo and Westward.	293
Effect of the Shock on Alluvium, Effect upon Structures, Objects, etc., Prunedale, Salinas, Spreckels and Vicinity, Southward from Salinas, South and West of Salinas Valley.	293-299
San Luis Obispo to San Bernardino	299
Arroyo Grande, Santa Maria, Casmalia, Surf, Lompoc, Point Conception Light-house Station, Santa Barbara, Carpenteria, Saticoy, Hueneme Light-house Station, Calabassas, Santa Monica, Los Angeles, Anaheim, San Bernardino	299-300
Bay of San Francisco to the San Joaquin Valley	300
Berkeley, Oakland, Oakland Cemeteries, Alameda, Southeast of Oakland, Mt. Eden, Decoto, Alvarado, Lick Observatory, Niles, Sunol, Verona, Pleasanton, Livermore, Santa Rita, Dublin, San Ramon, Danville, Walnut Creek, Clayton, Concord, Martinez, Cornwall and Black Diamond, Antioch, Bethany, Byron Hot Springs, Tracy, Lathrop, Stockton, Farmington, Central San Joaquin County, Modesto, Ceres, Oakdale, Westley.	300-316
The Coast Ranges East of the Kift and South of Mt. Hamilton and West Side of the San Joaquin Valley from Westley to Dudley	316
Pacheco Pass Road, Mountain House, San Luis Ranch, Los Baños, Volta, Newman, Crow's Landing, Grayson and Westley, From Westley to Mt. Hamilton, Faicenes, Elkhorn, Emmet Post-office, Panoche Valley, Mendota, Meudota to Coalinga, Coaliuga, Dudley, Cholame, Parkfield, Stone Canyon Coal Mine, Peachtree, Cantua Creek.	316-319
East Side of the San Joaquin Valley South of Modesto and the Adjacent Portions of the Sierra Nevada	319
Merced, Madera, Fresno, Reedley, Visalia, Dinuba, Bakersfield, Isabella	319-320
East of the Sierra Nevada, by George D. Louderback	321
General Note, Round Hole, Peavine Mountain, Reno, Olinghous, Wadsworth, Hazen, Virginia City, Wabuska, Yerington, Fallon, Fairview, Lovelock, Mill City, Unionville, Winnemueca, Hawthorne, Mina, Bodie, Mono Lake, Candelaria, Laws, Tonopah, Goldfield, Eureka, Bishop, Independence, Lone Pine, Keeler	321-324
The Earthquake of April 19, 1906, about 2" 5" p. M.	324
The Earthquake of April 19, 1908, 5 <sup>th</sup> at 8 <sup>th</sup> 30" p. M.	324
Observations by J. A. Reid.	325
Experiments with a Shaking Machine.	326

CONTENTS.

xvii

	PAGE
Review of the Distribution of Apparent Intensity . . . . .	335
General Disposition of the Isoseismals . . . . .	335
Relation of Apparent Intensity to Valleys . . . . .	336
Relation of Apparent Intensity to Known Faults . . . . .	346
DIRECTIONS OF VIBRATORY MOVEMENT. . . . .	351
General Note . . . . .	351
Effects of the Earthquake on Houses in San Mateo and Burlingame . . . . .	354
Criteria . . . . .	354
Damages . . . . .	355
The Effects upon Brick and Stone Buildings, Wooden Buildings, Foundations, Brick Chimneys, Chimneys Other than Brick, Plaster, Dishes, etc., Windows, A Resistant Type of Structure . . . . .	355-358
The Manner and Direction of Movement . . . . .	358
Kinds of Movement, Movement of Houses, Movement of Chimneys, Movement of Dishes, Books, etc., Movement of Furniture, etc., Experience and Testimony of People, Splashing of Liquids, Movement of Various Other Bodies, Predominance of Northwest and Southwest Movements, Cause of Shifting, Relative Intensity of the Main Movement . . . . .	358-364
Intensities . . . . .	365
Conclusions . . . . .	366
Directions in the Tumbales-Boliuas District . . . . .	367
Directions Indicated by Monuments in Cemeteries . . . . .	367
MARINE PHENOMENA . . . . .	369
The Effect of the Earth Movement on the Sea-level, The Shock felt by Ships, Shocks felt at Sea subsequent to April 18, 1906 . . . . .	369-372
NUMBER OF MAXIMA IN THE MAIN SHOCK . . . . .	374
SOUNDS CONNECTED WITH THE EARTHQUAKE . . . . .	377
VISIBLE UNDULATIONS OF THE GROUND . . . . .	380
PATHOGENIC EFFECTS OF THE EARTHQUAKE . . . . .	382
EFFECT OF THE EARTHQUAKE ON ANIMALS . . . . .	382
Horses, Cattle, Cats, Dogs, Chickens, Wild Animals . . . . .	382-383
MINOR GEOLOGICAL EFFECTS OF THE EARTHQUAKE . . . . .	384
Landslides . . . . .	384
Earth-avalanches . . . . .	387
Earth-slumps . . . . .	390
Cape Fortunas Earth-slump, San Pablo Earth-slump . . . . .	390-391
Earth-flows . . . . .	392
Mount Olivet Cemetery, Vicinity of Half Moon Bay, Relation of Earth-flows to Rainfall . . . . .	392-398
Earth-lurches . . . . .	400
Cracks and Fissures . . . . .	401
Effect of the Earthquake upon Underground Waters . . . . .	402
Significance of the Phenomena . . . . .	402
Record of Springs and Wells Affected . . . . .	404
RECORD OF AFTER-SHOCKS . . . . .	410
COMPARISON WITH OTHER SKVERE EARTHQUAKES IN THE SAME REGION . . . . .	434
The Earthquake of 1808 . . . . .	434
The Fault-trace . . . . .	434
The Effect of the Earthquake in San Francisco . . . . .	430
The Distribution of Intensity thruout the State . . . . .	439
Summary . . . . .	447
The Earthquake of 1817 . . . . .	448
The Earthquake of 1807 . . . . .	449

## LIST OF ILLUSTRATIONS.

PLATE	TO FACE PAGE
1. A, Wood Gulch, Hiunboldt County. . . . .	26
2. A, Rift above Shelter Cove, Hurnboldt County. B, Rift on divide between the upper Gualala and coast north of Fort Ross . . . . .	26
3. A, Rift above Shelter Cove. B, Northeast of Shelter Cove. Rift in middle ground. C and I), Looking up Garcia River along Rift . . . . .	26
4. Characteristic Rift features southeast of Fort Ross . . . . .	26
5. Characteristic Rift features near Fort Ross . . . . .	28
6. A, Looking down Tomales Bay from near Olema. B, Looking down Bolinas Lagoon Bay toward the Golden Gate . . . . .	32
7. A, Looking north in Bolinas-Tomales Valley. B, Fault-sag and side-hill ridge near Bondi-etti's ranch . . . . .	32
8. A, Fault-sag 6 miles south of Olema. B, Side-hill ridge 4 miles south of Olema . . . . .	34
9. A, Side-hill ridge south of Olema. B, Rift topography, with pond, south of Olema . . . . .	34
10. A, Rift topography, with pond, near Bondi-etti's ranch. B, Fault-trace near same . . . . .	34
11. A, Fault-sag 2 miles south of Olema. B, Fault-sag 3 miles south of Olema . . . . .	34
12. A, Looking northwest along Rift. B, Great landslide at Mussel Rock, where Rift enters Coast from the Pacific . . . . .	36
13. Characteristic ponds along Rift southeast of Mussel Rock. . . . .	36
14. Features of Rift between Mussel Rock and San Andreas Lake. . . . .	36
15. Geomorphologic and Geologic Map of San Francisco Peninsula . . . . .	38
16. A, Rift valley between San Andreas and Crystal Springs. B, Rift valley 5 miles west of Stanford University. . . . .	38
17. A, Rift followed by Pajaro River at Chittenden. Dislocated bridge supported by false work. B, Rift a mile southeast of Chittenden. . . . .	38
18. A, Rift 3 miles southeast of Chittenden. B, Ponds along Rift near San Benito . . . . .	40
19. A, Rift south of Dry Lake Valley, San Benito County. B, Ancient scarp on line of Rift west of Parkfield, Cholame Valley. . . . .	40
20. Branch of Rift 2 miles southeast of Parkfield, Cholame Valley. . . . .	40
21. Rift, Carissa Plain. . . . .	40
22. A, Cuddy Valley from head of San Kmedio Canyon. B, Old Fault-scarp in Rift . . . . .	42
23. A, Rift from Emerson's place, near Pattiway. B, Looking east along Rift from Gorman Station . . . . .	42
24. A, Pond and scarp in Rift east of Gorman Station. B, Lower Lake Elizabeth in Rift . . . . .	42
25. A, Rift between Lake Elizabeth and Palmdale. B, Rift scarp west of Palmdale . . . . .	42
28. A, Sink between 2 scarps of Rift south of Palmdale. B, Pond in Rift 2 miles west of Big Rock Creek, Mojave Desert . . . . .	44
27. A, Fault-scarp in Rift, Mojave Desert west of Big Rock Creek. B, Ridge in Rift near head of Swartout Valley. . . . .	44
2X. A, Rift across mountain crest west of Swartout Valley. North slope of San Gabriel Range. B, Lone Pine Canyon across lower end of Cajon Canyon . . . . .	44
29. A, Rift from Cajon Pass, showing double scarp. B, Double fault-scarp in Rift north of Highland, at base of San Bernardino Range. . . . .	44
30. A, Looking across Borego Valley toward south end of San Jacinto fault-scarp. H, Nearer view, upper end of Borego Valley. . . . .	47
31. A, Fault-scarp passing thru saddle, at head of Wood Gulch. B, Auxiliary fault-trace following old warp in saddle between Wood Gulch and Hiunboldt Creek. C Telegraph Hill along fault-trace. I), Looking north-northwest along main fault. . . . .	51
ii). A, Kooky .4re;mi eliff 7d feet, hi^h on north side of Alder Creek. B, Fault passing under bridge over Alder Creek. C, Barn of E. E. Fitch, north of Manchester. D, East-west fence 2.7 mile north of Manchester offset by fault . . . . .	51

## LIST OF ILLUSTRATIONS.

XIX

PLATE	TO FACE PAGE
33. A, East-west fence near saddle between Garcia River and Brush Creek. B, Small railway trestle, Little North Fork, Gualala River. C and D, Buckled track, Little North Fork, Gualala River . . . . .	6 0
34. A, Fault-trace in redwood forest near Fort Ross. B, Dislocation in fence near Fort Ross . . . . .	64
35. A, Accentuation of old scarp by new fault 1.5 miles north of Fort Ross. B, Fault-trace on grass-covered slope near Fort Ross . . . . .	6 4
36. A, Offset of fence a mile east of Fort Ross. B, Fault-trace and dislocated fence near Fort Ross. C, Roadway offset 12 feet above Fort Ross. D, Accentuation of old fault-scarp by new fault, near Fort Ross . . . . .	6 4
37. A, Offset stream trench by fault and ponding water by fault-scarp. B, Fault-trace a mile northwest of Bolina Lagoon. . . . .	.64
38. A, Fault-trace in old depression, Doda's ranch a mile southeast of Fort Ross. B, Fault-trace marked by scarp 3± feet high on west side. C, Fault-trace across tidal flats of Tomales Bay near its mouth. 1), Fault-trace between garden and house, Skinner's ranch near Olema . . . . .	.66
39. A, Branch of fault-trace in north part of Bolinas. B, Branch of fault-trace near Bondietti's ranch. . . . .	.66
40. A, The fault-trace a mile northwest of Olema. B, Fault-trace west of Olema . . . . .	60
41. A, On Pepper Island. B, Looking north from hill west of Woodville . . . . .	66
42. A, Sag followed by fault-trace north of Strain ranch. B, Looking southeast from point near Shafter's ranch, Olema. . . . .	.68
43. A, Fault-trace south of Olema. B, Looking southeast across hill-top a mile south of Olema . . . . .	68
44. Fault-trace northwest of Olema . . . . .	.68
45. A, Fault-trace on Papermill delta. B, Branch of fault-trace in "Second Valley," at Inverness . . . . .	68
46. A, Fault-trace on Papermill delta. B, Fault-trace at Skinner place, near Olema . . . . .	72
47. A, Branch of fault-trace on "north mesa," at Inverness. B, Road offset by fault . . . . .	72
48. A, Fault-trace a mile northwest of Olema. B, Fault-trace near Bondietti's ranch . . . . .	7 2
49. A, Fence offset by fault. B, Cracks in tidal mud near head of Bolinas Lagoon . . . . .	7 2
50. A, Road embankment broken by shaking of soft ground beneath. B, Faults in road embankment southwest of Point Reyes Station . . . . .	76
51. A, Roadside crack between Inverness and Point Reyes P.O. B, Roadside crack southeast of Inverness. . . . .	.76
52. A, Group of earthquake cracks southwest of head Pine Gulch Creek. B, Earthquake cracks in Bolinas at edge of an earthquake sag. . . . .	76
53. A, Fault-scarp on earthquake crack. B, Landslide from road-cliff west of Inverness . . . . .	76
54. A, Landslide 4 miles northwest of Bolinas Lagoon. B, Ridged mud-plain a mile from Inverness. . . . .	78
55. A, Landslide 2.5 miles northwest of Bolinas Lagoon. B, South part of Inverness shoal, at low tide, April 28, 1906. . . . .	78
56. A, Ridges on tidal flat of Tomales Bay, 1 mile south of Inverness. B, Bedrock shoal near Bolinas, with clam patch near outer edge. C, Clam patch near Bolinas. D, Salicornia in Limantour Bay. . . . .	78
57. A, Martinelli's pier at Inverness. B, Bailey's pier at Inverness. . . . .	80
58. Bailey's pier at Inverness. . . . .	80
59. A, Rupture of 30-inch water-pipe by fault, northwest of San Andreas Lake. B, Thrust of 10-inch water-pipe by fault, northwest of San Andreas Lake. . . . .	100
60. A, Offset in 30-inch water-pipe by fault, northwest of San Andreas Lake. B, Collapse of same. C, Offset of 6.5 feet in fence, northwest of San Andreas Lake. D, Offset of 6.5 feet in fence between San Andreas and Crystal Springs Lake . . . . .	100
61. A, Fault-trace where it passes into San Andreas Lake. B, Offset fence near Crystal Springs Lake. . . . .	100
62. A, Exposure of slicken-sided fault-plane near Crystal Springs Lake. B, Offset of road by main fault near Searsville reservoir . . . . .	100
63. A, Offset of Alpine road 5 miles west of Stanford University. B, Offset of 8 feet in fence on Folger ranch, near Woodville . . . . .	108
64. A, Reservoir in saddle south of Saratoga traversed by main fault. B, Offset in fence at Morrell's ranch, above tunnel at Wrijht station. . . . .	110

## LIST OF ILLUSTRATIONS.

PLATE	TO FACE PAGE
65. A, Offset in road near Wright. B, Steel bridge over Pajaro River, near Chittenden	110
66. A, Wrecked stores, Ferndale, Humboldt County. B, Wrecked buildings, Fort Bragg	172
67. A, Odd Fellows' Hall, Fort Bragg. Looking east. B, U. O. Co. mill, Fort Bragg	172
68. A, Point Arena. Brick house destroyed; wooden houses little affected. B, Wreck of suspended flume across Garcia River. C, Collapsed wagon bridge over Gualala River	176
69. A, Sound redwood tree snapped off 42 feet from top. Near Fort Ross. B, Redwood tree snapped off, above Fort Ross. C, Uprooted tree about half mile west of Garcia River. D, Bridge over South Fork, Gualala River.	176
70. A, Bell and Kinslow building, Healdsburg. B, Odd Fellows' Hall, Healdsburg	183
71. A, Buckled water-pipe, Inverness. B, Wrecked water-tank, near Inverness	194
72. A, Ruin of Inverness Reservoir. B, Wrecked water-tank, near Inverness	194
73. A, Cold-storage plant, Petaluma. B, Buckner Hotel, Willets. C, Corner Main and Washington Streets, Petaluma	198
74. Santa Rosa	200
75. Santa Rosa	200
76. Santa Rosa	200
77. Santa Rosa	200
78. City Hall, Santa Rosa	202
79. A, House moved 7 feet by collapse of underpinning, Santa Rosa. B, House lurched to north, Santa Rosa. C, Wrecked dwelling, Santa Rosa. D, Wreck of brick structure, Santa Rosa	202
80. A and B, Cemeteries, Santa Rosa. C and D, Cemeteries, Sebastopol	202
81. A, East side of main street, Sebastopol. B, Wrecked buildings, Sebastopol. C, Stone house, 15 miles southeast of Tomales. D, Wrecked church, Tomales	202
82. City Hall, San Francisco	228
83. A, Near view of wreck at City Hall, San Francisco. B, Cattle killed by falling masonry, San Francisco	228
84. Observatory, Strawberry Hill, Golden Gate Park, San Francisco	230
85. Observatory, Strawberry Hill, Golden Gate Park, San Francisco	230
86. Restaurant at Children's Playground, Golden Gate Park, San Francisco	230
87. A, O'Farrell Street, San Francisco, after earthquake and before fire. B, Geary Street, between Filmore and Steiner Streets, San Francisco	230
88. A, Frame building on west side of Eleventh Avenue, just south of California Street, San Francisco. B, Slip of a fill on Union Street, just west of Steiner Street, San Francisco. C, Russ Street, between Folsom and Howard Streets, San Francisco. D, Moss Street, between Folsom and Howard Streets, San Francisco	236
89. A, Columbia Street just south of Folsom Street, San Francisco. Slumping, depression, and furrowing of block pavement. B, Bryant Street, near Fourth Street, San Francisco. Flexure of heavily ballasted car tracks in block pavement. C, Sixth Street, near Howard. Sidewalk held up by piling foundation of building. D, Looking along Dore Street, from Bryant toward Brannan	236
ML A, Dore Street from Brannan toward Bryant. B, Dore Street, near Brannan. C, Eighteenth Street, just east of Shotwell. D, Southwest corner Portola and Waller Streets	236
HI. Ninth Street, between Bryant and Brannan	237
92. A, St. Dominic's Church, Bush and Steiner Streets. B, Looking south on Howard Street from near Seventeenth Street. Compressional flexure of car rails	238
83. A, East side of Howard Street, between Seventeenth and Eighteenth Streets. B, Valentia Street, near Eighteenth	240
94. A, View along Nineteenth Street, from Guerrero Street. B, San Francisco Post-office, Mission and Seventh Streets	240
95. A, WTKLawn Cemetery, south of San Francisco. B, Hills of Eternity Cemetery, south of San Francisco	250
M. A, Holy Cross Cemetery Station, south of San Francisco. B, Holy Cross Cemetery, south of San Francisco	250
II7. A, Overthrown monument, Holy Cross Cemetery. B, Brick building and high chimney left standing. South San Francisco. C, Roadbed and rails of electric railway on marsh west of Saw Bruno. D, Roadbed and rails of electric railway between Baden and San Bruno	250



LIST OF ILLUSTRATIONS.

xxi

PLATE	TO FACE	PAGE
98. A, Wreck of 1-story brick railway warehouse, San Mateo. B, Brick stable, San Mateo . . .		250
99. A, Wreck of 2-story brick building, San Mateo. B, Wreck of 2-story brick building, San Mateo . . .		256
100. A, Trestle carrying a 30-inch water pipe across Frawley Gulch demolished by shock. B, Statue of Agassis: thrown from its niche above arches, Stanford University . . .		256
101. A, Destruction of arcade at Sacred Heart Convent, Menlo Park. B, Gateway of Campus, Stanford University . . .		250
102. A, Geology Building, Stanford University. B, Panorama of destruction, Stanford University. Memorial chapel in middle right . . .		250
103. A, Ruin of Memorial Arch, Stanford University. B, Front view of Memorial Church, Stanford University. . .		258
104. A, Wreck of the Library Building, Stanford University. B, Wreck of the Gymnasium Building, Stanford University. . .		258
105. A, Wrecked arches, Geology Building, Stanford University. B, Arches that moved on their supporting columns, Stanford University. . .		258
106. A, Tree overthrown by earthquake, west of Searsville Lake. B, Live oak uprooted by earthquake, west of Seai'sville Lake . . .		258
107. A, Shortening of railroad track between Los Gatos and Santa Cruz. B, Morrell house, near Wright Station. . .		276
108. A, Agnew's Insane Asylum. North end of female wards. B, Agnew's Insane Asylum. North side. C, Phelan Building, San Jose. D, Hall of Records, San Jose . . .		282
109. A, High-school, San Jose. B, Hotel Vendome, Annex, San Jose. . .		282
110. A, Post-office, San Jose. B, Box factory, corner Fifth and Julian Streets, San Jose . . .		284
111. San Jose. . . . .		284
112. San Jose. . . . .		284
113. San Jose. . . . .		284
114. A and B, Gilroy. C, Hollister. Demolition of brick building shown in D. D, Hollister. Same building as shown in C, before earthquake. . .		289
115. A, Alvarado. Wreck of molasses tanks, Alameda Sugar Company. B, Salinas. Wreck of corner store . . .		294
116. A, Near Watsonville. Concrete pier of bridge shattered. B, Salinas. Wreck of store. C, Salinas. Walls of building thrown out. D, Moss Landing. Wreck of wooden warehouse. . . . .		296
117. A, Spreckels Sugar Mill, near Salinas. Entire building buckled. B, Spreckels Sugar Mill . . .		296
118. A, Berkeley. Institute for Deaf, Dumb, and Blind. South wing. B, North wing . . .		300
119. A, Berkeley. Barker Block. Shattuck Avenue and Dwight Way. B, Berkeley. High-school. . . . .		300
120. A, Oakland. Central Bank Building. B, Smokestack of power plant, Oakland Traction Company. . . . .		302
121. A, Oakland. Flax Works, Union and Third streets. B, Prescott School, Ninth and Campbell Streets. . . . .		302
122. A, Oakland. First Baptist Church, Telegraph Avenue. B, Fourteenth Street, between Washington and Broadway. . . . .		302
123. A, Bridge over Salinas River, 4 miles south of Salinas. B, Los Banos Hotel. C, Los Banos Bank. D, Coalinga . . . . .		316
124. A, Maacama earth-avalanche. B, Close view. C, Earth-avalanche in granite on road near Half Moon Bay. D, Deer Creek, Santa Cruz Mountains. Earth-avalanche from Grissly Peak. . . . .		388
125. A, Deer Creek, Santa Cruz Mountains. B, Scarp of landslide, near Cantua . . . . .		389
126. A, Earth-avalanche on side of canyon, near Chittenden. B, Earth-avalanche in sandstone, near Half Moon Bay. . . . .		390
127. Earth-slumps at Cape Fortunas, Humboldt, County. . . . .		390
128. Earth-slumps east of San Pablo. . . . .		392
129. A, Earth-slump north of Toniales, carrying railway roadbed with it. B, Earth-slump north-east of Tomales, at Freeman's. C, Earth-slump at Mussel Rock. D, Scarp of Mussel Rock earth-slump . . . . .		392
130. Earth-flow at Mount Olivet Cemetery. . . . .		392

PLATE	TO FACE PAGE
131. A, Earth-flow, Mount Olivet Cemetery, at base of San Bruno scarp. B, Earth-flow in hills east of Half Moon Bay. . . . .	392
13*2. A, Earth-flow in hills east of Half Moon Bay. B, Earth-flow in small valley near Half Moon Bay. . . . .	394
14-i. A, Earth-flow illustrating floor of cavity from which flow came. B, Earth-flow 4 miles east of Half Moon Bay. . . . .	394
14. A, Moss Landing. House, tree, and fence moved 12 feet by lurching of ground toward Salinas River. B, Moss Landing. Lurching of ground toward Salinas River carried piles from beneath bridge timbers, causing it to collapse . . . . .	400
15j. A, Moss Landing. Lurching of ground toward Salinas River, to left, carried piles from beneath bridge timbers and caused bridge to collapse. B, Moss Landing. Deformation of surface due to lurching of ground toward Salinas River . . . . .	400
15lj. A, Lurching of the ground toward Salinas River and consequent collapse, near Spreckels. B, Detail of view shown in A. . . . .	400
17. A, Lurching of ground toward Salinas River, with consequent collapse. B, Destruction of road due to lurching of ground toward Salinas River near Spreckels . . . . .	400
138. Eel River, near Ferndale . . . . .	402
139. A, Russian River, west of Windsor. B, Russian River. Crack in flood plain parallel to river. C, Fissures in alluvium, Tevis ranch, near Alma. D, Upheaval of bottom of artificial lake, Tevis ranch, near Alma . . . . .	402
140. A, Secondary cracks in alluvium near Milpitas. B, Secondary cracks in alluvium on banks of Coyote Creek. . . . .	402
141. A, Concentric cracks in ground around an old alkaline spring, north of Livermore. B, Secondary crack in alluvial floodplain on Pajaro River . . . . .	402
142. A, Craterlets in sand near marsh east of Bodega Bay. B, Craterlets along fault-trace on sand spit at mouth of Tomales Bay . . . . .	404
143. A, Craterlets in fields near Milpitas. B, Craterlets near Watsonville . . . . .	404
144. A, Flour mill, Haywards. B, Edmouson's warehouse, Haywards. C, Flour mill and warehouse, Haywards. D, Pierce's house, Haywards. E, Haywards. Wreck of buildings by earthquake of 1851. F, Court-house, San Leandro . . . . .	434
145. Effects of the earthquake of 1851 in San Francisco . . . . .	434
146. Map of San Francisco, showing distribution and degree of damage caused by the earthquake of 1851 in relation to the made land. . . . .	436

## LIST OF MAPS AND SEISMOGRAMS IN ACCOMPANYING ATLAS.

## MAPS.

- No.
1. Geomorphic map of California and Nevada with parts of Oregon and Idaho, showing' diastrophic character of relief, the steep descent from the subcontinental shelf to floor of the Pacific, and the more important faults of California.
  2. Map of a part of the coast of California, etc.
  3. Detail map of a typical part of San Andreas Rift near Fort Ross, Sonoma County, California, showing geomorphic features and trace of fault.
  4. Map of region about San Francisco Bay, etc.
  5. Map of part of San Francisco, etc.
  6. Map of California, Mount Pinos Quadrangle.
  7. Map of California, Tejon Quadrangle.
  8. Map of California, Palmdale Quadrangle, of the U. S. Geological Survey, showing San Andreas Rift.
  9. Map of California, Rock Creek Quadrangle.
  10. Map of California, San Antonio Quadrangle.
  11. Map of California, Hesperia Quadrangle.
  12. Map of California, San Bernardino Quadrangle.
  18. Map of California, Redlands Quadrangle.
  14. Map of California, San Geronio Quadrangle.
  15. Map of California, San Jacinto Quadrangle.
  16. Map of the City of Santa Rosa, Sonoma County, California, showing parts destroyed by earthquake of April 18, 1906, and fire consequent thereto.
  17. Geological map of the City of San Francisco.
  18. Geological profiles with corresponding intensity curves across the City of San Francisco.
  19. Map showing distribution of apparent intensity of the earthquake shock.
  20. Map of the City of San Francisco, showing streets and burnt area, 1906.
  21. Map of California, San Mateo Quadrangle, of the U. S. Geological Survey, showing distribution of apparent intensity, known faults, and routes examined.
  22. Map of California, Santa Cruz Quadrangle, of the U. S. Geological Survey, showing distribution of apparent intensity, known faults, routes examined, and numbered localities referred to in the text.
  28. Map of California and Nevada, showing distribution of apparent intensity in region affected by the earthquake of April 18, 1906.
  24. Map of Coast Range region of Middle California, showing distribution of earth movement on April 18, 1906, as revealed by displacement of triangulation stations of the Coast and Geodetic Survey, as determined by resurvey, 1900-1907.
  25. Distribution of the earth movement on April 18, 1900, and in 1808, as revealed by displacement of triangulation stations of the Coast and Geodetic Survey, as determined by resurvey in 1900-1907.

## SEISMOGRAMS.

TABLE NII.

1. Toronto, Canada; Victoria, Canada; Baltimore, Md.; Coimbra, Portugal; San Fernando, Spain ; Pilar, Argentina; Calcutta, India; Kew, England; Paisley, Scotland; Ponta Delgada, Azores; Bidston, Phigland ; Edinburgh, Scotland ; Cape of Good Hope, Africa; Cairo, Egypt.
2. Irkutsk, Siberia (Milne instrument); Island of Mauritius; Perth, Australia; Honolulu, H. I.; Wellington, N. Z.; Kodaikanal, India; Bombay, India; Taschkent, Turkestan (Hepsold-Zöllner instrument) ; Kremsmunster, Austria.
2. a. — Irkutsk, Siberia (Repsold-Zöllner instrument); Ucele, Belgium.
8. Berkeley, Cal.; San Jose, Cal.; Yonntville, Cal.; Cleveland, Ohio; Oakland, Cal.; Los Gatus, Cal.; Alameda, Cal.; Mt. Hamilton, Cal.; Carson City, Nevada.
4. Manila, P. I.; Potsdam, Germany (Von Rebeur-Puschwitz instrument).
6. Munich, Germany; Potsdam, Germany (Wieehert }>eiiduluiii) ; Kobe, Japan.
- tj. Florence, Italy.

## SHEET NO.

7. Shide, England (heavy horizontal pendulum); Porto D' Ischia, Italy; Grande Seutinella, Italy; Pavia, Italy.
8. Washington, D. C.; Cheltenham, Md.; Albany, N. Y.; Porto Rico, W. I.
9. Vienna, Austria; Upsala, Sweden; Tacubaya, D. F. Mex.
10. Jurjew, Russia; Ottawa, Canada.
11. Sitka, Alaska; Tokyo, Japan; Jena, Germany.
12. Göttingen, Germany; Shide, England (Milne instrument, open scale); Messina, Italy.
13. Sofia, Bulgaria; Krakau, Austria; Irkutsk, Siberia (Bosch-Omori instrument); Taschkent, Turkestan (Bosch-Omori instrument); Catania, Italy.
14. Rocca di Papa, Italy; Granada, Spain; Strassburg, Germany.
15. Zi-ka-wei, Shanghai, China; Osaka, Japan; Taihoku, Formosa; Batavia, Java; Sarajevo, Bosnia; Calamate, Greece; Bombay, India (Coloba horizontal pendulum).

## THE CALIPOKNIA EAKTHQUAKE OF APEIL 18, 1906.

---

### INTRODUCTION.

On the morning of April 18, 1906, the coastal region of Middle California was shaken by an earthquake of unusual severity. The time of the shock and its duration varied slightly in different localities, depending upon their position with reference to the seat of the disturbance in the earth's crust; but in general the time of the occurrence may be stated to be 5<sup>h</sup> 12<sup>m</sup> A. M. Pacific standard time, or the time of the meridian of longitude 120° west of Greenwich; and the sensible duration of the shock was about one minute.

The shock was violent in the region about the Bay of San Francisco, and with few exceptions inspired all who felt it with alarm and consternation. In the cities many people were injured or killed, and in some cases persons became mentally deranged, as a result of the disasters which immediately ensued from the commotion of the earth. The manifestations of the earthquake were numerous and varied. It resulted in the general awakening of all people asleep, and many were thrown from their beds. In the zone of maximum disturbance persons who were awake and attending to their affairs were in many cases thrown to the ground. Many persons heard rumbling sounds immediately before feeling the shock. Some who were in the fields report having seen the violent swaying of trees so that their top branches seemed to touch the ground, and others saw the passage of undulations of the soil. Several cases are reported in which persons suffered from nausea as a result of the swaying of the ground. Many cattle were thrown to the ground, and in some instances horses with riders in the saddle were similarly thrown. Animals in general seem to have been affected with terror.

In the inanimate world the most common and characteristic effects were the rattling of windows, the swaying of doors, and the rocking and shaking of houses. Pendant fixtures were caused to swing to and fro or in more or less elliptical orbits. Pendulum clocks were stopt. Furniture and other loose objects in rooms were suddenly displaced. Brick chimneys fell very generally. Buildings were in many instances partially or completely wrecked; others were shifted on their foundations without being otherwise seriously damaged. Water or milk in vessels was very commonly caused to slop over or to be wholly thrown from the vessel. Many water-tanks were thrown to the ground. Springs were affected either temporarily or permanently, some being diminished, others increased in flow. Landslides were caused on steep slopes, and on the bottom lands of the streams the soft alluvium was in many places caused to crack and to lurch, producing often very considerable deformations of the surface. This deformation of the soil was an important cause of damage and wreckage of buildings situated in such tracts. Railway tracks were buckled and broken. In timbered areas in the zone of maximum disturbance many large trees were thrown to the ground and in some cases they were snapt off above the ground.

The most disastrous of the effects of the earthquake were the breaking out of fires and, at the same time, the destruction of the pipe systems which supplied the water necessary to combat them. Such fires caused the destruction of a large portion of San Francisco, as all the world knows; and they also intensified the calamity due to the earthquake at Santa Rosa and Fort Bragg. The degree of intensity with which the earthquake made itself felt by these various manifestations diminished with the distance from the seat of disturbance, and at the more remote points near the limits of its sensibility it was perceived only by a feeble vibration of buildings during a brief period.

The area over which the shock was perceptible to the senses extends from Coos Bay, Oregon, on the north, to Los Angeles on the south, a distance of about 730 miles; and easterly as far as Winnemucca, Nevada, a distance of about 300 miles from the coast. The territory thus affected has an extent, inland from the coast, of probably 175,000 square miles. If we assume that the sea-bottom to the west of the coast was similarly affected, which is very probably true, the total area which was caused to vibrate to such an extent as to be perceptible to the senses was 372,700 square miles. Beyond the limits at which the vibrations were sufficiently sharp to appeal to the senses, earth waves were propagated entirely around the globe and were recorded instrumentally at all the more important seismological stations in civilized countries.

The various manifestations of the earthquake above cited, including the cracking and deformation of the soil and incoherent surface formations, were the results of the earth jar, or commotion in the earth's crust. The cause of the earthquake, as will be more fully set forth in the body of this report, was the sudden rupture of the earth's crust along a line or lines extending from the vicinity of Point Delgada to a point in San Benito County near San Juan; a distance, in a nearly straight course, of about 270 miles. For a distance of 190 miles from Point Arena to San Juan, the fissure formed by this rupture is known to be practically continuous. Beyond Point Arena it passes out to sea, so that its continuity with the similar crack near Point Delgada is open to doubt; and the latter may possibly be an independent, tho associated, rupture parallel to the main one south of Point Arena. It is most probable, however, that there is but one continuous rupture. The course of this fissure for the 190 miles thru which it has been followed is nearly straight, with a bearing of from N. 30° to 40° W., but with a slight general curvature, the concavity being toward the northeast, and minor local curvatures. The fissure for the extent indicated follows an old line of seismic disturbance which extends thru California from Humboldt County to San Benito County, and thence southerly obliquely across the Coast Ranges thru the Tejon Pass and the Cajon Pass into the Colorado Desert. This line is marked by features due to former earth movements and will be referred to in a general way as a *rift*, the term being adopted from the usage for analogous features in Palestine and Africa.<sup>1</sup> To distinguish it from other rifts of similar origin, it will be referred to more specifically as the San Andreas Rift, the name being taken from the San Andreas Valley on the peninsula of San Francisco, where it exhibits a strongly pronounced character and where its diastrophic origin was first recognized in literature.

The plane or zone on which the rupture took place is, so far as can be determined from a study of the surface phenomena, nearly vertical; and upon this vertical plane there is a horizontal displacement of the earth's crust or at least of its upper part. The displacement was such as to cause the country to the southwest of the rift to move relatively to the country on the northeast side of that rift. The differential displacement in a horizontal direction was probably not less than 15 feet for the upper part of the Rift; in many places it measured over 15 feet, and in some places as much as 21 feet.

<sup>1</sup> H. y. Oograph. Sue. v. 1. iv, 4, 1894. The Great Rift Valley, by J. W. Gregory, London, 1896.

This differential displacement of the earth's crust along the plane of rupture constitutes & *fault*, and will be so referred to in the text of the report. It is named the San Andreas fault. The intersection of the fault plane or narrow zone with the surface of the ground is manifested by cracks, heaved sod, scarps, etc., and these manifestation<sup>^</sup> are designated the *fault-trace*. As a result of this fault, all the fences, roads, railways, bridges, tunnels, dams, pipes, and other structures which cross its path were dislocated. All property lines and other survey lines which were intersected by it were offset. Inasmuch as the movement of the earth which caused the fault was not confined to its immediate vicinity, but was distributed over a considerable belt of country on either side of the trace of the rupture, the latitudes and longitudes of a large portion of the Coast Ranges of California were changed, and the triangles established by the Coast and Geodetic Survey in its triangulation of the region were distorted.

In addition to the horizontal displacement there was, particularly toward the northern end of the fault, a vertical displacement probably nowhere exceeding 2 to 3 feet, whereby the country to the southwest was raised relatively to that to the northeast. In many places, however, particularly toward the southern end of the fault, no vertical displacement can be detected; and there is some indication that, if there was vertical displacement in this region, it was the reverse of that observed in the northern portion of the fault. This rupture of the earth's crust gave rise to certain manifestations at the surface which resemble those described above as a result of the vibratory commotion of the earth, due to the sudden displacement. The cracking and rending of the surface along the line of the fault is a direct expression of the rupture and displacement which originated the earthquake, whereas the cracks, fissures, and lurching of the soft bottom lands and the landslide cracks on the hillsides, whether near the fault line or remote from it, are referable to the oscillation of the crust. The two classes of phenomena must, therefore, be discriminated, particularly<sup>^</sup> as there has been a tendency on the part of some observers to class the secondary phenomena with the primary and interpret the former as indicative of fault lines in the earth's crust, when in reality they are merely superficial phenomena\*

While the shock was perceptible to the senses to the extent above indicated in California, Nevada, and Oregon, the distribution of the higher grades of intensity was remarkably linear and was definitely related to the fault line, and to the general trend of the coast of California. This may be brought out in a preliminary way by stating that a zone of destructive effects extends parallel to the Rift from Humboldt Bay, in Humboldt County, to the vicinity of King City in Monterey County, a distance of 350 miles. If we take the throw of brick chimneys and allied phenomena as indicating the limits of what may be called destructive effects, the width of this zone may be fairly approximated at about 70 miles, or about 35 miles on either side of the fault, or its prolongation where no actual fault is observable at the surface. The length of this zone of destruction is thus five times greater than its width, and the total area within which the shock was sufficiently severe to throw brick chimneys may be placed at something over 25,000 square miles; it being assumed that the severity to the southwest of the fault, beneath the waters of the Pacific, was equal to that on the land. If the fault near Point Delgada be regarded as distinct from that extending from Point Arena southeasterly, then the total area of these high intensities would be considerably larger in the direction of the Pacific.

Within this outer limit of destructive effects the intensity increased toward the fault. But proximity to the fault was not the only factor determining the degree of intensity. The soft, more or less incoherent, and water-saturated alluvial formations of the valley-bottoms were much more severely shaken than the rocky slopes of the intervening ridges, and the structures upon them were consequently more commonly and more completely wrecked. It is not understood by this excessive damage on the valley-

bottoms that the vibratory movement due to the passage of the earth-wave was characterized by greater energy than where it traversed elastic rocks; but that this energy was manifested in a form of movement more destructive to structures upon the surface. The intensity of the shock upon the valley-bottoms, as inferred from damage, seemed abnormally high. In terms of energy it was probably not abnormal. It thus became necessary to discriminate between *apparent intensity* and *real intensity*. Inasmuch as we have to deal primarily with observable effects and record these as a basis for inference, it has been found convenient to use the term "apparent intensity" in a technical sense thruout the report; and all the grades of intensity specified, even when the qualification "apparent" is omitted because of the wearisomeness of its reiteration, are grades of "apparent intensity" arrived at by applying literally the criteria of the Rossi-Forel scale.



## GEOLOGY OF THE COAST SYSTEM OF MOUNTAINS.

---

### DEFINITIONS.

In common with many other mountainous tracts the world over, the Coast System has limits which are difficult of precise definition. The criteria which serve to discriminate one tract from another are various and have different values in different cases. Any attempt at precise definition must be more or less arbitrary. An outline of the extent and subdivisions of the system will, however, be presented in summary fashion.

On the north the Coast System extends to the northern end of Humboldt County, and in that county and in southern Trinity County the last typical ridge is South Fork Mountain. This is a remarkably linear ridge beginning near the coast and extending with a northwest-southeast course to the vicinity of North Yallo Bally Mountain. Beyond South Fork Mountain to the northeast lie the Klamath Mountains, a group more nearly allied in the history of its uplift and in its constituent rocks to the Sierra Nevada than to the Coast Range. On the south the Coast System is sometimes regarded as ending in Santa Barbara County; and the mountains of Southern California; thence east-southeast and south to the Mexican boundary, are regarded as a distinct system, being viewed as a northerly prolongation of the orographic axis of the peninsula of Lower California. The chief consideration favoring this distinction is the change in trend of the mountain ridges, which becomes apparent just north of the Santa Barbara Channel. Other facts favor this discrimination, such as the prevailing absence of the Franciscan formations in the mountains of southern California and the greater abundance of granitic rocks; but more especially the greater incisiveness of the structural lines, indicating, on the whole, more intense orogenic action. But these considerations are largely offset by the unmistakable continuity of the tectonic lines of the northern ranges into the mountains of southern California, and by the fact that the movements to which their larger features are due date from the close of the Tertiary. It would seem, therefore, that there is sufficient unity of character in these coastal mountains, in spite of their change of trend, to warrant their being classed as the Coast System from South Fork Mountain south to the Mexican boundary and beyond. That term may be used in a comprehensive sense, significant of the genetic and structural unity which runs thru them.

It will nevertheless be very convenient to recognize three subdivisions of the Coast System thus outlined. The first of these subdivisions extends from South Fork Mountain on the north to the Valley of the Cuyama River on the south, and may, in accordance with popular usage, be referred to simply as the Coast Ranges, the term "system" being used only when it is intended to express the more comprehensive view. The second subdivision is a broad chain extending from Santa Barbara County to the far side of the Colorado desert with a general trend of west northwest-east southeast, and including the San Rafael, Santa Ynez, Santa Susannah, Santa Monica, San Gabriel, and San Bernardino Ranges, and also, perhaps, the Chocolate Range. This chain is sometimes referred to as the Sierra Madre, tho the full application of the term in popular usage is not clear. The third subdivision embraces the mountainous country south and southeast of the valley of Southern California, the principal ranges of which are the Santa Ana and the San Jacinto. These have the northwest-southeast trend of the Coast Ranges and, in accordance with the suggestion of some of the earlier writers on Californian geology, may be referred to as the Peninsular chain.

## GEOLOGICAL HISTORY.

The Coast Ranges of California have had a long and varied geological history. Their structure is complex and the sequence of formations differs at different points. Several of the more important groups of sedimentary rocks contain, so far as known, but few fossils or none at all. Only in recent years have the topographic maps necessary for an adequate study of the stratigraphy and structure of the region become available, and then only for limited areas. Nevertheless the general outlines of the geology of the Coast Ranges are known, and in some of the localities which have been topographically mapped, a considerable body of detailed information is at hand.

The oldest sedimentary rocks of the Coast Ranges are of unknown age. They comprise impure and somewhat magnesian limestone, quartzites, and various crystalline schists. The limestones are usually in the form of coarse marble varying in color from dark gray to white and containing frequently some graphite and less commonly lime silicate. The quartzites are thoroly indurated, as a rule, sometimes to the extent of being vitreous, and usually show well-marked stratification. The schists have as yet been little studied, and no adequate observations upon their character in detail have been put on record. They are known, however, to comprise both micaceous and hornblendic varieties.

These marbles, quartzites, and crystalline schists are known only in more or less fragmentary form, associated with considerable bodies of granitic rocks which have invaded them as batholiths. The most common occurrence of the marbles, quartzites, and schists is in the form of limited belts and isolated patches embedded in the granitic rocks, or in limited areas flanking the margins of the batholiths, and showing evidence of contact metamorphism. It is evident in most cases, and is probably generally true, that the granite of the Coast Ranges is of later date than the metamorphic sedimentary rocks associated with them. While the age of these pregranitic sedimentary formations is at present unknown, the age of the granite is suggested by its seeming identity with the granite of the Sierra Nevada. The latter is a vast batholith known to be intrusive in Paleozoic and Mesozoic strata as late as the Upper Jurassic. This granite has been followed thru the Sierra Nevada to Tehachapi and Tejon Pass, where the range curves sharply around and passes into the Coast Ranges. Passing northerly thru the Coast Ranges, granite identical in character with that of the Sierra Nevada, and carrying identical inclusions of older sedimentary rocks, is traceable in more or less extensive areas from the upper reaches of the Cuyama River to Bodega Head on the coast north of the Golden Gate. It thus seems probable that the granite of the Coast Ranges, like that of the Sierra Nevada, is of late Jurassic or post-Jurassic age. The granitic rocks of the Coast Ranges, together with the pregranitic rocks into which they are irruptive, constitute a complex which is thus the probable analogue of the Bedrock Complex of the Sierra Nevada.

This Coast Range Complex was subjected to vigorous erosion and then submerged to serve as the sea floor upon which the series of rocks known as the Franciscan was deposited. This series consists for the most part of medium coarse, dark gray or greenish-gray sandstone, strongly indurated, with subordinate shales and conglomerates. Intercalated with these sandstones are important horizons of foraminiferal limestone and radiolarian chert and admixtures of volcanic rocks, chiefly basaltic in character. In the vicinity of the Bay of San Francisco, where the series is best known, it falls into seven stratigraphic divisions. These are in ascending order:

- (1) A group of arkose sandstones with some conglomerates and shales reposing unconformably upon the Montara granite and with an aggregate thickness of about 800 feet.
- (2) A formation of light-gray, very compact and fine-textured foraminiferal limestone ranging in thickness from about 60 to possibly a few hundred feet.

- (3) Sandstones aggregating 2,000 feet in thickness.
- (4) A formation of radiolarian cherts from 100 to 900 feet.
- (5) Sandstone, 1,000 feet.
- (6) Radiolarian cherts, 500 feet.
- (7) Sandstone, 1,400 feet.

In this sequence of sedimentary strata, particularly toward its upper part, there are intercalated lavas at various horizons.

After their accumulation, but before the next higher series of rocks was deposited upon them, the Franciscan strata were invaded by intrusive rocks at points so numerous and so widespread thruout the Coast Ranges that these intrusive bodies constitute one of their most characteristic associations, in contrast to the series which succeed them. The intrusive rocks are of two general types. One is a highly magnesian rock, usually a peridotite, but with facies of pyroxenite and gabbro, the peridotite being generally almost completely serpentized. The other is a basaltic rock grading into diabase and having in many of its occurrences the peculiar structure characteristic of the spheroidal basalts. In addition to the spheroidal structure on the gross scale, it is in some cases variolitic. Associated with both of these intrusives are areas, generally of limited extent and sporadic distribution, of glaucophane and other crystalline schists, which appear, where they have been most thoroly studied, to be the result of a peculiar kind of contact metamorphism.

The stratigraphic composition of the Franciscan series indicates an interesting to-and-fro migration of the shore line of that time, probably due to a vertical oscillation of the continental margin. The basal group of sandstones, shales, and conglomerates is clearly a terrigenous deposit laid down in proximity to the margin of the continental area from which the sediments were derived. The next succeeding formation, the foraminiferal limestone, on the contrary, is nonterrigenous. Its character as nearly pure carbonate of lime, except for the flinty lenses and nodules it contains, and the abundance of foraminifera, indicates that the sea-bottom over the present position of the San Francisco Peninsula was too remote from the shore to receive an admixture of sand or clay. That is to say, the conditions which favored the deposition of the limestone were inaugurated by a withdrawal of the shore line from the position which it occupied during the deposition of the underlying sandstones. And this lateral migration of the shore was doubtless the result of a sinking of the coast.

Above the foraminiferal limestone sandstones again occur, indicating a return of the shore to about its former position, doubtless due to an uplift of the sea-bottom and coast. These sandstones are in turn followed by a nonterrigenous formation of radiolarian cherts. These are for the most part flinty rocks containing abundant remains of radiolaria, marine organisms which secrete a siliceous test instead of a calcareous one, as in the case of the foraminifera. They contain no admixture of sand, and the shaly partings which separate the layers of chert are very doubtfully referable to land waste. Here again the sea bottom must have been depressed and the shore line caused to withdraw. These radiolarian cherts are followed again by sandstones, and these by a second formation of radiolarian cherts, the former as before indicating uplift of the sea-bottom and the latter depression. The last movement in Franciscan time was uplift, indicated by the sandstones, which rest upon the second horizon of radiolarian cherts and which constitute the topmost formation of the Franciscan series.

The age of the Franciscan is not positively known. Certain general considerations, however, contribute data upon which a tentative judgment as to this question may be based. Stratigraphically, the Franciscan lies upon the eroded surface of the Coast Range granites, the correlation of which with the post-Jurassic granites of the Sierra Nevada has been suggested. If such correlation be adopted, the age of the Franciscan must be

post-Jurassic. On the other hand, the Franciscan is clearly pre-Knoxville; and the Knoxville has usually been regarded as the local base of the Cretaceous. Fossils are scarce in the Franciscan, but such fragmentary forms as have thus far been found point to a Cretaceous age. It would seem not improbable/ therefore, that the Franciscan represents a pre-Knoxville division of the Cretaceous, which has not as yet been recognized in the geological scale. The question, however, requires further investigation before a final decision can be reached.

After the accumulation of the Franciscan strata as thus characterized, and perhaps in connection with the invasion of the series by peridotitic and basaltic intrusives, the region was folded and broken, and elevated within the zone of erosion. The elevatory movement was probably quite general. The Franciscan, while subjected to general denudation, was probably nowhere stripped down to the underlying basal complex before it was submerged to receive the next succeeding sedimentary strata. These comprize the Knoxville formation, consisting wholly of shales and sandstones with quite subordinate layers and lenses of limestone, all in very regular and rather thin strata, significant of deposition in a shallow basin under fluctuating conditions of transportation. The Knoxville varies in volume from a few hundred to several thousand feet and is widely distributed over the Coast Ranges. It is succeeded in the vicinity of the Bay of San Francisco, and to a less marked degree in other parts of the Coast Ranges, by a formation of coarse conglomerate known as the Oakland conglomerate. This conglomerate attains a thickness of over 1,000 feet in places and follows the Knoxville shales in apparently conformable sequence. The change in the character of the deposits from shales to coarse conglomerates, without any interruption in the continuity of sedimentation, suggests an orogenic disturbance of the margins of the basin within which the Knoxville beds were accumulating, whereby the grades of the streams were greatly accentuated and the degradation of the continental region correspondingly accelerated.

The Oakland Conglomerate, or, where that is missing, the Knoxville shale, is directly followed by a formation of thick bedded sandstones and shales known as the Chico formation. It has a thickness in places of many thousands of feet. The entire volume of strata, from the base of the Knoxville to the top of the Chico, is usually referred to as the Shasta-Chico Series, the Shasta comprizing the Knoxville and Oakland formations, together with certain other paleontological subdivisions not here particularly mentioned. The series is remarkable for its great volume. In the northern Coast Ranges to the west of the Sacramento Valley, the thickness of the sedimentary section, comprizing practically only sandstones and shales, is as much as 29,000 feet. This vast accumulation of strata clearly signifies the development of a great geosyncline, or depression of the sea-bottom in that region in which deposition kept pace with subsidence thruout this portion of Cretaceous time. The Shasto-Chico series is usually regarded as comprizing the whole of the California Cretaceous, but the considerations cited above in regard to the Franciscan indicate that the latter may perhaps be included in the lower Cretaceous section of this region.

The movements which brought the Mesozoic to a close and inaugurated the Tertiary in the Coast Range region were not those of violent orogenic deformation such as characterize this period of geological time in many other parts of the world; but were rather of the nature of a partial elevation of the region, with quite gentle deformation, resulting in a notable restriction of the basin of deposition. The earliest Eocene strata show no marked structural discordance with the Chico. It is nevertheless very probable that a notable unconformity exists, since the abundant and characteristic Cretaceous fauna disappeared and was supplanted by an almost totally distinct assemblage of life forms. The Eocene of the California Coast Ranges falls into two paleontologically distinct groups which have been classed together as the Karquines series. The lower of these

comprizes about 2,000 feet of sandstones, portions of which are green sands, together with some shales. These make up the Martinez group. Its distribution, so far as known at present, is quite limited and is confined to the middle Coast Ranges on their eastern side, between Clear Lake and Mount Diablo. The upper division of the Karquines is known as the Tejon group, and comprizes also about 2,000 feet of sandstones, often somewhat ferruginous and weathering reddish, but very strongly cemented. The Tejon strata are apparently conformable upon the Martinez, but the sharp contrast in the faunal contents of the two groups suggests rather widespread physiographic changes at the close of the Martinez which may be regarded as indicative of unconformity. The Tejon strata are much more widely distributed than the Martinez, a fact which suggests the enlargement of the Karquines basin of deposition by subsidence of the coast during the progress of Eocene time.

The next succeeding group of rocks, belonging to the Oligocene division of the Tertiary, has been named the San Lorenzo Formation.<sup>1</sup> It is known in Santa Cruz County, where it attains a thickness of 2,300 feet, made up chiefly of gray shales and fine sandstones. Its stratigraphic relations to the Tejon are not yet known, but its fauna is said by Arnold to contain many species which appear to be closely related to Tejon forms. It may thus be considered as following the Tejon conformably. It is in certain sections known to be unconformable beneath the oldest formation of the Miocene, known as the Vaqueros Sandstone, indicating that after the deposition of the San Lorenzo formation, the region of the Coast Ranges was disturbed and uplifted into the zone of erosion; and the following facts regarding the transgression of the Miocene Sea indicate that this uplift was a very extensive one. Such an uplift in time immediately preceding the Miocene is further indicative of a much closer relationship between the San Lorenzo and the Tejon than between the former and the Monterey.

Miocene time in the Coast Range region was characterized by a progressive subsidence with oscillations of the coast. The Miocene sea gradually transgressed the continental margin from the southwest, and as it did so spread a formation of arkose sands and conglomerates over the greater part of the southern Coast Ranges. This was followed, as the water deepened with progressive subsidence, by a remarkable deposit of bituminous shales. These shales are usually whitish or cream-colored, tho often of a purplish or other dark tint, and may be either of a soft chalky consistency, or opaline, or hard and flinty. It is thruout an essentially siliceous formation and is largely diatomaceous in character, tho more or less admixt with volcanic pumiceous ash. In some portions the ash is a prominent constituent, and in San Luis Obispo County there is a deposit aggregating about 1,000 feet in thickness of well-stratified volcanic tuff and agglomerate. In San Mateo County there are basalts which were erupted at this period. Interstratified with these siliceous shales, thin beds of more or less ferruginous and somewhat magnesian limestones are by no means uncommon. They are, however, lenticular or non-persistent, and are of a very compact texture and usually nonfossiliferous. There are also in some places thin but persistent beds of a peculiar, very hard, fine-grained, light-colored sandstone intercalated with the shales. In the southern portion of the Coast Ranges the bituminous shales accumulated to a thickness of several thousand feet, but in the middle Coast Ranges, in the vicinity of the Bay of San Francisco, the Miocene sea was characterized by an oscillatory or to-and-fro migration of its eastern shore line, due to alternate uplift and subsidence of the coast, quite analogous to that described for the Franciscan period. This gave rise to an alternation of shallow water in which sandstones were deposited, and deep water in which siliceous ooze accumulated with but little admixture of terrigenous material. We have thus in the territory between Mount Diablo and the Bay of San Francisco an alternation of four formations of bituminous

---

<sup>1</sup> Arnold, U. S. G. S. Professional Paper No. 47, p. 16.

shale with five formations of sandstone, the latter being at the bottom and top of the series. The series is known as the Monterey series, and its various members have distinctive formational names. While the oscillation of the coast so clearly recorded in the strata near the Bay of San Francisco is not apparent in the southern Coast Ranges, it is by no means certain that they were not affected in a similar way. The vertical movement involved was not great, and such a movement might have extended over the deeper portions of the area of deposition in Monterey time without effecting a sufficient change in the depth of the water to alter the character of the sediments. The Monterey sea apparently did not, even at the time of its maximum transgression, extend far over the region of the northern Coast Ranges, and a line drawn from Tehachapi to Cape Mendocino would probably represent the general position of the shore at the close of Monterey time.

At the close of the Miocene, the Coast Range region was disturbed by orogenic movements and uplifted into the zone of erosion. It was then depressed irregularly so as to give rise to local basins of sedimentation in which accumulated great thicknesses of Pliocene beds, particularly about the Bay of San Francisco and southward. The oldest of these Pliocene formations is the San Pablo, which lies unconformably upon the Monterey strata. This is essentially a sandstone formation with a thickness of from 1,000 to 2,000 feet. It occurs on both sides of the Coast Ranges from the vicinity of the Bay of San Francisco southward and appears to have been laid down in two basins, separated by a barrier corresponding to the general axis of the present Coast Ranges. The formation on the east side of the range is characterized by a notable admixture of dark andesitic ash, which gives the unweathered exposures of the sandstones a distinctly blue color. This formation has a fauna of over 100 species, of which more than 40 per cent are living forms. This fact, and the unconformable superposition of the formation upon the Monterey, are warrant for placing it in the Pliocene. On the west side of the Coast Ranges, the San Pablo is best known in San Luis Obispo and Santa Barbara Counties, and is there free from volcanic admixtures, though the basal beds are very commonly characterized by the presence of asphaltum, which cements the sand together and constitutes the well-known bituminous rock of the region. This asphaltum appears to have originated in part as a seepage from the upturned bituminous shale of the Monterey along the shores of the San Pablo sea, and molluscan remains of San Pablo age are often embedded in it.

Succeeding the San Pablo, but nowhere, so far as the writer is aware, reposing directly upon it, is the Merced series. The sediments composing this series were laid down in rather acute geosynclinal troughs, resulting from orogenic deformation of the coast in middle Pliocene time. Three of these troughs are known. The most northerly is that now occupied by the Valley of the lower Eel River in Humboldt County; the second is largely occupied by the Santa Rosa Valley in Sonoma County; the third is on the Peninsula of San Francisco, extending thence south to the coast of Santa Cruz County. The Merced strata in the Valley of the lower Eel River, and the typical Merced section near San Francisco, show each a thickness of something over a mile. In Sonoma County the marine Merced beds grade eastward into fluvial conglomerates, admixed with volcanic ashes. The maximum thickness is about 3,500 feet. The lower part of the series is here characterized by a considerable volume of white volcanic pumiceous tuffs, which thin out rapidly to the westward. These were in part laid down directly on a land surface, burying forests of huge sequoia, whole trees being now completely silicified.<sup>1</sup> On the coast of Santa Cruz County, the series is represented by strata of lower stratigraphic horizons than nearer San Francisco, these lower beds having been called the Purissima formation, although the sedimentation was continuous with that of the Merced. The

<sup>1</sup> For description of the Merced beds of Sonoma County and the underlying pumiceous tuff, a paper by V. C. Osmont, Bull. Dept. Geol., Univ. Cal., vol. 4, No. 3, should be consulted.

lower horizon of the beds on the Santa Cruz Coast, as compared with the beds nearer San Francisco, indicates a transgression of the Merced sea from the south. The upper portion of the Merced section contains so large a proportion of molluscan remains of existing species that it has been regarded by Arnold as Pleistocene rather than Pliocene.

The accumulation of the Merced series to the great thickness above indicated in middle and northern California proves local depressions of the coast of over a mile below sea level in later Pliocene time. Similar orogenic deformation was in progress at the same time on the eastern side of the barrier corresponding to the then axis of the Coast Ranges. These movements gave rise to great troughs from which the sea was excluded, but which were occupied by fresh water, and filled with sediments equal in volume to those of the marine troughs to the west of the barrier. The greater part of these fresh-water beds are comprized in the Orindan formation, which may be the equivalent of the Cache Lake beds of the Clear Lake district \* and of the Paso Robles in the southern Coast Ranges. They have an extensive distribution on the eastern side of the Coast Ranges, and in the vicinity of the Bay of San Francisco there intervenes between the base of the Orindan and the San Pablo a formation of white pumiceous tuff entirely similar to that at the base of the Merced series in Sonoma County, but containing here fresh-water fossils. This tuff attains a maximum thickness of about 1,000 feet and is known as the Pinole tuff. Thruout the Orindan there are occasional intercalated strata of volcanic tuff of moderate thickness. The Orindan lacustrine period was brought to a close in the region of the middle Coast Ranges by volcanic eruptions which resulted in extensive flows of lava and showers of ashes. Upon these lavas lake basins were later established and some hundreds of feet of fresh-water deposits (Siestan formation) accumulated in them, which were in turn buried by other lavas.

The accumulation of the Merced marine beds and the corresponding lacustrine and volcanic rocks was brought to a close by an acute and widespread deformation regarded as part of the general mountain-making movements which ushered in the Pleistocene in western North America. As a result of these movements, the Merced and Orindan basins were folded and faulted, and the basement upon which their contained strata had been laid down was lifted in part from a position over a mile below sea-level to one far above sea-level. The Pliocene formations were brought within the zone of active erosion and the evolution of the present geomorphic features of the Coast Ranges was inaugurated. When the degradation of the folded Orindan strata was well advanced, a lake basin was established across the edges of these strata and in it accumulated the various fresh-water beds and volcanic lavas and tuffs comprizing the Campan series. At a time within the Pleistocene when the geomorphic evolution of the coast had been well advanced to its present condition, the coastal belt was deprest 1,000 to 2,000 feet lower than it is at present, and then uplifted in stages marked by marine terraces along many parts of the coast. Since this there have been oscillations of the region about the Bay of San Francisco, the net result of which has been a depression allowing the sea to invade the valleylands and thus make the magnificent harbor to which San Francisco owes its existence.

In the foregoing sketch of the formations of the Coast Ranges and their historical significance, it is desired to emphasize particularly the remarkable series of subsidences and uplifts which have affected the coastal region from the beginning of the Franciscan to the present. This record of oscillation is in marked contrast to the comparative stability of the Sierra Nevada. Except for a marginal strip of its foot-hill slopes, the region of the present Sierra Nevada has not been submerged beneath the sea. During the geological ages in which the Coast Range region has been repeatedly deprest to receive marine sediments, the sum of the maximal sections of which amounts to 65,000 feet of strata, the western edge of the Sierra Nevada region has probably never been

---

<sup>1</sup> Described by G. F. Becker, U. S. G. S. Monograph x m, pp. 219-221, 238-242.

depress over 1,000 feet. The geological record for the latter region is in terms of degradation rather than of deposition; and such deposits as have here accumulated are referable wholly to fluvial, lacustral, and volcanic agencies. It is thus apparent that from the point of view of the stability of the earth's crust, the Coast Range region has been very much more mobile than the Sierra Nevada. The long comparative stability of the latter was, it is true, interrupted at the close of the Tertiary by a very notable uplift, whereby it took the form of a tilted orographic block of great size and remarkable unity; but this does not detract from the force of the contrast. The difference in behavior with respect to crustal stability makes the Coast Ranges a totally distinct and different geological province from the Sierra Nevada.

Between these two strongly contrasted provinces lies the great valley of California, one of the very notable geomorphic features of the continent. This valley is but one of a long series of similar depressions which lie along the western border of the North American continent, between the coastal uplands and the western edge of the continental plateau. In the north it has its probable analogues in Hecate Strait, the Gulf of Georgia, Puget Sound, the Willamette Valley, the Ashland Valley, and the depression between the Sierra Nevada and the Klamath Mountains. On the south we see its analogues in the Colorado Desert, the Gulf of California, and in the valley which lies between the southern border of the central plateau of Mexico and the Sierra Madre del Sur. In the Californian region we must interpret the axial line of this depression as a tectonic hinge, upon which the mobile coastal region has swung in a vertical sense upon the edge of the interior plateau, here represented by the Sierra Nevada. Whether this tectonic hinge is a more or less flexible zone upon which movement has taken place without rupture, or whether it represents a zone of dislocation, is not clear; but that differential movement has taken place along the valley line is one of the salient facts in the geological history of California.

#### STRUCTURE.

A detailed account of the structure of the Coast System would involve a discrimination between features referable to the different orogenic movements which have affected the region at various periods of its history. Owing to this succession of movements, new structures have been superimposed upon older structures, or upon remnants of older structures, so often that the resultant effect is extremely complicated and not only difficult to unravel but difficult to state or describe in any simple way. In this summary review of the subject, no such detailed discrimination will be attempted. The only effort will be to call attention to the salient features, which are for the most part referable to the orogenic movements of later Tertiary and post-Tertiary time.

*Marginal Features.* — In a consideration of the structural features of the Coast System, its marginal lines on the east and west first claim attention. The eastern slope of the Coast Ranges rises from the floor of the Great Valley much more abruptly in general than does the western slope of the Sierra Nevada from the same valley floor. Turner<sup>1</sup> has suggested that the Great Valley east of the Coast Ranges is determined by a fault. There is some warrant for this view and it is certainly true in part. The very precipitous mountain front which rises from the valley at its southern end is without doubt a degraded fault-scarp, tho whether or not this fault or a series of similar faults can be followed along the edge of the mountains to their northern end is questionable. It is, however, safe to say that the eastern margin of the Coast Ranges represents a line of acute deformation, with the probability of that deformation having taken the form of faults in certain places. No one has yet made a sufficiently careful study of the question to make a more precise statement possible. In general, this line of acute deformation is not

<sup>1</sup> Am. Geologist, vol. xm, p. 248.



straight, but is curved, with the concavity toward the northeast. Between the southern end of the valley and the vicinity of Coalinga its course is about N. 35° W. From Coalinga, where there is an offset or jog in the general trend north to Tracy, the course is about N. 30° W. From Tracy to Suisun there is a marked westerly embayment in the Coast Ranges which is probably due, in part at least, to the depression of the region about the Bay of San Francisco. From Suisun northward to the vicinity of Red Bluff the general course of the margin of the Coast Ranges is north and south. At Tejon Pass the eastern margin of the Coast System receives the abutment of the southern end of the Sierra Nevada; thence southward, with a course swinging more easterly, it determines the southwest limit of the Mojave Desert.

On the seaward side the Coast System is usually regarded as being limited by the shore line. The precipitous coast rising to elevations of from 2,000 to 5,000 feet, extending from Cape Mendocino to Point Conception, and the popular notion that mountain ranges are confined to the land areas of the earth, are justification for this view. But in a more comprehensive view, embracing all inequalities of the earth's surface both above and below the sea-level, the western margin of the mountainous area, the familiar portions of which we call the Coast System, will have to be placed farther seaward. Off the coast of California the sea-bottom slopes down to the 3,000-foot submarine contour at a moderate angle and then plunges steeply to depths of over 12,000 feet. Beyond the foot of this steep slope the sea-bottom has very flat gradients and the 15,000-foot contour is far out to sea. From the Oregon line to Point Conception the 3,000-foot submarine contour, or the brink of the steep slope, lies off shore at a distance of from 15 to 35 miles; but at Cape Mendocino and at the Bay of Monterey this line is found much closer in. South of Point Conception this steep slope has the same general trend as to the north. That is to say, it shows no embayment in its course corresponding to that at the Santa Barbara channel and southward. This is particularly true of the course of the 6,000, 9,000, and 12,000-foot contours. The slope is by no means uniform for its entire length. From Point Arena to the latitude of the Golden Gate the grade is notably steep from the 3,000 foot to the 9,000-foot contour. This is also true off Point Conception. From the latter point southeastward the steep portion of the slope is from the 6,000-foot to the 12,000-foot contour; and the same statement holds for the slope off San Simeon Bay. In general, the steepest profile lies between the 6,000 and the 9,000-foot line.

This steep drop from the subcontinental platform to the broad floor of the Pacific must be regarded as the geomorphic expression of a rather acute deformation of the earth's crust, and those portions of the slope where the contours are crowded together, as for example between Point Arena and the latitude of the Golden Gate, off San Simeon Bay, off Point Conception, and off the platform of the Channel Islands, can scarcely be interpreted as other than fault-scarps. The slopes at the localities mentioned are quite comparable to the great fault-scarp which forms the eastern front of the Sierra Nevada. At the base of the slope off the Channel Island platform, the recent dredging operations of the *Albatross* brought up from a depth of 12,000 feet numerous fragments of rock similar to the bituminous shale of the Monterey series of the southern Coast Range. With this rock was found much asphaltum. This indicates that at the base of the slope there are talus accumulations of so recent a date that they have not yet been buried by oceanic sediments.

This line of acute deformation of the crust off the entire length of the coast of California can not be ignored in any consideration of the orographic features of the region. The slope referred to is doubtless devoid of those sculptural features characteristic of mountains within the zone of erosion, and which we are too apt to look upon as essential, but it constitutes nevertheless a notable mountain front rising from the floor of the Pacific. It is the natural western boundary of the mountainous tract which we call the

Coast System. The course of this mountain from the Pacific to the Atlantic, with convexity to the Pacific, observable in the Coast Ranges, in the Great Valley of California, and in the Sierra Nevada. This convexity toward the Pacific is, it may be observed in passing, characteristic of the dominant tectonic lines about the border of that great ocean. It is very marked in the Aleutian belt, in Kuriles, in the Japanese Isles, in the festoon extending from Formosa thru the Philippines, the Moluccas, and Java to Sumatra, which is convex to both the Pacific and the Indian Oceans; and in the chain including the Salomon Islands, the New Hebrides, and New Zealand. It is also apparent in the trend of the Sierra Madre Occidental and Sierra Madre del Sur of Mexico, and in the course of the Andes thru Colombia, Ecuador, and Peru.

Having indicated the east and west boundaries of the Coast System as their dominant structural lines, we may now consider those features which pertain to the internal structure of the mountain tract. Here we must first take note of the coast line. The coastal slope of California characteristically rises abruptly from sea level to elevations of from 2,000 to 5,000 feet within a short distance from shore, from Cape Mendocino to Point Conception, with certain notable breaks in its continuity which are susceptible of special explanation. If along the shore line at the base of this abrupt slope we draw straight lines which are tangent to the headlands or chords to the minor embayments of the coast, these lines fall into two fairly constant orientations and clearly bring out the fact that the shore line has in reality a zigzag course, due apparently to the alternate control of two systems of structural lines, one of which is between N. 37° W. and N. 40° W., and the other between N. 10° W. and N. 15° W., thus intersecting at an angle of about 26°. Under this scheme of discrimination of the orientation of different portions of the coast line, the bearings of the following divisions may be thus listed:

LOCALITIES.	BEARING OF MEAN LINE.	DISTANCE IN GEOGRAPHICAL MILES.
Cape Mendocino to Punta Gorda . . . . .	N. 12° W.	14
Punta Gorda to Shelter Cove . . . . .	N. 40° W.	25
Shelter Cove to Point Arena . . . . .	N. 10° W.	64
Point Arena to Golden Gate, thru Tomales Bay.	N. 40* W.	90
Golden Gate to Pigeon Point » . . . . .	N. 15° W.	40
Pigeon Point toward Santa Cruz . . . . .	N. 40° W.	21
Point Pinos to Point Sur . . . . .	N. 13° W.	19
Point Sur to Port Hartford . . . . .	N. 37° W.	89
Port Hartford to Point Conception . . . . .	N. 6° W.	44

Now it is difficult to regard any considerable portion of the abrupt coastal slope of California between Cape Mendocino and Point Conception as other than a more or less degraded fault-scarp. If this view be accepted, it is clear that the trend of the coast and its geomorphic profile have been determined by two systems of faults meeting or intersecting at an angle of about 26° on their strike. Making some allowance for cliff recession, the base of both systems of scarps must lie some little distance off shore and be buried by the notable embankment of littoral sediments which conceals the true profile of the submarine rock surface.

Of the two systems of faults thus recognized as controlling the trend of the coast, one, viz. that which bears N. 37° W. to N. 40° W., conforms, as will be shown later, more or less closely with the prevailing structural lines, such as faults, folds, and belts of igneous rock found in the Coast Ranges; while the more meridional system is not a prominent feature of the Coast Ranges. It follows that since the mean trend of the California coast lies between the bearings of the two fault systems, the tectonic lines of the Coast System, if followed northwesterly, eventually emerge upon the coast. This obliquity of the

tectonic lines of the Coast System to the general trend of the coast has long been familiar to California geologists and has been particularly noted by Fairbanks,<sup>1</sup> but the probable explanation of it has not heretofore been set forth.

The coastal scarp is interrupted at a number of points and in a variety of ways. The most notable and interesting interruption is that of the Bay of Monterey. This is not only an embayment of the coast, but is a depression in the Coast Ranges extending down over their submarine portion to the 12,000-foot contour below sea-level. It brings the 3,000-foot submarine contour well inside the general line of the coast. This submarine valley has been regarded by some writers as a submerged valley of subaerial erosion, but there is little warrant for this view and much that conflicts with it. The valley of the Bay of Monterey, subaerial and submarine, is a synclinal trough the axis of which is approximately normal to the trend of the coast and of the Coast Ranges as a belt. In the axis of the syncline, and probably parallel to it, is a fault seen in the canyon between Pajaro and Chittenderi, which brings down the Tertiary rocks on the north side against the pre-Cretaceous granitic rocks of the Gavilan Range. Another interruption of the continuity of the coastal scarp is at the Golden Gate. Here the Coast Ranges have been locally depressed and the land valleys which were formerly drained by a trunk stream, where the Golden Gate now is, have been flooded by the waters of the ocean. The axis of this depression is, however, not well known. A third, apparent rather than real, interruption of the coastal scarp occurs at the place where the Point Reyes Peninsula projects out beyond the general line of the coast. Inside of the peninsula, however, there is a long narrow valley, the northern end of which is occupied by Tomales Bay and the southern end by Bolinas Lagoon, which separates it from the mainland proper; and to the east of this valley the coastal scarp rises with exceptional boldness.

The coastal scarp has had its profile modified in many places by wave-cut terraces formed during the uplift of the coast by stages in Pleistocene time, as previously stated. The relation of the coastal scarp to deformed basins of Merced (late Pliocene) strata indicate that it originated, in its essential features, at the period of orogenic activity which brought the Tertiary to a close. South of Point Conception the twofold system of faults which determines the configuration of the coast gives out and we enter upon a region of probably more complicated structure. The Santa Barbara channel appears to lie in a geosynclinal trough between the Santa Ynez range and the island chain from Anacapa to San Miguel. On the northeast side of San Clemente is a sharply defined fault-scarp, indicating that the island is a portion of an uplifted and tilted orographic block. The fault along which the scarp has been formed probably extends as far as the east side of Santa Barbara Island. San Clemente Island presents a magnificent series of wave-cut terraces up to an elevation of 1,500 feet. San Pedro Head is similarly uplifted and terraced, while the intervening island, Santa Catalina, shows no evidence of corresponding uplift, but has on the contrary been depressed. On the whole, the channel island platform between the edge of the subcontinental shelf and the coast presents the characters of a sunken mountainous tract, the inequalities of the surface of which are partly due to acute deformation and partly to erosional sculpture when the region was above sea-level. A more detailed interpretation of the structure of this region is rendered difficult by the absence of adequate soundings of the sea-bottom.

*Granitic Rocks.* •—Coming now to the consideration of the more important structural features of the Coast System, in the territory between the coast and its eastern margin, it must be stated that even here our information is very scant. One of the most important features of the Coast System from a structural point of view is the occurrence of a belt of granitic rock having a very notable linear extent thruout the ranges. This granite, as has been already stated, appears, in the vicinity of Tejon Pass, both from

<sup>1</sup> Am. Geologist, Vol. xi, Feb. 1893, p. 70.

its character and from the continuity of its exposure, to be identical with the granite of the Sierra Nevada. To the south of the Mojave Desert, it is very extensively and boldly exposed in the San Gabriel and San Bernardino Ranges and in other portions of the Coast System, as far south as the Mexican boundary. It also has broad exposures in the comparatively low-lying desert floors of Southern California, as shown by Hershey,<sup>1</sup> and in the Perris plain.

To the northwest of Tejon Pass, this granite appears in a series of linearly disposed areas extending thru the ranges. It forms a notable feature of the Santa Lucia Range on the west of the Salinas Valley, and also of the Gavilan Range to the east of the same valley. The granite of the Santa Lucia Range runs out to sea at Point Pinos near Monterey, while that of the Gavilan Range extends into Santa Cruz County and appears on the coast at Point San Pedro, a few miles south of San Francisco. Farther north it is seen in the Farallon Islands, the Point Reyes Peninsula, and on Bodega Head. The Santa Lucia and the Gavilan thus expose two quite distinct lines of granitic outcrop, practically parallel, and both crossing the general trend of the Coast Ranges obliquely and reaching the coast. Indeed, the easterly limit of all the granite of the Coast Ranges crosses the entire breadth of the latter obliquely between the Tejon Pass and Bodega Head. This signifies, of course, that whatever manifestations of crustal deformation elevated these belts of granite, the lines or axes of such deformation were not coincident in direction with the mean trend of the Coast Ranges, or with the mean trend of either of the margins of the Coast Ranges. It is noteworthy, too, that all of the Coast Range granite as far south as the vicinity of Tejon Pass lies to the southwest of the Rift along which the movement occurred which generated the earthquake of April 18, 1906. It is further noteworthy that near the northern end of the granite belt at Tomales Bay and Bodega Head, the Rift actually follows the line of contact between the granite on the west and the sedimentary rocks which are faulted against it. These facts suggest that very probably the Rift is similarly situated in the more southern Coast Ranges with reference to a deeper-seated contact between granite and sedimentaries; in other words, that the eastern edge of the Coast Range batholith, whether that edge be an original feature of the batholith or a feature determined by faulting, is with some degree of probability the line which determines in part the course of the modern Rift. Southward from the vicinity of Tejon Pass, however, the Rift passes into the granitic terrane.

*Folds.* — The pre-Knoxville folds of the Coast Ranges are little known, owing partly to the burial of the Franciscan rocks by later deposits, and partly to the complexity of the structures where the rocks are exposed and the difficulty of discriminating the effects of the earlier and the later movements; but chiefly owing to the absence of adequate topographic maps, so necessary for such studies. The conspicuous folds of the Coast Ranges are those which have been impressed upon the Tertiary and older strata together. These are usually rather sharp and more or less symmetrical synclines and anticlines, involving usually many thousands of feet of strata. In some cases these are asymmetric and even overturned, as in the Mount Diablo region, but they are never so closely appressed as to induce general and important deformation of the internal structure of the rocks affected. The folding has been effected without flowage, except perhaps locally where soft clays or shales were involved, and there has been no development of slaty cleavage or schistosity. In general the axes of the folds have a northwest-southeast trend, but there are numerous deviations from this rule and the axes of the minor folds are usually more or less divergent, as is of course generally true. There is, however, a pronounced parallelism in the dominant synclines and anticlines, the axes of which extend for many miles. Several of these are more or less oblique to the mean trend of the Coast Range belt, and thus appear to be truncated on the coast line, or on the eastern margin of

---

<sup>1</sup> Bull. Dept. Geol. Univ. Cal., vol. 3, No. 1.

the ranges. The coincidence of many of the larger valleys with a synclinal axis is very marked.

*Faults.* — In the Coast Ranges there are numerous faults, but our knowledge of them is limited, owing to the small amount of geological mapping which has been done in the region. With the extension of cartographic work, many more than are now known will doubtless come to light. Of those at present known, the great majority have a general northwest-southeast strike, but there are several minor faults which trend transverse to the general strike. The faults of the Coast Ranges, as well as those of other parts of California, are indicated, as to position and extent, on Map No. 1. A summary reference to them is all that will be here attempted.

The most northerly fault of the Coast Ranges is one which Mr. O. H. Hershey calls Redwood Mountain fault. It is an overthrust, according to Mr. Hershey, heading to the northeast and having a throw of probably over 5,000 feet. It trends southeast along the southwest flank of South Fork Mountain for scores of miles, and doubtless determines the very straight trend of this great ridge. Parallel to it, on the southwest side of Redwood Creek, near Acorn, there is another fault having a throw of at least 1,000 feet, according to Mr. Hershey. Its extent is unknown. The precipitous southwest front of Mount St. Helena has been shown by Osmont \* to be a degraded fault-scarp; and the downthrow on the southwest side of the fault is estimated by him to be not less than 2,500 feet. The western edge of the Sacramento Valley, from Benicia to Cordelia, is probably determined by a fault with an easterly downthrow.

In the Mount Diablo region, there is a pronounced overthrust fold which causes Miocene strata to rest upon Pliocene strata with a dip of 30° to 45° to the northeast. Louderback's work on the structure of Mount Diablo has shown that this over-tipt fold passes into a thrust fault whereby a considerable proportion of the mountain has been shoved to the southwest.<sup>2</sup> The west side of San Ramon and Livermore Valleys is bounded for the most part by a steep mountain wall at the base of which, near Pleasanton, the Tertiary rocks are faulted down against the Franciscan. This fault extends southward thru Calaveras Valley and past Mount Hamilton. Its general course is about N. 35° W. It has an extent of at least 60 miles and may be very much longer. In the Berkeley Hills to the east of this there are many minor faults, both overthrust and normal, which will not be described in detail. In the Mount Hamilton Range, between the crest and the Santa Clara Valley, there are several faults, notably the Mission Creek, Mission Peak, Mount Hamilton, and Master's Hill faults, which have a more or less regular northwest-southeast trend; and there are several shorter faults transverse to these, and of variable strike.

The valley of the Bay of San Francisco and its prolongation southward in the Santa Clara Valley is bounded on the northeast side by a range of hills which presents a very even, straight, and on the whole, but little undulated, front to the southwest. This even front extends from near Point Pinole, on San Pablo Bay, to the vicinity of Hollister, a distance of about 100 miles, forming a very striking geomorphic feature of the Coast Ranges. At Berkeley and Oakland, and southeast of the latter, there is evidence that this even front represents a somewhat degraded fault-scarp, or series of scarps, and this interpretation may with very probable truth be placed upon it for its entire extent. Near Berkeley the slope of this degraded scarp is traversed by supplementary step faults, which are not improbably characteristic of it in other places; so that in regarding the feature as a fault-scarp it is not intended to apply that term too narrowly, but to include rather the idea of a zone of acute deformation traversed by step faults. This line has a course of about N. 35° W. North of San Pablo Bay, on the geographic prolongation of the line, a similar feature, though by no means so straight, is found on the east side of the

<sup>1</sup> Hull. Dept. Geol., Univ. Cal., vol. 4, No. 3, p. 78.

\* Results not yet published.

Santa Rosa and Russian River Valleys up to about Cloverdale. Here, however, evidence of faulting is lacking, altho it is known in places to be a line of flexure. Along the base of this line of scarp, between Oakland and San Jose, occurred the fault which caused the earthquake of 1868. It may be referred to as the Haywards fault, from the fact that it passes thru that town.

An interesting and important fault traverses the peninsula of San Francisco, a little south of the city. The course of this fault can not be precisely determined, as its trace at the surface is obscured by Pleistocene and recent deposits. Its approximate position is at the southwest base of San Bruno Mountain, with a strike of about N. 43° W. By this fault the Merced strata, which are well exposed on the sea-cliffs south of Lake Merced to the thickness of over a mile, are dropt down against the Franciscan rocks, the throw being estimated at not less than 7,000 feet. To the northeast of the main fault, and close to the face of the mountain, is an auxiliary fault, and between these two faults there is a block of the Franciscan which has dropt only to a limited extent, and which is of the same character as the kernbutts of the Kern River.<sup>1</sup> The bold and precipitous southwest face of San Bruno Mountain is thus a fault-scarp with two facets, one for the main fault and the other for the auxiliary, both being well exprest in the geomorphic profile of the mountain. This fault-scarp appears to be the southern prolongation of the scarp which forms the coastal steep slope to the north of the Golden Gate, and seems to converge upon the San Andreas fault, off the Golden Gate, making a very acute angle with it. It affords an excellent illustration of the general fact above alluded to, that the northwesterly members of the fault system controlling the configuration of the coast are prolongations of fault-lines within the Coast Ranges. Knowledge of the extent of this fault, altho its throw is so notable, is limited to the peninsula of San Francisco.

Outside of Fort Point, at the Golden Gate, and a little south of the point, is a very well exposed fault which appears to strike southeast across the city of San Francisco. The fault is nearly vertical and has a throw of at least some hundreds of feet, whereby the serpentine on the north has beer dropt against a formation of radiolarian cherts.

The most interesting fault traversing the Peninsula of San Francisco is the San Andreas fault, on which movement was renewed on April 18, 1906, causing the earthquake. The extent and course of this fault are described in detail elsewhere. To the southwest of the San Andreas fault, on the Peninsula of San Francisco, and in the Santa Cruz Mountains, are several other faults of notable extent. Of these may be mentioned the Fifield, Pilarcitos, Castle Ridge, Butano, Boulder Creek, and San Gregorio faults, all of which are important features of the structure of the region.

On the southwest side of Montara Mountain is a very precipitous seaward slope, at the base of which strata of Miocene age are tilted at rather abrupt angles against the granite. The strata of arkose sandstone at the base still rest against the original floor of deposition, but it is difficult to see how such an acute uplift could take place in a granite *massif* without deformation of the granite. Such deformation might take the form of plastic flow if it were sufficiently deep-seated, or it might find its expression, in a zone of faults; and as there is no evidence of plastic deformation, it is concluded that the uplift of Montara Mountain was effected by faulting within the granite, the same deformation appearing as flexure in the stratified rocks which flank the mountain on this side.

Northeast of the San Andreas fault are the Belmont and Black Mountain faults, the latter a branch from the San Andreas fault. In the gap between the Santa Cruz and Gavilan Ranges is a fault followed by the canyon of Pajaro River near Chittenden, which drops the Tertiary formations on the north against the pre-Franciscan granitic rocks of

---

<sup>1</sup>Bull. Bept. Geol., Univ. CaL, vol. 3, No. IS.

the Gavilan Range on the south. This fault is interesting for several reasons: it lies approximately in the axis of the geosyncline of the Bay of Monterey; it is transverse to the San Andreas Rift and intersects it; and it is near the place where the surface rupture of the San Andreas fault ceased on April 18, 1906.

South of the Bay of Monterey, one of the dominant structural lines of the Coast Ranges is the Santa Lucia fault, at the base of the Santa Lucia Range on the border of Salinas Valley. It is traceable from the vicinity of Bradley to the Bay of Monterey and it is probably the chief factor in determining the course of the Salinas-Valley and the steep easterly front of the Santa Lucia Range. Near its southern end, the Santa Lucia fault is paralleled on the southwest by another fault which probably determined to some extent the course of the valley of San Antonio River. Farther south a fault parallels the last two, between Dove and Templeton; and to the southwest of this lies the much longer fault which passes close to San Luis Obispo, extending from near San Simeon to the drainage of the Santa Ynez.

The northeastern flank of the San Emidio Range, at the southern end of the great valley, is with little question a fault-scarp. The same may be said of the north flank of the Santa Ynez Range and the south flank of the Santa Monica Range. The San Gabriel fault, which bounds the range of that name on the south, branches from the San Andreas fault near San Bernardino and follows the base of the range with an east-west trend. Beyond Pasadena it bends slightly to the north and extends thru to the coast in the vicinity of Carpenteria. Near Pasadena a branch fault leaves it, with a northwesterly strike, on the northeast side of the Verdugo Mountains. Southeast of Los Angeles, the most notable faults are the San Jacinto and Elsinore faults, both of which have very pronounced scarps. There are, however, several others. All the faults in this region have a northwest-southeast strike, and are thus in contrast to the system of faults extending from Point Conception to the Colorado Desert along the Sierra Madre, in which the dominant trend is east and west.

The foregoing summary enumeration of the more important faults at present known in the Coast System of mountains makes it clear that the San Andreas fault, upon which movement took place on April 18, 1906, is not a singular or unique feature of the structure of these mountains. It is only one of many faults, on all of which in time past there have occurred many differential movements, each productive of an earthquake. Map No. 1, upon which the above faults are represented, indicates other faults in California, Nevada and Oregon at present known to geologists.<sup>1</sup> Perhaps the most interesting of these, from the present point of view, is the fault at the eastern base of the Sierra Nevada, upon a portion of which the movement took place that caused the earthquake of 1872. The map may be regarded as a preliminary attempt to bring together, in cartographic form, our knowledge of the position of faults in this region. A full discussion of these features, with references to the literature bearing upon them, would be out of place here, altho their occurrence suggests seismic possibilities.

#### GEOMORPHIC FEATURES.

Certain of the geomorphic features of the Coast Ranges, particularly as regards their margins, have necessarily been alluded to in the discussion of the structure. It is proposed here to describe quite briefly the salient characters of the relief, in their relation to the structure.

The Coast Ranges in general, between the coast and the Great Valley and north of Santa Barbara Channel, comprize a series of ridges and intervening valleys of mature aspect.

<sup>1</sup> In compiling the data for the representation of the faults of California, free use has been made of information kindly supplied by Messrs. H. W. Turner, W. Lindgren, W. C. Mendcnhall, H. W. Fairbanks, J. S. Diller, P. M. Anderson, It. Arnold, J. C. Branner, G. D. Louderbaek, and O. H. Herahey.

The ridges exhibit for the most part a pronounced parallelism in a direction more or less oblique to the mean trend of the coast and of the Coast Ranges as a belt. The highest of these ridges rarely exceed 5,000 feet in altitude and their crests usually range between 2,000 and 4,000 feet above sea-level. Rarely the tops of the ridges are more or less flat, presenting the character of a rolling upland, the rule being that the crests are determined by the intersection of the valley slopes on either side. In the northern Coast Ranges, however, it is generally true that the ridge crests over wide areas reach about the same altitude and give the observer the impression of a dissected upland of fairly uniform and gentle slope. The valleys in which the streams flow are usually wide-bottomed in the softer formations and narrow in the harder rocks. In such portions of the region as have been geologically examined, it appears clear that the courses of these streams are closely, tho of course not wholly, controlled by the strike of the rocks or the strike of faults. The general scheme of drainage is that which might be termed subsequent, the streams having adjusted themselves to the structural lines, and having been greatly extended by headwater erosion along those lines at the expense of original consequent streams, traversing the region transversely to the trend of the structure to the sea on the one side, and to the Great Valley on the other. This interpretation is rendered more plausible by the fact that, in a general way, the broad structure of the Coast Ranges appears to be that of a geanticline, with various subordinate folds, the dissection of which by erosion reveals the Franciscan rocks in the central portion of the ranges, flanked on either side by rocks of later age. This interpretation appears to be quite acceptable for the Eel River and its various branches, which constitute the chief drainage of the northern end of the region. This drainage has all the characters of a subsequent system, and is in harmony with the mature aspect of the ridges and valley slopes. All the numerous tributaries of the river flow in longitudinal valleys, parallel or subparallel to one another, and connected by short transverse streams cutting thru the intervening ridges; and the course of the longitudinal valleys is that of the strike of the rocks, being, like the latter, oblique to general trend of the Coast Range belt. Thruout this region, within the hydrographic basin of the Eel River, there are below the crests of the ridges numerous instances of high valleys and broad, more or less obscure terraces, representing an inheritance from earlier stages of the geomorphic evolution of the region, when it stood at lower levels than at present. These have been described<sup>1</sup> in a valuable paper by Diller.<sup>1</sup>

between the headwaters of Eel River and the Bay of San Francisco the interpretation of the drainage as subsequent is not so certain, altho here the general geomorphic profile is even more mature than it is on the north, a fact referable to the softer character of certain geological formations which prevail. Here we have, as before, a system of stream valleys, notably Russian River Valley, Sonoma Valley, Napa Valley, and Berryessa, and Clear Lake Valleys, which are clearly evolved by stream erosion under the control of structure. The transverse connecting link from one longitudinal valley to another, which is so characteristic of subsequent drainage, is not apparent on the maps, but its absence may be more apparent than real. The lower stretch of Russian River, from Healdsburg to the sea, has the appearance of a transverse stream tapping a longitudinal valley of very mature character, and may be the remnant of an original consequent stream. This view, however, is open to the objection that the lower stretch of Russian River near the sea has a more youthful aspect than might reasonably be expected under the hypothesis. On account of the rather immature character of the transverse outlet of Russian River, it has been suggested that it is of later date than Russian River and represents a small stream which has cut its way back from the coast and captured the waters of the river, which formerly went to the Bay of San Francisco, the capture being

<sup>1</sup> U.S. Geol. Surv. Bulletin, 196.



facilitated by the deformation of the region. The offsetting consideration to this objection, based on the less mature aspect of this part of the valley, is that it traverses much harder rocks than are found in the wider valley above. In a word, the view that the lower transverse stretch of Russian River may be the remnant of an original consequent stream, from which, by subsequent development, has been evolved the longitudinal Russian River Valley, has not yet been satisfactorily negated.

Somewhat similar features occur on the east side of the Coast Ranges. Cache Creek and Putah Creek, draining longitudinal valleys within the Coast Ranges, both emerge upon the Great Valley thru transverse gorges in the Blue Ridge, the most easterly of the Coast Ranges. These transverse gorges can scarcely be regarded as other than consequent trunks crossing a hard barrier within which, in softer formations, longitudinal or subsequent valleys have been evolved. The apparent absence of the transverse connecting links between Napa, Sonoma, and Petaluma Valleys is explained when it is recalled that while the streams draining these valleys flow directly to salt water, they nevertheless flow to a drowned valley. The trunk stream trench from which Petaluma, Sonoma, and Napa Creeks are subsequent branches lies below the waters of San Pablo Bay. In general, Santa Rosa Valley (lower part of Russian River Valley), Petaluma Valley, Sonoma Valley, and Napa Valley have been evolved by erosion along synclinal axes. This fact also tends to weaken their interpretation as due to subsequent development by headwater erosion; since, if the synclinal folds were expressed as troughs at the surface at the time of the folding, then the drainage would have been both consequent and parallel to the structure.

Coming farther south, the valley of the Bay of San Francisco and its extension in the Santa Clara Valley is a large feature in which deformation and erosion have probably played equal rôles. Its trend is strictly determined by the Hayward fault line previously described. Southward from Hollister, the valley loses its breadth and passes into the much more constricted valley of the San Benito River, draining the Coast Ranges to the east of the Gavilan Range. The Bay itself and its inland extensions afford a magnificent illustration of a drowned valley-land due to subsidence of the valley-bottoms below sea-level.

Livermore Valley, a few miles to the east of the Bay of San Francisco and separated from it by the ridge of the Berkeley Hills, is a very noteworthy feature. It is a broadly expansive alluviated valley, bounded on the west by the degraded fault-scarp which limits the Berkeley Hills to the east; on the east by the slopes of Mount Diablo; and on the south by the slopes of Mount Hamilton. On the north it is open by way of the wide and low San Ramon Valley to Suisun Bay, and the northern portion of the valley drains this way. The greater part of the waters which come to it from Mount Diablo and from Mount Hamilton, however, are carried off by Alameda Creek thru Niles Canyon, a narrow gorge which transects the bold ridge separating it from the Bay of San Francisco. Alameda Creek has a hydrographic basin of 600 square miles, and it is a remarkable fact that it finds its outlet across the strike of the range thru a bold ridge, instead of following the wide open valley leading directly to Suisun Bay with no barrier in its path. It is a fair inference that Livermore Valley is structural rather than erosional in its origin and that, anterior to the acute deformation of the region, the drainage was consequent in the path followed by Niles Canyon. The deformation involved the uplift of the Berkeley Hills and the complementary depression of the Livermore Valley tract, and this deformation proceeded at a rate which was sufficiently slow to permit the stream, by downward corrosion across the rising mass, to maintain its course. Alameda Creek in Niles Canyon is thus a remnant of the consequent drainage of the region and is antecedent to the uplift which gave rise to the Berkeley Hills.

In the Coast Ranges between the Bay of Monterey and the Santa Barbara Channel, the chief valleys are those of Salinas River and its tributary, the San Juan; the Carissa Valley, and the valleys of the Cuyama and Santa Ynez Rivers. Of these the Salinas Valley is the largest. It is a wide, terraced valley cut by the river out of rather soft Tertiary and later deposits, which appear to have been in part let down against the older rocks of the Santa Lucia Range by the Santa Lucia fault. In its lower part it lies between the Gavilan and Santa Lucia Ranges, and the trend thus established is maintained by the main stream as far as San Miguel. Beyond that the same general trend is continued up its tributary, the San Juan, and thence thru the Carissa Plains to a point close to the southern end of the Great Valley. The eastern side of the upper end of the valley, particularly the eastern side of the Carissa Plains, follows closely the line of the modern earthquake rift to be presently described; and there can be little doubt, not only that in so far as the valley is an erosional feature its erosion has been controlled by structural features, but also that deformational processes have had a considerable share in its evolution. The axis of the valley thus indicated is singularly straight and has a length of about 175 miles. Its upper part, the Carissa Plains, is an arid plain without drainage and contains a very saline lake. This plain is a surface of alluviation. The lower end of the valley opens widely on the Bay of Monterey and the fine stream terraces which flank its sides afford an excellent record of the recent uplift of the region.

The valley affords another striking illustration of the obliquity of the geomorphic as well as the structural features to the general trend of the Coast Range belt, and their constant tendency to emerge upon the coast. From the eastern margin of the valley at the south end of the Carissa Plains, one can look down upon the Great Valley, near Sunset, a few miles distant; and only a narrow ridge separates the two valleys, altho they differ greatly in altitude. From this point in its course of 175 miles, Salinas Valley crosses the entire width of the Coast Ranges. South of San Miguel, the Salinas River proper lies in a less open valley with north and south trend as far as Templeton, a distance of about 15 miles, and then opens out into a wider valley having a northwest-southeast trend for about 35 miles to the headwaters of the stream. Several of the minor tributaries of the Salinas show a marked tendency to the development of subsequent valleys. On the east side of the river, this is particularly marked on San Lorenzo Creek in Priest Valley, and on Chalome Creek in Chalome Valley. These comparatively large valleys may be referable in part, however, to deformation, inasmuch as they are on the line of the Rift. Their geomorphic history has not yet been studied. On the west side of Salinas Valley the two chief tributaries, the San Antonio and the Nacimiento, have developed well-defined subsequent valleys in the heart of the Santa Lucia Range.

In the valley of the Cuyama or Santa Maria River, the effect of a twofold structural control is apparent. The upper reaches of the river flow thru a broad valley with an alluviated bottom on the northeast side of the San Rafael Range. The general trend of the river in this part of its course is northwest-southeast, and it is separated from the Carissa Plains by a high mountain ridge with a very precipitous southwest front, which probably represents a fault-scarp. Below this expansive high valley, the stream enters a rather narrow canyon and shortly after this bends at right angles and flows southwest toward the coast, entering eventually on the broad Santa Maria Valley which is open to the sea. The contrast in the geomorphic character of the upper and lower reaches of the river, the greater age of the former, and the sudden change in the course of the stream where the two types of geomorphy meet, suggests that the high valley of the upper reaches was once connected with the Salinas drainage and that it has been captured from the latter, in comparatively recent time, by a stream cutting back from the coast at the northwest end of the San Rafael Range.

In the valley of the Santa Ynez, there is a marked departure from the northwest-southeast trend which characterizes the geomorphic features of the Coast Ranges in general, and a more striking instance than any yet cited of the obliquity of those features to the general trend of the Coast Range belt. The valley lies nearly east and west and its general slope is southward to the base of the precipitous northern face of the Santa Ynez Range. This face is, as has been indicated, a fault-scarp; and the course of the valley is thus seen to be in intimate relation to this dominant structural feature. To the west the valley opens widely to the sea, while to the east it loses its individuality in the headwater canyons of eastern Santa Barbara County and western Ventura County.

Between the Santa Ynez Valley and the upper Cuyama is the rugged and deeply dissected country culminating in the San Rafael Mountains on the northern side of the tract. This mountainous belt has a trend intermediate between the pronounced east-west trend of the Santa Ynez Range and the northwest-southeast trend of the Coast Range ridges and valleys to the north. For a portion of its length the belt is bounded on the south by the Santa Clara Valley, with a general east and west course; but across the headwaters of Santa Clara River the mountainous tract persists and finds its prolongation, with the same general trend, in the San Gabriel Range, and beyond Cajon Pass in the San Bernardino Range, both bold and lofty sierra. It may even be considered as extending, under the name of the Chocolate Mountains, to the Colorado River above Yuma. From Tejon Pass southeast to Cajon Pass, the northern side of this mountain tract presents a very abrupt front with a very straight course. At the base of the abrupt slope lies the San Andreas Rift. To the north of this, and between it and the southeast scarp of the southern Sierra Nevada, lies the Mojave Desert. To the south of the southeast end of the San Bernardino Range and west of the Chocolate Mountains lies the Colorado Desert. As has been already indicated, the south side of the San Gabriel Range is determined by a profound fault. Lying thus between two faults, the range is a magnificent example of a horst which has been thrust up between its bounding faults. It is the convergence of these two bounding faults which segregates the San Gabriel Range from the San Bernardino Range in the vicinity of Cajon Pass. The latter range is similarly bounded on the south by the same fault as that which determines the south front of the San Gabriel Range, but here it is coincident with the Rift. Between Los Angeles and Ventura lie the short ranges known as the Santa Monica and the Santa Susannah Mountains, inclosing San Fernando Valley. The Santa Monica Range is probably on the same line of orogenic uplift which finds its expression farther west in the Santa Cruz and Santa Rosa Islands.

South of the San Gabriel Range lies the fruitful valley of southern California, extending with an east-west course from the sea to San Bernardino. South of this valley, and between the Colorado Desert and a somewhat elevated coastal plain bordering the Pacific, is a mountainous tract, the ridges of which swing around into a more northwest-southeast trend, and so conform again with the prevailing trend of the ridges and valleys of the Coast Ranges north of the San Rafael Mountains. The valleys in this region are, however, less regular in their orientation than those of the northerly Coast Ranges, and the geomorphic features are less mature, if we except certain very old features which have survived from an earlier cycle of geomorphic evolution. The consequent character of the streams on the seaward slope is much more pronounced than in any part of the northern Coast Ranges, and on the whole the geomorphy of the region must be regarded as less advanced than to the northward, and more closely allied in its morphogeny with the Sierra Nevada than with that of the Coast Ranges of northern California.

The notable ranges of this region are the Santa Ana Mountains and the San Jacinto Mountains. The former present the features of a seaward sloping, tilted, orographic

block, with a very straight and abrupt fault-scarp facing the northeast and overlooking the Perris Plain. This is an elevated, and as yet little dissected, peneplain with remnants of Tertiary or later deposits resting upon it, indicating that it has, in part at least, but recently been resurrected from a buried condition. In San Diego County the Santa Ana Mountains find their prolongation in a less regular and broader group of ridges, but doubtless the same tilted block structure prevails to the international boundary and beyond, since the northeast scarp appears to persist in the same general trend, and the same type of consequent drainage characterizes the seaward slope. Still east of the line of the scarp in southern San Diego County, there is another orographic block, bounded on the east by a very recent and very precipitous scarp looking out over the desert.<sup>1</sup> To the northwest the range becomes subdued in the Puente Hills, where a broad anticlinal structure replaces in part the deformation by faulting. In two notable instances, and perhaps in others, the seaward streams of the Santa Ana Mountains cut entirely thru the range and drain the valley-land beyond its northeasterly scarp. These are the Santa Ana and the Santa Margarita Rivers. They are both probably antecedent to the more acute phases of the tilting, of the region and have persisted in their course during the development of the fault-scarp.

The San Jacinto Mountains form an important feature of the region as a bold ridge with northwest-southeast trend lying between Perris Plain and the northern end of the Colorado Desert. Both sides of the range are precipitous and are probably determined by faults. On the southwest side there were notable ruptures of the ground in the earthquake of 1898, indicating that the fault on that side is still in active development.

---

<sup>1</sup> Verbal communication from Dr. H. W. Fairbanks.

## THE SAN ANDREAS EIFT AS A GEOIOEPHIC FEATURE.

### GENERAL.

Extending thru the greater part of the Coast System of mountains from Humboldt County to the Colorado Desert, a distance of over 600 miles, is a line or narrow zone characterized by peculiar geomorphic features, referable either directly to the modern deformation of the surface of the ground or to erosion controlled by the lines upon which such deformation has taken place. This peculiar feature has been known, both to Californian geologists and to residents of the sections where its characters are most prominent, but its extent and importance were not fully appreciated until after the earthquake of April 18, 1906. It is commonly reported among the residents of the southern interior Coast Ranges, particularly in San Benito, Monterey, and San Luis Obispo Counties, that displacement of the ground occurred on this line in the earthquake of 1857 and in certain later earthquakes. The first reference in scientific literature to this feature appears to have been in the year 1893, in a paper entitled "The Post-Pliocene Diastrophism of the Coast of Southern California," by Andrew C. Lawson, which is quoted in the sequel. The next reference to this peculiar line is in the eighteenth annual report of the U. S. Geological Survey for 1896-1897, Part IV, in a paper by Schuyler on "Reservoirs for Irrigation," where, pp. 711-713, the significance of the line is fully recognized in the following words quoted in full:

This reservoir has especial interest, not only as the first one of any magnitude completed on the Mojave Desert or Antelope Valley side of the Sierra Madre in southern California, but because it lies directly in the line of what is known as "the great earthquake crack" of this region, which is marked by a series of similar basins behind a distinct ridge that appears to have been the result of the great seismic disturbance.

This remarkable line of fracture can be traced for nearly 200 miles thru San Bernardino, Los Angeles, Kern, and San Luis Obispo Counties, and deviates but slightly here and there from a direct course of about N. 60° to 65° W. There appears to have been a distinct "fault" along the line, the portion lying south of the line having sunken and that to the north of it being raised in a well-defined ridge. In many places along the great crack, ponds and springs make their appearance, and water can be had in wells at little depth anywhere on the south side of the ridge before mentioned. A tough, plastic, blue clay distinguishes the line of the break, in this portion of its course at least; and where the line crosses Little Rock Creek, the blue clay has formed a submerged dam, which has forced the underflow near the surface and created a "cienega" immediately above it. After crossing the line, the water of the creek drops quickly away into the deep gravel and sand of the wash. The same effect is noticeable at other streams, and it has been suggested as the probable cause of the very distinct rim marking the lower margin of the San Bernardino Valley artesian basin and confining its waters within well-defined limits, as this rim is nearly on a prolongation of the line that is traceable on the north side of the mountains —\* the break having crost the mountains thru the Cajon Pass on the line of Swartout Canyon.

In 1899 the essential features of the same line in the region north of the Golden Gate were recognized and discust by F. M. Anderson.<sup>1</sup> In later years Dr. H. W. Fairbanks has traced out the line in various field trips and has given several public lectures descriptive of its features and its significance, but has published no systematic account of his studies.

The fact that the earthquake of April 18, 1906, was caused by a rupture and displacement of the earth's crust along this line for a distance of about 190 miles, immediately focussed the attention of local geologists upon it. Among those engaged upon

---

<sup>1</sup> The Geology of the Point Reyes Peninsula, Bull. Dept. CJeol., Univ. Cal., vol. 2, No. 5, p. 143 *ei Seq.* Anderson, however, supposed, as is indicated by the last paragraph of his paper, that the faulting antedates entirely the Pleistoeene terrace formations.

its investigation, it became known as the "rift line." Since the earthquake it has been traced as a geomorphic or physiographic feature from Humboldt County to the Colorado Desert, with a possible gap between Shelter Cove and Point Arena, where, if continuous, it lies beneath the Pacific. Its continuity has, however, been satisfactorily established from Point Arena to Whitewater Canyon, at the northern end of the Colorado Desert, a distance of 530 miles. Thruout this entire distance it lies along depressions or at the base of steep slopes which are either the direct result of crustal displacement or of stream erosion, operating with exceptional facility along lines of displacement. There can be no doubt that the displacements have been recurrent thru a considerable part, if not the whole of Pleistocene time, and that in parts of its extent, at least, the movements have taken place on fault-lines which originated in pre-Miocene time. The later movements on this line have given rise to minor features which subaerial and stream erosion have not yet obliterated, and it is these minor features chiefly which have attracted attention to the Rift by reason of their striking contrast with more common geomorphic forms due to erosion. These minor features are chiefly low scarps and troughs bounded on one or both sides by low, abrupt ridges in which frequently lie ponds or swamps of quite small extent.

A summary account will now be given of this rift line as a geomorphic feature.

#### HUMBOLDT COUNTY.

The most northerly point in California at which geomorphic features directly referable to the violent rupture of the earth's crust have been observed are those noted by Mr. F. E. Matthes in the vicinity of Petrolia in Humboldt County. Here south of Petrolia, on high bare mountain spurs between Cooskie, Randall, and Spanish Creeks, he reports the occurrence of several small ponds and ridges such as have been familiar to those engaged in the field study of the earthquake phenomena as characteristic Rift features. Similar features are also found at the base of these spurs near the shore. These are in line with similar features found by the same observer between Telegraph Hill and Shelter Cove, a few miles to the southeast. Here, particularly in Wood Gulch (plate 1) is a narrow depression with ponds, ridges, and saddles, which appears to be essentially a feature due to deformation and to have determined the course of the drainage. The course of the depression is about  $F. 25^{\circ} W.$ ; In this depression lies the trace of the fault upon which movement took place on April 18, 1906. Its course, if followed southward to the cliffs above Shelter Cove (plates 2A, 3A, B), heads out to sea with a trend nearly parallel to the coast. Great landslides occur along the coast in proximity to this line, and are in part on the Rift. The rocks traversed by the Rift in this part of Humboldt County appear to consist wholly of shales, sandstones, and conglomerates which are probably of Cretaceous age, altho since the geology of the region has not been studied, positive statements in this regard can not be made. The region, is high and rugged, with a very precipitous descent to the sea, King Peak having an elevation of 4,090 feet at a distance of about 2 miles from the shore.

#### POINT ARENA TO FORT BOSS.

From Shelter Cove to near Point Arena, the Rift, if continuous, lies beneath the waters of the Pacific. The continuity for this stretch is of course open to question, and in another place the considerations bearing upon this point will be presented. At the mouth of Alder Creek, 4.5 miles northwest from Point Arena, the Rift enters the coast from the sea and is thence traceable continuously to a point about 2 miles southeast of Fort Ross, a distance of about 43 miles, with a nearly but not quite straight course, being slightly curved with the convexity toward the ocean. (See map No. 2.) For our knowledge



A. Wood Gulch, Humboldt County. The Eift near its northern end. A. S. E.



B. Another view of the Rift. Wood Gulch. A. S. E.

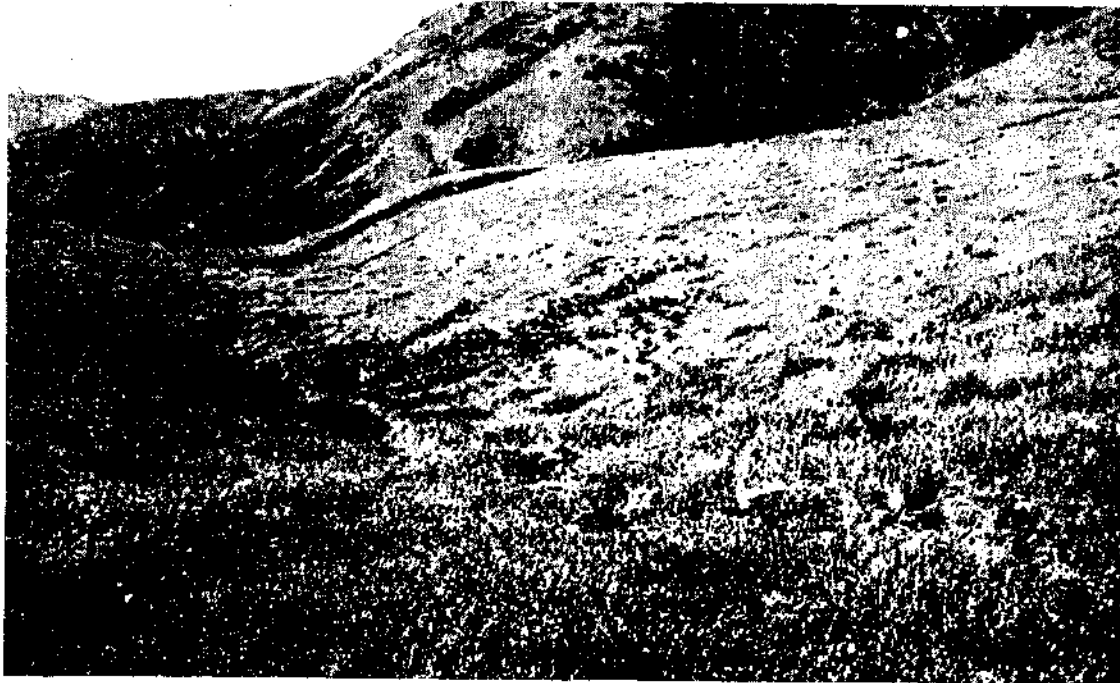

A. The Eift above Shelter Cove, Humboldt Comity. A, S. E.



B. The Eift on the divide between the upper Guaiala and the coast north of Port Rosa. H. W. F.





A. The Eift above Shelter Oove, looking northwest. The fault-line follows old diatrophic features. P.E.M.



B. Northeast of Shelter Oove. Eift in the middle ground. F. B. M.



C. Looking up Garcia Eiver along the Eift. F. E. M.



D. Looking up Garcia Eiver along the Eift. F. E. M.



A. Characteristic Rift features southeast of Fort Eosa. Figure on fault-trace, A, C. L.



B. Characteristic Eift features southeast of Fort Eosa. Fault trace in foreground. A. C. L.

of the features of the Rift for this part of its course, we are chiefly indebted to the observations of F. E. Matthes and H. W. Fairbanks. For this stretch, its course is somewhat more meridional than the trend of the coast, so that it converges steadily southward upon the shore line, and finally intersects it below Fort Ross. Between the mouth of Alder Creek and the Garcia River the Rift is marked across a low, rolling country by a series of depressions, swamps, and ponds, many of which are without outlet. At the point where it intersects the Garcia River, the valley of the latter from that point upstream for a distance of 9 miles follows the Rift (plate 3c, D), and its course has with little question been determined by the structural conditions inherent in the Rift. On the southwest side of the valley the minor features of low ridges and swamps are common, and there are in places two sets of parallel ridges. From the head of the longitudinal valley of the Garcia, the Rift passes over a sag in the mountains to the Little North Fork of the Gualala River. From this point southeast, the Rift follows the common and very straight valley of the Little North *Fork* and the South Fork of the Gualala. This valley is separated from the coast by a ridge varying in height from 300 to about 1,000 feet. The Rift follows the valley, or rather the valley follows the Rift, for a distance of about 18 miles, and is characterized by the usual abnormal features of low ridges, with elongated swamps and ponds between, extended parallel to the river. The ridges again evince a tendency to appear in pairs, which is peculiarly marked near Stewarts. North of Plantation House the Rift passes over a broad, swampy divide in the coastal ridge (plate 2B), and at the House is marked by two small ponds. South of the Plantation House is a series of swampy hollows extending toward Buttermore's ranch. The latter lies in a broad, swampy saddle. From Buttermore's ranch southeastward the Rift is marked by a line of deformation traversing the uplifted wave-cut terraces and sea-cliffs which are notable features of this part of the coast. Low ridges with northeasterly scarps form barriers which pond the surface waters and give rise to numerous ponds and small swamps or elongated hollows. Several small ravines and gulches lie in its course, and occasionally a landslide is clearly related to the path of the Rift. In the vicinity of Fort Ross, the geomorphic forms of the Rift are particularly well exemplified and a typical stretch of the latter is cartographically represented on map No. 3. Low ridges up to 10 feet in height, some with mature rounded slopes, others with abrupt slopes to the northeast, mark its course. Alined with these are scarps which, by reason of their monoclinical slopes, can scarcely be called ridges. Behind the ridges and scarps are pools and small swamps. Some of the small streams follow the Rift and have established notable ravines along its course. (Plates 4 and 5.)

With regard to the geology of the territory traversed by the Rift from the vicinity of Point Arena to Fort Ross, Dr. H. W. Fairbanks has kindly examined the ground and supplied the following note:

Except for a strip of sandstones (Walalla beds) of upper Cretaceous age extending along the coast north and south of the mouth of the Gualala River, and a triangular area of Monterey shale and sandstone underlying the coastal terraces in the vicinity of Point Arena, the rocks of almost the entire mountainous region between the upper Russian River Valley and the coast belong to the Franciscan. There seems to be but one fault in this region, and that is on the line followed by the Rift. The Walalla beds begin upon the coast a little south of Fort Ross and, extending inland, form the ridge between the Gualala River and the ocean. The formation thins out against the ridge bounding the Gualala Valley upon the northeast. The line of junction is an irregular one, for in places the soft sandstones reach quite to the top of the ridge referred to. These beds extend along the coast to the northwest for more than 30 miles, finally terminating 7 or 8 miles south of Point Arena, where they are overlain by the Monterey sandstones and shales. The Rift does not follow the contact between the Walalla and Franciscan formations and the vertical displacement does not appear to have been very great, as in only one place was it enough to bring up the underlying Franciscan rocks upon one of its walls. The Rift, for something more than a mile after emerging from the ocean southeast of Fort Ross, lies in the Franciscan formation, and the latter is greatly

crushed and broken along it. Back of Fort Ross, the surface rocks traversed by the Rift belong to the Walalla formation, and from this point for a number of miles to the northwest no other formation appears.

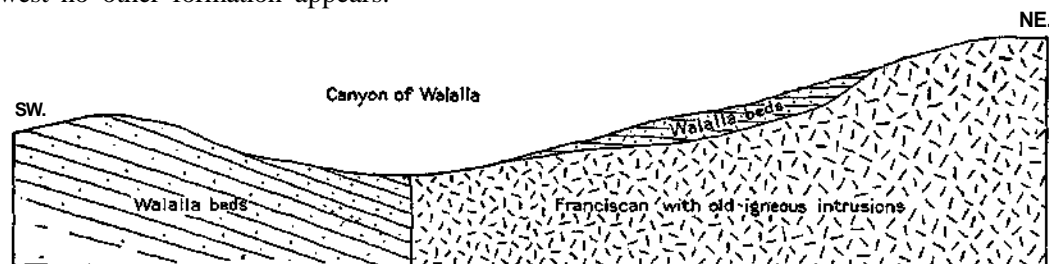

FIG. 1.—Geological section transverse to the Rift where it is followed by the Walalla (Gualala) River.

At the point where the road from Stewarts to Geyserville crosses the Gualala River, faulting and erosion have exposed the underlying Franciscan formation. This appears upon the northeast side, showing that the opposite side, that toward the ocean, has dropt. The Franciscan occupies but a narrow strip and is replaced for some distance up the ridge upon the northeast, by Walalla sandstones. These relations are shown in the cross-section sketch shown in fig. 1. Near the mouth of the Walalla River the formation upon the coast side of the Rift still appears to be the Walalla sandstones; the rocks upon the opposite side are buried under the alluvium of the valley. After leaving the valley of the Garcia River, the Rift lies wholly within the Franciscan formation until it disappears in the ocean. The Monterey shales with sandstones at their base form nearly the whole of the coastal terraced plain in the vicinity of Point Arena. They rest unconformably upon the Franciscan rocks and dip at a steep angle to the southwest. The Monterey formation nowhere appears to come in contact with the fault.

#### BODEGA HEAD TO BOLIFFAS BAY.

*General Note.* — From the point 2 miles south of Fort Ross where the Rift in its southeasterly course leaves the shore, it passes beneath the Pacific for a distance of 12 or 13 miles. Its observed course to the northwest of Fort Ross, if projected southeasterly with a slight curvature, would strike the shore again at Bodega Head; and here it is found on the low ground of the isthmus that connects the head with the mainland. The Rift here coincides in position with a fault described by Osmont,<sup>1</sup> whereby the Franciscan rocks to the east are dropt down against the pre-Franciscan dioritic rocks of the headland. Immediately to the east of the fault-trace is a marsh. Across the mouth of the bay formed by the headland is a sandspit and the fault-trace should cross the spit near its abutment upon the shore line, but the drifting sands preclude its finding an expression here in geomorphic forms.

To the south of Bodega Head the Rift follows Tomales Bay (plate 6A) to its head near Point Reyes Station. This is a remarkably linear inlet of the ocean lying between Point Reyes Peninsula and the mainland, having a length of about 15 miles and not exceeding a mile in width. It has generally been regarded as a feature determined by a fault,<sup>2</sup> the same as that noted by Osmont at Bodega Head, whereby the Franciscan rocks of the mainland were brought against the pre-Franciscan granitic and dioritic rocks of the peninsula. The bay is quite shallow, but both of the slopes above the shore line are rather precipitous, and the ridge crests on either side attain elevations of over 1,000 foot. On the mainland side of the bay there are some rather vaguely defined terraces, both in the form of wave-cut benches and delta embankments. On the same side of the bay there are marine deposits of late Pleistocene age, containing abundant molluscan remains which have been elevated to about 25 feet above sea-level, and which are the equivalent of similar deposits at a similar elevation on the east side of San Pablo Bay.

<sup>1</sup> Hull. Dept. Geol., Univ. Cal., vol. 4, No. 3.

<sup>2</sup> Cf. Anderson, Geology of Point Keyes Peninsula, Bull. Dept. Geol., Univ. Cal., vol. 2, No. 5.

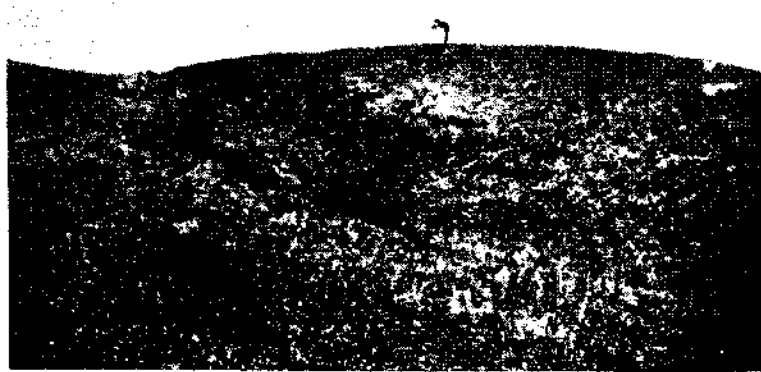

A



B



C



D

Characteristic Rift features near Fort Ross, Old scarps accentuated by new fault, Undrained ponds. F. E. M.

To the south of Tomales Bay the Rift lies in a remarkable defile with abnormal and ill-adjusted longitudinal drainage, which extends thru to Bolinas Bay, a distance of about 14 miles. On the east side of the defile is the steep coastal slope of the mainland, rising to a ridge crest from 1,000 to 1,700 feet in height. The transverse gullies in this slope are shallow, and detract but little from the general effect of a fairly regular but uneven steep slope. On the west is an even steeper but more incised and rugged slope, which forms the eastern edge of the peninsular land mass. This slope culminates in crests having an altitude of about 1,500 feet. The most striking geomorphic feature of the bottom of the defile is the presence of low ridges with intervening ravines or gullies elongated parallel to the general axis of the depression. More or less hummocky surfaces, with hillocks and hollows having no regular orientation, also occur. In the hollows ponds are fairly common features. The chief drainage is to Tomales Bay by Olema Creek, which heads within 2.5 miles of Bolinas Lagoon; and the divide between this stream and the parallel one which flows to the southeast has an altitude of about 400 feet above sea-level. The southeast end of the depression is submerged beneath sea-level, and is cut off from Bolinas Bay by a sandspit. The very shoal water inside of the sandspit is known as Bolinas Lagoon. (See plate 6B.)

The rocks on the east side of the defile belong wholly to the Franciscan series. On the west side, at the north end, we have chiefly the granitic and dioritic rocks of the peninsula with limited masses of crystalline limestone into which these rocks are intrusive. Farther south the granitic rocks are overlain by the shales of the Monterey series, and these rocks form the west side of the defile for several miles. The shales have inconstant and often very high dips. Still farther south the sandstones of the Merced series lie unconformably upon the Monterey shales, and near the town of Bolinas dip uniformly at moderately low angles toward the axis of the defile. It is thus apparent that the axis of the defile crosses more or less obliquely or transversely the contact between the Monterey and the granitic rocks, and also the contact between the Merced and the Monterey. It is also a remarkable fact that altho on the east side of the defile the Franciscan rocks constitute the mountain mass to a thickness of several thousand feet, this entire series, together with the Knoxville, Chico, Martinez, and Tejon, is almost entirely absent between the Monterey and the granitic rocks on the peninsula in the immediate vicinity. This indicates clearly that in pre-Monterey time the peninsular mass had been uplifted on a fault along the present coastal scarp, so that the granite was brought against the Franciscan and denuded of its unconformable mantle of sedimentary strata before it was submerged to receive the deposits of Monterey time. It is also clear that inasmuch as there is a great volume of Monterey shales on the peninsular or seaward side of this fault line, and no trace of the same formation on the mainland to the east of the fault line, one of two things must have happened. Either the submergence which permitted the deposition of the Monterey shales was confined to the peninsula and was effected by a downthrow of that block on the same fault as that upon which it had earlier been upthrust, so that there was no sea over the territory east of the fault; or, if the regions on both sides of the fault were submerged together, then in post-Monterey time the east side of the fault was lifted into the zone of erosion and denuded of its covering of Monterey shales so thoroly that no trace of them now remains. There is no escape from one or the other of these conclusions, and each of them involves a movement on the fault with relative downthrow on the southwest side, or the reverse of that which occurred in earlier, pre-Monterey time. From this interpretation it follows that the defile extending from Tomales Bay to Bolinas Bay lies along the trace of a fault which dates from pre-Miocene time, and that upon this fault there have been large movements in opposite directions so far as the vertical component of such movements is concerned. The trace of this ancient fault is also the line of the modern Rift.

The dip of the Merced beds at Bolinas toward the Franciscan rocks of the mainland is quite analogous to the dip of the same beds toward the Franciscan of San Bruno Mountain on the San Francisco Peninsula,<sup>1</sup> and has the same significance, viz., that the Merced beds have been relatively downthrown on the west against the older rocks. The fault in the Tomales-Bolinas defile has usually been regarded as identical with and a continuation of the San Bruno fault of San Francisco Peninsula, and there seems to be no good reason for changing this judgment, altho, as will appear shortly, the modern Rift to the south of the Golden Gate does not coincide with the trace of the San Bruno fault, but leaves it at a small angle and pursues a course nearly parallel, but to the southwest of it. It is noteworthy, also, that while on the Point Reyes Peninsula, particularly in the vicinity of Bolinas, there is a magnificent wave-cut terrace at an altitude of about 300 feet, with a width of 1 to 1.5 miles between the base of its sea-cliff and the brink of the present sea-cliff, no such feature is to be found on the landward side of the fault-line on the coastal scarp between Bolinas Lagoon and the Golden Gate.

*Characteristics of the Rift* (G. K. Gilbert, pp. 30-35).— In a broad sense the structural trough in which lie the two bays is a feature of the great Rift. In a narrower sense the Rift follows the lowest line of the trough, controlling the topography of a belt averaging 0.75 mile in width. The physiographic habit of the trough is that of a depression occasioned by faulting. It is remarkably straight. One wall, the southwestern, is comparatively steep; the other is comparatively gentle. The gentler slope is an inclined plateau with incised drainage. Viewing the trough from any commanding eminence, the physiographer readily frames a working hypothesis of faulting and tilting. He sees in the southwestern wall a fault-scarp of moderate freshness, and in the northwestern wall a slope originally less steep, in which erosion has been stimulated by uplift and tilting. The general facts of the geology of the district, as worked out by Anderson/ agree with this theory. The axial line of the valley is recognized by him as the locus of a fault, or fault-zone, and the rocks of the southwest wall are everywhere older than those which adjoin them at the base of the opposite slope. The gentler slope is well shown by plate 7A. Plates 8B and 41B also show something of the gentler slope, and plate 7B of the bolder.

In a general way the two slopes are drained by streams which descend to the axis of the valley, and are there gathered in two longitudinal trunk streams which flow severally to Tomales Bay and Bolinas Lagoon; but in a central belt following the lowest part of the trough the details of drainage are comparatively complex, and their complexity is associated with peculiarities of the relief which serve to distinguish the central belt from the bordering slopes. In the bordering slopes the subordinate ridges conform in normal manner to the drainage, having evidently been developed by the erosion of the canyons which separate them. In the axial belt the ridges are evidently independent of the drainage, often running athwart the courses which would normally be followed by the drainage. In part the ridges divert or control the drainage; in part the drainage traverses and interrupts the ridges.

The influence of the ridges on the drainage is illustrated by the accompanying diagrams. Fig. 2 shows the actual drainage system; fig. 3 the system which would be developed if there were no special conditions along the axial zone. The small ridges of the axial zone trend parallel to the axis, and their interference gives parallel courses to various streams which would otherwise unite. The influence of the drainage on the ridges is illustrated by fig. 4, which shows a small ridge resting on the side slope of a larger ridge. The drainage of the larger ridge breaks thru the smaller, making gaps. Plate 7B shows the slope of a greater ridge at the right; and at the left two bushy hills

<sup>1</sup> Cf. A Sketch of the Geology of the San Francisco Peninsula. U. S. G. S., 15th annual report.

<sup>8</sup> Geology of Point Reyes Peninsula, by F. M. Anderson. Bull. Dept. Geol., Univ. Cal., vol. 2, No. 5.

which are part of a flanking ridge dissected by cross-drainage. The flanking ridge appears also in the distance. In plate 8A the flanking ridge is broader; in plate 9A it is more nearly a terrace than a ridge.

Similar relations between ridges and drainage lines are found in regions of steeply inclined strata, each ridge being determined by the outcrop of a resistant formation, or at least all of the preceding description might apply to the topography of such a region; but other characters remain to be mentioned, and these serve for discrimination.

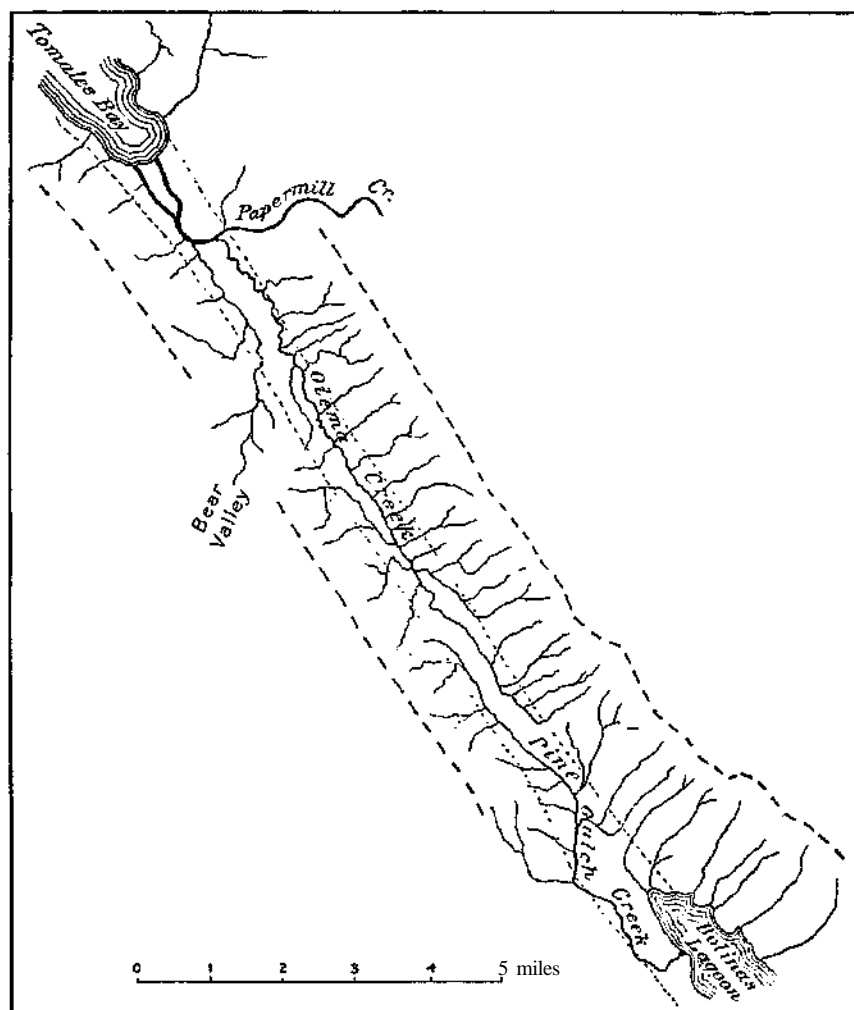

FIG. 2.—Drainage map of Bolinas-Tnmales Valley. Heavy broken lines show crests of bounding ridges. Light broken lines indicate limits of Rift topography.

Where a steep-sided ridge is determined by the presence of a resistant formation, the determining rock follows and usually outcrops along its crest; but in the ridges under consideration there are few rock outcrops, and such as occur are not systematically related to the crest lines. The formation of the crest is not always the same thru the whole length of the ridge, and it is not always a rock of such character as to resist erosion. Between the ridges are linear valleys, and many of these are occupied by streams, but in a number of instances they are crost by the drainage. Often they include local depressions, with ponds or small swamps, this character being so pronounced that forty-seven such ponds were seen between Papermill Creek and Bolinas Lagoon, a distance of 11



miles. (See plates 9B, 10, 43, 54A.) The valleys range in width from 20 or 30 feet to about 500 feet, the majority falling between 100 and 200 feet; and each of them is approximately uniform in width, unless occupied by a stream. In a typical cross-profile, the side of the valley is somewhat definitely distinguished from the bottom by a change of slope (see fig. 5), the distinction appearing at one or both sides.

In view of these characters, and especially of the abundance of ponds, it is evident that these little valleys are not products of stream erosion; and that in so far as they are occupied by streams the streams are adventitious. Their true explanation is suggested by their relation to certain of the earthquake phenomena of April, 1906. As will

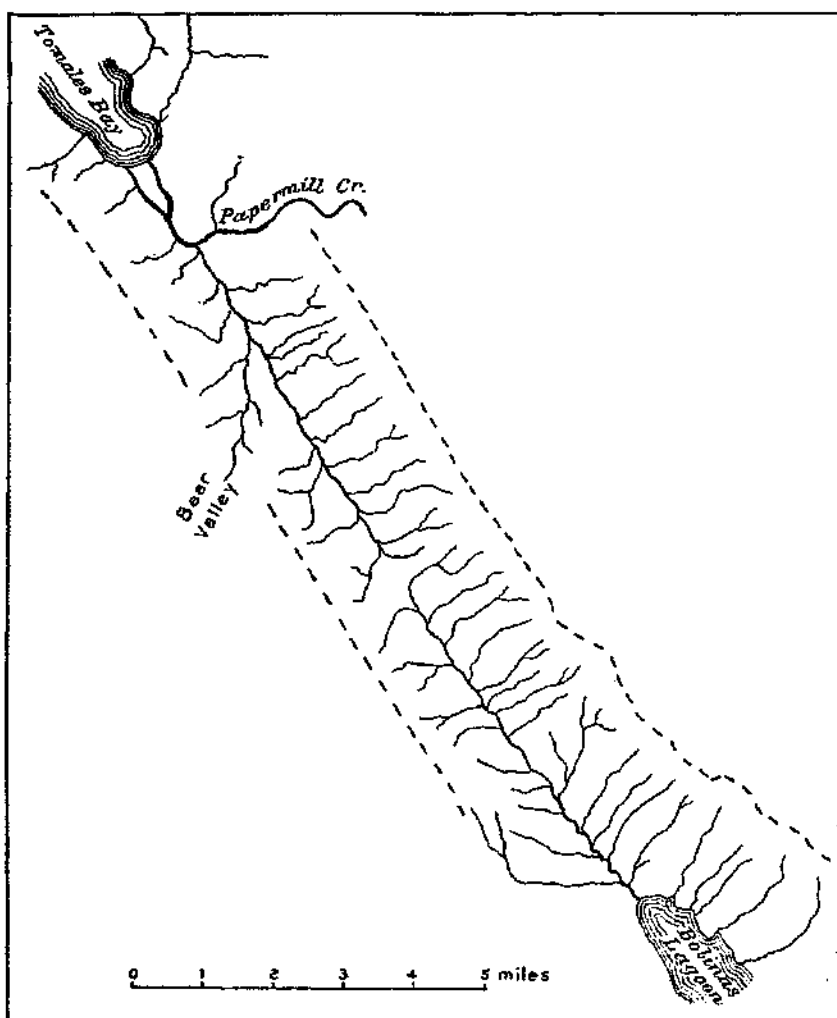

FIG. 3.—Hypothetic drainage map of Bolinas-Tomales Valley, if developed without influence of Rift displacement. Compare fig. 2.

presently be described in detail, the trace of the earthquake fault thru the greater part of its course in the larger valley follows the edge of one or another of these small valleys; and in places where the fault movement included vertical dislocation, such dislocation nearly always tended to increase the depth of the valley. (See plate 10B and fig. 6.) Of the numerous minor or secondary cracks developed by the earthquake in the immediate vicinity of the main fault, a considerable proportion occurred at the edges of the *Yitth*\* valleys, following more or less closely the line along which the bottom meets the side; and with these cracks also there was usually a little vertical dislocation, the ground



A. Looking down Tomales Bay from near Olema. H.W.F.



B. Looking down Bolinw Lagoon and Bay toward the Golden Gate. ViUage of Boli\_n« » foregromd. H.W.F.



A. Looking north in the Bolinas-Tomales Valley. G. K. &

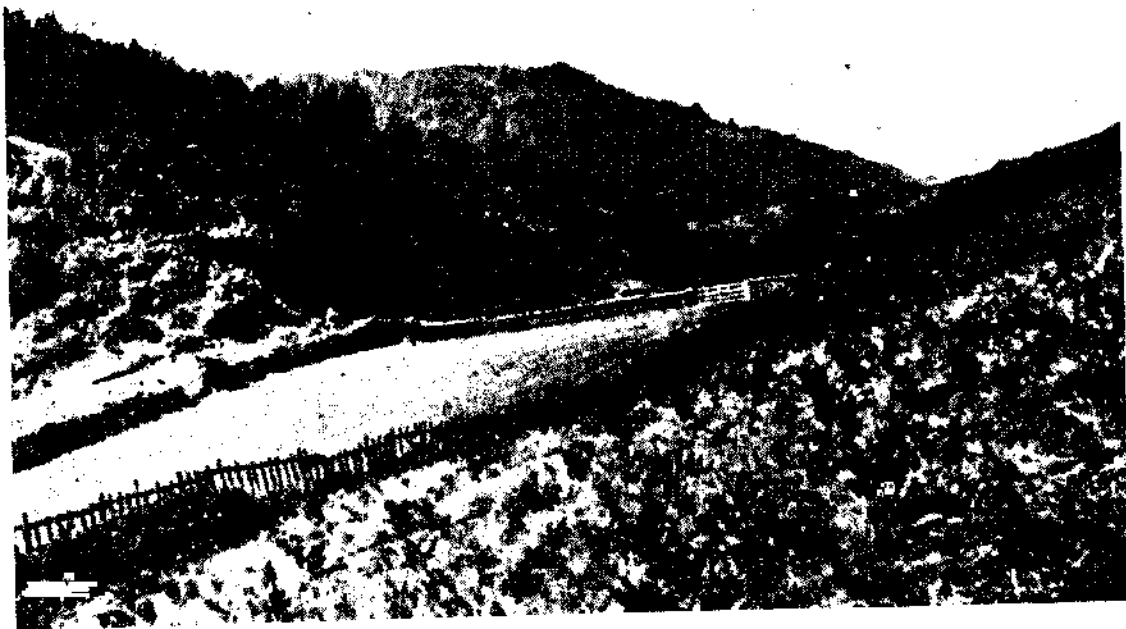

B. Fault-sag and side-Mil ridge near Boadietti's ranch. The fault-trace follows sag and appears, at left of field. O.K.O.

sinking a few inches on the side toward the middle of the valley. Thus the surface changes associated with the earthquake tended, within this belt, to increase the differentiation of the land into ridges and valleys; and it is easy to understand that the inception as well as the perpetuation of the ridges and valleys was due to faulting.

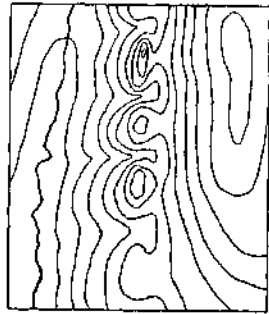

FIG. 4.—Map of side-hill ridge.

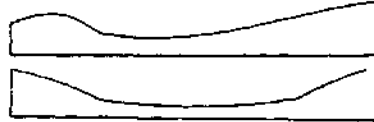

FIG. 5.—Cross-profiles of fault-sags.

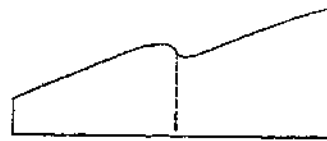

FIG. 6.—Cross-profile of side-hill sag shown in plates 7B and 10B.

Collectively these ridges and valleys occupy a belt from 0.5 to 1 mile in width, and constitute the local development of the Rift, using that term in its narrower sense. They make up the entire surface of the belt, except where overpowered by some vigorous creek. The individual ridges are not of great length, being 2 or 3 miles at the most, and usually much less. Some of them end by wedging out, others by dropping down until replaced in the same line of trend by valleys. Their greatest height above base, except where the adjacent valleys have been deepened by erosion, is about 150 feet. The narrower have straight, acute crests; the broader have undulating backs with more diversity of form than is shown by the associated valleys. Some are crossed by curved or straight depressions, and these depressions have all the characters of the parallel valleys, including the association of earthquake cracks.

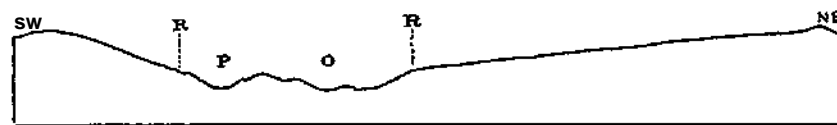

FIG. 7.—Cross-profile of Bolinas-Tomales Valley. Vertical and horizontal scales the same. RR = limits of Rift. P = valley of Pine Gukh Creek running SE. O = valley of Olema Creek running NW.

In the remainder of this report the term Rift will be applied only to the narrow belt just described. Regarding it as the surface expression of a great shear zone or compound fault, the ridges are the tops of minor earth-blocks, and the valleys are in part the tops of relatively depressed blocks and in part depressions resulting from the weathering of crushed rock. Considering the Rift as a physiographic type, I find it convenient to have a specific name for one of its elements, the small valley; and in some of the descriptions which follow I shall speak of it as a *fault-sag*. (See plates 7B, 8A, and 11.)

The general relation of the Rift to the greater valley is illustrated by the cross-profile in fig. 7. Along its northeastern side it everywhere lies lower than the adjacent slope of the greater valley, the produced profile of the valley slope passing above the fault-ridges as well as the fault-sags. Along its southwestern side some of the fault-ridges appear to project above the restored profile of the greater valley, while the fault-sags lie below. If I interpret the structure correctly, the great compound fault concerned in the making of the valley trough — a fault of which the vertical dislocation amounts to several thousand feet — includes a certain amount of step-faulting, which



FIG. a.—Ideal section across Rift corresponding to profile in fig. 7.

is responsible for some of the western ridges of the Rift belt; but with that exception, the ridges and sags of the Rift are occasioned by the unequal settling of small crust blocks along a magnified shear zone. (Fig. 8.)

The limits of the Rift are not definite. The boundaries drawn in fig. 2 serve to indicate the belt in which the Rift structure dominates the topography, but do not indicate the limits of the Rift structure. Within the belt the dislocations have been so re-

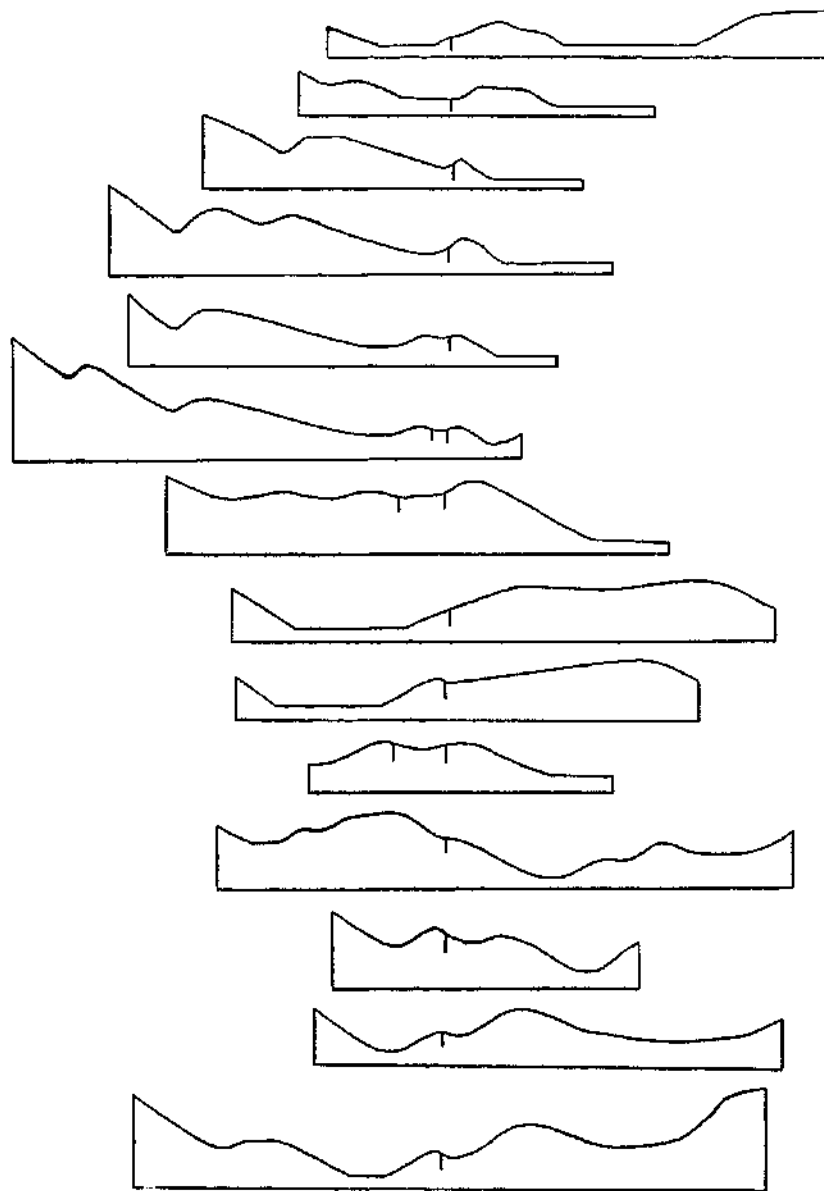
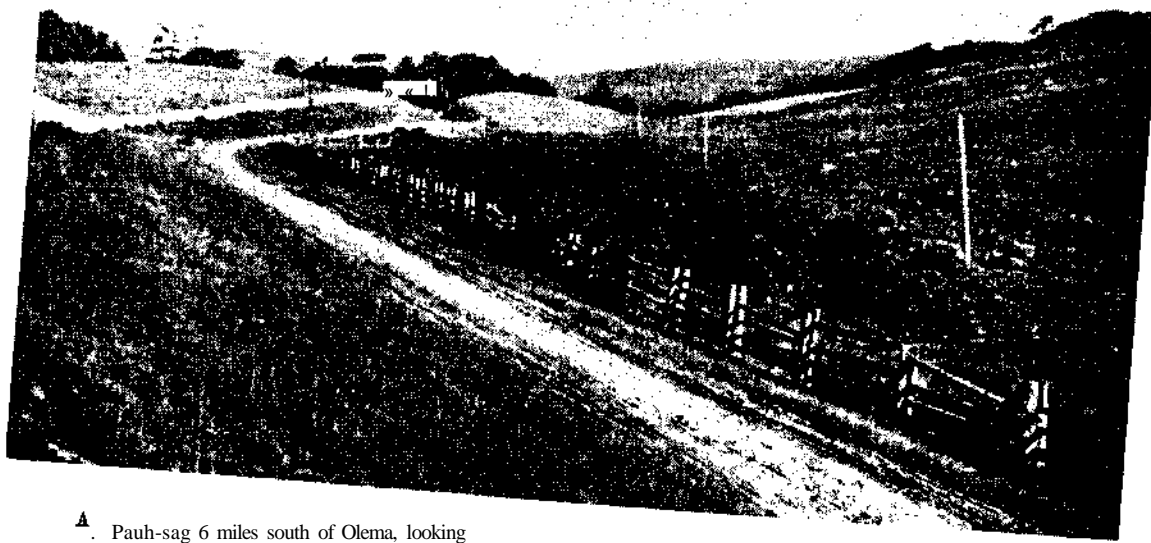

FIG. 9.—Cross-profiles of the Rift arranged in geographical order with the most northerly at top and northeast ends at the right. Positions of fault-trace and its branches are indicated. The profiles are copied from field sketches made without measurement.

cent and of such amount as to keep ahead of weathering and erosion, so that their expression has been little dimmed by the processes of aqueous sculpture. Outside the belt the evidences of recent dislocation are less striking, but nevertheless exist. The inter-stream ridges of the northeastern slope are here and there indented and creased in such a way as to indicate recent faults of small amount trending parallel to the Rift. In the vicinity



A. Pauh-sag 6 miles south of Olema, looking northwest. The drainage crosses the sag from right to left, *Q.Z.G.*



B. Side-hill ridge 4 miles south of Olema, looking northwest.



A. Side-hill ridge *i* miles south of Olema, looking southeast. G. K. Q.



B. Eift tepsgraphy, with pond, a mij« \$mtk ef OS«a, lookiag seatleagt. Q. K. G.



A. Eift topography, with pond, near Bondietti's ranch, looking southeast. G. K. G.



B. The fault-trace near Bondietti's ranch, looking west. Ilkitrafes the aisociatios of Tertical displacement with faait-sags aad ponds. G. K. Gh



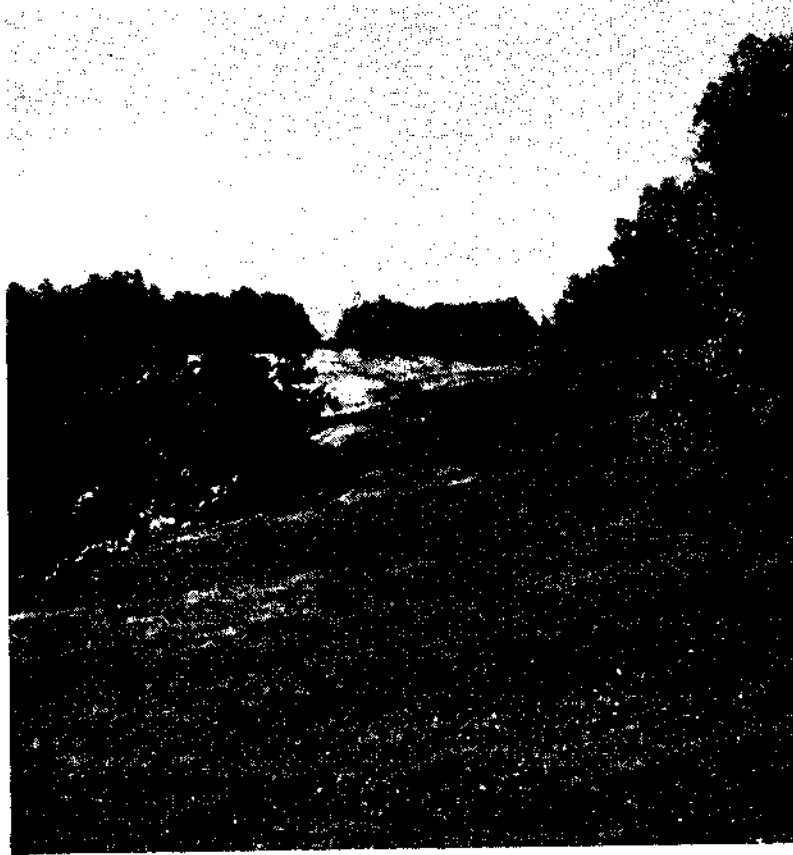

A. Fault-sag 2 miles south of Olema, looking southeast. G. K. G.

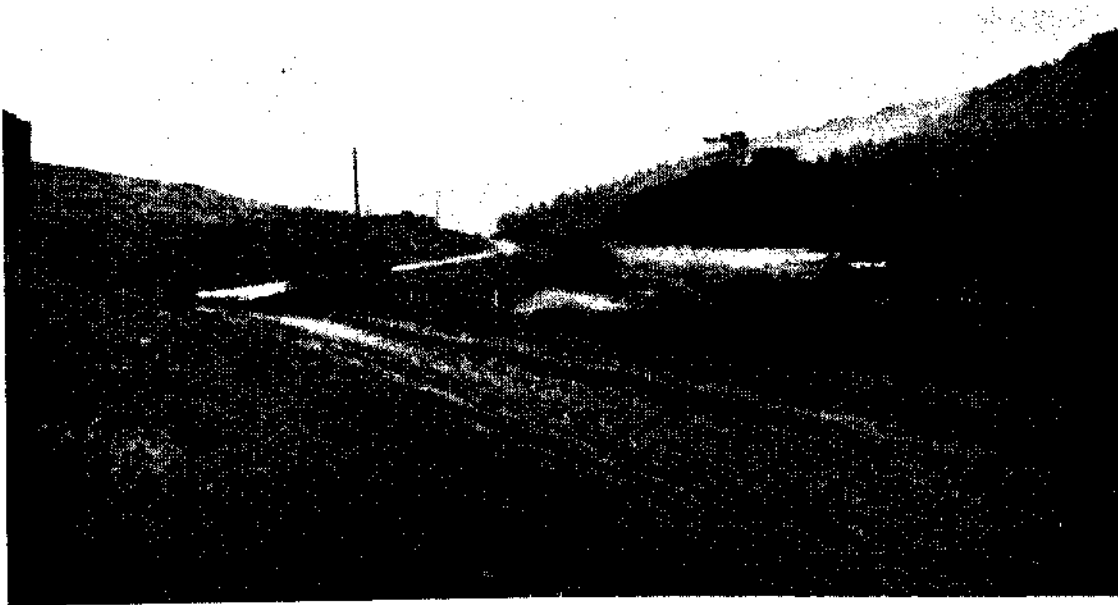

B. Fault-sag 3 miles south of Olema, looking southeast. G. K. G.

of both Bolinas Lagoon and Tomales Bay such features grade into dislocation terraces of greater magnitude, which originated at earlier dates but may have been recently accentuated. There are also narrow terraces of displacement on the comparatively steep face of the ridge southwest of the Rift, and at two points there are minor crests and associated canyons parallel to the main crest and to the Rift. So little is known of the local details of geologic structure that a different explanation of these creases, terraces, and spurs is not altogether barred; but their physiographic relation to the Rift features is so intimate as to leave little question in my mind of their genetic similarity. Assuming that they are correctly explained as the product of minor faulting of only moderate antiquity, they serve to connect the great trough containing the bays with the narrow belt of peculiar and striking topography, and indicate these as parts of a single great phenomenon — a belt which has been the locus of complicated fissuring and dislocation during the later geologic epochs.

#### MUSSEL ROCK TO PAJARO RIVER.

From Bolinas to the vicinity of Mussel Rock, about 8 miles south of the Golden Gate, the course of the Rift is beneath the waters of the Pacific, across the bar in front of the entrance to the harbor. Near Mussel Rock it intersects the shore at a great landslide (plate 12A) in rocks of the Merced series. At Mussel Rock, the basal beds of the Merced series rest directly upon an old land surface of worn-down Mesozoic rocks, and the basal bed contains abundant cones of *Pinus insignis* resting upon cemented alluvium. The cone-bearing bed immediately underlies marine strata and numerous fossils occur near the base of the series at the top of the ridge. The Merced strata here have a dip of about 15° to the northeast. The contact between the Merced and the older rocks trends southeast across the peninsula; and for some miles the Rift is approximately coincident with the trace of the contact and, for some portions of this distance, exactly so. From the shore line the course of the Rift is the same as that of the steep cliffs which rise at the back of the Mussel Rock slide to an altitude of over 700 feet. From the top of these cliffs, at an elevation of about 500 feet above sea-level, the course of the Rift as far as San Andreas Lake is marked by a line of shallow longitudinal depressions, ponds, and low scarps. (See plate 12B, 13, and 14.) There are eight ponds in this stretch of about 4.5 miles. This portion of the modern Rift was recognized as such in 1893.<sup>1</sup>

At a point about 4 miles from the Mussel Rock slide, the longitudinal depression which marks the course of the Rift becomes much more pronounced and passes into a remarkably straight and deeply trenched valley, the greater part of which has been converted by large dams into the San Andreas and Crystal Springs Lakes, used as reservoirs by the Spring Valley Water Company as water supply for the city of San Francisco. This straight valley (see plate No. 15) has an extent of 15 miles with a steady course of S. 34° E. to a flat divide southwest of Redwood City, whereby one passes over into the end of a similar but less pronounced valley, in which are situated Woodside and Portola. The San Andreas and Crystal Springs Lakes valley is almost wholly in the Franciscan terrane and the axis of the valley is discordant with the structural lines and contact planes of its constituent formations and intrusive masses. At the upper end of San Andreas Lake, however, the southwest edge of the Merced terrane forms in part the boundary of the valley on the northeast side for a short distance. The valley as a geomorphic feature (plate 16A) dates back fairly well into the Pleistocene. It is drained

<sup>1</sup> "The line of demarkation between the Pliocene and the Mesozoic rocks, which extends from Mussel Rock southeastward, is in part also the trace of a post-Pliocene fault. The great slide on the north side of Mussel Rock is near the land terminus of this fault-zone, where it intersects the shore line. Movement on this fault-zone is still in progress. A series of depressions or sinks, occupied by ponds, marks its course. Modern fault-scarps in the Pliocene terrane are features of the country traversed by it." The Post-Pliocene Diastrophism of the Coast of Southern California, by Andrew C. Lawson, Hull. Dept. Geol., Univ. Cal., vol. 1, No. 4, pp. 15U-151.

by San Mateo Creek which flows in a sharp gorge thru the wider part of the broad, flat-topped ridge which separates the valley from the Bay of San Francisco. This stream is regarded as a relic of the original consequent drainage of the northeast slope of Montara Mountain, which became superimposed upon the Franciscan terrane by the denudation of the overlying soft and little coherent Merced formations. From this consequent trunk the valley in which San Andreas and Crystal Springs Lakes now lie was evolved by subsequent erosion along the line of the Rift, its present features dating from a period in the Pleistocene later than the removal of the Merced formations. A small portion of the upper end of the valley has been captured by the headwater erosion of San Bruno Creek.

To the southeast of Crystal Springs Lake, the valley followed thus far bifurcates about 2 miles beyond the lake, on either side of a median ridge. The two branches are nearly parallel. The east branch rises to a wide and rather flat divide, with streams heading in it from both sides. The other branch, altho it is more incisive, has no well-defined stream, but has a small swamp at its lower end. It rises to a sharper divide, from which there is a descent into the narrow straight canyon of West Union Creek. It is this western depression that the Rift follows. Near Woodside the canyon of West Union Creek expands into a more open valley, with steep mountains on the southwest and lower hills on the northeast. The Rift follows this straight valley (plate 16B) to its southeastern end, and then ascends to the saddle which separates Black Mountain from the mountains to the west. From this saddle it descends to the narrow canyon of Stevens Creek. It crosses the canyon at a small angle near its upper end and parallels the creek on the southwestern side, at an elevation of about 500 feet above it. It then passes thru the saddle between Stevens Creek Canyon and Congress Springs, and keeps well up on the slopes to the west of Congress Springs behind a series of shoulders and knolls to a reservoir on a saddle thru which it passes. From this saddle southeastward the line of the Rift again lies along the southwest side of a longitudinal valley and so continues on a line independent of the present drainage to the pronounced notch in the crest line of the range at Wright Station.

In this stretch of the Rift from Crystal Springs to Wright, the coincidence of the Rift with the major geomorphic features is very striking for the first half of the distance. In the second half, if we judge by the fault-trace, it appears to be quite independent of, tho parallel to, the canyons; and its only manifest relationship to the geomorphic features is its coincidence with a series of saddles or windgaps in the transverse spurs of the mountains. Its general parallelism with, and proximity to, the crest of the range thruout the entire stretch is pronounced. In the notch at Wright, the Rift intersects the crest line and passes from the northeastern flank of the range to the southwestern.

The general features of the Rift from Wright to Chittenden are described by Mr. E. S. Larsen in the following note:

From the hills above Wright Station to the village of Burrell, a distance of about 2 miles, the Rift follows along the ridge above Los Gatos Creek, which drains to the east. The drainage of the western slope of the ridge is to the Pacific. For most of this distance the Rift is a short distance on the Los Gatos Creek side. It usually occupies a small, trough-like depression; or, where it cuts just above the heads of the small gullies, there are low, rounded knolls between the gullies. These knolls are seldom over 30 feet higher than the trough. Just southeast of Burrell, the Rift traverses the ridge and follows a gully into Burrell Creek, which it crosses. It continues in a southeasterly direction, parallel to the creek and about halfway up the ridge to the southwest of it. The elevation of the ridge is only about 400 or 500 feet above the creek bed, and the top is rounded, with a steep slope below this to the Rift, and a gentle slope below the Rift

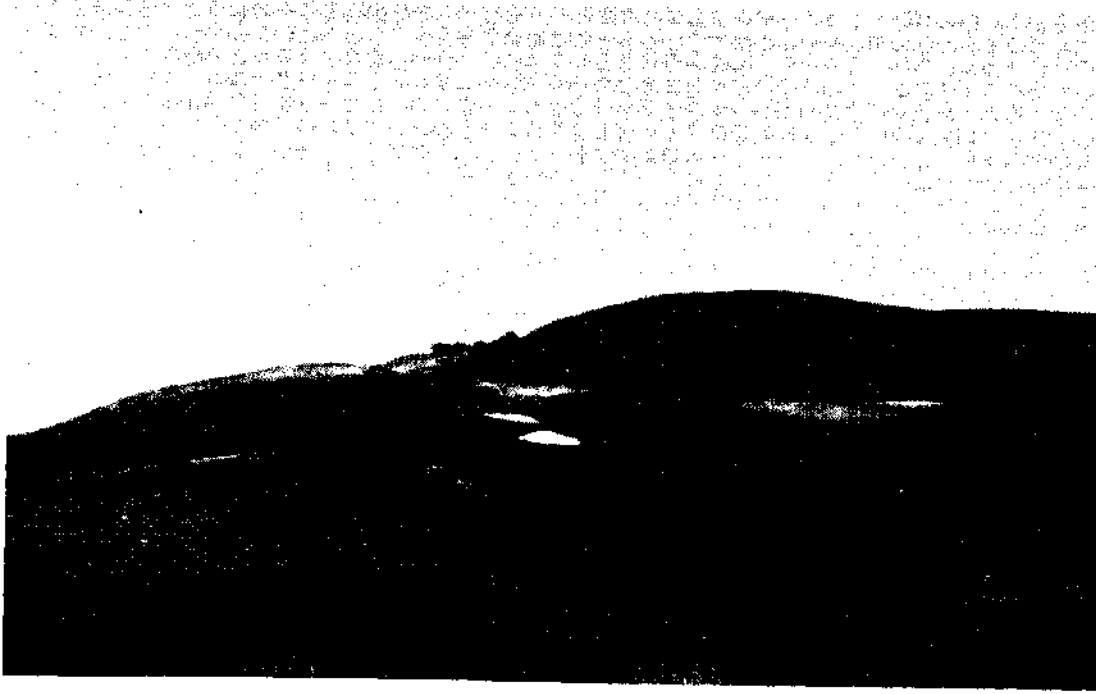

A. Great landslide at Mussel Eook, where the Eift enters the Ooast from the Paiofio. H. O. W.

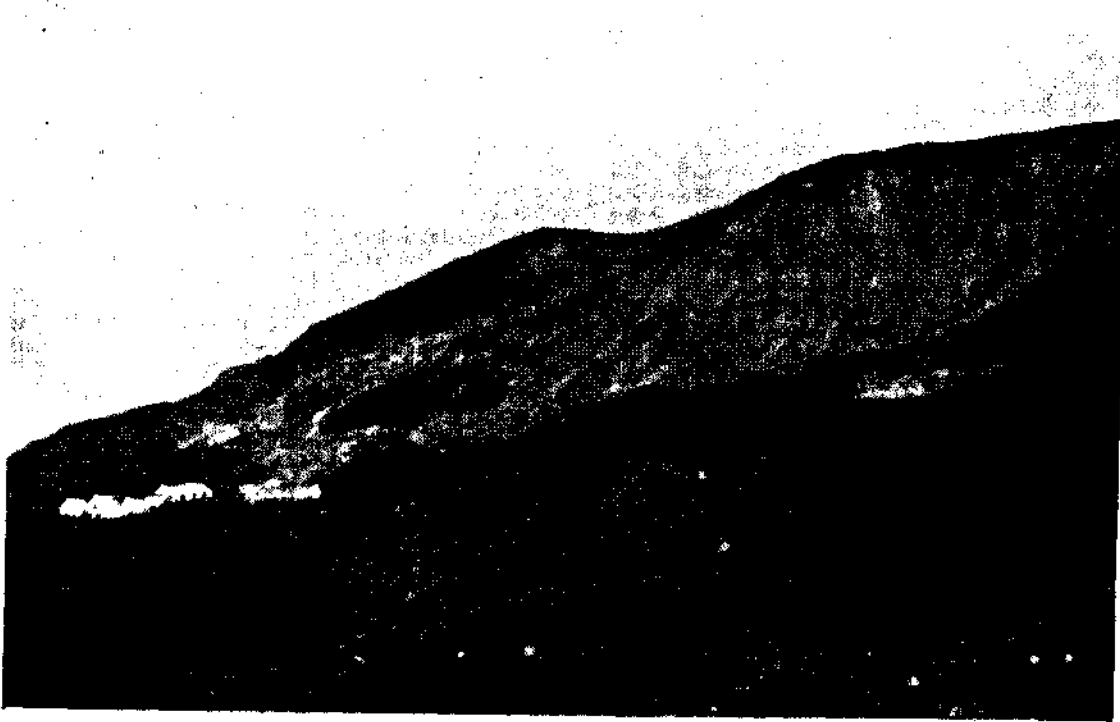

B. Looking northwest along the Eift. The iandalide is jwtt beyond the bonne, H. O. W.

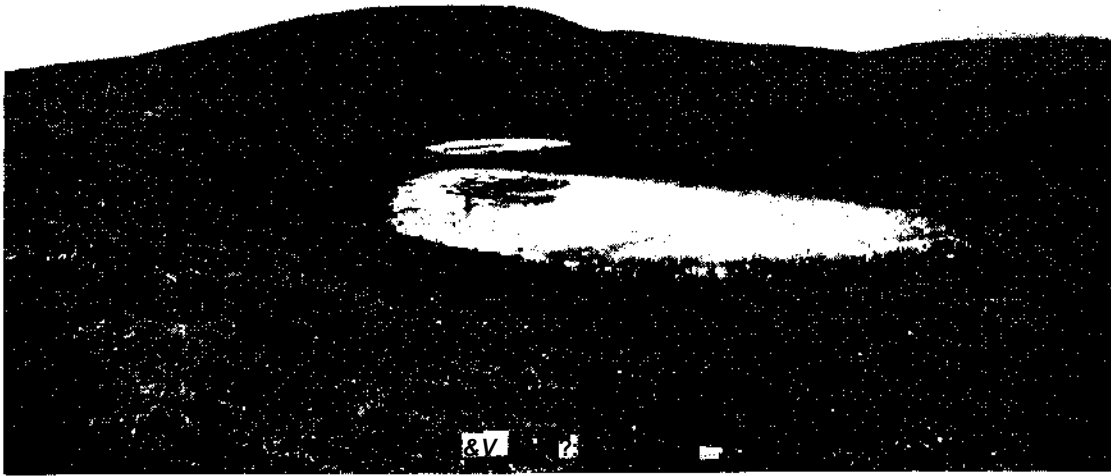

A



B

Characteristic ponds along the Eift soatht«t of Mass«l Bock. H. O. W.



A



C



B



D

Features of the Rift between Mussel Rock and San Andreas Lake, H. O. W.

to the creek. Near Burrell the slope is very gentle at the Rift, for from 20 to 50 feet, but is steep above and below. Looking up the Rift and the creek from this point, one gets the impression of a long straight creek, but in reality the view is over the divide, down a small tributary of Soquelle Creek to its junction with the main stream and thence up the main Soquelle Creek. About 2.5 miles from Burrell the Rift follows a small gully into Soquelle Creek, which it crosses where the creek makes a sharp turn to the west. For the next 4 miles, or to the point where the new county road crosses the divide between a branch of Soquelle Creek and Eureka Creek, it follows near the top of the timbered ridge to the southwest of Soquelle Creek. The heavy timber obscures the topography, but the Rift, wherever crossed, is marked by a bench or trough on the hillside.

Following the Rift to the southeast, it passes at the divide into the head of Eureka Canyon, rises on the northeast bank, and slowly gets farther away from the creek, cutting across the tributary creeks and rarely following one of the smaller gulches for a short distance. The typical section here gives a steep slope on the high hills to the northeast, then about 0.25 mile of gently sloping, rolling hills, and finally the steep slope to the creek itself. The Rift is on the gentle slope, generally at some distance from either of the changes in slope. This continues for about a distance of 2 miles on to Grizzly Flat. Here the high steep hills to the northeast are separated from the lower hills to the southwest by a flat about 500 feet across. The Rift is on this flat near its center, and usually marks the northeast boundary of a series of low knolls. It continues on the flat for about 0.5 mile to where the hills close together and leave a rather steep-walled gulch. The Rift follows up this gulch for about a mile, and then crosses into the head of another creek, which it follows down for about 3 miles, where the stream turns sharply to the north. For the upper mile the gulch is rather sharp and deep, but at Hazel Dell the hills on both sides are low and rolling, while the lower mile is again rather steep, opening at the turn to a rather flat country. At Hazel Dell and other points, the Rift occupies a small but distinct trough very near the southwest bank of the creek. From here to Chittenden, a distance of about 8 miles, it follows parallel to Pajaro Valley, well up on the hills, and cuts across the canyons at almost right angles.

The typical section up one of these ridges gives a gentle slope from the valley to an elevation of about 1,000 feet; a steep slope for about 50 feet in the opposite direction, which marks the Rift; a very gentle slope for about 1,000 feet across; and finally, the steep upper slope of the hills. Over this area the Rift is nearly always marked by a trough, which often gives rise to a small lake perched on a ridge between two steep canyons. At a few points, especially about a mile northwest of Chittenden, small streams and gullies tend to follow the Rift, and they then make a sharp turn where they leave it. At Chittenden the Rift again passes thru a pronounced notch in the crest of the range occupied by the canyon of Pajaro River (plate 17A), from the western flank of the dominant ridge of the Santa Cruz Range to the eastern flank of the Gavilan Range.

The rocks traversed by the Rift from Mussel Rock to Pajaro River are, so far as known, almost wholly confined to the Franciscan and Monterey series, the former prevailing in the northern part and the latter occurring only in the southern. At Pajaro River the Rift encounters the granitic rocks of the Gavilan Range, but these lie wholly on its western side.

## PAJARO RIVER TO THE NORTH END OF THE COLORADO DESERT.

BY H. W. FAIRBANKS.

The earthquake of April 18, 1906, opened and displaced the walls of the old fault along the Rift as far south as the town of San Juan in San Benito County. The fault-trace passes directly under the western span of the Southern Pacific Railroad bridge across San Juan River, as shown by the displacement of the piers at the end of the bridge, a distance of 3.5 feet. For a distance of nearly half a mile on either side of the bridge, the river has established itself in the Rift. To the northwest the steep slopes of Mount Pajaro facing the canyon do not show any regular fissure. This does not, however, indicate any discontinuity in the fault, for the surface of the whole mountain is more or less broken by auxiliary cracks, secondary fissures, and slides.

Southeast over the hills from the point where the Rift leaves the river, the characteristic features of the Rift make their appearance. It is marked by a small pond (plate 17B), springs, and a more or less continuous ridge with its steeper face toward the southwest. The fissure of the recent earthquake follows this series of features (plate 18A), and, at a point halfway between the bridge and San Juan, there is shown in a broken fence a horizontal displacement of 4 feet. A mile before reaching San Juan, granitic rocks are exposed upon the southwest side of the Rift. Shortly beyond this point the Rift leaves the hills and traverses the western edge of the valley of the San Benito River. The ridge which we have been following is now lost in the level floor of the valley, but as far as traceable its course is directly toward the low bluff upon the eastern edge of the town of San Juan. The fissure of the recent earthquake is to be seen where it crosses the road 0.5 mile northwest of San Juan, but has not been noted farther along the old Rift line. It appears to bend more easterly, and this probably connects it with the disturbances of the earth between Hollister and San Juan. Mr. Abbe, of San Juan, states that the earthquake of 1890 opened the old Rift and that the displacement of the walls, tho small, was in the same direction as in the recent earthquake.

The town of San Juan stands upon a bench of gravel which dips gently in a southwesterly direction, but upon its northeastern side presents a steep face which, near the old mission, has a height of about 50 feet. This bluff is marked thruout its length of 0.5 mile by several springs; and there can be little doubt that it owes its existence to a fault movement uplifting and tilting toward the southwest a portion of the floor of the valley, and that it thus originated in the same way as other similar features which we shall find to be characteristic of the Rift. The Rift leaves the valley southeast of San Juan and gradually rises along the eastern slope of the Gavilan Range. It intersects the head of San Juan Canyon, and has here given rise to an interesting modification of the drainage. San Juan Canyon is long and narrow and is formed by the union of several small streams which, rising upon the higher slopes of the range, pursue a normal course toward the San Benito Valley, until reaching the Rift, they turn northwest and slightly away from the fracture line, giving rise to San Juan Canyon. At the point where the Rift intersects the canyon, the narrow ridge between the canyon and the valley has been broken thru, and the whole drainage passes directly down the mountain, abandoning the canyon, which is now filling with delwis fan material.

For about 10 miles southeast from the head of San Juan Canyon, the Rift follows the eastern slope of the Gavilan Range. It is marked by small valleys and gulches, by hollows and ridges upon whose sides oak trees are growing; and it is followed almost continuously by a wagon road. One of the most interesting features along this portion of the Rift is Green Valley, a broad cienega due to the filling up with gravels and silt of a valley lying close under the steeper portion of the Gavilan Range. There are two fault-lines below the valley and about 0.25 mile apart. The cienega is due to vertical







A. The Eift valley between San Andreas lake and Crystal Springs, looking southwest. ^It-trace parallel to fence about 50 feet beyond. Auxiliary cracks in the foreground at an angle of 40° with it. J. U. B.



B. The Eift *mlhj* 5 milei west of Stanford Unirenty. Faalt-traoe in fowground. Per J. O.B.



A. The Eift followed by tie Pajaro River at Ohittenden, Dislocated bridge supported by false work. H.W. F.



B. The Eift a mile soatheast of CiitteadsE, Poad oa apper slope of hill. H. V. F.

displacement along the upper line, which has raised a ridge of the old crystalline rocks across the valley. This dam must first have given rise to a lake, but as this filled up with the wash brought down from the mountains, a marshy meadow took its place. The oldest resident in the district says that the earthquake of 1868 formed a small lake in the lower portion of the cienega. The great body of gravels filling the old valley acts as an important reservoir of water. The city of Hollister has taken advantage of this fact to secure a water supply. By tunneling thru the rock barrier, the gravels are reached and the water led away in pipes.

The Rift comes out upon the San Benito River 4 miles above Paicenes P.O. For several miles up the river from this point, the Rift line is masked by the recent flood plain. Above Mulberry P.O., and just before coming to the bridge across the river, a most striking and interesting feature appears. Upon the east side of the river, and separated from it by a ridge, is a narrow depression half a mile long and 75 feet deep, without any external drainage. The ridge between it and the river extends a mile northwest of the sink, and presents a steep face to the northeast. The road passes along the eastern base of the ridge and opposite the sink makes use of its even crest. The river makes a sharp bend at the bridge, and the Rift crosses to the west side. Faulting has here brought to the surface, upon the west side of the Rift, limestones associated with the crystalline schists and granitic rocks of the Gavilan Range.

In order to follow the Rift beyond the mouth of Willow Creek, we leave the San Benito River road at the mouth of the creek and follow to its head a long narrow canyon which has evidently been eroded on the line of fracture. At the head of the canyon we come out upon a bit of open rolling country which, but for a low ridge, would drain into the San Benito. This ridge has evidently been raised along the Rift, diverting a stream which would naturally be tributary to the San Benito, so that now it forms the head of Bear Creek and flows down past the Chelone peaks into the Salinas River. Several undrained hollows (plate 18B) mark the Rift as it follows the ridge between Bear Valley and San Benito River. The formation of both walls is probably of Tertiary age up to a point near San Benito P.O., where the Franciscan series constitutes the southwest side and the Tertiary the northeast. South of San Benito P.O., there is a considerable area where the surface has been much changed as a result of some one of the movements along the old Rift. A fertile valley, perhaps 0.5 mile long, appears to have been formed thru subsidence, while on the southwest is an abrupt ridge 200 feet high and fully a mile long. The ridge without doubt has been produced by faulting. Its abrupt northeastern face and long, gentle, southwesterly slope suggest in a remarkable manner the great fault blocks of the west, such as the Sierra Nevada Range. The ridge gradually sinks in a southeasterly direction, blending with Dry Lake Valley. The latter is about 2 miles across and has no external drainage. The fault-scarp already mentioned extends as a low ridge part way across the valley and is utilized by the road.

Looking southeast across the valley in the direction which the Rift pursues, a mountain is seen which seems to have been sharply cut off. Descending a narrow valley to the southeast of Dry Lake Valley, we reach the foot of a steep escarpment (plate 19A) where there are apparent two, and possibly three, lines of displacement. The middle one passes at the foot of the main cliff, which is between 400 and 500 feet high. It can not be said with certainty that the whole cliff is the result of faulting, altho it is certainly so in part. The formation in the cliff is sandstone of either Tertiary or Cretaceous age. About 5 miles northwest of Bitterwater there is an interesting valley which has been so disturbed that it has no external drainage, while thru its center passes a ridge formed along the Rift. The ridge forms a fine roadbed. Descending toward Bitterwater Valley and P.O., another ridge appears which is as even and regular as a railroad grade. Bitterwater Valley is occupied during the wet season by a marshy lake.

The depression is probably associated in some manner with one of the movements along the Rift. Upon the eastern edge of the valley there is an escarpment about 100 feet high, due to an upward movement upon the northeast side of the Rift.

Southeast of Bitterwater, the Rift leaves the younger formation, and at Lewis Creek both walls are in the Franciscan rocks. For 20 or 25 miles now, the peculiar features of the Rift by which we have followed it are almost absent. The Franciscan series, including old sedimentary rocks, serpentines, and other basic igneous rocks, does not lend itself well to the preservation of such records, but appears to be greatly broken and crushed and marked by enormous landslides in the vicinity of the Rift. The Rift crosses Lewis Creek about 2 miles above its mouth and then passes up over a high ridge lying between Lewis Creek and San Lorenzo Creek. On the north side of Lewis Creek there is an enormous landslide, which has nearly blocked the valley. The slide is undoubtedly hundreds of years old. The ridge on to which the Rift passes after leaving Lewis Creek is crossed by it at such a small angle that it does not reach the southern base until we get to the head of Peach Tree Valley, a distance of 20 miles. The ridge its whole length is shattered and broken, and, as before said, marked by innumerable rockslides. The rather steep slopes appear to move every wet season. The headwaters of the San Lorenzo Creek (Peach Tree Valley) have been robbed by Gaviota Creek, possibly as a result of some movement connected with the Rift. Just above where the stream has been diverted, there is another great landslide which the road crosses to reach Slack Canyon.

At the mouth of Slack Canyon, the Rift leaves the Franciscan series, and coincides again with an ancient fault in which the Miocene sandstones are thrown down upon the southwest against the older formation just referred to. Passing from Slack Canyon over a divide, we come to the headwaters of Indian Creek and Nelson Canyon. As the Rift occupies steep slopes much of this distance, it is distinguished chiefly by landslides and rapid gullying of the surface. In Nelson Canyon the Rift follows an old fault in which the Miocene formation has been thrown down upon the southwest side, and the northeast wall so raised that the granite on which the Franciscan series rests is exposed. Ascending the divide toward the head of Nelson Canyon, a long, nearly straight ridge of Miocene clays divides the drainage and appears to be due to some one of the movements along the Rift.

The Rift can be traced thru the hills at the head of the Cholame Valley by its characteristic features, as well as by bluffs which are undergoing rapid erosion. It crosses the road a mile west of Parkfield and exhibits here a regularly rounded ridge 200 feet wide and 20 feet high at the most elevated point. (Plate 19B.) That the ridge must be hundreds of years old is shown by the great oak trees that are growing upon it. One white oak is fully 8 feet thru. Large springs mark the fissure at this point, and are found along it the whole length of the Cholame Valley. According to a resident, the Rift opened along the ridge in the earthquake of 1901, the opening being distinctly traceable for several miles. Southeasterly from the point just described thru the Cholame Valley, there appears no very prominent ridge or escarpment, altho springs and cienegas, marking a gentle swell in the flat open surface of the valley, indicate the line of the Rift.

The region about Parkfield, in the upper Cholame Valley, has been subjected to more frequent and violent disturbances than almost any other portion of the entire Rift. An auxiliary fissure begins near the main Rift a little west of Parkfield, and extends in a more easterly direction along the east side of Cholame Creek. (See plate 20.) The once flat, open valley has been broken along this line, and a bluff nearly 200 feet high formed facing the Creek. This bluff, now deeply eroded, must have been formed during one of the most disturbances. The lowland between this bluff and Cholame Creek shows the effect of great disturbance over a considerable area. Innumerable hollows interlace and extend in all directions. They resemble nearly obliterated creek beds except that they have no outlets. Parallel with the front of the dissected bluff, but a little back from



A. Looking northwest along the Eift 3 miles southeast of Ohittenden. H. W. P.



B. Ponds along lift near San Benito. H. W. P.



A. The Eift 2 miles soTith of Dry Lake Valley, San Benito Oouty. H.W.F.



B. Ancient scarp <a the line of the Rift a mile weit of Parkfield, Cholame Valley. H.W.F.



A. A branch of the Rift 2 miles southeast of Paikfield, Oholame Valley. H.W.P.



B. Another view of the same. H. W. P.



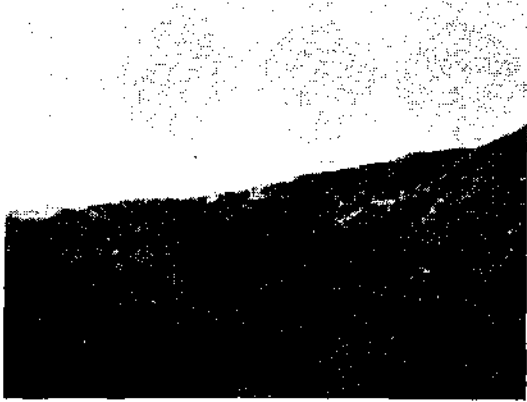

A. Rift, northeast side Oarissa Plain. A. O. L., Jan., 1906.



B. Eift, northeaat aide Oarissa, Plain. A. O. L., Jan., 1906.



C. Eift, northeast side Oarissa Plain. A. O. L., Jan., 1906.



D. Eift, jnst beyond southeast end Oarissa Plain, A. O. L., Jan., 1908.



E. Eift, jnst beyond southeast end Carissa Plain. A. O. L., Jan., 1906.

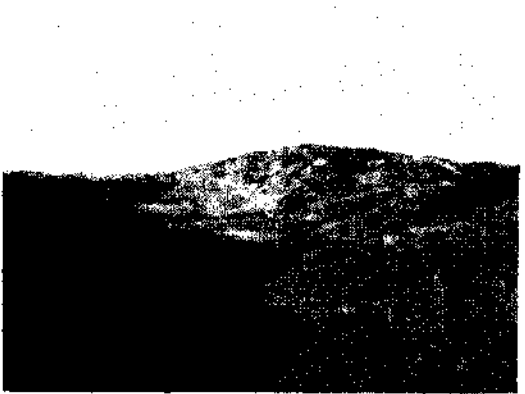

F. Eift, just beyond southeast end Carissa Plain. A. G. L., Jan., 1906.

its upper edge, are two parallel lines of faulting, probably made at a later date than the bluff itself. A small lake occupies a hollow in one. The slopes of one of these V-shaped depressions are quite steep, pointing to a comparatively recent origin.

The people living along the Rift for 150 miles southeastward from the Cholame Valley tell wonderful stories of openings made in the earth by the earthquake of 1857. The first settler in Cholame Valley was erecting his cabin at that time, and it was shaken down. The surface was changed and springs broke out where there had been none before. In 1901 a fissure opened in the road which crosses the branch fault just described. After each successive shake it is reported that the fissure opened anew, so that the road had to be repaired again in order to be passable.

Upon the western side of the Cholame Valley, near its southern end, the main Rift again exhibits an interesting bluff which cuts off the debris fans of the back-lying hills. This bluff faces northeasterly. Where the Rift crosses the creek as it passes out of the Cholame Valley, a low escarpment was formed upon the west side which must for a time have dammed the creek and given rise to a lake. From the outlet of the Cholame Valley the Rift line can be seen as it rises along the low rolling hills, and disappears over their tops. It is marked by a distinctly steeper slope facing northwesterly, showing that an uplift of 30 to 50 feet took place upon the west side. The region traversed thru the Cholame Valley southeast to the Carissa Plain and for some miles beyond, exhibits no older formation than the Miocene Tertiary, the effects of older faulting, if such has occurred here, being masked by recent deposits. Continuing the examination toward the southeast, the writer came upon the Rift at the northern end of the Carissa Plain, 4 miles northeast of Simmler P.O., and in direct line with its course where last seen. Here the width of the broken country is much greater than usual, being nearly a mile. A number of lines of displacement can be distinguished; some nearly obliterated, others comparatively fresh. This is a region of light rainfall and of gentle, grass-covered slopes, presenting just such conditions as would preserve for hundreds of years the effects of moderate displacements.

The Rift zone continues to be traceable along the western base of the Temblor Range, finally passing out on to the gently rolling surface of the eastern edge of Carissa Plain. Broken and irregular slopes, cut-off ridges, blocked ravines, and hollows which are white with alkaline deposits from standing water mark the Rift. Carissa Plain has a length of about 30 miles. About halfway the Rift begins to be marked by a low and nearly obliterated bluff upon its northeastern wall. This is at first little more than a succession of ridges or hills cut off on the side next to the level plains. These detached ridges finally become connected in a regular line of hills with a steep but deeply dissected slope toward the southwest and long gentle slopes toward the northeast. This ridge is clearly a fault block, and now separates the southeastern arm of Carissa Plain from Elkhorn Plain. It probably originated during some one of the earlier movements along the Rift; in fact, it is reasonable to suppose that it is of the same age as other important scarps which mark the Rift thruout its whole course, and which came into existence as a result of some mighty movement opening the earth for several hundred miles.

Except for one slight bend, the ridge which we have been describing follows a straight course toward the southeast for a distance of nearly 20 miles, finally blending in a much larger mountain-like elevation. This has a height of perhaps 500 feet above the sink at its southern base. Its deeply dissected front is in line with the front of the ridge already described and the two appear to have originated together. The steeper face is deeply sculptured into gullies and sharp ridges, while the back slopes off gently toward the southern end of Elkhorn Plain. Plainly visible along the steep front of the line of hills described are the lesser ridges and hollows produced during the last violent earthquake in this region, probably in 1857. (See plate 21A, B, C.)

A gentle divide separates the southern end of the Carissa Plain from a long narrow sink extending along the Rift line toward the southeast. (Plate 21D, E, F.) This sink includes an area 6 miles long and in places its drainage is fully 3 miles wide. Several depressed alkali flats, covered with water during the wet season, receive the scanty run-off of this dry region. These depressions are several hundred feet wide and are bordered upon opposite sides by quite sharp bluffs, in some places 100 feet high. The phenomena suggest the sinking of long narrow blocks between two walls. This reach of 6 miles between the ranches of Job and Emerson is one of the most interesting areas examined. The larger scarps belong to some ancient disturbance, while the last one, probably dating from 1857, is marked by features comparatively insignificant.

As we ascend the long grade from the sinks just described, to Emerson's place, near Pattiway P.O., the Rift features become smaller and less regular, altho easily followed. (See plate 23A.) At Emerson's the Rift passes thru a sag in the hills and across the head of Bitter Creek. It then rises and crosses a flat-topped hill between this creek and the west fork of Santiago Canyon; and descending to the east fork keeps along the steep mountain slope upon the south until it finally crosses the divide between San Emedio Mountain and Sawmill Mountain. Thru this section the Rift gradually bends toward the east, and in Cuddy Canyon, farther east, it has an east and west direction for a few miles.

The Rift itself is scarcely distinguishable in Bitter Creek and Santiago Canyons, owing to steep slopes and rapid erosion, as well as numerous landslides. Santiago is one of the deepest and narrowest canyons in this portion of the mountains. Its whole southern slope, that traversed by the Rift, has been more or less affected by slides producing many little basins along the edge of the flat-topped divide between the drainage into the San Joaquin Valley and Cuyama River. Huge masses of earth and rock are still moving, as shown by fresh cracks and leaning trees. In one place the edge of the divide has split away in such a manner as to produce long narrow ridges with depressions behind them, closely imitating the real Rift features. Santiago Canyon marks a great fault of earlier times. Soft Tertiary formations are faulted down thousands of feet upon the south side of the canyon, while upon the north appear the steep granitic slopes of the western spur of San Emedio Mountain.

The Rift appears upon the north side of the pass which leads from Santiago Canyon to San Emedio Canyon. Two lines of disturbance are here plainly visible. Going down the west branch of San Emedio Canyon, the Rift zone is plainly traceable, but nowhere does it form important features. Passing to the east fork of the canyon, we continue on the line of the Rift to the divide leading over to Cuddy Valley. (See plate 22A.) Beginning upon the divide, a broad rounded ridge, fully 50 feet high upon its southern side, extends down the slope in a direction a little south of east. Cutting thru the center of this ridge longitudinally is a deep V-shaped depression, as tho a movement later than that which formed the ridge had opened a fissure thru its center. On the sides of the ridge, as well as the slopes of the fissure in it, large pine trees are growing in an undisturbed condition. Continuing down the ridge, we find that in the course of a mile it gives place to an escarpment facing northerly. A valley 4 miles long and 0.5 mile wide lies below the escarpment and contains meadows and a small lake without any outlet. Springs mark the Rift line. The escarpment has been much eroded, but toward its eastern end it has a height of nearly 300 feet and is covered with a growth of pine trees among which are stumps of large dead trees in an undisturbed condition. The valley and the bluff are doubtless the product of the earliest movement in the epoch of which we are treating. The last movement left a comparatively small ridge traceable here and there along the base of the greater.

Continuing on the line of the Rift, we enter and pass for 10 miles down Cuddy Canyon.



A. Looking south-southeast along the Kift toward Onddy Valley from lead of San Emedio Canyon. H. W. F.



B. Old fault-scarp in Eift. East end of Caddy Valley. H.W.F.



A. Looking northwest along the Rift from Emerson's place, near Pattitway. H. W. F.



B. Looking east along the Rift from Gorman Station. The low scarp was probably made in 1857! E. W. F.

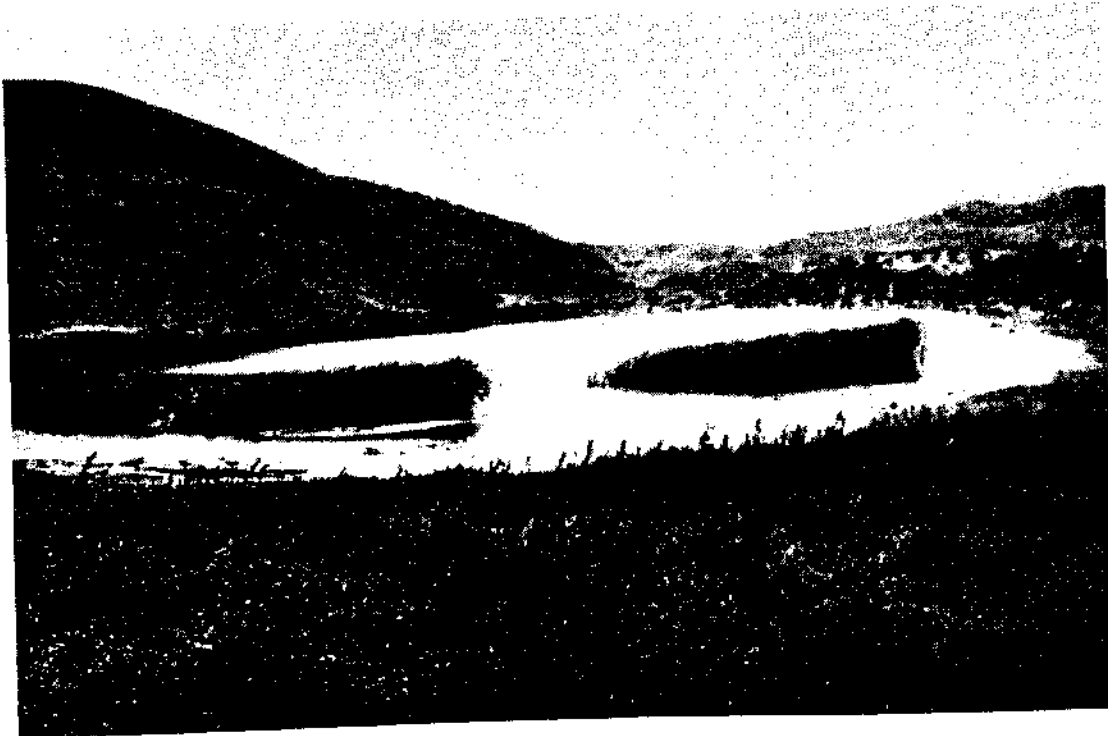

A. Pond and soarp in Rift east of Gorman Station, H. W. P.



B. Lower Lake Elisabeth. In the Rift. H. W. F.



A. Looking southeast along the Eift between Lake Elizabeth and Palmdale. H.W.P.



B. Looking east along the Eift »carp west of Palmdale. H.W.F.

(See plate 22B.) The fissure follows its northern side for several miles and then, bending a little toward the south, crosses the canyon and takes a course for Tejon Pass. The granitic mountains upon the north of the canyon rise with exceedingly steep slopes, the rocks of which have been thoroly shattered. Immense quantities of rock débris have been brought down the gulches, building up in the main canyon a succession of large and steep débris fans. So much débris has been carried down the canyon that it has been blocked at the point where it turns toward old Fort Tejon, and has thus given rise to Castac Lake. The Rift crosses the divide at the gap known as Tejon Pass. Here there are features due to two movements. Descending a few hundred feet, we find ourselves in a long valley, extending about 10 miles in a direction a little south of east. Springs, marshes, and two ponds mark the line of the Rift from Gorman Station easterly. (Plates 23B and 24A.)

At Gorman Station, several miles below Gorman, there is a wonderfully regular ridge forming a marsh. In this vicinity the earthquake of 1857 is reported to have done much damage, shaking down an adobe house and breaking up the road. The little lake upon the divide halfway between Gorman Station and Neenach P.O. is due to débris brought down from the hills upon the south thru which the Rift zone passes. The Rift follows a very regular and straight course, a little south of east, along the mountain slopes south of Antelope Valley. Thru the most of the distance, as far as Palmdale, it occupies a series of valleys shut off by considerable elevations from the open slopes of Antelope Valley. After traversing the northern slopes of Libre and Sawmill Mountains, the Rift crosses the head of Oak Grove Canyon, then another small canyon with branches eastward and westward along the break, and eastward of this a long canyon opening out to the fertile valleys about Lake Elizabeth.

Lake Elizabeth and Lower Lake (plate 24B) are both due to the blocking of the drainage of two valleys extending along the Rift. These valleys lie on the slope of the range toward the desert (Antelope Valley), but their outlet is southward by a narrow canyon thru the heart of the mountains lying between the desert and Santa Clara River. A low escarpment along the southern side of the valley in which Lake Elizabeth lies, and eastward, is replaced by a lofty rounded ridge which appears to be due to some one of the movements along the old fault. For several miles east of the lake (plate 25A) the distinctive and characteristic features of the Rift are not as easily made out, altho the ridge just mentioned is full of springs and exhibits a widespread landslide topography. Toward the eastern end of this ridge small hollows and a low, indistinct escarpment again appear. The ridge separates Leones Valley, a fertile and well-watered district 5 or 6 miles long, from the open Mojave desert on the north.

From Leones Valley to and beyond the point where the Rift zone crosses the Southern Pacific Railway, a constant succession of cienegas is found on the upper side; that is, on the side toward the mountains. Movements have evidently been so often repeated and so intense along the Rift as to grind up the rocks and produce an impervious clayey stratum, bringing to the surface the water percolating downward thru the gravels of the waste slopes. A mile west of Alpine Station on the Southern Pacific Railway, there begins another escarpment with its abrupt face toward the south. This extends to and across the railroad. South of the escarpment the surface has sunk so as to form a basin. (Plates 25B and 26A.) This has been artificially enlarged and used as a reservoir for irrigation about Palmdale. The main escarpment is 40 to 50 feet high in places, and where the railroad crosses it there appear to be two, an older and a younger one. From the summit of the ridge marking the Rift west of Alpine, an extensive view eastward is obtained. The long desert waste plain leading up to the foot of the mountains on the south (San Gabriel Range) exhibits a strikingly interesting feature. It is not continuous across the line of the Rift, but shows a break with the uplift upon the lower side. The amount of displacement appears to be between 200 and 300 feet.



An extended study would be necessary to determine in detail the geology of the Rift from Gorman Station eastward. Near Gorman a dike of basaltic or andesitic lava extends parallel with it for some distance. Granitic rocks often form one side, while soft Tertiary beds of a light or reddish color frequently appear in the raised ridges. Between Palm-dale and Big Rock Creek, low discontinuous ridges, springs, and cienegas point out the line of the Rift, altho there are stretches of several miles at a time where either the original displacement was not great or erosion has removed its effects. Four miles west of Big Rock Creek there is one fine escarpment 0.333 mile long and 40 feet high, facing the mountains on the south. (Plate 27A.) In this section there are indications of at least two movements. (See plate 26B.) The Rift passes just below Big Rock P.O. east of Big Rock; a trail on the northern slope of the mountains and a wagon road on the southern side of the divide follow the Rift continuously to a point near the mouth of Cajon Canyon. On the north side of the mountains (San Gabriel Range) there is no important depression on the Rift between Big Rock Creek and Swartout Valley; nevertheless the comparatively recent movements have been of sufficient magnitude to produce ridges and hollows giving a continuous and easy route for the trail along the slope of the mountains.

Before reaching the divide leading over to Swartout Valley, we encounter some striking features. Near the head of Mescal Canyon a ridge has been split away from the mountain, diverting the little streams from above and making two drainages where one would normally appear. In places this ridge (plate 27B) is as sharp and as perfect as tho formed but yesterday; but the great pine trees, growing upon its top and sides (the altitude here being nearly 7,000 feet), tell us that it must be hundreds of years old. At the head of the canyon the trail leads thru a sharp V-shaped cut where the bare sliding surfaces make it appear as if movement had recently taken place in the Rift. (See plate 28A.)

Passing over a sag in the mountains to Swartout Valley, the Rift is less prominent as a topographic feature, but a line of springs marks its course. Lone Pine Canyon is remarkable for its length and straightness. The Rift passes down its whole length but it is not very prominent. Springs appear at several points, also small cienegas with a slight escarpment below them. At the mouth of Lone Pine Canyon and a little above its junction with the Cajon Canyon (plate 28B) are more interesting features. Two lines of displacement appear here, and between them a long, narrow sunken block with a small lake in its lowest portion. (See plate 29A.)

The line of disturbance now crosses Cajon Canyon, giving rise to broken and sliding cliffs; and then, passing over a spur of the San Bernardino Range, comes out at its foot before reaching Cable Canyon. From this point the Rift continues on southeasterly at or near the junction of the gravel slopes of the San Bernardino Valley and the steep mountain slopes of crystalline rocks. The uniformly straight course which the Rift exhibits in this portion of its length takes it diagonally across the mountains from the northern and desert side of the San Gabriel Range to the southern side of the San Bernardino Range.

The torrential streams emerging from the San Bernardino Range upon the gravel slopes of the broad valley at its base have cut wide flood plains in the ancient gravels which accumulated along the foot of the mountains. The remaining portions of this old slope lying between the stream plains are called mesas. Back of Devore Heights there appears a rounded ridge formed out of the mesa gravels. As we continue toward Cable? Creek, springs and cienegas are found to be numerous just above it. East of Cable? Creek the ridge becomes an escarpment facing the valley, and in places shows a height of about 75 feet. Viewed in profile, this escarpment breaks the uniform slope of the mesa gravels, almost reversing their slope on the upper side. On the west side of Devil Canyon there is a double escarpment in the gravels, both apparently being due to movements along the Rift. (See plate 29B.) Back of the Museupiabe Indian reservation and north of the



A. Sink between 2 soarps of the Rift a mile south of Palmdale, H. W. P.



B. Pond in the Eift 2 milei west of Big Kock Creek, Moja« Desert. H. W. F.

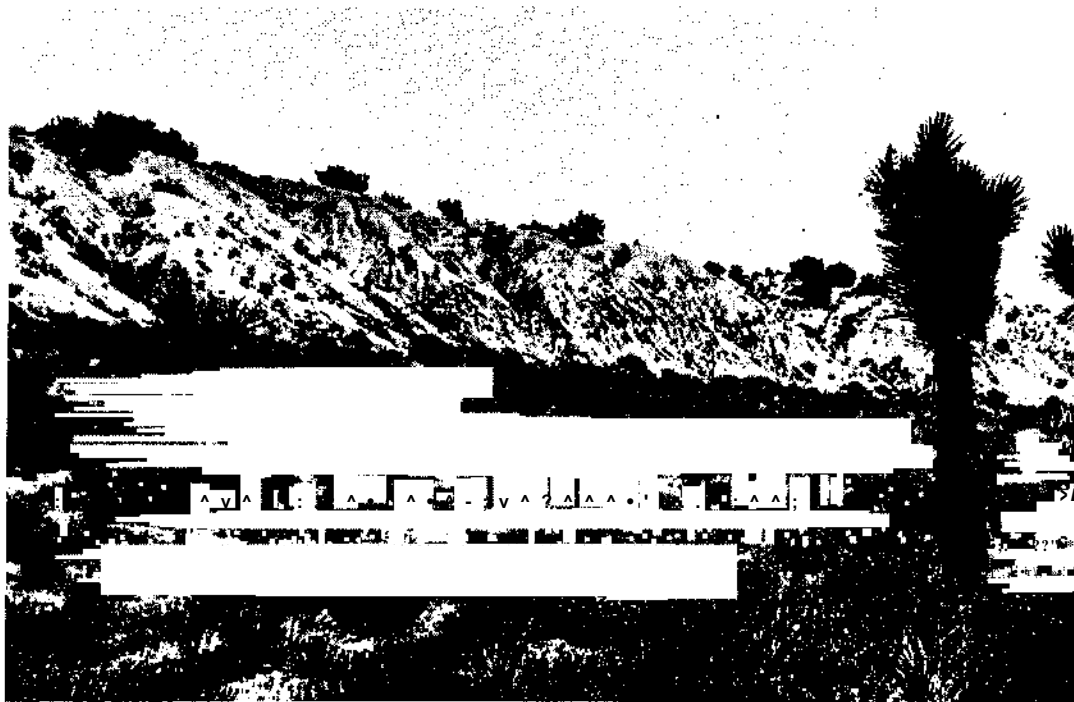

A. Fan-t-scarp in the Eift. Mojave Desert west of Big Eock Oreet, H.W.F.



B. Ridge in the Eift near the head of gwartoat Valley. H.W.F.



A. The lift across the mountain crest west of Swartout Valley. North slope of San Gabriel Range. H. W. F.



B. Looking southeast from lower end of Lone Pine Canyon across lower end of Cajon Canyon. Lake and meadow due to ridge in Eift. H. W. P.



A. Looking west along the Eift from Cajon Pass, showing double scarp. H. W. F.



B. Double fault-scarp in Rift north of Hightod, at base of Ba. Ben-idiuo Ea. g. H. W. P.

Asylum, there is a much dissected fault cliff 200 to 300 feet in height. Plainly traceable in the front of this cliff is a small break, possibly made in 1857. No definite information could be gained as to whether the earth opened here at that time, but reports say the earthquake was very severe, throwing animals from their feet, etc.

East of City Creek begins a huge rounded ridge formed in the mesa gravels, and this can be traced nearly to Plunge Creek. This ridge is 150 feet wide and steeper upon its upper side, where the greatest displacement shown is about 40 feet. The structure and shape of the gravel ridge make it appear likely that faulting and folding were both concerned in its making. Above this ridge and at the highest point where it crosses the mesa, water is obtained in abundance for irrigation at a depth of 18 to 20 feet, while in the mesa below the ridge no water is found at a depth of 200 feet.

The Santa Ana River has cut out a wide stretch of the mesa gravels, and has exposed upon its eastern bank a good section of these gravels. The gravels at their upper edge do not lap over the crystalline rocks but appear faulted down against them. A 0.25 mile below the fault is the mouth of Morton Canyon, the stream issuing thru a long, narrow canyon eroded in the mesa gravels. Morton Canyon emerges from the steep mountains about 2 miles to the southeast and has taken this peculiar course thru the gravels to the Santa Ana River, instead of flowing directly down across them, as do all the other streams. The explanation of the turning to the northwest of this canyon at the point where it meets the gravels is found in the peculiar appearance of the gravel slope when viewed in profile. This, instead of rising with normal slope, becomes steeper toward the upper edge, and then descends abruptly to Morton Canyon. The movement on the Rift has broken and lifted up the gravels to such an extent that the waters of Morton Canyon were diverted and turned down to the Santa Ana River along the upper side of the ridge. Since this displacement took place, they have had time to cut the canyon in which they are now flowing. Southeast of the point where the Rift crosses Mill Creek, the peculiar topographic features which have characterized it for so many miles become very indistinct. It was at first thought that the Rift terminated in this vicinity but closer examination made it clear that such is not the case.

The southern portion of the San Bernardino Range lying between Mill Creek and the Conchilla Desert appears to have undergone great disturbance at a recent date. As a consequence, erosion has been rapid and extensive, and surface features which farther north made the Rift easy to follow have in this region been almost completely obliterated. Potato Canyon extends along the line of the Rift to the southeast of Mill Creek. Its features indicate that the history of the fault is a complex one. The canyon originated thru erosion upon the fault contact between the crystalline rocks of the San Bernardino Range and the older Pleistocene deposits along its base. Following this period of erosion was one in which gravels were again deposited and this was succeeded by the present period in which erosion is active. Potato Canyon is the last of the longitudinal depressions of any size marking the line of the Rift. Between its head and the desert to the southeast the main drainage features pay little attention to the structural conditions, because of the steep grades of the stream channels and consequent rapid erosion. Nevertheless small lateral canyons have been formed along the fault contact of the gravels with the crystalline rocks of the higher portion of the San Bernardino Range, so that from the proper viewpoint the fault line can generally be traced in the topography. The drainage of Potato Canyon is clearly influenced by the fault, for instead of there being one stream course in it, there are two — one upon each side.

A mile southeast of Oak Glen, which is at the head of Potato Canyon, there are large springs which issue upon the line of the fault. Near this point a depression appears upon a gravel ridge, where it meets the crystalline rocks. The depression is in line with the course of the fault, and may with reason be attributed to dislocations similar to those so

clear farther north. Two miles southeast of Oak Glen is Pine Bench, a mesa-like remnant of gravel having an elevation of about 5,000 feet. At the northern edge of this mesa, and upon the line of the fault, there is a regular escarpment facing the higher mountains. It is most reasonable to interpret this as indication of the same displacement referred to previously.

To the east of the San Gorgonio River, the topography as shown upon the San Gorgonio quadrangle gives little indication of the presence of an important fault-line. However, an examination of Potrero Creek shows small transverse canyons and one broad, grassy flat with springs upon the line of the fault. In Stubby Canyon and other small canyons north of Cabazon Station, the fault is finely shown. Here, as at the point where the Santa Ana River issues from the mountains, the older Pleistocene gravels have been faulted down against the crystalline rocks. Rapid erosion of both the Pleistocene deposits and the crystalline rocks has given rise to steep and precipitous slopes in this section, and upon these the fault is clearly shown. The schists and gneisses thru a width of hundreds of feet adjoining the fault have been so crushed by pressure and movement that they quickly crumble upon exposure. Dark clay marks the plane of movement which inclines to the north at an angle of about 80 degrees. Later than the period of main faulting has come an elevation of the range as a whole, giving rise to rapid erosion upon both sides of the line of fracture. Remnants of gravel mesas and mature topographic forms appear in places. A notable example of an area of old topographic features now being destroyed by the modern canyons is shown to the west of Stubby Canyon and 1,000 feet above it.

There are traces here and there of recent displacements along the Rift. These are of the nature of little sags without outlets and low ridges or escarpments not easily explainable as a product of ordinary erosion. These may have arisen as the product of landslides, but the landslides themselves are doubtless related to fault movements. The great debris fans built up along the north side of San Gorgonio Pass indicate rapid removal of a vast amount of rock material from the adjoining slopes of the San Bernardino Range consequent upon recent uplift.

Before investigating this region it was thought that the Rift, if it continued on southeasterly, would be found crossing the San Gorgonio Pass in the neighborhood of Cabazon and skirting the eastern base of the San Jacinto Range; but this proved not to be the case. Instead, it was found to turn more and more easterly and finally to extend parallel with the pass without reaching it. The course of the Rift, then, instead of being in the direction of the Salton Sink, is toward the Conchilla Desert north of Palm Spring Station.

Looking east from a point near the mouth of Stubby Canyon, the gravel mesa thru which the Whitewater River issues from the mountains, appears to be faulted upward, giving rise to a well-defined escarpment facing north toward the crystalline rocks. This northward facing escarpment accords in relative position with the traces of escarpments farther north near Oak Glen, and shows that the latest displacement has been the reverse of the earlier. The last seen of the Rift is in the sides of the Whitewater Canyon, where the gravels are faulted down against the crystallines. East of the Whitewater one enters upon the Conchilla Desert over which has been spread the wash of Mission Creek. For a distance of 6 or 8 miles, and perhaps much more, the bedrock is completely buried by the recent accumulations.

The San Bernardino Range rapidly decreases in height to the southeast of Mission Creek, but appears to be continuous with the desert range lying north of the Salton Basin. The latter range of crystalline rocks appears to be separated from the lowlands of the basin by a more or less continuous line of barren yellow hills formed of soft late Tertiary rocks. Judging from a cursory examination, these yellow hills are separated from the higher mountains behind by a structural break indicated by a series of longitudinal valleys. A prolongation in a northwesterly direction of the supposed fault line indicated by these

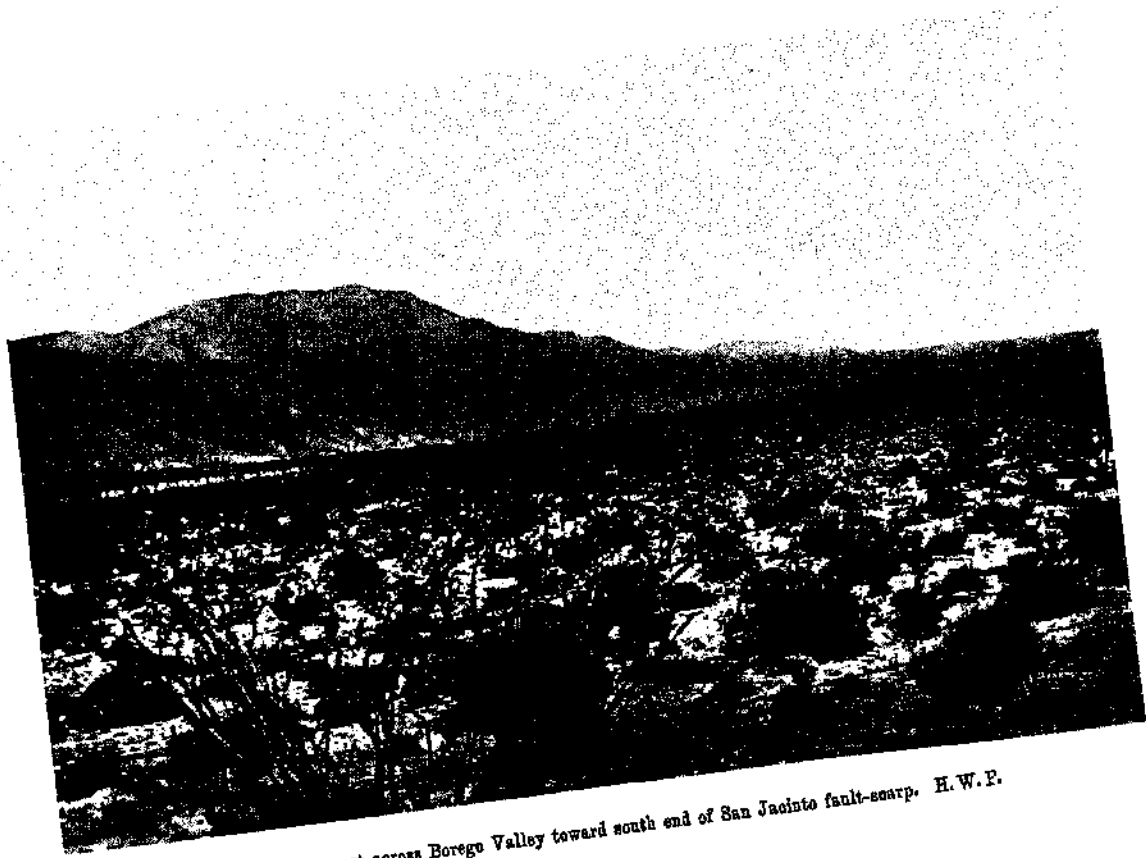

A. Looking east across Borego Valley toward south end of San Jacinto fault-scarp. H.W.F.

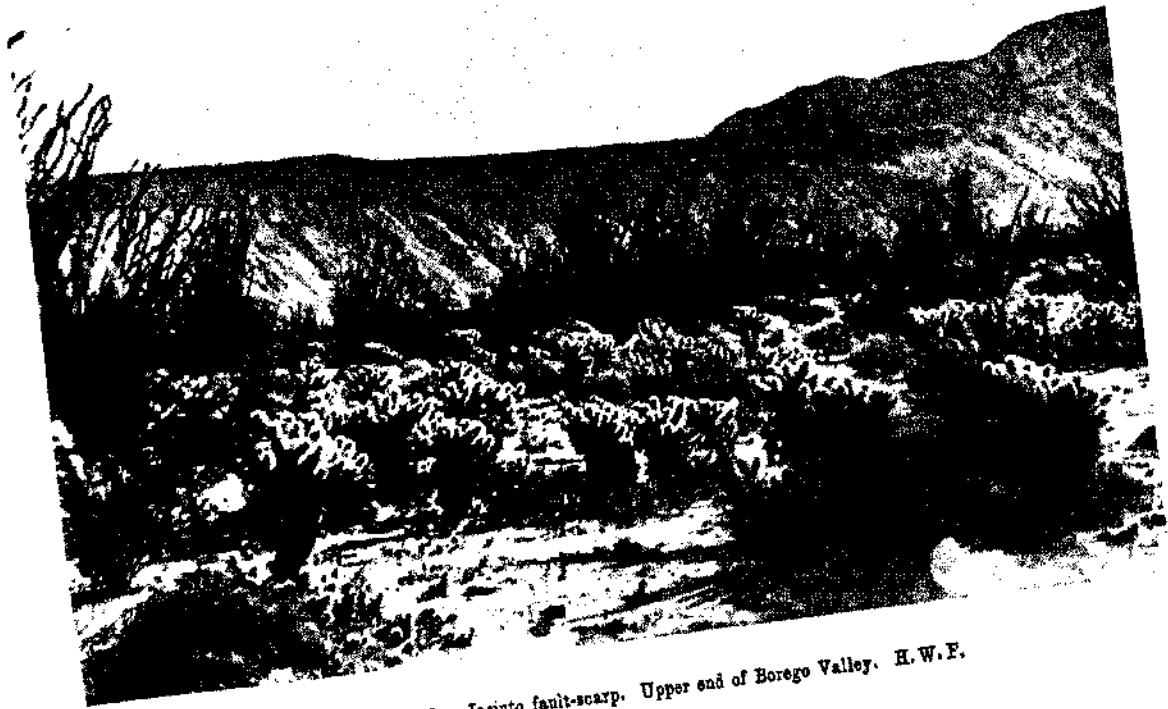

B. A nearer view of the San Jacinto fault-scarp. Upper end of Borego Valley. H.W.F.



valleys would carry it into the San Bernardino Range at the point where Mission Creek emerges upon the wash plain. Continuing still farther northwest, we follow a marked topographic break which leads across the southern slope of San Gorgonio Peak to the head of Mill Creek. It is very probable that the great fault followed so far joins the above fault-line at some point easterly from Palm Spring Station, altho the many miles of gravel-covered desert makes a positive statement impossible with present knowledge.

An examination of the northerly and easterly base of San Jacinto shows conditions opposite to those characterizing the southern slope of the San Bernardino Range. Erosion is generally slow upon the slopes of San Jacinto, while the rapid erosion from the opposite side of San Gorgonio Pass has crowded the stream channels close to the base of the former range. In fact, the base of the San Jacinto Range appears to be deeply buried by the stream deposits. The desert face of San Jacinto has long been free from disturbances. Long, jagged ridges project out into the desert, while the intervening canyons, instead of furnishing material for extensive débris fans, are floored by accumulations characteristic of the desert as a whole.

Toward the southern end of that spur of the San Jacinto Mountains which projects into the Colorado Desert and is known as the Santa Rosa Mountains, the débris fans are larger and remains of gravel deposits appear high up on the sides of the mountains. The only suggestion that a fault traverses the Salton Basin in the direction of the mouth of the Colorado is the presence of mud volcanoes and several small pumiceous eruptions near the center of the basin. These are, however, so far removed from any known fractures in the crust that their evidence is of little value. Besides, it is entirely possible that the mud volcanoes may be due to chemical action in the deeply buried sediments of the Colorado delta.

It may be reasonably assumed, then, from our best knowledge, that the southern end of the great Rift is to be traced for an unknown distance along the base of the mountains bordering the Salton Basin upon the northeast, in all probability gradually dying out.

#### SAN JACINTO FAULT.

The San Jacinto fault (plate 30), with which there has been associated at least one severe earthquake since the region has been known, has a length of at least 75 miles. The course of the fault is northwest and southeast, and it is marked by canyons or steep mountain scarps nearly its whole length. The fault first appears upon the south in the form of a regular mountain wall inclosing the north end of Borego Valley. The latter is a western arm of the Colorado Desert lying between the Santa Rosa Mountains and the main watershed of the Peninsular Range. At the northern end of Borego Valley beds of late Tertiary age appear faulted down upon the southwest side of the mountain wall referred to. The peculiar topographic features of this fault-block ridge, and the presence of gravels along portions of its summit, make it appear of recent origin. Northwest of Borego Valley the canyons entering Coyote Creek have brought down immense quantities of rock débris, a fact which indicates recent disturbance along their headwaters. Terwilliger Valley includes a broad expanse of country of low relief upon the summit of the range between San Jacinto and Borego Valley. A portion of the valley is scarcely drained at present, having apparently undergone some subsidence next to the fault-line which forms the southern face of Mount Thomas.

In a northwesterly direction, the fault can be traced in continuous mountain scarp or canyon until within about 8 miles of the town of San Jacinto. A broad valley intervenes until we get north of the town, when a mountain wall commences again, and extends for many miles in the direction of Colton. Reports state that the San Jacinto earthquake of 1899 was most severe along the line of the fault thus traced. Great masses of rock are

reported to have been thrown down in Palm Canyon, which issues from San Ysidro Mountain. Ten miles southeast of San Jacinto, on the line of the fault, it is said that a considerable area of land sank with formation of open fissures. Upon the Coahuila Indian Reservation, adobe buildings were thrown down and much damage was done in the town of San Jacinto.

The regular mountain wall facing southwest and extending northwest from San Jacinto appears to be older than that toward the southern end of the fault. Mineral springs occur near or on this line, and the marshy area at the point where the San Jacinto River ceases following this fault-scarp and turns toward the southwest suggests very strongly a subsidence.

#### REVIEW OF SALIENT FEATURES.

It will be of advantage briefly to review the salient features of the San Andreas Rift, in the light of the facts presented in the foregoing detailed description of its extent and character, and of other facts to which attention will be directed.

The San Andreas Rift has been traced with three interruptions from a point in Humboldt County, between Point Delgada and Punta Gorda, to the north end of the Colorado Desert, a distance of over 600 miles. These three interruptions are: The stretch between Shelter Cove and the mouth of Alder Creek, where for a distance of about 72 statute miles it traverses the bottom of the Pacific Ocean; the stretch from the vicinity of Fort Ross to Bodega Head, where for 13 miles it is similarly on the ocean bottom; and the stretch from Bolinas Lagoon to Mussel Rock, where it lies beneath the Gulf of the Farallones for about 19 miles. Of these interruptions only the first involves any doubt as to the continuity of the feature, and this doubt is in large measure removed by the evidence cited hereafter as to the position of the trace of the fault of April 18, 1906.

Thruout its extent the Rift presents a variable relation to the major geomorphic features of the region traversed by it. In Humboldt County it lies within the mountainous tract inland from the coast but to the seaward side of the higher land. From Shelter Cove to Alder Creek it lies to the west of a steep, terraced, coastal slope. From Alder Creek to Fort Ross, it finds its expression in a series of rectilinear, sharply incised valleys, the alinement of which converges upon the coast line to the south at a very acute angle. But near Fort Ross the Rift, without deviation of its general trend, crosses the divide to the coastal side of the ridge which separates these valleys from the ocean, and traverses the terraced coastal slope. Beyond Fort Ross it again lies to the west of a steep coastal slope. From Bodega Head to Bolinas Lagoon the Rift is a remarkably pronounced depression, lying between the main coastal slope and the rather high and precipitous easterly side of the Point Reyes Peninsula. About 0.6 of this depression is below sea-level, forming Tomales and Bodega Bays. This defile is one of the most remarkable and interesting phases of the Rift. It has been a line of repeated faulting in past geological time, and evidently separates a well-marked and probably relatively mobile crustal block from the main continental land mass.

South of Mussel Rock the Rift traverses for a few miles a rolling upland, marked by ponds and old scarps, but with no very marked contrast in relief, and then passes into the very marked and rectilinear San Andreas Valley, along the base of the northeast flank of the Santa Cruz Range. From here to the gap at Wright Station it lies along the base of the range at a distance nowhere greater than 2 miles from the crest. Passing thru the gap at Wright, it crosses from the northeast flank of the range to the southwest flank. Similarly passing thru the gap between the Santa Cruz and Gavilan Ranges at Chittenden, it is again found on the northeast flank of the latter. In effecting this last-mentioned change of position relatively to the mountain crests, a distinct deviation in the trend of the Rift is observable (see map No. 5) as if the path of the Rift accommodated itself to

the mass of the mountain blocks. Farther south, near Bitterwater, the Rift leaves the northeast flank of the Gavilan, and lies along the southwest base of a straight ridge of the Mount Hamilton Range. Still farther south in Cholame Valley it follows the northeast base of the ridge which separates Cholame Valley from San Juan Valley. In the Carissa Plain it hugs the southwest flank of the Temblor Range. But the most noticeable reversal of the relative position of the Rift to the adjacent mountain slopes is beyond Tejon Pass. From Tejon Pass to near Cajon Pass, the Rift lies along the steep northerly flank of the San Rafael and San Gabriel Ranges, on the southern edge of Mojave Desert; but at Cajon Pass it passes thru between the San Gabriel and San Bernardino Ranges, and thence easterly lies on the south side of the latter range. Thus from the San Francisco Peninsula to its southern end, so far as the extent of the Rift is at present known, there is a fairly regular and rather remarkable alternation of the relative positions of the Rift and the mountains adjacent to it.

The Rift as a whole, when plotted upon a general map of the state on a scale of about  $\frac{1}{100,000}$  appears as a sensibly even line with marked curvature, convex toward the Pacific. This curvature is for the most part due to change in the course of the Rift between the southern end of Carissa Plain and Tejon Pass. In this segment of its course its trend changes from about S.  $40^{\circ}$  E., along the edge of Carissa Plain to S.  $65^{\circ}$  to  $70^{\circ}$  E., along the southern edge of the Mojave Desert, the change being gradual and distributed over an arc about 40 miles in length. The general curvature is also accentuated by the change in course between Point Arena and Shelter Cove, on the assumption of continuity between these points. If, however, we take the segment of the Rift between Point Arena and the south end of Carissa Plain, the curvature is very much less marked; and its path on the small scale map referred to approximates a straight line. The curvature is distinct, however, and, as in the general case, is convex to the Pacific. The chord of the arc found by stretching a line from the south end of Carissa Plain to the mouth of Alder Creek has a bearing of about N.  $40^{\circ}$  W. and a length of about 360 miles. The point on the arc most distant from this chord is on a normal to the latter thru San Jose, the distance being about 15 miles.

When the Rift is plotted on larger scale maps (see maps Nos. 2, 4, 5, 21, and 23), it becomes apparent that the course of the Rift is not a smooth uniform curve, but is characterized by several minor curvatures in opposing directions. In locating these curves, advantage is taken of the fault-trace, as far as it extends, as a sharp line within the Rift indicating its mean trend at any point on its course. These curvatures are most interesting features on a line of diastrophic movement, where that movement may be, as it was on April 18, 1906, essentially horizontal on a nearly vertical plane or zone.

The most northerly curvature susceptible of measurement is that shown by the segment of the Rift between the mouth of Alder Creek and Fort Ross. The line connecting the two ends of this segment, at the points where it intersects the shore line, is a little more than 43 miles in length, and has a bearing N.  $37^{\circ}$  W. The Rift, as located for this purpose by the fault-trace, lies wholly on the southwest side of this chord. The bearing of the fault-trace at the mouth of Alder Creek, where it converges upon the chord, is N.  $30^{\circ}$  W., and at Fort Ross its bearing is N.  $40^{\circ}$  W. The fault-trace is at its maximum distance from the chord about the middle of this segment, the distance being about 0.75 mile, and here the bearing of the Rift is sensibly the same as that of the chord, N.  $37^{\circ}$  W. Between Fort Ross and Bodega Head, where the Rift passes under the Pacific, there is probably a slight reversal of this curvature; since, if the course of the fault-trace at Fort Ross were continued, even as a straight line, it would pass to the eastward of the point where it actually intersects the neck of the headland. This slight concavity to the southwest probably extends as far as the mouth of Tomales Bay. From Bodega Head south thru Tomales Bay to Bolinas Bay, the course of the Rift as a large geomorphic feature is

practically straight, with a bearing of N.  $37^{\circ}$  W., for 35 miles; but there are slight curvatures in the fault-trace within the Rift. For example, the fault-trace, in its path thru Tomales Bay, must be slightly convex to the southwest to clear the little headlands on the northeast side of the bay, as it apparently does. There is a similar slight convexity to the southwest between the head of Tomales Bay and Bolinas Bay. The complementary concavity between these two convexities is near the head of Tomales Bay.

Between Mussel Rock and San Andreas dam, the fault-trace has a slight concavity to the southwest. The projection of its course seaward from Mussel Rock would not meet the southward projection of the fault-trace from Bolinas. There can be little question as to the continuity of the fault-trace across the Gulf of the Farallones; and its path on the bottom of the Gulf must, therefore, take the form of a very flat sigmoid curve, with a slight concavity to the southwest in the Bolinas moiety of the submarine segment and a corresponding convexity at the Mussel Rock end. Between San Andreas dam and Chittenden, the fault-trace indicates a pronounced curvature in the general trend of the Rift. The chord between these two points is about 55 miles in length and bears N.  $44^{\circ}$  W. The fault-trace lies wholly to the southwest of this line, with convexity toward the Pacific. The point on the curve most distant from the chord is about its middle part, the distance being about 2.25 miles. On this segment of the Rift there is locally a rather abrupt reversal of the curve, south of Black Mountain, which is best seen on map No. 22.

Between Chittenden and a point near Priest Valley there is another pronounced curvature in the general course of the Rift, where it passes over to the northeast flank of the Gavilan Range. Here the curvature is concave toward the southwest. The chord is 60 miles long, and bears, as before, N.  $44^{\circ}$  W., and the Rift lies wholly on the northeast side. The point on it most distant from the chord is near the middle of the segment, and the distance is 2.4 miles. From Priest Valley to the south end of Carissa Plain, the Rift is nearly straight, but with minor curvatures which can not be more particularly defined, owing to the absence of good maps. The general bearing for this segment is about N.  $40^{\circ}$  W.

The marked curvature between the south end of Carissa Plain and Tejon Pass has already been noted. From the latter place to the north end of the Colorado Desert, beyond which the Rift has not been traced, there are numerous curvatures in the course of the Rift; but since the Rift for this segment is indicated on maps Nos. 6 to 15 on a scale of 1 or 2 miles to the inch, it will be unnecessary to do more than refer to these maps for their characterization. The general course of the Rift in this region is a flat curve concave to the south-southwest.

It thus appears that the Rift, as a whole, has a curved course convex to the Pacific; and that this general curvature is characterized by a succession of slightly curved, rather than straight, segments. The amount of the curvature, as it appears upon the maps, is determined to some slight extent by the character of the projection. But the general conclusion above reached without quantitative expression is independent of the projection adopted for the maps.

A most interesting general feature of the Rift is in relation to the granitic rocks of the Coast Ranges. The granites of the southern Sierra Nevada pass into the Coast Ranges in the vicinity of Tejon Pass, and extend thence in a series of more or less elongated but discrete areas thru the Santa Lucia, Gavilan, and Santa Cruz Ranges, and beyond the Golden Gate to Point Reyes Peninsula and Bodega Head. From the southern end of Carissa Plain to Bodega Head, this granite lies wholly to the southwest of the Rift. At one point in the Rift, however, in Nelson Canyon, Fairbanks has found the granite exposed on the northeast side of an old fault having a downthrow on the southwest. Southward it passes into a region where granitic rocks prevail on both sides of the Rift. The Rift in the Coast Ranges thus appears to serve as a line of demarkation between two

somewhat contrasted geological provinces; one in which granitic rocks are extensive and important features, and the other in which granitic terranes are wanting. This fact further suggests that the two provinces will be found to be contrasted in other respects when the details of the Coast Range geology are better known. The general fact is indicative of relatively greater uplift on the southwest side of the Rift, and consequently deeper denudation, whereby the rocks of the granitic complex have been stripped of their covering and so exposed to view. In that portion of the Coast Ranges south of the Bay of Monterey, the Santa Lucia Range along the coast is much higher than any of the other ranges which intervene between it and the great valley.

In a discussion of the Rift as a geomorphic feature, it becomes a matter of interest to determine the relative importance of diastrophism and erosion in its evolution. There can be no doubt that where the Rift is coincident with pronounced longitudinal valleys, the latter, altho controlled as to orientation by the faulting along the Rift, owe their features in a large measure to erosion. This is true, for example, of the valleys of the Garcia and Gualala Rivers and the San Andreas Valley. It is not so clear, however, as regards the depression between Point Reyes Peninsula and the mainland. It has been pointed out that in past geological time there has been a recurrence of faults with large vertical displacement on this portion of the Rift, dating back to pre-Miocene time and possibly to the Cretaceous; and it may be that here the depression is essentially diastrophic in origin and only modified to a minor degree by erosion; similarly with some of the valleys along the Rift, and extending from it in the Southern Coast Ranges. The Cholame Valley and the valley of Carissa Plain may be essentially diastrophic in origin, modified by erosional degradation on their sides and by aggradation of their bottoms. The depressions which constitute the Rift along the southern margin of Mojave Desert appear to be practically wholly diastrophic, altho somewhat aggraded. Where the Rift hugs the steep northeast flank of the Santa Cruz Range as far as Wright Station, and the similarly steep southwest flank of the same range from Wright to Chittenden, it is difficult to avoid the conclusion that these steep mountain flanks are in reality degraded fault-scarps, and are, therefore, the walls proper of a great asymmetric Rift valley. The same conclusion applies to the steep north flank of the San Rafael and San Gabriel Ranges, on the south side of Mojave Desert. The complete discrimination of effects of diastrophism and erosion in the larger features of the relief associated with the Rift will require many years of patient field work.

With regard to the minor features which characterize the Rift in detail, thruout its extent, the discrimination is less difficult chiefly because the diastrophic effects are of comparatively recent date and their distinctive features are not yet obliterated by the ravages of erosion. These consist chiefly of scarps, low ridges, and sinks or ponds. In many cases it is apparent that both erosion and aggradation are controlled by these minor features, and that the latter tend to become obliterated. These minor scarps, ridges, and sinks are not referable to any single earth-movement, but are referable to a recurrence of movement on the same general line. In the southern Coast Ranges the observations of Fairbanks show that one of these movements was of exceptional importance. By its displacements and disturbances of the surface were effected which dwarf all similar events in historic times. For miles at a stretch the earth, upon one side or the other of the fault line, sank, giving rise to basins and to cliffs 300 to 400 feet high. These features, in the opinion of Fairbanks, who personally examined them, were the result of one movement. This displacement probably occurred not less than 1,000 years ago. It is certainly older than the great trees growing upon the ridges and hollows formed by it. Since then it is probable that numerous displacements of less extent have taken place, but the geomorphic effects of the smaller movements have, in some considerable measure, been effaced. Since the settlement of the state, the strain in the earth's

crust has continued to manifest itself, and several slight movements have been observed by residents of the country. In 1857 there was a movement extending from San Benito County probably as far as San Bernardino Valley. The earthquake caused by this movement was not less severe than that of 1906, but we have unfortunately no measure of the extent or direction of the displacement. In this southern region described by Fairbanks, the displacements, even from the first, do not appear to have been of such a nature as to give rise to a continuous cliff or scarp upon either side of the fault; and this observation is generally true throughout the Rift. In one place the scarp faces southwest, in another northeast. In other places the vertical displacement has been very small and the scarps correspondingly insignificant. In several places, as, for example, at Fort Ross and between Mussel Rock and San Andreas Lake, displacements have occurred on subparallel lines, giving rise to opposing scarps, as if a wedge of ground, perhaps several hundred feet across, had dropt in. In such depressions lie the sinks; but the latter are more commonly formed by a low scarp facing up a slope, or by a ridge of surface compression formed across the path of the drainage from a slope. They have also been formed by landslides, which have shown little tendency to move save under seismic impulse.

It remains to call attention, in a word, to the alinement of the Rift with certain of the larger continental features. The Rift is known from Humboldt County to the north end of the Colorado Desert. As a line of small displacements it has not been traced farther; and in the usage of the term it has been understood as terminating at the point where it eluded field observation. But it is by no means certain that, as a larger feature, it does not extend far to the south. The Colorado Desert and its continuation in the Gulf of California are certainly diastrophic depressions, and may with much plausibility be regarded as a great Rift valley of even greater magnitude than the now famous African prototype first recognized by Suess. This great depression lies between the Peninsula of Lower California and the Mexican Plateau. All three of these features find their counterpart in southern Mexico. The Sierra Madre del Sur is the analogue of the peninsular ridge; it lies on the line of its prolongation, and is similarly constituted geologically. Inside of this range, and between it and the edge of the Mexican Plateau, is a pronounced valley system which is the analogue of the Gulf of California.

On this valley-line lies the depressed region about Salina Cruz, well known to be subject to repeated seismic disturbances. On the same general line lies Chilpancingo, the seat of the recent disastrous Mexican earthquake. Following these great structural lines southward, they take on a more and more latitudinal trend; and beyond Salina Cruz the geological structure indicates that this seismic belt crosses the state of Chiapas and Guatemala, to the Atlantic side of Central America with an east and west trend, and falls into alinement with Jamaica. It thus seems not improbable that the three great earthquakes of California, Chilpancingo, and Jamaica may be on the same seismic line which is known in California as the San Andreas Rift.

## THE EARTH MOVEMENT ON THE FAULT OF APRIL 18, 1906,

### THE FAULT-TRACE.

The successive movements which in the past have given rise to the peculiar geomorphic features of the Rift, either directly or by control of erosion, have with little question been attended in every case by an earthquake of greater or less violence. The earthquake of April 18, 1906, was due to a recurrence of movement along this line. The movement on that day was of the nature of a horizontal displacement on an approximately vertical fault plane or zone, whereby the country on the southwest side was moved to the northwest and the country on the northeast side to the southeast. This displacement was manifested at the surface by the dislocation and offsetting of fences, roads, dams, bridges, railways, tunnels, pipes, and other structures which cross the line of the fault. The surface of the ground was torn and heaved in furrow-like ridges. Where the surface consisted of grass sward, this was usually found to be traversed by a network of rupture lines diagonal in their orientation to the general trend of the fault. Small streams flowing transverse to the line of the fault had their trenches dislocated so that their waters became impounded. These and similar phenomena of disruption constitute the *fault-trace*.

The width of the zone of surface rupturing varied usually from a few feet up to 50 feet or more. Not uncommonly there were auxiliary cracks either branching from the main fault-trace obliquely for a few hundred feet or yards, or lying subparallel to it and not, so far as disturbance of the soil indicated, directly connected with it. Where these auxiliary cracks were features of the fault-trace, the zone of surface disturbance which included them frequently had a width of several hundred feet. The displacement appears thus not always to have been confined to a single line of rupture, but to have been distributed over a zone of varying width. Generally, however, the greater part of the dislocation within this zone was confined to the main line of rupture, usually marked by a narrow ridge of heaved and torn sod.

The amount of the horizontal displacement, as measured on dislocated fences, roads, etc., at numerous points along the fault-trace, was commonly from 8 to 15 feet. In some places it exceeded this and at one place it was as much as 21 feet. Toward the south end of the fault the amount of displacement was notably less and finally became inappreciable. Nearly all attempts at the measurement of the displacement were concerned with horizontal offsets on fences, roads, and other surface structures at the point of their intersection by the principal rupture plane, and ignore for the most part any displacement that may be distributed on either side of this in the zone of movement. The figures thus obtained may, therefore, in general be considered as representing a minimum for the amount of differential movement. In one or two cases, however, when the displacement has been measured on soft ground subject to slumping, and the measured offset is higher than usual, the results may be in excess of the true crustal displacement.

Besides this horizontal displacement of the crust, there was also, particularly in the region north of the Golden Gate, a distinct **uplift** of the country to the southwest of the Rift, relatively to that on the northeast. This differential vertical movement was made

manifest by the appearance of low, abrupt fault-scarps, ranging from less than a foot up to 3 feet. Many of these occurred along the slope of somewhat degraded fault-scarps due to former movements, and served to revivify them. In other cases the new scarps have been developed on slopes where no trace of a previous scarp can be detected. The low scarp which was formed on April 18 is by no means a continuous feature, but appears at a great many places not widely spaced along the fault-trace, extending often for hundreds of yards at a stretch, with intervals where no abrupt scarp can be detected. In the latter places it is probable that the differential vertical movement has been distributed over a zone of some width, underlain by formations in which the deeper seated fracture would be taken up by plastic deformation. The scarp almost invariably faces the northeast, but a few cases have been noted in which a fresh scarp on the fault-trace faced the southwest for a short distance. These will be mentioned more particularly in the detailed descriptions which follow. Associated with the fault-trace, it is quite common to find secondary or induced movements of the soil, particularly on steep slopes. These partake of the nature of landslides, and very commonly exhibit the characteristic landslide scarp. This is usually, however, easy to distinguish from the scarp on the fault proper, or on the auxiliary cracks, since it lacks evidence of horizontal displacement, and the broken sod is not traversed by diagonal, torsional cracks.

The differential displacement of the earth's crust above indicated occurred only on the northern portion of the Rift. South of San Juan, in Benito County, there is no indication along the Rift in the shape of rupture of the soil, or the dislocation of transverse structures, which points to the displacement of the underlying formations. It is not, however, to be certainly inferred from this that there was no deep-seated rupture south of that point. Many earthquakes are known which are referable to sudden slips in the earth's crust for which there is no corresponding rupture at the surface. It is probable that the slip, which is so manifest as a surface rupture to the north of San Juan, was continued as a subsurface movement for many miles south of that point.

North of San Juan the displacement on the fault-trace has been followed practically continuously to a point on the northern coast of California a little beyond Point Arena, a distance of 190 miles. At this point the fault-trace as a continuous feature passes out to sea, and the evidence of displacement is lost. At Shelter Cove, in southern Humboldt County, however, where as previously stated the Rift features appear again, evidence of displacement due to movement on April 18 is also found. The doubt as to whether the Rift in Humboldt County is continuous with that which leaves the coast near Point Arena, of course also applies to the question of the continuity of the rupture on the day of the earthquake. If we assume that the line of rupture is continuous thruout, then its full extent from San Juan to Telegraph Hill is about 270 miles.

Beginning with southern Humboldt County, a somewhat detailed account will now be given of the phenomena of the displacement which occurred on April 18, 1906.

#### HUMBOLDT COUNTY.

We are indebted to the observations of Mr. F. E. Matthes for our knowledge of the facts concerning the portion of the coast from Shelter Cove northward. The low headland north of Shelter Cove, known as Point Delgada, is traversed by several fissures trending roughly parallel with the general sweep of the coast and presenting essentially the same surface appearance as the fault fractures observed in Sonoma and Mendocino Counties. While it has been found impracticable to demonstrate by actual measurement the existence of a horizontal displacement along any of these new fissures — in the absence of fences or other objects of sufficiently defined outline — yet it has seemed warranted to regard them as true fault or shear fractures, to be classed in the same



category with those found farther south, merely on the strength of their superficial resemblance.

The effects of a horizontal shear on thick grass sod in open country, as observed in a number of localities along the zone of faulting in Sonoma and Mendocino Counties, are as follows: On fairly level ground, where conditions are simplest and no vertical movement is evident, the sod is torn and broken into irregular flakes, twisted out of place and often thrust up against or over each other. The surface is thus disturbed over a narrow belt, whose width apparently varies with the magnitude of the displacement. Along the main fault, where the throw amounts to 10 feet or more, a width of 5 or 6 feet is not uncommon; on the secondary fractures, where the throw does not exceed a foot, the belt is generally only a foot wide. Whatever the width of the belt, the sod within it, as well as the unconsolidated material underneath, appears loosened up and not compact. It consequently takes up more space than before it was disturbed, and the surface of the belt is therefore slightly raised above the level of the ground, from an inch to a foot or more, according to the magnitude of the disturbance. Within such a belt there is seldom, if ever, a well-defined, continuous, longitudinal crack, the toughness of the sod precluding a clean shear fracture. Rather, there is a marked predominance of diagonal fractures resulting from tensile stresses.

To sum up, a horizontal displacement produces and may therefore be recognized in grassy country by a fault-trace showing:

1. The disturbance of the sod over a narrow belt.
2. The generally raised surface of this belt.
3. The absence of a single continuous, longitudinal crack.
4. The tearing of the sod along numerous diagonal fractures.
5. The twisting and thrusting of sod flakes against and over each other.

It was mainly by the aid of these criteria that the fault lines in the vicinity of Shelter Cove were determined as fault or shear fractures, distinct from the innumerable cracks due to the settling of earth masses consequent upon the jar of the disturbance. In practically all of these the sod had been ruptured by mere tension, or tension accompanied by more or less vertical shearing. Furthermore, as will presently appear, the location of the fault fractures was in many instances facilitated by their association with the characteristic fault topography observed all along the line.

What appears to be the main fault-trace was first observed in the bottom of Wood Gulch, where it runs immediately along the wagon road for a hundred feet or more. It was thence traced south to its southern terminus on the beach of Shelter Cove, and then north across Humboldt Creek up Telegraph Hill. Subsequently several apparently detached lines of a similar character were discovered in the neighborhood of the main fault, as shown on the sketch map. Beginning at the south end, this line may be traced as follows:

On the beach of Shelter Cove, 100 yards west of the frame hut of Snider (at the mouth of Deadman Gulch), the fault passes thru the bluffs obscured by dislocated masses of dark conglomerates. From the top of the escarpment, however, it is easily traced for some distance down. The approximate contour map of the fault (fig. 10) sufficiently describes the topography here. A notable feature is a small elongated pond on the steep hillside, walled in by a small ridge. Thru this the fault-trace passes longitudinally. Continuing north, the line remains east of the upper valley of Wood Gulch until it joins the wagon road in the bottom. The line is by no means straight, as the bearings on the map indicate. A pronounced angle in its course exists at *A* (fig. 10), and the coincidence in this change of azimuth with the abrupt topographic change at this point is strongly suggestive of a hade to the west. Near the loop in the road at *B* the fault is easily recognized, except where the road has been repaired. The fault-trace here passes thru a

characteristic little gap or saddle (plate 31A), and south of *B* follows closely an old fault line, with a slight upthrow on the west. North of the road the fault-trace follows a ravine for some distance, then passes along the west side of a low ridge, as indicated in the contouring, and finally drops down to Humboldt Creek. Thence it ascends the

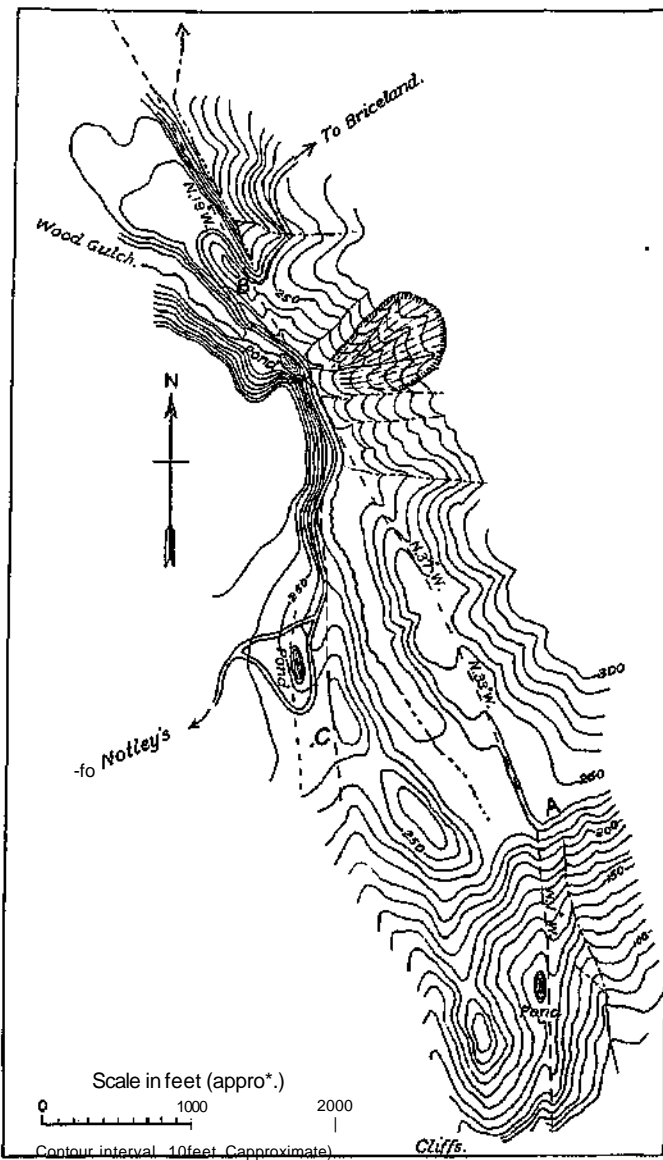

FIG. 10.—Map of country traversed by fault to north of Shelter Cove, Humboldt County.

impression that it past close to King's Peak an ascent of this mountain was made, but without result.

Of the auxiliary cracks, the first one, *C* (see fig. 11), is a less pronounced disturbance than the main fault-trace, passing thru a depression bordered on its east side by a low scarp due to former faulting. A small pond encircled by the road lies on this fault-trace. Its bearing (not measured) is such as to make the line converge toward the main fault-trace and intersect the same in the vicinity of the pond in the bottom of Wood Gulch. The horizontal displacement along this line is probably small, much like that on the

south slope of Telegraph Hill, following for a considerable distance a characteristic fault feature on the steep brushy spurs indicated in plate 31D. Immediately south of the summit of Telegraph Hill the disturbance is the most pronounced, being accompanied apparently by an upthrow on the west side, resulting in a sharp-crested ridge some 4 feet high. It is possible, however, that this ridge is not the result of the recent disturbance, but of a former one, modified into a more acute form by the shaking off of the sod. (See plate 31c.) From the summit of Telegraph Hill a bearing was taken over the entire length of the line down to Shelter Cove: N. 25°W. Projecting the line north from the hill on the azimuth, it appears to head for a number of high mountains of the King's Peak Range, altho no visible traces of the disturbance are found north of Telegraph Hill. Immediately north of its crest is the upper end of a great hopper-like landslide, clean swept for over a thousand feet. The fault-trace is entirely obliterated by this slide. The exact location of the fault north of Telegraph Hill was not ascertained. Under the



A. Fault-scar passing thru saddle at head of Wood Gulch, looking south-southeast, F.E.M.

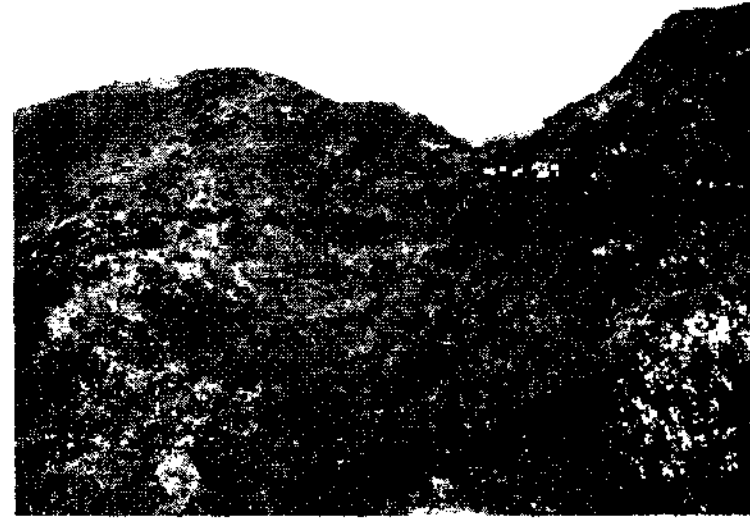

B. Auxiliary fault-trace following old scarp in saddle between Wood Gulch and Humboldt Creek. F. E. M.



C. Looking south-southeast from Telegraph Hill along fault-trace marked by sharp-crested ridge in foreground, with upthrow of  $4\pm$  feet, F.E.M.

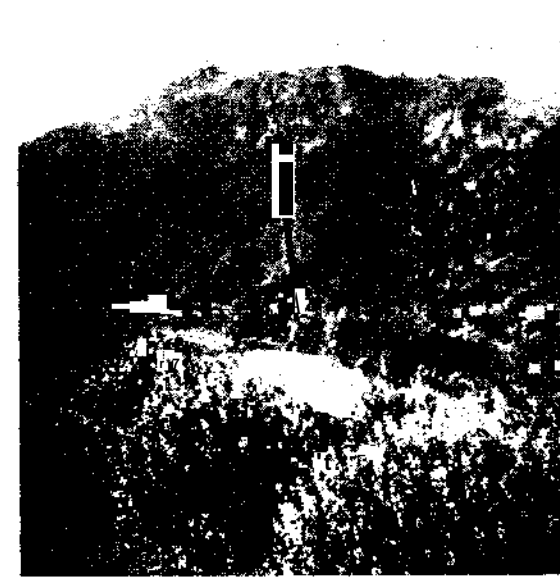

D. Looking north-northwest along main fault marked by small ridges on spurs of Telegraph Hill. P. E. M.

auxiliary fault cracks accompanying the main fault-trace in Sonoma and Mendocino Counties, which it greatly resembles in surface characteristics. Another line of some prominence was discovered near the mouths of Humboldt Creek and Wood Gulch. As fig. 11 indicates, this fault-trace, *D*, follows for some distance along Wood Gulch, then crosses over to the little gorge of Humboldt Creek (plate 31B), which it follows out to its mouth. The divide at *D* has a marked depression along the line of faulting. The fence cross-

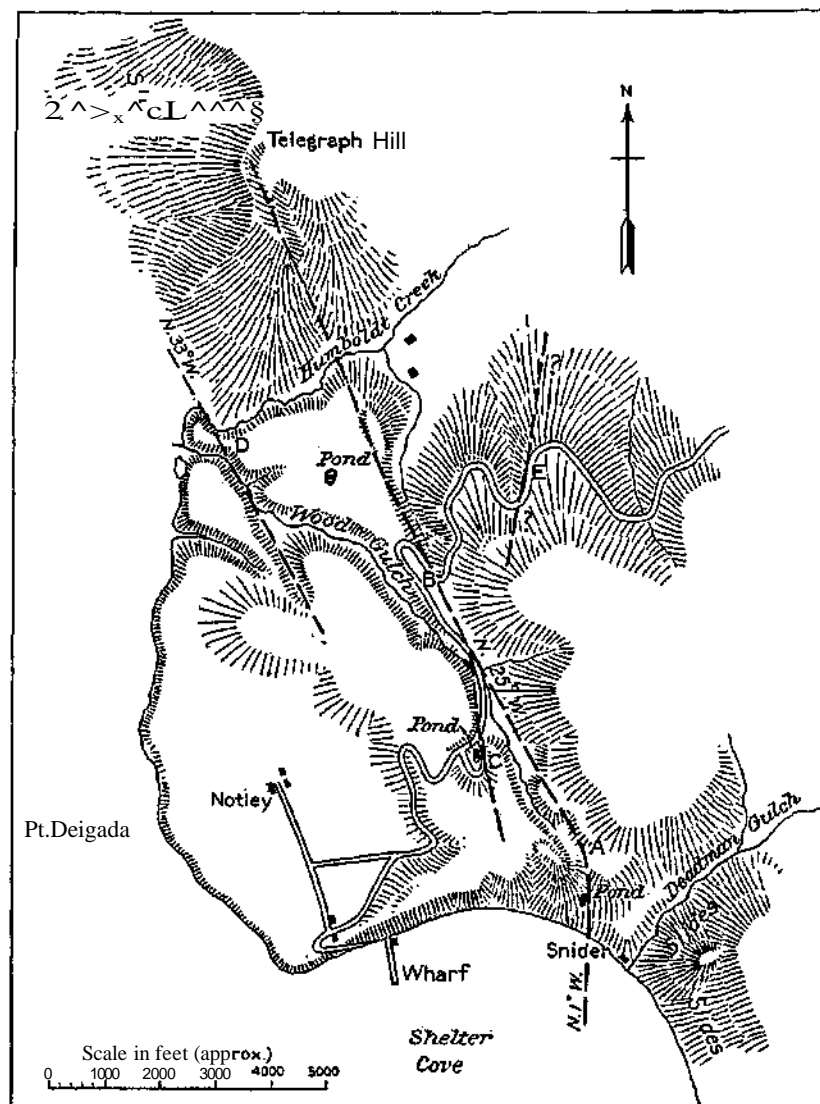

FIG. 11.—Map of country north of Shelter Cove, Humboldt County, showing auxiliary faults in relation to main fault.

ing it shows no signs of horizontal shifting. It was not learned whether or not it has been repaired since the quake. Tracing it to the south up over the grassy hills, it is found to disappear somewhere near the head of the little gulch shown on the map. A third line was found along the wagon road at *E*, following an old fault ridge descending the hillside on a slant. Its probable connection with the *C* line suggests itself.

In search of the north end of the fault, the following itinerary was made: From Telegraph Hill northeast to the old ridge road, to Albert Boots' ranch, thence up King's

Peak and its sister peak to the north; thence to Upper Mattole and Petrolia, *via* the stage road; from Petrolia north across the North Fork of the Mattole River, and along the same over the high terraces to the north branch of the North Fork; also westward over the hills, north of the river, to the summit of the last hill next to the coast, and back along the river; from Petrolia south to the bridge, and up the hills south of the town to the top of the great slide existing there; south to Cummings<sup>5</sup> ranch; and thence across Cooskie Range, between Squaw Creek, Spanish Creek, and Cooskie Creek. It was on the high bald spurs between Cooskie, Randall, and Spanish Creeks, close to the coast, that old Rift topography was for the first time encountered in this district. Several small ponds and ridges are found both on the spurs and close to their bases next to the beach. No sign, however, of a fresh disturbance could be found here.

Finally, an excursion up the coast to Cooskie Creek and then south along the beach to Shelter Cove served to encompass the entire area under investigation. A short side trip was made up the creek flowing from King's Peak, but nothing definite could be learned regarding the location of the fault. South from Hadley's ranch at Big Flat, the precipitous mountain slopes have been destroyed by extensive and high landslides, the dislocated materials of which have frequently advanced out upon the beach in the form of glacier-like tongues. The waves at high tide have since nipt these protruding masses and truncated them at their ends. Many of the slides occurred apparently on the sites of older ones. Their continuity and extent made the discovery of the fault in this neighborhood impracticable. The prevalence of great slides along the coast, back inland, seems to suggest the possibility of the fault curving along the coast, and gradually leaving it south of the Big Flat Ranch. In the belief that this might be the case, and that the fault might continue closely along the coast for some distance, to reënter farther north, a visit was made to the great slide at Cape Fortunus — the most extensive slide along the north coast. No trace of the fault could be discovered here, however. No visit was made to Cape Mendocino nor to Needle Rock, a small promontory south of Shelter Cove. As seen from the cove, this rock has a pronounced saddle suggestive of faulting. Should the fault-trace run thru it, it would have a very strongly curved course, parallel with the coast.

Mr. Matthes' account of the conditions in the vicinity of Shelter Cove may be supplemented by the following note by Professor A. S. Eakle:

Shelter Cove appears as a broad slope spreading out and forming a circular coast line of about 2 miles in length, with a flat plain 6 to 10 feet above the sea. The ocean is constantly wearing away the land and no beach surrounds it. Half a mile from the ocean the land begins to rise in grassy hills which are abruptly cut off from the high mountains behind by a deep canyon. The formation of the cove indicates that it has been broken off from the hills above by a huge landslide, perhaps by a former earthquake. The gorge which separates it from the mainland is on a line with the general coast. On the south side of the cove there are three parallel deep gorges which extend a short distance into the hills; and their continuation over the hills is shown by slight depressions which appear to have been clefts which have become almost filled with the wash of the hills. Along all these lines of weakness fissures were opened and the ground subsided 2 to 3 feet. Cross fissures running from one depression to another are also present. The trend of the main fissures followed the coast, which is northwest-southeast. On the high crests of the Cooskie and King Mountains, which border the coast north of the town, fissures and landslides were reported by ranchers looking for cattle, but this region was not visited. In the range south of the cove landslides were also reported and a photograph of a large one was taken. The rocks of the coast are sandstones and black shales, and the hills and plain of the cove were composed of blue and yellow sandy clay, evidently derived from the decomposition of the shales.

## POINT ARENA TO FORT ROSS.

For the course of the fault and the phenomena of earth movement along it for the stretch of 43 miles between the mouth of Alder Creek and the point on the shore south of Fort Ross where it passes beneath the Pacific, we are again indebted to Mr. F. E. Matthes, who, on behalf of the Commission, made an examination of this territory. In the vicinity of Fort Ross, however, several observers contributed notes as to the phenomena there. For this entire distance, the rupture of the ground and its differential displacement are strongly marked and, except for the occasional local obscuration of the phenomena by brush and timber, are easily traced. The fault-trace enters the shore less than half a mile north of the mouth of Alder Creek and crosses with a course of  $S. 28^{\circ} E.$  the bench-land, or wave-cut terrace, to the banks of the creek about 500 feet in from its mouth (fig. 12). Over the surface of the bench it is marked by characteristic rending and heaving of the sod. At the point where it reaches Alder Creek, the stream bank is rocky and steep, and the course of the crack can be traced down the rocky bluff, tho somewhat obscured by talus. The face of the bluff is shown in plate 32A. On the edge of the bench above the stream cliff (B, fig. 12), there is a rocky knob projecting above the general level. The earth crack passes close to the southwest side of this knob. The hade of the crack on the face of the bluff for a height of about 50 feet is very nearly vertical, but its deviation, if any, from the vertical could not be accurately measured on account of the ragged character of the bluff and the loose rock upon its face. On the northeast side of the rocky knob above referred to, there is evidence of a less well-marked parallel crack, as indicated on the sketch (fig. 12). This also appears on the rocky bluff of the stream cliff, but is less distinct than the main crack.

Southeast of this point, the fault-trace follows the broad stream bed of Alder Creek for nearly a mile, passing beneath a bridge, the wreck of which is shown in plate 32B. In this view, the horizontal offset of the bridge along the fault-line is well shown. It is apparent that this offset is not less than the width of the bridge. On the southwest side of the stream, near the bridge (A, fig. 12), the fault-trace is flanked by peculiar, isolated, rocky knobs similar to that on the northeast side. It is not clear, however, that these rocky knobs have more than an accidental relation to the fault, since they may possibly be residual sea-stacks upon the uplifted wave-cut terrace.

After leaving Alder Creek, the phenomena of surface rupture and displacement were traced thru a series of ranches to the divide passing over to Brush Creek, and down to the vicinity of Manchester. Along nearly this entire distance between Alder Creek and Brush Creek, the line passes thru a series of depressions, swamps, and ponds, the majority of which are not connected with the neighboring streams. Offsets due to the displacement were measured on two fences of Mr. E. E. Fitch's ranch, and the amount of movement was found in each case to be 16 feet, the southwest side having moved relatively toward the northwest. The vertical displacement was, as a rule, quite small; only in a few places did it amount to a foot, presenting a low scarp of that height facing the northeast. To the north of Manchester, an east-west fence line was offset in three places,

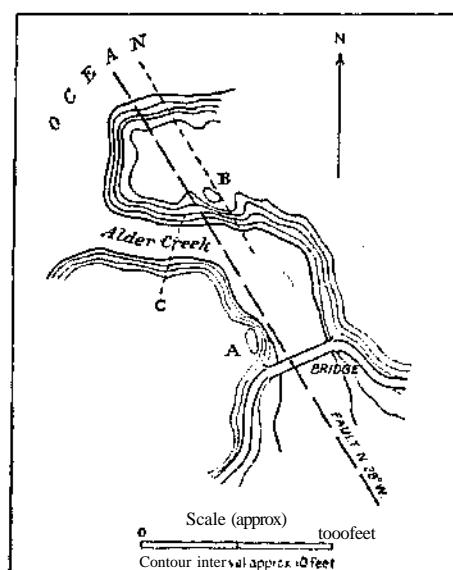

FIG. 12. — Map of mouth of Alder Creek, showing position of fault-trace.

the zone of dislocation being in low, marshy ground. At another place near Manchester, where an east and west fence follows the north side of a wagon road, both fence and road have been offset as shown in plate 32D. In both cases the relative movement on the southwest side was to the northwest. The dairy barn on the ranch of Mr. E. E. Fitch stood astride the line of movement and was demolished by the torsion to which it was subjected. The wreck of the barn is shown in plate 32c. At two places along the stretch between Alder and Brush Creeks the bearing of the fault-trace was measured, the readings being N. 28° W. and N. 30° W.

Southeasterly from Manchester the line of dislocation passes over the dividing ridge between Brush Creek and Garcia River, presenting the same general features. The upthrow is distinctly on the southwest side, but amounts, as a rule, to only a few inches. The horizontal displacement was measured on a line fence south of the divide. The fence is offset in two places. The principal displacement amounts to 13 feet; while on the minor offset, a little to the east, the displacement is 2.5 feet. The relative movement in both offsets is in the same direction, making the northwesterly displacement of the southwest side 15.5 feet. This fence is shown in plate 33A. South of this divide the main fissure passes thru a depression immediately east of a prominent knob projecting south from the divide; while a subordinate fissure traverses featureless hillsides from 100 to 150 feet farther east.

For some distance up the Garcia River from the point where the Rift intersects it, the line of dislocation traverses the flat alluvial bottom land, crossing and recrossing the stream bed. At David Jones' ranch it leaves the bottom and ascends obliquely the side of the valley; and from this point to its head waters it remains on the western side of the valley. Its path is thru a belt of ridges and swamps. Part of the way there are two sets of ridges, the lower or eastern of which coincide with the new line of rupture. Looking along the valley, the more prominent of these ridges appear as notable features of the transverse profile. Opposite Button's ranch, the line is found about 500 feet west of the river, and about 60 feet up on the valley slope. It crosses a road and fence here, producing offsets of 10 feet in both, in the same sense as before noted. At the head of the Garcia River, the fault-trace passes thru a low saddle into the valley of the Little North Fork of the Gualala River.

Down the Little North Fork, the fault-trace follows the axis of the valley on its west side; at a point 1.5 miles north of its junction with the North Fork it runs lengthwise for over 100 yards with the grade of an abandoned logging railroad, tearing the same to pieces. Interesting evidence of the condensation or shortening of the ground in this vicinity is afforded by the buckling of the rails as seen in plate 33D. Here the main line of dislocation lies about 100 feet to the east of the track in the stream bed. The effect of the movement was to shorten the steel rails either by buckling or telescoping after the snapping off of the fish plates. The small trestle in the distance is traversed at an acute angle by an auxiliary line of dislocation and is similarly shortened. At the locality shown in plate 33c, the buckling in the foreground resulted in the breaking of the rails. Similar instances of the shortening of the steel are shown in the distance. Here the main line of dislocation of the earth lies about 50 feet to the east of the track, and parallel with it. Plate 33B is a nearer view of the trestle above referred to. Below this point the fault-trace lies in the stream bed for some distance, crossing the North Fork at a point 200 feet east of its junction with the Little North Fork. Two lines of faulting appear here, both of which caused considerable damage to the railroad track; but the latter having been repaired before the elate of Mr. Matthes' visit, no measurements of offsets were obtainable.

From this point southeasterly, evidence of dislocation along the line of the Rift, in its course up the valley of the South Fork of the Gualala, is obscured by the dense brush to



A. Rocky stream bluff 50 feet high on north side of Alder knoll. Fault vertical on left of knoll; auxiliary fault on right of knoll. F. E. M.

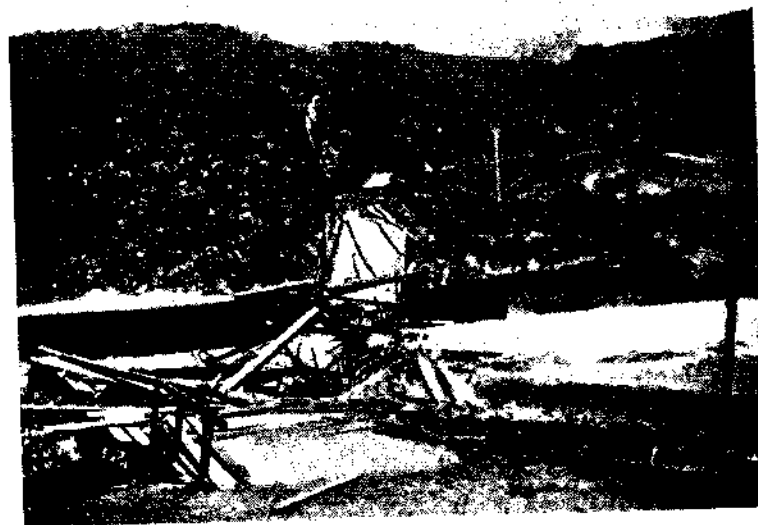

B. Fault passing under bridge over Alder Creek. Bridge displaced not less than its width. F. E. M.



C. Barn of E. E. Fitch, north of Manchester. Astride the fault. F. E. M.



D. East-west fence 0.25 mile north of Manchester offset by fault. Fence and road were formerly straight and have been repaired. Looking east. F. E. M.



a point east of Stewart's Point. Here the line runs on the lower side of a double series of low ridges, interspaced with elongated swamps, and all trending parallel with the river. (See fig. 13.) Its bearing is N. 33° W.; altho only short sights could be obtained on account of the timber and brush. The bearing noted is nearly in line with the axis of the valley of the South Fork of Gualala River. The amount of dislocation could be estimated only in a rough way from the offsets in the road leading east from Stewart's Point to Lancaster's ranch. A few neglected picket fences gave doubtful results, the alinement of the pickets having been previously disturbed by forest fires, fallen trees, etc. The horizontal movement is distributed over two strong, and one or more dim, lines of

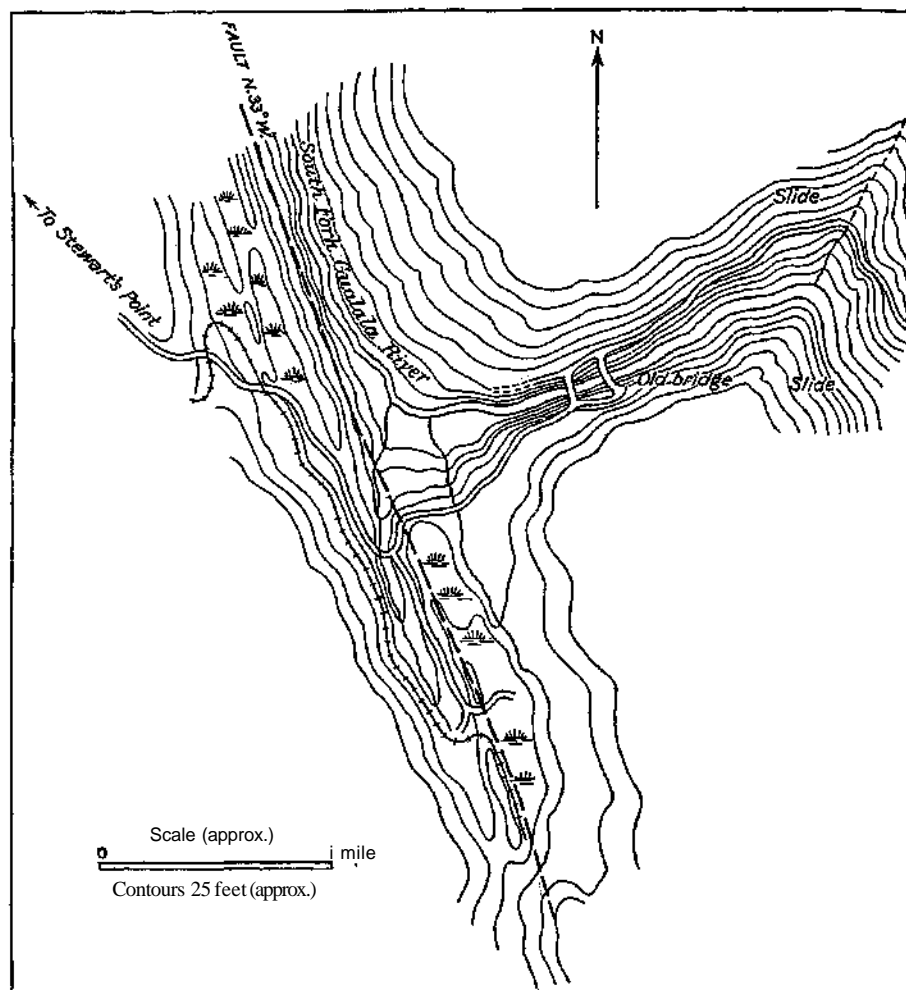

FIG. 13. —Map of valley of South Fork of Gualala River, showing relation of fault-trace to geomorphic features.

faulting, all of them producing offsets ranging from a few inches to several feet. The total displacement apparently did not reach 8 feet. As will be apparent from fig. 13, a logging road runs southeast parallel with the fault for 0.75 mile, and then crosses the same at an abrupt turn. It so happens that the road at this point has been cut thru one of the narrow ridges referred to, the depth of the cut being about 7 feet. The movement on the fault has practically closed the cut, so that it is now barely passable on foot. The bridge over the South Fork of the Gualala River, 3 miles east of Stewart's Point, had

its floor and end panels bent and the tension rods in the last two panels were buckled and twisted.

The upthrow on the fault east of Stewart's Point is on the west side; but farther up stream, where the fault runs along the steep west side of the valley below Casey's ranch, the upthrow is apparently on the east side. The foot trail from Casey's ranch to the river follows a marked longitudinal depression in the steep slope for 100 feet, and it is along the abrupt west side of the small ridge flanking the hollow (see fig. 14) that the fault-trace is located. The upthrow measures fully 2 feet, while the height of the ridge above the hollow varies from a few feet to more than 10 feet. The depression pitches to the north and is drained by a tiny brook. The fault-trace happens to coincide with the latter at a point where the trail crosses the watercourse over a rough wooden bridge. The horizontal movement along the fault practically destroyed the bridge. No measure of the displacement could be obtained here, but the indications are such as to warrant the belief that it did not amount to 15 feet, and that probably some of the horizontal shear had been distributed over minor lines of displacement higher up the slope, and marked by landslides. These landslides above the depression in which the

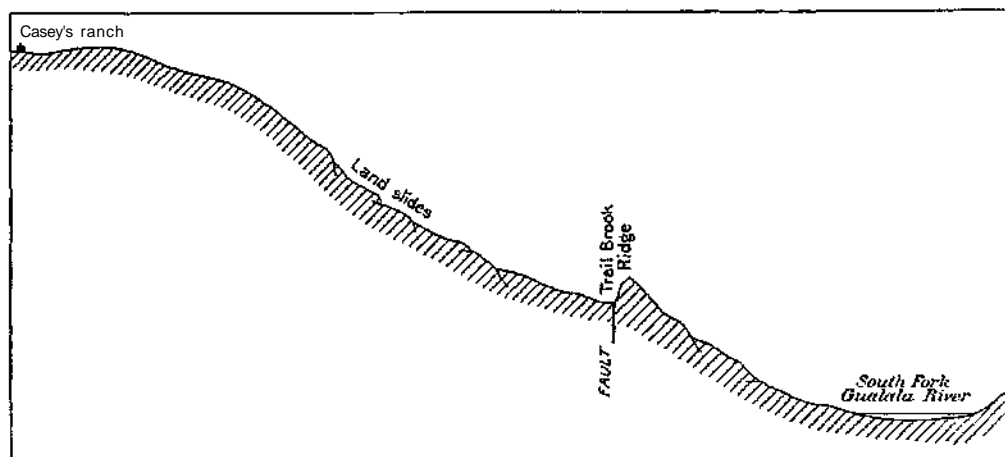

FIG. 14.—Profile of southwest side of South Fork of Gualala River, showing relation of fault to geomorphie features.

fault-trace lies are an important factor in the interpretation of the phenomena. It is easily possible that the scarp looking southwesterly over the depression referred to does not represent the real movement on the fault plane, but is a landslide effect. In any event, the proximity of the landslide weakens very much any judgment that might be formed, implying a reversal of the vertical movement which normally prevails along the line of the fault.

From Casey's ranch southeast, detailed observations were found to be impracticable owing to the dense tangle of brush and fallen timber. The ridge between the upper stretch of the river and the coast is crossed by the fault-trace thru a swampy saddle above Plantation House, and the fault-trace traverses the swamp. Plantation House stands practically on the line of disturbance, about midway in a zone 270 feet wide traversed by six roughly parallel lines of rupture. The general bearing of the principal line was found to be N. 38° W. Southward the main fault passes thru a series of swampy hollows along an abandoned road, now impassable because of the cracks thru it. The line was traced south for 2 miles, its general appearance being found to remain the same thruout. There is a marked upthrow along its west side, not exceeding a foot at any place. Where

it crosses the stage road at the Plantation House, the vertical displacement on the main fault measured 6 inches; that on the secondary lines did not exceed an inch.

At Buttermore's ranch, about a mile east of Timber Cove, the displacement is distributed over three fissures, the principal one running 30 feet west of the dwelling. It intersects three fences, all of which show offsets of about 8 feet. The original crookedness of the fences and the repairs made since the earthquake make the accurate determination of the displacement impossible. The fault-trace was followed for some distance south and north from the ranch thru the forest, and found to follow the swampy depressions most of the way with low scarps or ridges to the west. The ranch and its fields lie for the most part in a broad swampy saddle. The upthrow in this neighborhood is on the west side, not exceeding 15 inches anywhere.

#### FORT ROSS.

North and south of Fort Ross, the phenomena of displacement are well displayed, both on the open-terraced coastal slope and in the timber. The rupture follows for the most part a single well-defined line in the path of the old Rift, coinciding in many places with ancient scarps and the slopes of low ridges. (See plates 35A and 36D.) The fault-trace is commonly marked by a ridge of heaved sod with diagonal cracks as illustrated in plates 35B and 36B. New scarps occur as shown in plates 36c, and 38A, B, as well as accentuations of old scarps. There are, however, several subparallel cracks. Two of these, having each a length of about 150 feet, lie to the west of the main line at a point 1,250 yards northwest of Doda's ranch-house, one 50 and the other 100 feet distant from the main crack and disposed *en échelon*. Within 300 yards to the southeast of this are two short cracks still closer to the main one, and springing from it, at about 450 yards northwest of Doda's ranch-house, is a parallel crack 440 feet in length and 60 feet from the main line. In this case the scarp appears upon the auxiliary crack, and not upon the main line of rupture. Between the short discontinuous crack and the main line is a swampy depression. On the southeast side of the ravine, southeast of Doda's house, the main crack is paralleled by two subordinate cracks, one on each side. That on the southwest side is about 250 feet long and 50 feet from the main line. It has a low scarp facing northeast, but not so pronounced as that on the main line of rupture. The crack on the northeast side of the main line has a length of about 1,125 feet and converges upon the latter toward the northeast. At its northwest end it is 190 feet from the main crack and at its southeast end only 50 feet distant. It has a low, discontinuous scarp facing northeast.

In a distance of 7,250 feet measured along the line of the fault, there are twelve stretches of scarp ranging in length from 125 feet to 1,000 feet, counted both on the main and on the auxiliary cracks and aggregating 3,000 feet in length. Of these eight face northeast and four southwest. The eight scarps facing northeast aggregate 2,250 feet in length, while the four facing southwest aggregate 750 feet. Two of the southwesterly facing scarps, however, aggregating 375 feet in length, are on the descent to the ravine southeast of Doda's house, where there is considerable sliding of the ground, and they may possibly be accounted for as secondary features due to landslides. The other two scarps facing the southwest are unexplained. They are abnormal and are so exceptional that they scarcely weaken the general conclusion that the vertical component of the movement on the fault was upward on the southwest side. The amount of this vertical movement in the vicinity of Fort Ross probably does not exceed 3 feet. In the first hasty examination of the ground, it appeared as if the amount of vertical movement might have been as much as 4 feet. This impression was due to the fact that in places preëxisting scarps were closely followed by the fault-trace, and a sufficiently careful discrimination was not made between the proportion of the scarp due to the new displacement, and that due to

earlier movements. A review of the facts indicates that the addition to the height of the old scarps and the total elevation of the new ones rarely, if at all, exceeded 3 feet. In general it was less than 2 feet.

The distribution of the line of faulting for a typical stretch of the Rift near Fort Ross,

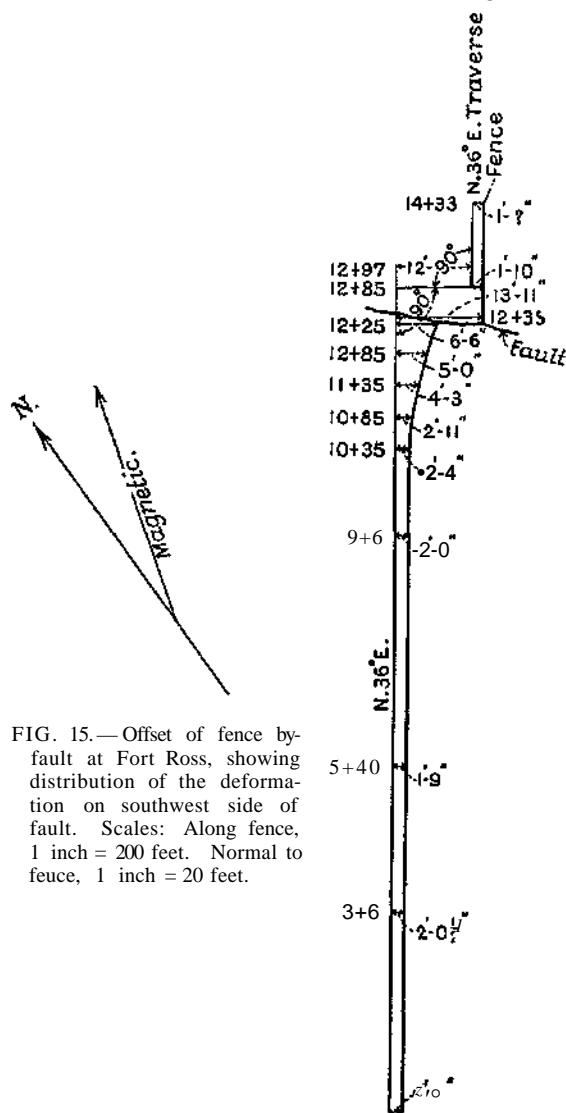

FIG. 15.—Offset of fence by fault at Fort Ross, showing distribution of the deformation on southwest side of fault. Scales: Along fence, 1 inch = 200 feet. Normal to fence, 1 inch = 20 feet.

the auxiliary cracks, the disposition of the scarps upon these, and the relation of the whole to the old Rift features, are well shown on map No. 3 by Mr. F. E. Matthes. The horizontal displacement is also indicated on the map, but this needs more detailed statement.

On the line of the fault, about 300 yards northwest of the road from Sea View to Fort Ross, a steel water-pipe was dislocated by the earth movement, and found to be offset 8 feet, the southwest portion having moved northwesterly. This of course affords only a minimum measure of the relative movement. Where the road just mentioned intersects the fault-trace, both the road and the bordering fences were offset about 7.5 feet, with a slight sag on the northeast side. The zone of shearing here was from 10 to 20 feet wide. A wagon road on the Call ranch, south of the one above referred to, was offset 12 feet 3 inches, the line of dislocation being marked by an open fissure in the soil a few feet deep, and several short diagonal cracks, as shown in plate 36c. Another offset fence is shown in plate 36A, the displacement being here 8 feet at the fault-trace. The effects of the earth movement in the timber to the south of this are well shown in plate 34A. Several large trees standing on the fault line were split or torn asunder. The offset of the south line fence of the Call ranch was carefully surveyed by Mr. E. S. Larsen, and the

results of his survey are shown in fig. 15. The bearing of the fence is N. 36° E. He reports that for the first 1,000 feet from the southwest end of the fence the greatest error in alinement was about 1 inch, and that practically there was no deformation in this stretch. In the next 125 feet going northeast there was found a deviation from this alinement of 4 inches to the southeast. In the next 50 feet the deviation in the same direction was 7 inches more. In the next 140 feet the deviation in the same direction was 3 feet 7 inches more. Then came the fault-trace with an abrupt displacement of the fence of 7 feet 5.1 inches. Northeast of the fault-trace the fence retained its line very well. In 100 feet it was out only 1 inch. Beyond this it enters the timber and its course is somewhat influenced by the larger trees, but maintains its line within a few inches. These measurements give a total horizontal displacement of 12 feet distrib-



A. Fault-trace in redwood forest near Fort Ross. J. N. L.



B. Dislocation of fence near Fort Boss. J. N. L.



A. Accentuation of old scarp by new fault 1.5 miles north of Fort Ross. J. N. L.



B. Fault-trace on grass-covered slope near Fort Ross. E. L. H.

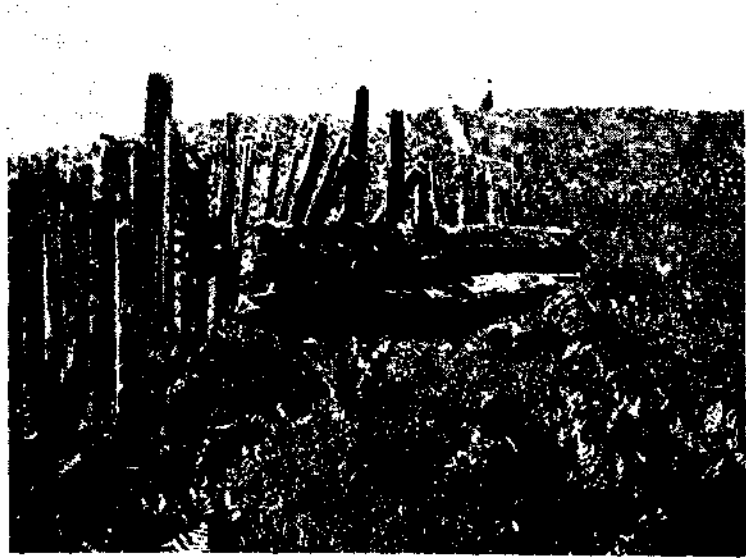

A. Offset of 8 feet on fence a mile east of Fort Boss. R. S. H.



B. Fault-trace and dislocated fence near Fort Boss. B. S. H.



C. Roadway offset 12 feet. New fault-scarp 3 feet high, facing northeast. Above Fort Boss. F. E. M.



D. Accentuation of old fault-scarp by new fault. Near Fort Boas. F. E. M.



A. Offset of stream trench by the fault and ponding of water by the fault-soarp. Doda's ranch, a mile southeast of Fort Boss. A. O. L.



B. The fault-trace a mile northwest of Bolin&s Lagoon, looking southwest! Ikstrates the ridg© phase. G. K. G.



uted over a zone 415 feet in width. Another fence farther southeast on Doda's ranch, having a bearing of N. 36° E., was offset on the fault-line 15 feet; the southwest side, as usual, having moved relatively to the northwest. This fence is shown in plate 34B. One of the most interesting effects of the displacement due to the fault is that seen where the latter intersects a small stream at Doda's ranch-house. The stream flows transversely to the line of the fault, and has a trench across the terrace about 5 feet deep. On the lower or southwest side of the fault, the stream trench has been moved northwesterly about 12 feet, so as to bring a fault-scarp across the entire width of the upper part of the trench and impound its waters in the form of a pool. The result is shown in plate 37A and also on Mr. Matthes' map of the Rift at this place (map No. 3). The impounding of the waters on the line of the fault is interesting evidence of the absence of any open crack.

#### BODEGA HEAD TO TOMALES BAY.

The location of the fault across the neck of land which connects Bodega Head with the mainland was determined by Prof. J. N. LeConte. He reports that on the south side of this neck the main earthquake fissure was found passing about 50 yards west of a house occupied by Mr. Johnson. It could be traced as a multitude of small cracks in the swampy land from the bay to the road, then as a well-defined fissure up the small depression west of the house for 200 yards to where it disappeared in the sand dunes. No trace of it could be detected in the sand dunes, which reach from this point entirely across the peninsula. Only one fence crosses the fissure and this had been repaired so that no measurement of the displacement was possible. The movement was evidently northward on the west side, as was shown by the direction in which the bushes were bent. The vertical movement was about 18 inches, the uplift being on the west side. The sand spit which closes the bay on the south was examined for evidence of movement, but nothing could be detected in the drifting sand.

At the mouth of Tomales Bay there are two points projecting westward from the east shore, and both of these, according to the observations of Prof. R. S. Hoiway, are crossed by the fault-trace. The first is a long, flat sand-spit extending well across the mouth of the Bay just south of Dillon's. The line of the fault was still visible in the sand on June 11, 1906, in spite of the obliterating action of the wind and the recent rains. The line lies near the base of the spit and has a northwest-southeast course. On each side of the crack are crater-like depressions, some of them being double or overlapping. Mr. Keegan, the owner of Dillon's Beach, reported that these craterlets were numerous and distinct. In some instances a great deal of sand and water had been ejected. Others are reported on the southwest side of the fault-trace, from which the belt containing them extends some 70 feet. The craterlets vary in size up to 6 feet in diameter and it is reported that on the day after the earthquake the water which stood in them could not be bottomed by a fishing pole.

About 1.5 miles southeast of this spit is a promontory about 100 feet high projecting into the bay. Some 400 yards from the end of this promontory on top of the ridge is a line of depression with two or three small ponds. The main fault fissure here divides into two cracks, one each side of this depression, which is about 150 feet in width. Standing on this ridge, the line of the fault can be traced at low tide for nearly 1.5 miles across the bottom of the bay to the sand-spit to the northwest, its course in general being parallel to the axis of Tomales Bay. (See plate 38c.) The horizontal displacement where the fault crosses the promontory is about 8 feet, as determined by the line of tall grass at the edge of the little ponds, the westerly side having shifted to the northwest.

## TOMALES BAY TO BOLINAS LAGOON.

BY G. K. GILBERT.

*The Fault-trace.* — The trace traverses the zone of the Rift. Its general course is N. 35° W. and it nowhere departs more than a few hundred feet from the straight line connecting its extreme points. For considerable distances it is a single line of rupture; elsewhere it is divided into parts which separate and reunite; and in yet other portions it is composed of unconnected parts arranged *en échelon*. There are no vertical sections exhibiting hade, but the relation of the trace to sloping surfaces indicates that the fault-plane is approximately vertical.

For considerably more than half its length the surface expression is a ridge from 3 to 10 feet wide and ranging from a few inches to about 1.5 feet high. (See plates 37B and 40A.) The ground constituting the ridge is in fragments, loosely aggregated, so that there are considerable voids. Where pasture lands are crossed the turf is torn into blocks, and these, in conjunction with the cracks which separate them, make up a pattern. This pattern is always irregular and sometimes gives no evidence of system, but usually its lines have a dominant direction, traversing the ridge obliquely, the northern ends of the cracks pointing toward the eastern boundary of the ridge, and the southern ends toward the western boundary. The cracks have resulted from stresses connected with the horizontal faulting, in which the southwest block moved northwest with reference to the northeast block. (See plate 39.)

In other places, and usually for short distances, the surface expression is a shallow trench (plates 40B and 46B), with ragged vertical sides from 2 to 5 or 6 feet apart, and occupied by loosely aggregated fragments of the ground, the pattern of the fragments and interstices being similar to that observed in the case of the ridges. This phase suggests that just below the surface the fault may be somewhat open, so that there has been an opportunity for fragments to drop into it.

In a third phase the ground is not notably elevated nor depressed but is traversed by a system of cracks obscurely parallel one to another and making an angle of about 45° with the general direction of the trace. Their orientation is such that they run nearly north and south. The cracks do not meet, but leave the intervening strips of ground in full connection with the undisturbed ground outside the trace. This phase occurs chiefly in wet alluvium.

There are a few spots where for short distances the surface expression is a simple straight fracture along which horizontal motion took place.

In the detailed descriptions which follow, the first three phases described above will be spoken of as the *ridge phase*, the *trench phase*, and the *echelon phase*.

The most southerly observation of the fault-trace was on the spit separating Bolinas Lagoon from the ocean. Near the west end of the spit its surface is covered by small dunes, and among these the trace was seen in its echelon phase. After a lapse of nine months the drifting of the sand had obliterated most of the cracks, but a few were still visible. Inside the spit lie a number of islands, the largest of which, Pepper Island, has a nucleus of sand (the vestige of an ancient spit), but superficially consists mainly of a fine tidal deposit. In the earlier field excursions the fault-trace was here overlooked by the echelon cracks by which it is represented being mistaken for secondary cracks, but at the present time (spring of 1907) it is easily traced, even from a distance, because the vegetation on the two sides of it has acquired different colors. Unfortunately the camera does not discriminate these colors. (Plate 41A.) The echelon phase here dominates, but the ground east of the trace is depressed about a foot, and this depression has so changed the relation of certain plants to the tides that they now find the conditions of life unfavorable and are dying out. This matter will be considered more fully in another connection.



A. Fault-trace in old depression marked by scarp  $3 \pm$  feet high, with auxiliary scarp above Doda's ranch, a mile southeast of Fort Boss. Looking southwest. F. E. M.

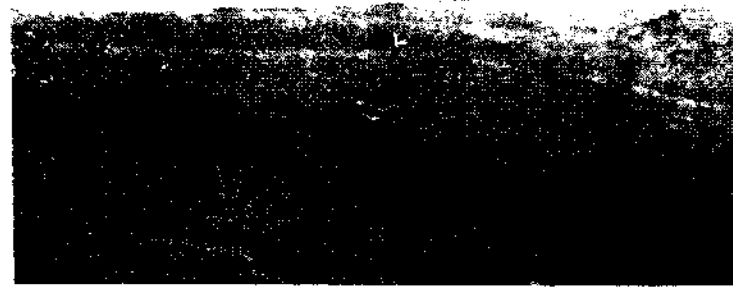

B. Fault-trace marked by scarp  $3 \pm$  feet high on west side, Southeast of Fort Eosg, looking southwest. F. E. M.



C. Fault-trace extending from cliff in foreground across tidal flats of Tomales Bay, near its mouth. E. S. H.



D. Fault-trace between garden and house, Skinner's ranch, near Olema. Before earthquake center lines of path and steps were coincident | afterwards offset was 15 feet 9 inches.

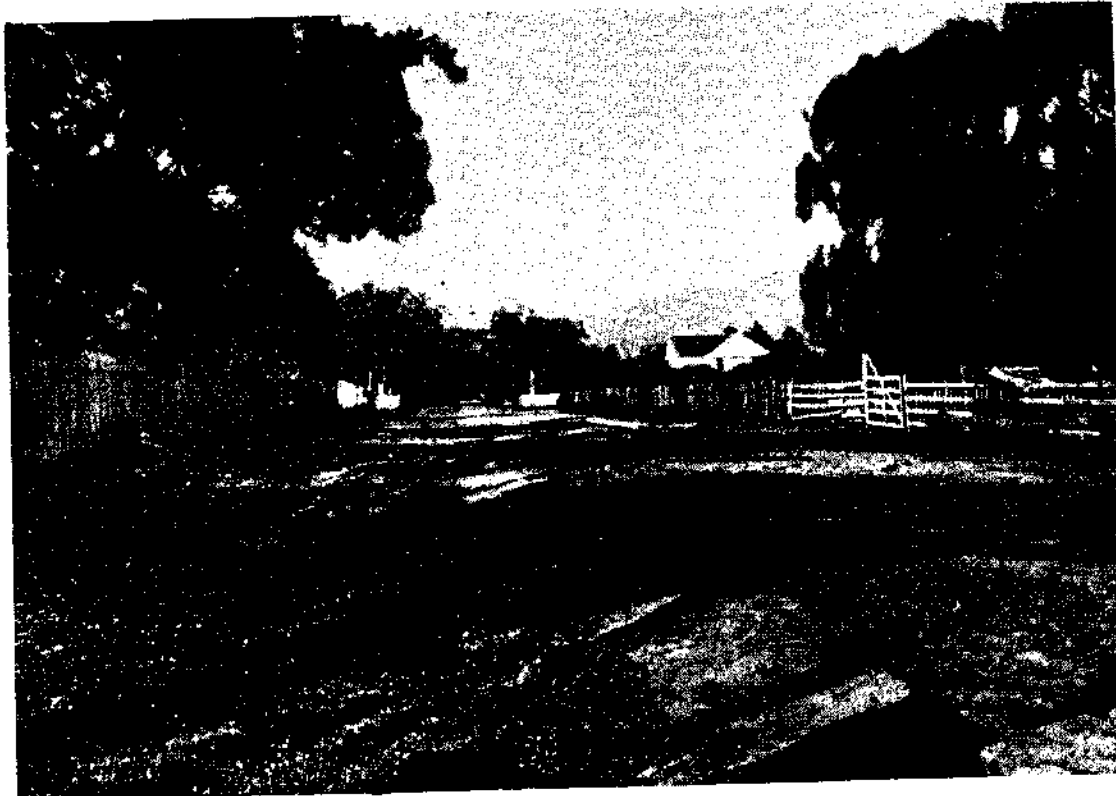

A. Branch of fault-trace in north part of Bolinas. Looking north-northwest. Illustrates diagonal cracks. & K. G.



B. Branch of fault-trace, near Buaditti's ranch. Looking tooth. Illaatrates diageaai cracks. G. K. G.



A. Fault-trace a mile northwest of Olema. Looking northwest. Illustrates ridge phase. G. K. G.



B. The fault-trace west of Olema. Looking southeast. Illustrates the trench phase. G. K. G.

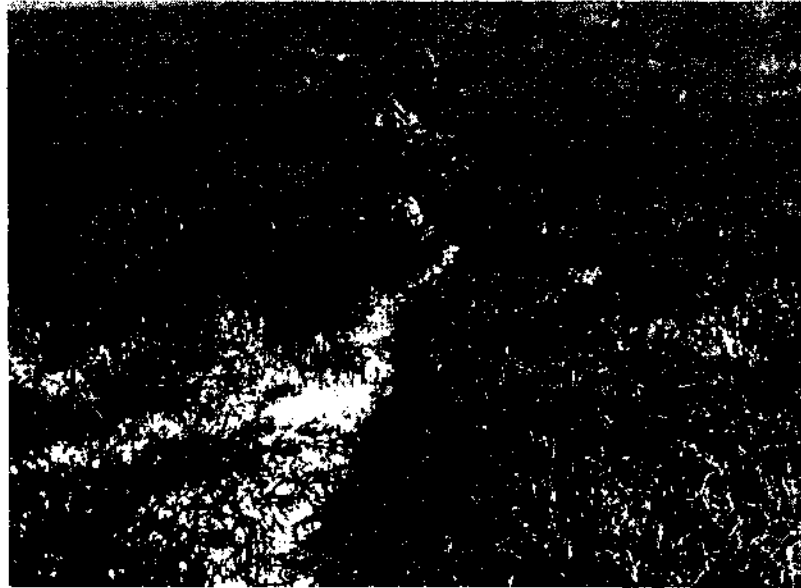

A. Looking southeast OE Pepper Island. In the foreground the fault-trace is central. It trends toward the distant +. Q. K. Gh



B. Looking north from hill west of Woodville. From trailings (Strain ranch) a large rift ridge rans northwest between 2 lanlt-sags. The western sag is followed by Pine Gulch Creek. Fault-trace raas from right of pond in foreground to left of buildings and follows gag for a mile, gradually crossing it, Q. K. G.

In the XI. S. Geological Survey map of this region the islands are not represented. In fig. 28 they are represented as they appear at half-tide, or, more strictly, the parts shown are those covered by vegetation. This figure also shows the corresponding part of the delta of Pine Gulch Creek. After crossing Pepper Island and a smaller island immediately adjacent, the fault-trace disappears under the water of the lagoon and it was next seen on the mainland of the southwest shore near the head of the lagoon. In the interval it probably crosses the delta of Pine Gulch Creek between the lines of high and low tide, but this tract was not examined until after the floods of March, 1907, which overspread it with alluvium. A disconnected group of cracks opening in the alluvial plain of the creek about 400 yards to the west (plate 39A) probably marked the position of a divergent branch of the fault. This line of disturbance crossed the creek and road near the bridge in the northern settlement of Bolinas, trending approximately north and south and fading out in both directions.

The trend of the fault-trace on Pepper Island is about N. 34° W., and if continued would bring the trace to the shore at the head of the lagoon, but its actual position on the mainland is farther west, indicating that there is either a swerving, or an offset in the part not seen. Near the shore the fault occasioned a number of landslides which obstructed the road until removed; and beyond the confusion occasioned by the landslides the trace consists of a number of subparallel cracks occupying a belt several yards in width. There is also a nearly parallel branch of the trace in a fault-sag lying a little farther west, but this could be followed only a short distance, and has since been largely obliterated by plowing. Mr. Nunes, who cultivated this sag, states that it once contained a pond or marsh, and this he had drained, but the water stood there again after the earthquake, showing that the earthquake had caused a depression of the bottom of the sag.

The diffused cracks on the main line soon gather into a narrow belt and descend into a narrow sag, containing the barn and other farm buildings of the Steele place. After following the sag for a short distance, the trace gradually rises on its eastern wall, crosses obliquely an intervening ridge, and enters a parallel sag toward the east. In this sag, which also is narrow, the trace intersects one of the roads leading from Bolinas to Woodville and immediately begins to ascend the narrow ridge bounding the sag on the east. Crossing this ridge obliquely, it skirts for 0.25 mile the western border of the much broader sag in which the water of Pine Gulch Creek gathers before it enters the canyon from which it is named. This wall it descends obliquely, and, just before reaching the bottom of the sag, intersects and offsets a line of eucalyptus trees marking a property and township boundary. The ridge phase dominates in this region (plate 37B), and near the line of eucalyptus trees the trace itself has a small offset to the west. (See fig. 18.)

Now for nearly half a mile the trace follows a valley-bottom, being divided on the way between two or three branches. The ridge phase obtains, but there are several places in flat alluvial ground where the ordinary group of cracks is replaced by a single crack with clean shear. On Mr. Strain's place two fences were crossed which afforded measurement of horizontal displacement. Beyond them the fault-trace becomes once more single, and, after passing a group of very small ridges and sags, begins to climb the eastern wall of a larger sag, which here contains Pine Gulch Creek. (See plate 41B.) Along its line there soon develop a small sag and ridge constituting a sort of shelf or notch on the wall of the deeper sag (plate 42A), and in this small sag are several ponds. (Plates 10A, 54A, and 55A.) The sag first rises for a distance and then gradually descends. The fault-trace exhibits here in alternation the ridge and trench phases, and at many points there is an apparent vertical displacement with throw of 1 or 2 feet toward the northeast. (Plates 10B and 48B.) Near Bondiotti's house the individuality of the sag is lost, and the fault-trace swerves somewhat to the east. A parallel trace develops west of it, and the two come together near Beisler's place. Northwest of Beisler's is a relatively high fault

ridge, and the fault-trace climbs the end of this, following a narrow groove or ascending sag. Here also are ponds. Farther on it passes to the east of the ridge crest and follows a side-hill sag similar to the one followed 2 miles farther south, except that it is on the eastern instead of the western face of the fault ridge. (Plates 8B and 9A.) The apparent vertical displacement is here in the opposite sense, the west side having apparently dropt, but the throw is small.

Thence the trace descends obliquely to the canyon of Olema Creek 150 feet below. Where the creek makes a decided bend toward the west the trace crosses it twice, and then follows near its west bank for several miles. Not far from the second crossing it is

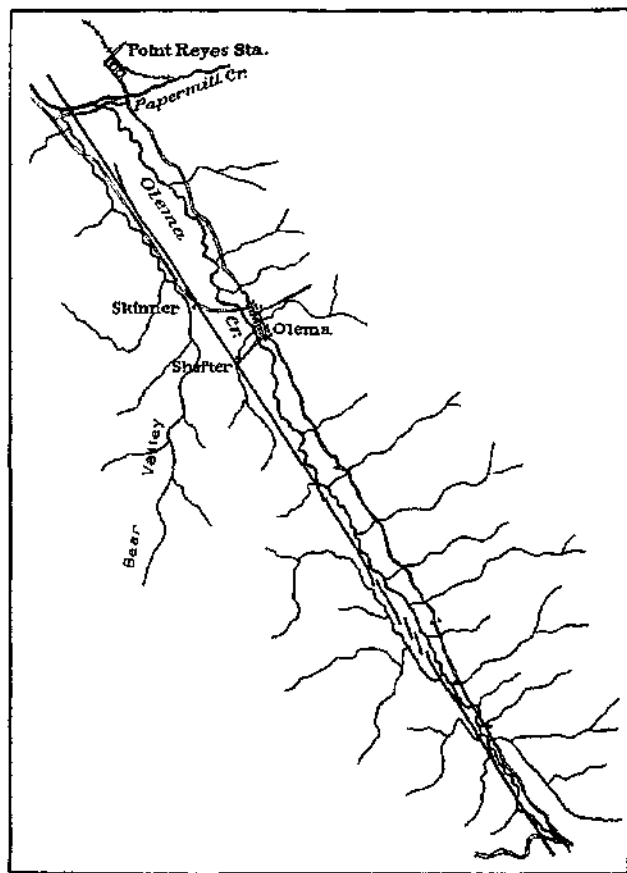

FIG. 1(i). — Map of fault-trace from Papormill Creek southward. Scale, 1:112,500.

subject to a series of offsets, giving to the trace as a whole the same echelon character commonly observed in the arrangement of its details. It is noteworthy that where these offsets occur the trace swerves somewhat toward the right and the new line begins at the left, so that the arrangement is essentially a magnification of the arrangement of cracks in what I have called the echelon phase of the fault-trace. There is this difference, however, that the elements of the larger echelon make a comparatively small angle with the general course of the trace. At several points in this part of its course the trace follows steep slopes from which the timber has not been cleared. On these slopes, which face the northeast, its course sometimes coincides with that of a very narrow sag occupied by marshy ground. Elsewhere it crosses an upland to which a series of sags gives gentle undulation and here it touches or passes near a number of ponds. (Plate 43.) The route

of the fault-trace in this region and thence north to Papermill Creek is shown by fig. 16, a compilation based on data from several sources, including a few original measurements.

A mile south of the village of Olema the trace enters a sag which is followed continuously for nearly 3 miles. At first the sag is narrow and is attached to the northeast slope of a ridge, but approaching the Shafter place the ridge crest sinks and a broad sag replaces it in the line of trend. (Plate 42B.) In following the eastern edge of this sag from the Shafter place to Papermill Creek the fault-trace also follows the western base of a line of hills. The hills are peculiar in that their western, or more strictly southwestern, base, being determined by faulting, is nearly straight (plate 42B); while their northeastern base, modified by the erosive action of Olema Creek, is scalloped. In this region the ridge; phase of the fault-trace dominates, being occasionally replaced by the trench phase. (See





A. Sag followed by fault-trace a mile north of Strain ranch, Looking southeast. Trace, concealed by bushes, runs near ponds, G.K. Q.



B. Looking southeast from point near Shafter's ranch, Okma. Fault-trace follows base of hill and includes water-filled depression. Q. K. Q.



A. Fault-trace 1.5 miles south of Olema. Looking southeast. Trace touches both ponds, being best seen between them. G. K. G.



B. Looking southeast across hill-top a mile south of Olema. Shallow sag gives hill double crest and makes a pond basin. The fault-trace, both in foreground and beyond, is divided into several branches. G. K. &



A. Fault-trace a mile northwest of Olema. Looking northwest. G. K. Q.



B. Fault-trace a mile northwest of Olema. Looking southeast. G. E. G.



A. Fault-trace on Papermill delta. Looking northwest. The water lanes are largely at right of main line of fracture. O. I. G.

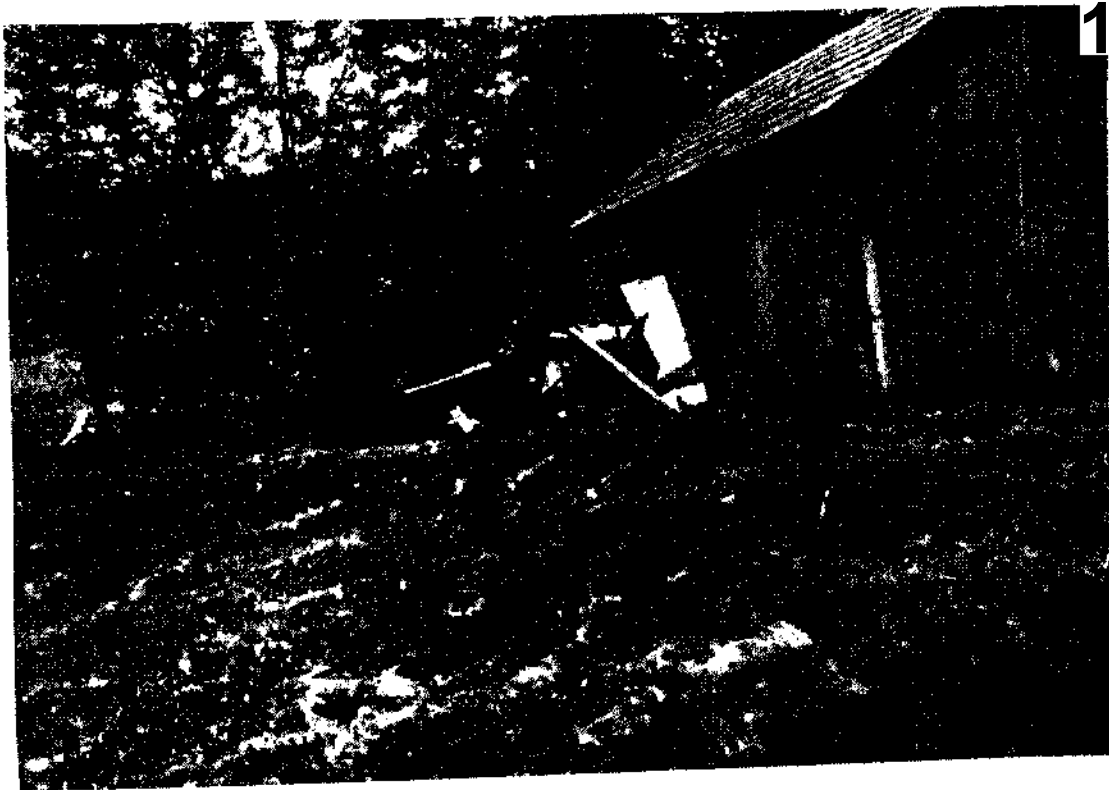

B. Branch of fault-trace in "Second Vrtflr." at Inverness. Looking south-west. G. K. G.

plate 44.) A few minor branches were seen on the east side. The pool or lane of water shown in plate 42B is about 2 feet deep. Mr. Shafter states that the ground here was dry and under cultivation before the earthquake. Shortly after the shock he noticed that the current of a creek close by was reversed.

Just south of the head of Tomales Bay, Papermill Creek enters the valley from the east, crosses to the southwest side of the valley and then turns toward the bay, in which it has built a delta. The delta occupies the whole width of the bay and is about 3 miles long, the greater part of it being submerged at high tide. At the head of the delta Olema Creek joins Papermill, bringing its tribute of detritus; and on the opposite side of the valley Papermill Creek receives the water of Bear Valley Creek, which brings no sediment but filters for some distance through a marsh. At the head of the delta a road crosses the valley, resting partly on the delta and partly on the marsh just mentioned, and furnished with an embankment to lift it above the floods. Just before reaching this road the fault-trace enters the marsh, where it quickly expands to a width of nearly 60 feet and exhibits the trench phase. Not only was the road offset by the fault and earthquake, but the portion between the walls of the trench was dropt down, the embankment sinking into the soft earth until nearly flush with the marsh. In restoring the embankment about 3.5 feet of earth were added. Close to the road Papermill Creek was crost, with offsetting of banks, and thence the fault was continued thru the delta to its end. (See plate 46A.) Its course is nearly straight and of such direction as to pass just outside the end of the cape near Millerton, the bearing being N. 35° W. At several points it is margined on the northeast by a lane of water (plate 45A), indicating that a narrow tract on that side is deprest, but no evidence was found of a general depression of land on one side of the fault as in Bolinas Lagoon. The echelon phase is dominant; the ridge phase does not appear. The trench phase obtains for short distances, and is combined for larger distances with the echelon. Where the trench phase occurs, it coincides with the zone of abundant cracks and is thus distinguished from the sag holding the lane of water.

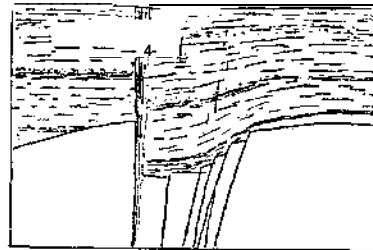

FIG. 17. Hypothetic section of fault under Papermill Delta.

The general relation of the sag to the fault-trace is shown in fig. 17. It occurs only on the northeast side, but is so persistent that, from a commanding position, the fault can be traced out by means of the water lanes. The depression will probably average more than 50 feet wide, but it eludes measurement because it fades out gradually on the side away from the fault. The greatest noted depth is 17 inches, but the average is probably less than a foot. In attempting to interpret this feature I assume that beneath the smooth plane of the delta, and buried by its soft deposits, is a variegated topography of the rift type; and the hypothesis I advance is that the new-made sag on the delta plain is the surface echo of a fault-sag of the buried topography which was made deeper by the event of April, 1906. It has already been pointed out (page 67) that the sags of the Rift which were touched by the new fault were apparently deepened; and if the true explanation of the delta-sag has been suggested, we have in that feature an indication that the deepening was not only apparent but real.

At the northern edge of the Inverness settlement is an outlying or branch fault-trace about half a mile long. (Plates 45B and 47A.) Starting in what is called the "Second Valley," it ascends to a mesa and then descends toward the "Third Valley," its course being about N. 20° W. In crossing the upland it is associated with a fault-sag and there exhibits the trench phase with horizontal displacement of 2.5 feet. Two shorter traces, trending northward, occur on the slope between the "First Mesa" and the "Second Valley."

*Measurements of throw.* — At all points where horizontal throw was observed, the ground at the southwest, as compared to ground at the northeast, moved northwestward. On Pepper Island in Bolinas Lagoon a horizontal displacement was shown by jogs in the directions of the south coast, of the limit of vegetation at the north, and of a well-defined change of flora dependent on the relation of land levels to tide. These various features are too indefinite to give value to measurement of offset, but the general indication is that the amount of throw is somewhat larger on the island than at the nearest points of measurement on the mainland.

A mile northwest of the head of Bolinas Lagoon the fault-trace intersects a row of eucalyptus trees which had been set to mark a property line, the boundary between lands of S. S. Southworth and S. McCurdy. The row is now both dislocated and curved, and as there is reason to believe it was originally alined with care, its present condition shows the distortion of the ground at the time of the earthquake. The fault-trace, as shown by the accompanying map (fig. 18), is here offset *en Echelon*, and the row of trees is not only crost by one section of the trace but approached by the other. At the point of crossing the dislocation is 10 feet. On the northwest side of the fault are six trees, all in line. On the southwest side are a dozen or more trees of which all but three are in line. If the line of either straight division be projected across the fault (broken lines in map) it passes 13.5 feet to the left of the line of the other division. The three trees nearest the

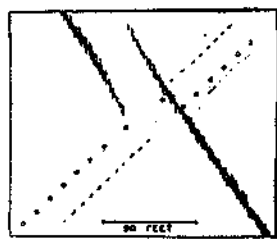

FIG. 18.—Dislocated row of eucalyptus trees.

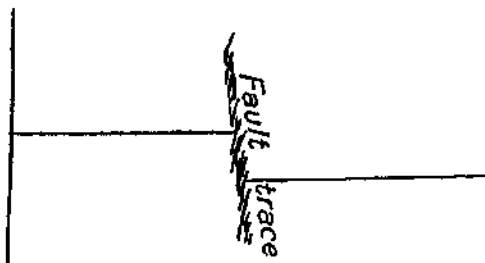

FIG. 19.—Dislocated fence on farm of S. S. Southworth, near Woodville.

fault on the southwest side follow a gently curving line. The indication is that about three-fourths of the whole displacement occurred on the main plane of the fracture, and the remainder was diffused thru the ground adjoining on the southwest. A closely related condition exists at the southern limit of the same field, where the fault-trace intersects a fence at right angles. The offset is 7 feet 8 inches, and this is accompanied by a change of direction. (Fig. 19.) Unfortunately the fence is too short to indicate in full the changes of the ground, but the suggestion is that in addition to the visible offset, there is a diffused shear affecting the ground southwest of the fault so that the entire displacement is greater than the amount shown by the offset. Assuming the fence to have been originally straight, the total displacement here was more than 12 feet.

On Mr. E. R. Strain's place, west of Woodville, measurements are afforded by the disturbance of two fences. The more southerly (fig. 20) is crost by two visible branches of the fault, and there is probably more or less diffused shear in the intervening ground. The fence, said by Mr. Strain to have been originally straight, has now two straight portions, *AB* and *CD*, and the distance from *AB* to *E*, on the line of *CD* produced, is 15 feet. The second fence, standing a little farther north, is intersected by one visible fault-trace, the continuation of the trace which crosses the first fence near *B*. On this line the fence is broken and offset 8.5 feet. The remnant of fence to the southwest is straight, but swerves in approaching the fault-trace, as indicated in fig. 21 and in plate 49A. The total displacement of the straight portions of the fence is about 11 feet.

The four localities last mentioned are included in the space of 0.5 mile. Their several indications of the total displacement, in the order of position from south to north, are 12 +, 13.5, 15, and 11 feet. The range of these determinations is 4 feet and their approximate mean 13 feet. At each locality the indicated displacement consists partly of definite faulting along one or two planes of fracture, and partly of diffused shear, distributed thru a belt of rock, or at least a belt of soil. At each locality the indicated shear is all in one direction. At each locality the measurement depends for its authority on the assumption that the disturbed fence or row of trees was originally straight.

Eight miles farther north, at Mr. W. D. Skinner's place, near Olema, the entire fault is apparently concentrated in a single narrow zone, and the several measurements made are in close accord. The fence south of his barn (fig. 22) was offset 15.5 feet. The barn, beneath which the fault-trace past, remained attached to the foundation on the southwest side, but was broken from it on the northwest side and dragged 16 feet. A path in the garden, originally opposite steps leading to the porch, was offset 15 feet. (Plate 38D.) A row of raspberry bushes in the garden was offset 14.5 feet. The mean of these four measurements is 15.25 feet, and their range is 1.5 feet.

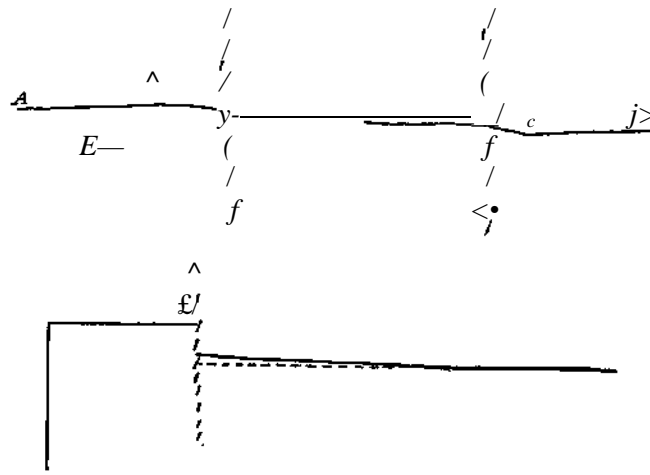

FIGS. 20 and 21. Dislocation of fence near Olema, Calif. Strain, near

The road running southwest from Point Reyes Station and crossing the valley at the head of Papermill Creek delta was offset 20 feet. (Fig. 23 and plate 47B.) AS the fault-trace at this point was between 50 and 60 feet wide, and as the embankment of the road for that distance was broken into several pieces, it was not possible to make certain that the dis severed remnants of the road had originally been in exact alinement. It is probable, however, that the road was approximately straight before the earthquake, and that the exceptionally great offset at this point is to be explained as the result of a horizontal shifting of the surface materials. The embankment of the road rested on marshy ground so soft that a portion of the embankment sank into it, and material of this character was in other localities demonstrably shifted.

A number of other measurements of displacement were made, but these, for various reasons, do not seem worthy of record, altho some of them were noted in an earlier report. Several were connected with the dislocation of trails, but in every such instance the trail made only a small angle with the strike of the fault and part of it was broken up along with the fractured turf. The endeavor to find more favorable angles of intersection drew attention to the fact that because the dominant trend of hills and valleys in the Rift is northwest-southeast, the lines of easy travel, minor as well as main, are largely parallel to the fault-trace. Other measurements were connected with the offset of fences, and, altho definite in themselves, have little value because there is reason to believe they represent only a part of the local displacement. The part represented by them is in every case less than 10 feet. It is noteworthy in this connection that most farm fences which were intersected by the fault-trace either terminated within a few yards of it or changed direction at about that place. Like the trails, they were adjusted to topographic peculiarities created by earlier faulting along the same line.

The phenomena of vertical displacement are in general so irregular as to indicate that they were determined chiefly by surface conditions. Where the ground sloped toward

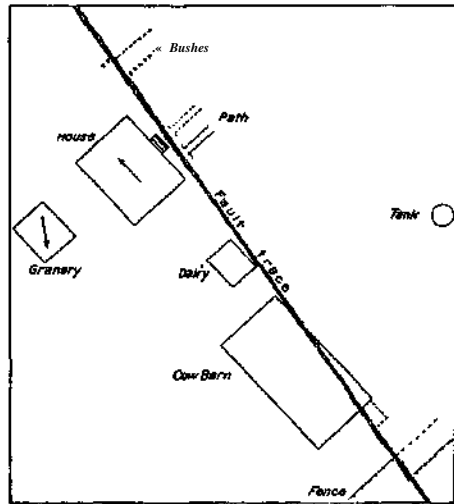

FIG. 22.—Plan of Skinner premises, showing character of displacements measured. The broken lines show positions of hushes, path, and fence before earthquake in relation to objects west of fault; also position before earthquake of corner of barn with reference to ground east of fault.

the northwest the horizontal throw caused an apparent vertical downthrow to the northeast. (Plate 48A.) Where the ground sloped toward the southeast an apparent vertical throw to the southwest was produced. Where the fault-trace followed a narrow sag interrupting the side slope of a ridge, the apparent vertical throw was on the side toward the ridge, as indicated in the diagram, fig. 6. (See also plates 10B and 48B.) The only unqualified record of vertical displacement is on Pepper Island in Bolinas Lagoon, where the mean of seven measurements shows a downthrow of 12 inches on the northeast side. The question whether the faulting along the plane of rupture was accompanied by the elevation or depression of large areas will be discust in another place.

*Movement normal to the fault-plane.* — Where the fault-trace is a trench, imperfectly filled by fragments of soil and rock, it is clear that the walls of the fault stand farther apart than before the earthquake. Where the fault-trace has the echelon phase and consists of a system of cracks, not accompanied by visible elevation of the surface, it is also evident that the walls stand farther apart. Where the fault-trace is a ridge, composed of fragments of soil, with more or less interstitial void, it may be assumed that the voids are at least equivalent to the ridge in volume. As the fault-trace is made up almost wholly of these three phases, it follows that in the visible part of the fault its walls did not approach as a result of the faulting but receded a little.

In this connection mention may be made of the fact that at the Shafter ranch a fault crevice was momentarily so wide as to admit a cow, which fell in head first and was thus entombed. The closure which immediately followed left only the tail visible. At this point the fault-trace was a trench 8 or 8 feet wide, and the general level of the soil blocks within it was 1 or 2 feet below that of the adjacent undisturbed ground.

One suggestion in connection with the recession of the fault walls near the surface of the ground is that temporary stresses incidental to the faulting caused permanent compression of the adjacent terranes. It is a fact familiar to engineers that most superficial formations, while in their natural, undisturbed condition, have a structure involving voids, and that they may be compress by overpowering this structure. But, if I understand the matter, such formations are not compressible (except elastically) when their voids are full of water, so that accommodation for dilatation of the fault-zone could have been made in this way only so far as the ground was dry. As the ground was full of water in many places — including,

the northwest the horizontal throw caused an apparent vertical downthrow to the northeast. (Plate 48A.) Where the ground sloped toward the southeast an apparent vertical throw to the southwest was produced. Where the fault-trace followed a narrow sag interrupting the side slope of a ridge, the apparent vertical throw was on the side toward the ridge, as indicated in the diagram, fig. 6. (See also plates 10B and 48B.) The only unqualified record of vertical displacement is on Pepper Island in Bolinas Lagoon, where the mean of seven measurements shows a downthrow of 12 inches on the northeast side. The question whether the faulting along the plane of rupture was accompanied by the elevation or depression of large areas will be discust in another place.

*Movement normal to the fault-plane.* — Where the fault-trace is a trench, imperfectly filled by fragments of soil and rock, it is clear that the walls of the fault stand farther apart than before the earthquake. Where the fault-trace has the echelon phase and consists of a system of cracks,

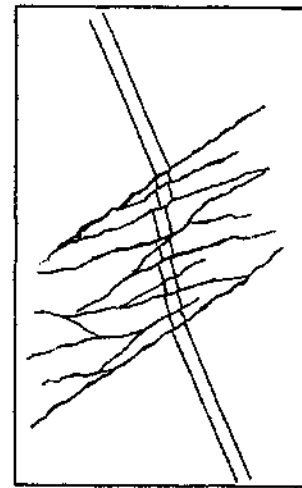
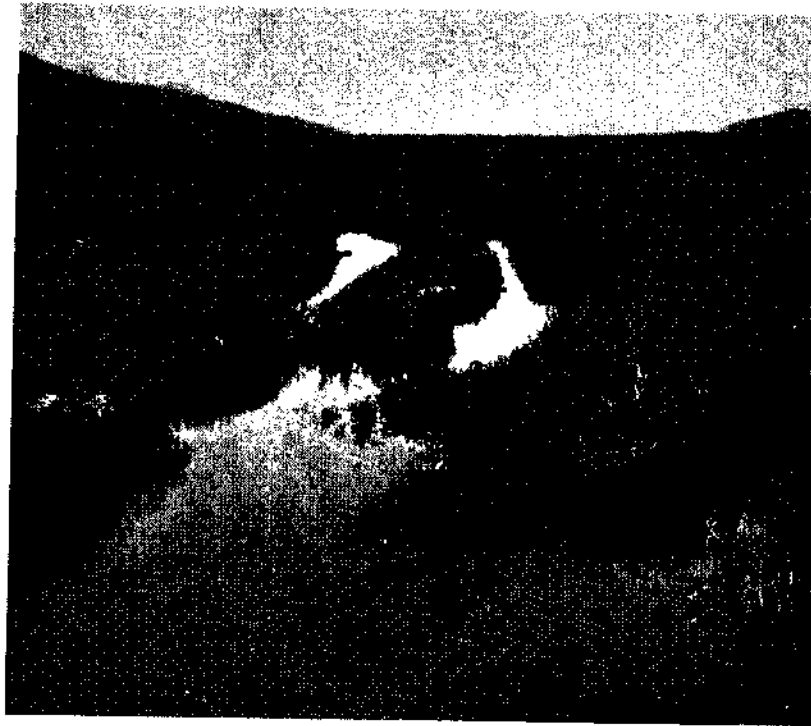

FIG. 23.—Dislocated road shown in plate 47B. Parallel lines represent wheel tracks. Ramifying lines indicate cracks of fault-zone.





A. Fault-trace on Papermill delta. Looking northwest, ff. K. G.



B. Fault-trace at the Skinner place, near Olesna. Illustrating trench ph<sub>aw</sub>. O. X. &



A. Branch of fault-trace on "north mesa" at Inverness, Looking southeast. Q. K. Q.

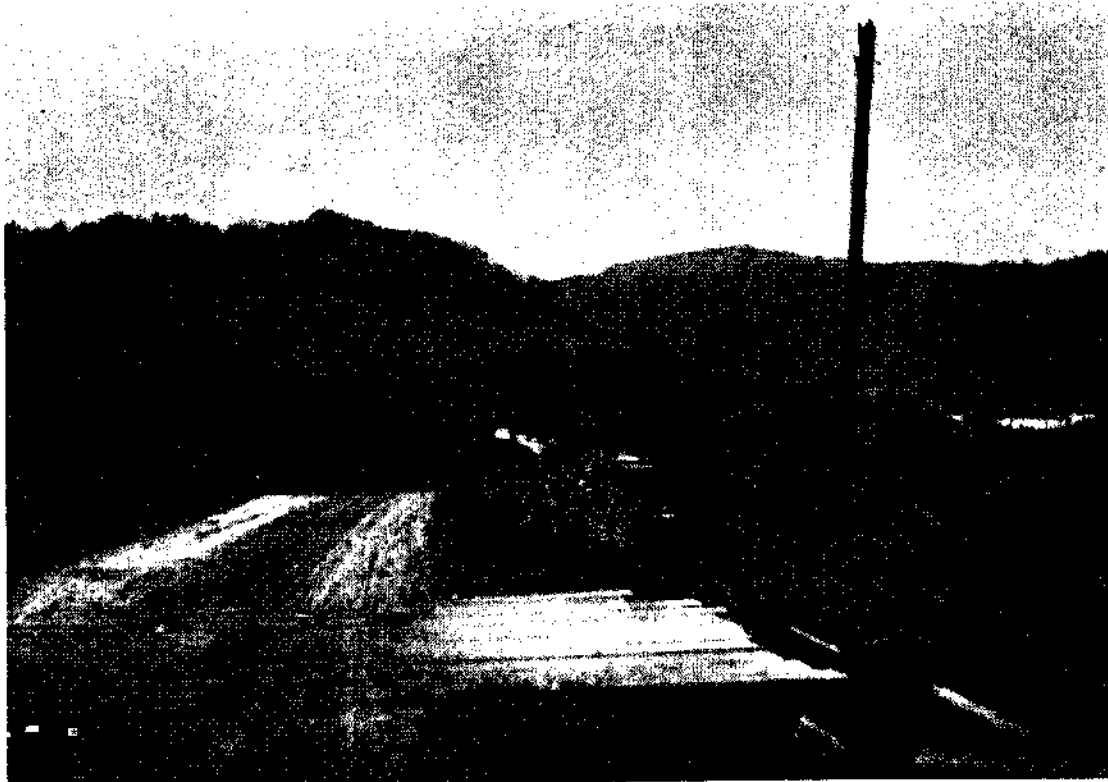

B. road offset by fault. Looking toward Mt. G. K. Q.



A. Fault-trace a mile northwest of Olema. Looking south, Appearance of vertical displacement largely due to combination of horizontal displacement with slope of ground. G. T. L. Q.

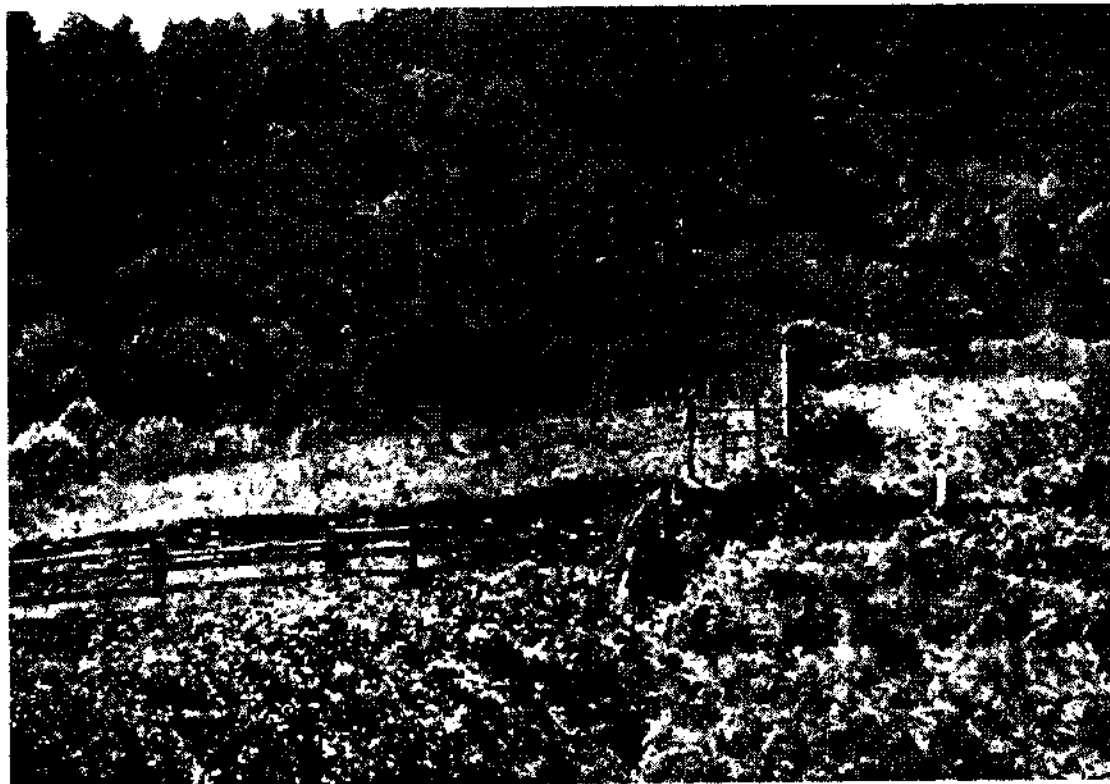

B. Fault-trace of Bear River. Looking south. Shows vertical displacement at a sag. Horizontal displacement shows a fence, which had been displaced. G. T. L. Q.

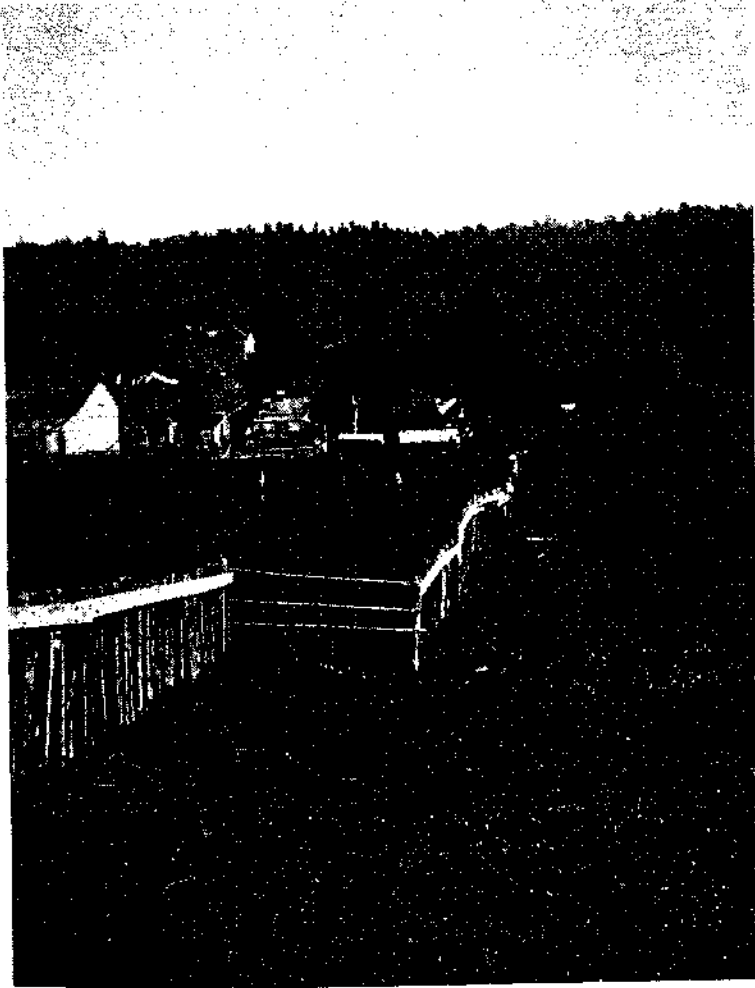

A. Fence offset by fault. Looking northwest. Camera was alined with straight part offence beyond the disturbance, to bring out flexure as well as offset of fence. Q. K. G.

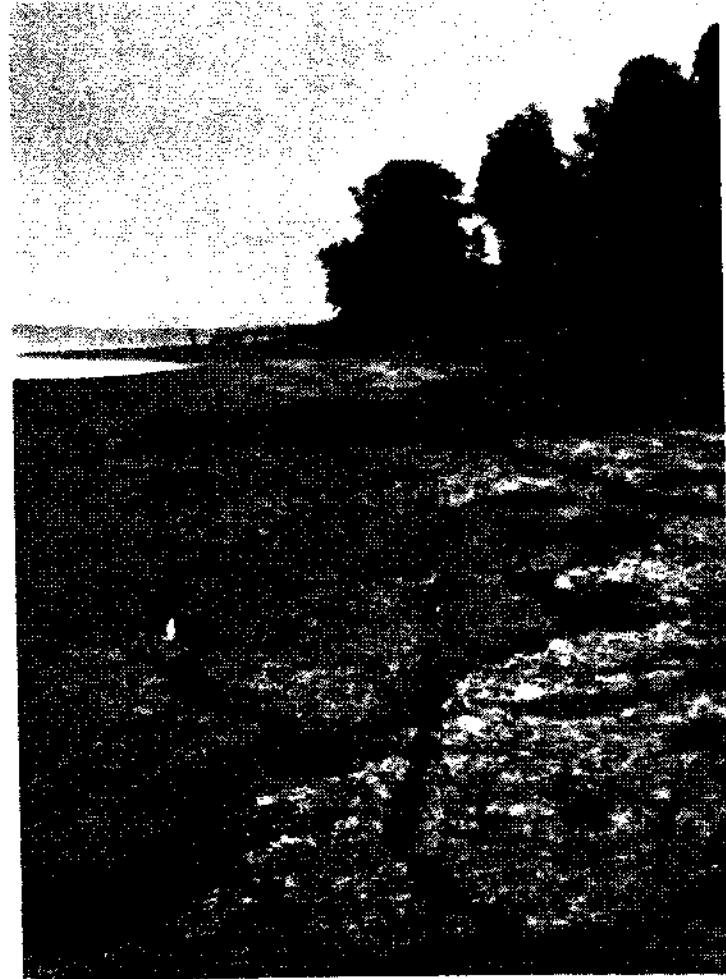

B. Cracks made by earthquake in tidal mud near head of Bolinas Lagoon. O.K.G.

for example, the locality of the cow incident, the Papermill delta, and Pepper Island — the suggestion of lateral compression seems of little avail.

Another suggestion is that the surface phenomena are essentially representative of what occurred at greater depths — that is, that in depth, as well as superficially, the faulting left the fault walls farther apart than they were before. Fissure veins show that voids have often resulted from subterranean faulting. Unless the surface along which the movement occurred is mathematically plane — or conforms to some equally difficult geometric condition — the two fault walls should not accurately fit together after the movement, but should tend to maintain contact thru only a part of their extent. If thru a part of their extent they are separated, the walls are on the average farther apart than before.

There would necessarily be some adjustment thru changes within the rock masses on the two sides of the fault. Compressive strains would be locally increased and reduced, and there would be subordinate movements among the minor earth blocks of the great shear zone whose surface features appear in the Rift. We have evidence of such adjustments, in fact, in branches of the fault-trace and in a system of bedrock cracks presently to be described; as well as in the subsidence of the bottoms of sags in the immediate vicinity of the fault. Interpreting other sag phenomena in the light of the long sag of the Papermill Creek delta, the fault of 1906 appears to have permitted a very considerable volume of material to sink into its fissure.

The general tendency of this discussion falls in line with a generalization as to the Rift, which in the Bolinas-Tomales region appears to show distinctly more local subsidence than local elevation.

*Earlier fault-traces.* — Because the future is to be judged by the past, there is much interest in the question of the frequency and recency of fault movements along the Rift previous to 1906. In my later studies of the Rift belt, I have had in mind the possibility of discovering fault-traces similar to that of 1906 but less fresh in appearance. In the little bluffs at the edges of sags, and in the ponds and marshes, there is abundant evidence of early faulting, but it is essentially geologic and does not necessarily pertain to occurrences of the past century or two. The fault-trace, however, is a relatively perishable and transient phenomenon, and its preservation might have comparatively definite meaning.

At two localities I thought I discovered old "traces" of the ridge type. In each case the features occur on a hill slope where the trace made in 1906 appears in several divisions or branches; and what I took to be old traces are distinguished chiefly by the absence of cracks. The localities are close together, about 0.5 mile south of the Shafter ranch, and may be identified by means of plate 43B. The features occur on the slope at the left, but are too indefinite to be recognized in the view. If these old traces have been properly identified, they are of very moderate antiquity. I should suppose that the ridges of the recent trace would lapse to such a condition in four or five years and that they might persist, under pasture conditions, for two or three decades. The history of the recent trace shows that a single plowing means effacement, but the general appearance of the field in which the old traces occur indicates that it was never plowed.

*Cracks.* — In preliminary reports I have classified the earthquake cracks as primary and secondary, the primary being occasioned by strains which existed before the earthquake, and the secondary being caused by the earthquake. With the multiplication of observations this classification has become increasingly difficult, and I now find it more convenient to group the cracks as superficial and deep, or superficial and bedrock.

Many of the superficial cracks are in alluvium. In the field excursions of April and May, 1906, they were seen in all alluvial formations within the Rift belt and for some distance on each side. The greater number appeared to be merely partings without

vertical or horizontal throw. In general they were not parallel with one another nor were they otherwise systematically arranged, except that some of them were apt to occur along the boundary between alluvium and a firmer formation. They were rambling rather than straight and were often branched. They ranged in width from a fraction of an inch to several inches. They were seen from the train in the bottom-land of Papermill Creek within a mile of Point Reyes Station. They were also seen in the delta of Papermill Creek, in the bottom-land of Olema Creek near Olema, and in the delta of Pine Gulch Creek. They were seen in the bottom-lands and deltas of a number of small creeks entering Tomales Bay from the west between Inverness and the head of the bay. Other localities were tidal marshes at the head of Bolinas Lagoon (plate 49B), at the head of Tomales Bay, and in small estuaries near Inverness. They were seen in the marsh of Bear Valley Creek near where the stream joins Papermill Creek; and a road embankment crossing that marsh was elaborately cracked and faulted thru much of its extent.

It is noteworthy that the neighboring road crossing a marshy portion of the Papermill delta was much less cracked, and the difference is probably to be ascribed to the difference in height and strength of the two embankments. The thinner one suffered the more.

The localities enumerated are merely those which came under observation. Within the zone of high intensity no marshes and no bottom lands were seen which did not exhibit cracks, and I regard their cracking as a general phenomenon. The elaborate cracking of a roadway across one of the marshes seems specially significant. In the adjacent soft marsh close attention was necessary to discover cracks. To a large extent they were concealed by the vegetation, and it is probable also that many which were opened during the earthquake agitation immediately closed again and were practically obliterated by the welding of the mud. But the road embankment, being free from vegetation and composed of comparatively rigid and brittle material, retained all the cracks made during the agitation, and thus served to record the thoro shattering of an unconsolidated formation when subjected to strong vibration. (Plate 50.)

Another class of superficial cracks affected hillsides, penetrating only the coating of loose material — decomposed rock and talus. The conspicuous individuals of this type are those that follow contours. Along these there was often a notable width of crack, accompanied by a settling on the down-hill side, and many cracks of this type are still visible. They are in effect the heads of incipient landslides and might with equal propriety be described under another caption. They are numerous thruout the Rift belt and fairly abundant on steep hillsides for more than a mile to the west. East of the Rift they are inconspicuous and believed to be rare. Some of the best examples are on the northeastern slope of Mount Whittenberg, about a mile from the fault-trace, the locality being favorable for observation because of the absence of forest.

Superficial cracks of a third type are connected with side-hill roads. (See plate 51.) In such roads there is usually a notch cut in the hillside and the excavated material is thrown outward so as to make an embankment. The roadbed thus consists in part of the natural formation and in part of an artificial and relatively loose embankment. In the loose material, and frequently along the line separating it from the firmer ground, cracks were extensively developed, often accompanied by evident settling of the outer bank. Their magnitude depended in part on the character of the material, but in large part also on the intensity of the earthquake. Where they were of such magnitude as to injure the roadway they were soon obliterated by road repairers, and elsewhere they tended to disappear in consequence of the traffic; but while they lasted they constituted an excellent gage of intensity, and much use was made of them in districts where there were few buildings\*

Bedrock cracks occurred at many points within the Rift, usually appearing as branches from the faults. They were seen also at a number of points west of the Rift, their distribution reaching to the ocean in the vicinity of Point Reyes, ten miles from the fault-trace. At the more remote points they were quite small, often barely discernible, and no system of arrangement was discovered. They are peculiarly prominent along the summit of the ridge constituting the southwestern rim of the main Bolinas-Tomales trough. This summit was visited on four lines of road, and at each locality conspicuous cracks were found. On the road from Inverness to Point Reyes Post Office, about a mile in a direct line from Tomales Bay, a crack was traced for more than 800 feet. Its general trend is east and west, but its course is not straight and it has a branch diverging at  $45^\circ$ . Along this crack there is a horizontal throw of from 2 to 6 inches, the south side having moved westward with reference to the north side.

On the next road to the southward a group of cracks was seen at a point a mile from the shore of Tomales Bay. These cracks occur on a crest trending northwest and southeast, and their trend makes a small angle with that of the crest. The arrangement of the cracks suggests horizontal shear, but no definite observation was made on this point. They extend for several hundred feet at least, but were not traced out.

On Mount Whittenberg there are two bedrock cracks. One of these crosses the northeastern spur of the peak near its junction with the main crest. Its trend is approximately northwest and southeast and at one point it margins a fault-sag. As it assumes in one place the ridge phase of the fault-crop, I infer that it has horizontal displacement. On the opposite side of the main crest is a crack which was traced for about 1,000 feet. Its general course is northwest-southeast, but it is not straight and exhibits a vertical throw of 1 or 2 feet to the southwest. At one point it touches a fault-sag. Between these two long cracks a group of short cracks occurred, with similar trend, on a knob constituting a portion of the main divide.

About 6 miles farther south, at the head of Pine Gulch Creek, another road crosses the range, and in following this a group of cracks was seen. A short distance west of the divide, and about a mile in a direct line from the fault-trace, is a fault-sag trending northwest-southeast. On each side of it a crack was seen, the eastern crack being the wider and showing a small throw to the southwest. This crack was traced for about 0.75 mile and found to curve thru an arc of nearly  $90^\circ$  from southeast to southwest. At its southwest end, or at least the southwestern limit of tracing, it is on a ridge, and it there expands into, or else is replaced by, a group of cracks diverging fan-wise. On each member of the group faulting took place, the downthrow being toward the northwest except in the case of two apparently short cracks with downthrow to the southeast. On four of these cracks the throw was greater than 1 foot, and at one place it was about 5 feet. Each crack was associated with a preëxistent bluff or scarp, indicating that earlier movements have occurred at the same place. The field in which the principal phenomena occur is cultivated with the exception of the steeper scarps, whose faces retain a bushy growth. (See plates 52A and 53A.)

A tract lying between this locality and the coast, and extending several miles in each direction, exhibits a peculiar topography intermediate in type between that of the Rift and that commonly associated with landslides. Near the coast are a number of basins with ponds or lakes of much larger size than those along the Rift, and in association with these are seen a number of sags similar to the fault sags of the Rift. On several lines which were thought from the physiography to represent partings between dislocated blocks, earthquake cracks were seen, and on one of these near the coast there was a vertical displacement of 3 feet, the downthrow being to the southwest.

All thru the Rift there is association of earthquake cracks with fault-sap; probably half of the sap were bordered by such cracks on one side or the other, the crack usually

following the line of separation between the side slope and bottom slope. In some instances there was a crack on each side of the sag, but more frequently on one side only. Where the sag contained a pond the crack was usually present. With little or no exception these cracks exhibit downthrow on the side toward the sag. (See plate 52B.) At least two explanations of these cracks are possible. As the bottom of the sag usually shows no outcrop of rock and appears to consist wholly of soil washed down from the sides, it is possible that the earthquake caused a settling of the alluvium toward the middle of the sag and that the marginal crack is due to this settling. On the other hand, it is possible that a bedrock wedge underlying the sag was permitted to settle during the earthquake and that such settling caused the marginal crack. In the first case the cracks would belong to the superficial class; in the second, to the bedrock class. While the data at hand are not decisive, I am of opinion (as already stated) that the cracks resulted from some sort of readjustment of the small earth blocks whose upper surfaces determine the Rift topography.

*Springs.* — The general testimony of residents is that the flow of springs was modified all thru the peninsula west of the Rift. As it was practically impossible to get quantitative data, I made few records of specific instances, but every farm owner or farm tenant of that region with whom I talked told me of some spring whose flow had been increased, diminished, or stopt at the time of the earthquake, the change being either temporary or permanent. Several lakes of the group near the coast (known as Seven Lakes) experienced changes, the greater number having their levels lowered. A pond known as Mud Lake, on the divide at the head of Pine Gulch Creek and about a mile from the fault-trace, suddenly and permanently lost its water at the time of the earthquake. At the same time a small spring on the east side of the ridge and about 0.75 mile in a direct line from the pond, was suddenly enlarged, a torrent of water gushing from it for several hours and then gradually diminishing. It is suggested with much plausibility by residents that these two phenomena were connected, the earthquake opening a subterranean course thru which the water of the pond was conveyed to the hillside spring. I heard of no changes in springs east of the fault-trace, altho a number of inquiries were made.

*Interpretation of bedrock cracks and springs.* — The changes in springs are of course the results of changes in the conditions of underground circulation, and in a general way may be ascribed to the influence of newly-formed cracks. The spring phenomena and the visible cracks may be grouped together as indications of bedrock fracturing, and their distribution indicates the regions in which the rocky foundation of the land was more or less shattered. That region includes the Rift and extends from it to the ocean. The phenomena diminish somewhat with distance from the Rift, but the fracturing appears to have been important and general thru a belt 4 or 5 miles broad.

*Landslide®.* — The earthquake started a number of landslides. A few of these were on the line of the fault, especially where its trace intersected a cliff facing Bolinas Lagoon. Others were from cliffs of earth or weak rock bordering the ocean, one of the bays, or a creek. None were seen of unusual type or of great importance, except from the obstructions to roads which they occasioned. South of Willow Camp a road overlooking the sea had been cut in the face of previous landslides, and the renewed movement put it out of commission. In the same manner roadways were obstructed at the entrance to Bolinas Lagoon, at two points near the head of the lagoon on the west side, and on the coast of Tomales Bay at Inverness.

There were many landslides of the dry type on hillsides, masses of earth and rock breaking away on steep slopes and tumbling to the bottom. The largest seen were on the high ridge west of Tomales Hay, in the vicinity of Sunshine Ranch. Closely related to these were small falls of earth and rock from the low cliffs created in the construction of Mde-hill roads. (Plate 53B.) They occurred at a few places within the Rift and



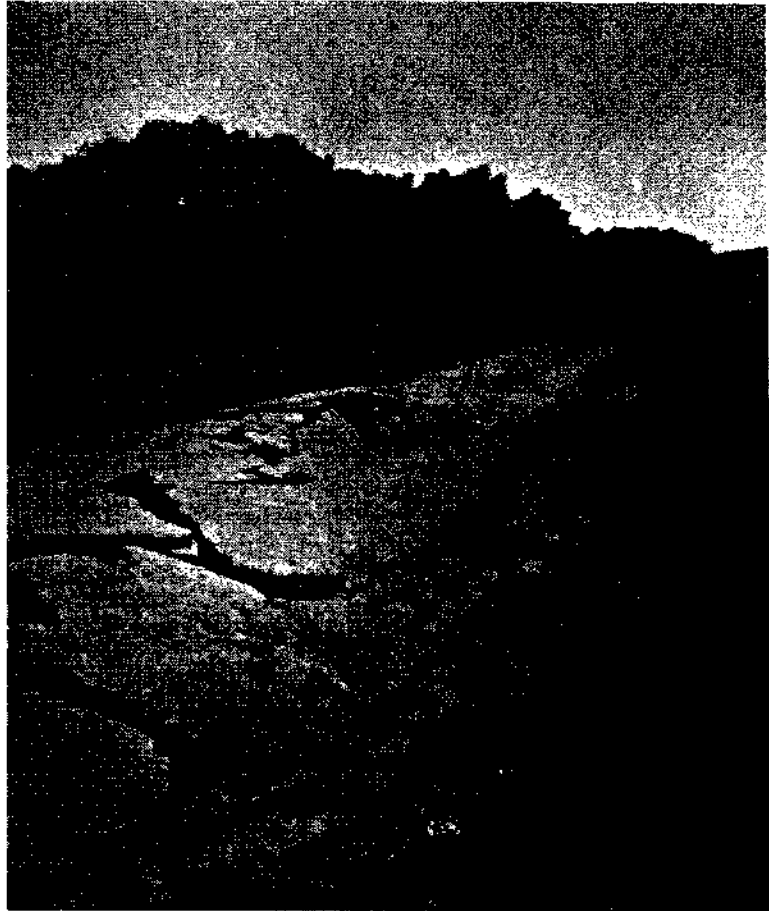

A. Road embankment broken by shaking of soft ground beneath. Southwest of Point Beyes Station and 10 rods from fault-trace. Q. K. Q.



B. Faults in road embankment, southwest of Point Beyes Station. Fault-trace is beyond fence. Ground lurched toward marsh of Bear Valley Creek. Q. K. G.



A. Roadside crack 2 miles west of fault, between Inverness and Point Reyes P. O. G. K. G.



B. Roadside crack a mile southeast of Inverness. G. K. G.



A. Group of earthquake cracks southwest of head of Pine Onion Creek. Looking southwest. Structure well indicated by sky line. Since dislocation field has been plowed and farm road graded up fault-scarpi. Compare Plate 53 A. G. I. &



B. Earthquake cracks in BolinM at tip of aa M4rtfefwi» ••{. Q- K. Q.

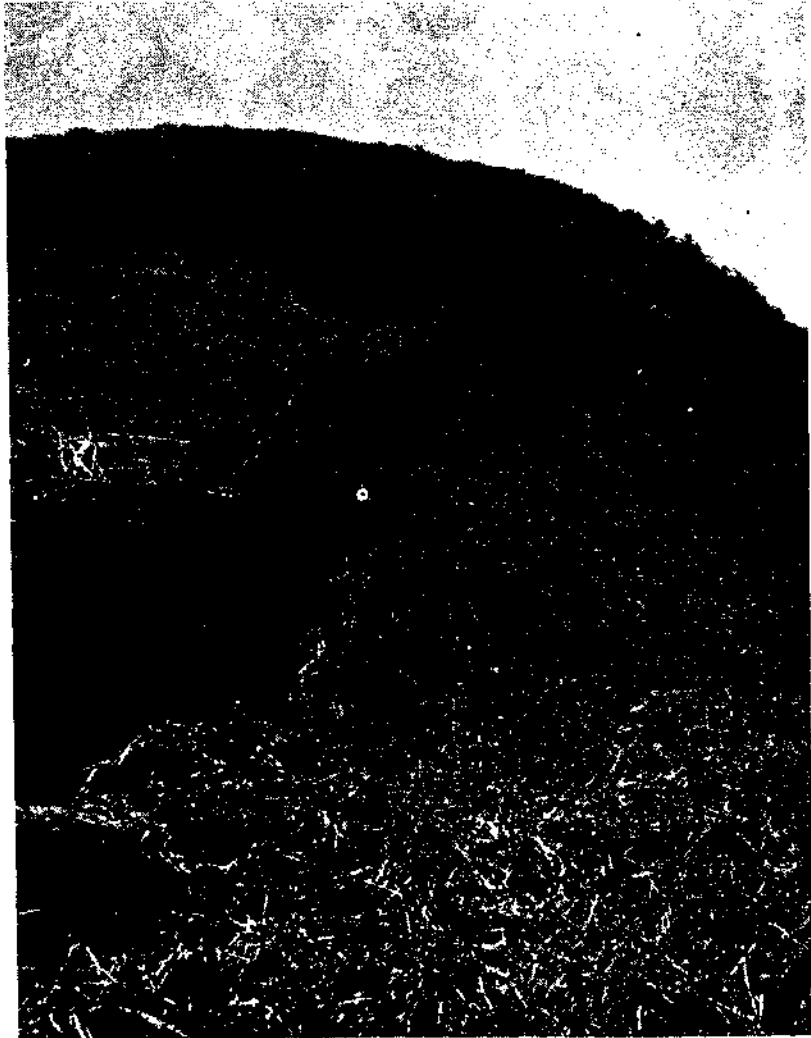

A. Fault-scarp on earthquake crack. Throw is about 5 feet. Compare Plate 52 A. (J. T. J.)



B. Landslide from road-cliff about two miles west of Inverness. Slide occurred at time of earthquake. (G. K. &)

east of it, but mostly in the district to the west, where all of the country roads were more or less obstructed.

On the west side of the main ridge west of the head of Tomales Bay there occurred two wet slides. In one case a hillside bog was loosened from the slope on which it rested and descended as a flow of mud to a canyon bottom 100 or 200 feet below. In the other case the earth beneath a wet meadow in a rather steep canyon flowed down the canyon for about 0.5 mile, overpowering trees on its way and leaving a deposit 15 or 20 feet deep in places. This was the largest individual slide observed.

In all the cases mentioned the conditions were such that slides would have taken place at some time had the earthquake not occurred. But this statement may not properly apply to the cases about to be mentioned.

On the steep southern face of Mount Tamalpais a number of rocks were loosened and rolled down the slope, some of them being large enough to cut swaths thru the thicket which were visible for months afterward. Similar swaths were seen under a crag in the vicinity of Willow Camp. In the bottom-lands of creeks it happened at many places that a slice of the alluvium was separated by a crack parallel to the bank and slid into or toward the stream. In some cases alluvium lying with a gentle slope adjacent to a marsh slid toward the marsh, opening a crack along its upper edge.

Mention has already been made of numerous hillside cracks which marked incipient landslides. In such cases the downward motion apparently began during the earthquake agitation, but the momentum acquired was not sufficient to continue the motion after the earthquake stopt. In a very large number of these localities motion was resumed and landslides occurred during a period of excessive rainfall in the spring of 1907. (Plates 54A and 55A.) SO far as my observation goes, all of the landslides having this history were wet, the material usually flowing freely down the slope as a thin mud. The probable explanation is that the cracks made in April, 1906, served to admit the water flowing over the surface during the rains of 1907, so that the material which was too dry to flow in 1906 acquired the proper consistency and continued its course the following year. The number of landslides which the earthquake induced in this indirect way is possibly as large as the number which were an immediate consequence of the shock.

The phenomena of landslides bring to attention certain conditions of flow which affect a variety of earthquake features. Consolidated formations hold steep slopes by virtue of cohesion. Incoherent formations maintain the "slope of repose" —  $30^{\circ}$  to  $35^{\circ}$  — by virtue of the resistance to sliding, or the static friction, of their particles. Certain formations, including some clays and clay mixtures, become coherent by drying and incoherent by wetting. Incoherent formations, as a rule, have a less coefficient of friction when wet than when dry. For these reasons the addition of water is the ordinary immediate cause of a landslide; it overcomes cohesion, or else it reduces the frictional resistance, and slipping or flowing is the result. During a strong earthquake, agitation overcomes the cohesion of feebly-coherent formations and suspends the operation of static friction between the particles of incoherent formations, thus affecting the materials somewhat as water affects them. In the case of landslides, it may enable an incoherent dry formation to flow as if wet; and it may temporarily give to an incoherent formation, wet or dry, a condition of quasi-liquidity.

*Ridging and shifting of tide lands.* — The general width of Tomales Bay near its head is about a mile, tho it is constricted at one point by a promontory jutting out from the east shore. (Fig. 24.) Papermill Creek, entering at its head, has built a delta which slopes so gently toward the deeper water that the tides range over it for a distance of about 3 miles. The upper half of the slope is covered by vegetation of various kinds and the lower half is of bare mud. In the region of vegetation the soil has sand as well as mud, and the bed of the stream is of sand and gravel. As the delta deposit has been

built up in connection with a shifting of the stream channel, or channels, it is probably composed of an irregular alternation of mud, sand, and gravel. The fault-trace, as already described, passes thru the midst of the tide lands, following the axis of the depression which contains the bay. Continuous with the mud of the lower slope of the delta is a mud shoal following the western shore of the bay past Inverness. This shoal and other parts of the tide lands were seen soon after the earthquake from the road which follows the west shore of the bay to Inverness, and a few photographs were made. Other photographs were made at various dates afterwards, and the tide lands were explored on foot on April 18, 1907.

A large portion of the delta was thrown by the earthquake into gentle undulations, the difference in height between the swells and hollows being usually less than a foot.

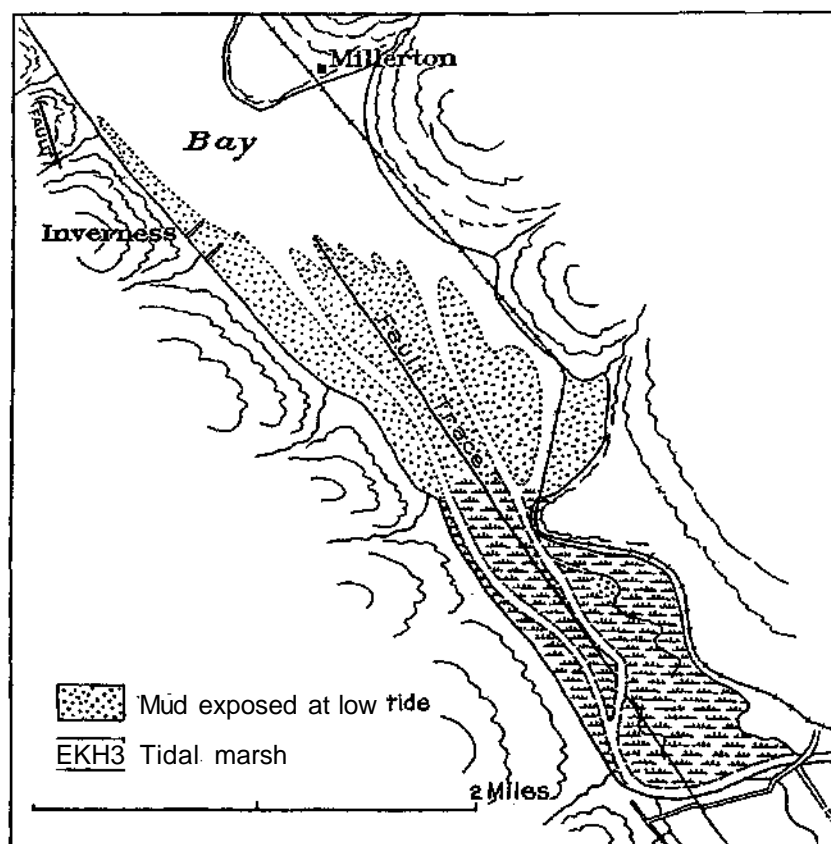

FIG. 24. —Map of Papermill Delta at head of Tomales Bay.

The chief evidence of this is found in the distribution of pools at low tide, and where vegetation is present the evidence from pools is supplemented by that from the condition of the plants. The undulations were not elongate and were not found to have a systematic relation to the fault.

When the tidal mud was first seen after the earthquake, it was observed to be covered with ridges and troughs. (Plate 54B.) This corrugation was gradually smoothed out by the action of the waves (plates 55B and 56A), SO that at the expiration of a year its expression was largely lost, tho a few of the larger ritiges could still be traced, and much of the plain retained a pattern imprest on it by the ridging. It is probable that the entire tract of tidal mud was thus affected, altho the ridges were not seen on the area lying nearest to the east shore. That area did not come under observation until after the spring floods



A. Landslip 4 miles northwest of Bolinas Lagoon. Looking south-southwest. Slide caused by rains early in 1907, indirectly by earthquake of 1906. <sup>each</sup> <sub>G t A p o n a r i f t p 0 A</sub>, caused directly



B. Bidgod and plain 1 mile from <sup>sm isremmB</sup>. Looking south-southwest. Jfr. Haass'lon's bar at right. April 38, 2906. Tide us low, Pools occupy the depressions, O. L. G.



A. Landslides 2.5 miles northwest of Bolkas Lagoon. Looking northeast. Storm waters of 1907, guided by earthquake cracks, converted earth into soft mud. G. K. G.



B. South part of Inverness shoal, at low tide, April 23, 1906. Looking north-northwest. Lane of water separates firm, gravelly beach from mud shifted shoreward by earthquake. G. K. G.





A. Edges caused by earthquake on tidal flat of Tomales Bay, 1 mile south of Inverness. Looking north. December, 1906, & K. Q.

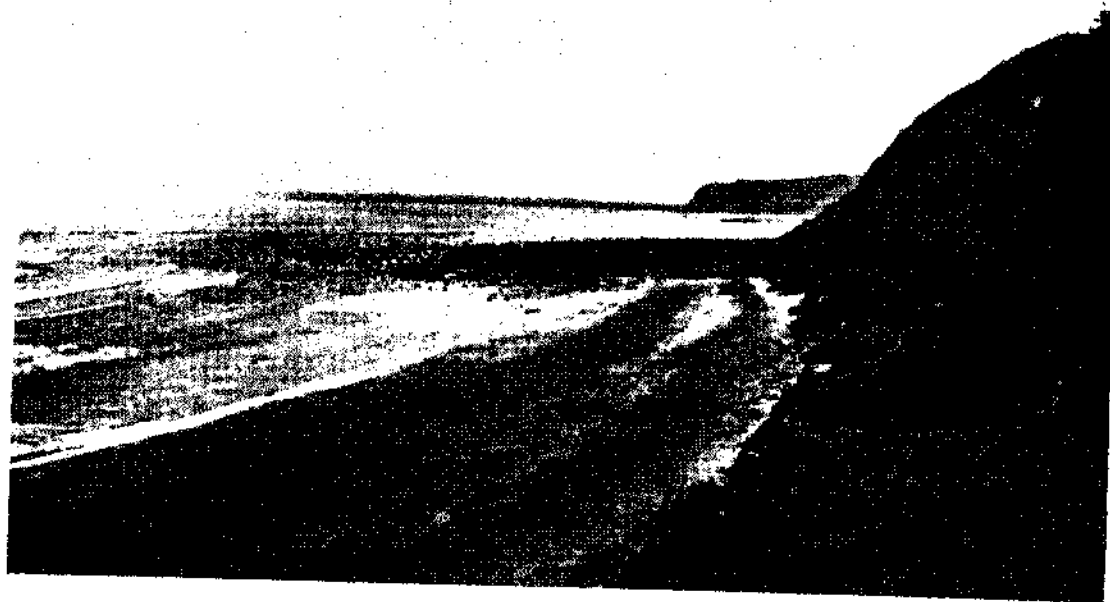

B. Bed-rock shoal Bear Boliaas, with clam patch near water edge. Dnxttry Point au3 reef is the distance. G. K. Q.



C. Olam patch near Bolinas. A bed-rock platform, exposed at low tide. Photographed November 25, 1906.



D. Salicornia in Liraantoor Bay. Photographed June 5, 1907, during low tide. Shows a platform covered by older growth, and a colony of Salicornia plants at a lower level.

of 1907, and it was then overspread by a fresh deposit brought by Papermill Creek. The ridges varied somewhat in height, the amplitude from crest to trough ranging from 1 to 3 feet and possibly more. Their general trend was parallel to the fault-trace, but there were notable exceptions, and over small tracts the direction was even at right angles to it. In some cases, where the minor ridges were parallel, there were larger ridges traversing them obliquely. Fig. 25 reproduces a sketch map of the locality showing the greatest complexity. So far as the broad undulations of the tide lands were seen in conjunction with the ridging, the greater ridges were on the swells and not in the hollows.

Without going deeply into the question of interpretation, it would seem that in the production of this ridging the tidal mud must have behaved as a quasi-liquid, being thrown into waves by the agitation to which it was subjected. When the agitation ceased it became once more a quasi-solid, and preserved the form it had at the moment of change.

There was also a horizontal shifting of mud over a considerable area. Residents familiar with depths of water in the vicinity of Inverness stated that the earthquake caused a decided shoaling along the coast, but that the relation of water levels to firm ground was unchanged. It was also stated that a channel which had existed parallel to the west shore of the bay, and to which piers had been run, was obliterated by the earthquake. The shoaling might have been caused either by an uplift of the bottom or by a shifting of the mud of which it is composed toward the shore. That the second of these explanations is correct seems to be shown by the following facts.

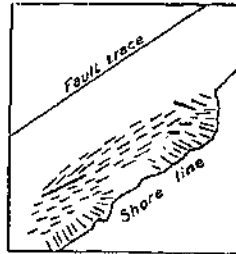
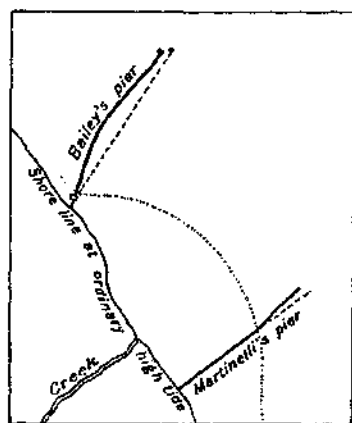
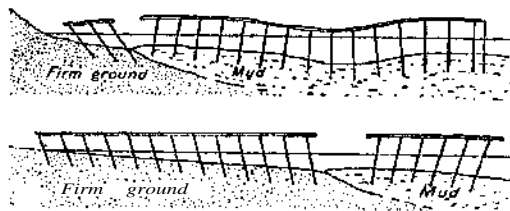

FIG. 25.—Arrangement of ridges on tidal flat near Inverness. Map.



26.



27.

FIG. 26.—Sketch of Inverness piers. Full lines show positions of piers after earthquake; broken lines show positions before earthquake. Dotted line shows shoreward limit of the shifting of bottom.

FIG. 27.—Diagrams with exaggeration of vertical scale, to illustrate deformation of Inverness piers by shifting of mud toward the shore. Bailey's pier above; Martinelli's below.

At various places along the shore, from Inverness to a point 1.5 miles southward, the tidal mud seemed to be crowded against the firmer ground at the shore, being pushed up in a ridge, as shown in the accompanying photograph. (Plate 55B.) TWO piers at Inverness, light wooden structures, resting on piles and extending out several hundred feet from the shore, were telescoped. (Figs. 26 and 27.) In the case of Martinelli's pier the telescoping was shown by the inclination given to piles at the landward and bayward ends, from which it appears that the ground in which the piles were set was crowded together, so that the foundation of the pier was shortened, while the superstructure resisted shortening. The resistance was temporary only, for before the agitation ceased the pier was broken in two; and the inclination of the piles is supposed to have been given during the early stages of the tremor. Coincident with the movement of the

ground toward the shore, there was a movement parallel to the shore which had the effect of offsetting the outer end of the pier about 25 feet toward the northwest. (Plate 57A.) The resultant of the two movements, or the actual direction of shifting of the mud, was westward, or a little to the north of west; and the maximum shifting in that direction was not less than 30 feet. Rather more than half the pier, the part nearer the shore, remained straight and suffered chiefly from the slanting of its supporting piles. This part stands on the submerged delta of a small creek, and its foundation appears not to have shifted. The outer part suffered most violence near the junction of the shifting mud with the firmer ground, being there so completely wrecked that its platform fell. The photograph and map represent it after repairs had been made.

In the case of Bailey's pier, which is beyond the delta, the most important telescoping, as shown by the slanting of piles (fig. 27), was close to the shore, and nearly the whole structure was transported by the shifting mud. It also sagged more than a foot just beyond the middle, and the attitudes of the associated piles suggest that the sag corresponds to a hollow made in the surface of the mud. The pier was so badly broken as to require extensive repairs, and in making these repairs Mr. Bailey used the old material for flooring, but found that he had enough lumber remaining for 12 feet of flooring, so that he inferred a shortening of 12 feet. The whole pier was shifted to the northwest, being given a curved form (plates 57B and 58), and the maximum amount of shifting in that direction was at least 25 feet, altho the circumstances did not admit of accurate measurement. Combining the movement toward the shore with the offset parallel to the shore, it is probable that the direction and the maximum amount of shifting were about the same as in the case of the Martinelli pier.

It is a notable feature of this displacement that the disturbed material moved up the slope instead of down, so that the transfer was not only independent of gravity but opposed to it. The phenomenon, therefore, does not fall in the same category with landslides, and if properly interpreted it may throw light on the mechanics of the earthquake pulses.

The area thru which the shifting of the mud took place is indeterminate. It affected a shoal parallel to the west shore of the bay and more than a mile long. At the piers the width of the affected region was at least 400 feet and may have been much more. The reported closing of the channel suggests 700 or 800 feet as a minimum estimate, but the outer margin of the affected area was probably beneath the water of the bay and outside the range of observation. The firmer part of the Papermill delta appeared not to be included in the movement. All of the area known to be affected lies southwest of the fault-trace, which in that neighborhood is about 2,000 feet from the shore.

#### THE QUESTION OF LOCAL ELEVATION AND DEPRESSION OF LAND.

*Introductory.* — Dr. C. Hart Merriam was told by an Indian living near Marshall, on the northeast shore of Tomales Bay, that since the earthquake the clam belt on that shore had been less accessible. The tides also came higher than formerly, the highest tides surrounding his cabin, whereas formerly they did not reach it. Mr. C. J. Pease, of Olema, also stated that the clam industry on the northeast shore of Tomales Bay had been much injured by changes due to the earthquake. Thru President D. S. Jordan I was put in communication with Dr. S. S. Southworth, of Bolinas, who reported various phenomena indicating a lowering of the land on the east side of the fault, and a lifting on the west side. On September 27 and October 15, 1900, being in Bolinas and its vicinity, I made a preliminary examination of some of the features described by Dr. Southworth. They were of such a character that it seemed desirable to enlist the aid of zoölogists and botanists, and to this end a conference was soon afterward called in



A. Martinelli's pier at Inverness. Originally straight; shifted and broken by earthquake. Repaired before photograph was taken. G. K. & G.

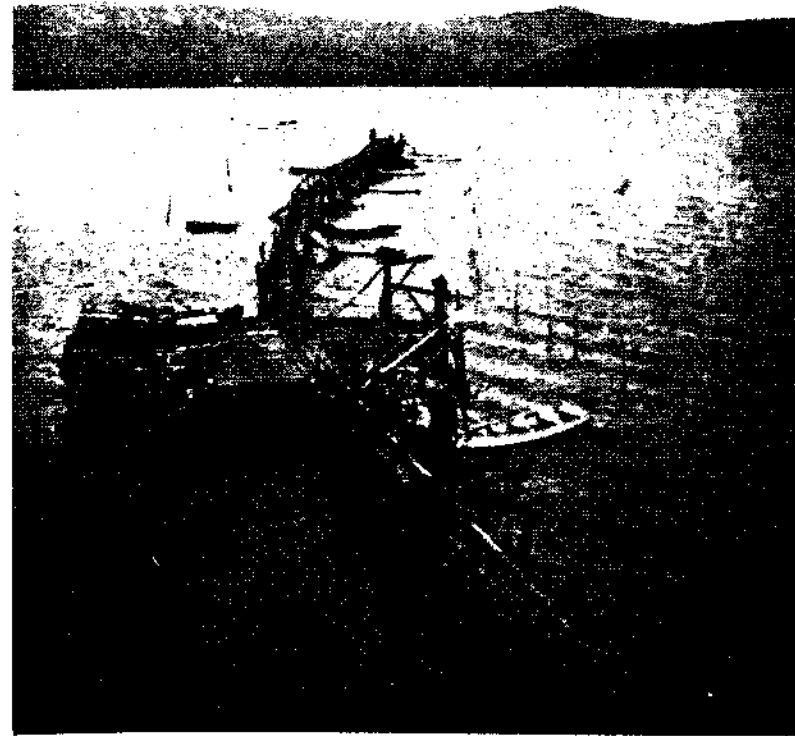

B. Bailey's pier at Inverness. Originally straight; shifted and much broken by earthquake. In subsequent repairs curvature caused by earthquake was retained. G. K. & G.

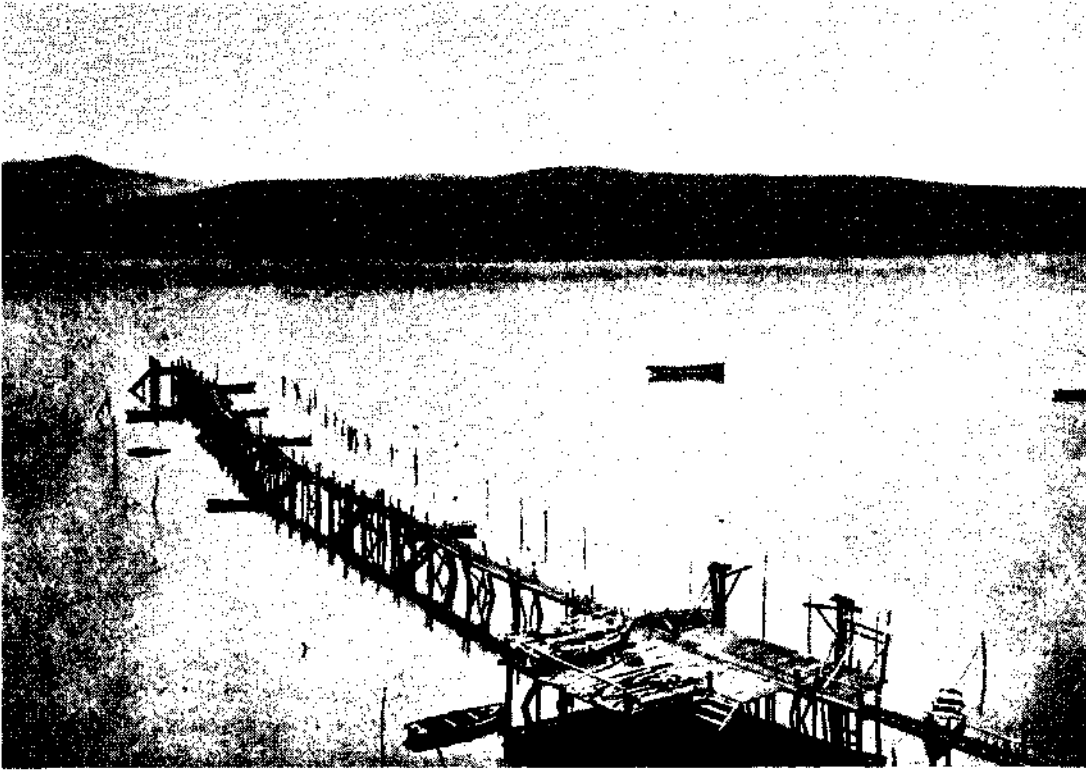

A. Bailey's pier at Inverness. Another view, position of camera being approximately same as in making photograph below, taken before the earthquake. G. K. Gh

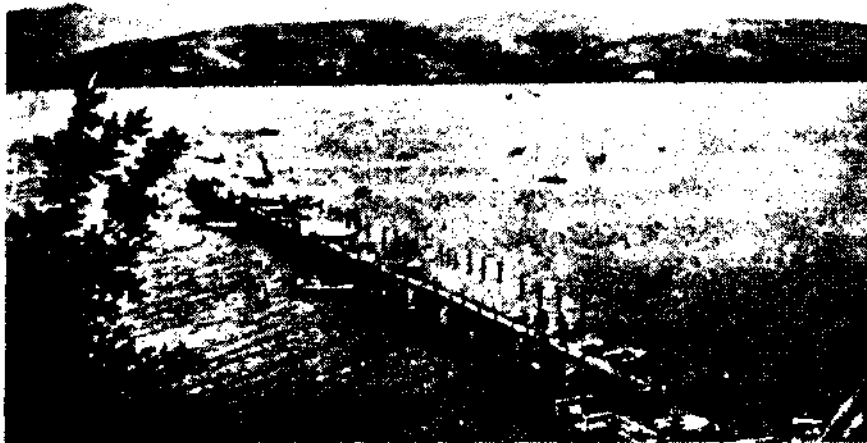

B. Bailey's pier at Inverness, before earthquake. Photographed by Martha F. Schreiber. Compare A of this plate.

Berkeley, and arrangements were made for field examinations by naturalists. On October 26 Professor William E. Bitter and Mr. E. L. Michael went to Bodega Bay, where they spent several days, and at the same time Profs. Chas. A. Kofoid, H. B. Torrey, and R. S. Hoiway visited various points on the shores of Tomales Bay and Tomales Peninsula. On November 24 and 25 Professor Kofoid accompanied me to Bolinas for the purpose of gathering such evidence as might be afforded by marine invertebrates. On March 8-9, 1907, Professor Holway and I visited Bolinas, and on April 9-10 I was accompanied by Professor Willis L. Jepson in the same locality. On April 18 I made an examination of the Papermill Creek delta at the head of Tomales Bay, and on April 22 visited the sand-spit separating Bolinas Lagoon from the ocean. The results of these various excursions are summarized below, and reports by Professors Ritter, Kofoid, Holway, and Jepson are appended.

*About Bolinas Lagoon.* — In presenting the evidence as to land-movements in the vicinity of Bolinas Lagoon, first place will be given to testimony of residents, and this again will be classified according to locality, beginning with the features west of the fault-trace.

Dr. Southworth has lived in Bolinas several years, and his activities during that period have led him into almost continuous observation of the coast and the tide. There is a clam patch on the ocean front between Bolinas and Duxbury reef (see fig. 28 and plate 56B), to which he has frequently resorted at suitable stages of the tide. It has been his custom regularly to consult the tide tables to ascertain whether the water stage would expose the patch. He reports that before the earthquake there were ordinarily about four low tides in the month, occurring by daylight, during which clams might be obtained, and that since the earthquake twenty or more days are available. He infers that the land was lifted at least a foot, possibly more, at the time of the earthquake. He states also that about 5 miles to the northwest there is a tract, exposed only at low tide, where abalones are abundant, and that people living near there have found them much more accessible since the earthquake than before. In Bolinas Lagoon a channel between Pepper Island and the mainland is not now navigable at certain tide stages which formerly made it entirely navigable.

Dr. Gleason, owner and master of a vessel plying between Bolinas and San Francisco, states that formerly it was his custom to turn his vessel in the channel between Pepper Island and the west end of the sand-spit, but that after the earthquake he found the place too shoal, so that, after a number of trials in which his vessel was grounded, he has adopted the practice of entering the lagoon stern first, to avoid the turn.

The following observations pertain to localities east of the fault. A road which skirts the northeast shore of the lagoon is not altogether on the mainland, but in places follows the strand between high and low water, and if it is used at high water the horses must ford. Dr. Southworth states that since the earthquake these fords have become more difficult, so that to pass them safely or comfortably they must be reached when the tide, as indicated by the tables, is lower than was formerly necessary. Mr. B. C. Morse, however, who lives on the mainland east of McKennan Island, and who ordinarily crosses the lagoon to Bolinas every day, states that he has noticed no change in the relation of

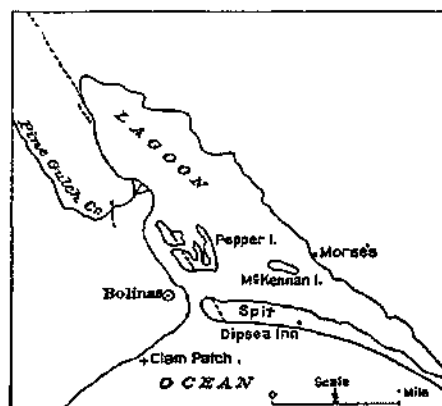

FIG. 28. — Sketch map of Bolinas Lagoon. Broken lines show fault-trace and its branches.

water to land along his water-front. Dr. Southworth has found the navigation improved at various places in the eastern part of the lagoon, the water being deeper than formerly for the same normal state of the tide, and this observation is confirmed by Mr. Morse, who now at high tide sails over a portion of McKennan Island which could not formerly be crossed with a boat. Various residents are of opinion that the sand-spit, except at its extreme western end, is lower than formerly. A lady who has lived at Dipsea Inn several years states that before the earthquake the spit was overtopped by waves only during storms with heavy winds, but that since the earthquake waves frequently wash over it.

It will be observed that all this testimony, with the single exception of Mr. Morse's observation of water-levels near his house, tends to show a general sinking of the land east of the fault, and a general rising of that to west of it.

Professor Kofoid, in seeking evidence from the distribution of marine life, found the barnacle the most available form. It is abundant at many places; its shell remains as a witness after the death of the animal, and its upward limit bears, at many places, a definite relation to the line of high tide. The best places found for observation were certain groups of piles at Bolinas and along the northeast shore of the lagoon. From a study of these localities it appeared that in the upper part of the barnacle zone the percentage of dead shells is notably greater on the west side of the fault than on the east side, but there is not a well-marked zone of dead barnacles on the west side, nor is there a zone of exclusive young barnacles on the east side. The evidence thus gives a qualified support to the theory of elevation and subsidence. Outside the lagoon, on the open sea-front, the upper limit of barnacles is too indefinite and irregular to be available for a study of this character.

Visiting Pepper Island in company with Professor Holway, I found the position of the fault-trace clearly indicated by a difference in the color of the vegetation. The island is low, only a narrow strip at the south remaining above water at ordinary high tide, and from this strip there is a gentle slope toward the north and northwest. The vegetation on the highest part is somewhat varied, but the lower slopes are occupied almost wholly by a single species of *Salicornia* (pickle-weed). This is locally the lowest lying of the shore forms, and it descends the slope to a somewhat definite line beyond which the mud is bare. It is evident, therefore, that its lower limit is determined purely by physical conditions and not at all by the competition of other plants. It is thus peculiarly sensitive to changes in the relation of land to water. West of the fault a broad area covered by this plant presented, at the time of the visit, a brownish-green color, while the adjacent areas east of the fault had a dull brown color. The contrast was so strong that the eye could readily trace the line of the fault. We found also that the ground east of the fault was, in general, lower than the ground at the west, and I afterward made a series of measurements showing the average difference in elevation to be 12 inches.

Pepper Island was subsequently examined by Professor Jepson, who not only traced the brown color of the *Salicornia* to an abundance of dead and dying plants, but found considerable corroborative evidence in the condition of other species living at slightly higher levels. On McKennan Island a similar condition was found. The island is girt by a zone of *Salicornia*, the outer or lower belt of which was found to be brown. A single measurement of the vertical range of dead and dying plants gave 10 inches.

The northeastern shore of the lagoon was examined for evidence of similar character, but the result was less satisfactory. The lowest plant growth is not everywhere the same and the local conditions are materially different. The slope is less gradual, the soil is more gravelly, and there is deposition of detritus eroded from the land by streams and waves. At some points a belt of plants at the extreme limit appeared to be suffer-



ing from some adverse condition, but elsewhere the normal green color was continued to the lowest limit. At the head of the lagoon and just to the east of the fault-trace is a considerable tract of *Salicornia*, of which the low-lying parts showed a brown color, but the distribution of vigorous and sickly plants was less simple than on the island and its causes were not fully understood. I afterwards visited the north slope of the spit to see if the condition of its vegetation corresponded to that on the islands, but found the evidence complicated by another factor. The overflow of the spit by waves during the past winter had washed a considerable amount of sand down the north slope, and this sand suffocated large tracts of *Salicornia* and other plants.

In the discussion of these data, the first point to be noted is that the killing of *Salicornia* thru the lower part of its zone definitely indicates a lowering of the ground on which it stands. The plant normally travels down the slope as far as it can tolerate the tidal submergence and there stops; and its inability to sustain itself in a well-defined belt constituting the lower part of its former range shows that the submergence in the belt has become intolerable. The amount of submergence is shown by observation on McKennan Island to be at least 10 inches, and if allowance is made for a certain amount of lag in the response of the plant to change of condition, the lowering of the land may have been several inches more than this. If McKennan Island and the eastern part of Pepper Island subsided the same amount, it is probable that the only change on Pepper Island was a subsidence of its eastern part, the western part remaining at its former level. In that case the amount appears sufficient to account for the overwashing of the spit, altho no measurement is there practicable.

The tract of land, whose subsidence appears to be demonstrated by the botanic evidence and the overtopping of the spit by waves, is bounded on the southwest by the fault, but its other limits are not known. In the immediate vicinity of the fault it may reach the head of the lagoon; that it does not extend beyond is rendered probable by the fact that there is no vertical dislocation in the fault-trace at a point about one mile northwest of the lagoon where the trace is favorably exposed on flat ground. It may be possible that the area of subsidence is limited on the northeast along an old line of dislocation which coincides approximately with the northeast side of the lagoon. This dislocation has not been determined by a study of the geologic structure, but is indicated by the physiography, and was presumably concerned in the making of the basin occupied by the lagoon.

The evidence of elevation west of the fault is less coherent. Dr. Southworth's observations on the clam patch give a presumption in favor of elevation, but they are not well supported by the evidence from barnacles and plants. The botanic evidence indicates that the entire dislocation shown by the measurement on Pepper Island is a subsidence on the east and does not include elevation on the west. The evidence from the barnacles suggests, without proving, a slight elevation at the Bolinas wharfs, but by no means indicates so great an elevation as would be necessary to account for the increased facility in reaching the clam patch. Dr. Gleason's report of the shoaling of water in a channel near Pepper Island undoubtedly shows a local change, but such a change may have been produced by a horizontal shifting of unconsolidated material such as occurred in Tomales Bay. On the other hand, it is not possible to explain the phenomena of the clam patch by a hypothesis of shifting bottom, for the sand in which the clams live is contained in shallow basins of visible bedrock, and any change in the relation of surface to tide at that point is a bedrock change. As the Rift belt with its numerous earlier dislocations extends nearly to the clam patch, it is not impossible that there were differential movements west of the fault-line and that the ground occupied by the clam patch and the abalone patch rose independently of the western division of Pepper Island.

*About Tomales Bay.* — Professors Kofoed<sup>3</sup>, Torrey, and Holway examined practically the whole shore of Tomales Bay, and also visited the outer or ocean side of Tomales Point. Their attention was directed especially to the condition of barnacles at the upper limit of the zone of marine life, and the evidence they found does not show any change in level, either by elevation or subsidence. It is their opinion that the injury to the clam industry along the northeastern shore of the bay is referable to other causes, including at some points the exceptional inwash of detrital material from the shore, and at others the shifting of loose material toward the center of the bay.

After the discovery of the vertical dislocation in Pepper Island, I visited the Papermill delta at the head of Tomales Bay in search of similar evidence of displacement, but failed to discover it. There are on the delta several tracts on which water stands after the fall of the tide, and the plant growth, especially *Salicornia*, shows deterioration in these areas; but the areas are not systematically related to the fault-trace. They occur on both sides and at least one of them is intersected by the trace. They constitute part of the evidence of a gentle, broad undulation of the delta surface, which appears to have been occasioned by the earthquake. A tentative theory to account for this undulation is that lenticular bodies of soft clay, included in the delta deposit, experienced a certain amount of flow during the earthquake period. The lane of water following the fault-trace, and described on an earlier page, is an independent phenomenon closely associated with the fault, and the depression causing it does not extend indefinitely toward the east. In a general way, the half of the delta east of the fault stands as high as the half at the west. On the lower slope of the delta, beyond the region of plant growth, there is a tract east of the fault which received the principal deposit of sediment brought by the floods of 1907. The localization of this deposit suggests that the transporting current may have been guided by a depression of the surface, but if so the depression was not bounded on the one side by the fault line; its southwestern boundary is a distributary of the creek. As the tract on which this deposit took place is opposite a portion of the tract in which mud was shifted toward the southwest shore, it seems possible that the area of shifting here included practically the whole width of the bay, and that the resulting elevation of the bottom toward the west was accompanied by a lowering of the bottom toward the east. In that case, the apparent lowering of the clam zone at various points on the northeast shore may be correlated with the phenomena near the head of the bay, and the whole ascribed to a general shifting of loose material in the bottom of the bay toward the west.

*Bodega Bay.* — As the title of Bodega Bay is variously applied on different maps, it is proper to specify that the body of water here intended is the land-locked lagoon east of Bodega Head, and not the open roadstead farther south. Professor Hitter examined this with care, studying especially the distribution of barnacles, and found no evidence of absolute or differential change of level.

*Summary.* — At Bolinas Lagoon, subsidence occurred east of the fault, its vertical amount being approximately a foot. The subsided tract included the greater part of the area of the lagoon, and may have had its eastern limit along the eastern shore of the lagoon. The subsidence was possibly a continuation of the local movement of dislocation by which the basin containing the lagoon was created. There may have been local elevation of a tract extending from Bolinas westward and northwestward. The evidence is not demonstrative, but leaves a presumption in favor of such elevation.

About Tomales Bay and Bodega Head there was probably no appreciable change in the general elevation of the land, most facts which tend to show such change being explained by assuming that in Tomales Bay there was a general shifting of mud and other incoherent material toward the west. Such shifting had been fully demonstrated in the vicinity of Inverness.

*Postscript.* — Since the preceding paragraphs were written, some additional data have been gathered bearing on the question of the elevation of land between Bolinas and Point Reyes. As the most satisfactory biological evidence with reference to changes in level had been found in the response of the plant *Salicornia*, it occurred to me that pertinent information might be obtained by examining the lower limit of land vegetation at Limantour Bay. That bay is an extensive, ramifying, drowned valley lying east of Point Reyes promontory. It is separated from the ocean by a spit, past the western end of which a channel is maintained by tidal currents, just as in the case of Bolinas Lagoon. The eastern end of the bay is at the western base of the ridge bounding the Bolinas-Tomales trough, and is 8 or 10 miles northwest of the abalone locality.

If the land in this locality was raised at the time of the earthquake, the height of the tide at all stages, with reference to the land, would be lower; and the lower limit of *Salicornia*, being dependent on the relation of the land to tide water, would descend the slope in response to the change in level. The feature, therefore, to be looked for was a new growth of *Salicornia* at a lower level than the older growth. Such new growth was actually found (June 5, 1907), not in a continuous belt, but in numerous patches having certain common characteristics.

At the points visited the tide marsh characteristically ends in a little step or bluff about 8 inches high. Above this step the gentle slope is covered by a mat of vegetation in healthy condition, the dominant plant near the step being *Salicornia*. Below the step is a mud surface, which usually inclines more rapidly than the platform above. If I understand the origin of this topography, the step has arisen from the gradual bayward extension of the platform, which, by reason of its vegetal covering, is enabled to arrest mud suspended in the water. There is also doubtless an accumulation of the roots and stems of the *Salicornia*. In places there are outlying platforms of the nature of islands and similarly covered by *Salicornia*. On the other hand, the broader platforms are interrupted by channels thru which the tidal waters escape, and there are also lake-like hollows abruptly margined by steps a few inches high. The slope below the step is ordinarily of bare mud, but on it are numerous patches of young *Salicornia*, and there are similar tracts in tidal channels and in some of the lake-like hollows inside the platform. The vertical range of this young growth is quite definite, its lower limit being from 13 to 16 inches below the outer edge of the platform. In some cases the young growth is straggling, but usually it makes a mat as close and complete as on the platform above, and the height is nearly as great. It is distinguished from the older growth chiefly by a slight difference in color. Whether such a luxuriant and dense growth of *Salicornia* could be produced in the period of 13.5 months, I am not prepared to say. Except for that doubt, however, the phenomena are just such as would be expected to follow an elevation of the land.

In an estuary at the edge of the bay were two fence stakes on which barnacles were set. At the upper limit of the barnacles, I examined a dozen individuals, finding them all alive, and I saw none of the adherent plates which remain after the death of the old barnacles. I did not learn the history of these stakes. If placed after the earthquake, the evidence of the barnacles would not be in point. If placed before the earthquake, the evidence of the barnacles, so far as it goes, is opposed to that of the new colonies of *Salicornia*.

*Second Postscript, added to proof sheets in November, 1907.* — Early in October, 1907, Dr. S. S. Southworth reported that the clam patch near Bolinas had again become less accessible, its relation to tides being practically as before the earthquake. The apparent change was not associated with any precise date, but it had been suspected since the middle of summer. On October 17 I visited the locality, selecting a time when the predicted sea-level at low tide was approximately the same as on November 25, 1900, when I had taken the photographs reproduced in plate 56B and plate 56c.

For November 25, 1906, the predicted height of low-water at the San Francisco entrance was 2.1 feet; for October 17, 1907, 2.2 feet. The comparison of the clam patch with the view made eleven months earlier showed a marked difference, a much larger area being submerged at the later date. Four days afterward, when the predicted height of low-water was 0.3 foot, I again compared the appearance of the clam patch with the photograph, finding the water-stage somewhat lower than when the photograph was made. As the tide rose its stage was found to coincide with that shown by the photograph one hour after low-water, and the calculated allowance for the corresponding change in water-level at the San Francisco entrance is about 0.3 foot, so that the predicted tide-stage for that moment was 0.6 foot. As the predicted stage at the time represented by the photograph was 2.1 feet, there was an apparent discrepancy of 1.5 feet. If this was occasioned by a change in the height of the ground at the clam patch, then there was a subsidence of 1.5 feet between November 25, 1906, and October 21, 1907. Before accepting so important a conclusion it should be checked in every practicable way, and especially by comparing the water-stages at the clam patch with simultaneous water-stages as recorded at the tide-gage station of the U. S. Coast Survey in the entrance to San Francisco Bay. The distance of that station from the clam patch is about 15 miles, of which one mile is inside the narrowest constriction of the Golden Gate. On the days of observation at the clam patch the sea was calm, except for a moderate groundswell, so that the normal equilibrium of the water-surface between that point and the tide-gage was presumably not impaired by meteorologic influences. Off the clam patch the groundswell broke at a distance from the shore, leaving the water so quiet at its actual margin that its level could be observed with little error. The general and local conditions were thus favorable for a comparison of water-stages at the two points; and the numerous details of the photograph of November 25, 1906, made it possible to identify, with close approximation, the arrival of the tide at the same plane on October 21, 1907. The observations at the tidal station, for which I am indebted to Capt. Aug. F. Rodgers, Assistant U. S. Coast Survey, were made with the tide-staff at low-water, and are referred to the arbitrary zero of the tidal station.

	FEET
At low-water on the afternoon of Nov. 25, 1906, the tide-staff reading was . . . . .	6.10
At low-water on the afternoon of Oct. 21, 1907, the tide-staff reading was . . . . .	5.61
In the hour following low-water the computed rise of the tide was 0.3 ft.; and this gives as the height of water at the time of the observation at the clam patch . . . . .	5.91
Difference . . . . .	<u>.19</u>

Thus the discrepancy of 1.5 feet, deduced from a consideration of the predicted tides, is reduced by a comparison of the observed tides to about 0.2 foot, a quantity so small as to be referable to errors of observation.

Before tide-gage records were obtained I had revisited Pepper Island and Limantour Bay. On Pepper Island the vertical dislocation was remeasured and found to be unchanged. At Limantour Bay the subject of examination was the condition of the new growth of *Salicornia*. If the land had subsided since the preceding June, the colonies of *Salicornia* which had invaded the mud flat (plate 56D) would have been subjected to unfavorable conditions, and might be expected to show the influence of those conditions. All the colonies that had previously been observed were reexamined and they were found, without exception, to have deteriorated. The green heads, which had formerly testified to their lusty growth, had become much less numerous and were modified in color; their stems were blackened on the surface and had become somewhat curled, and in general they appeared less healthy than the plants of the same species growing at higher levels. Where the slope was continuous, there was a fairly sharp line of separation between the healthy and unhealthy plants, and two measurements indicated the zone of impairment to have a vertical range of 10 inches.

The comparative observations of water-stages show that the land at the locality of the clam patch has not recently undergone the suspected depression, as compared to land at the tidal station near San Francisco. If an important change has taken place at one locality, it has affected the other also. On the other hand, it is noteworthy that Dr. Southworth's observations at the clam patch (first of its increased accessibility, and after of its decreased accessibility) led to two predictions as to the condition of *Salicornia* in Limantour Bay, both of which were verified. Their success in prediction gives assurance that they record an actual change of some sort — a change not restricted to the locality of the clam patch. The two lines of evidence taken together — the leveling by water-plane from the tide-gage to Bolinas, and the observation of shore conditions at Bolinas and Limantour Bay — suggest the possibility of a general change in the relation of land to sea, affecting the whole coast from San Francisco to Limantour Bay. So far as the observations go, such a change might pertain to either land or sea. In the line of this suggestion it is to be noted that November 25, 1906, falls within a period of exceptionally low tides at San Francisco entrance. For 21 low tides, from November 20 to November 30, the mean of the observed heights was 1.08 feet below the mean of the predicted heights. From October 17 to October 21, 1907, on the other hand, the mean of 10 observed tides was only 0.32 foot below the corresponding mean of predicted tides. The subject appears to deserve further investigation and discussion than is practicable while these pages are in press.

The observations which occasioned this postscript, while suggesting lines of enquiry which may profitably be followed, do not materially affect the conclusion already summarized as to local changes in the elevation of the land. A tract, including the east part of Pepper Island and much of the area of Bolinas Lagoon, subsided at the time of the earthquake, the amount of subsidence at the point of most satisfactory measurement being 12 inches. The region west of the fault, including the ocean coast from a point near Bolinas to Limantour Bay, may or may not have been uplifted at the same time, and may or may not have subsequently subsided. The evidence is incomplete and apparently somewhat conflicting.

Special reports on the biologic evidence follow.

## REPORT ON A BIOLOGICAL RECONNAISSANCE OF BODEGA BAY REGION.

BY WILLIAM E. RITTEK.

Accompanied by Mr. E. L. Michael, I examined the Bodega Bay region on October 26-30, for evidences of a faunal modification resulting from the earthquake of April 18, 1906.

My first effort was to secure information from residents of the district bearing on the question. A number of families living on the shores of Bodega Bay have their dwellings close to the water's edge. Since the bay is small, closely land-locked, and hence especially free from surf, and since these families spend much time on the water with their small boats, which they beach on the gradually shelving shores or tie to their little private piers, it seemed that their testimony would be peculiarly reliable. It appeared that any appreciable change of level of the water along the shore or any noticeable effects on the shore life would hardly escape detection. I talked with five persons of this sort, each by himself. All were unequivocal in affirming that neither the level of the water nor the animal life of the bay were in any wise altered by the earthquake.

The earthquake fault at the only point at which it has been located here, passes thru the sand-dunes at the head of the bay; and from its general course and the place where next observed to the south, must have past nearly parallel with the eastern shore of the bay and either have followed the shore or have been to the landward of the shore. In other words, nearly if not the whole of the bay, together with the peninsula of which Bodega Head is a part, is on the west or seaward side of the fault. All the facts we were able to gather by direct observation pertain to the rocky shore of the bay side of the peninsula. Since the rock here is a firm granite, and since in some localities the walls are nearly perpendicular, are even-faced, and are washed by the waters thruout the day excepting at extreme low tide, they are very favorable for furnishing testimony of the kind sought. The question to be answered was: Do the organisms that live immovably fixed to the rocks show evidence of having either extended or withdrawn the upper limit of their vertical distribution within recent time? The organisms that would be available as testimony would be those that are most permanent in structure, and extend up to the very limit of the high tide. Of first importance are the barnacles, two species, *Balanus balanoides* and *Chthamalus stellatus*. A species of *Mytilus*, and perhaps one or two species of marine algae, are also more or less available. Our attention was given to the barnacles chiefly, but somewhat to the mussels also. Neither of us was sufficiently familiar with the algae to make much use of them.

We could get no evidence that any of these organisms had either extended or withdrawn their limits of distribution. In the absence of accurate knowledge on the rate with which barnacles develop, there might be some uncertainty as to whether the limits had been extended; since, however, the individuals at the upper limit were not found to be in general smaller than those farther down; and further, and still more importantly, since the remains of dead individuals were quite as numerous proportionally in the upper zone of distribution as in the lower, we could but conclude that there was an absence of evidence of extension. In other words, there was no evidence of subsidence of the shore.

As to the question of whether the shore has been elevated at this point, the evidence I think is more positive. Not only is there lack of proof that elevation has occurred, but there is ample proof that it has not. This is furnished by the barnacles chiefly. On the vertical granite walls above mentioned, these organisms almost completely cover the surface up to about 7 feet above mean low water. As already stated, the remains of dead individuals are uniformly distributed thruout the area; or, to speak more accurately, they are not more numerous proportionally in the upper limit of distribution than in any other portion, as would surely be the case had the upper limit been lifted above the former high-water mark. It should have been pointed out that the 7 feet to which the barnacles extend must be very near, if not quite the limit, of high tide.

^ The character of the remains of dead animals is such as to preclude, I believe, being misled by the facts. In addition to the heavy calcareous wall which characterizes the superstructure of the animal, there is a well-defined continuous platform closely fused to the substratum to which the animal adheres. After death the superstructure of the shell falls away, leaving the platform as a smooth, hard, calcareous scab clinging to the rock. This is very durable, as one can see by observing old piles that have been taken from the water and to which these barnacle remains cling. Had any appreciable elevation of this shore occurred, there would surely be a zone of dead barnacle shells at the upper range of the distribution. The testimony of the mussels, so far as it goes, is confirmatory of that furnished by the barnacles.

## REPORT ON A BIOLOGICAL RECONNAISSANCE OF TOMALES BAY REGION.

BY CHARLES A. KOFOID.

On October 26-28, 1906, in company with Profs. H. B. Torrey and R. S. Holway, I made an examination of the shore of Tomales Bay to obtain evidence of faunal modification resulting from the earthquake of April 18, 1906. The places specially examined were as follows: the northeast shore from Millerton to Preston Point; Hog Island near the mouth of the bay; the southwest shore from near Tomales Point to the region opposite Marshall, and from Inverness to the head of the bay. The outer face of Tomales Point was also explored for a short distance near "Shell Beach."

Search was made for evidence of a change in level in the two sides of the bay and especially for evidence of depression of the northeast shore and elevation of the southwest shore. For this purpose critical examination was made of barnacles *in situ* on rock in place along the shores between tide levels. The fauna of the bay includes no generally distributed organisms attached to rock within tide levels except the barnacles (*Balanus* sp.). Mussels are rare and there are very few attached seaweeds far from the mouth of the bay.

The barnacles are, however, sufficiently abundant and widely distributed to afford an excellent index to any recent change in levels. If the northwest shore line, about 0.5 to 1.5 miles from the main earthquake trace, had been depressed even a few inches we might expect to find young barnacles, the young of the year which are easily distinguished by their brownish-gray color, softer texture of the shell, and certain structural features, invading the new territory above the old to an extent equivalent to the depression. If the southwest shore had been elevated, we should expect to find a number of dead barnacles in the region above the old barnacle limit and a relative absence of young in the upper levels. The upper limit of the growth of barnacles lies below the level of highest tides, and is more or less distinctly marked, according to the exposure to prevalent currents and wind and to exposure to the sun; and it is also modified by the slope and texture of the substratum.

The two shores present strong contrasts in the matter of exposure to prevalent winds, to the sunshine and in the texture of the substratum, the rocks of the northeast shore belonging to the Franciscan, more or less metamorphosed, and those of the southwest shore being of a granitic nature. These contrasts produce considerable modifications in the distribution of the barnacles.

A critical examination of the data reveals *no conclusive evidence of any recent change in the distribution of barnacles that can be attributed to a change in the levels of rocks in place.* There is no sharp and uniform contrast between the two sides of the bay in the matter of the distribution of these organisms. There is no uniform or extensive invasion of higher levels by young barnacles on the northeastern shore and no marked destruction of old barnacles and absence of the young at high levels on the southwestern shore. The conclusion is reasonably certain that there has been no appreciable change in levels of either shore as a whole.

Especial care was taken with the examination of the rocky shores of Preston Point which is crossed by the main fault, but even here there is no biological evidence of a change in levels on the two sides. In many regions barnacles have been killed in great numbers, apparently by silt in the waters. In other cases barnacle-coated substrata have been shifted with the mud, sand or gravel in or on which they lie, but such changes are of a local or superficial character. Hog Island, which lies very near the line of the fault but is not crossed by it, shows no uniform change in its barnacle fauna. The outer sea-cliff of Tomales Point, though very much shattered and with considerable talus from rock falls resulting from the earthquake, shows no disturbances in its fauna traceable to seismic movement. Local testimony of dealers in fish, of fishermen and of clam diggers indicates a great falling off in shipment of clams since the earthquake, traceable to departure of clam diggers, destruction of clams in places, by shifting of clam beds or their burial with detritus from cliffs. No change of levels which might not be traceable to shifting of loose deposits was noted.

There was local testimony of increased wash along the railroad embankment skirting the northeastern shore, or sinking or rising of known shoals in the bay, and of a depression of the gravel spit on which the fishing village stands. Probably all of these phenomena are explicable as the results of local loosening up of the railroad embankment and shifting of loose deposits, rather than as a result of a general movement of the earth's crust.

REPORT ON A BIOLOGICAL EXAMINATION OF THE BOLINAS LAGOON REGION,  
NOVEMBER 24-25, 1906.

BY CHARLES A. KOFOID.

*Bolinas Lagoon.* —The distribution of barnacles along the shore, on the piles, etc., was examined with reference to possible changes in level, near Bolinas wharf on the western side of the lagoon and on Morse's wharf on the eastern side, the principal locations on which barnacles occur about the bay. In neither case was there evidence or local testimony of disturbance in levels of the ground on which the barnacle-bearing substrata were located. The possibility of local slumping of soil is not, however, entirely excluded. No barnacles on rock in place were observed in the bay.

There is no evidence from the distribution of barnacles of any change in level of the eastern side of the bay. There is neither any marked destruction of old or absence of young in the upper levels such as would follow elevation, nor any marked recent occupation of an upper belt by young barnacles such as would follow depression. On the western side of the bay, on the piles of the warehouses at the landing, there was a faintly defined zone 6 to 8 inches wide in which the proportion of dead barnacles was unusually large. The percentage of dead in the uppermost levels on Morse's pier on the eastern side of the bay varied from 2 to 35 per cent with predominant range of 10 to 20 per cent. On the piles on the western side at similar levels, the proportion of dead was predominantly 40 to 60 per cent and not infrequently ran above these figures. Below this upper belt there was frequently less destruction and a relatively greater number of young than was found in the uppermost levels. It may be that this destruction was due to elevation, tho the uppermost belt of barnacles is still just submerged at a 5.4-foot tide. It might also be due to the considerable increase of silt attendant upon the large amount of talus shaken into the bay and along the adjacent shore line by the earthquake. The fact that barnacles attached themselves to and thrived on buildings thrown into the bay not far from the piles in question, would indicate that destruction by silt was confined to the time of the earthquake or that destruction did not take place as a result of silt.

The "studio building" at Bolinas, which was thrown into the bay by the earthquake and raised some months later, was well covered on submerged portions by barnacles, mainly half or two-thirds grown. This fact makes it certain that the young barnacles have been attached in large numbers since the earthquake, and that their distribution, therefore, affords critical evidence of change in levels.

*The Sea Coast Line.* — The evidence here from the distribution of barnacles is inconclusive, owing to the great range of movement of water in the breakers and the relative scarcity and small size of the barnacles present. There was no evidence of any change of levels, but their numbers are probably too small to afford evidence of a movement of a few feet only.

*The Clam Patch.* — The evidence of elevation here is entirely in the nature of testimony. The barnacles on rock in place in this region are too near the low-tide level to afford a satisfactory criterion. A few rocks in place near the upper levels show no trace of extensive destruction of barnacles such as might follow an elevation of 1.2 feet which Dr. Southworth believes to have taken place. But here again the biological evidence is too incomplete to have much weight. There is no doubt that there were clams in a shallow gravel bed resting on rock in place and abundantly exposed at a 2.1-foot tide.

In my opinion, from the evidence in hand, there was no depression of the eastern margin of Bolinas Lagoon as the result of the earthquake of April 18, 1906. Dr. Southworth's testimony, taken in conjunction with the destruction of barnacles in the upper levels on the western side of the bay, suggests the possibility of a small elevation on that side.



## EXTRACT FROM REPORT ON A RECONNAISSANCE OF TOMALES BAY REGION.

BY R. S. HOLWAY.

Below is a copy of the few notes made by me during the trip to Tomales Bay, October 26-28, 1906. The object of the trip was to examine the shore lines of the bay for indications of recent changes in level as shown by the effects on animal life. Drs. Kofoid and Torrey, the biologists of the party, recorded observations in detail and I have merely the general note as follows:

"The upper limit of barnacles was found to be a quite sharply defined line on the rocky shores of the bay. Any recent change in level of a foot or more would have been easily detected in *my* judgment. No evidence of such change was found. . . ."

## REPORT ON AN EXAMINATION OF PLANTS ON PEPPER ISLAND, BOLINAS LAGOON, APRIL 9, 1907.

BY WILLIS L. JEPSON.

*Salicornia ambigua* Michx. Pickle-weed. — This is the most abundant species and forms extensive colonies on both sides of the fault-trace. The difference in color of the areas on the two sides of the trace at once strikes the eye, the east area being dull or dead brown, the area west a livelier or greenish brown. This difference in color was found to be correlated with a difference in health. The plants west of the fault are in normal condition; the plants east of it are either dead or dying. Dead plants still standing show wasted or shrunken black stems. Dying plants show shrunken main axes bearing above a few short joints of green which are very much thicker than the main axis. In the normal plant the joints are no thicker or scarcely thicker than the main axis. A broad and very marked zone of dead or dying *Salicornia* surrounds McKennan Island which lies east of the fault.

*Statice Limonium* L. var. *californica* Gray. Sea Lavender. — Rather common in small areas on both sides of fault-trace. West of the fault plants are in normal condition, with large bright green leaves. East of the fault plants are dead or unhappy. Dead plants consist of nothing but caudices or short branching stems which form miniature forests of black stumps in the lowest places. Unhappy plants are those struggling to maintain existence and showing only a small tuft of small leaves. Similar colonies of dead plants were found on McKennan Island.

*Grindelia cuneifolia* Nutt. Marsh Grindelia. — The majority of the plants east of the fault are dead. Many plants west of the fault are dead, especially immediately west of the fault. The dying out is, in the main, doubtless due to old age in the colony.

*Mesembryanthemum cequilaterale* Haworth. Sea Fig. — Plants immediately west of the fault were healthy. One plant was found immediately east of the fault; this was killed completely.

*Distichlis spicata* (L.). Salt-grass. — Plants west of fault were thriving more than plants east in adjacent areas. (This species ranges to 600 feet above the sea.)

*Frankenia grandifolia* C. and S. Yerba Reuma. — Similar slight differences as in the preceding case.

*Triglochin maritima* L. Arrow-grass. — Coming up freely like young blades of grass west of the fault. Not appearing at all or reluctantly on east side.

*Jaumea carnosa* Gray. Fleshy Jaumea. — Less readily found on the east side of the fault. Plants on the west side were in somewhat better condition.

*Populus* species. Planted. — All individuals on east side of fault were dead.

*Summary.* — The difference in the health of the plants east and west of fault-trace indicates comparatively recent changes in conditions and would be explained by the assumption that there had been a change of level east of the fault. If there has been no such change it would be difficult to say why the affected areas should conform closely to the fault-trace. The plants on McKennan Island were also examined. The argument in favor of assuming a depression for Pepper Island east of the fault would hold good for McKennan Island. On the other hand, I should be strongly against the opinion that the condition of shore-line plants indicated a change in level on the east shore of Bolinas Lagoon.

## MUSSEL ROCK TO CRYSTAL SPRINGS LAKE.

*Course of the fault-trace.* — The point at which the fault-trace intersects the shore, on emerging from the ocean on the south side of the Golden Gate, is only approximately known. About 0.875 mile to the southeast of Mussel Rock, it has been located with precision at its intersection with the wagon road on the west side of the coastal ridge a little below its crest, and thence followed continuously for many miles. Projecting its course, there determined, in a northwesterly direction, it would pass out to sea in the midst of the large landslide which scars the coast immediately to the north of Mussel Rock, where the basal beds of the Merced series rest upon the older rocks. At the time of the earthquake there was an extensive movement of the landslide, and a tongue of landslide material, about 50 feet high and about 200 feet wide, was projected into the ocean across the narrow strip of beach.<sup>1</sup> This movement naturally obscured all evidence of the position of the fault-trace, which was doubtless overridden by the slide. All about the crest to the east of the landslide, and on its south side, the ground was greatly disturbed by fresh landslide cracks, scarps, and fissures, extending well back from the edge of its encircling cliffs. It appears to be probable that not only did the movement of the landslide obscure the evidence of the fault-trace, but also that the latter was here diffuse and scattered, and that the displacement was superficially taken up by the plasticity of the landslide material.

From the point southeast of the Mussel Rock slide where the fault-trace resumes its definite and easily recognizable character, to Crystal Springs Lake, our information regarding the course of the fault-trace and the earth movement on the fault is in part from observations made by Mr. Robert Anderson, and in part from observations recorded in a paper by Herman Schussler,<sup>2</sup> supplemented by the observations of Mr. H. O. Wood, Andrew G. Lawson, and others.

South of the road, at a point 0.875 mile southeast of Mussel Rock, begins the furrow which marks the surface path of the fault. The furrow as such does not cross the road to the north of this point. The side-hill slope, however, is very much fissured by landslide movements both above and below the road, and scarps are seen. From this point, the furrow runs uninterruptedly southeastward to the east side of the north end of San Andreas Lake, where, with a course of about S. 33° E., it passes beneath the waters of that reservoir. As it approaches the lake, the trace of the fault does not lie in the axis of the valley, but runs along its eastern side. It thence passes thru the lake on the north-east side, crossing a number of small promontories, to the east end of San Andreas dam; thence, with a course of S. 37° E., it traverses the east side of the valley between this dam and Lower Crystal Springs Lake, passes thru the latter and intersects the old dam between Upper and Lower Crystal Springs Lakes. Beyond this it skirts the southwest side of the upper lake, partly in the water and partly on the projecting points, and finally leaves the lake about a 0.25 mile from its end, for the stage of the water of April, 1906, having here a course of S. 40° E.

The mean course of the fault, as thus closely followed from the vicinity of Mussel Rock to the end of Upper Crystal Springs Lake, a distance of about 15 miles, is S. 36° 30' E. But the trace is not a perfectly straight line. Between Mussel Rock and San Andreas

<sup>1</sup> According to the observations of Mr. H. O. Wood, this projecting tongue of landslide had been entirely removed by the action of the waves, and alinement of the beach and sea-cliff had been reestablished.

<sup>2</sup> The Water Supply of San Francisco before, during, and after the Earthquake of April 18, 1906, and the Subsequent Conflagration. New York, 1906.

dam, the trace of the fault is slightly concave to the straight line connecting these two points on the fault, the concavity being to the southwest. Between San Andreas dam and the end of Upper Crystal Springs Lake, the trace of the fault is again slightly concave to the straight line between these points, but is on the opposite side of the fault, the concavity here facing the northeast.

*Characteristics of the fault-trace.* — For this stretch of from 14 to 15 miles, Mr. Robert Anderson, who examined this territory under direction of Prof. J. C. Branner, describes the trace of the fault as marked by a belt of upturned earth resembling a gigantic mole-track. The rupture may be traced along every foot of the way when not below the waters of the lakes. It varies in width from 2 or 3 feet to 10 feet, but at times branches out into several furrows that include a space of 100 feet or more in width. Such branches sometimes join again after a short interval. Sometimes it forms a crack 2 or 3 feet wide and several feet deep, and in other places shows a vertical wall of soil on one side or the other, several feet high. The typical occurrence in turf-covered fields is a long, straight, raised line of blocks of sod broken loose and partly overturned. It is thus shown in plate 61A,B.

Associated with the fault fractures are many lateral cracks, extending away from the fault in a northward, or north slightly eastward, direction; that is, at an oblique angle to the northeast side. These cracks were especially abundant along the northeast side of the northern half of Crystal Springs Lake, and between there and San Andreas Lake. In places they run off every foot or few feet for a distance of 100 yards or more, and again they do not form for some distance. They vary in size from minute crevices in the earth to fractures a foot or more in width. Here and there they form lines of broken sod very like the main furrow in size, while they have a length of from a few feet to several hundred feet. At the great dam at the head of San Mateo Canyon, these cracks emerged from the lake and ran northward up on the hills for several hundred yards, breaking the fences where they crost. Plate 16A shows large lateral cracks of this description, already partly filled up, crossing a road that runs parallel to the fault at the upper end of Crystal Springs Lake. The main line of fracture is about 50 feet beyond the fence, and the cracks extend into the foreground at an angle of from  $35^{\circ}$  to  $40^{\circ}$  with the main fault-trace. The fence is pulled apart 40 inches in the two places which are shown in the photograph, and a total of 10 feet in ten different breaks in this locality, within a distance of 200 yards. Such lateral cracks as these were not noted on the southwest side of the fault.

The lateral cracks described above make an angle of  $45^{\circ}$  to the general line of the fault fracture. They appear to have been produced very much like the fracture lines in compression tests of building stones. There was evidently great pressure holding together the two faces along the fracture. A dam made of earth and rock divides Crystal Springs Lake into two parts. This dam crosses the fault-trace at right angles, and was offset but not badly cracked or injured by the movement. The fences that line the road were warped and their boards buckled thruout the distance across the dam. The earthquake rendered them too long for the distance from the hills on one side of the valley to those on the other. The inference is that a strong compression took place. The slicken-siding shown in plate 62A furnishes further evidence of compression. In the same way the heaving up of the sod into a long, raised mound, for most of the extent of the furrow, suggests lateral pressure. The formation of cracks a few inches to 2 or 3 feet wide in places along the furrow seems to contradict the theory of compression; but these are regarded as due to the irregular, crooked fracturing of the surface and the faulting of irregularities into juxtaposition with one another near the surface. The open cracks

were never found to be of great extent, but were usually followed by stretches along which the earth was heaped up into a mound, as if by being prest together. The surface furrow indicates that there was a zone of crushing some 2 or 3 or more feet wide. Where a similar cross-section of the fault is viewed from the opposite direction, no such face is exhibited on the northeast side, but instead a mass of crushed earth projecting beyond its former position.

*Offsets of fences, pipes, dams, etc.* — About a mile southeast from the point near Mussel Rock where the furrow was first noted as a clearly defined feature, the fault-trace passes thru the trough of a well-marked saddle. This feature is more accentuated than similar features at other points along this portion of the rift, tho many such are found. Southeast from this saddle there is recognizable in the topography a distinct line of former movement, lying east of the fault. No furrow follows the line continuously, but an occasional

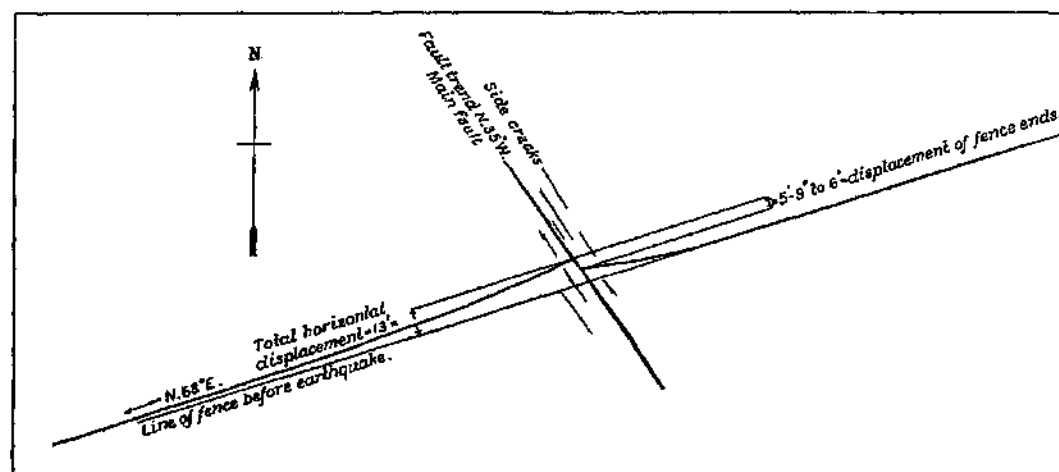

FIG. 29. — Offset fence southeast of Mussel Rock, showing distribution of deformation on either side of fault.

short fissure or crack runs along it for a little way. To the west of the place is a similar, but less well marked, topographic indication of a former movement. There is no evidence of any movement on this line at the time of the earthquake. At the point where the fault-trace crosses the road, less than half a mile farther on, the roadway and fence were broken, but the effects were so confused that the measure of the offset could not be determined. The apparent horizontal displacement was slight.

Still farther to the southeast, about 1.25 miles, the fault intersected a fence and not only caused it to be offset, but the intersection showed clearly the effect of the drag in the earth movement. The bearing of the fence is N. 68° E., so that it is approximately transverse to the line of the fault. On the west side of the latter, the fence suffered a displacement to the northwest of 13 feet from its former position, and this displacement was effected by a bending or curvature in the fence line extending westerly from the fault for a distance of over 200 feet. On the east side of the fault, the fence was bent away from its former position, *in the same direction*, about 7 or 7.25 feet, the bent portion extending easterly from the fault-trace about 45 feet. The two ends of the fence were thus offset on the line of the fault only 5.75 to 6 feet, altho the total displacement was 13 feet. The displacement is shown diagrammatically in fig. 29. At a point 330 yards beyond this, on the Rift, the fault-trace was found to be confined to a furrow about 6 feet wide, passing thru a little trough between an outcrop of Franciscan on the west and a fine conglomerate (Merced) on the east.

Nowhere along this portion of the fault-trace between the slide at Mussel Rock and San Andreas Lake was there observed any definite evidence of vertical displacement. There was a hint of slight upthrow on the western side, but it could not be tested by measurement. There were, in general, furrows on either side of the main fault, at various distances up to 200 feet. Some of these were persistent for considerable distances.

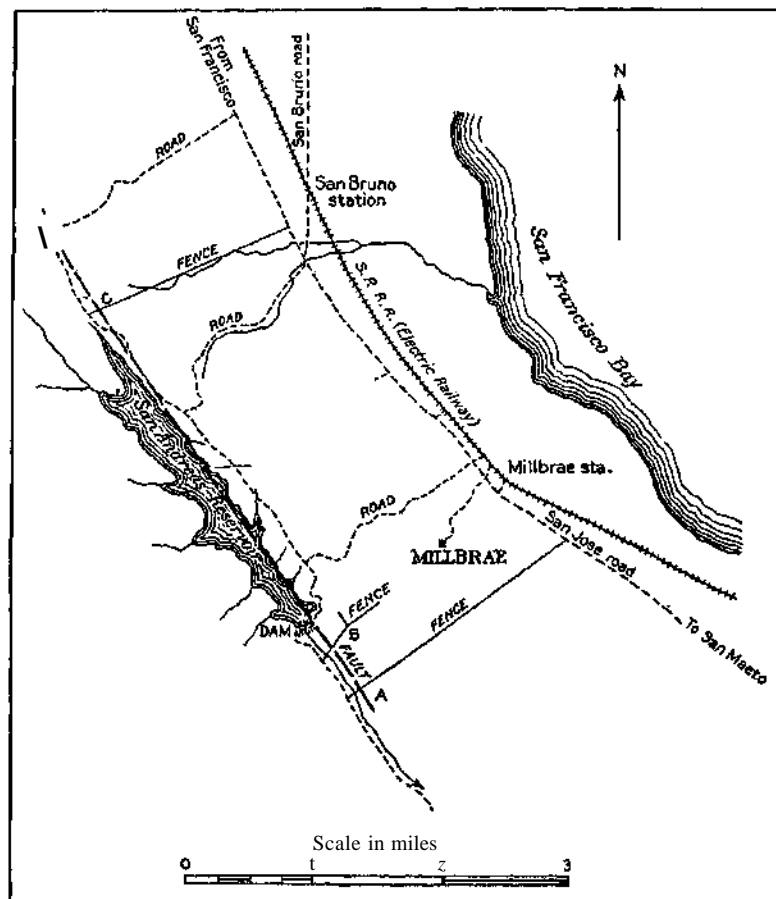

FIG. 30.—Index map showing positions of three fences, A, B, and C, the offsets of which are shown in figs. 31, 37, and 38.

About 2 miles from the upper end of San Andreas Lake the fault encounters the 30-inch, laminated, wrought-iron pipe of the Spring Valley Water Company, which prior to the earthquake conveyed the water from Pilarcitos Lake to San Francisco. The metal of the pipe is about 0.1875 inch thick and coated with asphaltum. The pipe is buried in the soil at a depth of 3 to 4 feet. The point of intersection is near Small Frawley Canyon. Here the course of the pipe swings from a northwesterly to a more northerly course, and the fault consequently intersects it at an acute angle. At the point of intersection, the pipe was obliquely sheared apart and telescoped upon itself, effecting a shortening of about 6 feet. The amount of the transverse offset involved in the shear was about half the diameter of the pipe. The portion north of the break was moved east and telescoped southerly. For 0.875 mile southeast of this point, the path of the fault lay on the northeast side of the pipe and nearly parallel to it, but a short distance away. About 220 yards southeast of the intersection, where the pipe, buried a few feet below the surface, ascends a rising slope, the pipe had completely collapsed for a distance of several

yards, due doubtless to the establishment of a partial vacuum within the pipe by the sudden withdrawal of the water from the arch in the pipe at the time of the shock, owing either to the leakage below, or the propulsion of the water induced by the shock. (See plate 60B.)

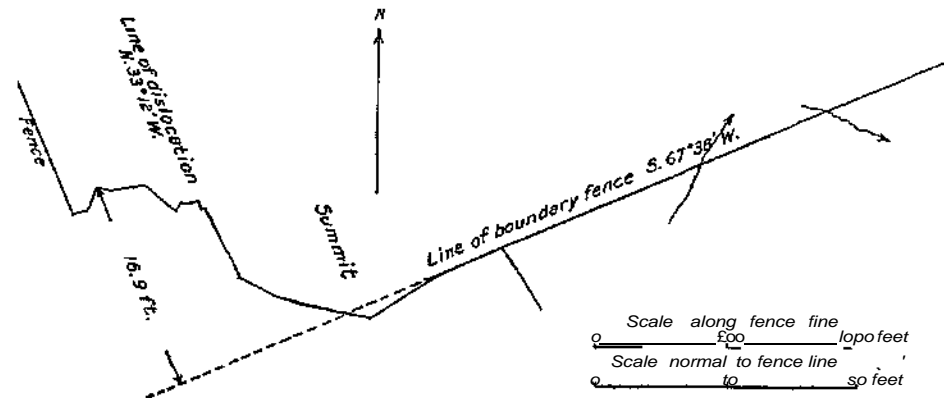

FIG. 31.—Fence C of fig. 30.

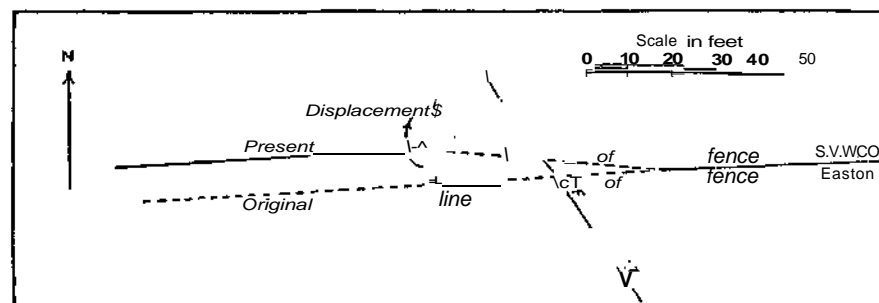

FIG. 32.—Dislocation of fence near San Andreas Lake. After H. Schiussler.

At a point about a mile from the upper end of San Andreas Lake, the fault intersects a bend in the pipe at two places, and here again the pipe was telescoped. (See plate 60A.) The conditions at one of these intersections are thus described by Mr. Robert Anderson:

The pipe makes an angle of about  $15^\circ$  with the fault-trace, the end of the pipe on the north side of the fault running that much nearer the north. The ends of the pipe on opposite sides of the fracture were therefore thrust into each other. The furrow was at this place divided into several smaller ones, the disturbed zone covering an area of considerable width. The pipe was broken in three places within 100 feet. In one place it was telescoped 58 inches, as shown in plate 59B; in another 17 inches, and in a third, the one farthest north, 41 inches.

Near the head of the lake, the pipe was again intersected by the fault, with results described by Mr. Anderson as follows:

The pipe line runs almost parallel with the fracture, but slightly more to the west at this point, so that the acute angles made by the ends of the pipe with the furrow were in this case on opposite sides of the furrow to those in the two previous instances. In other words, the southeast end of the pipe was farther to the east than the southeast end of the

furrow. The movement was in the same direction as before, therefore a pulling apart of the pipe took place instead of a compression. There occurred two breaks in the pipe (see plate 59A), the main one at the crossing of the fault, and the other 150 yards away on the northeast side of the fault, but very near it, the pipe being almost parallel with it. At the main break, the pipe was pulled apart 59 inches, and at the other one 21.5 inches, making a total displacement of 6.666 feet. The pipe was not quite parallel with the fault and therefore there was a slight offset, at right angles to its direction, of 4 inches at the main break and 2 inches at the minor one, or a total of 6 inches. A fence which crossed the fault at the main break is offset 6.5 feet. (Plate 60c.)

The index map, fig. 30 (p. 95), indicates the position of three dislocated fences which were surveyed by R. B. Symington, C.E. The fences are marked A, B, C. One of these fences, C, near the upper end of San Andreas Lake, is nearly normal to the trace of the fault, and its deformation extends over a zone 1,200 feet wide, the total displacement aggregating 16.9 feet. Here, as usual, the portion on the southwest side of the fault moved relatively to the northwest, but there was a distinct drag on the northeast side in the same direction. (See fig. 31.)

The offsets in three other fences southeast of San Andreas Lake are shown in figs. 32, 33, and 34 and plates 60D and 61B.

Thruout this 2-mile stretch within which the pipe line nearly parallels the fault-trace, the path of the latter is strongly marked by a prominent furrow in the sod, with the usual diagonal cracks and variable width. This furrow lies on the northeast side of the

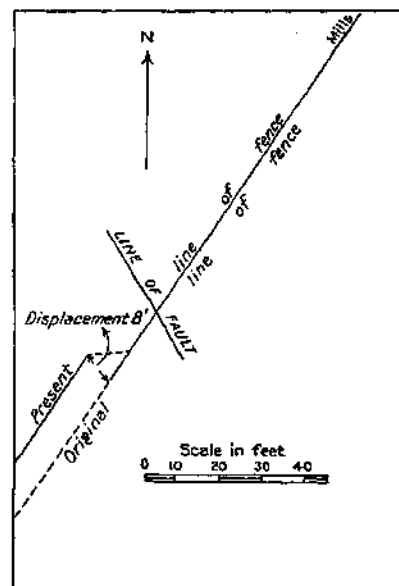

FIG. 33.—Dislocation of fence near San Andreas Lake. After H. Schussler.

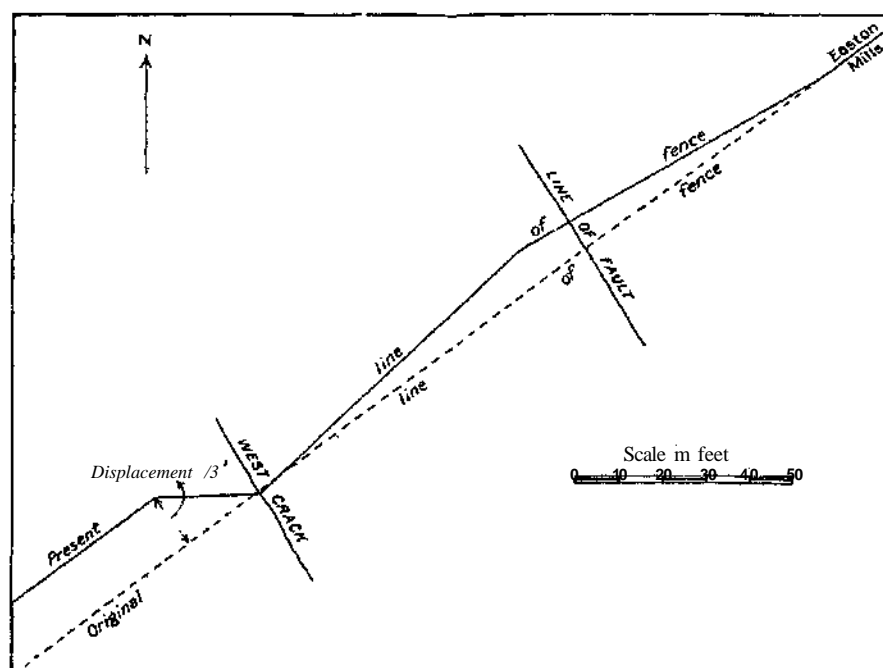

FIG. 34.—Dislocation of fence near San Andreas Lake. After H. Schussler.

lake for the first 0.875 of a mile of its length. It then enters the water (plate 61D) and follows the northeast side of the lake, a little distance from shore, to the San Andreas dam at the lower end of the lake. In this distance of nearly 2 miles, the fault-trace emerges from the water at a number of points where little capes project into the lake. The crossing of these capes by the fault-trace indicates that it follows a very straight course beneath the water of the lake. On the last of these promontories traversed by the fault, the main fault-trace has associated with it a number of auxiliary cracks. Between the main fault-trace and one of the diverging cracks, on the southwest side of the fault, is a brick and cement gate-well in connection with the tunnel which takes the waters from the lake toward Millbrae. This gate-well was circular in cross-section, the inside diameter being about 26 feet. The nearest point of the structure to the main fault-trace is within 5 feet.

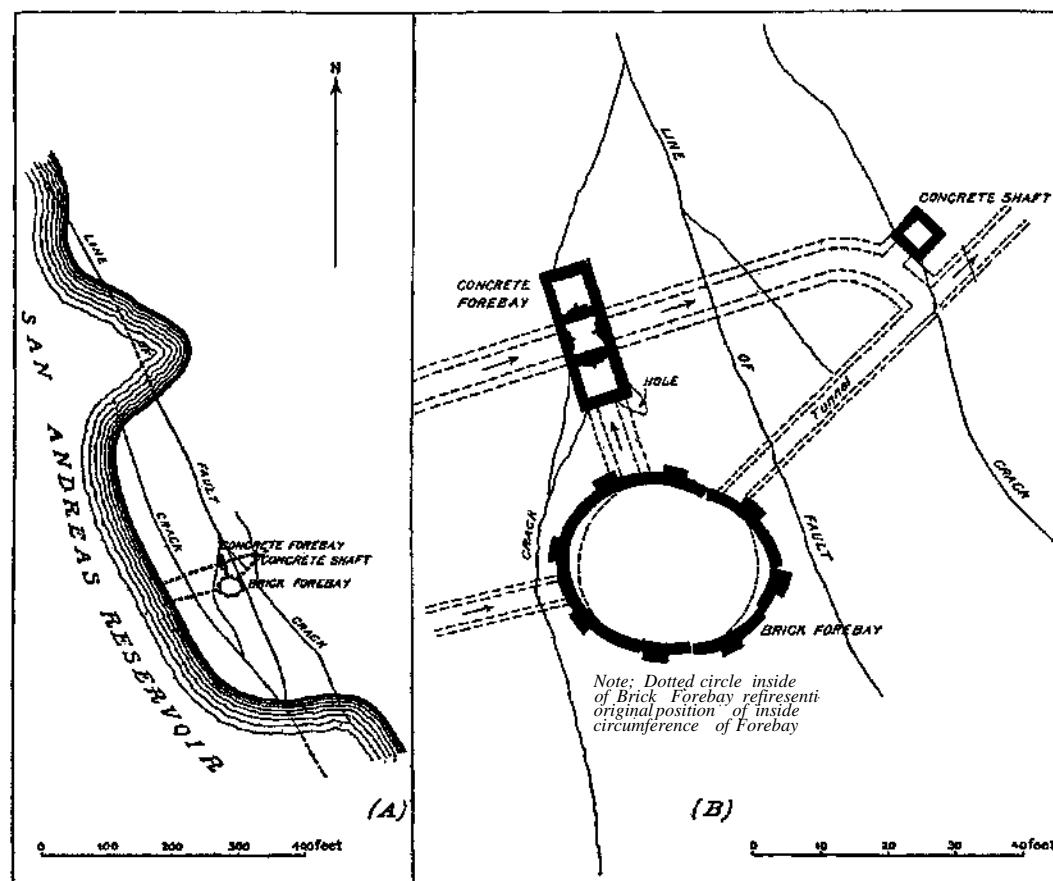

FIG. 35. — Main and auxiliary faults, San Andreas Lake. A. General Plan. B. Detail. After H. Schussier.

The walls are about a foot thick, and are strongly buttressed. As a result of the shock this gate-well was shattered and deformed so that it became oval in cross-section, the east and west diameter becoming 30 feet and the north and south diameter about 21 or 22 feet, as shown in the accompanying figure. A new concrete gate-well a few feet to the north, rectangular in cross-section and having three compartments, each 2.5 x 2.5 feet, was uninjured, altho on the line of the same branching crack. A concrete manhole 45 feet northeast of the damaged gate-well, also on an auxiliary crack, was similarly unaffected, (See fig. 35.)



At the San Andreas dam, the fault past through a rocky knoll which serves as an abutment for the dam on both sides, the embankment being in 2 parts. The rocks were shattered and the road over the dam and the fence paralleling it were offset several feet in the usual direction. The ground here was traversed by several cracks, those on the south-

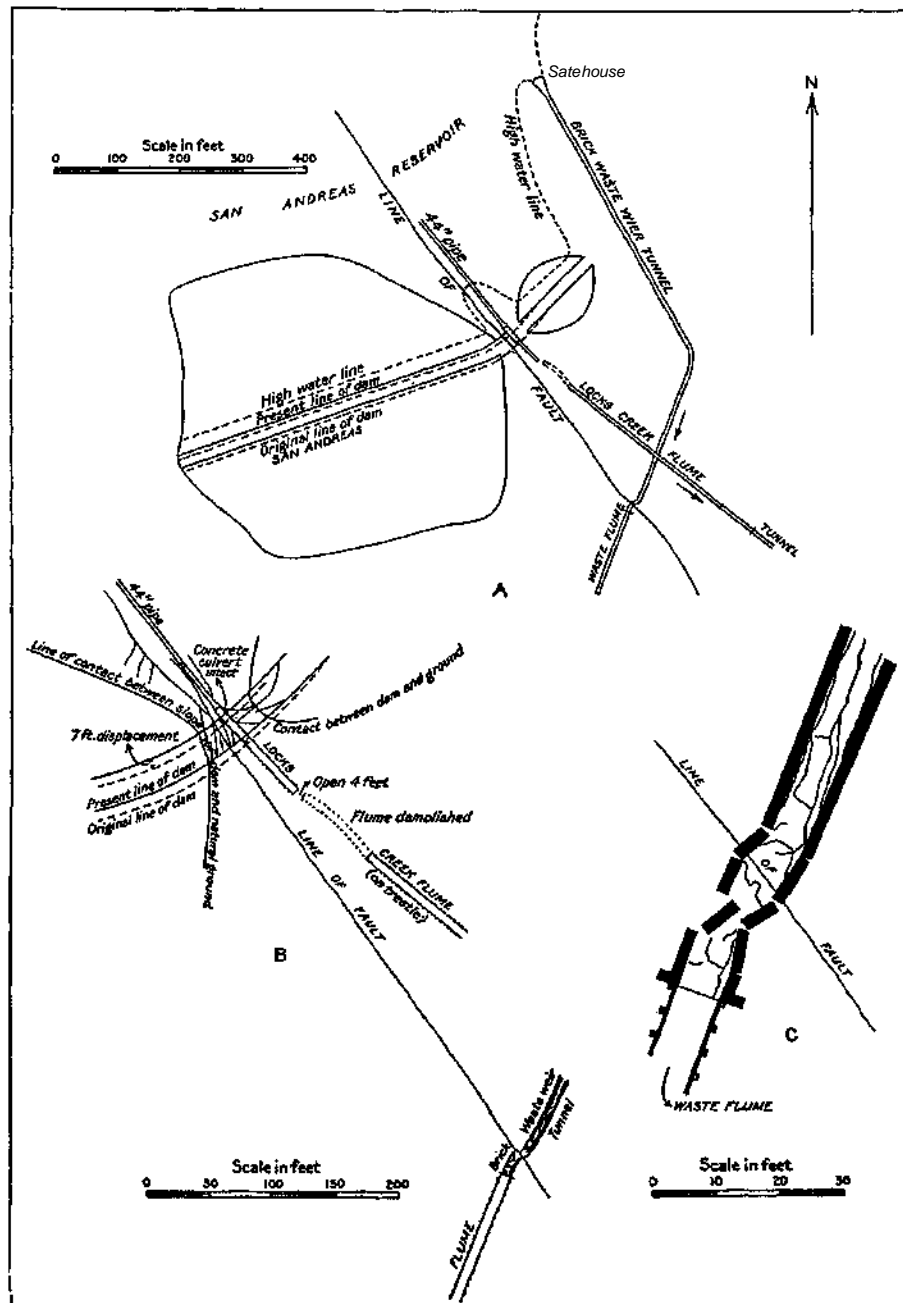

FIG. 3.— Intersection of San Andreas dam by fault. A. Plan of dam in two parts, with rock between. B. Relation of dam to waste weir tunnel. C. Detail of waste weir tunnel.

west side of the fault branching southerly from it and those on the northeast side branching northerly. Below the dam a heavy wooden flume on a trestle within 50 feet of the fault-trace was demolished for about 60 feet of its length.

About 125 yards below the dam the fault past thru the lower end of a massively built brick and cement waste weir tunnel. The inside diameter of the tunnel was about 7 or 8 feet and the walls were 17 inches thick. At the intersection of the fault within this structure, the latter was stove in and smashed in pieces for a distance of about 28 feet. The tunnel was offset about 5 feet. In the shattering of the brick work, the cracks and ruptures in no case followed the cement between the bricks, but broke across the latter; the cement and its adhesion to the bricks being stronger than the bricks themselves, altho the bricks were evidently carefully selected and of good quality. Several cracks traversed the tunnel longitudinally and obliquely to the northeast of the part that was demolished. (See fig. 36.)

About 550 yards below the San Andreas dam, the fault-trace crost a boundary fence

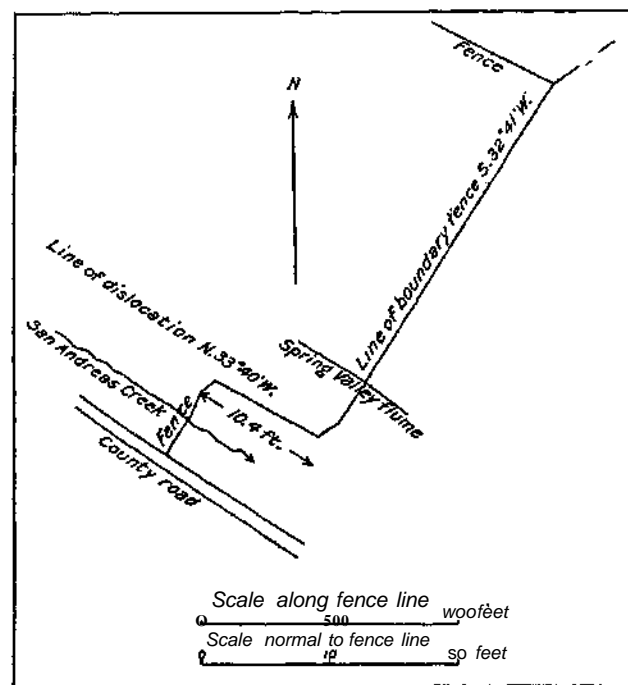

FIG. 37.—Fence B of fig. 30. Dislocated by fault.

between the estate of D. O. Mills and the property of the Spring Valley Water Company, causing an offset of about 10 feet. Here the deformation of the fence was distributed over a zone 300 feet wide in the direction of the fence, or about 250 feet in a direction normal to the trace of the fault. A survey of the dislocated fence made by R. B. Symington, C.E., is shown in fig. 37. Half a mile below the dam, the fault again crost the Pilarcitos pipe. A note by Mr. Anderson as to the conditions at this intersection is as follows :

It is a 2-foot pipe made of iron 1 inch thick. The fault broke it at an upward bend. An elbow at the bend was crushed by the compression and thrown down, while the two remaining ends were brought about 22 inches nearer together. At the same time they were faulted past each other a distance of 20 inches.

The pipe runs N. 25° E., making an angle of 65° with the fracture, which here runs N. 40° W. The telescoping at this angle, being 22 inches, represents 52 inches of faulting.

In this neighborhood the fault crost a wire fence nearly normally, the line of which had been carefully established by a series of stone monuments. The fence marks the boundary between the estates of D. O. Mills and A. M. Easton. The deformation of the fence as shown in the accompanying diagram, fig. 38, from a survey by R. B. Symington, C.E., extended over a zone at least 2,200 feet wide. On the southwest side of the fault-trace, the fence was displaced to the northwest a distance of 9.3 feet, and on the northeast side it was displaced to the southeast 3.4 feet, making a total displacement of 12.7 feet and showing a slight drag close to the line of the fault. There were two parallel cracks representing the fault about 90 feet apart, and the chief displacement took place on the west crack.

About 0.625 mile farther southeast, near the upper end of Crystal Springs Lake, the fault crost another fence showing a displacement of 9 feet. About 0.25 mile southeast of this place, the fault crost the Locks Creek 44-inch pipe line. Regarding this intersection Mr. Anderson writes:



A. Rupture of 30-inch water-pipe by fault. Northwest of San Andreas Lake, A. O. L.



B. Break of 30-inch water-pipe by fault, northwest of San Andreas Lake. Annotated by the author, 1958. A. O. L.

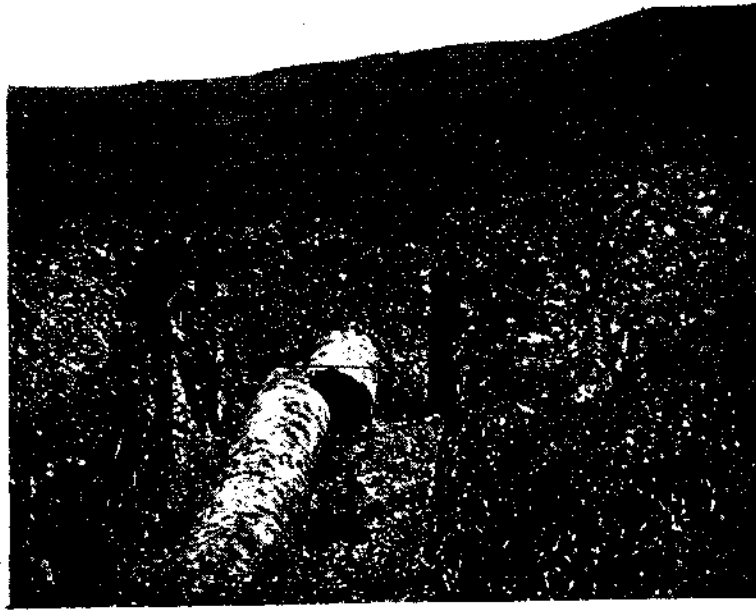

A. Offset in 30-inch water-pipe by fault. Northwest of San Andreas Lake. E. L. H.



B. Collapse of 30-inch water-pipe northwest of San Andreas Lake. E. L. H.

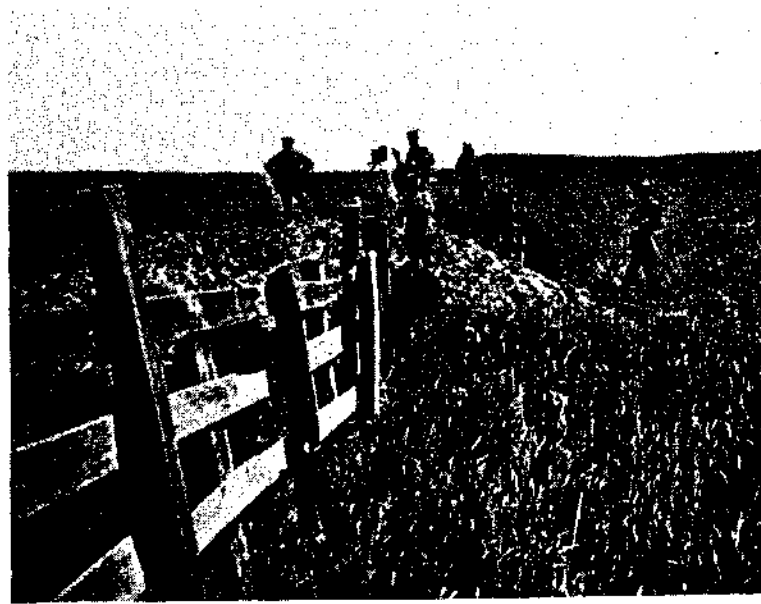

C. Offset of 6.5 feet in fence, northwest of San Andreas Lake. E. L. H.



D. Offset of 6 feet in fence between San Andreas and Crystal Springs Lakes. Per J. O.B.



A. Fault-trace where it passes into San Andieas Lake, D.



B, Ofikrtfitto\*WMurGj!V7-:jfsLO». B. A.



A. Exposure of slickensided fault plane near north end of Crystal Springs Lake, E. A.



B. Offset of road by main fault near Seartrille reservoir. Per J. C. B.



southeast, it crosses a small point projecting into the lake from the northeast side. Half a mile beyond it passes thru the dam between Upper and Lower Crystal Springs Lakes. This dam is now simply a causeway across the lake, the water on both sides standing at the same level. The dam was rendered superfluous except as a causeway by the construction of the great concrete dam at the outlet of the present Lower Crystal Springs Lake. The latter was uninjured by the earthquake, a careful examination having failed to reveal even a crack in the splendid structure.

Where the fault intersects the causeway dam between Upper and Lower Crystal Springs Lakes, the dam was dislocated and offset about 8 feet. (Fig. 40.) This displacement was well marked in the roadway across the dam and in the fences which parallel it. The fences on both sides of the road were broken and the boards were buckled and shoved over each other; the telephone wires crossing the lake sagged considerably, showing that the movement brought the poles closer together. The facts indicate, as previously stated, that, in addition to the offset of the dam along the line of the fault, there was a notable compression in the direction normal to it. Beyond this dam the trace of the fault is partly beneath the lake and partly skirts its southwest shore (for the water level of April, 1906), and finally leaves the lake on that side about 0.25 mile from its southeast end.

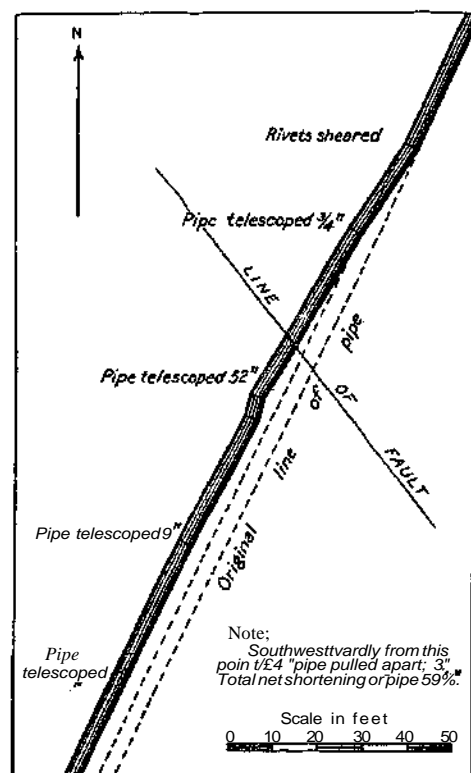

FIG. 39.—Intersection of fault and Locks Creek pipe. After H. Schussler.

relatively, leaving a portion of its lower slope in juxtaposition with the higher slope of the other side. A horizontal line across the exposed face would give the distance moved, provided no subsidence had taken place, which does not seem to have been the case. The distance could be only approximately measured, but it is at least 8 or 10 feet. A crack 2 to 3 feet wide and several feet deep separates the two walls locally. Looking at the oilier side of the same mound an irregular face several feet in height is exposed on the northeast side of the fault, the natural result of a longitudinal slipping. The faulting of raised surfaces after this fashion was discovered in various other instances. Large hills were crost only two or three times in this stretch of the fault. They were not so affected.

The banks of stream channels sometimes preserved evidence of the movement even more completely than did mounds. Almost every gully crost by the fracture suffered

*Exposures of the fault-plane* (R. Anderson). — In addition to the evidence given by fences and pipes, there is the displacement of land surfaces and actual exposures of the fault face at the surface. Examination of mounds, embankments, and shore lines crost by the rupture usually revealed a displacement of the surface, and an interruption of the old topographic outlines. In the case of mounds cut by the fracture, the displacement makes itself apparent in vertical scarps in consequence of the curved surfaces being faulted past each other. At the northwest face of a hillock, near where the furrow emerges from Crystal Springs Lake, the northeast side of the mound—the side away from the lake—has retreated



a disjuncting, resulting in a narrowing and bending of the channel at one point. The banks on the northeast and southwest sides of the fault were thrust past each other southeast and northwest, respectively. Usually the movement resulted in the crushing of the loose earth at the surface, while the roots of plants tended to hold it in place, so that the displacement was not evident in its full effect. An example where this is well shown occurs in the channel of a small stream running at right angles to the fault valley just north of the north end of Crystal Springs Lake. The banks of the gully were about 20 feet high. Where the fault crosses the southeast bank, the parts on either side of the crack faulted past each other horizontally, the result being a relative displacement of the northeast side of the fracture at least 8 feet toward the southeast. There is no vertical movement apparent. An escarpment is left exposed on the southwest side of the fault from top to bottom of the embankment. The material of the bank, plastic, argillaceous earth derived from weathered shale, was slightly moist at the time. The fault planes are closely apprest and the clay was left slicken-sided and lined with distinct horizontal striations. (Plate 62A.) The opposite bank of the stream gives evidence of a similar movement, but the loose earth was held by large roots and the displacement of the underlying earth was obscured. The two projecting faces of the opposite banks almost met, making the channel very narrow and curved.<sup>1</sup>

A steep embankment of weathered serpentine and soil occurs at the southern end of San Andreas Lake, where it is crossed by the fault. The zone of rupture is several feet in width and the broken material on the northeast side is shown projecting several feet beyond its previous position in continuity with the serpentine slope. A displacement of the shore line is observable at several places where the fault fissure enters the lake. Wherever cracks were opened, search was made for the disjuncting of squirrel holes and other discrepancies due to shifting, but with rather unsatisfactory results. Roots, however, were found broken and displaced in accordance with the general movement as shown by other things. In general, the search for evidence in the separation of different zones of vegetation or of color in the earth, etc., failed to add anything of value to evidences of other kinds.

*Vertical movement* (R. Anderson). — No proof was found of a vertical movement along the fault line. Here and there occur small escarpments along the fissures, varying from a few inches to several feet in height. They were only local, however; they exhibited no constancy in the side of the fault upon which they appeared, and were invariably explainable either as fault exposuras such as are discussed in the previous paragraphs, or as

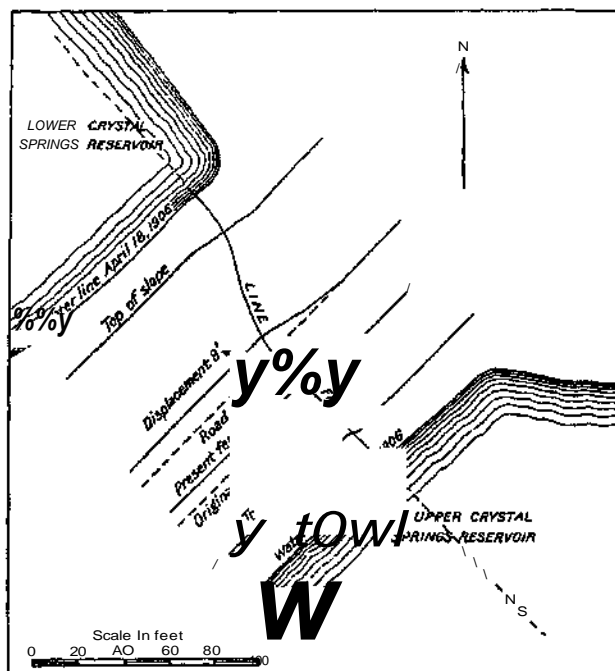

FIG. 40. — Map of fault-trace across old dam between Upper and Lower Crystal Springs Lakes. After H. Schussler.

<sup>1</sup> The writer is indebted to Mr. C. E. Durrell and Mr. F. D. Posey, of St. Matthews School, San Mateo, for the discovery of this interesting example of faulting.

due to settling of loosely accumulated or unsupported earth. For this reason no credence is given to the idea that an uplift or downthrow occurred along this part of the fault. This statement is based entirely on the evidence collected on the ground shortly after the earthquake and has nothing to do with the direction or amount of earlier displacement along this same fault-line. In some places an upward thrust seems to have taken place, as in the case of raising 7 pipes. This may, however, have been caused by wave-like movement in the ground near the surface or simply by the local heaving up of the ground as the result of compression.

#### CRYSTAL SPRINGS LAZE TO CONGRESS SPRINGS.

For our knowledge of the character and extent of the earth's movement on the fault for that portion of its course lying within the limits of the Santa Cruz quadrangle of the U. S. Geological Survey, or between Crystal Springs Lake and the vicinity of Congress Springs, we are indebted to observations made by Messrs. H. P. Gage, F. Lane, S. Taber, and B. Bryan, under the direction of Professor J. C. Branner. The notes of these gentlemen are preceded by a summary statement, and are arranged as far as possible in sequence from northwest to southeast in the following section:

*Summary statement* (J. C. Branner). — The fault-trace that follows the San Andreas Valley continues southeastward in a nearly straight line. Beyond Crystal Springs Lake, it passes thru the village of Woodside, the Portola Valley, crosses Black Mountain a mile southwest of the triangulation station, follows down the general course of Stevens Creek a distance of 5 miles, and thence, following the same general direction along the eastern slope of Castle Rock Ridge, passes off the eastern side of the Santa Cruz quadrangle near latitude  $37^{\circ} 10'$ . West of Stanford University it follows along the northeastern base of the mountains that lie between the Pacific Ocean and the Bay of San Francisco, but as it passes toward the southeast, it cuts into the range and leaves Black Mountain and Monte Bello Ridge on the northeast side, while south of Saratoga it keeps well within the mountains. A singular feature of the fault, as it appears at the surface, is that instead of following the bottoms of the valleys, it often skirts along the base of one of the enclosing ridges, as shown in the accompanying sections. (Fig. 41.) This is not an invariable rule, however.

It will be seen from the map/No. 22, of the isoseismal lines on the Santa Cruz quadrangle that there are several other faults within the area of the quadrangle, but evidences of movement at the time of the earthquake have been found only on this San Andreas fault-line, with the possible exception of slight movements along part of the Black Mountain fault. Cracks in the ground occur here and there almost all over the area covered by the sheet, but the cracks away from the San Andreas fault are due to incipient landslides or to the settling of loose or wet ground, and are not otherwise related to the more profound faults.

The movement that took place along the fault in this portion of its course at the time of the earthquake was almost entirely a horizontal one. At several places evidences were seen of vertical displacement, but further examination showed in many instances that the appearances were deceptive or due to local causes. For example, where the fault crosses the top of Black Mountain there was apparently an upthrust on the northeast side of the fault. But it was found later that a great wedge-shaped piece nearly half a mile across had settled on the southwest side of the fault, producing this appearance.

The direction of the horizontal displacement is uniformly a relative southeastward movement of the land on the northeast side of the fault. The amount of displacement varies in this area from near zero to 8.5 feet. This variation appears to be due to the character and condition of the ground. Usually ground that was wet and incoherent at

the time of the rupture yielded and was crushed so as to distribute the displacement through the surrounding soil. In such places, but little or no horizontal thrust appeared at the surface. Where the land was well drained and the surface materials were dry, the ground held together better except along the fracture itself, and the displacement was more apparent. It seems highly probable, however, that, owing to the deep decomposition of the rocks and the frequent movements and fractured condition of the beds along the fault, the maximum displacement does not appear at the surface anywhere within the area of the Santa Cruz quadrangle. Nowhere has the fracture been found passing through freshly broken beds; and in view of the antiquity of the fault itself, and the evidence of many movements upon it, such an exposure is not to be expected.

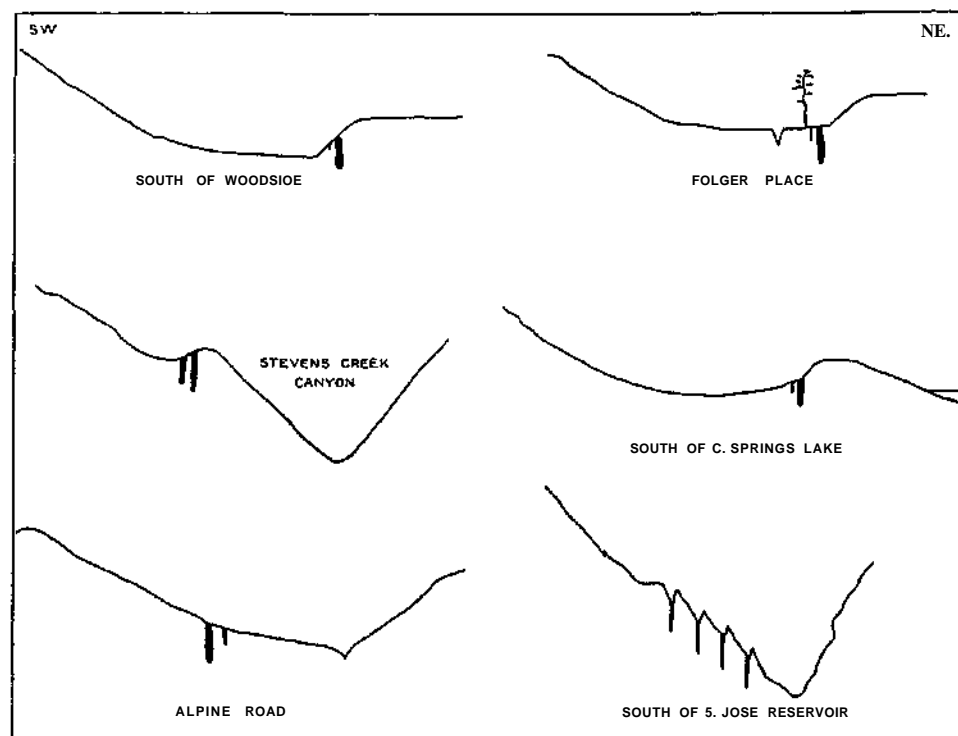

FIG. 41. —Profiles of Rift, showing relation of fault to slopes.

*Crystal Springs Lake to Portola.* — Southeast of the southern end of Crystal Springs Lake are numerous cracks along the line of the fault. One less than 0.5 mile from the southern end of the lake past directly under a house, the chimney of which had fallen, and the building had burned to the ground. (28, map 22.) About 100 feet southeast of the road near this house (29, map 22) a crack 1.5 feet wide in places runs approximately parallel to the road. The cracked belt adjoining is about 4 feet in width, the downthrow being about 6 inches on the northeast side, the lateral thrust about 1 foot on the same side, the northeast side moving southeast relative to the opposite side.

About a mile southeast of the lake are large cracks, running approximately north and south, in places 1.5 feet wide. At a point 2 miles southeast of the lake, a crack about a foot wide is crossed by a fence running N. 53° W. (27, map 22.) The top wire of this fence was broken by tension during the shock, and the post nearest the crack was snapped off at the ground, the adjoining post being uprooted, and bent over in the same direction as the broken one. The posts are of split wood about 5 inches in diameter, and the wires

are 2-strand barbed wire. This belt of cracks continues for about 300 yards along the road. Near Woodside there was a 2-inch crack trending northwest-southeast, with an upthrust of about 2 inches on the northeast side. A crack 1.5 feet wide in places runs N. 23° W. across the road, entering Woodside village from the southwest, just west of the bridge, and in places shows an upthrust of about 2 feet on the northeast side. A small tree on this crack was uprooted in the western part of the village. On the King's Mountain road, southeast of Woodside, a large crack of the main fault-trace crossed the road, and the fences on both sides were pulled apart. (See plate 62B.) NO vertical throw was observable. About 200 feet west of the fault fracture were several smaller cracks parallel to it.

Further southeast, down the road toward Portola, the main fault-trace crosses the road just north of the creek and within 12 feet of a giant redwood. The ground was raised and crumpled across the road, and the cracks extend both up and down the stream from this place. In a cluster of young redwoods southeast of this road a board fence is bent out of line, and huge cracks opened among the roots of the trees. A wire fence was pulled in two and one of the posts split. In this cluster of trees the fault passed thru and split a big redwood stump.

Two fences crossing the crack at right angles near 12 (map 22) had been thrown out of line, their northeast portions being moved southeast relative to their southwest portions. They had been given an offset of 8.5 and 8 feet respectively. (Plate 63B.) A large oak tree standing on the crack was uprooted, while branches were snapped on a big white oak tree just south of the fault line.

Northwest of Searsville Lake, about a mile, there is a belt of cracked ground 7 or 8 feet wide, one crack being 1 foot in width. The apparent upthrust was in some places 2 feet on the northeast side. At other places there is no change of level. On the Portola road, just southwest of the Searsville Lake, parallel cracks with a trend N. 43° W., some of them 1.5 feet wide, were formed across the road and extended into the marsh to the northwest and into the woods on the southeast. Where they crossed the road, the fence boards were broken and the earth shoved up in ridges; the northeast side of the crack moved southeastward.

The main fault fracture passes thru the Portola Valley and crosses the public road in front of a small 1-story house southeast of the village store. Where the fault crosses the road, the fences on both sides were torn in two, and in the prune orchard south of the road the rows of trees were displaced in some instances about 2 feet. The cracks in the road were about 6 inches wide, approximately parallel, and running nearly north-south, while the direction of the fault line itself was about northwest-southeast.

About a mile beyond Portola, a crack, measuring 2.5 feet in width in some places, crossed a field, the cracked ground spreading out for 10 feet at intervals. Wooden fences crossing it were broken, water pipes bent and pushed up to the surface of the ground, and a dead tree near the line of the crack was thrown down. There was an apparent upthrust of about 2 feet on its northeast side.

*Road from Judge Allen's southward.* — Between 3 and 4 miles southeast of Portola, many cracks were visible extending in all directions. Several showed an uplift on the east or northeast side, which is also the downhill side. Some cracks were from 4 to 5 inches wide, and had a vertical throw of nearly a foot. In other places the downhill side had been thrust upward, and pieces of the crust shoved as much as 4 inches over the uphill side. Near the top of the ridge, just before reaching the point where the trail branches off, a 4-inch crack running S. 63° E. showed a 4-inch upthrow on the northeast (downhill) side. Southwest of the ridge and about 100 feet below the trail, an old landslide dating back to some time within the past year, covers about 2 acres. Around this slide the ground appeared to have been much cracked recently.

Along this trail the direction of the cracks varied considerably. One an inch wide in places, elsewhere branching into several smaller ones, was traced for about 150 yards, chiefly along the crest of the ridge. Its direction varied from due east to southeast, and the upthrust on the west was sometimes as much as 3 feet. Going northwest down the crest of the ridge, numerous cracks crossed in directions varying from southeast-northwest to northeast-southwest, several showing an upthrust varying from a few inches to a foot on the southwest side. At the foot of the trail, a large crack running down the center of the valley followed the road for about 100 yards, then cut across the fields. In places the crack was 2 feet wide, but in other places a ridge 3 feet high had been raised beside the road, and there were many parallel cracks within 50 feet of either side. There were upthrusts and downthrows, some as much as 1.5 feet, but the total change of level seemed to be nil.

*Alpine road.* — A fault branches from the main San Andreas fault in the Portola Valley and crosses the Alpine road just where the Portola road leaves the latter. At this fork several cracks were formed at the time of the earthquake. A water pipe 2 inches in diameter was buckled and lifted out of the ground here, and farther along the Portola road this same pipe was pulled apart. Following southward along the Alpine road, the next evidence of disturbance by the earthquake was where the main fault-trace crosses the road 0.75 mile south of where the Portola road forks. Here the road was so badly broken and cracked that it was not possible to ride or drive across the fracture until the place was repaired. (Plate 63A.) The fracture followed along the south side of the road for a distance of 300 feet, tearing up the bank with cracks, some of which were a foot or more across. Where the road bends toward the south, the fracture crossed to the north side of the road, making cavities several feet deep. These cracks continued toward the northwest thru the underbrush, pulling apart a barbed wire fence and leaving many well-marked furrows thru the adjoining fields. About 30 feet north of the road, a white oak, somewhat weakened by decay and fire, was jerked off by the violence of the shock. To the southeast the fault-line is traceable by a well-marked furrow thrown up in the fields. Where the fracture crosses the Alpine road, there appears to have been an uplift of about 2 feet on the northeast side of the fault. This appearance may be due to the settling of a part of the ridge of incoherent materials to the south, or it may be due to the lateral thrust along a sloping surface.

*Black Mountain.* — The great mass of Black Mountain lies between the San Andreas fault and a branch fault (Black Mountain fault) which, starting in the Portola Valley, crosses the Page Mill road on the north side of the mountain about a mile south of Clarita vineyard. This area between the faults was badly shattered by the earthquake, tho it is not clear whether the abundant cracks found over the surface are to be attributed to the boldness of the topography or to the crushing of the wedge-shaped end of the fault block. Several days after the earthquake, 345 cracks, large and small, were counted along the county road (Page Mill) in a distance of less than 3 miles between these faults. These cracks ran in every direction, and some of them were clearly attributable to local topography, while others cut thru the mountains in apparent disregard of the topography.

The main fault-trace crosses the Page Mill road in a topographic saddle near three frame houses. The displacement occurred along two parallel and well-defined cracks some 30 feet apart. These cracks can be traced across the fields on both sides of the road. Toward the northwest they converge until they are only a few feet apart. Where they cross the road, the fracture was not a single clean-cut break, but made up of a series of small short cracks from 3 to 5 inches across, parallel with each other and "splintering" across the general direction of the fracture. The fences on both sides of the road were displaced about 3 feet, and there was an apparent drop of 18 inches on the southwest side of the fault. The horizontal displacement showed the northeast side to have moved

relatively toward the southeast. The apparent vertical displacement seems to be deceptive, or rather, it appears to be due to the settling of a wedge-shaped mass on the southwest side of the fault. The south side of this mass was indicated by a crack about 300 yards farther south along the road where a crack showed a drop of several inches on the northeast side. On the Monte Bello Ridge, a mile southeast of the Black Mountain triangulation station, there were a few inconspicuous cracks, without any uniformity of direction. Just south of the triangulation station, the cracks were more conspicuous; one of them was 200 feet long, and had a bearing of N. 13° W. At and about Hidden Villa, a small ranch in the deep valley 2 miles northwest of Black Mountain triangulation station, there were no cracks in the low ground, even where they were expected, as this is on the line of the Black Mountain fault that crosses this region from the direction of Portola.

*Page Mill road.* — In following the Page Mill road up Corde Madera Creek from Mayfield, the first noticeable trace of the earthquake was a crack crossing the road due east and west, its width varying from 0.5 to 1 inch. Wagon-tracks showed a lateral displacement of 1 inch, the north side of the crack having moved west, relatively to its south side. This crack was traced a short distance into the fields beside the road, where it disappeared. Several smaller cross-cracks intersected it at intervals. There was no apparent vertical displacement. About 100 yards farther south were 3 smaller cracks varying from 0.25 to 0.75 inch in width. One ran N. 53° W., and another N. 23° W. The latter, being only 8 feet from a culvert crossing under the road, appears to have been deflected by this from a course running more nearly east. Here again was no evidence of vertical throw. Going on up toward the Alpine road from this point, more and more cracks were found, running approximately east and west, with the exception of several north and south ones where the road ran closely parallel to the stream. Less than a mile from the first crack, groups of cracks were accompanied by small slides of dirt from the hill to the west of the road, and farther on from the bluff to the east of it. The cracks ran nearly parallel with the axis of the branch-valley lying northeast and southwest. Farther up the road, large cracks began to appear among smaller ones running parallel. The first of these was 2.5 inches across and ran S. 13° E., with a downthrow of 1 inch on the east side, and could be traced from 50 to 100 feet on either side of the road. For a mile farther up the road, the cracks became so numerous and complicated that it was impossible to map any individual ones. They intersected and ran in all directions, and were all of varying widths, the largest seen measuring 8 inches across. The size of this crack, however, was probably partly due to its position on the side of a hill. The larger cracks could be traced for several hundred feet. In some places crushing had taken place, and the layer of macadam on the road had been humped up and broken. In this same area are many small landslides, some large enough to cover the road; one has occurred since the earthquake.

*Stevens Creek.* — Following the road from the junction of the Castle Rock Ridge road with the road from Stevens Creek to Boulder Creek toward Stevens Creek, small cracks appeared crossing the road in a direction of N. 1° E. Further east nearer Stevens Creek, the road was badly broken up by the land sliding in two directions, N. 18° W. and N. 47° E. All along this region cracks varying from a fraction of an inch to 2 inches in width, and running from N. 43° W. to due north and south, appear every 10 feet or more, showing a badly broken-up area. Here and there such cracks resulted in landslides from the bank to the road. A crack about 2 inches wide ran N. 53° W. for some distance above the house, at the junction with the Stevens Creek road. On the Stevens Creek road, just after leaving the Saratoga road, there were cracks every 20 or 30 feet, running in the same direction, about N. 43° W. A mile and a half northwest of the place where Stevens Creek turns northeast, a strip of ground 2 feet in width and about 100 yards long had been broken up, with a downthrow of about 6 inches on the west side. The cracks ran N.



A. Offset of Alpine road 5 miles west of Staaford University. Per J. O. B.



B. Offset of Alpine road 5 miles west of Staaford University. Per J. G. B.

43° W. From here northwest the disturbance continues in the same general direction. A number of breaks often occurred together, arranged as steps, in each case the downthrow being on the east side and measuring about 4 inches, the direction varying from N. 33° W. to N. 3° W. Following the Stevens Creek road on down toward Congress Springs, several landslides were noted, mostly small ones due to caving in of the banks of the creek. Just west of the springs the road was badly broken, twisted, and shoved up in places, the downthrow being first on one side and then on the other. In some places along the bank the west side projected 2 inches farther than the other, while the fence showed an offset of 2 feet. The large stone bridge across the creek appeared intact, but west of it a large patch of ground had slipped down 2 feet.

*South of Congress Springs.* — Near and northwest of the reservoir 2.5 miles southeast of Congress Springs, fissures from 4 to 6 feet wide ran nearly north and south, and past thru the earthen dam at the northwest end of the reservoir. (Plate 64A.) The intake pipes at the south end of the reservoir were disconnected, and the escaping water undermined a part of the southern dam of the reservoir. This reservoir is in a topographic saddle and has dams at both ends. The fault-trace passes thru this saddle. Where the bottom of the reservoir was exposed by the escape of the water, cracks of the fault-trace were exposed in the mud. Fences crossing the fissures showed but little displacement; the displacement moved the northeast side toward the southeast, relatively. The hills southeast of the reservoir have steep slopes of from 20 to 50 degrees. The cracks follow the east-facing slopes and the east side of these cracks had raised about 6 or 8 inches. Southeast of the reservoir the chimneys and water-tanks were down.

#### CONGRESS SPRINGS TO SAN JUAN.

Mr. G. A. Waring, under the direction of Prof. J. C. Branner, studied the displacement along the fault from the vicinity of Congress Springs to its southern end near San Juan. The following is an account of the phenomena observed by him:

*Cracks and displacements along the fault-trace* (G. A. Waring). — Starting at the upper reservoir about 2 miles south of Congress Springs, the fault-trace was followed to its southern end near San Juan. From the upper reservoir, thru which the fault passes, craking the dams at each end, a fairly continuous series of cracks a few inches wide runs down the southwest side of Lyndon Creek about 2 miles to Mr. Edwards' place, "Glendora." Thruout this distance the individual cracks run S. 3° to 13° E., while the line as a whole trends S. 33° E. The relative movement of the northeast side of the fault is from 14 to 20 inches southeast. From Glendora the fractured zone becomes wider and not so distinct. The lower reservoir is slightly cracked and several fissures appear near it, but the main line of fracture seems to be nearly 0.5 mile west of it, showing in two or three cultivated fields. The whole ridge west of the reservoirs was severely shaken, however, for cracks 4 or 5 inches wide opened near Grizzly Rock and several large slides occurred in its neighborhood. One water-pipe running north and south on the Beatty place was broken, while one trending east and west was unhurt. No cracks were found crossing the ridge between Grizzly Rock and White Rock. The cracks were next found on the road about a mile east of B. M. 2135 of the U. S. Geological Survey, but they do not show in the vineyard to the southeast. On the ridge road, about 5 miles northwest of Wright Station, the fault again shows slightly in a few 2-inch cracks bearing S. 3° E., with a slight relative movement of the east side toward the north. Going down the slope from here to Wright, the cracks rapidly become larger.

At Patchin, 3 miles west of Wright Station, there are fissures over a foot wide trending mainly in the direct line of the fault (S. 33° E.). Several stretches of numerous small



cracks alternating with a few long, continuous fissures, mark the course from Patchin to Wright Station. Thru the Morrell ranch it is especially evident. (See plate 64B.) At Wright Station the movement is well shown in the railway tunnel. (Fig. 42.) This tunnel runs southwest, and about 400 feet in from the eastern end of it there is a nearly vertical slicken-sided plane, showing a shear movement of 5 feet. Apparently the southwest side moved northwestward. Between Wright and Alma, the railway track was badly bent in places (see plate 107A), but the ground did not crack noticeably. It seems to have been subjected to compression, for 7 inches had to be cut from the rails when the track was repaired. A large landslide also occurred close to Wright Station, partly damming up the stream. The fault past a little west of Wright, tearing up the public road at several places (plate 65A), especially at the blacksmith shop, near Burrell Schoolhouse. Sulfurous fumes are said to have risen from this crack for several hours. From this place the cracks run up over the ridge just west of Skyland. Large fissures show in the orchards and fields on the eastern side of the ridge, but are not so evident on the western slope. Here, instead, great landslides occurred, and redwoods were snapped off or uprooted. Thru the timbered region from Skyland to Aptos Creek, the course of the fault-trace is marked almost its entire length by a swath of felled trees, true fault fissures being found at only two places. On the northern side of Bridge Creek Canyon there are typical cracks from 1 to 8 inches wide, and here also occurred a great landslide which buried the Loma Prieta Mill. The second place where fault fractures are found is on the ridge between Bridge and Aptos Creeks, where there are well-defined fissures up to 18 inches in width, trending S. 3° E., with a downthrow of the western (upper) side of from 2 to 6 feet, and a relative movement of the east side a few inches toward the south. The cracked zone is about 50 feet wide. Great slides on both sides of Aptos Creek have almost made a valley of the canyon for fully 0.75 mile. Following across the ridges and canyons, the discontinuous line of slides and sinks in upland marshy places marks the course of the fault-line down into the lowland.

The road at Corralitos is said to have been slightly cracked, and in the low hills between Valencia and Corralitos a few cracks were found; but the fault evidently runs fully 0.5 mile east of Corralitos. The mountain roads east and northeast of Corralitos were rendered impassable by landslides and by the bridges being injured. Crossing the road near Hazel Dell Creek is a band of small cracks 35 yards wide, trending S. 3° E. The fence on either side is not displaced, but the posts lean 30° to the southwest. About 0.25 mile farther northeast the stake fence on the northwestern side of the road is moved 10 inches out of line, and the ground just beyond has sunk a few inches. The fissures appear to die out in the marshy land west of Wm. McGrath's house, and they begin again a mile eastward, halfway up the slope. Thru this upland meadow region is a series of slides and sinks gradually rising in elevation. At a small ravine, fissures again appear and follow up it (S. 33° E.) for 0.25 mile, mainly as a great furrow from 2 to 6 feet wide. Three ponds near the divide lie directly in its path, but the cracks are only a few inches wide here. Thru the grain fields beyond they are not very evident until at the divide between the steep slope to the Pajaro River and the gentle westward drainage. Several cracks a foot or less in width show on the ridge, but the fault seems to set off about 100 yards to the northeast and to consist of east and west cracks, having loosened the whole slope for nearly a mile northward of Chittenden, causing great landslides. The fault-line crosses the Pajaro River at the railway bridge at Chittenden. The movement is shown by the disturbance of the concrete bridge piers. (See plates 17A, 65B, and fig. 43.) Thence straight across the low hills and fields on the opposite side of the river a line of cracks extends, passing 0.5 mile west of Mr. Canfield's house, "just where the earth cracked 16 years ago." This crack crosses the Sargent-San Jose road a mile north of San Juan,



A. Reservoir in saddle south of Saratoga traversed by main fault, D.



B. Offset in rocks at Morrell's tract, above tunnel at Wright's station. This particular emplacement was not found in tunnel. G. A. W.

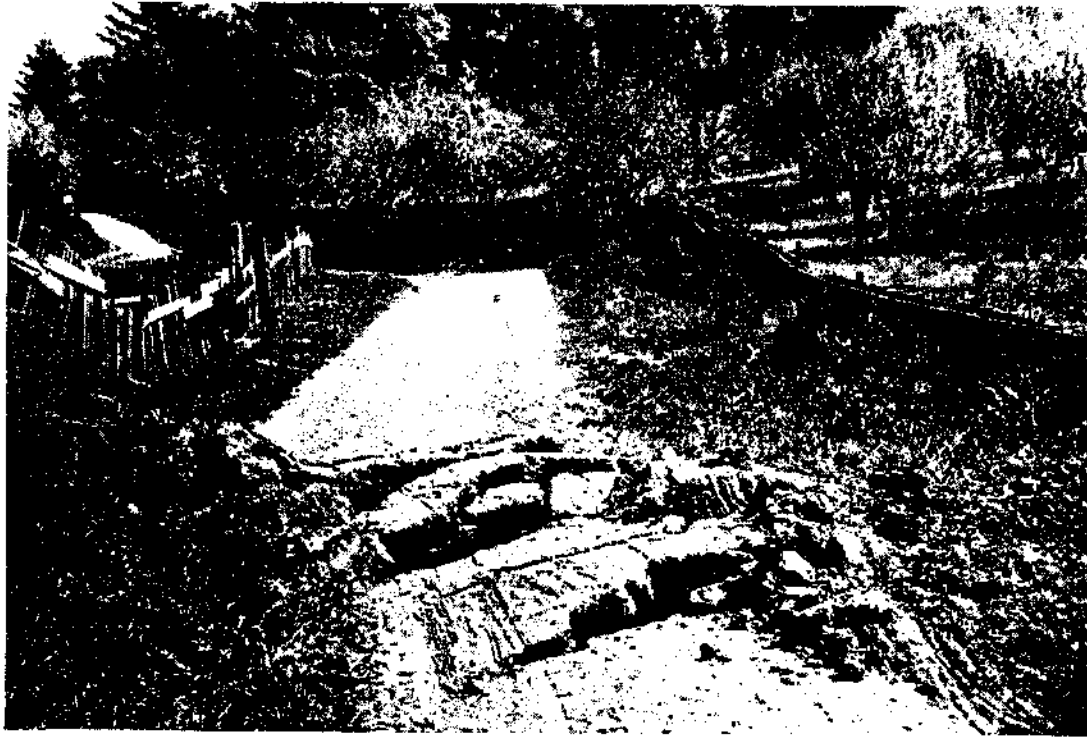

A. Offset in road near "Wright. Q. A. W.

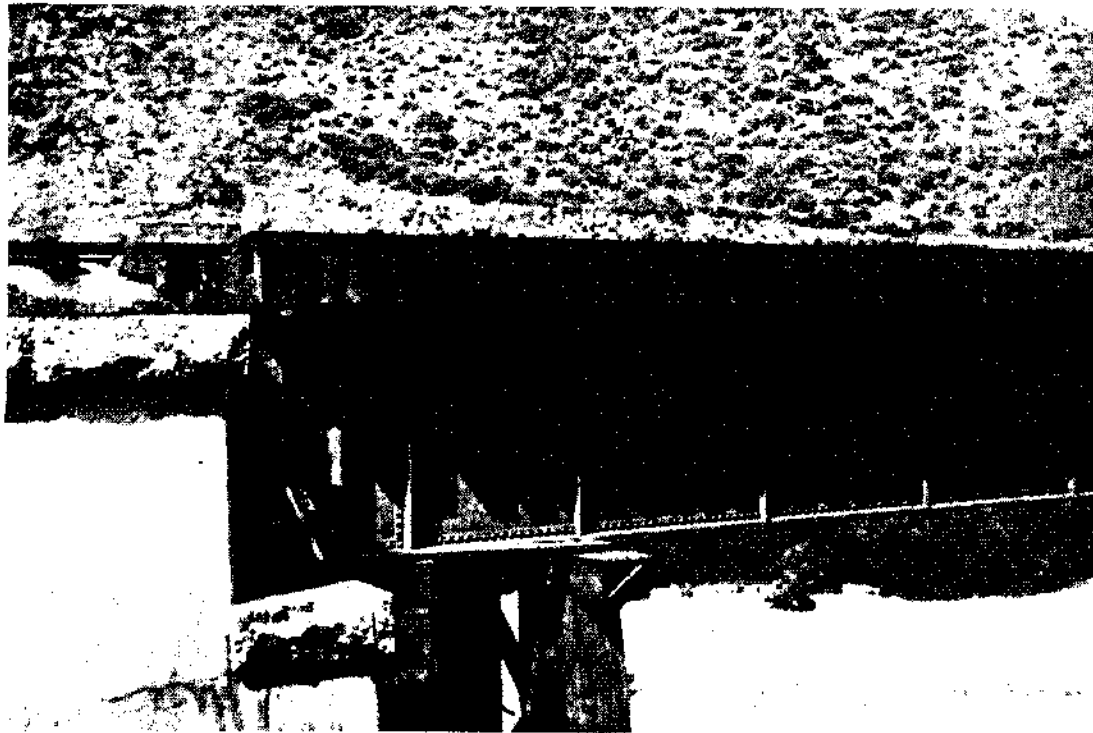

B. Steel bridge over Pajtro Eirer, near Oiiittenden, dragged from its abutment 3.5 fwt. Compare Fig. 43. A. O. L.

as a single fissure 3 inches wide, trending S.  $53^{\circ}$  E. In the lowland to the southeast there is little evidence of the fault, but crossing at right angles the county road running north and south about a mile east of San Juan, is a band of small cracks 15 feet wide, causing the road to sink 8 inches and making a marsh of the field beyond. This is believed to be the southernmost point of the recent opening of the fault. No trace of it could be found where it would have crossed roads beyond, nor were other cracks found or reported in this neighborhood. The disturbance affected the banks of the Pajaro River from Chitenden to Sargent, causing a cracking and sloughing of the banks into the stream but not a settling of the stream bed. The San Benito River was similarly shaken for about 3 miles up from its junction with the Pajaro. Cracks are also noticeable all along the Riverside road wherever it runs close to the river bank. The damage to the concrete abutments of the county bridge across the Pajaro River is due to this crowding in of the alluvial banks of the stream.

*The tunnel at Wright Station* (E. P. Carey). — Mr. Everett P. Carey reports that he made an examination of the tunnel at Wright Station soon after the earthquake, and again on February 17, 1907. The result of his observations is incorporated in the following memorandum:

The length of the tunnel is 6,200 feet. Its direction is S.  $48^{\circ} 24'.5$  W. A fissure crossed the tunnel 400 feet from the northeast portal, along which there was a lateral displacement of 4.5 feet. The movement on the southwest side was northerly with reference to the northeast side. Nothing of this fissure can now be seen, as the tunnel along that part has been excavated, the walls timbered and entirely obscured from view. My description rests on my examination soon after the earthquake, before any work had been done. The strike of this fissure is N.  $52^{\circ}$  W., making an angle of  $80^{\circ}$  with the trend of the tunnel, and it dips at an angle of about  $75^{\circ}$  to the west. The walls of the fissure were well smoothed and slicken-sided, but I did not determine the direction of the strike. Specimens from this fissure indicate that the fault occurred in sandstone, and that much movement had already taken place along the same fault in apparently a variety of directions. Specimens secured at the time have changed from a damp, sticky, clay-like mass to a relatively dry, hard, and crumbled condition. Streaks of light-colored sandstone occurred in this dark attrition material.

The damage to the tunnel itself consisted in the caving in of overhead rock; the crushing in toward the center of the tunnel of the lateral upright timbers, and the heaving upward of the rails, due to the upward displacement of the underlying ties. In some instances these ties were broken in the middle. In general the top of the tunnel was carried north or northeast with reference to the bottom. This seems to be the prevailing condition in the exposed part of the tunnel not yet repaired.

I examined with particular care the walls of the tunnel at several points where the damage to the timbers appeared to be greatest, more especially between 1,400 feet and 2,200 feet in from the opening at Wright. At each place I found several fissure lines running somewhat irregularly, but in general parallel to the fissure already described 400 feet in from the entrance at Wright. These fissures all contained more or less attrition material. Three of them I had an opportunity to examine better than the others. In each case two distinct sets of striae were found, one set vertical and the other set horizontal. The horizontal set was clearly more recent than the vertical set, and to all appearances might have been formed the day before. The three slicken-sided faults mentioned were the only ones that look as if recent movement had occurred. The rocks in the tunnel look like sandstones and jaspers of Franciscan age. According to the evidence, so far as it went, the whole of the top of the mountain is fissured thruout in such a way that a large movement could be distributed among several fissures and thus account for a relatively slight motion along any one fissure. The measuring of any minor movements in the tunnel would be difficult because of the caving in of the rocks at such points. It would seem, too, that such movement could occur without materially altering the line of the tunnel at that point, so far as the timbering is concerned.

As far as learned no recognized fissures or faults have been crossed by the workmen thus far, except the one 400 feet from the northeast portal. Nothing corresponding to the fissure passing Morrell's house has yet been found in the tunnel.

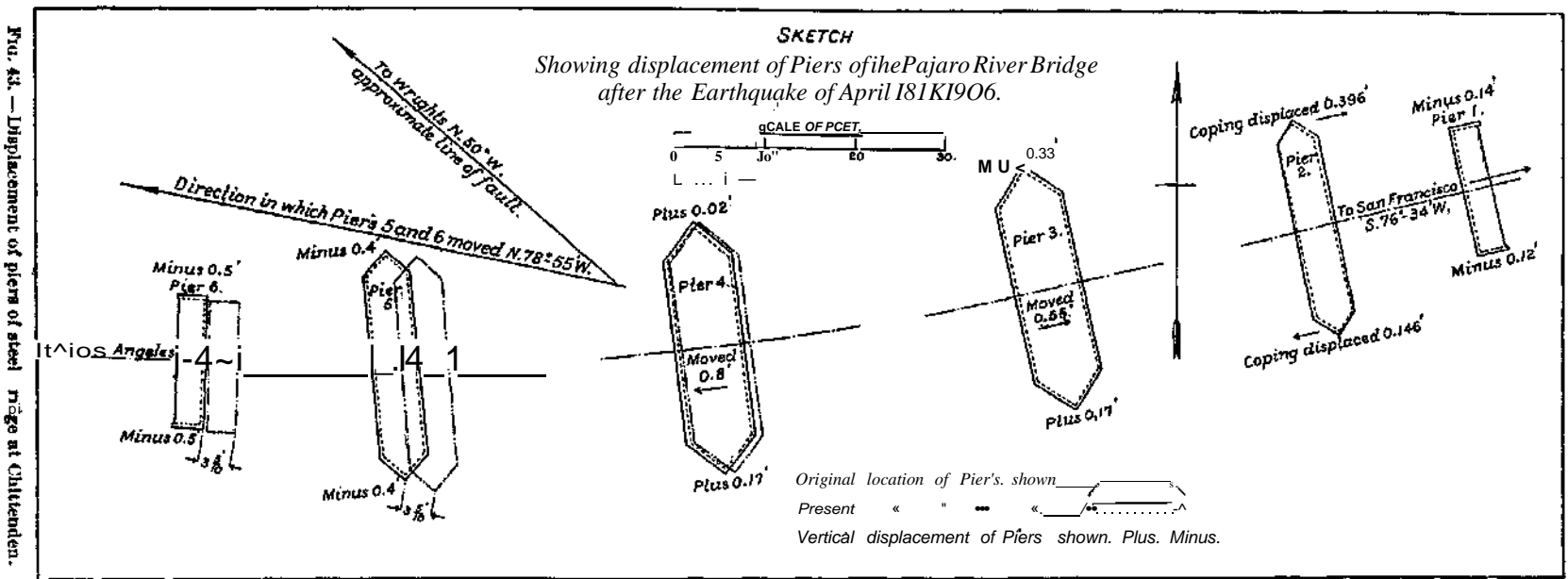
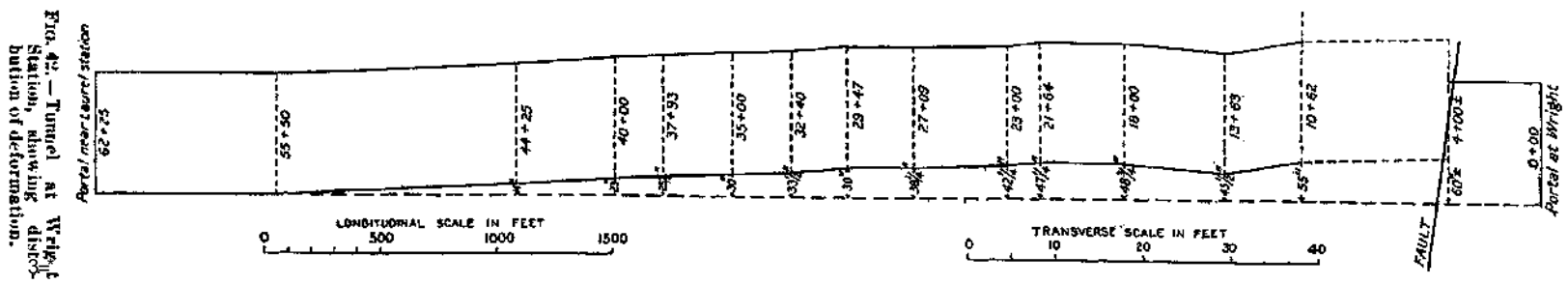

*Engineers' measurements of displacement.* — The reconstruction of the tunnel at Wright Station necessitated an instrumental survey of the displacement in so far as it immediately affected the structure. The results of this survey have been placed at the disposal of the Commission by Mr. J. D. Matthews, assistant resident engineer in charge of the work. The plot of the survey is given in fig. 42. The plot shows that, while the tunnel is traversed by only one fault fracture, at a distance of about 400 feet from the northeast portal the deformation has been distributed over a distance of nearly a mile. This deformation of the tunnel, or its departure from a straight line, is measured from a line drawn from the northeast portal to a point on the same side of the tunnel 675 feet in from the southwest portal. It indicates a bending of the ground to the northwest in the direction of the relative displacement on the southwest side of the fault. That is to say, the bending is in the opposite direction to that which would be characteristic of the drag of a fault. A possible explanation of this phenomenon is that the ground pierced by the tunnel was in a state of excessive elastic stress, even at the time the tunnel was constructed; and that the relief effected by the rupture rendered resilience operative and so caused the ground to be flexed in the sense opposite to that of a drag. The nature of the deformation of the ground on the northeast side of the fault is not yet known. It may be here mentioned, in regard to the effect of the fault upon the steel bridge at Chittenden, that, in addition to the cracking and displacement of the supporting piers, as noted by Mr. Waring, the distance between the abutments was lengthened about 3.5 feet, according to measurements supplied to the Commission by Mr. J. H. Wallace, Assistant Chief Engineer, Southern Pacific Company, and illustrated in the accompanying diagram, fig. 43.

## GEODETIC MEASUREMENTS OF EARTH MOVEMENTS.<sup>1</sup>

BY JOHN F. HAYPORD AND A. L. BALDWIN.

### GENERAL STATEMENT.

The Coast and Geodetic Survey has done much triangulation in California to serve as a control or framework for its surveys along the coast and other surveys. The results of all the triangulation, south of the latitude of Monterey Bay, together with the primary triangulation to the northward, have already been published.<sup>2</sup> In 1906 the results of the triangulation in California, from the vicinity of Monterey Bay northward, were being prepared for publication. The reports from various sources in regard to the effects of the earthquake of April 18, 1906, indicated that there had been relative displacements of the earth's surface of from 2 meters (7 feet) to 6 meters (20 feet) at various points near the great fault accompanying the earthquake. These were relative displacements of points on opposite sides of the fault and had been reported along all parts of the fault for 185 miles, from the vicinity of Point Arena, in Mendocino County, to the vicinity of San Juan, in San Benito County.<sup>3</sup> The average relative displacement was said to be about 3 meters (10 feet). Displacements of that size would so change the relative positions of points which had been determined by triangulation and so change the lengths and directions of the lines joining them that the triangulation would no longer be of value as a means of control for accurate surveys. The value of the triangulation could be restored only by repeating a sufficient amount of it to determine definitely the extent and character of the absolute displacements. It was, therefore, decided to repair the old triangulation, damaged by the earthquake, by doing new triangulation.

If the displacements of a permanent character had occurred in a narrow belt only, close to the fault, but a few triangulation points would have been affected. The available evidence, however, indicated that the movements probably extended back from the fault for many miles on each side, and that the new triangulation necessary for repair purposes must, therefore, cover a wide belt.

The new triangulation to repair the damage was completed in July, 1907. In addition to serving this practical purpose, it has shown the character of the earth movements of 1906, which were found to extend back many miles on each side of the fault. These are very interesting results from a purely scientific point of view. Moreover, there came to light, during the study of the movements of 1906, entirely unexpected evidence of earlier earth movements, probably in 1868, which also affected a large area.

The purpose of this paper is to set forth fully the amount and nature of these two great displacements of large portions (at least 4,000 square miles) of the earth's crust and to indicate the degree of certainty in regard to these displacements warranted by the evidence.

### EXTENT OF NEW TRIANGULATION.

The new triangulation done during the interval July 12, 1906, to July 2, 1907, extends continuously northwestward from Mount Toro, in Monterey County, and Santa Ana Mountain, in San Benito County, to Ross Mountain, and the vicinity of Fort Ross, in Sonoma County. This new continuous triangulation, as indicated on map No. 24, extends over an area 270 kilometers (170 miles) long and 80 kilometers (50 miles) wide, at its widest part. It includes the station known as Mocho, about 11.1 miles northeast from Mount Hamilton

<sup>1</sup> Published by permission of the Superintendent of the Coast and Geodetic Survey.

<sup>2</sup> See Appendix 9 of the Report of the Coast and Geodetic Survey for 1904, *Triangulation in California*, Part I, by A. L. Baldwin, Computer.

<sup>3</sup> Preliminary Report, State Earthquake Investigation Commission, Berkeley, May 31, 1906.

and a station on Mount Diablo, both on the eastern side of the fault and 53 kilometers (33 miles) from it. It also includes the Farallon Light-house on the west side of the fault and 36 kilometers (22 miles) from it. There were, in all, 51 old triangulation stations which were recovered and their new positions accurately determined by the new triangulation. The stations had been marked upon the ground by stone monuments, by bolts in rock, etc., or by permanent structures such as the Farallon Light-house, Point Reyes Light-house, and the small dome of Lick Observatory, or were themselves permanent marks; as, for example, Montara Mountain peak (a sharp peak).

This continuous scheme consists of a chain of primary triangulation comprizing the eleven occupied stations, Mount Toro, Gavilan, Santa Cruz Azimuth Station, Loma Prieta, Sierra Morena, Mocho, Mount Tamalpais, Point Reyes Hill, Tomales Bay, Sonoma Mountain, and Ross Mountain; triangulation of the secondary grade of accuracy extending from the stations, Mount Tamalpais, Mount Diablo, Rocky Mound, and Red Hill, to the Pulgas Base near the southern end of San Francisco Bay, and triangulation of a tertiary grade of accuracy in three different localities; namely, in the vicinity of Colma, west of San Francisco Bay, along Tomales Bay, and in the vicinity of Fort Ross, Sonoma County.

The primary and secondary triangulation are shown on map No. 24, and the tertiary triangulation on map No. 25. On these two maps the straight blue lines indicate lines over which observations were taken in the new triangulation. The small red circles indicate stations marked upon the ground, of which the relative positions were fixed by the triangulation. Observations were taken in both directions over each blue line which is unbroken, thruout its length. Observations were taken in one direction, only, from the solid end toward the broken end, over each blue line which is broken at one end. A station from which no blue line is drawn unbroken was not occupied. The position of such a station was determined by intersections from the occupied stations.

In addition to this continuous triangulation, a detached piece of new triangulation of the secondary grade of accuracy, connecting old triangulation stations, was done in the vicinity of Point Arena. (See map No. 25.) This makes the total number of old triangulation stations which were recovered and redetermined 61.

In connection with the new triangulation, astronomic determinations of azimuth or true direction were made by observations on Polaris at the stations Mount Tamalpais, Mocho, and Mount Toro.

Four different observers, each with his own complete outfit and party, were engaged in the new work for an aggregate period of 35 months. The observers were all field officers of the Coast and Geodetic Survey, with previous experience in triangulation.

Mr. J. F. Pratt, Assistant, was in the field from August 4, 1906, to July 2, 1907, and made the observations at the five primary stations, Ross Mountain, Sonoma Mountain, Tomales Bay, Point Reyes Hill, and Mount Tamalpais.

Mr. W. B. Fairfield, Assistant, was in the field from August 11, 1906, to May 29, 1907. He did nearly all of the Tomales Bay triangulation, made the observations at the primary stations, Mocho and Sierra Morena, and did a part of the secondary triangulation in the vicinity of Pulgas Base.

Mr. C. H. Sinclair, Assistant, was in the field from July 14, 1906, to April 10, 1907. He made the observations at the primary stations, Santa Cruz Azimuth Station, Loma Prieta, Gavilan, and Mount Toro, and also did a part of the secondary triangulation in the vicinity of Pulgas Base.

Mr. Edwin Smith, Assistant, was in the field from July 12 to July 24, 1906, engaged in making the reconnaissance and other preparations for triangulation along Tomales Bay. He was then called away on other duty and Assistant Fairfield completed the Tomales Bay triangulation. Between September 26, 1906, and February 26, 1907, Mr. Smith did



the secondary triangulation in the vicinity of Point Arena and the tertiary triangulation in the vicinity of Fort Ross and in the vicinity of Colma.

These observers remained at their work continuously in spite of many delays and discomforts due to fog, rain, snow, gales, and roads which were at times nearly or quite impassable. To them must be given the credit for overcoming the difficulties and securing the observations of the necessary high grade of accuracy.

#### THE OLD TRIANGULATION.

The old triangulation fixing the positions of the points before the earthquake of April 18, 1906, was done in many years, extending from 1851 to 1899, as a part of the regular work of the Coast and Geodetic Survey and without reference to the possible future use of this triangulation as a means of determining the movements of permanent character due to earthquakes. During the earlier years certain parts of this old triangulation had existed as detached triangulation not connected with other parts. Before 1906, however, all parts of the old triangulation had been connected with each other by triangulation to form one continuous scheme. It was also connected with other triangulation extending to many parts of the United States, including many of the interior states, as well as the Atlantic and Gulf Coasts.

In connection with studies of the evidence as to the earth movements set forth in this paper, it is important to note briefly the dates of the old triangulation which serves, in connection with the new triangulation of 1906-1907, to determine changes in positions of marked points on the earth's surface.

During the years 1854-1860 primary triangulation was carried from the stations, Rocky Mound, Red Hill, and Mount Tamalpais, northward to Ross Mountain, thru a primary scheme practically identical with that shown on map No. 24, except that the station Bodega was occupied in this earlier triangulation, tho not in 1906-1907.

Tertiary triangulation, following substantially the scheme shown on map No. 25, was also done in 1856 to 1860, along Tomales Bay, starting with the line Tomales Bay-Bodega, of the primary triangulation referred to in the preceding paragraph. In connection with this work, the station Chaparral of the Fort Ross triangulation, shown on map No. 25, was also determined.

Primary triangulation was done during the years 1851 to 1854, connecting the group of stations, Mount Diablo, Rocky Mound, Red Hill, with the Pulgas Base, the scheme being somewhat different from that shown on map No. 24, but equally direct and strong.

During the years 1854-1855, 1864, 1866, primary triangulation was done connecting the stations in the vicinity of Rocky Mound, referred to in the preceding paragraph, with stations Gavilan, Santa Cruz, and Point Pinos Light-house around Monterey Bay. This triangulation, for the greater part of its length, consists of a single chain of triangles, affording, therefore, comparatively few checks upon the results.

This practically completes the statement of triangulation done before 1868 which is concerned in the present investigation. The extent of the triangulation done between 1868 and 1906 is stated separately in the following paragraphs.

Northward of the line Mount Diablo-Mount Tamalpais, but one station of the primary scheme, shown on map No. 24, was determined by primary triangulation in the interval 1868-1906; namely, Ross Mountain. It was determined directly from the stations Mount Tamalpais, Mount Diablo, and Mount Helena of the transcontinental triangulation.<sup>1</sup>

During the years 1876-1887, primary triangulation was extended southward (by substantially the same scheme as that shown on map No. 24, except that station Gavilan was omitted) from the line Mount Diablo-Mount Tamalpais to the line Mount Toro-

<sup>1</sup> See The Transcontinental Triangulation, Special Publication No. 4, pp. 597-608.

Santa Ana. Some pointings were also taken on Gavilan, Point Pinos Light-house, and other stations in this vicinity, but not from a sufficient number of stations to furnish checked determinations independent of earlier determinations made before 1868.

Secondary triangulation near Point Arena, forming the western extremity of the transcontinental triangulation, was done in the interval 1870-1892, the scheme being substantially the same as that shown on map No. 25, except that all stations were occupied. The triangulation fixing the initial stations, Fisher and Cold Spring, has been published.<sup>1</sup>

Tertiary triangulation in the vicinity of Fort Ross was done in 1875-1876, following a scheme similar to that shown on map No. 25, and starting from the line Bodega Head-Ross Mountain, as determined before 1868.

Tertiary triangulation was done during various years from 1851-1899, extending from the vicinity of the Pulgas Base northward, spanning San Francisco Bay, to the Golden Gate, and thence southward to the vicinity of Colma, including stations shown on sketch No. 4 on map No. 25. The greater portion of this triangulation was done before 1868, but it is impracticable to separate the computations into two parts dealing with triangulation before and triangulation after 1868, respectively.

#### PERMANENT DISPLACEMENTS PRODUCED BY THE EARTHQUAKES OF 1868 AND 1906.

The following tables, Nos. 1, 2, and 3, show the permanent displacements of various points as caused by the earthquakes of 1868 and 1906. These permanent displacements were determined by comparisons of the positions of identical points upon the earth's surface as determined by triangulation done before and after the earthquakes in question.

While for the sake of brevity in statement these movements are referred to the earthquakes of 1868 and 1906, the evidence furnished by the triangulation simply indicates the fact that the displacements in question took place sometime during the two blank intervals within which there was no triangulation done fixing the points in question; namely, the interval 1866-1874, including the 1868 earthquake, and the interval 1892 to July, 1906, including the 1906 earthquake. Neither does the triangulation furnish any evidence indicating whether the displacements took place gradually, extending over many months and possibly years, or whether they took place suddenly. The evidence connecting the displacements of 1906 with the particular earthquake and indicating that they were sudden comes from other sources and will be commented upon later in this report.

The permanent displacements indicated in tables 1, 2, and 3, must be carefully distinguished from the vibrations of a more or less elastic character which take place during earthquakes. These vibrations die down in a few seconds, minutes, or hours. While they are in progress, a given point on the earth's surface is in continuous motion along a more or less complicated path which turns upon itself and leaves the point, at the end of the vibration, near the initial position. The displacements indicated in tables 1, 2, and 3, on the other hand, remain for years, possibly for centuries. They are of a permanent character. The displaced point remains in the new position until another displacement occurs in some later earthquake, or possibly by slow relief of strain accompanied by a creeping motion which causes a new permanent displacement. In tables 1, 2, and 3, the first column gives the name of the station by which it may also be identified on map 24 or on map 25, or both. The second column gives its latitude at the time indicated in the heading. The third column gives the seconds, only, of the new latitude at the later time indicated in the heading. The fourth and fifth columns have the same significance with reference to the longitude that the second and third have with reference to the latitude of each point. The sixth column gives the north and south component of the displace-

<sup>1</sup> See The Transcontinental Triangulation, Special Publication No. 4, pp. 597-010.

Table 1.—Displacements of 1906.

STATION	LATITUDE AFTER 1868		LATITUDE in 1906-07	LONGITUDE AFTER 1868		LONGITUDE 1906-07	SOUTHWARD COMPONENT OF DISPLACEMENT	EASTWARD COMPONENT OF DISPLACEMENT	DIRECTION OF DISPLACEMENT	AMOUNT OF DISPLACEMENT		RELATION TO FAULT		DEGREE OF CERTAINTY	
	°	'		°	'					Meters	Feet	Km.	Miles		Dir.
GROUP 1.															
Rocky Mound . . . .	37°	52'	57.253"	122°	14'	30.507"	30.515"	-0.28	-0.20	145°	0.34	1.1	32 20	E	Doubtful.
Red Hill . . . . .	37	33	04.730	122	05	40.982	40.975	-0.25	+ 0.17	215	0.30	1.0	19 12	E	Do.
Sierra Morena . . . .	37	24	38.266	122	18	28.006	28.054	- 1.20	-1.18	136	1.68	5.5	4.3 2.7	W	Certain.
Mount Tamalpais . . .	37	55	27.507	122	35	45.242	45.228	+ 0.46	+ 0.34	324	0.58	1.9	6.4 4.0	E	Do.
Farallon Lighthouse .	37	41	58.250	123	00	03.605	03.669	-0.83	-1.57	118	1.78	5.8	37 23	W	Do.
Pt. Revest Light-house	37	59	45.458	123	01	20.577	20.618	-0.43	- 1.00	113	1.09	3.6	19 12	W	Doubtful.
Point Reyes Hill . . .	38	04	48	122	52	01	.....	(- 2.96)	(- 2.25)	(143)	(3.72)	(12.2)	2.7 1.7	W	Inferred, certain.
Tornales Bay . . . .	38	10	55	122	56	47	.....	(- 3.06)	(- 2.41)	(142)	(3.89)	(12.8)	2.1 1.3	W	Do.
Bodega . . . . .	38	18	24	123	00	04	.....	(+ 1.16)	(+ 0.89)	(323)	(1.47)	(4.8)	2.0 1.2	E	Inferred, reasonably certain.
Ross Mountain . . . .	38	30	20.583	123	07	09.221	09.204	+ 0.34	+ 0.41	309	0.53	1.8	7.0 4.3	E	Doubtful.
GROUP 3.															
Black Ridge 2 . . . .	37	44	54.214	122	27	59.502	59.505	+ 0.22	-0.07	19	0.23	0.7	7.0 4.3	E	Doubtful. <sup>1</sup>
Bonita Pt. Light-house	37	48	57.447	122	31	43.569	43.554	+ 2.59	+ 0.37	352	2.62	8.6	6.0 3.7	E	Do.
San Bruno Mountain .	37	41	16.130	122	26	05.344	05.334	+ 0.03	+ 0.24	277	0.25	0.8	5.1 3.2	E	Do.
Black Bluff . . . . .	37	43	10.158	122	30	12.684	12.672	+ 0.28	+ 0.29	313	0.40	1.3	2.5 1.6	E	Do.
Road . . . . .	37	37	57.595	122	28	28.512	28.559	-2.16	-1.15	152	2.45	8.0	1.5 0.9	W	Do.
Flat . . . . .	37	36	51.991	122	27	35.197	35.236	-2.13	-0.96	156	2.33	7.7	1.5 0.9	W	Do.
False Cattle Hill 2 . .	37	36	50.401	122	29	40.926	40.967	- 1.82	- 1.01	151	2.08	6.8	4.1 2.5	W	Do.
Montara Mountain Pk.	37	33	42.506	122	28	36.940	36.904	- 1.33	+ 0.88	214	1.59	5.2	6.1 3.8	W	Do.
San Pedro Rock . . . .	37	35	44.158	122	31	22.422	22.441	-2.50	-0.47	169	2.54	8.3	7.4 4.6	W	Do.
GROUP 4.															
Bodega Head . . . . .	38	18	29	123	03	45	.....	(- 3.56)	(- 0.52)	(172)	(3.60)	(11.8)	2.2 1.4	W	Inferred, certain.
Tomales Point . . . .	38	12	46	122	58	14	.....	(- 2.81)	(- 2.24)	(141)	(3.59)	(11.8)	2.0 1.2	W	Do.
Foster . . . . .	38	08	13	122	54	23	.....	(- 3.61)	(- 2.83)	(142)	(4.59)	(15.1)	1.9 1.2	W	Do.
Smith . . . . .	38	14	52	122	56	09	.....	(+ 1.46)	(+ 0.80)	(331)	(1.66)	(5.4)	2.6 1.6	E	Do.
Mershon . . . . .	38	10	55	122	54	06	.....	(+ 1.90)	(+ 0.42)	(348)	(1.95)	(6.4)	1.1 0.7	E	Do.
Hans . . . . .	38	07	58	122	52	02	.....	(+ 1.94)	(- 0.23)	(7)	(1.95)	(6.4)	0.5 0.3	E	Inferred, doubtful.
Hammond . . . . .	38	04	45	122	48	35	.....	(+ 1.79)	(-1.42)	(38)	(2.28)	(7.5)	1.2 0.7	E	Do.

U.S. GEOLOGICAL SURVEY  
 DEPARTMENT OF THE INTERIOR  
 BUREAU OF GEOGRAPHIC NAMES  
 WASHINGTON, D. C.

Station	Group	38	25	53.725	53.704	0	0	0	04.05	+ 0.65	+ 1.09	801	1.27	4.2	C0	E	Reasonably cert.
Peaked Hill	Group 5.																
Lancaster		38	25	16.134	16.086	18	44.2	0	44.28	+ 1.48	+ 0.97	317	1.77	5.8	13.5	E	Assumed.
Chaparral		38	25	33.964	33.927	10	56.2	0	56.28	+ 1.14	+ 0.70	318	1.84	4.4	11.2	E	Unmoved.
Dixon		38	25	30.735	30.703	11	54.4	0	54.48	+ 0.99	+ 0.94	319	1.37	4.5	3.9	E	Do.
Henry Hill		38	25	47.724	47.688	14	27.5	0	27.58	+ 1.11	+ 0.84	320	1.46	4.8	3.8	E	Do.
Salt Point		38	25	00.302	00.360	19	57.7	0	57.78	- 1.48	- 1.36	321	2.01	6.6	0.2	W	Do.
Horseshoe Point		38	25	27.969	28.004	22	09.4	0	09.48	- 1.08	- 1.02	322	1.48	4.9	0.9	W	Do.
Stockhoff		38	25	57.016	57.013	18	11.8	0	11.88	- 1.45	- 1.04	323	1.78	5.9	1.6	W	Do.
Timber Cove		38	25	59.557	59.615	16	35.5	0	35.58	- 1.70	- 1.31	324	2.22	7.3	1.2	W	Do.
Fort Ross		38	25	46.084	46.152	15	12.6	0	12.68	- 2.19	- 1.86	325	2.50	8.2	1.2	W	Do.
Pinnacle Rock		38	25	02.982	03.056	14	02.9	0	02.98	- 2.28	- 0.94	326	2.47	8.1	1.0	W	Do.
Kunke		38	25	34.972	35.029	18	07.3	0	07.38	- 1.76	- 1.52	327	2.33	7.6	0.2	W	Do.
Cold Spring	Group 6.	39	01	21.8	21.8	31	20.468	0	20.468						13.5	E	Assumed.
Fisher		39	01	59.721	59.721	123	35	0	35.08	+ 0.68	+ 0.41	328	0.79	2.6	11.2	E	Unmoved.
Dunn		39	01	39.986	39.986	123	38	0	38.08	+ 0.71	+ 0.43	329	0.83	2.7	3.9	E	Do.
Clark		39	01	37.744	37.744	123	37	0	37.08	+ 1.23	+ 0.89	330	1.51	5.0	3.8	E	Do.
Spur		39	01	16.549	16.549	123	41	0	41.08	+ 1.42	+ 0.53	331	3.27	10.7	0.2	W	Do.
Lane		39	01	34.636	34.636	123	41	0	41.08	- 3.14	- 0.89	332	2.67	8.8	1.5	W	Do.
Sh		39	01	58.425	58.425	123	40	0	40.08	- 2.56	- 0.77	333	2.46	8.0	5.7	W	Do.
Pt		39	01	45.079	45.16	123	41	0	41.08	- 2.31	- 0.80	334	2.57	8.4	6.4	W	Do.
Light-house		39	01	18.722	18.722	123	44	0	44.08	- 2.44	- 0.82	335	2.78	9.1	6.7	W	Do.
High		39	01	03.866	03.866	123	41	0	41.08	- 2.59	- 1.01	336	2.54	8.3	6.8	W	Do.
ema		39	01	18.927	19.045	123	43	0	43.08	- 2.40	- 0.82	337	2.54	8.3	7.6	W	Do.
Lick	Group 7.	37	20	31.511	31.511	121	38	0	38.08	+ 0.12	+ 0.12	338	0.12	0.1	8.8	E	Unmoved.
Let		37	20	40.912	40.912	121	50	0	50.08	+ 0.82	+ 0.82	339	0.97	0.2	8.8	E	Do.
Santa		36	37	08.821	08.821	122	01	0	01.08	+ 0.37	+ 0.37	340	0.62	0.1	18.0	W	Do.
Al		36	31	34.712	34.712	121	36	0	36.08	+ 0.30	+ 0.30	341	0.95	0.2	8.8	W	Do.
Santa Cruz Az. Sta.		36	58	42		122	03	19		- 1.78	- 1.78	342	(1.88)	(0.5)	10	W	Inferred, very doubtful.
Gavilero		38	45	21		121	31	11		+ 1.48	+ 1.48	343	(2.19)	(7.2)	6.4	W	Do.
Pt. Pinos Light-house		36	58	01		121	55	59		+ 2.86	+ 2.86	344	(3.09)	(10.1)	39	W	Do.
Point		36	37	59		121	55	32		+ 2.31	+ 2.31	345	(2.32)	(7.6)	39	W	Do.

Through the absolute displacements 3 are all doubtful, only two of the relative displacements are doubtful, namely, Bonita Point Light-house and Montara Mountain Peak.

Table 2.—Permanent Displacements in 1868.

STATION-	LATITUDE BEFORE 1868		LONGITUDE BEFORE 1868		LONGITUDE AFTER 1868	SOUTHWARD COMPONENT OF DISPLACEMENT	EASTWARD COMPONENT OF DISPLACEMENT	DIRECTION OF DISPLACEMENT	AMOUNT OF DISPLACEMENT		DEGREE OF CERTAINTY <sup>1</sup>
	Latitude	Longitude	Latitude	Longitude					Meters	Feet	
<b>GROUP 1.</b>											
Rocky Mound . . . . .	37°	52' 57.237"	57.253"	122° 14' 30.510"	30.507*	-0.49	+ 0.07	188°	0.50	1.6	Doubtful.
Red Hill . . . . .	37	33 04.717	04.730	122 05 41.003	40.982	-0.40	+ 0.52	232	0.65	2.1	Do.
Mount Tamalpais . . . . .	37	55 27.455	27.507	122 35 45.228	45.242	- 1.60	-0.34	168	1.64	5.4	Certain.
Farallon Light-house . . . . .	37	41 58.210	58.250	123 00 03.579	03.605	- 1.23	-0.64	153	1.39	4.6	Do.
Point Reyes Hill . . . . .	38	04 48.325	.....	122 52 00.801	.....	(- 1.51)	(- 0.31)	(168)	(1.54)	(5.0)	Inferred, certain.
Tomales Bay . . . . .	38	10 55.456	.....	122 56 46.733	.....	(- 1.56)	(- 0.22)	(172)	(1.57)	(5.2)	Do.
Bodega . . . . .	38	18 23.680	.....	123 00 03.726	.....	(- 1.62)	(- 0.11)	(176)	(1.62)	(5.3)	Inferred, reasonably certain.
Ross Mountain . . . . .	38	30 20.528	20.583	123 07 09.223	09.221	- 1.70	+ 0.05	182	1.70	5.6	Reasonably certain.
<b>GROUP 4.</b>											
Bodega Head . . . . .	38	18 29.249	.....	123 03 45.417	.....	(- 1.62)	(-0.11)	(176)	(1.62)	(5.3)	Inferred, certain;
Tomales Point . . . . .	38	12 45.732	.....	122 58 14.449	.....	(- 1.57)	(- 0.19)	(173)	(1.58)	(5.2)	Do.
Foster . . . . .	38	08 13.410	.....	122 54 23.271	.....	(- 1.54)	(- 0.26)	(170)	(1.56)	(5.1)	Do.
Smith . . . . .	38	14 51.518	.....	122 56 08.865	.....	(- 1.58)	(-0.17)	(174)	(1.59)	(5.2)	Do.
Mershon . . . . .	38	10 55.295	.....	122 54 06.016	.....	(- 1.56)	(- 0.22)	(172)	(1.57)	(5.2)	Do.
Hans . . . . .	38	07 58.492	.....	122 52 02.072	.....	(- 1.54)	(- 0.28)	(170)	(1.57)	(5.2)	Inferred, doubtful.
Hammond . . . . .	38	04 45.046	.....	122 48 34.993	.....	(- 1.51)	(- 0.31)	(168)	(1.54)	(5.1)	Do.
<b>GROUP 5.</b>											
Chaparral . . . . .	38	29 33.905	33.964	123 10 56.207	56.216	- 1.82	-0.22	173	1.83	6.0	Reasonably certain.
<b>GROUP 7.</b>											
Loma Prieta . . . . .	37	06 40.971	40.912	121 50 36.521	36.423	+ 1.82	+2.42	307	3.03	9.9	Certain.

Table 3.—Combined Displacements of 1868 and 1906.

STATION	LATITUDE BEFORE 1868	LATITUDE 1906-07	LONGITUDE BEFORE 1868	LONGITUDE 1906-07	SOUTHWARD COMPONENT OF DISPLACEMENT	EASTWARD COMPONENT OF DISPLACEMENT	DIRECTION OF DISPLACEMENT	AMOUNT OF DISPLACEMENT	RELATION to FAULT	DEGREE OF CERTAINTY
GROUP 1.										
Rooky Mound . . . . .	37° 52' 57.237"	57.262"	122° 14' 30.510"	30.515"	-0.77	- 0.12	171°	Meters Feet 0.78 2.6	Km. Miles Dir. 32 20 E	Doubtful.
Red Hill . . . . .	37 33 04.717	04.738	122 05 41.003	40.975	-0.65	+ 0.69	227	0.94 3.1	19 12 F	Certain.
Mount TamalpaLs . . . . .	37 55 27.455	27.492	122 35 45.228	45.228	- 1.14	0.00	180	1.14 3.7	6.4 4.0 E	Do.
Farallon Light-house . . . . .	37 41 58.210	58.277	123 00 03.579	03.669	-2.07	-2.20	133	3.02 9.9	37 23 W	Do.
Point Reyes Hill . . . . .	38 04 48.325	48.470	122 52 00.801	00.906	-4.47	-2.56	150	5.15 16.9	2.7 1.7 W	Do.
Tomales Bay . . . . .	38 10 55.456	55.606	122 56 46.733	46.841	-4.62	-2.63	150	5.32 17.5	2.1 1.3 W	Do.
Bodega . . . . .	38 18 23.680	23.695	123 00 03.726	03.694	-0.46	+ 0.78	239	0.90 3.0	2.0 1.2 E	Reasonably certain.
Ross Mountain . . . . .	38 30 20.528	20.572	123 07 09.223	09.204	- 1.36	+ 0.46	199	1.43 4.7	7.0 4.3 E	Do.
Sonoma Mountain . . . . .	38 19 24.539	24.579	122 34 27.894	27.891	- 1.23	+ 0.07	183	1.24 4.0	34 21 E	Certain.
GROUP 2.										
Pulgas E. Base . . . . .	37 28 36.265	36.258	122 08 08.143	08.129	4-0.22	+ 0.34	302	0.41 1.3	12 7 E	Doubtful.
Guano Island . . . . .	37 34 23.655	23.649	122 15 43.475	43.479	+ 0.18	-0.10	28	0.21 0.7	10 6 E	Do.
Pulgas W. Base . . . . .	37 28 48.787	48.764	122 15 15.681	15.673	+ 0.71	+ 0.20	344	0.74 2.4	3.5 2.2 E	Reasonably certain.
GROUP 4.										
Bodega Head . . . . .	38 18 29.249	29.417	123 03 45.417	45.443	- 5.18	-0.63	173	5.22 17.1	2.2 1.4 W	Certain.
Tomales Point . . . . .	38 12 45.732	45.874	122 58 14.449	14.549	-4.38	-2.43	151	5.01 16.4	2.0 1.2 W	Do.
Foster . . . . .	38 08 13.410	13.577	122 54 23.271	23.398	-5.15	-3.09	149	6.01 19.7	1.9 1.2 W	Do.
Smith . . . . .	38 14 51.518	51.522	122 54 08.865	08.839	-0.12	+ 0.63	259	0.64 2.1	2.6 1.6 E	Do.
Mershon . . . . .	38 10 55.295	55.284	122 54 06.016	06.008	+ 0.34	+ 0.20	330	0.39 1.3	1.1 0.7 E	Do.
Hans . . . . .	38 07 58.492	58.479	122 52 02.072	02.093	+ 0.40	- 0.51	52	0.65 2.1	0.5 0.3 E	Doubtful.
Hammond . . . . .	38 04 45.046	45.037	122 48 34.993	35.064	+ 0.28	- 1.73	81	1.75 5.7	1.2 0.7 E	Do.
GROUP 5.										
Chaparral . . . . .	38 29 33.905	33.927	123 10 56.207	56.187	-0.68	+ 0.48	216	0.83 2.7	1.6 1.0 E	Doubtful.
GROUP 7.										
Black Mountain . . . . .	37 19 09.810	09.761	122 08 49.462	49.402	+ 1.51	+ 1.48	316	2.11 6.9	14 0.9 E	Certain.
Lorna Prieta . . . . .	37 06 40.971	40.895	121 50 36.521	36.390	+ 2.34	+ 3.23	306	3.99 13.1	4.8 3.0 E	Do.
Santa Cruz Az. Sta. . . . .	36 58 42.106	42.027	122 03 18.728	18.702	+ 2.44	+ 0.64	345	2.52 8.3	19 12 W	Do.
(Javilan . . . . .	36 45 21.068	20.961	121 31 11.504	11.341	+ 3.30	+ 4.04	309	5.22 17.1	6.4 4.0 W	Do.
Pt. Pinos Light-house . . . . .	36 38 01.551	01.399	121 55 58.939	58.795	+ 4.68	+ 3.58	323	5.89 19.3	39 24 W	Do.
Point Pinos Lat. Sta.. . . . .	36 37 59.413	59.279	121 55 31.685	31.578	+ 4.13	+ 2.66	327	4.91 16.1	39 24 W	Do.

ment along a meridian. A plus sign in this column means that the point moved toward the south. The seventh column shows the east and west component of the motion. A plus sign in this column means that the point moved toward the east. The sixth and seventh columns were computed by converting the changes in latitude and longitude, respectively, into meters.

By combining the values given in columns 6 and 7, the direction and amount of the displacement were obtained as shown in columns 8, 9, and 10. In column 8 the direction of displacement is given, reckoned as geodetic azimuths are usually reckoned, clockwise around the whole circumference from south as zero. In this reckoning, west is  $90^\circ$ , north,  $180^\circ$ , and east,  $270^\circ$ . Column 9 gives the amount of displacement in meters and column 10 gives it in feet. Column 11 shows the approximate distance of the point from the fault of 1906, measured approximately at right angles to the fault. In this column E indicates that the point is to the east of the fault and W that it is to the west.

For example: The fifth line of table 1 indicates that during the earthquake of 1906 the Farallon Light-house moved 0.83 meter north and 1.57 meters west, or, in other words, moved 1.78 meters (5.8 feet) in azimuth  $118^\circ$ , or  $62^\circ$  west of north, and that it is 37 kilometers (23 miles) from the fault of 1906 and to the west of it.

In the heading, the expression "Before 1868" refers to years within the interval 1851-1866. The expression "After 1868" refers to years within the interval 1874-1891, and "1906-1907" refers to dates within the interval July, 1906-July, 1907.

The latitudes and longitudes given in tables are all computed upon the U. S. Standard Datum and differ somewhat from those now in use on the charts and maps of this region. They are, however, the latitudes and longitudes to which all charts and maps should ultimately conform.

Table 1 shows the displacements which occurred on April 18, 1906; table 2 shows the displacements which occurred in 1868, and table 3 shows the total, or combined displacements in both 1868 and 1906.

For some cases, as, for example, Point Reyes Hill, the separate displacements were not directly determined by the triangulation but only the combined displacements. In such cases, if probable values could be derived for the separate displacements, indirectly, by inference from surrounding points, they were so derived and placed in the table. In each case, such inferred displacements are clearly distinguished in the table from others which were determined directly by measurement, by leaving the third and fifth columns blank and by having the values in the sixth to tenth columns enclosed in parentheses.

All of the displacements given in tables 1-3 are computed upon the assumption that the two stations, Mount Diablo and Mocho, remained unmoved during the earthquake of April 18, 1906. The reasons why this assumption is believed to be true will be set forth fully in a later part of this report.

In the tables the points are separated into seven groups for convenience of discussion. Each group of points is fixed by a portion of the triangulation which may conveniently be considered as a unit in discussing the magnitude of the possible errors of the triangulation. The discussion of the observed displacements and the degree of certainty in regard to them is given after the tables and deals with each group in succession.

The apparent displacements, as shown in the above tables, are of course in part due to the unavoidable errors in the triangulation and in part are doubtless actual displacements of the points. The triangulation furnishes within itself the means of estimating its accuracy. If the observations were absolutely exact, the sum of the observed angles of each triangle would be exactly  $180^\circ$  plus the spherical excess of that triangle, and moreover the computation of the length of the triangle sides would show no discrepancies, starting from a given line and ending on a selected line, but proceeding thru the various alternative sets of triangles which it is possible to select connecting said lines. In any

actual case, neither of these ideal conditions is found. Each triangle has a closing error, and the lengths computed along different paths thru the triangulation show discrepancies. These closing errors and discrepancies are a measure of the accuracy of the triangulation.

The triangulation, both old and new, was adjusted by the method of least squares. This method of computation, as applied to triangulation, takes into account simultaneously all the observed facts in connection with a group of triangulation stations and also all the known theoretical conditions connecting the observed facts; such, for example, as those mentioned in the preceding paragraph, in regard to closures of triangles and discrepancies in length. It is the most perfect method of computation known. The results of the computation are a set of lengths and azimuths (true directions) of lines joining the triangulation stations and of latitudes and longitudes defining the relative positions of the stations which are perfectly consistent; that is, contain no contradictions one with another and are the most probable values which can be derived from the observations. In such a computation, the measures of the accuracy of the computed results appear in the form of corrections to observed directions from station to station, which it is necessary to apply in order to obtain the most probable results given by the computation. The greater the accuracy of the observations the smaller are the corrections to directions.

In the problem in hand, in which, at least for some points, the observed apparent displacement is of about the same magnitude as the possible error in the apparent displacement due to accumulated errors of observation, it is necessary to make a careful estimate of the errors of observation and of the uncertainties of the computed displacements. This has been done and the estimates are given in general terms in the following text and are indicated in the last column of the tables. These estimates will help the reader to avoid drawing conclusions in detail not warranted by the facts.

*Group 1. Northern part of primary triangulation.*—In this group, as shown by tables 1-3 (see also map 24), there are 11 points of which the positions were redetermined after the earthquake of April 18, 1906. Of these, 9 had been determined before 1868 and 7 between 1868 and 1906.

There is about 1 chance in 3 that each of the two apparent displacements of Rocky Mound, 0.50 meter (1.6 feet), in 1868 (table 2), and 0.34 meter (1.1 feet), in 1906 (table 1), is simply the result of errors of observation. Similarly there is about 1 chance in 3 that the apparent displacement of Red Hill in 1868, 0.65 meter (2.1 feet), is the result of errors of observation. The chances are about even for and against the apparent displacement of Red Hill in 1906, 0.30 meter (1.0 foot), being simply the result of errors of observation. The effect of errors of observation upon the apparent displacements are larger at these two points than they otherwise would be on account of the difficulty in this vicinity of separating the triangulation into two complete schemes, one before 1868 and one after that date, each strong and complete.

According to the evidence furnished by the triangulation, the apparent displacement of Ross Mountain in 1906, 0.53 meter (1.8 feet) in azimuth  $309^\circ$  ( $51^\circ$  E. of S.), is probably the result of errors of observation. This apparent displacement as computed depends on the accumulated errors of the two triangulations from Mount Diablo to Ross Mountain, a distance of 130 kilometers (81 miles). The apparent displacement of 0.53 meter almost directly toward Mount Diablo corresponds to a shortening on the line Ross Mountain-Mount Diablo by 1 part in 250,000, too small a change to be detected with certainty by the triangulation.

On the other hand, there is about 1 chance in 15 that the apparent displacement of Ross Mountain in 1868, 1.70 meters (5.6 feet), is due to errors of observation. It is reasonably certain that this is a real displacement.

The chances are about even for and against the apparent displacement of Point Reyes Light-house in 1906, 1.09 meters (3.6 feet), being due simply to errors of observation.



There is about 1 chance in 7 that the apparent displacement of Bodega, shown in table 3, is due to errors of observation. It is reasonably certain that this is a real displacement.

For the remaining six points in group 1, Sierra Morena, Mount Tamalpais, Farallon Light-house, Point Reyes Hill, Tomales Bay, and Sonoma Mountain, each of the apparent displacements given in the tables as observed is real, being in each case clearly beyond the maximum which could be accounted for as errors of observation.

Prof. George Davidson has believed for many years that Mount Tamalpais moved during the earthquake of 1868 and that the triangulations made before and after that date showed such a displacement. Accordingly in 1905, at his request, a reëxamination was made at the Coast and Geodetic Survey office of the evidence furnished by the triangulations, and the conclusion was reached that a real displacement of Mount Tamalpais occurred in 1868. At that time, however, convincing evidence was not discovered that any other triangulation station moved in 1868. In the more extensive studies made in connection with the present investigation, and with the additional skill acquired in recognizing the effects of earthquakes upon triangulation, it became evident, as shown in table 2, not only that Mount Tamalpais moved in 1868, but also that the Farallon Light-house and Ross Mountain moved at that time, the three apparent displacements being clearly beyond the range of possible errors of triangulation. The displacements for these three stations are similar. The amount of the displacement is least at Farallon Light-house, 1.39 meters (4.6 feet), and greatest at Ross Mountain, 1.70 meters (5.6 feet). The azimuth of the displacement is least at the Farallon Light-house,  $153^{\circ}$  ( $27^{\circ}$  W. of N.), and is greatest at Ross Mountain,  $182^{\circ}$  ( $2^{\circ}$  E. of N.). (See map 24.) The apparent differences in direction and amount of the three displacements may or may not be real. It is certain therefore that in 1868 the large part of the earth's surface included between these three stations, at least 700 square miles, moved about 1.5 meters (4.9 feet), in about azimuth  $168^{\circ}$  ( $12^{\circ}$  W. of N.).

Within the triangle defined by the three stations, Mount Tamalpais, Farallon Light-house, and Ross Mountain, which certainly were displaced in 1868, are the three stations, Point Reyes Hill, Tomales Bay, and Bodega, of group 1. It is therefore believed to be reasonably certain that these stations were displaced at that time. The probable displacements were interpolated from the three displacements observed at the first three stations, taking into account the relative positions of the stations. The resulting interpolated displacements are shown in table 2. Other evidence, tending to show that these interpolated values of the displacements are real, will be brought forward later.

For the three stations, Point Reyes Hill, Tomales Bay, and Bodega, the positions were determined before 1868 and after the earthquake of 1906, but not during the interval 1868-1906; hence the computation of the positions determined by triangulation for these stations furnishes simply the combined displacements of 1868 and 1906 as shown in table 3. As noted in the preceding paragraph, the displacement of 1868 has, for these three stations, been interpolated from surrounding stations and entered in table 2. The differences<sup>1</sup> between these inferred displacements in table 2 and the observed combined displacements in table 3 were then taken and are shown in table 1, as inferred displacements in 1906. As indicated in the marked column of table 1, these inferred displacements are believed to be certain for two of these points and somewhat doubtful for the third, Bodega.

The doubtful apparent displacements at Rocky Mound and Red Hill in 1868 (see table 2) agree with other displacements which are certain, in having a decided northward component.

In table 1, showing the displacements of 1906, there are three stations, Sierra Morena, Mount Tamalpais, and Farallon Light-house, at which observed displacement is certain,

<sup>1</sup> The differences were taken separately for the meridian components and the prime vertical components and then combined to secure the direction and amount of the resultant.

and two others. Point Reyes Hill and Tomales Bay, in group 1, at which the displacement inferred from indirect evidence is considered certain. Of these five stations, the four which are to the westward of the fault of 1906 moved northwestward and the one which is to the eastward of the fault, Mount Tamalpais, moved southeastward (see map 24). The displacements of four of the five points were nearly parallel, their azimuths being for Sierra Morena, Point Reyes Hill, and Tomales Bay,  $136^\circ$ ,  $143^\circ$ , and  $142^\circ$  respectively, with a mean of  $140^\circ$  ( $40^\circ$  W. of N.), while that of Mount Tamalpais was  $324^\circ$  ( $36^\circ$  E. of S.). The azimuth of the displacement at the fifth, Farallon Light-house, is  $118^\circ$  ( $62^\circ$  W. of N.) at an angle of about  $22^\circ$  with the other four. The portion of the fault near these points has an azimuth of about  $145^\circ$  ( $35^\circ$  W. of N.), hence the displacement of four of the five points was practically parallel to the fault, the departure being in each case within the range of possible error of the determination of the displacement. For the four points to the westward of the fault, the amounts of the displacement are in the inverse order of their distances from the fault, with the exception of Sierra Morena. For Tomales Bay, which is only 2.1 kilometers (1.3 miles) from the fault, the displacement is greatest, 3.89 meters (12.8 feet), and for the Farallon Light-house, which is 37kilometers (23 miles) from the fault, the displacement is much less, 1.78 meters (5.8 feet).

From these five stations, one may deduce four laws governing the distribution of the earth movement which occurred on April 18, 1906. First, points on opposite sides of the fault moved in opposite directions, those to the eastward of the fault in a southerly direction and those to the westward in a northerly direction. Second, the displacements of all points were approximately parallel to the fault. Third, the displacements on each side of the fault were less, the greater the distance of the displaced points from the fault. Fourth, for points on opposite sides of the fault and the same distance from it, those on the western side were displaced on an average about twice as much as those on the eastern side.

If the proof of these four deduced laws rested upon the evidence of these five stations only, it would be insufficient to convince one. Much other evidence in proof of these four deduced laws will be shown in this report. The laws are here stated in order that they may be kept in mind and tested by the evidence as presented.

The apparent displacements of the remaining five points of group 1 may now be compared with the stated laws.

The displacement of Point Reyes Light-house, believed to be determined with reasonable certainty, is apparently about 1.6 meters (5 feet) greater than and differs about  $32^\circ$  in direction from the displacement which might be inferred from the above laws and comparison with the surrounding stations.

The displacement of Bodega, of which the determination is somewhat doubtful, is just what would be inferred from the deduced laws, as its amount is greater than for Mount Tamalpais, corresponding to the fact that it is closer to the fault, and its azimuth agrees within  $2^\circ$  with that of the fault.

The displacement of Ross Mountain, of which the determination is doubtful, agrees very closely in amount with that at Mount Tamalpais and differs only  $15^\circ$  in direction. Ross Mountain is on the same side of the fault as Mount Tamalpais and at practically the same distance from it.

The apparent displacements of Rocky Mound and Red Hill, 32 and 19 kilometers (20 and 12 miles) from the fault and to the eastward of it, of which the determinations are doubtful, agree with the laws in being small but are contradictory as to direction.

For Sonoma Mountain the triangulation serves to determine the combined displacements of 1868 and 1906 as shown in table 3, but not the separate displacements, as this station was not involved in triangulation done between 1868 and 1906. The combined displacements at Sonoma Mountain are of about the same amount and are in approximately the same azimuth as displacements of 1868 at Mount Tamalpais, Point Reyes Hill, Tomales

Bay, Bodega, and Ross Mountain (see table 2). Some of the internal evidence of computations of triangulation indicate that Sonoma Mountain moved in 1868. According to the general laws of distribution of the earth movement of 1906 as derived from other stations Sonoma Mountain did not move much, if any, being far to the eastward of the fault, 34 kilometers (21 miles). For these three reasons it is believed to be probable that the whole displacement of Sonoma Mountain, 1.24 meters (4.0 feet), in azimuth  $183^\circ$  ( $3^\circ$  E. of N.), which certainly took place sometime between 1860 and July, 1906, all occurred in 1868.

*Group 2. Southern end of San Francisco Bay.* — In this group there are three new points not yet considered and Red Hill which has already been considered in group 1. The three new stations, Guano Island, Pulgas East Base, and Pulgas West Base (see map 24), were determined in 1851-1854 and again after the earthquake of 1906. No determination was made between 1868 and 1906, hence these points are entered in table 3, the combined displacements of 1868 and 1906 being determined, but not the separate displacements.

A study of the errors of the triangulation shows that the apparent displacement of Guano Island, 0.21 meter (0.7 foot), is probably due to errors of observation, and that there is one chance in three that the apparent displacement of Pulgas East Base, 0.41 meter (1.3 feet), is also due to errors of observation.

The determination of the displacement of Pulgas West Base, 0.74 meter (2.4 feet), is reasonably certain, there being about one chance in twelve that it is due to errors of observation.

Tho the determinations of the separate apparent displacements of Red Hill in 1868, 0.65 meter (2.1 feet), and in 1906, 0.30 meter (1.0 foot), are each doubtful, the combined displacement as observed, shown in table 3, 0.94 meter (3.1 feet), is certain.

It is therefore reasonably certain that there was a relative displacement of Pulgas West Base and Red Hill as indicated in table 3, Red Hill moving 0.94 meter (3.1 feet), in azimuth  $227^\circ$  ( $47^\circ$  E. of N.), and Pulgas West Base 0.74 meter (2.4 feet), in azimuth  $344^\circ$  ( $16^\circ$  E. of S.). This lengthened the line Pulgas West Base to Red Hill, 16 kilometers (10 miles) long, 0.50 meter (1.6 feet), or one part in 32,000. It also changed the azimuth of this line by  $11''$ , from  $240^\circ 44' 35''$  to  $240^\circ 44' 24''$ , rotating it in a counterclockwise direction.

The red arrows on map 24, showing apparent displacements, indicate that the apparent displacements of Guano Island and Pulgas East Base, which are considered doubtful, are not inconsistent with the displacements of Red Hill and Pulgas West Base. Apparently the area included between these four stations was distorted by stretching and rotated in a counterclockwise direction.

There is no evident method of ascertaining whether the displacement of Pulgas West Base took place in 1868 or 1906 or in part at each time. The displacement is nearly in the direction corresponding to the laws governing the displacements of 1906, as already stated in connection with group 1. Pulgas West Base is to the eastward of the fault of 1906 and slightly nearer to it than Mount Tamalpais and Ross Mountain and hence, according to the laws referred to, should be displaced in the same direction as these two points (see table 1), and by a similar amount. This is the fact.

*Group 3. Vicinity of Colma.* — There are nine points in group 3 all determined by triangulation in 1899 or earlier, and redetermined after the earthquake of 1906 (see table 1). The earlier determination was made by secondary and tertiary triangulation, extending from the vicinity of Pulgas Base northwest, spanning San Francisco Bay to the Golden Gate, and thence southward to Colma. The earlier positions of these nine points are subject to the effect of accumulated errors in this chain of triangulation about 60

kilometers (40 miles) long. They are subject, therefore, to an error of position common to them all, which may be as great as 7 meters (23 feet). With the exception of Montara Mountain Peak and Bonita Point Light-house these points are all within 13 kilometers (8 miles) of San Bruno Mountain and therefore their relative positions were determined with considerable accuracy.

In the triangulation of 1906-1907, the position of San Bruno Mountain, which is in the midst of this group, was determined by secondary triangulation in connection with group 2 as indicated on maps 24 and 25, a direct and strong determination. The new azimuth was also carried into the triangulation of group 3 with a high degree of accuracy in this same manner. No new determination was made of the starting length in group 3. It was assumed that the length San Bruno Mountain to Black Ridge 2 had remained unchanged during the earthquake of 1906 and the old value of that length was used in the computation of the triangulation of 1906-1907. As a check upon the assumption that this length remained unchanged, it is to be noted that the azimuths of this line before and after the earthquake of 1906 were found to differ only by 9.3", which is within the possible range of errors of observation in the earlier triangulation.

For the reasons stated above, the apparent absolute displacements shown in table 1 for group 3, as referred to Mocho and Mount Diablo as fixt points, are probably due to errors of observation.

On account, however, of the fact that seven of the nine points in this group are within a rather small area, their relative displacements are determined with considerable accuracy, the errors of length and azimuth having less effect in producing errors in relative positions, the smaller the area covered by a triangulation. Montara Mountain Peak and Bonita Point Light-house are each determined with a low grade of accuracy. They are each far from the stations occupied in the triangulation and the lines which determine them intersect at a small angle; hence even their relative displacements are uncertain. The relative displacements observed for the remaining seven points after omitting these two are certain, being beyond the possible range of errors of observation.

The apparent absolute displacements for this group of points (see table 1 and map 25) indicate that all points on the eastern side of the fault moved in a southerly direction, and those on the western side in a northerly direction; that the displacements tend to be parallel to the fault, the more doubtful displacements showing the greater angles with the fault; and that the amounts of the displacement are in the inverse order of the distances of the stations from the fault, with two exceptions. These exceptions are San Pedro Rock, of which the relative displacement is determined with sufficient accuracy to establish this as a real exception; and Bonita Point Light-house, for which the apparent displacement as observed is so uncertain that this apparent exception has but little significance. Of the four points, all on the western side of the fault, of which the relative displacements are believed to be certain, as indicated in table 1, the azimuths of the displacements vary from 151° to 169°, with a mean of 157° (23° W. of N.). The azimuth of the fault in this vicinity is 144° (36° W. of N.).

The relative displacements on opposite sides of the fault and near to it are less in this group (2 to 3 meters) than for points at a similar distance from the fault in group 1; namely, Point Reyes Hill, Tomales Bay, and Bodega (5 to 6 meters).

*Group 4. Tomales Bay.* — There are seven points in this group (see tables 1 to 3 and maps 24 and 25). These were fixt in 1856-1860 by tertiary triangulation extending southeastward along Tomales Bay from stations Tomales Bay and Bodega of group 1. They were fixt again in practically the same manner in 1906 after the earthquake.

With these seven points may advantageously be considered the three points, Point Reyes Hill, Tomales Bay, and Bodega, which were fixt in group 1.

No one of these ten points was determined between 1868 and 1906, hence the observations served to determine the combined displacements of 1868 and 1906, as shown in table 3, but not the separate displacements. The separate displacements have been determined by interpolation from surrounding stations for the three points, Point Reyes Hill, Tomales Bay, and Bodega, as indicated in the discussion of group 1. The same process has also been applied to the seven points of group 4.

Starting *with*, the interpolated displacements of 1868 for the three points, Point Reyes Hill, Tomales Bay, and Bodega, as shown in table 2, and with map 25 before one, it was a simple matter to interpolate separately the meridian components and the prime vertical components of the displacements of 1868 for the seven stations of group 4. This amounts practically to interpolating the displacements for these points from the three observed displacements of 1868 at Mount Tamalpais, Farallon Light-house, and Ross Mountain. The resulting interpolated displacements of 1868 are shown in table 2. Each of these being subtracted, component by component, from the corresponding combined displacement of 1868 and 1906, as shown in table 3, leaves the displacement of 1906 as shown in table 1.

A study of the possible accumulated errors in the triangulations shows that all of the seven displacements of 1906 in group 2 are certain except for Hans and Hammond. There is about one chance in five that the apparent-displacements of 1906 for these two points are simply due to errors of observation.

The ten displacements of 1906 in this group show clearly the four laws already suggested in regard to such displacements. All points to the eastward of the fault moved southerly and those of the western side, northerly. Four of the five points to the westward of the fault moved in azimuths between  $141^{\circ}$  and  $143^{\circ}$  with a mean of  $142^{\circ}$  ( $38^{\circ}$  W. of N.). The azimuth of this part of the fault is about  $145^{\circ}$  ( $35^{\circ}$  W. of N.). The azimuth of the fifth displacement on the west side, at Bodega Head, is  $172^{\circ}$  ( $8^{\circ}$  W. of N.). The azimuths of the three reasonably certain displacements of points to the eastward of the fault vary from  $323^{\circ}$  to  $348^{\circ}$  with a mean of  $334^{\circ}$  ( $26^{\circ}$  E. of S.), which is within  $9^{\circ}$  of being parallel to the fault. Of the five points to the westward of the fault, the one nearest to the fault, Foster, has the greatest displacement. The other four, all between 2.0 and 2.7 kilometers from the fault, have nearly equal displacements. The five displacements for points to the eastward of the fault show a slight tendency to stand in inverse order from the distances from the fault. But one only of these displacements differs by more than 0.42 meter (1.4 feet) from the mean of the five, and the estimated distances from the fault vary only from 0.5 to 2.6 kilometers. When the uncertainty of the position of the fault beneath Tomales Bay is considered, as well as the small variation in distance of these ten points from the fault, difficulties are to be expected in detecting the relation between displacement and distance from the fault in this group. The mean displacement of the points to the eastward of the fault is 1.86 meters (6.1 feet) and of the five points to the westward 2.1 times as much, namely, 3.88 meters (12.7 feet).

*Group 5. Vicinity of Fort Ross.*—There are twelve points in this group, all determined by secondary triangulation in 1875-1876 and again in 1906, the scheme of triangulation being in each case substantially the same as that shown on map 25. The base from which these positions are determined is not independent of observations made before 1808, but is gotten by making the observations preceding that date conform to those made between 1868 and 1906. From the small size of the necessary corrections to the observed angles, and from the fact that the position of Ross Mountain, which predominates the group, is determined by observations made entirely after 1808, the error of assuming that these twelve points belong to the period between 1808 and 1900 is deemed negligible.

For one point, Chaparral, observations made in 1860 furnish a determination, of the position before 1868, and hence the displacement of this point in 1868 (see table 2) is determined as well as its displacement in 1906. The displacement of 1868 agrees closely, within less than 0.13- meter (0.4 feet) in amount and  $9^\circ$  in direction, with the displacement at that time at Ross Mountain, 5.7 kilometers (3.5 miles) to the eastward.

A study of the possible accumulated errors in the triangulation shows that five of the observed displacements in this group, as referred to Mocho and Mount Diablo, are clearly beyond the range of possible errors of observation; namely,, those at Fort Ross, Funcke, Timber Cove, Stockhoff, and Pinnacle Rock. For the remaining seven displacements, there are from one to two chances out of ten that they are due entirely to errors of observation, and these displacements are therefore reasonably certain. The relative displacements of pairs of points on opposite sides of the fault and near to each other in this group are certain, being in every case clearly beyond the range of possible errors of observation.

The apparent displacements in 1906 of the twelve points in this group conform closely to the four deduced laws governing such displacements. The seven points to the westward of the fault moved in a northerly direction, in azimuth varying from  $137^\circ$  to  $158^\circ$ , with a mean of  $144^\circ$  ( $36^\circ$  W. of N.). The azimuth of the fault in this region is about  $141^\circ$  ( $39^\circ$  W. of N.). All five points to the eastward of the fault moved southerly, in azimuth varying from  $301^\circ$  to  $328^\circ$  with a mean of  $318^\circ$  ( $42^\circ$  E. of S.). All of the points in this group are within 3.2 kilometers (2.0 miles) of the fault and therefore give little opportunity to ascertain whether the amounts of the displacements show any relation to distances from the fault. Such a relation is not clearly discernible among the observed displacements. The evidence of the apparent displacement at Ross Mountain (see table 1), 6.2 kilometers (4.2 miles) to the eastward of the fault, indicates a decrease of displacement with increase of distance from the fault in that direction. The average displacement of the five points to the eastward of the fault is 1.44 meters (4.7 feet) and that of the seven points to the westward is 1.5 times as great, namely, 2.11 meters (6.9 feet).

*Group 6. Point Ar&na.* — In this group there are ten points determined by secondary triangulation in 1870 to 1892 that were redetermined by secondary triangulation in 1906, starting from the stations Fisher and Cold Spring, 11.2 and 13.5 kilometers eastward from the fault respectively. (See map 25.) A study of the possible errors in the triangulation shows that all of the observed displacements in this group are certain, each being clearly greater than the maximum possible errors of observation. There is a possibility that the assumption that the two stations, Fisher and Cold Spring, remained unmoved in 1906 is in error. The movement, if any, of these stations was probably about the same for both stations and in a southerly direction and parallel to the fault. If such a movement of these stations occurred, the computed displacements in 1906, shown in table 1 and on map 25, are all too small for stations to the eastward of the fault, and too great for stations to the westward of it.

The agreement of the observed displacements of the ten points in this group with the four deduced laws is close. The six points to the westward of the fault moved in azimuths varying thru a range of  $5^\circ$  only, from  $159^\circ$  to  $164^\circ$ , with a mean of  $162^\circ$  ( $18^\circ$  W. of N.). The fault in this vicinity is said to change in azimuth, near the point where it crosses the coast-line, from about  $144^\circ$  to about  $164^\circ$  ( $16^\circ$  W. of N.), curving to the eastward. The four points to the eastward of the fault moved in azimuths varying from  $324^\circ$  to  $340^\circ$  with a mean of  $330^\circ$  ( $30^\circ$  E. of S.). The station Shoemake, comparatively near to the fault, 1.5 kilometers (0.9 mile), on the west side, showed a displacement much larger than any of the other five points on that side, all of which are from 5.7 to 7.6 kilometers from the fault. The two points to the eastward of the fault which are within less than 1 kilometer of it were displaced nearly twice as much as the other two which are nearly 4 kilometers from the fault. The average displacement for the four points to the east-

ward of the fault is 1.16 meters (3.8 feet) and for the six to the westward is 2.3 times as great, namely, 2.71 meters (8.9 feet).

*Group 7. Southern part of primary triangulation.*— In this group, extending southward from the line Mocho-Sierra Morena, there are nine points (see map 24) of which the positions were redetermined after the earthquake of 1906. Of these, one, Loma Prieta, had been formerly determined both before and after the earthquake of 1868; five others had been determined before 1868 but not after, and three had been determined after but not before 1868. (See tables 1 to 3.) In this group, therefore, but one point is available to show the displacement of 1868.

The triangulation of 1854-1855, starting from the line Ridge to Rocky Mound near the Pulgas Base, consisted of a single chain of triangles with all angles measured, down to the line Loma Prieta-Gavilan. The Point Pinos Light-house and the Point Pinos Latitude Station were connected with this chain, and with checks, by observations in 1854, 1864, and 1866.

The main triangulation of 1876-1887, from the line Mount Diablo-Mocho to the line Mount Toro-Santa Ana, consisted of a strong chain of figures with many checks, being substantially as shown on map 24 if Gavilan be omitted and all stations occupied. In this triangulation, however, no complete independent determinations with checks were made of Black Mountain, Santa Cruz Azimuth Station, Gavilan, Point Pinos Light-house and Point Pinos Latitude Station.

The triangulation of 1906-1907 was made as shown on map 24. Two separate least square adjustments were made of the main scheme connecting the points Mount Diablo, Mocho, Sierra Morena, Loma Prieta, Mount Toro, Gavilan, and Santa Ana.

In the first adjustment, it was assumed, as for the computations of other groups, that Mount Diablo and Mocho only remained unmoved during the earthquake of 1906. This first adjustment showed an apparent displacement of Santa Ana in 1906 of 3.26 meters (10.7 feet), in azimuth  $288^{\circ}$  ( $72^{\circ}$  E. of S.), but an examination in detail of the possible accumulated errors in the triangulation showed that this apparent displacement was probably due to errors of observation. The new primary triangulation is much weaker in the figure defined by the five points, Mocho, Loma Prieta, Mount Toro, Gavilan, and Santa Ana, than elsewhere for two reasons. First, the length must be carried without a check thru the triangle Loma Prieta, Mocho, Mount Toro, of which only two angles were measured and this triangle is very unfavorable in shape for an accurate determination of length. Second, it so happened that the least accurate observations made in the primary triangulation were in this triangle or in its immediate vicinity.

In the second and adopted adjustment it was assumed that Santa Ana, as well as Mount Diablo and Mocho, remained unmoved during the earthquake of 1906. The astronomic azimuth had been observed at Mount Toro in 1885 and again after the earthquake of 1906. These two observations measured the absolute change in azimuth of the line between Mount Toro and Santa Ana and indicated it to be 2.5", the later azimuth being the greater. This was utilized to strengthen the adjustment.

In view of the evidence of stations farther north, the assumption that Santa Ana remained unmoved is reasonably safe. Santa Ana is about 27 kilometers (17 miles) to the eastward from the point at which the fault disappeared near the village of San Juan. There is no station anywhere in the triangulation more than 6.4 kilometers to the eastward of the fault for which any displacement in 1906 was determined with certainty.

If Santa Ana was displaced in 1906, the erroneous assumption introduces an error into the computed displacements at the stations Gavilan, Mount Toro, Point Pinos Light-house, and Point Pinos Latitude Station, of about the same amount as the actual displacement at Santa Ana. The error produced in the computed displacement at Santa Cruz Light-house and Santa Cruz Azimuth Station must be much smaller, and no error

would be produced at Loma Prieta. Taking the uncertainty in regard to the estimated stability of Santa Ana into account as well as the possible errors in the triangulation, the following estimates of the uncertainties of the apparent displacements were made.

The displacements of Loma Prieta in 1906 and 1868 (see tables 1 and 2) are both certain.

The displacements of Black Mountain, Santa Cruz Azimuth Station, Gavilan, Point Pinos Light-house, and Point Pinos Latitude Station, as shown in table 3, are also certain. These are all combined displacements of 1868 and 1906. These stations were not determined between 1868 and 1906, hence it is not possible to determine directly from the observations the separate displacements. If it be assumed that the displacements in 1868 of the last four of these points were the same as that observed for Loma Prieta (see table 2), then the inferred displacements for each of these points in 1906 is as shown at the end of table 1. These inferred displacements for these points are, however, very doubtful as they depend upon a determination of the displacement of 1868 at a single point, Loma Prieta, which is 24 kilometers (15 miles) from Santa Cruz Azimuth Station and more than 48 kilometers (30 miles) from each of the other stations. It should be noted also that the displacement of Loma Prieta in 1868, which is certain, is very different from that of the other four points, Mount Tamalpais, Farallon Light-house, Chaparral, and Ross Mountain, for which the displacements of 1868 have been determined directly by observations. It is a displacement to the southward instead of to the northwestward and is much larger than for the other three points.

The determination of the displacement of Mount Toro as shown in table 1 is somewhat uncertain. There is still more uncertainty in regard to the apparent displacement at Santa Cruz Light-house.

The very small apparent displacement, 0.12 meter (0.4 foot), of the Lick Observatory small dome in 1906 is probably due to errors of observation.

The two points in this group to the eastward of the fault show apparent displacements in 1906 in accordance with the laws deduced from other groups: Lick Observatory, far from the fault, 36 kilometers (22 miles), having an apparent displacement so small as to be uncertain; and Loma Prieta, within 4.8 kilometers (3.0 miles) of the fault, having an apparent displacement of 0.97 meter (3.2 feet) in a southerly direction and within  $9^\circ$  of being parallel to the fault which here has an azimuth of about  $312^\circ$  ( $48^\circ$  E. of S.).

Mount Toro is the only station to the westward of the fault in this group for which a determination of the displacement of 1906 is not very doubtful. The displacement in 1906 of 0.95 meter (3.1 feet) at Mount Toro is in a northerly direction with a slight inclination to the westward in fair agreement with the deduced laws. Mount Toro is beyond the end of the portion of the great fault of 1906 which has been traced on the surface.

The apparent displacement of Santa Cruz Light-house in 1906, of which the determination is doubtful, is closely parallel to the fault and in a northerly direction, corresponding to other points to the westward of the fault.

The inferred displacements of 1906 for four points shown at the end of table 1 are all very doubtful, and little significance should be attached to them or to the fact that they are somewhat contradictory to each other and all have a southerly tendency, whereas all other points to the westward of the fault of 1906 moved in a northerly direction. As a check on this conclusion, it should be noted that the inferred displacement for 1900 for Santa Cruz Azimuth Station differs by  $72^\circ$  in direction and 1.26 meters (4.1 feet) in amount from the observed displacement of 1906 for Santa Cruz Light-house, a point only 3.9 kilometers (2.4 miles) away. The observed displacement for Santa Cruz Light-house is much less uncertain than the inferred displacement for Santa Cruz Azimuth Station and hence the contradiction throws additional doubt on the latter and the other three points for which the inference is made in like manner.



Tho the inferred displacements of these four points for 1906 are all very doubtful, the observed combined displacements of 1868 and 1906 for these four points, as shown in table 3, are all certain, being clearly beyond the possible range of errors of observation. So also are the combined displacements of 1868 and 1906 for Loma Prieta and Black Mountain. It appears then that the combined effects of the earthquakes of 1868 and 1906 were to move the whole region from Black Mountain to Point Pinos to the southeastward by from 2.11 to 5.89 meters (6.9 to 19.3 feet). The mean azimuth of these six displacements is  $321^\circ$  ( $39^\circ$  E. of S.). The most startling evidence of the combined effects of the two earthquakes is the increase of 3 meters (10 feet) in the width of Monterey Bay from Santa Cruz Azimuth Station to Point Pinos Light-house, both of these points having moved in a southerly direction, but the latter much more than the former. The length of the line Santa Cruz Azimuth Station to Point Pinos Light-house is only 39.8 kilometers (24.7 miles). The increase is therefore one part in 13,000.

Not much significance should be attached to the fact that Point Pinos Latitude Station has apparently moved one meter less than Point Pinos Light-house. This one meter is the difference of the combined displacements of two earthquakes. It is subject to the errors of observation in two determinations of each point by triangulation in somewhat different ways. Moreover, the determination of the position of the Latitude Station after the earthquake of 1906 was made without a check. It is for this reason that the displacement at Point Pinos Light-house is considered to be the more reliable determination of the two.

#### DISTRIBUTION OF EARTH MOVEMENT, SUMMARY.

In reaching the conclusions stated below, the evidence has been studied much more in detail than it has been given in the preceding pages. The conclusions are based on both the positive and negative evidence. The positive evidence is given by the displacements marked "certain" or "reasonably certain" in tables 1, 2, and 3. The negative evidence is given by displacements marked "doubtful," of which Rocky Mound is an example. At this point the observed apparent displacement of 1906 was only 0.34 meter (1.1 feet). The accuracy of the triangulation is such that it is practically certain that any displacement of this station as great as one meter would be detected. Hence the evidence given by this station is that the displacement, if any, was less than one meter and probably was less than 0.3 meter.

Maps 24 and 25 should be consulted while reading the following conclusions.

During an earthquake in 1868 or about that time, about 1,000 square miles of the earth's crust, comprized between the four stations Mount Tamalpais, Farallon Light-house, Ross Mountain, and Chaparral, were permanently displaced to the northward about 1.6 meters (5.2 feet), in azimuth  $169^\circ$  ( $11^\circ$  W. of N.). The indications are that this whole area moved as a block without distortion or rotation; at least the triangulation furnishes no evidence competent to prove either distortion or rotation of the block (about a vertical axis), or to locate accurately any boundary of the block. It is probable that the block included Sonoma Mountain. It is reasonably certain that Rocky Mound and the group of points near the southern end of San Francisco Bay, Red Hill, Pulgas Base stations, and Guano Island, were not on this block, tho they were probably displaced somewhat irregularly during the earthquake of 1868.

During the earthquake of 1868, or about that time, Loma Prieta was permanently displaced about 3.03 meters (9.9 feet), in azimuth  $307^\circ$  ( $53^\circ$  E. of S.). This displacement is in a direction at an angle of  $138^\circ$  with that of displacements of same date, referred to in the preceding paragraph. Loma Prieta moved to the southeastward, whereas Mount Diablo, Farallon Light-house, Ross Mountain, and Chaparral moved to the northward.

It is reasonably certain that Santa Cruz Azimuth Station, Point Pinos Light-house, Point Pinos Latitude Station, and Gavilan were similarly displaced. It is probable that the last

three stations named were displaced to the southeastward in 1868, being about 3 meters (10 feet) more than Santa Cruz Azimuth Station and Loma Prieta, and consequently the width of Monterey Bay was increased then by about one part in 13,000.

The combined effects of the earthquakes of 1868 and 1906 have increased the distance between Mount Tamalpais and Black Mountain, see map 24 and table 3, by 3 meters (10 feet). The distance is 79 kilometers (49 miles) and the increase is therefore one part in 26,000. The Golden Gate lies between these two stations. It is interesting to note that the length of part of the Pacific Coast including the Golden Gate has been increased just as the distance across Monterey Bay has been increased.

During the earthquake of April 18, 1906, displaced points on opposite sides of the great fault accompanying the earthquake moved in opposite directions, those to the eastward of the fault in a southerly and those to the westward in a northerly direction. Among all the points there are but two apparent exceptions to this rule, namely, Rocky Mound and Red Hill. For both these stations the apparent exceptional movement is so small as to be probably due simply to errors of observation and therefore it is not significant.

During the earthquake of 1906, the permanent displacements of all disturbed points were approximately parallel to the fault. When the difficulties encountered in determining the direction of these displacements are considered, it is remarkable that the observed displacements follow this law so accurately as they do. The nearest fixed points to which each displaced point is referred are from 30 to 140 kilometers distant (20 to 90 miles). The total displacements are from 0.5 to 4.6 meters (2 to 15 feet). Among all the points examined, there are but five for which the apparent changes in distance from the fault are not so small as to be probably due to errors of observation. The Farallon Light-house apparently moved at an angle of about  $27^\circ$  with the fault and its increase in distance from the fault of 0.8 meter is reasonably certain. As Mount Tamalpais, nearly opposite to Farallon Light-house across the fault, moved practically parallel to the fault, there was either an opening of the fault beneath the sea in this region or an increase in length of the earth's crust, in a direction at right angles to the fault, of one part in 50,000 (0.8 meter on 44 kilometers, or 3 feet on 27 miles). Point Reyes Light-house also apparently receded from the fault, moving in about the same direction (within  $5^\circ$ ) as the Farallon Light-house, but the determination of the displacement of the Point Reyes Light-house is so weak that this apparent displacement has little significance. It is reasonably certain that Bodega Head approached the fault from the western side, while Bodega, on the eastern side of the fault, about opposite, moved parallel to the fault. The apparent closing up of the fault or shortening of the crust at right angles to the fault is 1.6 meters (5.2 feet) between these two points only 5.4 kilometers (3.4 miles) apart. This is one part in 3,400. It is possible that as much as one-half of this apparent closing up is due to errors of observation, but it is reasonably certain that not all of it is due to that cause. Similarly it is reasonably certain that Peaked Hill in the Fort Ross group receded from the fault on the east side and Pinnacle Rock approached it on the west side, the apparent amounts being 0.4 meter (1.3 feet) and 0.7 meter (2.3 feet) respectively. It is reasonably certain that San Pedro Rock in the Colma group approached the fault from the west side, the apparent amount being 1.1 meters (3.6 feet).

During the earthquake of 1906, the displacements on each side of the fault were less the greater the distance of the displaced points from the fault. On the eastern side of the fault, ten points at an average distance of 1.5 kilometers (0.9 mile) from the fault have an average displacement of 1.54 meters (5.1 feet); three points at an average distance of 4.2 kilometers (2.0 miles) have an average displacement of 0.86 meter (2.8 feet), and one point, Mount Tamalpais, at 6.4 kilometers (4.0 miles) from the fault, has a displacement of 0.55 meter (1.9 feet). These fourteen points are the only ones on the eastern side of the fault for which the observed displacements were determined with reasonable certainty. For no point to the eastward of the fault at a greater distance than 6.4 kilometers (4.0

miles) was any displacement detected with certainty. To the westward, twelve points at an average distance of 2.0 kilometers (1.2 miles) from the fault have an average displacement of 2.95 meters (9.7 feet). Seven at an average distance of 5.8 kilometers (3.6 miles) have an average displacement of 2.38 meters (7.8 feet). The only other point to the westward of the fault of which the displacement was determined with certainty was Farallon Light-house, distant 37 kilometers (23 miles) and displaced 1.78 meters (5.8 feet).

In receding from the fault, either to the eastward or to the westward, the displacement decreases more rapidly near the fault than it does farther from the fault. According to the averages given in the preceding paragraph, the decrease in displacement on the eastern side near the fault is at the rate of 0.25 meter per kilometer (that is, 0.68 meter on 2.7 kilometers) and farther away the rate is 0.13 meter per kilometer (that is, 0.28 meter on 2.2 kilometers). Imagine a straight line before the earthquake of April 18, 1906, starting at the fault and extending eastward at right angles to it. According to this investigation, after the earthquake this line became a curved line concave to the southward, the point at the fault being displaced southward and distant points on the line remaining fixed. Also according to the above figures, the part of the line which is from 1.5 to 4.2 kilometers from the fault was deflected from its former direction about 52 seconds and that part from 4.2 to 6.4 kilometers from the fault was deflected about 26 seconds, and the deflection probably decreased gradually to zero at distant points. To the westward of the fault the rate of decrease of displacement, according to the averages in the preceding paragraph, near the fault is 0.15 meter per kilometer (that is, 0.57 meter on 3.8 kilometers), and farther away only 0.02 meter per kilometer (that is, 0.60 meter on 31 kilometers). Accordingly the imaginary straight line at right angles to the fault and extending westward from it has become concave to the northward, the point at the fault being displaced to the northward and very distant points remaining fixed. The deflection from its original direction is about 31 seconds for the part from 2 to 6 kilometers from the fault and about 4 seconds on an average for the part from 6 to 37 kilometers from the fault.

For points on opposite sides of the fault of 1906, and at the same distance from it, those on the westward side are displaced on an average twice as much as those on the eastern side. This statement applies especially to points within 10 kilometers (6 miles) of the fault. For points farther away, the ratio becomes more than two to one. It is important to note that this statement applies to displacements, not distortions. The distortion, expressed in angular measure, discussed in the preceding paragraph, is nearly the same on the two sides of the fault, being somewhat less close to the fault on the western side than on the eastern side.

The amount of relative displacement of the two sides of the fault by sliding along the fault, as detected by the triangulation, shows no variations for different parts of the fault along its whole length from Point Arena to San Juan, with one exception, which are sufficiently large to be clearly not due to errors of observation. This exception is the region near Colma where, as already noted, relative displacements seem to be unusually small.

The permanent displacements and distortions which took place at the time of the earthquake of April 18, 1906, may be pictured by imagining a series of perfect squares drawn on the surface of the ground before the earthquake, with their sides parallel and perpendicular to the fault. At the time of the earthquake every square to the eastward of the fault moved bodily in a southerly direction parallel to the fault, the squares more distant from the fault moving less than those near to it. All sides of squares parallel to the fault remained straight lines, unchanged in length and direction. For the squares to the eastward, the sides perpendicular to the fault became curved lines concave to the southward and changed direction as a whole by rotation in a counterclockwise direction, the change being 52 seconds or more for squares near the fault, and less for more remote squares\*. The angles of the squares all took new values differing from  $90^\circ$  by quantities

ranging from more than 52 seconds to zero. The squares to the westward of the fault were moved bodily in a northerly direction parallel to the fault, their sides parallel to the fault remaining straight and unchanged in length and direction. Their sides perpendicular to the fault became curved lines concave to the northward and each changed in direction by rotation in a counterclockwise direction, the change being more than 31 seconds for squares near the fault and less for more remote squares. The displacement of squares near the fault was twice as great for squares on the western side as for squares on the eastern, but the distortion was slightly less for squares on the western side than for those on the eastern side. The appreciable displacements extended back much farther from the fault on the western side than on the eastern side.

It is not probable that the actual displacements and distortions were perfectly regular as indicated in the word picture of the preceding paragraph, but the apparent departures from this perfectly regular ideal, of the displacements and distortions detected by the triangulation are nearly all so small as to be possibly due to errors of observation. Attention has been called to the few exceptions, of which one can be certain, which have been detected. The earth-movements of April 18, 1906, were remarkable for their regularity of distribution.

The triangulation of 1906-1907 has extended eastward clearly beyond the region of appreciable permanent displacements by the earthquake of 1906. The disturbed region evidently extended to the westward out under the Pacific beyond the possible reach of the triangulation. To the northward of Point Arena there is little probability of much success if an attempt were made to determine additional displacements by triangulation, for the known fault of 1906 touches the coast for but a short distance anywhere north of Point Arena, and triangulation to the northward of Point Arena before the earthquake consisted simply of a narrow and weak belt of tertiary triangulation. It had been intended to extend the triangulation of 1906-1907 far enough to the southward to reach outside of the disturbed region. It was supposed until after the observing party left the southern end of the triangulation that this had been accomplished, but when the additional evidence given by the office computations became available, it was evident that the most southern points determined are still within the disturbed region. The fact that the visible evidence of the fault of 1906 does not extend farther southward than San Juan indicates that there are probably few points to the southward of Mount Toro and Point Pinos for which the displacements were large enough to be detected by triangulation.

#### DISCUSSION OF ASSUMPTIONS.

Certain things have apparently been assumed in this investigation; for example, that appreciable permanent displacements occurred during the earthquake of 1868 as well as during the earthquake of 1906; that the permanent displacements in 1906 occurred suddenly, and that the stations Mocho and Mount Diablo remained unmoved in both earthquakes.

These are called apparent assumptions because in a real sense they are not assumptions but are instead facts detected gradually in studying for fifteen months upon a steadily increasing mass of evidence. However, treating them as assumptions, their validity has been reexamined in the light of all the evidence, and to make this report complete, it is now necessary to state why they are believed to be true.

It has been tacitly assumed that the permanent displacements of 1906, detected by the triangulation, took place suddenly. It is certain from evidence entirely distinct from the triangulation that on April 18, 1906, relative displacements by sliding along the great fault of that date took place suddenly, that is, within an interval of a few seconds, without much crushing or separation of the sides of the fault, and that these relative displacements;

amounted from 2 to 6 meters (7 to 20 feet). These relative displacements were evident at every road, fence, or line of trees crossing the fault, but such evidence does not enable one to ascertain how far back from the fault in each direction the displacement extended. The repetition of the triangulation after the earthquake showed that many points at various distances from the fault had all been displaced parallel to the fault, that the distribution of the displacements is regular, and that for points nearest the fault, the relative displacements corresponded in amount to those observed at roads; fences, tree lines, etc., at the fault and which were known to have taken place suddenly. Hence it is certain that the widely distributed displacements shown by the triangulation are a part of the same phenomenon and took place at the same time as the displacements at the fault, that is, suddenly on April 18, 1906.

For the displacements credited to the year 1868 in this report, the cases are different. It had been known from previous examination of the evidence given by triangulation that Mount Tamalpais had moved between 1859 and 1876. In the course of the detailed studies of the triangulation in connection with the present investigation, it was found that other triangulation stations had moved at or about 1868. It was discovered that wherever triangulation in this part of California before 1868 had been connected with triangulation done after 1868, it was necessary, in order to obtain consistent results, to apply abnormally large corrections to the observed angles. By trial it was found that wherever the observations of angles were separated into two groups and separate computations made connecting identical points marked upon the ground, one group comprising observations before 1868 and the other observations after that year, that the corrections necessary to obtain consistent results from each set of angles were much smaller than before, and about the normal size to be expected from the instruments and methods of observation used. The evidence proves that permanent displacements took place at or about 1868 of a magnitude which the triangulation could detect with certainty. The particular year in which the displacements took place is not fixed, however, by the triangulation, but simply the fact that they occurred within the interval of several years which elapsed in each part of the triangulation between the last observation before 1868 and the first observation after that year. For this reason considerable care has been taken in stating the dates of the triangulation for each locality. In 1906, it was known that sudden permanent displacements took place on a certain day, hour, and minute along a great fault-line and these displacements were similar to those detected later by triangulation. So far as the writers know, no evidence has been found that such large sudden relative displacements took place in 1868 or about that year, but it is known that a very severe earthquake in this region occurred in 1868. Hence the observed displacements, referred in this report to 1868 for the sake of brevity, may have occurred in some other year near 1868 and may have occurred by a gradually creeping motion extending over several years.

No other abnormal discrepancies in the triangulation within this region are known to exist. If there are such discrepancies, produced by displacements of the triangulation stations by earthquakes, they are so small as to be effectually masked by the unavoidable errors of observation. In other words, any other permanent horizontal displacements by earthquakes within this region between 1850 and 1907 must have been much smaller than the displacements of 1906 and 1868.

It has been assumed that there was no permanent displacement of stations Mocho and Mount Diablo during the earthquake of 1906. What is the evidence that this assumption is true?

The true direction or azimuth from Mocho to Mount Diablo was determined by observations upon the stars in 1887 and found to be  $144^{\circ} 57' 35.71''$ . In 1907 it was redetermined by observations upon the stars and found to be  $144^{\circ} 57' 35.66''$ , differing by only  $0.05''$ .

from its former value. The maximum possible difference between the two determinations of azimuth which could occur simply as errors of observation is about 1".<sup>1</sup> Hence these observations show positively that the true direction from Mocho to Mount Diablo had not changed between these dates by as much as 1" and probably had not changed by as much as 0.3".

The true direction or azimuth of the line Mount Tamalpais to Mount Diablo was determined by observations upon the stars in 1882 and again in the same manner in 1907. In 1882 it was found to be  $274^{\circ} 15' 15.04''$  and in 1907,  $274^{\circ} 15' 14.49''$ , 0.55" less than before. The azimuth of the line Mount Tamalpais to Mount Diablo was computed separately from the triangulation between 1868 and 1906, and from the triangulation after the earthquake of 1906 and the two values found to be  $274^{\circ} 15' 19.46''$  and  $274^{\circ} 15' 17.89''$  respectively, the second being 1.57" less than the first. This apparent decrease of azimuth as determined by the triangulation agrees within 1.02" with the decrease of 0.55" determined independently by astronomic observations.<sup>2</sup> This agreement is within the range of possible errors of observation. In the two computations of the triangulation, the line Mocho-Mount Diablo was assumed to have the same azimuth before and after April 18, 1906; hence the close agreement noted indicates that the azimuth Mocho-Mount Diablo remained unchanged.

In the investigation which has been made, it was found that the absolute displacement decreased with increased distance from the fault and that no displacement sufficiently large to be detected with certainty was found farther to the eastward of the fault than Mount Tamalpais, 6.4 kilometers (4.0 miles) from it. Mocho and Mount Diablo are 53 kilometers (33 miles) from the fault; hence it seems certain that the displacements, if any, at Mocho and Mount Diablo must have been extremely small. It may be objected that this is reasoning in a circle, inasmuch as the computed displacements depend upon the assumption that Mocho and Mount Diablo stood still. Cleared of this objection, the argument reduces to the following. The triangulation shows no relative displacements in 1906, large enough to be determined with certainty, of Mocho, Mount Diablo, Rocky Mound, Red Hill, and Lick Observatory, a group of points far to the eastward of the fault, whereas many points nearer to the fault showed large relative displacements as referred to each other, with a marked tendency to be greater the nearer to the fault are the groups of points compared. Hence the reasoning is valid that Mocho and Mount Diablo remained unmoved, these being two points in a group showing no displacements relative to each other, the whole group being far from the fault and these two particular stations being the two points most distant from the fault.

If either Mocho or Mount Diablo had moved in April, 1906, in such a direction as to decrease (or increase) the azimuth of the line joining them, the effect of the erroneous assumption, used in the computation of the triangulation done after the earthquake that the azimuth had remained unchanged, would have been to produce a set of computed apparent displacements which would be represented by red arrows on map 24, all indicating a rotation in a clockwise (or counterclockwise) direction around Mount Diablo, the lengths of the arrows being proportional to their distances from Mocho and Mount Diablo. The fact that the computed apparent displacements of 1906, as shown by the red arrows on maps 24 and 25, do not show any such systematic relation to each other, indicates that the line Mocho-Mount Diablo remained unchanged in azimuth on April 18, 1906.

<sup>1</sup> The probable error of observed azimuth in 1887 was  $\pm 0.21''$  and in 1907  $\pm 0.20''$ . The expression "probable error" is here used in the technical sense in which it is used in connection with the least square method of computation.

<sup>2</sup> The discrepancy of about 4" on each date between the azimuth determined by astronomic observations and the azimuth determined by triangulation is what is known as "station error" in azimuth and is due to the deflection of the vertical at the observation station. It does not enter into the present discussion, which is based on differences of azimuths of the same kind, either astronomic or geodetic, on different dates at the same station.

Similarly, if either Mocho or Mount Diablo had moved on April 18, 1906, in such a direction as to increase (or decrease) the distance between them, the effect upon the computations of apparent displacements would have been to produce a set of red arrows on maps 24 and 25, all pointing toward (or from) Mocho and Mount Diablo, the lengths of the arrows being proportional to their distances from Mocho and Mount Diablo. No such systematic relation appears among the arrows.

Another item of evidence is still available which indicates that the absolute displacement of points far to the eastward of the fault was zero on April 18, 1906. From 1899 to date a series of observations of latitude by observations upon the stars has been in progress continuously for the International Geodetic Association at Ukiah, California. The purpose of these observations is to detect variations in latitude due to any cause. The observations are of an extremely high grade of accuracy and they are made on every clear night. Dr. S. D. Townley, in charge of these observations, made a special study of the 233 observations made during the interval April 4-May 4 inclusive, 1906, to determine whether any sudden change of latitude took place on April 18.<sup>1</sup> He found no such change. The observations are competent to determine with reasonable certainty any change as great as 0.03", corresponding to 1 meter (3 feet). It is therefore reasonably certain that the southward component of the motion, if any, of the pier on which Dr. Townley's latitude instrument was mounted at Ukiah, was less than one meter on April 18, 1906. Ukiah is about 42 kilometers (26 miles) from the fault and to the eastward of it. Mocho and Mount Diablo are much farther from the fault (53 kilometers). It is important to note that latitude observations determined the absolute displacement rather than the relative displacement and that they are independent of observations at any other station.

For the reasons set forth above, it is believed to be certain that the permanent displacement, if any, of either Mocho or Mount Diablo on April 18, 1906, must have been extremely small.

During verbal discussions of the earthquake of April 18, 1906, it has been suggested more than once that one of its possible effects may have been to change the position of the earth with relation to its axis of rotation and so produce a change of latitudes. If an appreciable effect of this kind were possible, the validity of the above reasoning in regard to the latitude observations at Ukiah would be questionable. Accordingly, a computation of this possible effect has been made.<sup>2</sup> It was found that if it be assumed that the mass displaced in a northerly direction to the westward of the fault comprized 40,000 square kilometers (15,600 square miles) of the earth's crust, having a mean latitude of 38° and thickness or depth of 110 kilometers (68 miles), that this material had an average density of 4.0 and that the northerly component of the displacement was 3 meters (10 feet), the position of the pole of maximum moment of inertia would be displaced by 0.0007", corresponding to 0.002 meter (0.006 foot). This is a limiting value certainly much larger than the actual value, for all assumptions entering the computation as to the area, depth, density, amount of displacement, and mean latitude have been made such as to make the computed value certainly too great. Moreover, the similar displacements of contrary direction to the eastward of the fault would partially cancel those on the westward side which have been considered. When the pole of maximum moment of inertia is displaced, the pole of rotation is not immediately changed with reference to the earth. The pole of rotation tends always to seek the pole of maximum moment of inertia and travels around it in an irregular path. It is the instantaneous position of the pole of rotation with reference to the earth which fixes the latitude at any instant. Hence

<sup>1</sup> W. S. P. ^tigmatimii \*\* Published in the Publications of the Astronomic Society of the Pacific Vol. 4, No. 10, 1910, under the title The Latitude of the Ukiah Observatory before and after

<sup>2</sup> and method of computation is shown in *Traité de Mécanique Céleste*, par F. Tisserand, thier-Villars, Tome II, pp. 485-487.

even this extremely small displacement of the pole of maximum moment of inertia computed above, 0.002 meter, does not immediately affect the latitude of points in California, but only tends to change them by that average amount in the course of a year or more. The effect of the earthquake on the latitudes of points outside the region of actual displacement of the surface is therefore entirely negligible. The earthquake changed the latitude of marked points on the earth's surface within the disturbed region by the amount of the northward or southward components of the displacement of the points.

Similarly, the possible effect of the displacements on the deflections of the vertical, that is, upon the direction of gravity at any point, is too small to be considered.

The displacements near Point Arena were computed upon the assumption that the triangulation stations Fisher and Cold Spring remained unmoved during the earthquake of 1906. Is this assumption true? The station farthest to the eastward from the fault at which a displacement in 1906 has been detected with certainty is Mount Tamalpais, distant 6.4 kilometers and displaced 0.53 meter. Also the rate of decrease of displacements at this distance has been found to be 0.13 meter per kilometer of increase of distance from the fault. At this rate, the displacement would become zero at about 11 kilometers from the fault. Fisher is 11.2 and Cold Spring 13.5 kilometers from the fault; hence it is reasonably certain that if the displacement was not zero, at these two stations, it was so nearly zero that it could not have been detected with certainty.

A high degree of accuracy has been claimed for the triangulation. There is abundant evidence available from which to determine the actual accuracy, as has been indicated in an earlier part of this report. A large amount of time has been spent in studying this evidence in order to insure that the estimates of the accuracy of the determination of the various apparent displacements might be reliable. The methods necessarily followed in estimating the accuracy are too technical and too complicated to be included in this report. Two illustrations of the degree of accuracy attained in the observations may prove interesting, however.

The position of the Lick Observatory small dome was determined after the earthquake of 1906 by intersections upon it from four stations, Loma Prieta, Sierra Morena, Red Hill, and Mocho. There were discrepancies among these observations which were adjusted by the method of least squares and a resulting most probable position adopted and used in computing the apparent displacement given in table 1. The mean observation from Loma Prieta hit 0.38 meter (1.2 feet) to the left of the position adopted for the dome. The mean observation from Sierra Morena hit 0.22 meter (0.7 foot) to the right, that from Red Hill 0.01 meter (0.03 foot) to the left, and that from Mocho 0.11 meter (0.4 foot) to the left of the adopted position. The words "right" and "left" refer in each case to the Lick Observatory dome as seen from the station named. The distance of the four observation points from the Lick Observatory were, Loma Prieta 31 kilometers (19 miles), Sierra Morena 59 kilometers (37 miles), Red Hill 46 kilometers (29 miles), and Mocho 17 kilometers (11 miles).

Similarly the determination of the position of the Lick Observatory before the earthquake depended upon observations taken from seven stations, Santa Ana, Mount Toro, Loma Prieta, Sierra Morena, Mount Tamalpais, Mount Diablo, and Mocho. The line from Mount Tamalpais, 106 kilometers (66 miles) long, mist the adopted position by 0.36 meter (1.2 feet). The other six all came nearer than this to the adopted position.

The Farallon Light-house was determined between 1868 and 1906 by intersections upon it from three stations, Mount Helena, Mount Tamalpais, and Sierra Morena. The mean observation from Mount Helena, distant 112 kilometers (70 miles), mist the adopted position by 0.30 meter (1.0 foot) and the other two lines came closer. In 1906-1907 the Farallon Light-house was determined by intersections upon it from the six stations Ross Mountain, Tornaes Bay, Point Reyes Hill, Sonoma, Mount Tamalpais, and Sierra Mo-



rena. The line from Sonoma, 79 kilometers (49 miles) long, mist the adopted position by 0.10 meter (0.3 foot) and all the others came closer.

One other assumption remains to be examined. The displacements of 1868 were computed on the assumption that the line Mount Tamalpais to Mount Diablo had a certain length and azimuth before 1868 and a certain different length and azimuth after 1868; Mount Tamalpais being supposed to be in a new position, but Mount Diablo unmoved. The two positions for Mount Tamalpais *were* derived from certain computations based in turn on assumptions that certain other stations remained unmoved in 1868, or practically so.

The azimuth of the line Mount Tamalpais to Mount Diablo was determined by observations upon stars in 1859, and again in 1882; the later observations made the azimuth 7.84" greater than earlier observations. The two adopted azimuths from the computations of triangulation referred to above also differ by 5.38\*, the later adopted value being the greater.

The fact that the two independent determinations of change of azimuth, one astronomical and one geodetic, agree within 2.46" is a strong proof that the adopted geodetic azimuths are correct, 2.46" being within the possible range of the various observations.

Following the same reasoning as for Mocho and Mount Diablo, the computed displacements of 1868, as shown by red arrows on maps 24 and 25, indicate that the two azimuths and two lengths used for the line Mount Tamalpais to Mount Diablo, before and after 1868, must be very close to the truth.

#### CHANGES IN ELEVATION.

The preceding portions of this Report have dealt with permanent horizontal displacements caused by the earthquake of 1906. It is important to know whether permanent displacements in the vertical sense also occurred. Upon this point the observations of the Coast and Geodetic Survey furnish evidence for a small area, involving parts of San Francisco, both sides of the Golden Gate, and Sausalito, 1.25 miles north of the Golden Gate.

At the time of the earthquake an automatic tide-gage was in operation at the Presidio Wharf, in San Francisco, on the southern side and about 1.25 miles to the east of the narrowest part of the channel thru the Golden Gate. The gage had been in operation at that point continuously since July 17, 1897, and is still in operation.

The record made by this gage on April 18, 1906, showed an oscillation, with a range of about six inches, in the water surface evidently produced by the earthquake, but it showed no evidence of a change in the relation of the gage zero to mean sea-level. In other words, the record for that day does not indicate that the tide-staff had been changed in elevation by the earthquake.

To detect any possible small change in elevation it is, of course, necessary to examine much more record than that for a single day. The examination has now been extended by computation to include a whole year of observations since the earthquake for comparison with nine years of observations before it.

The following table shows the reading of mean sea-level on the fixed tide-staff for each of ten years, as determined by taking the mean of the hourly ordinates of the tidal curve. The annual means are taken rather than means for any other period in order to eliminate annual inequalities, presumably due to meteorological causes, which affect the means for separate months. May 1 is taken as the beginning of the complete year available after the earthquake. Since it is not convenient, in the computation, to separate any month's observation into two parts, the year is commenced on May 1, rather than on April *IK* the date of the earthquake. The first year, 1897-1898, is incomplete because the observations were not commenced until July 17, 1897.

Table 4. — Readings of Mean Sea-level on the Fixt Tide-staff.

PERIOD	READING OF MEAN SEA- LEVEL ON TIDE-STAFF	MEANS
	<i>Feet</i>	
July 17, 1897 to Apr. 30, 1898 . . . . .	8.339	8.318
May 1, 1898 to Apr. 30, 1899 . . . . .	8.298	
May 1, 1899 to Apr. 30, 1900 . . . . .	8.528	
May 1, 1900 to Apr. 30, 1901 . . . . .	8.550	8.520
May 1, 1901 to Apr. 30, 1902 . . . . .	8.430	
May 1, 1902 to Apr. 30, 1903 . . . . .	8.584	
May 1, 1903 to Apr. 30, 1904 . . . . .	8.509	8.652
May 1, 1904 to Apr. 30, 1905 . . . . .	8.667	
May 1, 1905 to Apr. 30, 1906 . . . . .	8.659	
May 1, 1906 to Apr. 30, 1907 . . . . .	8.631	

The ten annual means show an unmistakable tendency to fall into three groups, as indicated by the means shown in the last column of the table. Within each group there is no apparent tendency to increase or decrease. Between the first and second groups the reading of mean sea-level increased 0.202 foot and between the second and third groups, it again increased 0.132 foot. Such an increase corresponds to a subsidence of the zero of the tide-staff with reference to mean sea-level. An examination of the monthly means indicates that probably the subsidence occurred suddenly in each case, the movements taking place about June, 1899, and April, 1904. The record must not be considered as proving positively that these two subsidences took place. The changes are not clearly beyond the range of possible error in the determination of mean sea-level on account of irregular changes in the water surface due to causes not clearly understood, tho they are beyond the possible range of instrumental errors.

The annual mean for the one year after the earthquake, 1906-1907, agrees with the two preceding annual means within less than 0.04 foot. In no other case in the table do three successive annual means agree so closely with each other as these three. Apparently, therefore, no change in the elevation of the zero of the tide-staff occurred at the time of the earthquake.

As further evidence that no appreciable change in the elevation of the tide-staff took place on April 18, 1906, the following table is submitted. Corresponding months of two years, one before and one after the earthquake, are compared to avoid the effects of annual inequalities. The comparison indicates that no change took place in April, 1906.

Table 5. — Monthly Mean Readings of Mean Sea-level on Tide-staff.

	1905-1906	1906-1907	DIFFERENCE
	<i>Feet</i>	<i>Feet</i>	
May . . . . .	8.507	8.462	+ .045
June . . . . .	8.416	8.506	- .090
July . . . . .	8.668	8.688	- .020
August . . . . .	8.676	8.797	- .121
September . . . . .	8.648	8.632	+ .016
October . . . . .	8.690	8.442	+ .248
November . . . . .	8.751	8.295	+ .456
December . . . . .	8.479	8.625	- .146
January . . . . .	8.701	8.784	- .083
February . . . . .	8.877	8.725	+ .152
March . . . . .	8.934	8.944	- .010
April . . . . .	8.558	8.669	- .111
		Mean—	+ .028

The zero of the tide-staff was connected by leveling with the group of bench-marks near the gage at various times during the interval 1898-1907, including a determination after the earthquake. The leveling showed no appreciable change in the relation in elevation of the bench-marks and the tide-staff. Hence, the preceding statements in regard to a possible subsidence of the tide-staff on two occasions and in regard to its constancy of elevation on April 18, 1906, also apply to this group of bench-marks.

Before the earthquake the Coast and Geodetic Survey had done leveling which connected the gage at the Presidio Wharf with various bench-marks in San Francisco from Fort Point to the Union Iron Works, and with bench-marks at Sausalito. This leveling was not of the grade of accuracy known as precise leveling nor was it done continuously. There are also available for use in the present investigation certain relative elevations of bench-marks before the earthquake furnished to the Coast and Geodetic Survey by the city engineer of San Francisco. These include a bench-mark near the gage at the Presidio Wharf.

After the earthquake Mr. B. A. Baird, Assistant, Coast and Geodetic Survey, ran a line of precise levels from the Presidio gage to Fort Point and Sausalito, and to the eastward thru San Francisco, to the Union Iron Works, connecting with various old bench-marks.

There were 26 bench-marks connected by the leveling before the earthquake which were recovered with certainty by Mr. Baird and the elevations redetermined by him. The following table shows the elevations of these bench-marks before and after the earthquake and their apparent changes in elevations. All of the elevations in the table are referred to the same datum, which is the reading 8.514 feet (2.5951 meters) on the fixed tide-staff at the Presidio Wharf, that being approximately mean sea-level. All the elevations are computed on the supposition that the zero of the tide-staff at the Presidio Wharf remained unchanged at the time of the earthquake.

The table shows no appreciable change of elevation of the bench-marks at the Presidio Wharf. The maximum apparent change in elevation is 7.0 mm. (0.3 inch), a quantity within the possible range of error of the leveling. Mr. G. K. Gilbert, Geologist of the U. S. Geological Survey, at the close of an examination made soon after the earthquake and before the leveling had been done, expressed the opinion that if this group of bench-marks had not changed their relative elevations, they probably had not changed in relation to the tide-staff. It is probable, therefore, that these two bench-marks and the tide-staff maintained their absolute elevations unchanged.

At Fort Point, the three bench-marks near the shore show an apparent rise of 74 mm. (2.9 inches) on an average, and bench-mark 9, high up on Fort Point, shows a slightly smaller apparent rise, 59 millimeters (2.3 inches). All these are on ground supposed to be stable. The rise indicated by the city leveling, in the last column, is considerably smaller.

The two bench-marks at Sausalito show an apparent rise of 37 millimeters (1.5 inches). It is not certain that this represents a real change in elevation as referred to the zero of the Presidio tide-staff. The errors of the old and new leveling, including the crossing of the Golden Gate (about 1.25 miles) in each case, may account for the apparent change. In the leveling before the earthquake the elevation was transferred from Presidio to Sausalito by water-levels and also by wye leveling with a difference of 13 millimeters (0.5 inch). In the precise leveling after the earthquake, the two independent crossings of the Golden Gate, each depending on many hours of observation, differed by 30 millimeters (1.2 inches).

The three bench-marks at and near Fort Point showed small apparent changes in elevation.

From an examination made soon after the earthquake Mr. G. K. Gilbert, Geologist, expressed the opinion that the bench-marks at Lafayette Park were probably more stable

Table 6. — Elevations of bench-marks before and after the earthquake.

LOCALITY	CHARACTER OF BENCH-MARK	B.M.	ELEVATIONS			NEW-OLD (Coast and Geodetic Survey)	NEW-OLD (CITY)
			After Earthquake Coast and Geodetic Survey 1906-1907	BEFORE EARTHQUAKE			
				Coast and Geodetic Survey 1877-1905	City Levels 1901-1906		
			<i>Meters</i>	<i>Meters</i>	<i>Meters</i>	<i>Mm.</i>	<i>Mm.</i>
Presidio Wharf. ....	Zero of tide-gage	11	- 2.5951	-2.5951	.....	0.0	.....
	Hinge socket of door of brick warehouse.	12	3.8932	3.9002	3.9002	- 7.0	- 7.0
	Copper bolt in granite post.	15	2.7426	2.7371	.....	+ 5.5	.....
Fort Point .....	Copper bolt in natural rock.	4	6.7585	6.6797	.....	+ 78.8	.....
	Copper bolt in granite post.	5	14.7958	14.7237	.....	+ 72.1	.....
	Copper bolt in granite sea-wall.	6	3.9275	3.8554	3.8895	+ 72.1	+ 38.0
	Brass plate on con- crete emplacement.	9	60.7745	60.7151	60.7232	+ 59.4	+ 51.3
Sausalito. ....	Copper bolt in rock ...	2	1.3909	1.3564	.....	+ 34.5	.....
	Granite post .....	3	11.6073	11.5672	.....	+ 40.1	.....
Van Ness and Lom- bard Aves.	Star on iron plate in street.	27B	29.4047	.....	29.3967	.....	+ 8.0
Fort Mason .....	Granite post .....	28	32.5727	32.5606	32.5493	+ 12.1	+ 23.4
Fort Mason .....	Granite post .....	29	31.0876	31.0854	31.0649	+ 2.2	+ 22.7
Lafayette Park. ....	Granite post .....	24A	101.7846	.....	101.7412	.....	+ 43.4
	Pendulum pier. ....	25	113.9662	114.0414	.....	- 75.2	.....
	Transit pier. ....	27	115.3477	115.4222	.....	- 74.5	.....
Union Iron Works ...	Brass spike in brick bldg.	50	3.7860	3.8384	.....	- 52.4	.....
	Window shutter socket	47	4.4482	4.4004	4.4299	+ 47.8	+ 18.3
	Bolt in wall of bldg	48	6.2121	6.1695	.....	+ 42.6	.....
19th and Bryant Sts...	Copper bolt in brick bldg.	58	13.6176	13.5889	13.5883	+ 28.7	+ 29.3
Magdalen Asylum, Po- trero Ave.	Copper bolt in brick bldg.	61	23.3281	23.3063	23.2977	+ 21.8	+ 30.4
Appraisers' Bldg. .... Potrero Ave. and Divi- sion St.	Iron Rod .....	40B	3.3068	.....	3.3241	.....	- 17.3
	Fire hydrant .....	441	5.9000	.....	5.9695	.....	- 69.5
17th and Carolina Sts. Mariposa St. between Penn. and Iowa Sts.	Nail in doorstep. ....	City	6.0238	.....	5.9978	.....	+ 26.0
	Bolt in concrete on bridge over S. P. tracks.	S. P.	10.4666	.....	10.4110	.....	+ 55.6
Cal. and Montgomery Sts.	Water table of Parrott Bldg.	41	5.1488	5.0173	.....	+ 131.5	.....
East and Mission Sts.	Iron pillar of brick bldg.	43	2.4828	2.8523	.....	- 369.5	.....
Folsom between Main and Beale Sts.	Granite post set in brick wall.	44	5.4835	5.5516	.....	- 68.1	.....

than any of the others examined by him. The table indicates that the two of these bench marks, formerly determined by the Coast and Geodetic Survey leveling, subsided 75 millimeters (3.0 inches) and that the one, determined by the city leveling, rose 43 millimeters (1.7 inches). There is no apparent reason for the contradiction among the three bench-marks of this group.

For the three bench-marks at the Union Iron Works, the table shows a contradiction, two of them having, apparently, increased in elevation and one having decreased. The greatest change is, however, only 52 mm. (2.0 inches). The Union Iron Works is said to be partly on filled ground.

The two bench-marks near the Magdalen Asylum apparently increased in elevation as shown by both the Coast and Geodetic Survey and city leveling.

Of these bench-marks, the thirteen in the five groups at Fort Point, Sausalito, Fort Mason, Union Iron Works, and Magdalen Asylum, showed an average apparent rise at the time of the earthquake of 35 millimeters (1.4 inches) as determined by the Coast and Geodetic Survey leveling. As the leveling simply gives relative elevations the question arises, Does this quantity represent an average rise of the thirteen bench-marks or does it represent a settlement of the zero of the tide-gage and the adjacent bench-marks at the Presidio Wharf? The tidal observations are not competent to determine this question with certainty. The general experience with determinations of mean sea-level, from long series of tidal observations, warrants the statement that the error in determination from a single year is as apt to be greater as less than 0.75 inch (19 millimeters) and that it may sometimes be as great as 2.5 inches (64 millimeters). It is possible, therefore, that the two bench-marks at the Presidio Wharf and the zero of the tide-gage have settled 35 millimeters or that it is, in part, a subsidence at the Presidio and in part a rise at the other places.

The elevations of the group of four bench-marks in the table commencing with 40B at the Appraisers<sup>3</sup> Building, were determined before the earthquake by the city engineer, but not by Coast and Geodetic Survey leveling. These four, in various parts of the city, show no apparent change in elevation greater than 69 millimeters (2.7 inches). Two of them apparently rose and two subsided.

The apparent changes in elevation of the three bench-marks in the table, commencing with 41 at California and Montgomery Streets, are not supposed to have much significance in connection with the question of whether a general change of elevation took place. These three bench-marks were each subject to local disturbances during the earthquake or were near or on filled ground.

In ten cases the old leveling determined elevations of hydrants and the new leveling determined elevations on hydrants in the same locations but known, from the descriptions, to be different from the old hydrants. Similarly, in seven other cases, the old leveling established the elevations of points on curbstones, steps, or doors, and in each of these cases in the new leveling it was found to be impossible to recover the old point accurately. In all of these 17 cases there is, therefore, only an approximate connection between the old and the new leveling. The evidence from these bench-marks has all been examined carefully and does not lead to any different conclusion from that which may be drawn from the table above.

The general conclusion from both the leveling and the tidal observations is that, within the region examined, there occurred no general change of elevation of sufficient magnitude to be detected with certainty.

It is an opportune time, at present, on account of local changes in elevation at various bench-marks, to adopt the best possible determination of mean sea-level which is available up to date and to refer all new elevations determined since the earthquake to that datum. Accordingly, the reading 8.652 feet (2.7371 meters) on the tide-staff at the Pro-

sidio, given in column 5 on page 143 which is the mean for the three complete years, May 1, 1904, to April 30, 1907, is adopted as being mean sea-level. The values given in column 4 of the table on page 143 are referred to the reading 8.514 feet (2.5951 meters) as mean sea-level. Hence, a correction of  $-0.138$  foot ( $-0.0420$  meter) should be applied to these values to obtain the elevations now adopted as best.

It is uncertain, as already indicated in this report, whether this correction of  $-0.0420$  meter is due to improvement in the determination of the relation of mean sea-level to the tide-staff or to a subsidence of the tide-staff and adjacent bench-marks in 1904 or earlier, or to both.

## NOTE ON THE COMPARISON OF THE FAULTS IN THE THREE EARTHQUAKES OF MINO-OWARI, FORMOSA, AND CALIFORNIA.

BY F. OMORI.

The three great earthquakes of Mino-Owari (Central Japan) on October 28, 1891, of Kagi (Formosa) on March 17, 1906, and of California on April 18, 1906, were each accompanied by the formation of remarkable geological faults, whose total lengths were about 100, 50, and 430 kilometers respectively. The dislocation in the California earthquake was formed partly along, and partly off, the coast of California, belonging to the category of longitudinal faults.

The dislocation in the Mino-Owari and Kagi earthquakes were, on the other hand, formed nearly at right angles to the course of the Main Island (Nippon) and the axis of Formosa Island respectively, both belonging to the category of transverse faults.

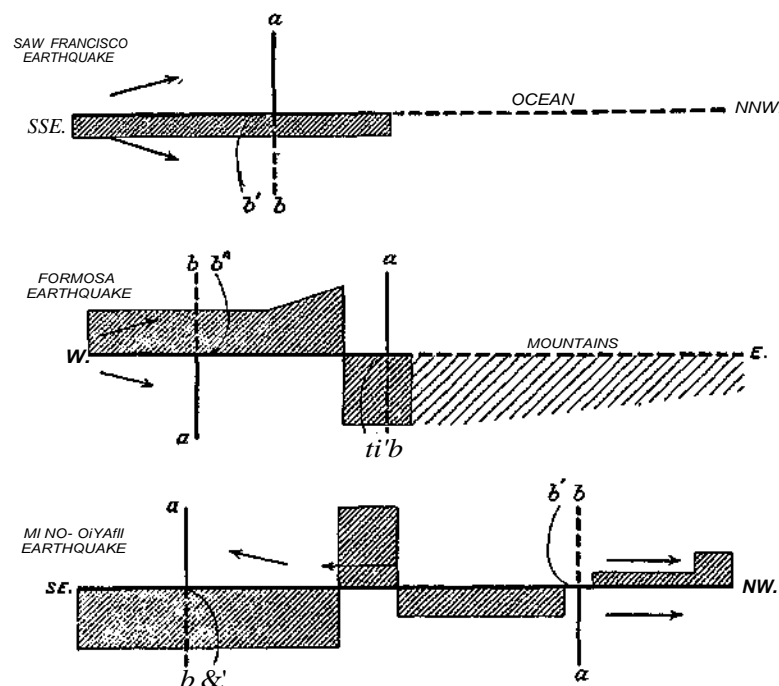

FIG. 43 a. — Full line is fault (ascertained). Shaded part is depressed region. Dotted line is probable continuation of fault. Lightly shaded part represents probable depression. Arrow indicates the direction of maximum (vibratory) motion.

Notwithstanding these differences, there are certain similarities among the three cases. Thus, in each of the three earthquakes, the direction of motion at different places in the immediate neighborhood of the fault was not perpendicular, but more nearly parallel, to the strike of the latter. This seems to indicate that the formation of the faults was mainly due, in each case, not to such actions as a simple falling down or sudden creation of a cavity underground, but to the existence of shearing stresses in the plane of fracture possibly of two opposing forces acting either from the center toward both ends of the fault-line, or toward the center from both ends.

The accompanying figure is a diagrammatic illustration of the three faults, the line  $ab$  indicating, in each case, a straight line (say, road) which suffered a shearing movement in such a way that the part  $b$  on the depressed side was displaced to the new position  $b'$ , and generally transformed into a curve.

From the figure it will be seen that there existed in each fault what may be called the *central point*, where the disturbance of the ground is greatest and about which the shear and depression along the line of dislocation is more or less symmetrical. In the case of the Mino-Owari earthquake the central point was in the vicinity of the village of Midori in the Néo-Valley, where a very remarkable depression of the ground took place. The corresponding point on the Formosa fault was between the villages of Bishō and Kaigenkō. In the California earthquake the northern half of the fault was in part under the ocean, but the central point was probably in the vicinity of the Tomales Bay, the greatest amount of disturbance having occurred there.

The greatest vertical dislocation of 18 feet occurred in the Mino-Owari earthquake, while the greatest horizontal shear occurred in the California earthquake. In the latter the vertical displacement was only 1 or 2 feet, while in the former there was also a large horizontal shear of about 18 feet. In the Formosa earthquake, whose magnitude was much smaller than the other two, the vertical and horizontal displacements of the ground were each of a moderate scale, the maximum amounts being 6 and 8 feet respectively. The maximum (vibratory) motion in the Mino-Owari earthquake showed a tendency of being directed from the central point toward each end; while, in each of the two other earthquakes, the same motion was, as far as can be ascertained, directed from one end toward the center. Again, the direction of the maximum (vibratory) motion was, in the Formosa earthquake, the same as that of the shear of the depressed ground. In the two other earthquakes, however, the reverse was the case. These differences are probably due to the variation in the manner of the action of the force along the fault-plane which finally produced the dislocations.

---

#### REVIEW OF SALIENT FEATURES.

The differential displacement of the earth's crust effected by the movement on the San Andreas fault on April 18, 1906, may for convenience be resolved into two components, the horizontal and the vertical. Of these the horizontal movement was the more important and was susceptible of measurement, giving minimum values for the amount of displacement in this direction practically all along the trace of the fault, except at the extreme north and extreme south. The vertical movement was small compared with the horizontal, and was established satisfactorily only in the region to the north of the Golden Gate.

Two kinds of evidence of vertical displacement were available. The first of these was the formation of scarps along the fault-trace, and the second was the change on portions of the coast of the level of the land relatively to sea-level. The scarps that appeared as features of the fault-trace were in part fresh facets where none had existed before the earthquake and in part accentuations or additions to old scarps due to former movements. In both cases exact measurements were rendered difficult by the drag of the soil along the rupture, and by the complication due to the larger horizontal movement. But making all allowances for the masking effect of drag of the soil, it is certain that the height of these scarps, or of the additions to old ones, was quite variable, even in the same general locality, within a range of a few inches up to about 3 feet. It is suggested that this variation is referable in considerable measure to the drag and adjustment of materials in the zone beneath the soil; so that the true displacement of the firm rocks lies between, the extremes observed.

The evidence of vertical displacement, based on the recognition of scarps, indicates a slight upward movement of the crustal block on the southwest side of the fault in the northern territory. South of the Golden Gate there is no very satisfactory or consistent



evidence of differential vertical movement. For many segments of the fault-trace in this region, there is no suggestion of displacement of this kind. In other portions, notably in the vicinity of Black Mountain and southward, the movement appears to have been distributed over a considerable zone, with the formation of many auxiliary cracks. Upon the latter scarps were formed, but these in some cases faced the northeast and in others the southwest, and the resultant effect is not known. Judging from the localities where the movement was not so distributed, but was confined to a narrow zone, the differential vertical displacement was nil.

Similarly, the evidence of vertical displacement, based on a comparison of the relative position of land and sea-levels before and after the earthquake, is limited to the region north of the Golden Gate. The Point Reyes Peninsula appears, from this class of evidence, to have been probably upraised slightly by the fault movement; but the evidence is not entirely conclusive.

Observations conducted by the Coast and Geodetic Survey thruout the year succeeding the earthquake, at the tide-gage station near Fort Point in the Golden Gate, show that the relative level of land and sea at that point is the same as it was before the earthquake. Since this station lies on the northeast side of the fault, the observation would appear to indicate that any upward movement of the crustal block on the southwest side was an absolute one.

The horizontal displacement on the fault, as measured on fences, roads, and various structures which cross the fault-trace, is also apparently quite variable, ranging from a foot or less up to 20 or 21 feet. This variation is probably due to a number of causes. The principal one of these is the fact that the displacement was not always confined to the sharp line upon which an offset was observed at any locality. Auxiliary cracks, distributed over a zone not uncommonly a few hundred feet wide, took up portions of the displacement; and these auxiliary cracks doubtless escaped observation in many cases. Indeed, owing to the yielding character of the superficial mantle of soil and regolith, it is probable that many of these auxiliary cracks did not appear as ruptures at the surface. Besides this distribution of the displacement on auxiliary cracks satellitic to the main rupture, the deformation of the ground along the latter, both superficially and in its deeper portions, was probably variable. The extent of this drag is shown in a few instances that have been susceptible of measurement; notably the fence at Fort Ross, surveyed by Mr. E. S. Larsen, on which a displacement of 12 feet was distributed over a distance of 415 feet on the southwest side of the fault-trace; the roadway near Point Reyes Station, where a displacement of 20 or 21 feet was distributed over 60 feet; the fence south of Mussel Rock, surveyed by Mr. H. O. Wood, in which a displacement of 13 feet was distributed over 250 feet on the southwest side of the fault-trace and 40 feet on the northeast side; the 3 fences surveyed by Mr. R. B. Symington near San Andreas Lake, one showing a displacement of 10.9 feet, distributed over more than 1,100 feet, the second a displacement of 10.4 feet distributed over more than 300 feet, and the third a displacement of 12.7 feet distributed over more than 2,200 feet; and the tunnel at Wright, surveyed by the engineers of the Southern Pacific Company, showing a displacement of 5 feet distributed over nearly a mile on the southwest side of the fault-trace. These instances are doubtless indicative of the general character of the deformation of the ground in the immediate vicinity of the fault, and aid in understanding the variable expression of the amount of offset at the main fault-trace. The recognition of the distribution of the movement on auxiliary cracks, some of which may not have appeared at the surface, and the deformation of the ground along the zone of rupture, justifies the conclusion that, except under peculiar conditions — such, for example, as in the marsh at the head of Tomah's Bay — the maximum figures obtained for the displacement by the measurement of offsets at the surface must be a minimum expression for the true extent of the

movement in the firm rocks below. For the middle half of the extent of the fault-trace from Point Arena to Crystal Springs Lake, these maximal measurements are very commonly from 15 to 16 feet, and these figures may thus be taken as a minimum expression for the amount of the displacement on the fault for this segment. In the southern quarter of the extent of the fault-trace, the maximum offset is about 8 feet, and this may similarly be taken as a general minimum expression for the displacement on this segment, except for the extreme south end, where it dies out. The amount of displacement at the northern end of the fault has not been ascertained.

The geodetic measurements of the earth movement, as presented in the paper by Messrs. Hayford and Baldwin, are of extreme interest and form one of the most important contributions to the study of the earthquake. The evidence of displacement observed along the fault-trace affords measurements of the total relative movement only, while the geodetic work gives us an approximate measure of the absolute movement on either side of the fault, and the distribution of the movement away from the fault. The results of this geodetic work are not only set forth in detail by the paper of Messrs. Hayford and Baldwin, but they are also admirably summarized, so that all that seems necessary in this place is to discuss very briefly these results from a geological point of view.

A notable feature of the paper is the discovery of a movement of the earth's crust which antedates the earthquake of April 18, 1906, and which is referred to the earthquake of 1868; altho it is recognized that the date and duration of the movement cannot, on the data available, be positively determined. Inasmuch as the time of this movement is left an open question, and is referred to the year 1868 largely as a matter of convenience in discussion, it may be of advantage to inquire briefly whether or not it may have some other significance than that of a sudden movement occurring in that year.

Altho, as shown in another part of this report, the earthquake of 1868 was related to a rupture or series of ruptures of the ground at the base of the hills on the northeast side of San Francisco Bay, there was no evidence of a large relative displacement such as occurred in 1906. It seems reasonable to suppose that if the earlier movement in question had occurred suddenly in the same way as that of April 18, 1906, we should have had a similar manifestation of faulting within the region affected. Since there was no such manifestation the reference of the earlier movement to the earthquake of 1868 may be fairly questioned, and another hypothesis entertained to explain it, particularly if this hypothesis harmonizes in some considerable measure with the results of the geodetic survey.

This hypothesis is that the earlier movement is not immediately or exclusively associated with the earthquake of 1868, but is the expression of the strain in the earth's crust which led to the rupture or slip of 1906 and the consequent earthquake. That rupture presupposes a condition of strain, and it is difficult if not impossible to conceive of such a sudden disruption except as a relief from strain. Such strain involves the idea of slow displacement; and if a series of points had been established in the territory affected at different dates, with reference to some base beyond it, a measure of this slow displacement or creep of the earth's crust might have been obtained.

The strain culminated in a slip on an old rupture plane and may fairly be supposed to have been more or less symmetrically distributed with reference to that plane, so that; when relief was effected by slip, the movement involved would be equal in amount on the two sides of the fault.

This hypothesis and its implications appear to fit fairly well with the results of the geodetic resurvey, particularly for that portion of the territory where the earlier movement can be most satisfactorily discriminated from the displacement of 1906. For example in the Tomales Bay region there are ten points, viz.: Bodega Head, Tomales Point, Tomales Bay, Foster, and Point Reyes Hill on the west side of the fault of 1900, and Bodega, Smith, Mershon, Hans, and Hammond on the east, at which the two move-

ments are separated. These stations are found to have moved in a nearly north direction an average amount of 1.56 meters in the interval between "before 1868" (1856-1860) and "after 1868" (1874-1891). Since the values upon which this average is based were arrived at in part by methods of interpolation, there is no great variation from the average at any of the ten stations. The interval within which this northerly movement took place is rather indeterminate, but may be placed doubtfully at 32 years.

Under the hypothesis here presented this movement continued at a probably uniform rate for the next 16 years up to the time of the earthquake of 1906. This would give us a total northerly movement for the interval from 1856-1860 to 1906 of 2.34 meters. Now the northerly component of the combined earlier and 1906 movements, shown in table 3 of Hayford and Baldwin's paper, is on an average 4.95 meters for the five stations west of the fault-line. This includes the sudden movement of 1906 plus the slow creep of 2.34 meters above deduced. The value for the northerly component of the sudden movement of those points in 1906 is thus  $4.95 - 2.34$ , or 2.61 meters. Similarly the southerly component of the combined movements for the five stations to the east of the fault is found to be on the average 0.09 meters. The southerly component of the sudden movement of 1906 was therefore  $0.09 + 2.34$ , or 2.43 meters. The absolute movement on the two sides of the fault on April 18, 1906, was thus nearly the same in amount.

The reference of the earlier movement to a slow creep thus appears to harmonize with and therefore tends to confirm the *a priori* assumption that the absolute movement of 1906 should have been the same on both sides of the fault. Were data available as to the time at which other groups of stations were determined in position, it is probable that a similar result would be reached. We may consider, therefore, that the earlier movement is better explained on the hypothesis of slow creep, continuing up to April 18, 1906, than on the assumption that it occurred at or about the time of the earthquake of 1868. This conclusion applies to the region north of San Francisco Bay. To the south of the Bay the data available are inadequate for a satisfactory separation of the two movements, except in the case of Loma Prieta, and here the earlier movement appears to have been southerly.

Another result of the geodetic resurvey which points to a slow creep of the region under strain precedent to April 18, 1906, is the distribution of the displacement on that date. The measurements of the absolute displacement on the two sides of the fault show that it was notably greater near the fault than at points remote from it. Thus if we imagine a series of points in a straight line transverse to the fault before the earthquake that line was so deformed that the segment to the west of the fault curved northerly and the segment to the east curved southerly in approaching the fault-trace. This deformation can be most readily explained by supposing that the series of points upon the assumed straight line were determined as to position in the first instance upon the surface of a portion of the earth under elastic strain, so that when relief was effected by rupture, the points tended to assume positions relative to one another which they would have had if they had been determined before the advent of the strain.

It may be further pointed out that the conclusion reached by Hayford and Baldwin to the effect that the absolute movement on the west side of the fault was on the average twice as great as the movement on the east side is founded on the assumption of the stability of the base-line Diablo-Mocho. In view of the unknown extent of the earth movement of April 18, 1906, it would seem preferable to make the assumption that the relief from strain was approximately distributed equally on the two sides of the fault and from this infer the amount of the southeasterly displacement of Diablo and Mocho. The assumption that Diablo and Mocho were not affected by the disturbance of April 18, 1906, is based on the following considerations:

1. There was no change in the azimuth of the Diablo-Mocho line.
2. There was no change in the length of that line.
3. There was no appreciable change in the relations of these two stations to certain others nearer the fault.
4. The latitude of Ukiah remains the same as before the earthquake.

The first three of these conditions would be fulfilled if the region including all the stations occupied had moved in unison southeasterly with but little or no rotation, a possibility which it is difficult to deny. The fourth consideration does not preclude this possibility since the amount of movement involved is probably less than the errors of the method used for the determination of the latitude of Ukiah.

In the region about Monterey Bay the most interesting fact brought out by the geodetic resurvey is that the combined effect of the earlier movement and that of 1906 is a southerly migration of the earth's crust on both sides of the San Andreas rift. It is probable from direct observations of relative displacement along the fault-trace in 1906 that the southwesterly block moved northwest as far as the rupture extended. If this be accepted, then the southerly net movement on the west side of the south end of the fault is due to the predominance of an earlier southerly movement. This agrees with the positive and certain earlier displacement of Loma Prieta. Accepting the southerly character of this earlier movement as certain, there is forced upon us the remarkable fact that the direction of displacement in the region about Monterey Bay is the reverse of that of the earlier movement for the region north of San Francisco Bay. This means that the earlier movement was distensive in character, displacing the territory to the north of San Francisco Bay northerly, and that to the south southerly while the vicinity of the Bay itself was relatively neutral. It appears, moreover, that the southerly displacement was differentially diffused, since the amount of displacement of the south side of Monterey Bay was notably greater than that of the north side, resulting in a widening of the Bay by about 10 feet.

Similarly the distance between Tanralpais and Black Mountain, both on the same side of the San Andreas rift, has been increased by a like amount. The significance of this general distension involved in the reversal of the direction of displacement to the north and south of San Francisco Bay, and of the differential character of this distension, without known rupture, at Monterey Bay and San Francisco Bay, can not at present be stated. The problem requires prolonged study and repeated measurements to secure the necessary data for a proper discussion. It is evident, however, that we are here confronted with some of the most interesting phenomena in the mechanics of the earth's crust, phenomena which call for deliberate investigation extending through years and decades and conducted on a wisely planned program.

## PROVISION FOR MEASUREMENT OF FUTURE MOVEMENTS ON SAN ANDREAS FAULT.

The extent of the movement on the San Andreas fault on April 18, 1906, was measured imperfectly and inexactly by offsets of fences, lines of trees, roads, pipes, dams, creeks, shore lines, etc. The distribution of the displacement in the immediate vicinity of the fault, the drag and compression of the soil, the uncertainty as to the former orientation of the lines offset, and other adverse conditions rendered the determinations unsatisfactory to a certain degree. With one exception, the measurements obtained in this way are suspected of being less than the true amount of relative displacement of the firm rocks below the surface materials.

With the object of obtaining a more exact measurement of any future movements that may take place on the same fault, the Commission caused to be established two sets of piers or monuments in the Rift, in proximity to the fault-trace, upon which instrumental observations could be obtained as to the amount of displacement. This was not done in anticipation of the recurrence of a large movement in the near future, but because it was suspected that there might be slight movements at the times of minor earthquakes, such as are fairly common. Such slight movements might, in the course of years, accumulate to an important amount, and yet the individual increments of the displacement escape notice unless refined methods of measurement are resorted to. It is hoped that the establishment of the monuments and the redetermination of their relative positions from time to time will enable future observers to ascertain whether or not there is a small progressive movement on the San Andreas fault, in addition to the larger movements which cause more violent earthquakes, such as those of 1857 and 1906. Besides serving this purpose, the movements will also be useful in any effort that may be necessary in future to determine with precision the amount of a large displacement.

The localities selected for the position of the two sets of monuments are Olema, Marin County, and Crystal Springs Lake, San Mateo County. These localities are about 40 miles apart on the Rift, and the fault-trace at both was confined to a very narrow zone in 1906, thus permitting the piers to be more closely grouped than at many other localities which for other reasons might have been chosen.

Each set of monuments consists of four concrete piers, established two on each side of the fault-trace of 1906. They are sunk in the ground to a depth of about 6 feet, and are founded either upon rock or upon a firm "hard-pan" arising from the decomposition of the underlying rocks. They rise from 2 to 3 feet above the surrounding surface. The establishment of the piers at Olema was intrusted to Mr. A. J. Champreux, of the Astronomical Department of the University of California, and those at Crystal Springs Lake were set in place by the officers of the Spring Valley Water Company, under the direction of its chief engineer, Mr. Hermann Schussler, who very kindly relieved the Commission of any expense connected with the operation. The piers at Olema are 13 inches square in cross-section, while those at Crystal Springs Lake are 18 inches square. To the summit of each of the piers is fixed a thick bronze plate 13 inches square, with suitable appliances for receiving a selected instrument in a constant position for successive measurements, and a device for determining a fixed point to which to measure. This plate is protected by a heavy iron cap, 14.5 x 14.5 inches, locked upon it, bearing the inscription:

S.E.I.C.  
To measure  
earth movements  
1906.

The instrument selected for the first and subsequent measurements is a 10-inch alt-azimuth, the property of the University of California, and the key of the protecting caps is at present in the safe keeping of the same institution.

In order to render the monuments thus established available for future measurements of displacement, it was necessary to have their present relative positions established with precision. This work was very kindly undertaken for the Commission by Mr. B. A. Baird, Assistant, Coast and Geodetic Survey, a report from whom follows, setting forth his methods and results:

#### RELATIVE POSITIONS OF THE MONUMENTS.

By B. A. BAIRD.

OLEMA.

*Description of monuments.* — The monuments at Olema are on Mr. Skinner's ranch, just a little north of the dwelling-house. The two piers west of the fault-trace are in an orchard on level ground, but the other two, which are just east of the road, are on a hillside, the northeast monument being about 15 feet higher than any of the others. In order to measure and observe between the northwest monument and the southeast monument, a trench about 3 feet deep had to be dug thru the embankments on both sides of the road and somewhat into the traveled portion as well. Some clearing of brush was necessary in order to make the northeast monument and the southwest monument intervisible.

The relative positions of the four monuments are shown in the diagram, fig. 44. The lengths of the three heavy lines were determined by measurement. The measurements of the other three lines were considered impracticable, on account of the great height of the northeast monument above the others, as compared with the short distances between them and it. By means of the three measured lines, however, a double determination is obtained, thru the observed angles, of each of the three lines not measured by the steel tape.

The lines were cleared sufficiently so that all four of the monuments could be occupied with a theodolite, and then all of the lines were observed, including the diagonals. In order that future movements may be readily detected by means of observed angles, the centering of the instrument was considered to be of the greatest importance, especially for such very short lines as these. A bronze plate had been constructed and set up on each monument, especially designed for supporting in position the Fauth 10-inch alt-azimuth instrument of the Civil Engineering Department of the University of California.

A sketch of the plate is shown in fig. 45. The spindle which screws into the central socket of the plate is shown in fig. 47, and the iron cap which protects the plate when the spindle is removed is shown in fig. 46. Referring to the sketch of the plate, it will be seen that there are three lugs, or foot-plates, standing upon and attached to it. In one is a groove (vertex of angle at bottom), and in one a hole (inverted cone), while the third has simply a smooth surface. This arrangement prevents any binding of the foot-screws of the instrument, and insures that it will always be set in the same position in successive measurements.

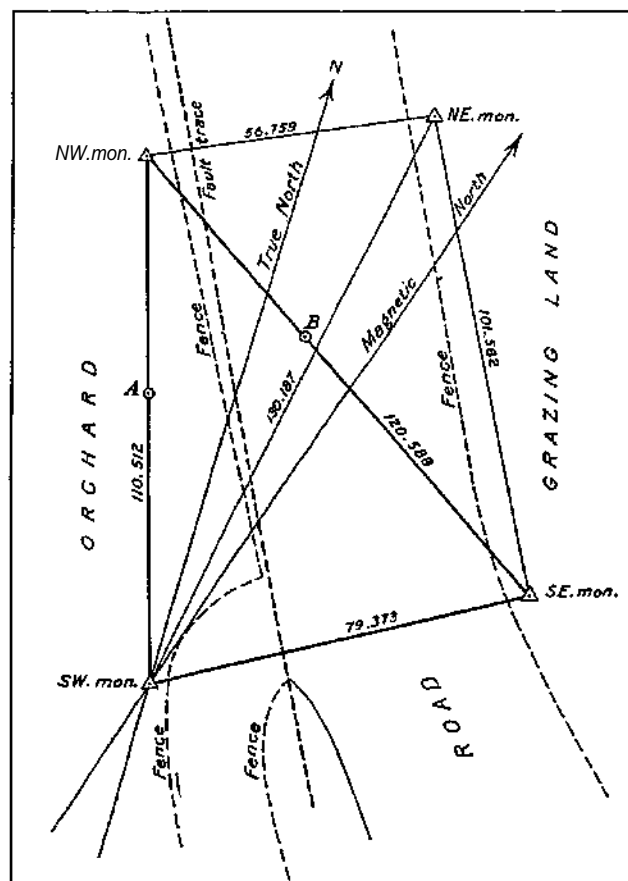

FIG. 44. —Monuments at Olema.

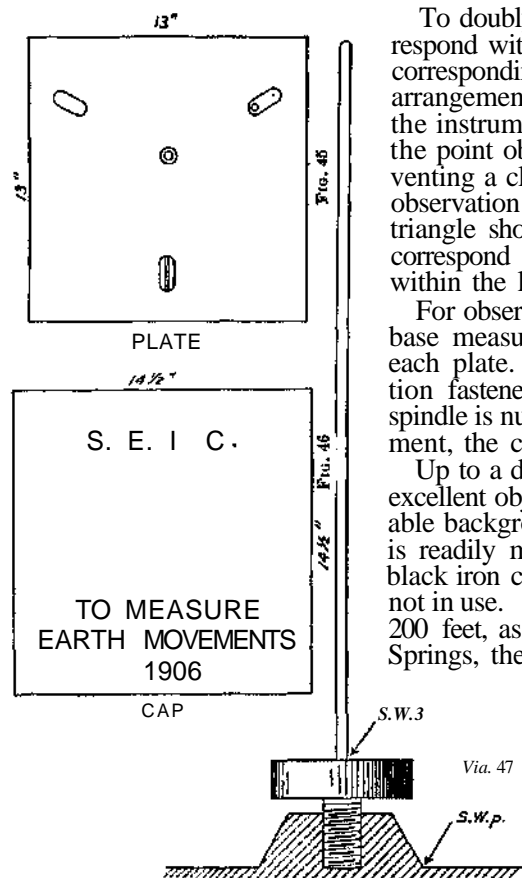

FIG. 46. — Diagram of bronze plate on monuments.

FIG. 46. — Diagram of iron caps protecting plates.

FIG. 47. — Diagram of spindles to be attached to plates.

To doubly insure this, one of the lugs is marked to correspond with a particular support of the theodolite, the corresponding support being similarly marked. This arrangement further insures that even tho the center of the instrument does not correspond exactly with that of the point observed upon (for each monument), thus preventing a closing of the triangles within the accuracy of observation (that is, that the sum of the 3 angles of each triangle should equal  $180^\circ$ ), the angles obtained will still correspond with each other in successive observations within the limit of observational errors.

For observing upon, and also for reference points in the base measurements, a spindle has been constructed for each plate. This spindle screws into a cup-like projection fastened upon the plate for a center-mark. Each spindle is numbered to correspond with a particular monument, the corresponding number being upon the plate.

Up to a distance of about 200 feet these spindles make excellent objects to observe upon, provided there is a suitable background. A background that can not be surpassed is readily made by propping up behind the spindle the black iron cap which covers and protects the plate when not in use. When the distances are greater than about 200 feet, as is the case with the longer lines at Crystal Springs, the best object to observe upon can be made by

whittling the end of a lead pencil to fit into the cup and then wrapping the pencil with a little white cloth. In this case the background should be the same as before. In any event, if tape measurements are contemplated, the spindles should be taken along, in order that they may be used as reference marks in those measurements.

*Leveling record.* — In the following tabulation, *S.W. p* means the top of the bronze plate on the southwest monument, alongside the spindle bowl or cup near the center.

A corresponding point was taken on each monument to show the relative elevations to be retained for future reference.

*S.W. s* is the top surface of the spindle hub, screwed into the socket, made for marking the center on the same plate. These points were taken to show differences of elevation of points used in the tape measures in the base-lines, and are of no value beyond this.

In computing the elevations, the top of the southwest monument was arbitrarily taken as 10 feet, and the other elevations are corrected to correspond with this datum plane.

The spindle bowl is not in the center of the plate, owing to the position of the lugs, so that the point leveled upon representing the level of the plate is on the side of the spindle bowl next to the center of the plate.

The level used was a Troughton and Simms dumpy level with compass attachment.

[Elevations in feet. — Mean results.]

	FIRST MEASURES.	SECOND MEASURES.	MEAN.	BASE-LINE ELEVATIONS.	DIFFERENCES OP ELEVATION.
S.W. p . . .	10.000	10.000	10.000	.....	.....
S.W. s . . .	10.075	10.076	10.076	10.076	.....
Stake A . . .	7.465	7.462	7.464	7.464	- 2.612
N.W. p . . .	8.006	8.004	8.005	.....	.....
N.W. s . . .	8.057	8.053	8.055	8.055	+ 0.591
Stake B . . .	11.694	11.690	11.692	11.692	+ 3.637
S.E. p . . .	11.389	11.390	11.390	.....	.....
S.E. s . . .	11.455	11.456	11.456	11.456	- 0.236
N.E. p . . .	25.877	26.877	25.877	.....	.....
S.W. s . . .	.....	.....	.....	10.076	- 1.380

The relative elevations of the four monuments, taking the center of the plate in each case, are as follows:

	FEET.
Southwest monument . . . . .	(assumed) 10.000
Northwest monument . . . . .	8.005
Northeast monument . . . . .	25.877
Southeast monument . . . . .	11.390

*Base-line measures.* — B. A. Baird in charge, reading rear end of tape and recording. R. S. Badger, forward end of tape and reading thermometer. Charles Evans (laborer), steadying spring balance attached to end of tape and watching tension of 10.5 lbs. The tape used, a 100-foot steel tape, G. M. Eddy and Co., Catalogue No. 703; was stamped on reel "No. 1" for identification in future use. Its width is 0.272 inch; its thickness 0.010 inch; and its weight per foot 3.8324 grams or 0.00845 lb. This tape, on May 1, was compared with the standard tape at the University of California, a long level stretch on the "bleachers" being used for the purpose. The standard tension of 10.5 lbs. was adopted, and no difference in the lengths of the tapes could be detected.

The standard tape, N.B.S. No. 8, is marked only at zero and 100 feet. The comparisons were made between these marks, and the equality of zero to 50 feet and 50 to 100 feet was measured on the tape used in the base-measures, there being no measurable difference.

The constants of the standard tape, N.B.S. No. 8, are: Temperature of observation, 64.6° F.; Tape supported thruout entire length; tension, 10.5 lbs. avoirdupois; resulting values of spaces at 62° F., assuming coefficient of expansion = 0.0000063 per degree F. are zero to 100 feet = 100 feet 0.00 inch.

FORMULA AND CONSTANTS USED IN BASE-LINE COMPUTATIONS.

- $r - j = \frac{h^2}{2P} - \frac{w d^2}{2P}$ , where  
 Correction for Level =  $r - j - (r - j)$ , where  
 $h$  = difference of elevation of ends of tape.  
 $d$  = distance between supports.
- Correction for Temperature =  $-l(T-t)e$ , where  
 $l$  = length of line corrected for.  
 $T$  = standard temperature = 62° F.  
 $t$  = mean temperature of tape.  
 $e$  = coefficient of expansion = 0.0000063 per degree F.
- Correction for Sag =  $-\frac{l}{8P} \cdot \left(\frac{wd}{2}\right)^2$ , where  
 $w$  = weight of tape per foot = 0.00845 lb. per foot.  
 $P$  = standard tension of 10.5 lbs., the same as used in measures.  
 $d$  and  $l$  same as above.

From the above,  $\frac{1}{24} (|J = \wedge - (\wedge f j \wedge p j \wedge 0.00000002700.$

The correction for *pull*, accounting for elasticity of tape, is not necessary, since the standard tension was used in the measures.

*Level correction.* — In taking the measurements, the center of the spindle, firmly screwed into the cup on the bronze plate, as shown in the diagram, fig. 47, was the reference mark on the monuments.

The ordinary correction for level,  $\frac{h^2}{2P}$ , is not sufficiently accurate when the differences are large, and a second correction has been allowed for. In the corrections at Crystal Springs, even third approximations are necessary.

The computed values of the measured lines are summarized as follows:

[Computed lengths of bases (feet).]

	FORWARD.	BACKWARD.	MEAN.
N.W. to S.W. Mem. . . . .	.110.1528	110.5115	110.512
N.W. to S.E. Mon. . . . .	.120.5800	120.5878	120.588
S.E. to S.W. Mon. . . . .	79.7728	79.3725	79.373



## CRYSTAL SPRINGS LAKE.

*Description of stations.* — These monuments are about 7 miles northwest of San Mateo on the eastern shore of Crystal Springs Lake, the reservoir of the Spring Valley Water Company. The location is about a mile southeast of Camp Sawyer, which is on the west side of the lake at a point where the lake is very narrow and is spanned by a bridge, close to the northern end.

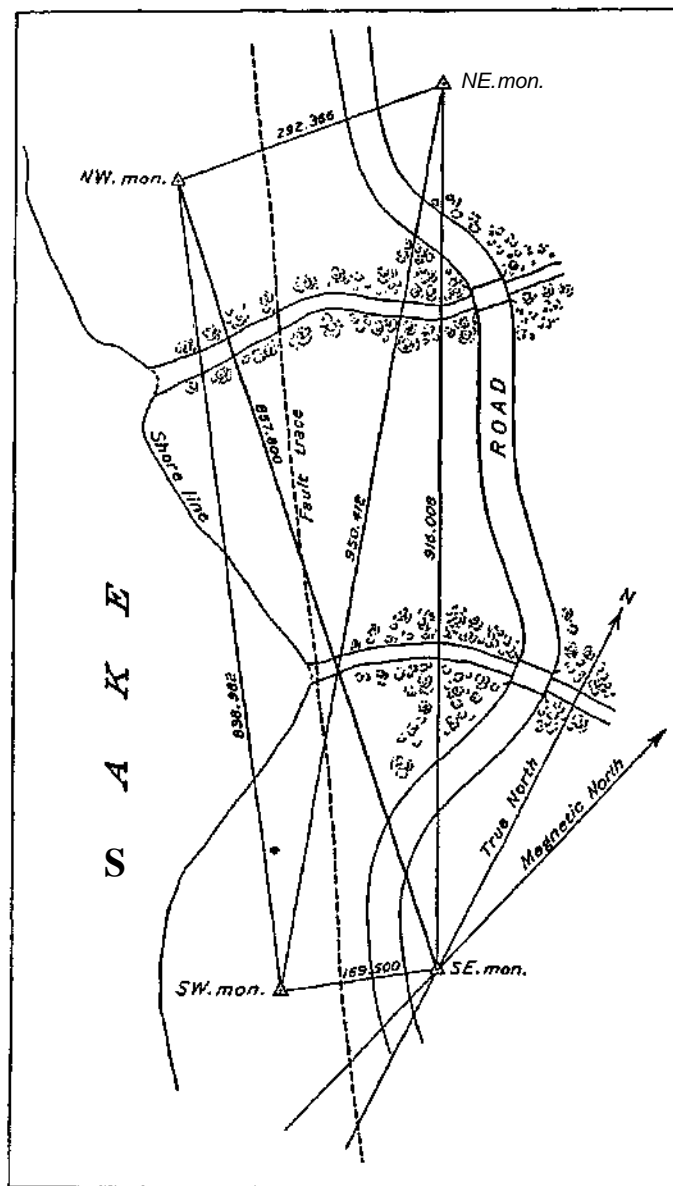

FKJ. 48. — Monuments at Crystal Springs Lake.

As will be seen from the leveling record, and from the accompanying rough sketch, fig. 48, the ground is very uneven, and the measurement of a base-line was executed under considerable difficulty. The line measured, which was the only practicable one, crosses two ravines and comes up toward the southeast monument, over a very steep road embankment. Considerable clearing of brush was necessary in order to cross the ravine near the northwest monument. On account of the large differences of level between the base-line stations in some places, the leveling had to be done with extreme care, there being at one place a rise of 11.5 feet in 80 feet, and, next to the road embankment, a rise of about 6 feet in 20 feet.

The plates, spindles, and caps are the same as those described under "Description of Monuments" at Olema. The distances between these stations being too great to observe upon the spindles with advantage, pencils were wrapt with white cloth and set in the spindle cups upon the plates, the bronze protecting caps being used for background, as in the Olema measurements.

*Base-line measures.* — The stakes, made long enough to stand above the grass, were lined in with the alt-azimuth instrument, and to avoid the possibility of errors they were all numbered on top with a blue crayon. The stakes were made of redwood, and the method of marking was to stick a pin straight down in the top of each at the marking edge of the tape. The tape used was marked to hundredths of feet the entire length, the thousandths being estimated. The measurements were so taken as to avoid estimating the thousandths, excepting on the last measure, the mark being arbitrarily placed at the nearest convenient tenth of a foot on the top of each forward stake.

As the diameter of the pins used was almost exactly the same as the width of the 0.1-foot marks on the tape, the marking could be done with exceptional accuracy, especially by holding the eye directly over the mark in such a way that there would be no parallax. The spring balance was fastened to the forward end of the tape, and steadied by means of a cord looped so as to slip up and down on a pole, held by a man who at the same time watched the tension. To avoid any pulling against the stakes, the height of the tape was regulated by means of the loop so as just to graze the top of the stake. All the marking was done at the forward end of the tape, the officer in charge at the rear end simply steadying on the mark of the previous measure and then reading the tape.

The lengths of the base joining the southeast and northwest monument resulting from the measurements are the following:

	FEET.
First measure. . . . .	857.8020
Second measure. . . . .	857.7988
Mean. . . . .	857.800

*Relative elevations.* — By means of precise leveling the relative elevations of the four fixed monuments, taking the center of the top of the bronze plate in each case, were found to be as follows:

	FEET.
Northwest monument. . . . .	(assumed) 50.000
Northeast monument. . . . .	86.513
Southeast monument. . . . .	75.787
Southwest monument. . . . .	46.113

*Method of observing angles.* — The instrument used was a 10-inch alt-azimuth theodolite, carrying two micrometers 180° apart. Each micrometer head is divided to represent seconds of arc, enabling the observer to estimate to tenths of seconds of arc at each reading. In taking the observations, each micrometer was read to correspond with two consecutive 5-minute divisions, one being back of the reference mark and one in front. The corrections for "run" at each station were based upon the observations themselves, the mean of all observations at the first two monuments being taken both at Olema and at Crystal Springs. In order to eliminate all possible instrumental errors, the observations were, in general, taken in four sets, having for the initial reading of each set, 0°, 90°, 45°, and 135°, respectively; making for the reversal of the telescope, without changing the setting of the circle, the corresponding readings of 180°, 270°, 225°, and 315°.

Thus, upon each station there were eight pointings of the instrument, representing eight portions of the circle equally divided. Since for each of these pointings there are two micrometers, each giving two readings of the thread, there were in reality 32 micrometer readings for each observed station. The above statements apply fully at Crystal Springs, but at Olema one micrometer was not in condition to use, so that the Olema observations, while constituting the same number of telescope pointings, represent for each observed station but 16 micrometer readings.

At Olema, on account of the very small distances between the monuments, large changes of focus were necessary for the different pointings. This, combined with the large differences of elevation, and lack of perfect centering of the instrument on the plates to correspond with the positions of the spindles, prevented the triangles from closing to a very high degree of accuracy. Still, when these discrepancies are reduced to errors of distance, they become practically inappreciable.

At Crystal Springs, where the lines are much longer, the closing of the triangles was very good. The correction for each angle, in order to make the sum of the angles of each triangle equal to  $180^\circ$ , was on the average only about one second of arc. This goes to indicate that this instrument, when properly used, is capable of excellent results. At Crystal Springs a least square reduction of the observations has been made, but the angles and distances thus computed are almost identical with those of the original computation.

At Olema, where the three lines having the least differences of level were measured, the diagonal between the northwest monument and the southeast monument (being best suited for computation) was taken as a base for computing the other two measured sides. The means of the computed and measured distances of these two sides, together with the direct measure of the above-mentioned diagonal, were taken as the best measures for computing the unmeasured sides. The lengths of the three unmeasured sides, therefore, depend not only upon the observed angles, but upon the lengths of the three bases, as indicated above. This method gives the measured distances and observed angles about equal weight, the angles being corrected for each triangle according to what is known as the "field adjustment." As above noted, however, it is very doubtful if the angles are entitled to as much weight as the measured distances, and hence, it was decided to retain the exact values of the three measured distances, and make a "least square" adjustment of the angles of the quadrilateral to correspond.

The three measured sides being assumed as fixed, the three angles of the triangle N.W. Mon., S.E. Mon., S.W. Mon., can each have but one value, and these values have been computed from the three sides. These three sides and the corresponding angles remaining fixed, an adjustment is made between the remaining angles and the three unmeasured sides, so as to fulfill all the geometrical conditions, giving at the same time the most probable values, according to the theory of "least squares."

*Abstracts of horizontal angles.* — In the abstracts of horizontal angles tabulated below, the first set of angles given under the heading "Observed" are the means of angles taken directly from the original records. The column headed "Field Adjustment" shows the angles as they appear in the field computations after the angles of each triangle have been corrected to sum up  $180^\circ$ , giving the same correction to each angle in a particular triangle. This adjustment, which is the usual one made in the original computations, does not account for the other geometrical conditions required for the rigid solution of a quadrilateral, but when the errors in the angles are small, the resultant distances, especially if short, will be very near the truth. The column headed "Least Square Adjustment" shows the angles computed so as to fulfill all the geometrical conditions, giving their most probable values according to the theory of "least squares."

In future measurements, it will not be necessary to repeat the base-measurements unless the angles show some change, for by occupying all the stations, any change that could be detected by tape measurement will at once show in the angles. When, however, the angles indicate any change, then a remeasurement of at least one line will be necessary.

MEASUREMENT OF FUTURE MOVEMENTS ON SAN ANDREAS FAULT. 159

[Abstract of Horizontal Angles. — Oleraa. Mean of eight pointings on each station.]

	OBSERVED.	FIELD ADJUSTMENT.	LEAST SQUARE ADJUSTMENT.
At N.E. Monument:			
S.E. Mon. to S. W. Mon. . . .	37° 33' 23.6"	24.6"	37° 33' 26.7"
S.W. Mon. to N.W. Mon. . . .	57 24 50.4	61.8	57 25 21.6
S.E. Mon. to N.W. Mon. . . .	94 58 14.0	22.1	94 58 48.3
At S.E. Monument:			
S.W. Mon. to N.W. Mon. . . .	63 12 13.4	17.6	63 12 29.7
N.W. Mon. to N.E. Mon. . . .	27 57 59.1	67.2	27 57 48.6
S.W. Mon. to N.E. Mon. . . .	91 10 12.5	13.5	91 10 18.3
At S.W. Monument:			
N.W. Mon. to N.E. Mon. . . .	25 38 40.6	52.0	25 38 41.9
N.E. Mon. to S.E. Mon. . . .	51 16 20.9	21.9	51 16 15.0
N.W. Mon. to S.E. Mon. . . .	76 55 01.5	05.8	67 54 56.9
At N.W. Monument:			
N.E. Mon. to S.E. Mon. . . .	57 03 22.6	30.7	57 03 23.1
S.E. Mon. to S.W. Mon. . . .	39 52 32.3	36.6	39 52 33.4
N.E. Mon. to S.W. Mon. . . .	96 55 54.9	66.2	96 55 56.5

[Distances in feet.]

	MEASURED.	COMPUTED.	MEAN.	LEAST SQUARE ADJUSTMENT.
S.E. Mon. to N.W. Mon. . . .	120.588	.....	120.588	120.588
S.E. Mon. to S.W. Mon. . . .	79.373	79.373	79.373	79.373
S.W. Mon. to N.W. Mon. . . .	110.512	110.508	110.510	110.512
N.E. Mon. to N.W. Mon. . . .	.....	56.768	56.768	56.759
N.E. Mon. to S.W. Mon. . . .	.....	130.191	130.191	130.187
N.E. Mon. to S.E. Mon. . . .	.....	101.584	101.584	101.582

[Abstract of Horizontal Angles, Crystal Springs Lake. Mean of eight pointings on each station.]

	OBSERVED.	FIELD ADJUSTMENT.	LEAST SQUARE ADJUSTMENT.
At N.W. Monument:			
N.E. Mon. to S.E. Mon. . . .	92 01' 49.2"	49.5"	92° 01' 49.9"
S.E. Mon. to S.W. Mon. . . .	11 23 43.5	43.5	11 23 44.9
N.E. Mon. to S.W. Mon. . . .	103 25 32.7	34.8	103 25 34.8
At N.E. Monument:			
S.E. Mon. to S.W. Mon. . . .	10 12 21.8	20.1	10 12 19.0
S.W. Mon. to N.W. Mon. . . .	59 09 45.1	47.2	59 09 47.9
S.E. Mon. to N.W. Mon. . . .	69 22 06.9	07.3	69 22 06.9
At S.E. Monument:			
S.W. Mon. to N.W. Mon. . . .	77 57 38.1	38.1	77 57 37.0
N.W. Mon. to N.E. Mon. . . .	18 36 02.8	03.2	18 36 03.2
S.W. Mon. to N.E. Mon. . . .	96 33 40.9	39.2	96 33 40.2
At S.W. Monument:			
N.W. Mon. to N.E. Mon. . . .	17 24 35.9	38.0	17 24 37.3
N.E. Mon. to S.E. Mon. . . .	73 14 02.4	00.7	73 14 00.8
N.W. Mon. to S.E. Mon. . . .	90 38 38.3	38.4	90 38 38.1

[Distances in feet.]

	MEASURED.	FIELD COMPUTATION (BASE-LINE).	LEAST SQUARE ADJUSTMENT.
S.E. Mon. to N.W. Mon. . . .	857.800	.....	857.800
N.E. Mon. to S.W. Mon. . . .	.....	950.4*14	950.412
N.E. Mon. to N.W. Mon. . . .	.....	292.368	292.366
N.E. Mon. to S.E. Mon. . . .	.....	916.008	916.008
S.W. Mon. to S.E. Mon. . . .	.....	169.500	169.500
S.W. Mon. to N.W. Mon. . . .	.....	838.984	838.982

## ISOSEISIALS: DISTRIBUTION OF APPARENT INTENSITY,

### INTRODUCTORY.

In the study of earthquakes the distribution of the intensity of the shock over the region affected is usually an important part of the investigation. The intensity is inferred, as a rule, from the records of instruments established for the purpose, and from the effect upon persons, loose objects, and structures. In the region affected April 18, 1906, however, seismograph instruments were very few, and the distribution of the intensity of the shock has been determined largely by the effects noted. These effects are graded in various convenient scales and the gradation of intensity is indicated upon maps in the form of lines or curves, known as isoseismal curves, which express, as well as the data available will permit, zones or belts of equal intensity more or less concentric to the point or line above the seat of disturbance. The purpose of plotting such isoseismal curves is to locate approximately that portion of the earth's surface immediately above the seat of the disturbance. In a discussion of the ideal case, the latter is supposed to be a point or *centrum*, and the place above it at the surface is called the *epicentrum*. The increase in our knowledge of earthquakes in recent years has, however, made it clear that the seat of disturbance is rarely if ever a point, but is usually distributed over a plane of rupture in the earth's crust. When, this plane of rupture is of small extent, as frequently happens, the terminology is little affected by the use of the expressions *centrum* and *epicentrum* in the discussion of the phenomena; but where, as in the larger earthquakes, the plane upon which movement in the earth's crust takes place has a great horizontal extent, then these terms become misnomers and tend to obscure the facts. In the present case the inappropriateness of the terms *centrum* and *epicentrum* is glaringly apparent and they will, therefore, be avoided in this discussion.

In the case of the California earthquake, the plotting of isoseismal curves for the purpose of discovering the region on the surface above the seat of the disturbance is in a large measure obviated by the fact that the rupture in the earth's crust is revealed at the surface in the form of a fault traceable practically continuously for 190 miles, and probably continuously for 270 miles. This fault is undoubtedly the principal seat of the movement which caused the earthquake. Notwithstanding this fact, the study of the distribution of intensity is a matter of importance. It is highly desirable, where the plane of rupture is open to the surface and its trace is definitely ascertained, to plot the isoseismal curves, since their disposition under these circumstances may illuminate the general method of determining the position of a deep-seated fault which causes an earthquake, but is not apparent at the surface. It may at least contribute to a definition of the limitations of the method.

It is, moreover, desirable that the distribution of the intensity of the shock should be determined as accurately as possible, since we can not safely assume that the main fault, which appears as a rupture of the earth's crust from San Benito County to Humboldt County, is the only one which occurred on the morning of April 18. Indeed there are *a priori* grounds for believing that more than one dislocation of the earth's crust occurred at the time of this great disturbance of the equilibrium of the stresses within it. If, in a region where stresses have accumulated to nearly the snapping point, a rupture is suddenly effected in one place, it seems probable that the jar thus generated might precipitate ruptures in neighboring parts of the region under similarly high stresses. It appears, therefore, to be highly desirable to plot the gradations of intensity for the region affected; not to discover the trace of the main fault, which is well known, but to see if such gradations indicate auxiliary faults in neighboring territory which did not appear as ruptures

at the surface. In attempting this task, certain conditions which militate against the accuracy of the results and others which affect their interpretation should be stated.

In the first place, the scale upon which the gradation of intensity is indicated, that known as the Rossi-Forel scale, is more or less arbitrary. At the outset of the inquiry, the Commission revised and simplified this scale somewhat, with the object of adapting it for general use, and its present form, as amended by the Commission, is as follows:

- I. *Perceptible*, only by delicate instruments.
- II. *Very slight*, shocks noticed by few persons at rest.
- III. *Slight shock*, of which duration and direction were noted by a number of persons.
- IV. *Moderate shock*, reported by persons in motion; shaking of movable objects; cracking of ceilings.
- V. *Smart shock*, generally felt; furniture shaken; some clocks stopt; some sleepers awakened.
- VI. *Severe shock*, general awakening of sleepers; stopping of clocks; some window glass broken.
- VII. *Violent shock*, overturning of loose objects; falling of plaster; striking of church bells; some chimneys fall.
- VIII. Fall of chimneys; cracks in the walls of buildings.
- IX. Partial or total destruction of some buildings.
- X. Great disasters; overturning of rocks; fissures in surface of earth; mountain slides.

It is apparent that the scale leaves room for wide variation in the personal equation. Different reporters interpret the same experiences and the same phenomena differently. It was also found that in the periphery of the region affected, where the earth waves were of slow period, pendent objects and liquids were more sensitive indicators of earth movement than direct perception by individuals, altho the latter is placed first in the scale. Prof. G. D. Louderback, who reported upon the intensity of the shock in the region east of the Sierra Nevada, makes the following pertinent comment upon this point:

In the towns along the east base of the Sierra Nevada and within 25 or 30 miles of the base, the shock was distinctly felt, movable objects were seen to swing and heard to bump or rattle, and a very small number of persons were awakened. Farther east the most notable feature of the reports is that wherever the effects of the earthquake were made evident, the physical signs, such as the swinging of suspended objects, etc., were described almost to the exclusion of direct physiological effects. This is apparently at variance with the principle upon which the Rossi-Forel scale is founded, as the first three grades of intensity are based on feeling, the visible disturbance of objects not beginning till grade IV is reached. Perhaps the most important physical sign reported is the disturbance of smooth water surfaces. In five instances, at three different localities, ditch tenders or irrigators noticed an agitation of quiet water surfaces, and that water lightly splashed against the sides, as if from low waves, or as in a vessel of water when it is slightly tilted. As the morning was clear and entirely without wind, it impressed them as peculiar, and the matter was reported when they went to breakfast. The suggestion of one that something peculiar had happened, and of another that it was an earthquake, was each in its place the incitement of sallies of wit at the expense of the reporter. News of the California earthquake reached these places several hours afterwards and the time was then found to agree as closely as determinable with the phenomena of the morning. In each of the cases, however, it was reported that no shock was felt. It is suggested that with moderately long waves such surfaces might prove very sensitive indicators of intensities down to the lowest degree on the scale.

The movement of liquids in vessels, ponds, lakes, or streams, is not included in the scale, altho numerous reports were made of such movement and estimates as to the intensity of the shock were based thereon. The stoppage of clocks appears to be a very uncertain criterion of intensity. In the 6th, 7th, 8th, and 9th degrees of the scale, wherein damage to buildings is relied upon for an estimate of the intensity, two important factors tend to vitiate the conclusions arrived at as to the comparative intensity. These are (1) the great variability of the character of the structures and (2) the character of the ground upon which they are built. The scale was probably designed originally for regions where brick and masonry structures prevail, while in California wooden structures are by far

the most common. The latter, by reason of their greater elasticity, are usually much better adapted to withstand the wracking movement of an earthquake shock than are brick and masonry walls. The intensity, as inferred from a region of wooden buildings, would, therefore, in general appear to be less than that for a region of brick or masonry structures. Even among the latter, and among the brick chimneys of wooden houses, which were so generally used as indicators of intensity, there is great variation in strength due to the variation chiefly in the character of the mortar used in their construction.

Along river bottoms and on valley floors, particularly where the ground water is abundant, structures were much more susceptible to damage than similar structures founded on the firm rocks of the valley slopes. This apparently high intensity of the shock in the valley lands was in part due to an actual slumping of the ground, which wracked the buildings independently of any elastic vibration communicated to them from the ground.

Finally, in grade X of the scale, fissures in the ground are taken as a criterion of the highest grade of intensity, when in reality such fissures have under different conditions very different values from this point of view. The fissures which extend down into the earth's crust, and are due to its actual rupture on a fault-plane, are of course significant of the highest degree of disturbance usually experienced in earthquakes; but those cracks and fissures which occur in valley bottoms, due to the slumping of soft material toward the stream trench, or those cracks which are associated with landslides, in those cases where the landslide was imminent and was merely precipitated by the earth jar, are superficial phenomena and do not necessarily indicate so high a degree of intensity as that marked X on the scale. It therefore becomes necessary to discriminate such fissures, and this was not always done in the reports sent in to the Commission.

These various imperfections in the scale used for grading the intensities would of course be minimized if the entire field were examined and reported upon by one observer. The personal equation would in that case, for practical purposes, be constant. But when the observations were made over so vast a field by a great number of persons, so diversely qualified for the work, the errors are necessarily numerous.

Added to this are the large gaps in the records, due to the scant population in the more mountainous parts of the region affected. In these thinly populated tracts, there is not only an absence of individual observations at the time of the earthquake, but also a lack of structures which would reveal to subsequent examination the effects of the shock.

It will thus be apparent that any effort to map the distribution of the intensity of the earthquake can only yield rough approximations to the actual facts. Yet such approximations have their value, and the Commission has not been discouraged by the imperfections of the method from applying it to the full extent permissible under the circumstances. The results are given graphically on the isoseismal map which accompanies this report. (Map No. 23.)

In compiling this map, it has been found best to plot the intensities upon the basis of a literal interpretation of the Rossi-Forel scale, as regards damage to structures. It results from this that in the river bottom the curves represent zones of equal destructive effects, but not necessarily zones of equal intensity, interpreted in terms of acceleration of the vibratory movement of the earth. In these tracts we are confronted with the question as to whether the locally high destructive effects were wholly due to the character of the ground, as in part they certainly were, or whether these may not be ascribed in part to local auxiliary faults in the earth's crust which did not appear as ruptures at the surface. This question will receive special consideration in the sequel, when the facts have been more fully set forth.

It is now proposed to describe somewhat in detail the effects of the earthquake which serve as the basis of the isoseismal map, beginning at the north and going southerly.

## SOUTHERN OREGON.

The most northerly point on the coast for which we have a record of the earthquake shock having been felt on the morning of April 18 was at Coquille, Oregon. Here Mr. E. S. Larsen reports that Judge Harlocker was awakened by the shock at about 5 o'clock. Mr. Wilson and his wife were awakened and noticed the cord of an electric lamp swinging east and west. The regulator in Mr. Wilson's jewelry store, facing east, stopt. Others were awakened. Mr. Larsen also reports that the shock was felt at Bandon, and that at Kerby some claim to have felt it.

At Williams some sleepers were awakened. At Glendale the shock was felt by about 10 per cent of the people. Reports have been received from Nehalem, Tellamook, Newport, Salem, Gardiner, Drain, and Eugene to the effect that the shock was not felt. At Port Orford a slight tremor was felt.

Inland from the coast the following observations are reported by Mr. G. A. Waring:

At Grant's Pass the shock was slightly felt. At Medford a few people felt it, and one woman was awakened by a slight swinging of the partly open door. At Ashland the shock was lightly felt and the sulfur springs nearly doubled their flow for 24 hours, and then slowly returned to normal condition. A few people in Klamath Falls claim to have felt the vibration, but no clocks in a jewelry store were stopt. In Langell's Valley few, if any, felt the shock, but water in an east-west trough was noticed moving slowly from end to end. From two different sources it was reported that at Merrill the shock was distinctly felt, and two old buildings in this place are said to have been shaken down. It was reported that the shock was felt in Drew's Valley, but the people at the stage station there did not feel it nor know of any one in the valley who did. At Lakeview a seconds-pendulum clock facing south in a jeweler's store stopt. The clock was about half run down, it being near the middle of the week. The jeweler says it had never stopt before. One other clock, a spring one, was reported to have stopt in this town, and two or three people claimed to have felt the vibration. Mr. Waring could not, however, find any of these people. At Paisley no shock was noticed on April 18, but on Thursday, April 19, about 1<sup>h</sup> 30<sup>m</sup> A.M., a tremor was felt, strong enough to generally awaken people, and during the next hour and a half three more shocks were felt. Considerable excitement was caused, some people going out-of-doors and one rather delicate woman being made sick. But no doubt the fact that news of the San Francisco disaster reached here late the previous afternoon greatly increased the notice paid to these vibrations. Mr. Waring could learn of no clocks being stopt, the only material evidence being the shaking of a lamp from the edge of an unsteady center table. Enquiry failed to elicit any evidence of a shock having been felt at Bly, Bonanza, Summer Lake P.O., or Silver Lake.

Mr. Waring closes his report with the following general statement:

Judging from all I could learn, I think over most of south central Oregon the vibration was hardly perceptible to people awake. At Paisley and at Merrill stronger shocks were felt. The shock at Paisley was peculiar in being early Thursday morning, April 19, a sort of "sympathetic" shock. No information concerning the time of the shock at Merrill was obtained, but I think it was on Wednesday morning at the time of the great quake. The greater intensity of shock at these two places is perhaps due to the underlying formation. Paisley is built on river ground at the edge of the Chewancan Marsh. Merrill lies in or near Langell's Valley, by Lost River, which here sinks and flows thru swampy land in several places.

## KLAMATH MOUNTAINS AND NORTHEASTERN CALIFORNIA.

*Crescent City, Del Norte County* (George Sartwell).—The earthquake was felt as a northerly and southerly temblor lasting about 5 seconds, with a short intermission. Several pendulum regulators stopt. In the easterly portion of the town the water in a mill-pond was noticed to surge back and forth, disturbing the logs. The ground in the vicinity is of a springy nature. On the morning of April 23 another shock was felt, and



reported by some to be more severe than that of April 18. But Mr. Sartwell, having experienced both shocks, is of the opinion that the shock of April 18 was the heavier. The shock of April 23 was westerly and easterly, and a regulator clock in the shop of D. S. Sartwell, watchmaker, that stopt on April 18, was not stopt on April 23. The same action took place in the mill-pond as on the 18th. Many people felt neither shock. Each time there was a cessation for a few moments of the surf beating on the shore.

*Klamath, Humboldt County* (C. H. Johnson). — There were two shocks, the first being the hardest, and the direction of movement from east to west. The first movement seemed to lift up, the second to settle back and shake. No objects were thrown down.

Prof. A. S. Eakle reports that at Trinidad a severe shaking up was experienced, but the shock, according to the residents of the place, did no damage.

Mr. P. L. Young, M.E., who was in Eureka on the morning of April 18, shortly afterward traveled thru a portion of the Klamath Mountains. He reports that the shock was felt at Arcata, Blue Lake, and up Redwood Creek to Hower's. On the Bald Hills, at an altitude of 3,300 feet, the shock was heavy. At Martin's Ferry, on the Klamath River, two trees were shaken down. It was felt at Weitchpec, at the junction of the Trinity and Klamath Rivers, at Orleans, Somes Bar at the junction of the Salmon and the Klamath Rivers, at Bennett's at the forks of the Salmon River, and at Gilta, a mining camp in southwestern Siskiyou County, about 3,300 feet above sea-level. Seven miles from the latter place, at Brooks, in the extreme northwest corner of Trinity County, at an altitude of 4,800 feet, the shock is described as heavy. At Hower's, on the night of April 22, Mr. Young experienced another very perceptible shock.

*Peanut, Trinity County* (Mrs. Ellen Diller). — Mrs. Diller was in bed on the morning of April 18, partially awake, when she was aroused by hearing a heavy table dragged across the floor, altho she is quite hard of hearing. Attached to the ceiling of the room was a piece of wire about 3 feet long, to which a basket for flowers is sometimes attached. She noticed this wire swinging northwest-southeast thru a space of 7 inches, and thought the wind was blowing. The house shook as if a heavy person were walking in the entry. The clock was stopt, the clock facing the east and the pendulum length being 5.5 inches. Mr. John W. Diller at the time of the shock was awake in bed in a mining camp bunk in a board shack about 8 miles east-northeast of Peanut. It seemed to him as if some one were pushing or pulling the side of the shack off. The man in the bunk below him was awakened but other sleepers in the shack were not.

*Montague, Siskiyou County* (G. H. Chambers). — There was one shock, the estimated duration of which was 30 seconds. The apparent direction of movement was east and west. The shock was strong enough to rattle windows, to cause beds to move, and suspended objects to swing. One clock was stopt.

*Gazelle, Siskiyou County* (O. F. Dyer). — Many persons in bed felt a light sensation. One clock in a brick store was stopt. The vibration was southeast and northwest.

*Sissmi, Siskiyou County*. — Press reports state that some windows were broken and that water in the Southern Pacific Railway tank spilt out.

*Dunsmuir, Siskiyou County* (A. J. Pictet). — Doors and windows rattled.

*Etna Mills, Siskiyou County* (May Lemon). — Several clocks stopt and some plastering was cracked.

Slight shocks are also reported from the Black Bear, Cantara, and Hornbrook, Siskiyou County. At Sawyer's Bar a few clocks were stopt. At Upton a water tank 40 feet high turned to the west, tipping some water out, and then went back to the upright position, according to a report by G. R. Dixon. He was awakened by his building swaying north and south. A rocking chair swayed in the same direction, as did hangings on north and south walls. This was followed by more complex movements, giving rise to nausea.

*Denny, Trinity County* (E. E. Ladd). — The foot of the bed was raised, and then the head, indicating that the shock came from south to north. This was followed by a tremble which caused a rocking motion.

*Big Bar, Trinity County* (W. A. Pattison). — Mr. Pattison was in bed in a very strong block-house, which shook and made a crackling noise. His pendulum clock stopt. Nothing was overthrown. There was a tremor, then a stronger shock. The movement seemed to be from northwest to southeast.

*Papoose, Trinity County* (C. Blackmore). — An electric light bulb hanging by a cord about 4 feet long was swung in an arc of about 22 inches.

*Alturas, Modoc County*. Population 500. (C. B. Towle.) — The hanging lamps in a saloon were found at 5<sup>h</sup> 20<sup>m</sup> A. M. to be swinging east and west. A tub leaning against the house on the porch was thrown down. Some men camped near the town felt a tremble of the earth. Others in camp several miles from the town were up and heard the low sound of the earthquake, but did not feel the shock.

*Susanville, Lassen County* (James Branham). — Mr. Branham was in bed with his head to the north and felt himself roll back and forth in the bed, from which he concludes that the motion was east and west. The shock was, however, not severe enough to be generally felt by people asleep.

*McArthur, Shasta County*. — Two shocks were felt, the first the stronger, the motion being east and west. Nothing was overthrown, according to a report by John McArthur.

*Stella, Shasta County* (J. F. Schilling). — A pendulum clock in the Woodward Hotel stopt.

*Redding, Shasta County* (L. ~F. Bassett). — Mr. Bassett was indoors, squatted on his toes in front of a stove lighting the fire when the shock came. He felt no tremulous motion and only one principal disturbance, which lasted several seconds. There was a slight swaying motion of the house for perhaps 10 seconds, and this was strongest at the beginning. The motion tended to throw one toward the north. No objects were overturned, but the windows rattled a little. A rumbling noise preceded and followed the shock, which he ascribed at the time to a passing train; but there was no train due at that time.

(B. Macomber.) — The shock was not intense enough at Redding to move loose objects. In a few cases clocks were stopt. The shock was felt violently and many people were awakened by it. It was preceded at a very slight interval by a roar. Up to the moment that the most violent part of the shock struck the house, I was under the impression that the sound and the vibration were both caused by a train passing. The direction seemed to be from slightly west of north to slightly east of south.

*Cottonwood, Shasta County* (J. B. Heiderick). — A clock stopt.

#### HUMBOLDT COUNTY.

*Arcata, Hwriboldt County*. Population 950. — A. S. Eakle reports that a few chimneys were damaged. Mrs. William Nixon reports that a fissure opened in one of the streets of Arcata, into which her informant, a reliable man, said he could insert his hand; but by night it had closed again. She was also informed that a brick from a chimney was thrown 40 feet toward the south. The main shock appeared to her to be east and west; two rocking chairs in different rooms, both facing east, were observed by the separate occupants to rock violently. A clock on a north wall did not stop, while many on east or west walls did. Of two clocks on the south walls of the same house, one stopt while the other did not. Mrs. Nixon [places the intensity in Arcata at VIII on the Rossi-Ford scale. She reports further that Blue Lake felt the shock to the same degree as Arcata, with falling chimneys, etc., and that shocks were felt up Mad River at Angel's Ranch and on Redwood Creek at the Berry Ranch. A later shock was felt at 1<sup>h</sup> 10<sup>m</sup> A.M., which stopt a clock on a north wall.

*Eureka, Huniboldt County*. Population 73,000. (A. S. Eakle.) — Eureka was damaged to the extent of about \$1,000, according to report. Most of the signs of destruction had been repaired, but a walk thru tin' town convinced me that the intensity of the shock

was not great. There are numerous brick buildings, but no cracks were caused in any of them. The greater number of the chimneys were unaffected. In the Public Library no books were thrown from the shelves. The large statue of Minerva on the dome of the Court-house vibrated back and forth and finally rested at an angle of about  $45^{\circ}$ . Mr. A. H. Bell, of the Weather Bureau, made a note of the direction of the movement, which was southwest to northeast, and this direction was confirmed by other observers.

(A. H. Bell, Observer U. S. Weather Bureau.)—It was the most severe earthquake of which there is any record at Eureka. It lasted 47 seconds and the vibrations were from southwest to northeast. There were no preliminary tremors, the shock being sudden and the vibrations continuous, with maximum intensity toward the end. Buildings shook to an alarming degree and several were slightly twisted. One frame building moved about 12 inches to the west. Many chimneys toppled over and several hundred panes of glass were broken. There was no loss of life and loss to property did not exceed \$8,000. Chimneys fell in all directions, but most of them toward the west. The statue of Minerva on the dome of the Court-house tipped toward the south until it leaned at an angle of  $43^{\circ}$ .

A second shock occurred on April 18 at  $5^{\text{h}} 22^{\text{m}}$  A. M., and another was felt at  $12^{\text{h}} 25^{\text{m}}$  p. M. These shocks were slight and of short duration. Slight shocks of earthquake also occurred in early morning of April 19; at  $3^{\text{h}}$  A. M. on the 20th;  $6^{\text{h}} 07^{\text{m}}$  A. M. on the 23d;  $10^{\text{h}} 30^{\text{m}}$  A. M. on the 27th; and at  $11^{\text{h}} 10^{\text{m}}$  P. M. on the 30th. There was quite a severe shock on April 23, at  $1^{\text{h}} 10^{\text{m}}$  A. M., lasting about 14 seconds. The vibrations were from southerly to northerly, being of sufficient violence to shake buildings and stop clocks in different parts of the city.

(H. H. Buhne.)—People who were not frightened and who were looking out of their windows described the scene as looking as if all the houses were on the ocean. Only one clock stopt in my house and that was the large regulator in the hall, facing southwest. The other clocks had their pendulums swung southwest, so did not stop.

The shock lasted 47 seconds. It started from a southwest direction. The reason I am so sure of it is that I was passing by my mantel, and one of the statues hit me in the back when the quake started, and it could not have come from any other direction to have done this. It kept swaying the house back and forth for a while, and then wound up with a twister. My chimneys stood it until the twister came, and that made them crack. On examination I found them turned from 0.5 to 3.5 inches. They were all twisted from southwest to north. At my hunting house the shock threw a glass globe and chimney from a large Rochester stand lamp into one of the beds, in a direction about 4 feet from southwest. If it had come from any other direction it would have smashed the glass to pieces.

The damage in Eureka, outside of the Water Works, will not go over \$10,000. Plate-glass windows were smashed in every place except the Buhne brick block. All the plate glass in this building rests on from 0.325 inch to 0.5 inch rubber. The shock picked up one building that stood on made ground and lifted it bodily 12 inches on to the next lot. This building was thrown toward the southwest. The statue of Minerva, 13 feet high and 187 feet from the ground, on the dome of the court-house, was thrown forward to an angle of  $45^{\circ}$ . She was bowing directly south. Chimneys went down everywhere, some thru the roof; others were twisted halfway round. No lives were lost and only one person was hurt by a chimney crashing thru the roof.

*South of Eureka* (H. H. Buhne).—A few days after the quake everything looked all right along the road, excepting chimneys, until I reached Field's Landing, at South Bay. Here the shock opened a fissure over 100 feet long in the middle of the road, which 6 teams spent one day in filling. Pelican Island, as it is commonly called, opposite Field's Landing, dropt 3 feet at the point where the United States pile beacon stands. It left the beacon landing at an angle of  $45^{\circ}$  from the southwest.

At Dungan's Ferry, on the north bank of the Eel River, the ground was full of fissures. Every bar on the river had been opened by fissures, and the gravel toppled over leaving big ditches, some 6 feet deep and over 500 feet long. Coming up on the mainland the road had dropt about 2 feet in one place and was full of small fissures. A 40-acre field was entirely ruined. It was heavily fissured, having dropt down in strips from 2 to 6 feet wide, from 4 to 6 feet deep, and from 5 to 500 feet long, the fissures pointing between south and southwest. All the fields were full of quicksand volcanoes, some 1 to 3 cubic yards in size. They were perfect miniature volcanoes, every one having a crater. It is said they extended 30 miles up the river.

In Ferndale not a chimney was standing and every brick building was torn to pieces. The shock threw two wooden houses sideways. All the plate-glass windows were smashed.

Near the False Cape it threw the old hill, on which the Oil Creek coast road ran, out into the ocean for 0.5 mile. It is estimated that 200 acres were thrown into the ocean. Quite a number of cattle went with the hill. The slide is said to have obscured the view of Cape Mendocino light from Trinidad heads.

In Petrolia the shock threw every house off its foundation; in the mountains it opened great fissures, ruining many acres of good grazing land. It is said that the McKee ranch, near Shelter Cove, is entirely ruined by fissures. About 6 miles below the mouth of the Mattole River, at what is called Sea Lion Gulch, the mountains pitched together, entirely obliterating this dangerous place.

The amount of damage thru the county will not exceed ,1100,000. In the forests thousands of cords of redwood limbs are strewn over the ground and many of the trees were twisted off and hurled to the earth. A friend of mine living within 200 yards of a large body of redwood at Pepperwood, near Eel River, was in the field when the shock came. It lookt to him as if the tops of the trees were almost touching the ground when they were swaying back and forth. It made him quite dizzy to watch the trees. Limbs came crashing down everywhere, intermingled with an occasional terrible crash telling of the fall of one of the giants of the woods.

*Freshwater, Humboldt County.* To the east of Eureka. Population 150. — The shock is described by Mr. S. E. Shinn as heavier than the one he experienced in San Francisco in 1868. Not a chimney was left whole in the town or valley, and glassware in houses was generally broken. The first part of the quake was from east or a little south of east to a little north of west; then came the big wave, like waves of the ocean. The orchard was lifted between 2 and 3 feet as if by a big breaker coming in. At the same time he thought the house would come down; then it seemed to give a lurch and throw the chimney straight north, some of the bricks going 15 feet from the porch. He could not keep his feet except by hanging on the door knob, after being thrown back and forth.

Alexander Coeur states that most of the chimneys in Freshwater were thrown northeast. About half of the chimneys were thrown and the rest were all more or less shattered. Some were twisted from east to west and one was turned halfway around but did not fall. The town is at the foot of a hill near a small stream, and is built on gravel having a depth of about 0 feet.

*Ferndale, Humboldt County,* Population 850. — This town, on the south side of the flood plain of the Eel River, appears to have been the most severely shaken place in Humboldt County. It is the largest town in the county south of Eureka, and is about 2.5 miles from the Eel River, as it now flows thru its flood-plain, 0.5 mile from Salt River, a tributary of the Eel, and 9 miles from the ocean where the Eel River empties therein. The valley to the north of Ferndale, and extending east and west from it, is underlain by alluvium of probably considerable depth. It is very low and subject to floods almost every winter. South of the town are rather abrupt slopes rising to the summit of the ridge which ends in Cape Mendocino. These slopes are underlain by soft sandstones of

Pliocene (Merced) age, dipping uniformly northerly toward the valley of the Eel River.<sup>1</sup>

Mr. A. W. Blackburn, of Ferndale, writing May 2, 1906, contributes the following statement regarding the effect of the shock in that town:

There is general agreement here that the principal direction of the earthquake waves was from southwest to northeast. The main street of the city runs about southwest and the tremor swayed the houses and business buildings from southwest to northeast, breaking over two-thirds of the plate glass windows facing the street, while windows on the sides of the buildings did not suffer nearly so much. One 3-story frame building was caused to lean at an angle of at least 5° from the vertical. Most of the chimneys fell, not one in ten standing, and those that did stand were rendered insecure for the most part. They generally fell either toward the southwest or northeast, where the roofs slanted in those directions. Those who claim to have been out-of-doors when the shock came state that the earth rose and fell in great waves like those of the sea.

The only two brick buildings in town, both of which were one story, with a gable in front raised above the flat roof, had these square gables thrown forward into the street. One was a new building just finished this winter, and its walls were completely ruined, being cracked and loosened. Several buildings were lifted from their foundations, but for the most part the frame buildings were simply swayed out of plumb. Accompanying the quake was a rumbling, roaring sound. The tremor was short and jerky at its point of maximum intensity.

Prof. A. S. Eakle, who visited Huraboldt County at a later date, corroborates the statements just quoted. He says:

At Ferndale the greatest amount of destruction in the county took place. According to Mr. Joseph Shaw and others of the town, the shock came from the southwest and the general direction of the fall of chimneys bears out this statement. There are 2 brick stores in the place, both of which had their upper portions thrown off. Some chimneys were thrown eastward a distance of 15 feet. Several of the frame houses were knocked out of plumb, but only one was moved entirely off its foundations, tho a slipping of a few inches was common. The main street runs northeast-southwest, and the stores on both sides had their plate glass windows demolished. (See plate 66A.) There were no cracks nor sinking of the land in the town and the damage was wholly due to the rocking of the houses. As most of the stores had large glass windows in front, the upper stories were weakly supported from lack of bracing, and this was primarily the cause of their bending out of plumb. Very few frame residences were seriously damaged. It was reported that a brick falling from the chimney of one house was thrown into the bedroom of the same house thru the upper half of one of the windows under the eaves. This illustrates the intensity of the rocking motion to which the structures were subjected.

On the flood plain of the Eel River to the north of Ferndale, Professor Eakle reports that the ground was cracked for a distance of 0.25 mile on the west bank of the river. The cracks were in close vicinity to the river, and seemed to be on the line of an old channel. A series of parallel cracks, some having a vertical displacement of 2 feet, the surface being uplifted and deprest, followed the trend of the river and were evidently local in the soft alluvium. At the time of the earthquake water and sand spouted up in several places thru openings which were in some cases 4 inches wide. Mr. Blackburn reports that this water remained on the surface of the fields for some time after the earthquake. In this same connection, Mr. J. A. Shaw reports that "a field on a high bar near the Eel River was literally shaken to pieces, and water filled with quicksand was ejected several feet high. The rents run from north and south in a curve to east and west. Some parts are actually cut into squares. The jump vertically will reach 2.5 feet. There were no such large rents thru the valley generally, as the upper soil rests on a clay foundation which seemed to stand it all right."

<sup>1</sup> For a geological section at this point see The Geomorphogeny of the Coast of Northern California, by Andrew C. Lawson. Bull. Dept. Geol., Univ. Cal., vol. 1, No. 8, p. 256.

Regarding other parts of the valley, Mr. Blackburn reports that all the other towns bordering on Eel River Valley suffered less than Ferndale. Loleta, on the northeastern edge of the valley, partly up Table Bluff, did not suffer severely. Fortuna, northeast of Ferndale, suffered less than Ferndale, tho only 6 miles distant; other towns up the Valley suffered still less. At Grizzly, population 70, 5 miles east of Ferndale, chimneys were thrown to the ground and crockery in the houses smashed, according to Mr. A. C. Matheson.

To the west of Ferndale, on the coast about 0.5 mile south of Oil Creek, a large landslide was caused by the earthquake and is described in the following note by Professor Eakle: "A section of the coast roughly estimated as one-third of a mile in length split on a 75° plane into the ocean, forming a point of land extending 100 yards or more into the sea. The slide destroyed a portion of the coast road which ran along the edge of the cliffs. The coast cliffs consist of Merced sandstone, dipping 45° to the north, and there is evidence that landslides have been quite frequent here in the past."

*Cape Mendocino Light Station* (R. Jensen). — The shock traveled from southeast to northwest. The light-tower and house were heavily shaken. The brick foundations and water cisterns, as well as the concrete in the yard, were broken.

*Petrolia, Humboldt County*. Population 200. (A. S. Eakle.) — Practically every house was thrown off its foundations. A moderate shock, however, could do much damage to the town, owing to its situation and the way the houses were constructed. The houses are built on the soft bottom land of the Mattole River, several of them within a few feet of the river, and their supports are simply blocks of wood, stone, or concrete resting on the surface of the ground. In the shake-up the blocks under the houses were unequally rocked and some became overturned, causing the houses to slip. The movement was in general east and west. Cracking of the land occurred along the edge of the river in close proximity to the hotel, which was quite badly damaged. Two houses on a terrace about 20 feet high, on the right bank of the river, were not injured as much as those below.

A note from Mr. Blackburn regarding this same town says that the only place which is reported to have suffered relatively more than Ferndale is the little town of Petrolia, on the Mattole River; there frame houses were moved from their foundations and even fell completely; the earth cracked very much and made wide fissures; many slides occurred and the shock was heavier. The general direction of the shock was from the southwest. The valley along the Mattole River is very narrow and the mountains are higher than near Ferndale.

From Petrolia to Shelter Cove we have the following note by Professor Eakle as to the destructive effects of the earthquake:

About 10 miles up the river at Upper Mattole, the ranch house of Mr. Roscoe was moved about 2 inches westerly and the chimney destroyed. At the town of Briceland, on the south fork of the Mattole River, the shock was severe but considerably less intense than at Petrolia. The store moved westward one inch and the stock was thrown from the shelves. Damage to the town was slight, and at Garberville, farther east, it was still less. From Briceland to Shelter Cove by stage road there are but two houses and these had their chimneys thrown off, but nothing more serious. No cracking of the land occurred except in the vicinity of the Cove. The buildings at Notley's, within 1 mile of the fault on the west side, suffered no damage. Even a terra-cotta chimney was not overthrown, altho it was knocked awry. Some of the furniture was displaced and some of the goods in the store were scattered about.

On the stage road between Eureka and Sherwood, Professor Eakle reports that the shock was sufficiently severe to throw some chimneys at the various very small settlements along the road, and that the general movement of the vibration in this section was reported to be easterly and westerly. The town of Fortuna suffered most.

*Fortuna, Humboldt County*. Population 1,100. (L. L. Thornberry.) — Many windows in stores were broken and the stocks of merchandise on the shelves were thrown down.

Drug stores suffered most in this respect, and bottles fell principally from the west side. Over half the chimneys in the town were thrown down. Several houses moved from 1 to 3 inches off their foundations. The river water swashed up on the banks. Fortuna is partly on the river bottom and partly on the hill slopes above, the Eel River being to the west of the town.

*Pepperwood, Humboldt County* (J. F. Helms). — In the stores and saloons 10 per cent of the property was destroyed by breakage, but on the farms of the neighborhood the damage was mostly confined to the throw of chimneys.

*Briceland, Humboldt County*. Population 150. (J. W. Bowden.)—The village suffered damage to the extent of \$1,500 due to the breaking of chimneys, water and gas pipes, household furniture, etc. The village is on sloping ground on the creek bottom, the latter being in solid sandstone and shale, with the bedrock near the surface generally. One 2-story building 30 x 80 feet, standing east and west on a concrete foundation, was moved north 3 inches on the west end and south 5 inches on the east end.

On the east bank of the main Eel River, to the east of Laytonville (A. S. Eakle), the ground was cracked for a distance of 300 yards, the trend of the crack following the course of the river. The crack was merely local in the alluvial bank of the stream, perhaps 100 yards from the water. A long bridge crossing the stream at this place showed no effects of the shock and the few houses in the vicinity were not damaged in the least. Further east, at Covelo, the shock was not violent.

*Thorn*. — Dishes were shaken from shelves in houses.

#### NORTHERN MENDOCINO COUNTY

BY E. S. LARSEN.

In the territory from Laytonville to Covelo, and northerly to the boundary of Trinity and Mendocino Counties, the shock was sufficiently severe to awaken nearly all sleepers, to throw milk from pans, and to jar a few things from shelves, but not severe enough to do any damage to buildings. No chimney was reported as damaged. Most of the chimneys are of rough stone, tho a few are of brick. Some plate glass was broken in one of the stores at Covelo, but the building was in course of construction and the windows were temporarily and insecurely put in place. A large proportion of the residents claim to have heard a roar just preceding the earthquake shock, and several report the shock as beginning with a slow east and west motion, and ending with quick severe jerks. A man riding in the hills at the time did not notice the shock, but his horse stumbled repeatedly without apparent cause.

There were a great many earth cracks formed in the Round Valley region. Some were examined, but many had been obscured by the winter rains, while others were not visited on account of the heavy rain which set in and made it impossible to cross the streams or get about in the hills. About 20 miles north of Covelo, about section 2, township 24 N. range 14 W., on the Horse Ranch, and about 700 feet above the north fork of the Eel River, is a crack about 40 feet across and 600 feet long. At the southeast end a ridge of massive sandstone makes that part of the terrace somewhat wider. At either end are small gullies. At the back, to the northeast, a rather steep hill of sandstone rises abruptly from the terrace. Below, to the southwest, the terrace ends in a steep slope which shows evidence of repeated sliding and has several springs near its base. There are no trees on this slope, but the hill back of the terrace is covered with trees and there are some trees on the terrace, mostly on the hill side of the crack, altho several oaks 8 inches in diameter are on the side toward the river. The main crack is about 400 feet long. It is indistinct and disconnected at the northwest end, but gradually becomes more prominent till it reaches a point just beyond the center where the river, or southwest side, is 6 inches higher than the hillside, and there is an open gap of about 8 inches. It then

begins to die out and upon reaching the sandstone ridge turns about the edge of the ridge and continues about 100 feet more in the shape of irregular cracks along the ridge.

The rocks about this crack are probably all Franciscan. The sandstone extends for some distance in all directions and is usually shown only by fragments. Cherts, serpentines, and schists occur a short distance above and seem to be closely associated with the sandstones. The strike seems to be northwest and the dip quite steep to the northeast. No evidence of faulting was found, but the few outcrops showed little structure. The hills for a considerable distance on all sides of this crack are covered with old slides. Careful examination and enquiry revealed no extension of the crack in either direction.

The extension should pass fairly close to the road from Covelo, but none of the ranchers along the road knew of any cracks in the hills until Dobbins' place was reached, 10 miles southwest, on section 14, township 23 N., range 13 W. Here a crack 600 feet long, trending N. 25° W., occurs on a bench 150 feet wide, made up of soft alluvium gravel, etc., bounded on the northeast by a steep hill of serpentine; on the southwest by a steep slope to the creek 200 feet below, and on the northwest and southeast by bedrock ridges. The crack occurs near the outer edge of the bench and the creek (southwest) side is a few inches higher than the hill side. It does not continue into the hard rocks at either end. Between the creek and the hill the ground is soft, miry, and full of springs, while at the edge of the hill irregular cracks are sometimes seen, showing that the muddy flat had likewise settled relative to the hill and indicating that the soft central area had settled relative to the hard, dry slope toward the creek and the bedrock of the hill. The crack runs under the cabin where there was the greatest movement, but tho the cabin is on four pegs, it was not disturbed.

In the absence of a map it may be stated that this crack lines up very well with the one mentioned above and that the upthrow (?) is on the southeast in both cases. Both are in soft material and both are parallel to the streams. Moreover, the road and a majority of the ranch houses are roughly in this line, and cracks off this line would be more likely to escape detection. No cracks were found between Dobbins and Covelo. Several cracks were reported crossing the road from Covelo to Laytonville near the top of the hill to the north of Middle Eel River. They are said to continue at irregular intervals for a mile or more to the north or slightly north of west. They generally trend north to northwest, but vary considerably.

One mile farther west toward the Eel River, a crack cross the rdad toward the north. There is a strip of soft sandstones and shales thru here resembling that found at the Horse Ranch and striking to the northwest. In this strip numerous cracks were found, often trending northwest but varying considerably. Four of these cracks were visible, but others could not be found as the rains had healed them. It was said that the downhill or southwest side was sometimes higher than the northeast side. Only one of these cracks could be ascribed to a slide. The other three might very well have been due to the shock. Just north of W. Geforth's house is a crack 1,000 feet long, trending N. 55° E., and following roughly a low ridge running out from the main hills. It cuts almost at right angles to the main hills and is in soft material which has little slope. It could hardly be an ordinary slide.

On the top of the ridge, where the soft streak crosses the hills at an elevation of about 1,000 feet above the river, is a crack about 50 feet long just below a low sandstone knob, trending northwest partly across the draw at a considerable angle with the crest of the hills. It is irregular and shows no displacement of any kind. It could hardly be a slide.

Still farther north, just beyond E. Gevire's house and about 5 miles from Robbins, is another crack trending northeast. It is probably a slide. Mr. Gevire stated that there were several slides in the hills on all sides of his house, but no other cracks were reported to the north. To the south the cracks extended to the river, but none were known south of the river.



About a mile farther west, at Poon Kenney, several more short cracks were reported trending northerly but varying in direction, and not connecting along their trend, but I could not find any of these. About 6 miles north of the bridge on the Eel River, at a sheep camp called Hole-in-the-Ground, there are said to be a great many cracks running in various directions, but I did not visit them. On the whole, I believe that these cracks were all due to the earthquake, but that they are nothing more than surface cracks due to the jar. They occur only in the soft strips of weathered sandstone and where they seem to be related in trend they also seem to follow the strike of the rocks.

#### SHELTER COVE TO ALDER CREEK.

The intensity of the earthquake shock near the coast of Mendocino County, between Shelter Cove and the mouth of Alder Creek, is of peculiar interest, since along this portion of the coast the fault line is offshore at an unknown distance and has an unknown course, except in so far as can be indirectly inferred. One of the most important factors in the problem of determining the probable distance offshore at which the fault line traverses the floor of the Pacific is the intensity of the shock as experienced at points along the coast. Fortunately we have satisfactory information on this point.

*Monroe, Mendocino County* (D. Besecker). — About 90 per cent of all brick chimneys were thrown down. In houses with shelves and cupboards arranged east and west, 50 per cent of all dishes and glassware was broken. Stores with shelving running the same way had all goods thrown off the shelves. Many buildings of light frame construction were moved from their foundations. This place is in the heart of the great redwood forests, where trees attain a height of 300 feet or more. These tall trees suffered more from broken tops than anything else; few if any sound trees were entirely uprooted. The trees swayed to and fro for fully 10 minutes after the shock. The direction of the motion was north and south. Fissures opened in the mountain sides, and during the present winter (March, 1907) many large landslides have resulted from these openings.

*Hardy* (Alice Kingsbury). — My chimney was thrown down. Many dishes in surrounding houses were broken. My piano was moved 8 inches from the wall. The earth was cracked, both upon the mountains and near the creek, where the earth was broken away from the banks. The logging railway in the woods was somewhat damaged. The walls around the boilers in the lumber mill were cracked.

*WeMport* (M. M. Bates). — All but one of the chimneys in town were shaken down. Large tanks that were on the ground were destroyed, but those built on framework were not damaged. Large cracks were made in the ground, and after the heavy rains of this winter (March, 1907), large landslides occurred. Goods were thrown off shelves in the store. (The town is quite near the ocean on a wave-cut terrace underlain by rock.)

*Inglenook, Mendocino County* (E. Pitts). — Not a chimney was left standing, nor were dishes enough left to eat breakfast on. The town is between the ocean and a belt of timber. Much of the timber fell, owing to the violence of the shock. On the banks of a small lake in the sandhills h'tween the town and the ocean, some alders and willows fell owing to a plumping; of the banks.

*Vletme, Mmdirino County*. — Most of the chimneys in the place are terra-cotta. All the brick ones fell. About \$1000 worth of breakable goods in a general merchandise store was totally destroyed, and about \$300 to \$400 damage was done to the wharf and railroad tracks. All sway-braces on the wharf had to be replaced, and the railroad track was buckled in many places. The bridge across the lagoon sank 3 feet in some places, and was thrown out of line laterally, all the piling supporting the bridge being tilted to the right.

*Trinity, Mendocino County* (J. M. Branscorab). — Of about 15 chimneys in the town, 2 were shaken down.



A. Wreoked Btores, Femdale, Enmloldt County.



B. Wreoked buildingSi Fort Bragg. Looking northwest!



A. Odd Fellows' Hall, a 3-story brick buildings Fort Bragg, Looking east

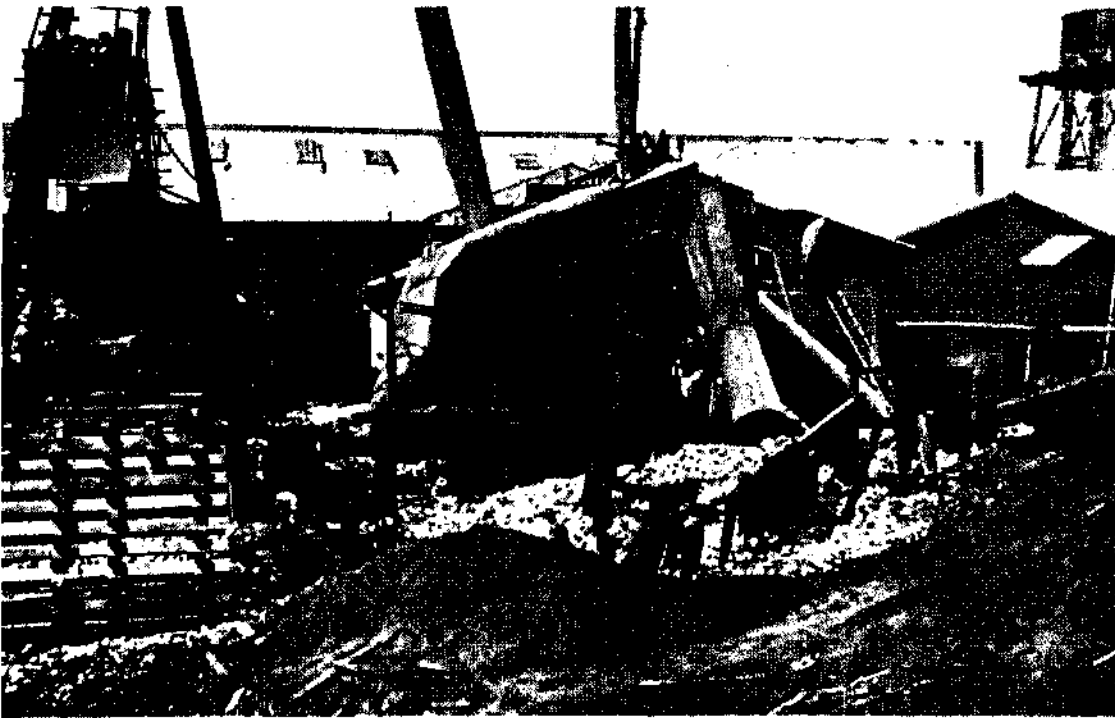

B. U. O. O.'s mill, Fort Bragg, Smoke stack 5 feet in diameter. Entire structure tilted out of plumb to south, 1 foot in 20 feet.

*Fort Bragg, Mendocino County.* Population 1,600. (F. E. Matthes.)—The town of Fort Bragg suffered quite severely, and the indications are that the intensity of the shock was considerably greater than in the towns immediately to the south. Several brick buildings were completely demolished; others had parts of their walls broken off. Even a number of wooden buildings collapsed or were partly wrecked. Fire broke out and devastated 1-| blocks before it could be controlled. The water mains were disconnected and the entire town might have been wiped out but for the timely assistance of the steamer *Higgins* in the harbor. The mill lost its iron smoke-stack, and was temporarily crippled. In all, the damage thru fire and earthquake is estimated at \$100,000. (See plates 66B and 67A, B.)

The following more detailed account of the effects of the shock at Fort Bragg is supplied by Mr. O. F. Barth, principal of the Fort Bragg Union High School:

The first shock had an oscillatory motion. A temblor was felt about 2 hours later, and from 1 to 3 temblors have been felt at irregular intervals nearly every day since.

The direction of the wave of the heavy shock appears to have been toward north by east. The principal fact that justifies this statement is that the monuments in the cemetery, with but two exceptions, fell from their bases south by west. A second reason is that a cylinder printing press weighing not less than 5 tons moved about 3 inches south and 2 inches west upon a level floor. The part of the building containing the press has been finished only a few months, has a strong wooden beam foundation, and was not moved out of position. About a block away a safe in such a position that it could not move in the direction of its rollers, north to south or the opposite, was thrown off its blocks westward 3 or 4 inches. At the high-school building (temporary quarters, not moved at all), a large case about 2 x 4 x 7 feet, full of apparatus and instruments used in physics, moved (rolled out) toward south by west, but nothing was upset within. This case stood close to a central partition on the north side of a south room on the second floor. Chemicals on open case shelving on the outside (south) wall of said room were nearly all thrown to the floor.

At Noyo, 1.5 miles from the center of Fort Bragg, a store 1-story high, having but a floor space of several rooms, perhaps 50 x 60 feet, on underpinning averaging 3 feet high, moved about 22 inches west and nearly as much south. This store stands within 100 feet of the Noyo River. At Fort Bragg most chimneys were broken off at the roof and most of them fell southward, but in a few cases they scattered around the shaft. Those built up from the ground, as a rule, fared worse. The large smoke stack at the saw-mill fell south by west. The brick foundation of a battery of boilers placed north and south was shaken down; another battery close by, facing east and west, was not affected. A large engine with a well-built brick base did not move, nor did the base, nor did the latter crack.

In my house and in several others, dishes on east shelves fell to the floor, while those on shelves on the other sides were less affected, those on the south hardly at all. The south shelves of two jewelry stores fared differently, all the small alarm and other light clocks falling out. In a drug store, one block north of said jewelry store, the north and east shelves suffered most, the north the more; but this may have been due to the difference in the bottles and packages, and to the additional jar of a falling brick building.

Several 2-story wooden store buildings facing west were thrown to an angle southward, the base remaining on the foundation, and the second floor moving from 0 to 20 or more inches. The upper story in most of these remained plumb. Eight brick buildings were shaken to the ground; two are being taken down. A new brick 1-story bank building is badly cracked, and only one brick building, 1-story, is intact. Of the eight, three were 2-story buildings. Many residences were moved, a few as much as 20 inches. Both 1-story and 2-story square built wooden buildings held their own well, except for their chimneys. The four wooden church buildings facing west, and the one facing south, are intact, save chimneys.

One man walking on the street was thrown down. He is positive the wave traveled southwest, the ground undulations being 2 and 3 feet high. Another lookt out of his door toward town, facing southwest. He says the wave traveled in that direction and a roar accompanied it, appearing to go farther that way each second.

At the cemetery, one four-piece monument dropt its top piece to the north by east, **and** the next two pieces as in other cases. The flat or ordinary grave-stones facing east are ail intact.

In the press-room referred to, a bond fire extinguisher was apparently thrown or whirled from a southeast corner shelf out near the center of the room, and right side up. This would bear out the idea of a twist or double movement contraclockwise, apparently experienced by several people, myself included.

There are a number of fissures in the mud flats in and near the Noyo River and Puddin Creek. The boys say there are cracks in the streams. There are cracks in the less solid rocks along the ocean shore line.

(Eri Higgins.)—My house faces west. The east part was moved 6 inches south, breaking water and sewer connections. The west end of the house did not move. Goods on shelves were thrown from the north side, but not from the south side. All brick buildings in town went down except two, and these were damaged.

The above facts indicate that the destructive effects were as severe at Fort Bragg as at any other point within the zone of high intensities, but it is necessary to know something of the situation of the town. Experience elsewhere in the zone of destructive effects has shown that much damage may be caused to buildings even at considerable distance from the *locus* of disturbance, if they are upon soft alluvial bottoms. An inquiry was accordingly directed to Mr. Barth as to the situation of the town and its underlying formations. In response to this inquiry, Mr. Barth replies as follows:

Fort Bragg is mostly on the first terrace. The bluffs rise about 40 to 50 feet above the sea. Then the terrace has a gentle slope thru the town up to the second terrace (a rise of 60 to 75 feet above cliffs), which begins about where the built-up part ends. There is no distinct line of division, but a more rapid rise for a few hundred feet marks the second terrace. It is about 0.25 mile on an average from the bluffs to where the town really begins, *i.e.* going eastward; and the town has a width of a little more than 0.25 mile, from here to the second terrace, still going eastward. The sea-cliffs are rough, rocky, perpendicular walls, or nearly that, for several miles, with many bold, rocky, tooth-like sea-worn isles skirting them.

About half a mile north of town, Puddin Creek, and about a mile south of town the Noyo River, have cut their way thru rather deep canyons to the sea. While the volume of water in the latter is larger, the narrow valleys of the two do not differ much. Narrow strips of tillable land skirt them. The two almost meet about 3 miles east of the bluffs, where there is a narrow divide and where the third terrace appears to begin. There is a gradual rise from the second to the third terrace.

The surface soil upon which Fort Bragg is built consists of a sandy loam, rather sandy and yet pretty firm. The laying of sewer pipes 4 to 6 feet deep reveals more sand below, of a dark yellow color. At the bluffs or cliffs there is from 10 to 15 feet of soil. At one point where the second terrace begins (here Puddin Creek curves in close to town), solid rock comes close to the surface.

A well about 500 or 600 feet north of the business center reached rock at 30 feet. One of the brick buildings, a 3-story hotel which was so badly injured that it had to be taken down, stood about 100 feet from this well. Another well, 0.25 mile north of the business center, obtained water in sand at a depth of 22 feet without reaching rock.

The town is comparatively level from north to south, except for a small valley — hardly that — a 0.25 mile wide vale, running down thru the mill yards to the sea at the point where the harbor indents the coast.

It is clear from this description that the town of Fort Bragg is on a well-defined wave-cut terrace carved out of the hard sandstones which prevail along this part of the coast, and that the terrace is mantled with Quaternary marine sands varying in thickness from 10 or 15 feet at the brink of the present sea-cliffs to 30 feet in other parts, and tapering to nothing at the rear of the terrace. It therefore seems to be a fair inference that the destruction experienced at Fort Bragg is not due, except to a very limited extent, to those causes which work exceptional damage in the water-saturated alluvial bottoms; but that it is referable to the high intensity of the shock, thereby implying proximity of the town to the fault.

(W. T. Fitch.)—There were several small cracks across the roads a few miles south of Fort Bragg; and back in the hills there were more and larger ones. In the bed of the Ten-Mile River, 10 miles north of Fort Bragg, where level surfaces occurred before,

there were noted after the earthquake funnel-shaped depressions resembling extinct volcanoes in miniature. These were only a few feet in diameter.

At Glenblair, 5 miles east of Fort Bragg, the intensity of the shock appears to have greatly diminished. The place is on a creek bank, between high hills. Mr. A. P. Scott reports that the saw mill was slightly damaged and that the store goods were thrown from north and south walls.

*Caspar, Mendocino County.* Population 300. (F. E. Matthes.)—The shock was apparently not so severe. Most of the wooden houses showed no damage. Even the large brick store of the lumber company appeared little affected. It was probably well built and sustained only a few cracks of little importance. All chimneys were broken without exception. The bridge over Caspar River is a total wreck, but it appears to have been a weak structure to begin with.

*Mendocino, Mendocino County.* Population 900. (F. E. Matthes.)—This town, like Fort Bragg, is on the first of a series of wave-cut terraces which score the coastal slope. The present sea-cliffs at the lower margin of this terrace vary from 30 to 100 feet in height. The terrace is veneered with Quaternary marine sands which are in part so compacted and coherent that they may be designated sandstones. The town shows but little damage. Only one large frame building, the Occidental Hotel, was wrecked thru the giving way of its underpinning. Few chimneys escaped destruction. Plaster fell in quantities in some dwellings, while others suffered but little in this respect. Only one out of a considerable number of water-tanks was wrecked. In the river bottom adjoining the town the destructive effect was notably greater. The lumber mill of the Mendocino Lumber Company was the chief sufferer. It lost its tall smokestack, and in addition had its large fly-wheel in the engine-room broken by the shock. This fly-wheel was oriented almost east and west on a north and south axis. According to the engineer, it was not in motion at the time of the quake. The oscillations of its exceedingly heavy rim caused the fracturing of the spokes in the two upper quadrants. The fragments were still visible in the mill yard.

The bridge over the Big River was also severely damaged, a short span in the long approach on the north side collapsing entirely. The structure had been repaired at the time of the visit.

(O. H. Ritter.)—Vibrations at Mendocino seemed to be oscillatory, moving north and south. I remember the feeling clearly, for my bed extends north and south, and moved in a straight line north. The high-school building was moved on its foundations about 2 inches north, and a 3,000-pound safe in town rolled north 3 to 4 inches. The wing of Occidental Hotel which extends east and west collapsed; while the wing extending north and south remained standing, altho the foundation braces were thrown slightly out of plumb in a north and south direction. It is very clear here that the vibrations were north and south. The day after the shock there were numerous cracks in the ground. Chimneys seem to have fallen north and south, generally south; numerous slides on the cliffs took place, some very large. The road between Point Arena and Mendocino was cut off by numerous slides (report of tourist). The bridge across Big River, extending north and south, collapsed. The fall of the span was due to the shifting north of the piles on the north side of the river, thus allowing one end to drop.

(William Mullen.)—The shock at Mendocino began with a tremulous motion, increasing very quickly and decreasing also quickly. The principal disturbance was strongest toward the end. The motion seemed to be up and down, and also from north to south. Chimneys fell mostly to the north, while tombstones fell to the north, south, and east. It lasted about 40 seconds. Beds were moved from 3 to 5 feet and pianos to the same extent. Pictures hanging on walls showed marks of having swung 8 inches. A rumbling sound like distant thunder preceded the shake, and was loud-s\* d the commencement of

the movement. During the shake animals became greatly excited; horses and cattle ran about. Water in some wells became muddy and frothy.

*Navarro, Mendocino County* (F. E. Matthes).—This town is an abandoned one, and the conspicuousness of its damage may perhaps in large measure be attributed to the neglected state of its buildings. Nearly every house, except for the few still occupied, suffered partial collapse of its underpinning, so that from whatever point the town be viewed, it presents the same remarkable jumble of -leaning, half-ruined houses. Its location on the flat, alluvial bottom next the river probably contributed to the severity of the damage. In fact, of the entire series of villages and towns visited on this section of the coast, this is the only one that stands on alluvial ground; all the others are built on firm rock terraces. The great wooden bridge at Navarro showed no damage whatever.

*Greenwood, Mendocino County* (F. E. Matthes).—Weak underpinning caused the partial collapse of several frame houses. Chimneys had fallen without exception. Plaster fell in the lower stories of the few houses containing plaster. The lumber mill was not damaged. Windows were broken in the hotel. If the fault line be produced northward with the last bearing observed, N. 28° W., it will be found to pass about 2.5 miles to the west of Greenwood; that is, nearly the same distance which separates Point Arena (*i.e.* the town of that name) from the fault. Yet the destructive force seems to have been a little less effective here than at Point Arena.

*Albion and Little River, Mendocino County*.—These two small settlements to the north of Navarro are compared by Mr. Matthes with Greenwood. He states that the damage at Albion was on a par with that at Greenwood. Only a few of the weaker wooden houses were crippled by the partial collapse of their underpinning. The bridge suffered but little damage. At Little River the intensity of the shock seems to have been less than at Albion or Greenwood.

Mr. James Coyle, of Albion, reports that he was on a hillside at an altitude of about 500 feet. He heard a roaring noise similar to a heavy fall of hail coming from the ocean to the west. The earth shook back and forth. He was thrown violently to the ground, as were also several cattle and horses that were grazing near. Large rocks were seemingly squeezed out of the hillside and rolled into the river. The trees were shaken northwest and southeast. He noticed only one maximum of intensity. Many houses and bridges were thrown down, chimneys all fell, and large landslides blocked the roads.

*Bridgeport, Mendocino County*.—An extensive landslide came down into the cultivated fields on the flat, wave-cut terrace east of the road.

#### ALDER CREEK TO FORT ROSS.

*Manchester, Mendocino County*.—Population 75. Nearly all the information that we have regarding the intensity of the earthquake shock for the coastal strip between the mouth of Alder Creek, where the fault enters the shore from the Pacific, and the point near Fort Ross, where it again leaves the shore, is contained in a report by Mr. F. E. Matthes. This is, however, supplemented by notes by Mr. W. W. Fairbanks, of Point Arena, for the phenomena observed in the vicinity of that town and by other observers in the vicinity of Fort Ross. In the following pages the statements regarding this territory will be understood to be extracts from Mr. Matthes' report, unless otherwise stated:

Manchester, a small settlement with a population of less than 100, only three-quarters of a mile west of the fault, was severely shaken, yet none of the frame houses in the village itself was badly damaged. A number of them slipt on their foundations, a notable case being that of W. W. Fairbanks' dwelling, which was twisted off its concrete supports, so that one of its corners was found 4 feet from its original place. The rotation was right handed. East of Manchester several farms were visited which were directly on the line



A. Point Arena. Brick house destroyed j wooden houses little affected. P. E. H.

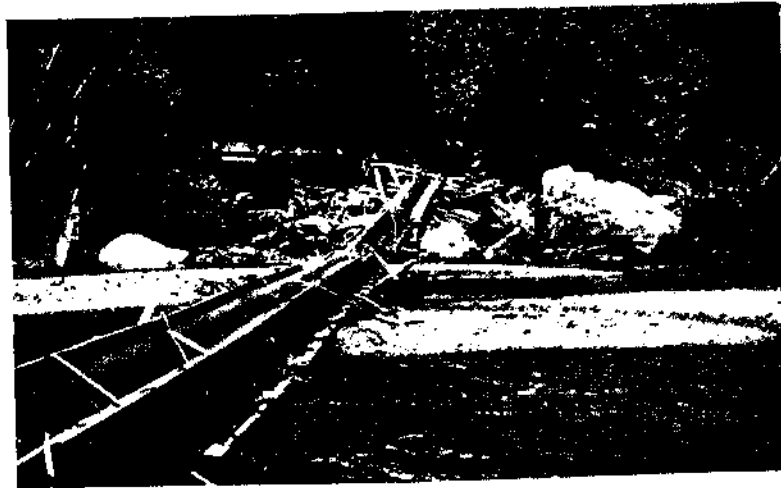

B. Wreck of suspended trestle across Garcia River. Looking west. F. E. M.



C. Collapsed wagon bridge over Gualala River. Boift «d draft 20 feet. F. E. M.





A. Sound redwood tree snapt off 42 feet from top. Near Port Boss. F. E. M.



B. Eedwood tree snapt off. Locality, 0.25 mile east of fault above Fort Eoas. F. B. M.



C. Uprooted tree, 8 feet in diameter, 187 feet long, about half mile west of Garcia Eirer, OH road to Garcia Mill. Taken in 1904. F. E. M.



D. Bridge over South Fork, Qmlala River, 3 miles east of Stewart's Point, looking north. Bridge floor and panels built of 3 inch diameter timbers. P. E. M.

of the fault. A large barn at E. E. Fitch's ranch, thru which the fault past, was practically demolished. The animals in the barn fortunately escaped uninjured.

At Antrim's ranch, on Alder Creek, a tall shed stands on the line. It threatens to fall, but was still up at the time of the visit (May 10, 1906).

The wagon bridge over Alder Creek (plate 32B), which stood astride of the fault, is a complete wreck. The timbers broke in many places, and the tension rods were twisted and in some cases actually ruptured.

Along the Garcia River, the flumes of the L. E. White Lumber Company were reduced to kindling over long distances. Where they cross the river, suspended from steel cables, the end supports of the latter failed and let the flume drop down to the river-bed.

Farther up, between the lumber camp and Hutton's ranch, extensive landslides occurred, chiefly on the east side, wiping out the wagon road which was graded along the mountain slopes. Immediately north of Hutton's ranch, a large landslide plowed into a grain field, producing a series of billowy wrinkles in the soft alluvial material. The outermost ridge has a steep front about 8 feet high and seems to have been thrust horizontally over the level surface of the field. The frontage of the slide is fully 400 feet. Hutton's ranch-houses were all so badly damaged as to become uninhabitable; they are practically wrecked, tho still standing.

Reports from Hot Springs, east of the Garcia, seem to indicate that the buildings there suffered but slight damage. The springs themselves had not been affected by the shock.

From Alder Creek to Irish Gulch, and for a short distance north, rock slides are a common feature and cracks in the ground, frequently traversing the stage road, due to the slipping and settling of large masses on the steep hillsides, are too numerous to be reported in detail. On both sides of Irish Gulch the road was obstructed by slides which had been removed at the time of the visit, but which threatened to recur.

Reviewing his observations as to the intensity between Fort Bragg and Manchester, Mr. Matthes concludes as follows:

The gradual decrease of the intensity as one travels northward from Manchester is to be expected, in view of the gradually increasing distances of the several settlements from the line of the fault (it being supposed that the latter continues with the bearing measured near Alder Creek, N. 28° W.). On this supposition the decrease in intensity should, if anything, become more marked from Mendocino on; but such is evidently not the case. While the intensity does not materially differ at Caspar, it notably increases toward Fort Bragg; so much so, indeed, as to suggest a gradual curving of the fault, roughly parallel with that section of the coast. It is to be noted that over the distance between Fort Ross and Manchester, some 4 miles, the azimuth of the fault-line decreases steadily from N. 46° W. to N. 28° W. This gives a total deflection of 18° in 48 miles. Assuming that the curvature continues northward at a uniform rate, there will be in the latitude of Fort Bragg, 35 miles farther north, a further decrease of the azimuth of nearly 13°. The fault, therefore, may bear only N. 15° W. in that neighborhood. Plotted on a map, the line with such a curvature appears to pass 5 miles west of Fort Bragg.

*Point Arena, Mendocino County.* — Population 300. All the brick buildings in the place had completely collapsed (see plate 68A), and in the opinion of the residents it was deemed wisest to replace them by frame structures. AH brick chimneys had fallen; plaster had cracked and fallen wholesale fashion, especially on the lower floors, and many shop windows and smaller panes were broken. A few wooden buildings suffered from the collapse of their underpinning. As a result of the shock, fire started in the chemical laboratory of the grammar school, and that building, together with the Methodist Church adjoining it, burnt down.

The Point Arena light-house, 3 miles west of the fault, was thrown out of the vertical, and in addition sustained several horizontal cracks thru its masonry. It has been condemned as unsafe and is to be torn down. The keeper's dwelling suffered little damage, one chimney showing cracks, the other appearing intact. The fog signal was not damaged. On the south side of Point Arena harbor, large masses of rock slid down to the beach. Small rock slides took place all along the coast in this neighborhood. A suspended flume over the Garcia River was wrecked (plate 68B) and large trees were overthrown (plate 69c).

This account by Mr. Matthes of the effects of the earthquake in the vicinity of Point Arena is supplemented by the following, account of the destruction effected in the same territory by Mr. W. W. Fairbanks, who was on the ground at the time of the shock. His note covers the section of country from Alder Creek on the north to the town of Point Arena on the south, a distance of 7 miles, and from the coast eastward 1.5 to 2 miles. The note is dated May 5, 1906.

The country described is low and flat, sloping gradually to sea. The coast from the mouth of Garcia River north to Alder Creek is low and flat, with sand-dunes. South of the Garcia, high and rocky bluffs occur, except at Point Arena Harbor, which is at the mouth of a gulch running east to the mountains, the town of Point Arena being on the northern slope and bottom of gulch. Three creek bottoms are embraced in this territory, with higher ground between, somewhat rolling and with outcroppings of rocky ledges underlying.

Nearly every house in the territory described was injured, wracked, or moved more or less. The interior damage was severe. Stoves were thrown down and smashed into fragments. Nearly all chimneys were thrown to the east. Many wind-mill tanks were thrown down, those not containing water generally escaping. All church steeples stand intact, tho in some cases separated from the buildings. All old and flimsy buildings, barns, etc., escaped with least damage, many showing no injury or movement. Strong and stiff frame buildings suffered most. All brick buildings in the territory were thrown flat to the ground, except the government dwelling and light-house at Point Arena. Many frame buildings in Point Arena were utterly demolished. Buildings on or near rocky ledges, or buildings upon high ground with underlying rock formation, suffered the least; buildings on soft ground or creek-bottoms suffered most severely.

The shock came from a southeasterly direction. A heavy roaring sound preceded the shock. The ground moved in undulating swells or waves, rising and falling. Men and animals — horses, cows, etc. — were thrown to the ground, and were unable to rise or stand during the shock.

A great crack or fissure in the earth, starting from the sea-coast at the mouth of Alder Creek and extending in a direct line about southeast by south, termination unknown, past under the large wood and iron bridge over Alder Creek, throwing it into kindling wood. It past under the corner of the barn on Antrim's ranch, wrecking same. It then past thru a potato field, and a large section of same sank about 4 feet. Farther on, it past under a water pond and the pond went dry, tho the water returned in a few days. It past under another barn, a large frame building, and utterly demolished it. All the section of country on the westerly side of the crack moved northwest about 8 feet. Buildings on the east side and near the crack suffered but little; in fact, the section west of the crack received practically all the damage. The crack was about 4 feet wide in places, and the ground was thrown up in a great ridge, as by a gigantic plow.

In Manchester nearly every house was thrown west from 1 to 20 inches. There was one exception, however. A strong new frame house, 2-story, was thrown from its concrete foundations, the rear end swinging to the north and east 5 feet, the northwest corner acting as a pivot and remaining on its foundation pier. The house is built on soft ground near the creek bottom, with quicksand formation underlying. The woodshed and other outbuildings on same lot were thrown and swung in the same direction, but in less degree. Another house, 0.5 mile due east, on the same creek-bottom, swung to east and north, showing the same circular motion, tho moving but a few inches.

Point Arena light-house, erected 1870, a brick tower 110 feet high on a high, rocky point, is still standing but dismantled and condemned. It was broken clear thru in sections, as shown in fig. 49. It leans slightly to the north. The keeper on watch in the tower says: "A heavy blow first struck the tower from the south. The blow came quick and heavy, accompanied by a heavy report. The tower quivered for a few seconds, went far over to the north, came back, and then swung north again, repeating this several times. Immediately after came rapid and violent vibrations, rending the tower apart, the sections grinding and grating upon each other; while the lenses, reflectors, etc., in the lantern were shaken from their settings and fell in a shower upon the iron floor."

Iron rods, supports, railings, and brackets were bent, broken, twisted, and thrown from their positions, making the wreck complete. The dwelling-house, a strong brick structure 50 feet distant, is badly cracked. Chimneys were not thrown, but one on the north was badly broken. The fog signal, 50 feet west of the tower, a wooden building containing heavy

machinery — steam-engines, etc. — was not affected in the least. A high wind-mill and water-tank, 0.25 mile southeast, were unaffected. I am convinced that the shock was comparatively slight here, owing to the solid rock formation underlying. Had it been as severe as at Manchester (3 miles distant), or Point Arena (4 miles distant), both tower and dwelling would have been thrown into ruins.

In Point Arena all brick buildings were thrown to the ground. Main Street runs north and south; all stores and business buildings (wood) on the east side of the street remained comparatively stationary, but all windows facing west in same were smashed, even the sash being thrown into fragments. Interior damage was great. Buildings on the opposite (west) side of the street and facing east suffered no breakage of windows, but nearly all moved west from a few inches to 2 feet. All chimneys were thrown east.

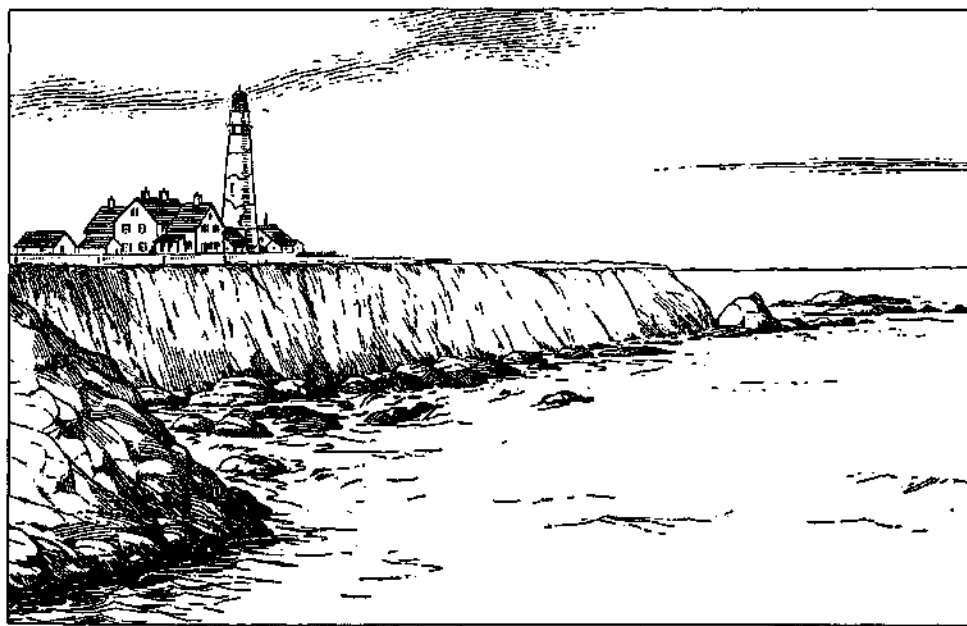

FIG. 49. — Crauks in lighthouse tower, Point Arena.

Buildings lower down on the slope as a rule suffered more, tho several wooden buildings high up, with underlying rock formations, were also wrecked. Nearly all buildings thruout the town moved west or northwest. In many cases houses drifted away and left porches standing in their old location. On the creek-bottoms many small cracks or fissures appear, thru which fine slate-colored sand has been forced to the surface, forming cones.

Between Point Arena and Gualala there are few dwellings and little of a definite nature could be ascertained by Mr. Matthes in his examination of that section.

At Fishrock, population 75, Mr. James F. McNamee estimates the damage at \$1,000. The town is on a terrace of the coast 150 feet above sea-level on rocky ground.

*Gualala, Mmdotino County.* — The wagon bridge over the Gualala River, south of the town, was seriously damaged. It consists of a trussed three-span structure 500 feet long, with a wooden approach of similar length built on trestles 20 feet high thru the swampy bottom-lands on the south side. This approach collapsed completely, the trestles being thrown flat and carrying with them the south end of the main span. The latter, however, did not leave its northern abutments and appears otherwise undamaged. It is considered safe to travel over, altho the bridge floor is now steeply inclined to the south. (See plate 68c.) In the town, population 75, all chimneys broke off; plaster cracked in the hotel and several other buildings; a few small dwellings were thrown off their underpinnings. Household articles and furniture suffered severely, most of the crockery and glassware in the town being destroyed.

A number of landslides blocked the wagon road and railroad track north of the river. A particularly extensive one occurred north of the junction of the branches of the Gualala, burying the tracks under many tons of rock and loose debris.

The railroad tracks of an abandoned logging road west of the Little North Fork show the effects of intensive longitudinal compression. The fault itself was 100 feet east of and parallel to the track along the stream bed, yet the rails have in several places been jammed lengthwise with sufficient force to cause sharp buckling. Stumps and cliffs on both sides of the track prevented the wholesale lateral sliding of the ties and localized the motion to a shifting of the ties a few feet lengthwise here and there. The kinks were so sharp as to cause the rupture of both rails in one place, and of the fish-plates joining the rail-ends in another. The track was narrow gage, with light rails, probably not exceeding 30 lbs. to the yard. In all 6 sharp kinks were counted within a distance of about 300 feet. (See plates 33c, D.)

*Annapolis, Sonoma County* (G. W. Fiscus).—Buildings were destroyed and bridges wrecked in this neighborhood; landslides occurred and the waters of the Gualala River were thrown out 50 and 60 feet on a gravel bar. The river rose 12 or 14 inches in a few hours after the shock. The motion was from southwest to northeast. It started like a wave and then assumed a rotary motion, tearing and grinding. The formations underlying the ranch are said by Mr. Fiscus to be hard-packed sand below the surface soil to a depth of 20 feet, then solid hard rock, as shown in a well 35 feet deep. In this well the earthquake broke out chunks of rock on opposite sides from within 10 feet of the top clear to the bottom. The line connecting the displaced rock on the two sides has a bearing of S. 30° W.

In several places along the line of the fault fissure, the earth has opened so as to allow gravel to fall into the cracks. In other cases water and sand were shot out of the openings, the sand remaining. Chimneys were thrown to the southwest.

*Stewart's Point, Sonoma County*. — The shock was felt very severely here and resulted in the destruction of an unusually large barn, formerly a lumber mill, used for the housing of lumber wagons. The structure was leveled to the ground. Small wooden dwellings were but little affected. All chimneys were damaged and the hotel lost the plaster from the walls of the lower floor. In the upper story the plaster sustained only a few cracks. The village lies about 2.5 miles west of the fault.

East of Stewart's Point the bridge over the South Fork of the Gualala River (plate 69D) was damaged by the slumping of the river terrace on which its south end rests. It was subjected to a strong longitudinal, compressive stress, which resulted in a slight upward buckling of the bridge floor near the southern end, and marked bending and twisting of the tension rods in the 2 southernmost panels. The supports at the south end furthermore appear to have settled 13 inches, causing the floor and the last panel to assume a marked inclination. A hundred yards east of the wagon bridge is an older, dilapidated one, whose floor has been removed for some time. Its rickety aspect and crookedness render it an unsatisfactory object for study in this connection. There is, however, clear evidence of the slumping of the terrace at its south end, in a manner similar to that at the new bridge; yet the old bridge appears to have stood the compressive stress better than the new, and its south end has merely overridden the displaced masses of the terrace.

On both sides of the sharp bend of the river east of the two bridges are extensive landslides, making a clean sweep down the mountain side. The slide on the north side completely blocked the wagon road and was being removed at the time of the visit (May 12). It is of such a height and steepness as to menace the road at this point with renewed sliding in future, especially during wet weather.

*Gualala Valley*. — At Casey's ranch, half a mile west of the fault, the destruction was notably severe, one building having entirely collapsed, and the dwelling-house having

been badly strained by the shock. The ranch stands on the east edge of the ridge, west of the Gualala River, and the fault runs along the mountain side several hundred feet below it. The slope is a steep one, densely timbered except for its upper portion. Landslides were found over a large part of its surface, but only in a few isolated spots had they resulted in the complete removal of the original surface and the forest growing thereon; so that a view from across the river revealed no appreciable changes in the landscape. The slopes east of the river were similarly affected and the fallen timber produced a tangle not unlike that of extensive windfalls. In at least two places the river was temporarily dammed up by slides from both slopes meeting in the stream bed, but none of these dams was of noteworthy size.

On the ridge east of the Gualala Valley, the ranches of A. and Chas. Lancaster were examined and found to have suffered less damage than Casey's. Chimneys were broken, furniture was damaged, and a small slaughter-house collapsed, tho that structure was known to be a weak one to begin with.

Between the two ranches a fissure was found very similar to, tho smaller than, those characteristic of the fault-zone. Its trend was N. 75° E. No marked vertical movement was in evidence, and while the twisted sods and clods along its line clearly indicated a small horizontal movement, this could not be ascertained for lack of definite objects to measure it on.

*Plantation House, Sonoma County.* — Most of the houses in this place stood the shock well. One cottage which was crosed by one of the strongest fault fissures suffered the partial collapse of its underpinning. Had the displacement of the fault not been distributed over a zone 270 feet wide in this locality, the destruction would probably have been much greater. As it was, broken chimneys and windows and slight damage to underpinning were the principal destructive effects within the zone.

*Timber Cove, Sonoma County.* — Altho this town is fully 1.5 miles west of the fault, the intensity was apparently but little less than at places much closer to it. The underpinning of one dwelling collapsed, all brick and tile chimneys broke off, and household articles and furniture were thrown down with violence.

In the bluffs along the coast and in the numerous rock cuts along the wagon road, the rocks appeared loosened up, many old fissures having opened and left the rock masses in more or less unstable positions. Landslides, in rocky as well as in loose material, have occurred in a great number of places, tho none were at all extensive. #

*Fort Ross, Sonoma County.* — At Fort Ross, 0.75 mile from the fault, the intensity of the shock was probably greater than the actual damage would indicate. The old Russian Church and several other buildings suffered thru collapse of their underpinning, but all in a fair state of repair stood the shock, as did the more recently built dwellings.

The dwelling of Mr. G. W. Call, proprietor of the place, was violently shaken. The table was moved across the floor to the south and furniture generally was thrown to the ground. There was much broken crockery and glassware. The contents of a pantry, consisting of jars of preserved fruit, were nearly all thrown from the shelves. In cleaning up the wreck after the shock, 6 wheelbarrow loads of broken objects were picked up off the floors of the rooms. In Mr. Call's room a high case was thrown across the bed in which he was sleeping.

Mr. Call stated that in his neighborhood hanging lamps were caused to swing in a circle corresponding with the apparent movement of the sun. There were several shocks, quickly following each other; the first was not the strongest. They seemed to increase in force up to the third or fourth and to come from different directions. He judged that there was a strong vertical impulse. Chimney tops were thrown off, some chimneys being shattered to the bottom. Many redwood and pine trees were broken off, some at the ground, being uprooted; but generally broken about halfway up. All low fund-

ture was turned over, and a few frame buildings set upon unbraced posts were shaken down. The tendency along the fault seemed to be to crowd the two sides together, as a water-pipe in one place had sprung up in a curve out of the ground. The fact that he found no trees broken at a distance of more than a mile from the fault indicates to Mr. Call that the shock was much stronger near the fault than elsewhere.

Mr. Call resided for some years on the South American coast and had experienced the disastrous effects of sea waves consequent upon earthquakes in that region. The moment, therefore, that he felt the shock he turned his attention to the sea, which is in full view of his house. He reports that it was perfectly still during the shock and afterwards.

South of Fort Ross, at Doda's ranch, a large barn about 150 feet west of the fault was found leaning to one side on the verge of collapse. Several of the dwellings and other smaller houses had slipt from their underpinning. All the chimneys had been broken off or destroyed; household articles and furniture had been thrown down, but no window glass had been shattered or even cracked.

Mr. Doda's daughter stated that she was standing in the kitchen at the time of the shock, and was lifted vertically from the floor more than once, in each case alighting on her feet. A ranch hand who was out-of-doors at the time stated that he saw the water-tank thrown vertically upward about 5 feet and then fall in ruins.

In the forest between Plantation House and Fort Ross innumerable trees, many of them redwoods (*Sequoia sempervirens*) of considerable size, had broken off some distance from the ground (plate 69A, B), or had split lengthwise from the roots up. Some were uprooted altogether, as if by a hurricane. No particular preponderance in direction of throw was noted. Trees on the line of the fault were as a rule split vertically and more or less twisted. In some cases the butts had actually been sheared. A fine instance of this may be seen on the stage road 150 feet east of Plantation House.

At Seaview, a post-office on the summit of the ridge overlooking Fort Ross and probably 1.5 miles from the fault, the shock is described by Mr. Morgan, the occupant of the only house there, as very violent. In a room with two beds, one moved across the room to the south, the other was lifted from the floor. The chimney was thrown to the north.

On the wagon road from Seaview to Cazadero, the steep bank of the road-cuts, generally of disintegrated sandstone, had in numerous places slid down upon the road.

At Cazadero the shock was severe and chimneys were generally thrown, but no buildings were wrecked, all the structures being of wood. Mr. H. L. Conley, of this place, stated that according to his observation the shock was from north to south, chimneys falling south. In a store the chief walls of which trend north and south, hardly any damage was caused. Some pictures hanging against walls were turned around so as to face the walls. There seemed to be two maxima, the second being the strongest.

#### BETWEEN THE COAST AND THE UPPER RUSSIAN RIVER.

For thr territory between the coast and the upper Russian River Valley, we have the following notes by Dr. H. W. Fairbanks:

At Sewerville the shock was much less severe than at Santa Rosa. Chimneys and por-  
 tico of brick walk were thrown down. The shock at Skaggs Springs, 8 miles west of  
 (teywm)le, was not severe. Chimneys were knocked down, but no other damage was  
 done. On the wimmit of the ridge, 6 miles west of Skaggs Springs, chimneys and crockery  
 were broken, the shock apparently being fully as severe as at Skaggs. There are no other  
 TO !!f^m^l^r^l^v^r^.. d until within 2 miles of the Rift, where the shock

Another ^ction is that across the country from Point Arena to Cloverdale. At Boone-  
 ?T^l^v^m^all^the^k^te^a settlement. About half the chimneys were down  
 and Ik. Diddle, apparently the best-informed man in the town, thinks that the shock wa^



A. Bell and Kinslow building, Healdsburg. Per J.O.B.



B. Odd Fellows' Hall, Healdsburg. Per J. O. B.



somewhat more severe than at Ukiah. Booneville is a little more than halfway from Point Arena to Ukiah. Ten miles southeast of Booneville on the Cloverdale road, a point a little nearer the Russian River Valley than Booneville, no damage to speak of was done, one chimney being slightly cracked. Sixteen miles southeast of Booneville, a little more than halfway between that place and Cloverdale, milk was thrown out of pans and houses badly shaken. At a house a half mile away cream upon milk pans was not broken. On the mountain 5 miles west of Cloverdale there was no damage done. Two miles west of Cloverdale about half the chimneys were broken. The town itself does not seem to have suffered more than the average place along the road. Most of the chimneys were merely cracked and not thrown down.

While there seems to have been great variation in the intensity of the shock in the sections traversed, it is not clear that there was any increase in the intensity of the shock in the direction of the Russian River Valley at points between it and the coast.

Supplementary to these notes by Mr. Fairbanks, Mr. John L. Prather, of Philo, reports that at that place chimneys were thrown down and broken off above the roof, and in some cases turned quarter way round, clockwise. Glassware and crockery were generally broken and much damage was done in stores and farmhouses.

#### HEALDSBURG TO WILLETS.

*Healdsburg, Sonoma County.* Population 1,870. (R. S. Holway.) — This place comes next to Santa Rosa in the extent of damage done to towns in Sonoma County. The shock was definitely less severe, however. The new 3-story brick building of the Odd Fellows Society is a total wreck, as are several other buildings, but many brick structures stood the shock without serious damage. The cemetery is on a low hill similar to that at Santa Rosa, and as at the latter place not over half the monuments fell. Of 35 square monuments of the same class, the direction of fall was as follows: north, 10; south, 11; east, 10; west, 3; southwest, 1.

Along the bottom-land of the Russian River, cracks from an inch to a foot in width opened at several places.

(H. R. Bull.)—The direction of the earthquake at Healdsburg seemed to be from north to south during the early stage of the disturbance. Following this was a decided pause attended by a quivering motion; then followed a vertical movement attended by a great rumbling noise like thunder; lastly, the distinct oscillatory movement which continued thruout.

A piano with its back close against the north wall was shifted 2 feet almost directly toward the south. It was evidently lifted and rolled simultaneously, since the base-board of the piano was thrust out upon the floor ahead of the piano. A clock on a south wall was thrown 5 feet to the north, while a clock on a north wall was thrown to the south. Plastering on walls extending north and south was badly broken and scattered, while that of the ceiling and the walls extending east and west was only slightly injured. One chimney was hurled toward the east, another toward the south. North and south walls of a brick dwelling 40 feet north of the frame building above described were thrown toward the south. Furniture in this building was shifted also in a similar manner. Residents generally agree as to the general movement being from north to south.

Fissures in the creek bed near the town are in evidence. Water was thrown out and continued to flow for several hours, at first with some considerable force; then it gradually diminished and finally disappeared. Brick buildings were generally injured and in some instances thrown down. (Plate 70A, B.) Many brick walls facing east and west were buckled either in or out, because of the movement from north to south of the north and south walls. Chimneys generally fell north or south. In some east's the oscillatory motion caused chimneys which had withstood the north and south wave to fall in other directions.

(George Madeira.) In the bed-room a heavy walnut and marble composite bureau, mounted on rollers and weighing 400 pounds, was moved toward the center of the room by the first wave motion, which was north to south. It then turned so that the large mirror surmounting it was due north. In the house are three chimneys built close together. One chimney above the roof fell to the south; but beneath the roof one fell to the south, one to the north, and one to the east, on the ceilings of the back parlor, dining-room, and sitting-room respectively. A large pier glass 8 feet high, with a very heavy marble base, was turned northward. There were two maxima in the shock and the second was the more violent. The first was from north to south and the second from east to west. Not a building escaped damage to some extent, whether made of wood, brick, or stone. There were five brick buildings destroyed. Mr. Madeira estimates the loss at between \$200,000 and \$300,000. Along the creek and river bottoms the earth was fissured and water was forced up which, in some instances, flooded the orchards.

*Alexander Valley to Mt. St. Helena* (R. S. Hoiway). — This trip was made in order to cross the line of the fault described by Mr. V. Osmond<sup>1</sup> on the southwest slope of the mountain. No sign of recent movement was seen, however, and no reports of cracks or landslides were obtained. There are few houses from which to obtain reports. Some chimneys fell as far as Kellogg at the foot of the mountain. At Nays — elevation about 1,500 feet — and at the toll-house southeast of the summit — elevation about 2,300 feet — a severe shock was reported, but nothing was shaken down. In climbing the last 2,000 feet to the summit, large boulders were frequently seen balanced on points and yet not overturned by the shock. The intensity decreased from IX at Healdsburg to about VI on top of the mountain.

Alexander Valley is part of the Russian River Valley lying east of Lytton Springs. The main bridge across the Russian River was wrecked, the trestle-work part going down. The bridge was old and was to have been rebuilt this year. At the east end of the bridge cracks cross the road, northwest to southeast, parallel to the river bank. These cracks appear at intervals northwesterly, at least as far as the ranch of Rev. B. B. Ware, about a mile up the river. The cracks vary from a few inches to over a foot in width, and are sometimes 200 to 300 feet long, roughly parallel to the river. Mr. Ware states that the shock threw the river water upon the sandbars to such an extent that he found fish there during the day. Other cracks are reported a mile or two northward. Subsidence frequently occurs where the cracks are near the bank.

*Cracks in the Russian River Flood-plain* (R. S. Holway). — Cracks have been observed at intervals in the alluvial banks of the Russian River from near its mouth to Alexander Valley, 5 or 6 miles northeast of Healdsburg. These cracks are sometimes 100 yards in length and from a few inches to 2 feet in width. Sometimes near the bank there will be a deep fault 5 to 6 feet in width and 100 feet long, as shown in the photograph of the crack at Monte Rio. The direction of the cracks is usually parallel to the bank of the river or the bank of some small tributary. At Duncan Mills the cracks ran north and south above the bridge and nearly east and west just below the bend of the river. At Monte Rio they are east and west. In Alexander Valley they run north and south, while a mile or two below some are found nearly east and west running up a small tributary.

*Maacama Slide, 6 miles easterly from Healdsburg* (R. S. Holway). — This slide is on the north side of a ridge that runs in an easterly direction and that is at this point from 225 to 300 feet above the bed of Maacama Creek, which runs along the foot of the north slope. Mr. Hugh Simpson, whose house is just beyond the foot of the slide, states that the entire slide took place at the instant of the earthquake. The slide is about 0.125 mile wide at the top and about 0.5 mile long. The rock is a very light, porous, volcanic

---

<sup>1</sup> Bull. Dept. Geol., Univ. Cal., vol. 4, No. 3.

tuff and seems to be free from water. A slicken-sided wall on the east shows a very-smooth surface in spite of the soft rock. Striae near the top run N. 13° W. with a pitch of about 24°. The slide seems to have taken off some of the top of the ridge; that is, it started a few feet down the south slope of the ridge, cut its way thra a fir forest and dammed Maacama Creek with rocks and trees. Either two successive slides occurred or else the upper part of the moving mass was arrested part way down, for a bank with the vegetation of the top rests across the slide about one-third of the way down. (See plate 124A, §.)

This slide was subsequently visited by Mr. G. K. Gilbert, who contributes the following supplementary note:

At Maacama schoolhouse, I saw the large landslide described by Professor Holway. The rocks involved are in layers, with a dip of about 30° in the direction of the slide. It is therefore probable that the slide was partly determined by the dip, tho it seems to have been further determined by the erosion of the valley of Maacama Creek. The shock at that point was notably strong. A young man living close by told me that he was watering two horses at the time, and kept his feet only by holding on to a pump. Both horses were thrown down. The house of Mr. Stimson was thrown from the pegs on which it stood, and all brick chimneys in the neighborhood were broken. He and others mentioned numerous cracks in the bottom lands a mile to the north, and especially in the bottom lands of the Russian River at its neighboring large bend.

*Geyserville, Sonoma County* (R. S. Holway).—Shock reported north and south and northwest and southeast. Several brick buildings were badly cracked and tops of fire walls thrown down. The northwest wall of a butcher shop (brick) was thrown out against an adjoining frame building, which saved the brick building from an entire fall. Half or more of the chimneys were reported down. Goods were commonly thrown from shelving in stores. The cemetery 1.5 miles northwest in the low hills was not disturbed. The bridge across the Russian River at this point was unhurt. The town is on the west side of the river, on alluvial terraces.

*Cloverdale, Sonoma County* (R. S. Holway).—The upper walls of a brick building nearly opposite the United States Hotel were cracked so as to necessitate partial rebuilding. A 2-story brick building on First and West streets was unhurt except for cracked plastering. The shock was reported north and south; goods were thrown north and south from the east and west walls. In a 1-story brick building at Broad and West streets goods were thrown from the wall facing north. In the grocery opposite the United States Hotel goods were thrown mostly from the wall facing south. The inspector reports that he has condemned four-fifths of the chimneys, but most estimates agree that not over one-fourth fell. Mr. Scott reports that he went out-of-doors during the shock and that distinct waves in the ground could be seen moving from the west toward the east. The cemetery is on a knoll on the bank of Russian River, and suffered no damage except the fall of a vase from the top of a tall monument. This fell to the north.

(M. C. Baer.) On or about 9<sup>h</sup> 30<sup>m</sup> P. M., April 11, a slight shock (class III) was felt. The general direction seemed to be east and west and to have a trembling motion. The next shock came at 5<sup>h</sup> 13<sup>m</sup> A. M. on April 18, and was of about class VIII. The motion was at first oscillatory, but seemed to end up in a series of jerks. There did not seem to be any general direction. All chimneys were cracked; many windows were broken, and many brick chimneys and buildings were shaken down. The bricks of a chimney from a building about 30 feet high were thrown southward about 70 feet. Generally the chimneys seemed to have shifted or fallen southward, but in some cases they have tended to go in other directions. Many telephone wires were broken. In most cases water was spilt from water-tanks on all sides. It is reported that the water of several streams was partially thrown upon the banks. No cracks in the earth's surface have been reported.

*Ukiah, Mendocino County.* Population 2,000. (R. S. Holway.)—A brick building owned by Mrs. White was so badly damaged that it is being taken down. The north fire-wall of the McGlashan Building was thrown down and the engine house is reported unsafe. Mr. Cunningham, inspector of chimneys, reports some 30 to 40 actually down, but probably one-fourth of all chimneys condemned. Sexton Rogers reports no damage in the cemetery. The State Asylum for the Insane, a large brick building, is east of the river and some 2 miles away. The gables fell out, coping and ornamental stones fell from walls, and chimneys fell generally west or east. In one case, where a chimney was braced by an east and west rod, the washer was pulled thru into the flue, but the chimney remained standing. At Vichy Springs a greatly increased flow of water is reported. The water was milky for a few days. Increased temperature was reported, but no thermometer was used to determine this.

(Geo. McGowan.)—The town is partly on bottom-land and partly on a bench slightly above the bottom. There is no rock near the surface and none of the ordinary wells go to rock, but pass thru washt gravel and clay. Ukiah Valley is approximately 12 miles long, and 2.5 miles wide, lying about north-northwest and south-southeast, and surrounded by mountains. Russian River enters at the north end of the valley. At this place it is at the extreme east side and continues near the east side to its exit at the south end. The greater part of the valley floor is alluvial fill. It is nearly level except for a depression toward the south to correspond with the grade of the river. Ukiah is a little to the west of the center line of the valley and about 4 miles from the north end. There are several deep canyons at right angles to the valley in the bordering mountains.

In the town a 2-story brick building, rather flimsily built, the front being set on pillars, was canted about 6 inches to the south, breaking most of the plate glass in the front. It struck against a 2-story brick building just completed, also set on pillars, and the latter was set over nearly a foot and the walls badly cracked. The greater part of a long fire-wall on the north side of a 2-story brick building fell and an inner wall that served as the casing of a stairway was badly cracked. A large number of chimneys were dislocated and some were thrown down. Some of our well-built structures suffered. Quite a number of houses had the plastering more or less cracked. The railroad lost a large water-tank which was thrown down and demolished, tho a large oil-tank near by appears to be uninjured. The shock caused an old sheet-iron tank full of water to break loose at numerous points around the bottom and lose its contents in short order. Of two pendulum clocks one was stopt. Chimneys and loose objects were thrown to the north and south, some one way and some the other, and some chimneys that were not thrown were dislocated and turned partly around, in a direction opposite the apparent motion of the sun. The electric-light bulb hanging over my bed swung first back and forth, then changed to an ellipse and finally almost to a circle. There were two principal maxima, of which the first was the stronger. The first movement was north-northwest and south-southeast and this was succeeded by a twisting motion.

Mr. S. D. Townley, in charge of the International Latitude Observatory, 1 mile south of Ukiah, reports:

Many chimneys were thrown down from 2-story buildings, and also from some cottages. One new brick store building just nearing completion was so badly cracked and thrown out of plumb that it is necessary to tear it down, and several other brick buildings were damaged to a greater or less extent. The particulars are given in the *Ukiah Press* for April 27. A rough estimate of the number of chimneys in town would be 1,000. P. B. Westerman, teacher in the Ukiah High School, reports that 120 chimneys fell, most of them either to the north or south. At the Asylum on the eastern side of the valley, chimneys fell to the east or west. Cemetery monuments were not overthrown. One chimney on a house 200 yards southeast of the Observatory was badly cracked.

At the Latitude Station no damage whatever was done, altho the shaking was the most severe ever experienced by the writer. Dishes rattled, milk was spilt from pans little

more than half full, and fowls and other domestic animals were very much perturbed. There was a series of shocks, and reliable estimates of their duration vary from 20 seconds to 1 minute. The general direction seemed to be from southwest toward northeast, but others report a different direction. The Uldah Valley is surrounded by mountains of considerable altitude, and it is probable that some of the shocks felt were reflected from the mountains. Hence it is that the earthquake is generally spoken of as a "twister."

The Observatory clock was not stopt, but it lost 6 seconds during the disturbance, which is equivalent to being stopt for that length of time and then set going again. The Observatory roof is built in two sections, which roll upon horizontal tracks, east and west, giving an opening of about 13 meters for observation. When closed the two parts are fastened together by means of a hook and eye such as are used on screen doors. The hook rests in a horizontal position and the bend of the hook in a meridian plane. The effect of the earthquake was to unfasten this hook and open the roof to the width of about 20 centimeters, my recollection being that the eastern half was moved about twice as far as the western. The pier upon which the zenith telescope rests was apparently not damaged, but the telescope was thrown considerably out of adjustment. It was out about 15 seconds of arc in azimuth and the vertical axis was out in both directions, but not much more than sometimes results from extreme changes in temperature.

The first series of shocks was followed by three lighter shocks and the observed data for each are as follows:

PACIFIC STANDARD TIME.				DURATION ABOUT.	DIRECTION.	INTENSITY.
Apr.	IS <sup>d</sup>	5 <sup>d</sup>	13 <sup>m</sup> — <sup>B</sup> A. M.	40 <sup>s</sup>	SW. to NE.	Severe
	IS	10	4 39 A. M.	10	SW. to NE.	Medium
	18	11	36 0 A. M.	30	SW. to NE.	Light
	20	12	30 53 A. M.	—	—	Very slight

The times are correct within 2 or 3 seconds.

I was in the observatory at the time of the second series of shocks, 10<sup>h</sup> 4<sup>m</sup>, and perceived the effect of the movement in the striding level (east and west) of the zenith telescope. The bubble oscillated over about 2 divisions of the level. The value of one division is 2.2", and as the distance between the east and west leveling screws of the instrument is about 42 cm., the disturbance produced in the bubble was equivalent to the effect of raising and lowering one of the leveling screws by 0.0005 centimeter. This shock was felt very distinctly and it is probable that the north and south component of the motion was much greater than the east and west component. The fourth shock was not felt at all. It was detected during the progress of latitude observations, by a movement of the bubbles of the latitude levels. The oscillation (north and south) was about one-half of one division, and the value of one division is 1 inch.

My estimate of the intensities for the four shocks given above would be, respective<sup>ly</sup>, VII, IV, III, I. The Observatory is about a mile south of the city of Ukiah, and it seems certain that the earthquake was more severe in Ukiah than at the Observatory. The intensity of the first shock at Ukiah would certainly not be less than VIII, possibly IX.

The direction of all shocks was southwest to northeast, according to bodily impression.

*Willets, Mendocino County* (R. S. Holway). —• Brick chimneys were quite generally wrecked. The Buekner Hotel was completely demolished. One wall fell at the time of the shock, killing Mr. Taylor, **the** proprietor. The building finally fell at 10<sup>h</sup> 20<sup>m</sup> A. M. The structure was largely frame, with some brick veneer. The stores of the Irvine Muir Company were badly wrecked. Fire-walls **foiled**; plaster, shelving, and goods were thrown to the floor. Brick walls fell in several other stores, and frame buildings were in some cases thrown from their foundations. Small cracks across some of the streets were reported, but they are not now visible. All brick buildings were damaged to some extent. A tank 2 or 3 miles to the east threw the water out on the northwest and southeast. Colonel La Motte, at the spawning station 5 miles north of Willets, stated that the water of a pool 8 to V2 feet in diameter and 2 feet deep splashed out on the south and southeast, wetting the pickets to a height of IS inches. It did not splash out in any other

direction- The valley is an old lake bed with ground water within 3 to 4 feet of the surface in April. (See plate 73B.)

At Hemlock, 14 miles east of Ukiah, the shock, according to a report by Mr. C. D. L. Bowen, had two maxima, the second being the stronger. A rotary motion was felt, but no damage was done.

#### CLEAR LAKE DISTRICT.

For the Clear Lake district to the east of the Upper Russian River Valley, the following notes are from a report by Mr. C. E. Weaver:

*Holland to Lakeport.* — Nothing of importance was observed along the road from Hopland to Highland Springs. At the latter place one chimney fell. No cracks nor fissures could be seen. From Highland Springs to Lakeport no cracks were seen, and upon inquiry none were reported. The damage to buildings was slight; only a few chimneys were thrown down.

At Lakeport several brick buildings and one frame building were partly destroyed. A brick building was completely destroyed and most of the chimneys were thrown down. Many chimneys not actually thrown were twisted, and in every case the direction of the rotation was clockwise. All 6 chimneys of the high school building were twisted thru an angle of about 20°. Clocks in general stopt. No fissures nor cracks are reported or were found. The town is built on alluvium.

*Upper Lake.* — The intensity of the shock is said to have been greater at Upper Lake than at Lakeport. There are, however, no brick buildings there, and only chimneys went down. No cracks nor fissures were formed. This town is also on alluvium.

*Laurel Dell* — A crack having been reported at Blue Lake, near Laurel Dell, Mr. Weaver visited the place, but found only a minor slide on the roadside. At Laurel Dell and Blue Lake Hotel chimneys fell. The first story of Laurel Dell Hotel, built of stone, was not affected. No cracks nor fissures were seen or reported between Upper Lake and Lakeport.

*Lakeport to Lower Lake.* — Between Lakeport and Kelseyville, a distance of 9 miles, a few chimneys were down along the road. Houses are few, however. At Kelseyville, on a wide alluvial flat, brick buildings were somewhat damaged, and chimneys generally were down. The shock was reported to be of about the same severity as at Lakeport. The shock was described by residents as having had first a north to south motion, then east to west, then a twist. One mile south of Kelseyville and half a mile to the west, at the place of Mr. McLaughlin on the Lower Lake county road, a crack was found in the alluvium out of which gas escaped, burning upon ignition. About one mile north are gas wells in the same kind of rock, the gas being obtained by boring to a depth of 165 feet.

About 3.75 miles south of Kelseyville on the road to Lower Lake, at the ranch of Mr. M. E. D. Bates, is a crack varying in width from 1 to 6 inches. It crosses the road about 200 feet below the house. At the right of the road going south it crosses the creek and can be seen no further. At the left of the road it passes up the hill toward Uncle Sam Mountain for about a mile, but is not continuous. Near the road two small trees standing on the crack have been partly uprooted and a fence post has been thrown out entirely. The rock thru which the crack passes is alluvium and a loose, unconsolidated conglomerate. It apparently does not pass thru the hard Franciscan rocks. In places there are as many as 10 parallel cracks, separated by intervals of 5 to 10 feet, which could be traced for only short distances. On the right side of the road, about 100 feet south of the cracks, stands a schoolhouse. It has been slightly tilted to the south. The chimney, made of terra cotta, is bent to the south. The chimneys on the house of Mr. Bates fell.

On the side of Mount Konocti, several large loose boulders were caused to roll down, but no landslides nor cracks were observed.

*Cache Creek Canyon.* — On Sunday, May 1, a large slide occurred on the side of Cache Creek Canyon. Mr. Weaver visited this and reports that the slide occurred about 4 miles below the junction of the north and south branches of Cache Creek. The creek here flows thru a canyon not more than 1,000 feet wide, with steep walls on each side. At the point where the slide occurred, the creek makes a bend. The rock which slid is a red sandstone. The distance from the creek to the point where the slide began is about 500 feet. The width of the slide is about 300 feet. It occurred on the south side of the canyon and dammed up the latter to a height of 90 feet. The water rose to that level and one week later, May 7, the dam broke and allowed the water to escape down the valley. Nearly all the material was carried off by the water.

At the base of the cliff where the slide occurred are several very large springs; it is stated by Mr. Brainard that springs were common at the base before the slide occurred. About 500 feet back from the upper edge of the slide there is another crack, having a width of from 2 to 6 inches. It is about 300 feet long and the mass of rock in front of it appears ready to slip. No other cracks were seen.

At Middleton the shock was not especially severe. The brick hotel was not injured, but some chimneys were down.

At the toll-house on Mount St. Helena no chimneys were down and the shock was not especially severe.

At Oat Hill, at an elevation of 2,000 feet, on a mountain slope facing east, Mr. J. J. Multer reports that no damage was sustained in consequence of the earthquake. The shock comprized two parts, of which the second was the stronger. The direction of movement was northwest and southeast.

*Vicinity of Upper Lake.* — Charles Miffiin Hammond says:

I live about 4 miles southeast of Upper Lake, in the approximate latitude of  $39^{\circ} 10'$  N. and longitude  $122^{\circ} 45'$  W., at an elevation above the sea of 1,350 feet, and about 50 feet above the surface of Clear Lake. The house is 45 by 90 feet, well built, and a story and a half high. In it I have a collection of about 70 clocks, of all ages, styles, and makes. These stand on mantelpieces, on shelves, on the floor, on bookcases, and some are hung on the walls. I have no absolutely correct time, but on the morning of April 18, between  $5^{\text{h}} 13^{\text{m}}$  and  $5^{\text{h}} 14^{\text{m}}$ , my wife and I, who were asleep, were awakened by a violent rocking of the house. We jumped to a doorway and stood there for about 2 minutes, the house gradually coming to a state of rest from its violent rocking and swaying, and a roaring noise passing off in a southwest direction. This direction is corroborated by some of the men on the place who were up at the time. They all said that they suddenly heard a noise in the trees as tho a heavy wind was blowing thru them, and that the rumbling past away to the southwest. There was only one maximum and the movement certainly came from the northeast.

I at once made an examination of the house. The southwest room showed the greatest disturbance. From the top of a small bookcase facing west a large china vase was thrown to the floor and smashed. On my desk, facing north, stood a spy-glass 2 feet high, which was tipped over to the southwest. In the southeast corner room, on a mantel facing southwest, a vase of flowers was tipped over to the southwest. Practically every one of my pendulum clocks had stopt, with two notable exceptions. In the southeast corner room, there stands on a small shelf facing northwest a very delicate Empire clock, which a sheet of paper put under one leg will stop. The clock kept on running, as it did thru all of the later earthquakes. In the southwest corner room there is another delicate clock standing on a bookcase facing southeast. This clock causes me a great deal of trouble, as the slightest variation in its level stops it; yet it was going after the main shock.

At 10 o'clock that morning there was another shock, which was not very perceptible, yet it caused the above clock to stop, and also a few others. At  $11^{\text{h}} 40^{\text{m}}$  I happened to be in the house starting the stopt clocks for a second time, when there came a third shock which again caused some of the clocks to stop.

On May 6, at  $8^{\text{h}} 10^{\text{m}}$  p. M., a very violent shock came from almost due east. We were sitting on the piazza, and it came without a second's warning. I judged it to be fully as severe as the one of April 18, but it lasted only about 10 seconds. In the southeast room, from the same mantel, a small wooden clock was thrown out on the floor to the southwest.

In the southwest room the same spy-glass was upset toward the northeast, and from the top of the tall bookcase, from which had before been thrown the china vase, a bronze figure a foot high was precipitated to the southwest. In the hall, on a bookcase facing west, a small wooden clock was tipped over to the east against the wall. At 9 o'clock that evening there was another shock almost as heavy as the first one, but by that time I was too rattled to take much note of it, especially as I had not started the clocks up again. But the next morning I went at them, and found that in some cases the pendulum had been swung out of the wire loop from the escapement. I tried to locate the direction of the quake from the condition of the clocks, but found that they had stopt indiscriminately, without regard to length of pendulum or direction. They have pendulums ranging from a few inches long to several feet. No plaster was cracked in the house, but many pictures were out of line, and the quakes of May 6 broke off two of my chimney tops at the roof line, the southwest corners of both being moved about 0.75 of an inch in that direction.

In the Rossi-Forel scale, I placed the shock of April 18 in class VIII and those of May 6 in class VII. In none of the shocks was any disturbance noticed on the waters of the lake, nor was there evidence of there having been any waves, yet on the 18th a plank connecting my floating boat-house with the bank was found with its outer end in the water, showing that the boat-house had been pulled away from it. This plank ran about east and west. In all of the shocks the house seemed simply to sway backwards and forwards. There appeared to be no up and down movement. In the cellar under the house the milk was thrown from the pans in a northeast and southwest direction.

*Bartlett Springs* (Mrs. M. E. Clark). — My husband past the night of April 17 at Upper Lake, where the shock was quite severe, but my son, a boy 16 years of age, was on the ranch, 5 miles northwest of Bartlett Springs. The shock was severe enough to stop the clock. He and another boy felt the prolonged tremor and the rocking of the house. They were dressing when the shock occurred. Nothing, however, was reported as having been knocked over, nor was any milk spilt from pans. At our nearest neighbor's, 4 miles northwest of our ranch, nothing was known of the earthquake till it was mentioned to them 3 days after the event, altho a member of the family thought he felt something. At another neighbor's, 5 miles northwest of here, at Horse Mountain, the wife was awakened but not the husband. At Twin Valleys Ranch, a smart shock was felt and the clock was stopt.

*Lower Lake* (W. C. Goldsmith). — No chimneys were thrown down in the town, but 2 chimney tops fell to the southwest at a point about one mile northeast of the town. Mr. Weaver reports that Lower Lake is on Eocene sandstone, and that the shock was much less than at Lakeport or Upper Lake.

*Sanhedrin, Lake County* (V. L. Frasier). — This place is in a small alluviated valley surrounded by mountains. One shock was felt which was not severe enough to throw chimneys. The motion was from northwest to southeast. Some men in a tunnel in solid rock, 800 feet below the surface, did not feel the shock, and people living on the surrounding mountains report the shock as much lighter than in the valley.

In the district about Knoxville, Mr. Weaver reports that a few chimneys at ranch houses fell, but that no severe damage was occasioned. To the east of the crest of the Coast Ranges, in the latitude thus far considered, observations indicative of the intensity of the shock become more scattering, and people generally attached little importance to their experiences of the morning of April 18.

#### FORT ROSS TO BODEGA HEAD.

We return now to the coast south of Fort Ross. An examination of the coast between Fort Ross and Bodega Head was made by Prof. J. N. LeConte and Mr. A. C. Wright. The portion of their report dealing with the distribution of intensity follows:

From Fort Ross the line of the earthquake fissure was followed south to the point where it passes into the sea. From this point we followed the beach for 8 miles. Several slides were seen about 3 miles south of the Fort. One of these was of great size, being between



300 and 400 feet in height. These are evidently old slides, and the amount of material brought down by the recent earthquake, though large, is insignificant compared with the size of the scar. At Rools Landing the beach was abandoned, and the wagon road was followed to Davis Mill at the mouth of the Russian River. The earthquake here had caused several thousand dollars' damage to trestles on the logging railroads. No buildings were moved on their foundations, only chimneys being thrown down.

From this point the road along the bench above the sea was followed 12 miles to Bodega Bay (see map No. 4). The country is sparsely settled. Only three or four houses were past, and these were uninjured except for broken chimneys. Near Bodega Head the bridge over Salmon Creek was somewhat twisted. Just beyond this a good-sized hotel, previously used as a summer resort, was badly wrecked by the earthquake. It was moved on its foundations, and rendered unfit for habitation. This building was close to the sand-dunes and probably rested on sandy deposits. The barn was completely wrecked. A few hundred yards beyond this a small mud-flat extends from the sea up to the road. Curious mounds of mud, shaped like truncated cones, were thrown up by the earthquake. Subsequent examination showed that the line of the earthquake fissure must have past near this spot.

*Duncan's Mills* (J. Parmeter). — On the Russian River, when fisherman tried to seine fish after the earthquake of April 18, their nets were torn to pieces by snags, etc., where there had formerly been no obstruction. Large trees that had been buried in the bed of the river were lifted up by the convulsion, while other trees vanished that had been in sight. Low places in the river bed were made high and *vice versa*.

The bottom of the river appears to have dropt 2 feet all along by Duncan's Mills for 2 miles; and at the mouth of the river, where there used to be water 12 or 14 feet deep, there is now only 2 feet, and a riffle till boats can hardly cross, for a length of almost a mile. For over a mile there is now a strong current, where there used to be quiet water with very little current. A man who was by the river, near Monte Rio, when the earthquake occurred, told the Parmeters that he saw the muddy bottom of the river rise to the surface, and the water ran off over the banks. The bottom was the highest where the water had been 8 or 10 feet deep; then it settled back. A road and fence moved 10 feet. On the other side of Russian River from Duncan's Mills, 200 or 250 feet back from the stream, the earthquake made many holes thru which black sand and water blew up. Such blow-holes were made all along this river. Between the river and the ruined hotel at Duncan's is an irregular crack about 20 feet wide, 80 feet long, and 1.5 to 4 feet deep, with a blow-hole 4.5 feet wide and 2 feet deep where coarse river gravel came up.

(R. S. Holway.)—One hotel at Duncan's Mills was completely wrecked and other buildings were much damaged. Along the river there were several cracks in the alluvium.

(I. E. Thayer.)—The shake was of great severity on the Russian River at Duncan's Mills, and totally destroyed a large hotel. Several small houses were thrown from their foundations.

#### TOMALES BAY TO BOLINAS BAY.

BY G. K. GILBERT.

The following data upon intensity were gathered, with slight exceptions, between April 23 and May 12, 1906. In their arrangement the order followed is: (1) The line of the fault from south to north; (2) the towns of the Rift belt; (3) the peninsula west of the Rift; (4) routes of travel east of the Rift; and (5) distribution.

*Along the Fault.* — Mrs. Steele's farm buildings, near the head of Tomales Lagoon, stood in a very narrow fault-sag which was traversed by the fault-trace. At this point the trace consists of a group of cracks 10 to 20 feet broad. The barn, resting partly on the ground traversed by these cracks, was demolished so that, as I saw it, it lay in ruins. The house, standing only a few feet to the east of the fault, was thrown from its underpinning and a wing was partly separated from it.

The buildings of E. E. Strain, 1.5 miles north of Bolinas Lagoon, stand about 20 rods east of the fault-trace, the house being on a hill and the other buildings on sloping alluvium at its base. The house did not leave its brick foundation, but the foundation was cracked. Chimneys were thrown down. The other buildings were thrown from their underpinning, moving eastward. Milking was in progress in the barnyard. Some cows were thrown down, and Mr. Strain himself was thrown to the ground, but rose and grasped a tree, of which he retained hold with much difficulty.

Daniel Bondiotti lives 3.5 miles north from the head of the lagoon, and his buildings are about 20 rods east of the main crack. His house was shifted 3 feet toward the fault and his barn moved in the same direction. Men engaged in milking were thrown in a direction away from the fault — that is, to the northeast—and cows were also thrown in this direction.

At a barnyard near Bondiotti's, and east of the fault, a milker was thrown to the west — that is, toward the fault.

At Beisler's ranch, a short distance north of Bondiotti's, the fault-trace is in two parts, of which the western or main part passes under the barn, and the eastern between the house and the barn. Mr. Beisler was milking a cow at a point within 6 feet of the west branch, and on the southwest side. He was thrown to the southwest, arose, and started to go in the opposite direction, when he saw the crack in the ground; he then turned and was again thrown, but with difficulty reached a fence 10 or 15 feet away before the end of the shock. His house and buildings were strained, but they did not collapse, and their shifting was slight. The greatest shifting was of the main part of his barn, which stood between the branches of the fault and moved about 2 feet to the northwest. A water-tank near the fault was shifted slightly but did not overturn. At both the Bondiotti and Beisler ranches the surface of the ground has considerable slope and it is probable that bedrock is not far below the surface.

The buildings of the Dickson ranch, 2.5 miles south of Olema, are about 0.25 mile east of the fault-trace, standing on a hillside presumably on firm ground. They nearly all slid southwest — that is, downhill and toward the fault. The barn, an old building, collapsed.

At the Bloom place, a mile south of Olema, the buildings stand 30 or 40 rods east of the fault, and are on firm ground. The injury to buildings was here comparatively small. A water-pipe by which water was brought from a point on the opposite side of the fault was broken in many places, being at some points pulled apart and at others telescoped. At one place it buckled so as to project several feet above the ground. After being repaired, the pipe was found to be shorter than before, the difference being estimated at about 5 feet. I did not examine the course of the pipe, but from its general direction I infer that it crossed the fault obliquely from south to north, and that the shortening was the direct result of the horizontal throw of the fault.

Mr. Payne J. Shafter's place is near the village of Olema. The fault-trace is close to the house and other buildings. These stand on a bed of alluvium which is probably supported by bedrock at a short distance below the surface. In the barnyard men were milking, and were thrown violently to the ground, along with the cattle. The buildings were much damaged. During the earthquake a cow fell into the fault-crack and the earth closed in on her, so that only the tail remained visible. At the time of my visit the tail had disappeared, being eaten by dogs, but there was abundant testimony to substantiate the statement. As the fault-trace in that neighborhood showed no cracks large enough to receive a cow, it would appear that during the production of the fault there was a temporary parting of the walls.

Mr. Skinner's ranch is 0.5 mile west of Olema and on the line of the fault. The trace passes within about 10 feet of the house and within 2 or 3 feet of the dairy, and runs under a portion of a large emv-barn. The house stands southwest of the fault-line, and is on the block which moved northwest. The house itself was shifted northwest with reference

to the ground. (See fig. 22.) A granary standing 100 feet farther west than the house was shifted southward about 3 feet. The movements of the house and granary were thus in nearly opposite directions. The dairy remained on its foundations. The barn was not shifted on the earth block supporting its greater part, but was dragged along over the other block. Movables in the buildings were thrown about with violence; dishes, etc., were broken; but no buildings were destroyed and all were afterward repaired and used. A circular water-tank standing on a trestle about 12 feet high, approximately 100 feet northeast of the fault, was uninjured, and seemed to be absolutely undisturbed. In the barn-yard, which was traversed by the fault, cows were assembled and several men were engaged in milking. Cows and men were all thrown to the ground, the direction of their fall being northeastward and away from the fault. This direction was also downhill.

The road from the Skinner place to Olema crosses a small creek, and near the bridge is a deep pool. Water from this pool was thrown out to the southwest, being carried across the road a total distance of 3 or 4 rods.

*Bolinas.* — At the south end of the peninsula is a sloping plain carved by the sea when the land stood lower than it now does. Its general form and relations are shown by the contours of the map, fig. 10. This plain originally extended at least as far as the shore of Bolinas Lagoon, but east of Paradise Valley it has been modified by changes associated with the Rift. The line of Paradise Valley, when extended southeastward parallel to the fault-trace, marks approximately the limit of the Rift in that direction, and all the land between it and the fault-trace is broken into blocks which have been diversely faulted and tilted. As some of these blocks retain the smooth upper surface which they received as parts of the plain of marine denudation, their present attitudes serve to express the nature of the dislocations. Two small blocks facing the southern part of Bolinas Lagoon retain approximately their original height, but are tilted at different angles toward the northeast. A third block, too narrow to be caught by the map contours, has dropt 50 feet lower and is tilted at a still higher angle toward the northeast. A fourth and much larger block, itself involving minor dislocations, slopes southward from a point opposite the head of Paradise Valley to the delta of Pine Gulch Creek. The upper part of the village of Bolinas lies in a curving fault-sag among these dislocated blocks, and another portion stands on the delta of Pine Gulch Creek. In the fault-sag, where the ground was much cracked, nearly all the houses were either shifted on their foundations or else thrown from their foundations. There was great destruction of furniture and other breakable articles. In some cases people were thrown from their beds, but none were seriously injured. Three buildings which had stood on stilts along the shore of the lagoon were tipped toward it so that their lower edges came within reach of the tide. Several buildings were so badly injured that they were afterward torn down by their owners instead of being repaired. Just outside the fault-sag, and only a few rods distant, a group of houses stand on higher ground, and these were comparatively uninjured. They were not moved on their foundations, and in one instance the chimneys were not thrown down.

In the northern part of the town, standing on the delta of Pine Gulch Creek, about half the buildings were thrown from their foundations, and here also the destruction was greater on low flat land than on higher ground.

*Olema.* — The village of Olema is about 0.5 mile east of the fault-trace and at the edge of the Rift belt, the greater part being included within the Rift. The residence of Mr. Pease, standing on alluvium, was shifted south about 2 feet, falling from its supports. It was very badly wracked, and was eventually torn down. A neighboring piece of alluvial land bordering Olema Creek sank about 2 feet. The hotel owned by Mr. Nelson, standing on-higher ground, was somewhat, wracked but was not shifted. A house next door moved 2.5 feet to the northeast. A house opposite moved 2 feet to the northwest. Another house opposite fell from its supports, moving southwest. A neighboring stable

was wracked so as to lean to the southwest. A church moved 3 feet to the southwest, that direction being downhill. Probably half the houses in the town were not shifted from their foundations. Of two bridges over Olema Creek, one was shaken to pieces. A lady in the hotel was thrown from her bed by the shock.

*Point Reyes Station.* — The village at the railroad station of Point Reyes is about 0.5 mile northeast of the fault-trace, and stands on a low bench of apparently firm ground. It is probably just outside the Rift belt. The schoolhouse, a 2-story building standing on a brick foundation wall, was shifted 2.5 feet to the south. A stone building used as a store was thrown down, the walls falling toward the southeast. The hotel barn was shifted 20 inches toward the south and a few other buildings were shifted, the distances, so far as observed, being less. Brick chimneys were generally thrown down. A large shed was wrecked. In all buildings furniture was shifted, objects on shelves were thrown down, dishes were broken, etc. An engine and three cars standing on the track were overturned toward the southwest. A long wood-pile was thrown down toward the southwest.

*Inverness.* — Inverness is a village of summer residences on and near the southwest shore of Tomales Bay. The upland of the peninsula there closely approaches the bay. The village occupies two narrow valleys normal to the shore, and a mesa between them. Its site is within the Rift, and both valleys and mesa were traversed by many cracks, of which some had the character of branch faults. All the houses were of wood. About half of them were shifted on their foundations. To a certain extent the direction of shifting was determined by the slopes of the ground, the houses moving downhill; but where that factor did not control, the movement was toward the west or southwest. In one instance I noted a southwestward movement of several feet uphill. A few houses in the southern or "first valley" near the beach were demolished, or so badly injured as to be torn down. Several houses on the mesa were so badly injured as to require practical reconstruction. As the most serious injury was to houses thrown from their foundations, it is probable that the jar of falling was an important factor. It is related that a number of persons were thrown violently from their beds, but there were no serious personal injuries. Of a series of bath-houses standing on the beach, some remained unmoved; others were tilted because of the yielding of their slender supports; and one was turned over on its side without the breaking of the pins on which it stood. It fell to the northwest. A water-pipe following an east-west (or northeast-southwest) road on the mesa, and buried about 1 foot, was buckled at two points so as to be lifted above the ground. I saw no earth-cracks near these points. (See plate 71A.)

The phenomena connected with five water-tanks seem worthy of special mention, because *the* simplicity and symmetry of the structures were such that the directions of displacement must represent closely directions of earth movement. A large tank containing water for the village supply stood on the mesa about 0.5 mile from the shore of the bay, its foundation rising a little above the ground. It was thrown in a direction almost due north and completely demolished, the planks and staves constituting its sides and bottom strewn over a space of 50 feet. (Plate 72A.) The other four tanks were situated along the base of the hill between Inverness and the head of the bay, and held water for the mill. Each one stood on a square pedestal of braced timbers about 10 feet high. The first tank in Inverness fell to the west, its pedestal yielding and being tilted to the west. (Plate 72B.) The second tank next fell to the southwest, and tank and pedestal were both tilted to the southwest. The third tank was shifted 4.5 feet westward on its pedestal, both tank and pedestal tilted to the southwest. The pedestal of the fourth stood unchanged, and the tank was tilted to the west-northwest, being overturned as it fell. (Plate 71B.)

Along the first 2 miles of travel, covering a right-angle bend, road-cracks were numerous and often large. There were many cracks in the earth from the road cliffs. Beyond that point there was no evidence, and though the road-cracks were frequently seen they were all

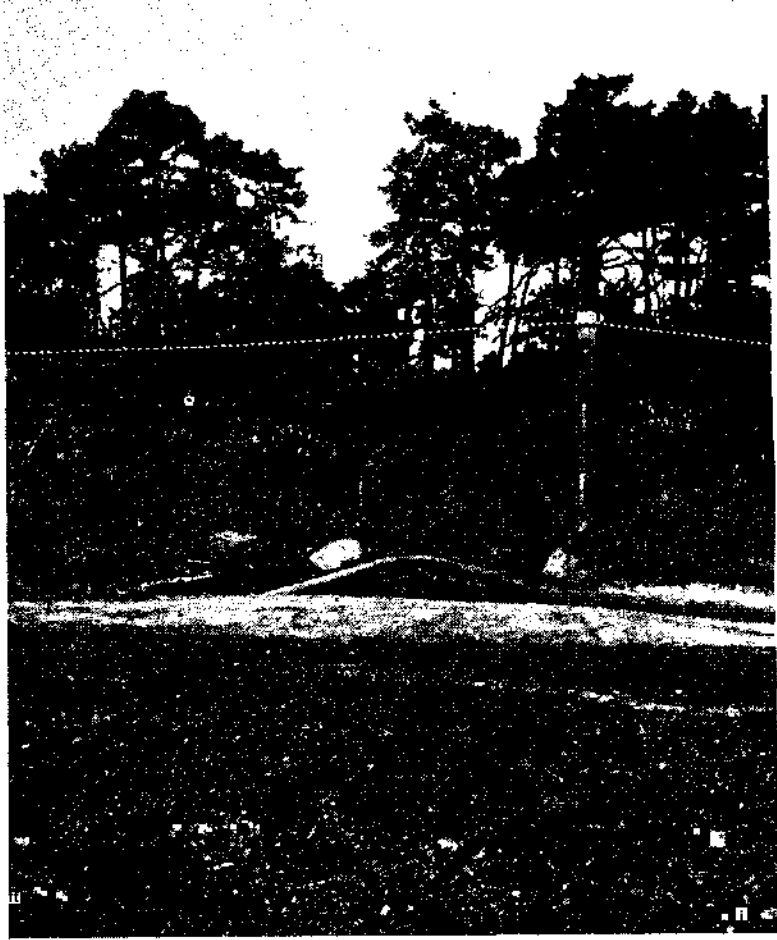

A. Buckled water-pipej Inverness. Gi Ki Q.



B. "Wrecked water-tank, near Inverness. Gh E. G.



A. Ruin of Inverness reservoir, a circular tank which before earthquake stood in fine. Parts of shed also lie in foreground, about 50 feet from original position. G. K. G.

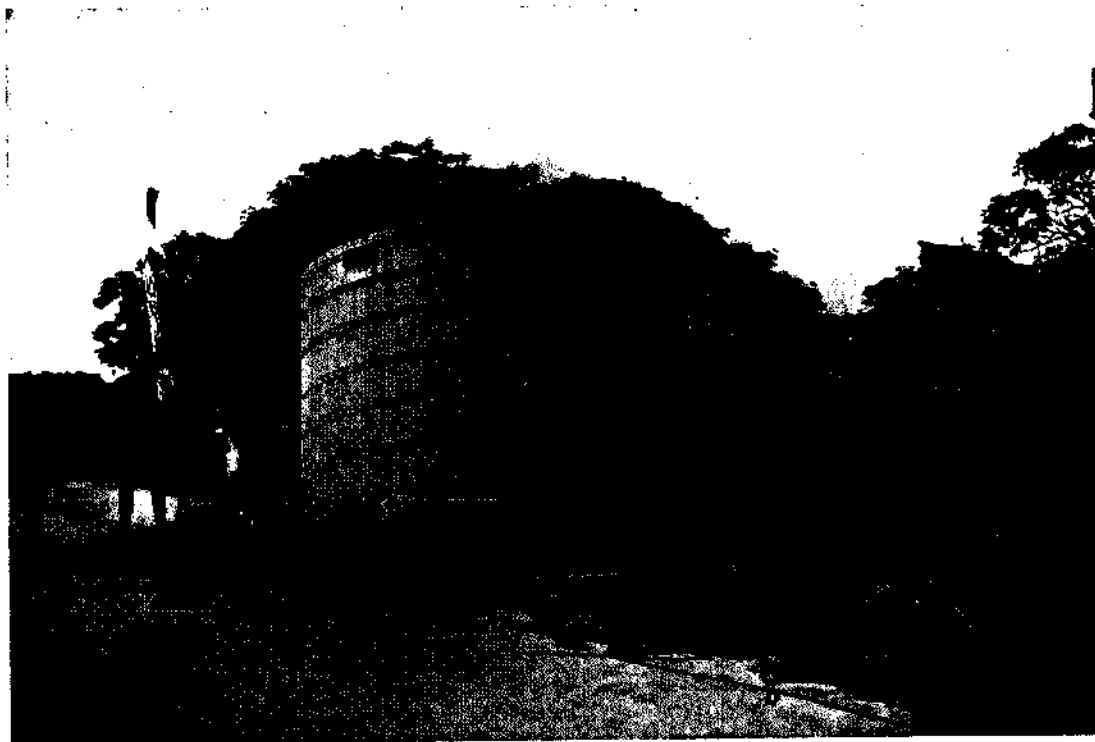

B. "Wrecked water-tank near Iawraets. Q. K. G.

small. In the neighborhood of Limantour Bay (indicated on some maps as Drake's Estero) there are a number of ranches. Most of these showed broken chimneys; but at a ranch west of the head of the bay 2 brick chimneys stood uninjured. At Point Reyes Post-office, the main residence building was thrown from its foundation of props and shifted 2 feet westward, being badly wrecked. Other buildings of the same group were not shifted, and 2 water-tanks on high frames seemed to be uninjured. At Mr. Claussen's ranch, south of the Post-office, 2 buildings were shifted a few inches to the south, that direction not being determined by their structure but being diagonal to their sides. The chimneys were thrown down, plastering cracked, furniture shifted, and many dishes broken. A picture was reversed so as to hang face to the wall. Mr. Claussen, being out-of-doors at the time, was thrown down. Some cows were also thrown down.

At the U. S. Life Saving Station, on the coast 3 or 4 miles from the light-house, brick chimneys were broken but not thrown down, furniture was moved, dishes were broken, and the filled ground about the house settled several inches. A mast standing in the sand was said to have been heaved up several feet, but its position had been restored before my visit. My informant said that he was standing when the shock came, and sat down to avoid falling.

At Point Reyes Light-house the heavy mechanism controlling the light was shifted several inches on its base. A lens "jumped" from its ways. It was so held in place by dowel pins that its movement required a lift of about 2 inches. The only injury to buildings was from the cracking of chimneys. Wooden tanks with water were not shifted. One of the light-house keepers stated that after the shock he looked from the window of his room, which commanded a portion of the sea near the beach, and saw the water "boiling," but there was no change of the nature of a wave.

*Sunshine Ranch and Vicinity.* — I drove to the summit of the ridge southwest of the head of Tomales Bay, finding abundant and strong road-cracks all the way to the crest, which is about 1.5 miles from the fault-trace. There were also a number of landslides in this region, and a considerable number of trees were broken or uprooted. There were few houses. The only ranch visited, known as the Sunshine Ranch, and occupied by Mr. Silver, suffered as severely as the houses of Inverness and Bolinas. The house moved southwest 3 feet and was badly wrecked. The dairy was thrown from its foundation and wrecked beyond repair. The barn, a large building, fell northward downhill and collapsed.

*Bear Valley.* — I drove from Skinner's ranch southwestward thru a pass in the upland, covering two-thirds of the distance to the coast, and reaching a point about 3.5 miles in a direct line from the fault. The most striking evidence of violence was shown by the trees. A few were thrown down, including oaks and spruces; branches were broken from others and some spruces had lost their tops. Most of these phenomena were seen within 0.5 mile of the fault. In the same region are a few summer cottages, which sustained little injury, only the fall of chimneys being noted. The club-house of the Country Club, situated about 1 mile from the fault, lost chimneys but was not shifted. One of its barns was wrecked, falling downhill in a southerly direction. In this region I saw only a few cracks other than road-cracks, and the road-cracks were unimportant.

*Seven Lakes.* — Crossing the main divide of the peninsula near the head of Pine Gulch Creek, I followed a road to the vicinity of the coast, a district known as Seven Lakes. As the trip was made 5 months after the earthquake, the evidence from road-cracks had disappeared. There were a few landslides, and a number of cracks already mentioned (page 75) testified to movements of large blocks of ground; but I think these were due to a peculiarly sensitive condition of the country rather than to the violence of the shock. At 2 ranch-houses not far from the ocean, chimneys were broken but buildings were not shifted. A few dishes were thrown down, but otherwise there was no injury to movables or houses.

*West of Bolinas.* — Driving 2 miles west of Bolinas, and looking at buildings from the road, I saw very little evidence of injury. At a distance of about 0.5 mile from the fault a chimney was broken at the roof, but not lower down.

*North of Point Reyes Station.* — I drove a few miles north and east from the station, over a high terrace separating the upland from the bay at the east. The injury to buildings was found to be much less there than at the station, and not all chimneys were thrown down. A large barn was seen to lean as tho some of its props had given out; two water-tanks were wrecked. A few cracks were seen in the ground, but they were much smaller and less numerous than at a similar distance on the opposite side of the fault.

*Sausalito to Point Reyes Station.* — Observation was made only from the car-window. The towns from Sausalito to Fairfax showed no damage more serious than the loss of a portion of the chimneys. The same remark applies to buildings seen along Papermill Creek as far as Garcia. Beyond Garcia the creek has several reaches of alluvial bottom, and some of these were so badly shaken that the railway embankments and trestles had to be repaired. Railway traffic to Point Reyes was interrupted for about 10 days.

*Ross to Bolinas.* — This road was driven over 8 days after the earthquake. In the village of Ross houses were not shifted. The principal injury is to brick chimneys, of which probably more than one-half fell. A group of stone buildings on a hill lost heavy stone chimneys, and there was injury to a tower. Some stone fences on alluvial ground were in part thrown down. These fences were of undrest stone, loosely piled. In San Anselmo most of the brick chimneys were broken, but other injuries in that town and in Fairfax appear to have been slight. Along the road from Fairfax to Bolinas Ridge, the only evidence of the earthquake consisted of small road-cracks, with occasional stones fallen from the road-cuts. These evidences of moderate disturbance continued down the western slope of Bolinas Ridge to the edge of Bolinas Lagoon. A house standing in the middle of the valley, probably 0.25 mile from the main fault, showed from a distance evidence of considerable disturbance. Its chimneys were broken, the house itself had probably been shifted on its foundations, and one of the outhouses was out of plumb, apparently having slidden downhill toward the northward. The house was not visited, but was merely seen from the road.

The general fact brought out in this drive was that the region about Ross and Fairfax experienced a shock comparable with that at Berkeley, and there was no evidence of high intensity until the fault-trace was closely approached. Landslides were not seen east of the lagoon, and the road-cracks east of the lagoon were not important.

*Mill Valley to Bolinas.*—At Mill Valley the visible injury was chiefly to chimneys. Extended enquiries were not made; but no reports were heard of destruction to furniture. The houses were not shifted. The buildings at West Point, on the Tamalpais Railway, did not suffer; and I was told that there was no injury from the earthquake at the hotel on the summit of the mountain. From crags on the south slope of Mount Tamalpais, stones were detached and rolled down the slope. The same thing occurred near Willow Camp. From West Point to Willow Camp there are no buildings, road-cracks were small, and no landslides were seen. A few stones fell to the road from the side of the road-cut. A ranch 0.5 mile east of Willow Camp showed no injury to buildings. At Willow Camp all brick chimneys fell, several houses moved a few inches toward the southeast, and dishes were thrown from shelves. A tall house 0.5 mile to the northeast was apparently not disturbed, and retained its brick chimney. Farther up the shore of the lagoon, and nearly opposite Dipsea, some farm buildings seemed to have been so disturbed as to be thrown out of plumb. They were not visited. At Dipsea 2 summer cottages were moved a few inches to the southwest, or were wracked in that direction. The hotel was swayed in the same direction, but the building withstood the shock. The barn, a rather large building, was thrown from its underpinning, falling toward the lagoon.



*Distribution.* — The variation of intensity with the character of the geologic formation is evident at various localities, but most conspicuously at Bolinas, where the destruction on alluvium at the bottom of the little valley was very much greater than on the hills immediately adjacent. Nevertheless, the data are not sufficiently full for a satisfactory discussion of this phase of the distribution of intensity, and I have therefore tried to make allowance for differences of formation, and in that way obtain a general conception of the distribution of intensity with reference to the fault and the Rift.

The intensity was greatest on the line of the fault, but did not diminish rapidly toward the east and west within the Rift belt. In a general way the intensity was greater in the Rift belt than on either side. On the east it fell off rapidly — almost suddenly — at the limit of the Rift. On the west it fell off gradually, being nearly as high at a distance of 0.5 mile or 0.75 mile from the rift as at the edge of the Rift. In a general way the intensity west of the Rift was greater than at the east. My conception of the distribution on a line normal to the Rift is expressed by the following curve (fig. 50), but this should not be subjected to measurement, as its elements are not definitely quantitative. It is a generalization from data that are heterogeneous and by no means complete.

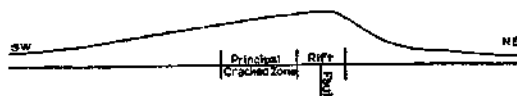

In a general way the distribution of high intensity follows the distribution of bedrock cracks. Inverness, where the injury to structures on firm ground reached a maximum, is traversed by important bedrock cracks, some of which are to be accounted as branches of the main fault. The high ridge west of the main valley, over which the intensity was nearly as great as along the Rift, was also characterized by many important bedrock cracks, and by a general derangement of the underground circulation of water. The district east of the Rift, where the intensity rapidly diminished, was practically exempt from bedrock cracks, and its underground circulation was not disturbed.

FIG. 50. — Curve illustrating distribution of intensity in relation to fault-trace and Rift. The height of curve above horizontal line represents intensity.

*Notes by other observers* (R. S. Holway).—A bridge about 0.75 mile southeast of Point Reyes (toward San Francisco) went completely down, causing several days' delay to trains. The track had had several horizontal bends of a few inches.

The "fills" across the arms of Tomales Bay generally sank from 2 to 8 feet. The 1,000-yard fill about 2 miles north of Point Reyes Station sank from 6 to 8 feet; as did the next fill, which is some 500 feet long. In one or two instances the pile-supported bridge in the middle of the fill remained at grade. Just above Hamlet a trestle-work which had been filled in settled, leaving the trestle-work some 2 feet above. The bottom of the bay in these arms is usually sand.

At Hamlet quite an extensive landslide has started in the hillside above the track. The railroad cut is in old rock, and the arch of the head of the slide is some 70 feet above the track. The country wagon road has been carried away by the slide for possibly 100 yards.

Miss Margaret Keating, a teacher at Marshall's, just at the close of the earthquake saw two waves coming from the opposite side across the Bay; that is, the length of the wave was parallel to the main Rift. The waves were from 6 to 8 feet high. The waves came nearly to the top of the trestle, and also up to certain willows which she indicated, both points roughly indicating a wave of the height she mentioned.

At Marshall's a hotel and a stable built on the west side of the track and on underpinning, resting in the tidal flat, went easily and gently into the bay. The occupants of the hotel did not realize that the hotel had fallen, but at first thought the water had risen. At the post-office store goods were thrown from the west wall, but scarcely at all from the east.

George H. Covert, of Cypress Grove, about 0.5 mile north of Marshall's, states that on the morning of April 18 he saw a wave 8 to 10 feet high, and white-capped, come broadside on to the east side of the bay immediately after the shock. That is, the wave-crest was parallel to the axis of the bay. The ground has a gentle slope here, and the wave did no harm. Mr. Covert gave a clear, intelligent account, and fully corroborated the testimony of the teacher at Marshall's.

The island in the bay nearly opposite Hamlet was visited, but no sign of the fault was found. Tomales Point, west of the bay, was crost at the "Gum Trees." Small landslides were found on the bay shore on the ocean side of the point at various places. On the peninsula no cracks were found. At one place on the ocean shore a projecting granitic, rocky spur was much crusht and ground in the narrow neck connecting it with the mainland. The spur is about 30 feet high and 50 feet long.

Prof. E. Knowlton gave an account of the damage caused by the earthquake at Bolinas and vicinity in the public press, extracts from which are here quoted:

Along the main street of Bolinas stand most of the houses, not far from fifty in number and all frame. Of these about two-thirds were heaved, slid, tipt, and shattered into uninhabitable condition. No fatality occurred. As in San Francisco, most of the chimneys came down, but the shock was much more severe in Bolinas than in San Francisco. Along the bay shore were 7 buildings. Of these 6 went over or down. At the Flag Staff Inn the tipping of the house has thrown it so far east into the bay that one may sit along the upper edge of the parlor floor and fish in 4 feet of water along the opposite edge of the same room. The village church was pitched forward and downward, falling 3 feet; pews were torn loose and pitched about, with walls and ceilings cracked and shattered. The large new 2-story building now containing the Post-office, 50 x 30 feet, was swung 5 feet off its concrete foundation at the north end. Back of the Steele place, near the north end of the lagoon, the hillside started eastward toward the lagoon, bulged upward, and cracked into several fissures from 30 to 100 feet long and from 5 to 18 inches wide. The great ocean bluffs along the south and west of the entrance to Bolinas Lagoon, some 165 feet high, crumbled and fell, crashing down upon the ocean beach and reducing the slope of the bluff to half its former angle. The two bluffs along the stage road from the head of the lagoon to the town also broke and fell from 40 to 60 feet, completely blocking the stage road along the lagoon beach.

#### BETWEEN THE COAST AND SANTA ROSA VALLEY.

*Tomales, Marin County.* Population 300. (R. S. Holway.) — The Catholic Church, a fine-looking stone building, was completely wrecked (plate 81D), as were the brick bank and saloon, and a stone store building. Several frame buildings were pitched from their foundations and wrecked. A brick chimney on the United States Hotel was pitched north and went over the porch, falling in the street. All chimneys were down. Cracks were reported in the street and near the depot. Just north of the depot there was an extensive landslide along the railroad, which threw one track over the other. (Plate 129 A.) hi the cemetery 18 square monuments fell north or south, 11 north, 3 south; 3 square monuments fell east or west. No monuments of any size were left standing except 3 heavy and relatively low rectangular stones. In another cemetery, 0.5 mile out of town, 20 monuments fell north and south, and none east or west. Four monuments were left landing. A small spring started in the basement of Mr. Cornett's house, which stands on the hillside near the depot. A stone dwelling 1.5 miles southeast of the town was completely wreeke.l, killing two people. (Plate 81c.) At Freeman's, 3 miles north-east of Tomales, a large landslide was caused by the shock. (Plate 129B.)

(Mr. Dftnell.)—At noon, April 17, the plaster fell in a store and broke the show-cases.

*Dillon'u Htarh* (R. S. Holway). — Chimneys were thrown from the small cottages, but one chimney on the main building remained standing.

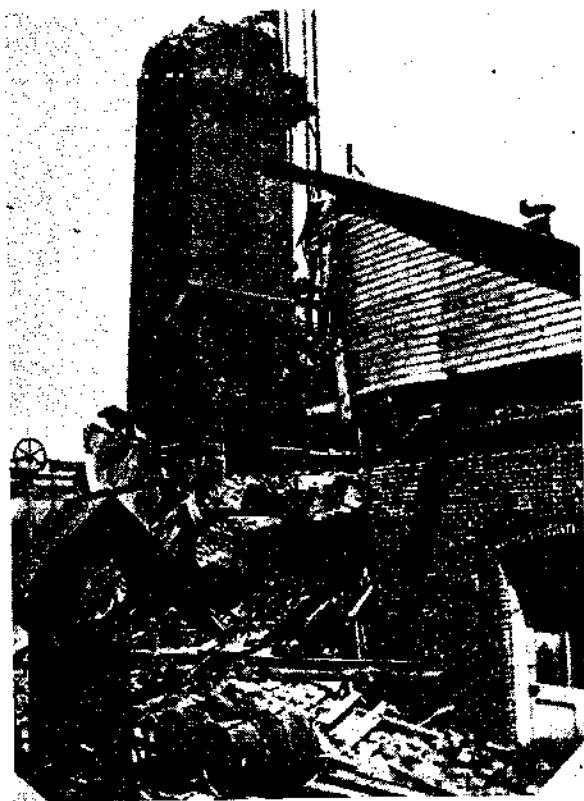

A. Cold-storage plant, Petaluma



B. Buoiuer Hotel, Willets. E. S. H.



C. Corner Main and Washington Streets, Petaluma.

*Tomales to Petaluma* (R. S. Hoi way). — Route, eastward to corner south of Two Rocks, and then southward to Walker Creek; thence eastward to Petaluma.

The stone house which fell and killed two girls is on this road, less than 2 miles from Tomales. Chimneys are generally down, but there are several exceptions. Between the lagoons (5 to 6 miles south of west from Petaluma) increased flow of spring water is reported. No cracks are reported in the low alluvial land around the lagoons nor in Chileno Valley.

*Valley Ford, Sonoma County.* Population 300. (R. S. Holway.) — There are only 3 brick buildings in the village. One entire wall of the bank fell; other walls were partially wrecked. The walls of the other two buildings were partially wrecked. A large frame house just west of town shifted from its underpinning and was badly wrecked. General loss of chimneys and minor damage to small buildings resulted from the shock. There are quite a number of cracks in the flat valley-bottom adjacent. A landslide of several hundred yards in length but of very slight movement is found on the side of the valley directly east of town. The slide has moved just enough to make a furrow-like ridge on the lower side and has developed cracks on the upper side. Other small slides occur in the vicinity.

(H. M. LeBaron.)—Valley Ford is about 25 feet above tide water, and there are rocks near the surface in many places. Chimneys and objects were thrown north and south; the motion of the shock was north and south; and no vertical movement was felt. Brick buildings were partially destroyed, and many chimneys were thrown down. The foundations of many wooden buildings were damaged, some foundations giving way entirely. A large, well-built wooden residence of two stories was thrown to the south 3 feet and to the east one foot, and caused to drop down 3 feet.

*Bloomfield, Sonoma County.* Population 200. (R. S. Holway.) — This village is on the north side of the little valley running eastward from Valley Ford. The 3 brick buildings, two stores and a dwelling, were wrecked. Every chimney but one reported down. Several frame buildings shifted on their foundations. The cemetery is very badly wrecked; about 80 per cent of the larger stones fell. Of square monuments of approximately the same class, the direction of fall was north 11, west 14, south 8, east 0, south-east 1, total of this class, 34.

*Bodega, Sonoma County* (H. C. McCaughey).—The town is on a hill slope and creek-bottom in a valley surrounded by hills. Chimneys and objects were thrown southerly. Several houses were shifted on their foundations, and all chimneys were thrown. Good frame buildings with strong foundations were not hurt. There are no brick buildings in the place, but a mile from town there is a brick bark-drier. Altho this building is small and the brick work was bound together with iron rods, it was thrown into a heap.

#### SANTA ROSA.

In the section of the Coast Ranges inland from the coast, between the latitude of Healdsburg and the Bay of San Francisco, Santa Rosa first claims attention. This city, with a population of 6,700, suffered relatively more than any other place in California, except perhaps Sebastopol and Fort Bragg. Prof. R. S. Holway made a study of the effects of the earthquake at Santa Rosa and the surrounding territory, and an excellent report by this observer follows:

Santa Rosa lies on the eastern side of Santa Rosa Valley, which is here some 7 miles wide. The valley floor is a gently sloping alluvial plain with an average elevation of about 150 feet within the city limits, falling with a slight grade to the swampy lands adjacent to the Laguna de Santa Rosa, which runs close to the foot-hills on the west. The elevation at the Sebastopol railway station is but 68 feet above the sea.

Santa Rosa itself is on a low-grade alluvial fan which heads in a narrow gap in the foot-hills bordering the town. This gap connects with a basin of some 40 square miles, which empties its drainage on to the Santa Rosa fan, in a stream that formerly shifted its course over the slopes. Old channels are still to be found in places, altho they are usually filled by the grading for streets and buildings. A bridge formerly crossed the main channel on Tenth Street, near Mendocino. The approximate course of this channel is shown for a short distance on the accompanying map, No. 16. The present course of the creek was adopted but recently, according to the testimony of early settlers. The wells in town are shallow, and none were reported that had been sunk thru the alluvial deposits to bedrock. With these physiographic conditions, it will be seen that the alluvial fan upon which the town lies must have been filled nearly to the surface with ground water during the early springtime. The physiography of the vicinity is one of the factors to be considered in discussing the great destruction which was caused in Santa Rosa by the recent earthquake.

The shock of April 18 and the ensuing fire caused a loss of life of 61 identified dead, with at least a dozen "missing," and practically destroyed the business portion of Santa Rosa. (Plates 74, 75, 76, 77, 78, 79.) The equivalent of some 7 to 8 blocks was destroyed by the earthquake, and from 4 to 5 blocks by the fire. Conflicting reports are of course given as to the extent of earthquake damage in the burned district. The insurance companies have worked without any joint commission and no data were obtained from their agents. Judging from the unburned blocks adjacent, the buildings in the burned area were badly wrecked. One man told me that a book-store — Fourth Street, between Mendocino and B Streets — was not badly hurt by the quake and that he was in the lower floor and there was not much damage. In continuing his story, he stated that people were burned to death in the upper story of the same building because they were so caught in the debris that they could not be extricated.

The accompanying map (No. 16) shows the areas destroyed by the earthquake, and by the fire, as plotted in the office of the county surveyor, Mr. Newton Smyth. Other business men have since examined the map and agree to its substantial accuracy.

The residence portion of the town suffered to quite an extent. Chimneys were generally thrown down or so badly cracked as to necessitate their rebuilding. From twenty to twenty-five residences were thrown to the ground by the collapse of their underpinning, and badly wrecked. In cases which I personally inspected, houses close by, on ground apparently just the same, were but slightly damaged. The difference seemed to be in the character of the structural work. No uniform direction of fall was found in the wrecked residences. The reports of residences thrown "so many feet" were accounted for on investigation by the height of the underpinning which evidently determined the amount of motion. The accompanying photographs are illustrations. Thruout the town there were numberless minor injuries to plaster and fragile articles.

The physiographic results of the shock seem to be confined to some minor cracks in the vicinity of the cemetery with the possible addition of some small cracks near the creek bed adjacent to the tannery, as given in the detailed report below:

Mr. J. C. Parsons, city engineer, reports that he has found no changes in alinement since the shock. He thinks there are no changes in level, but has not yet made any accurate measurements of level. No disturbances of streets or sidewalks were found, such as are common in San Francisco.

Below are some detailed reports obtained from residents of Santa Rosa and vicinity. Few people on the street at the time of the shock were so situated as to make any valuable observations of the immediate and direct results of the earthquake.

Mr. J. W. Brown was living on Tupper Street, between Main and Brown Streets, about 5 blocks southeasterly from the court-house. His testimony is of value, as he was not distracted by any destruction of buildings in his immediate neighborhood. He was up at the time of the first shock and went outdoors to see if he could notice any waves in the ground, earthquake waves having been a subject of discussion with him in recent conversation. On going outside he heard a great noise from the west and saw the treetops waving. The noise and motion of trees approached him, and he took hold of a small tree near by for support. This tree was torn from his grasp. The ground seemed to be in waves "about 2 feet high and 15 feet long." Looking toward the court-house, he saw the dome swaying west and east, "maybe north of west," more or less in line with him, he added. The dome fell with about the third swing which he noticed.

Mr. Green Thompson was engaged in street sweeping at the time of the shock, and first heard a rumble like a wagon going over cobble-stones. He ran around the corner (Third



Santa Rosa.

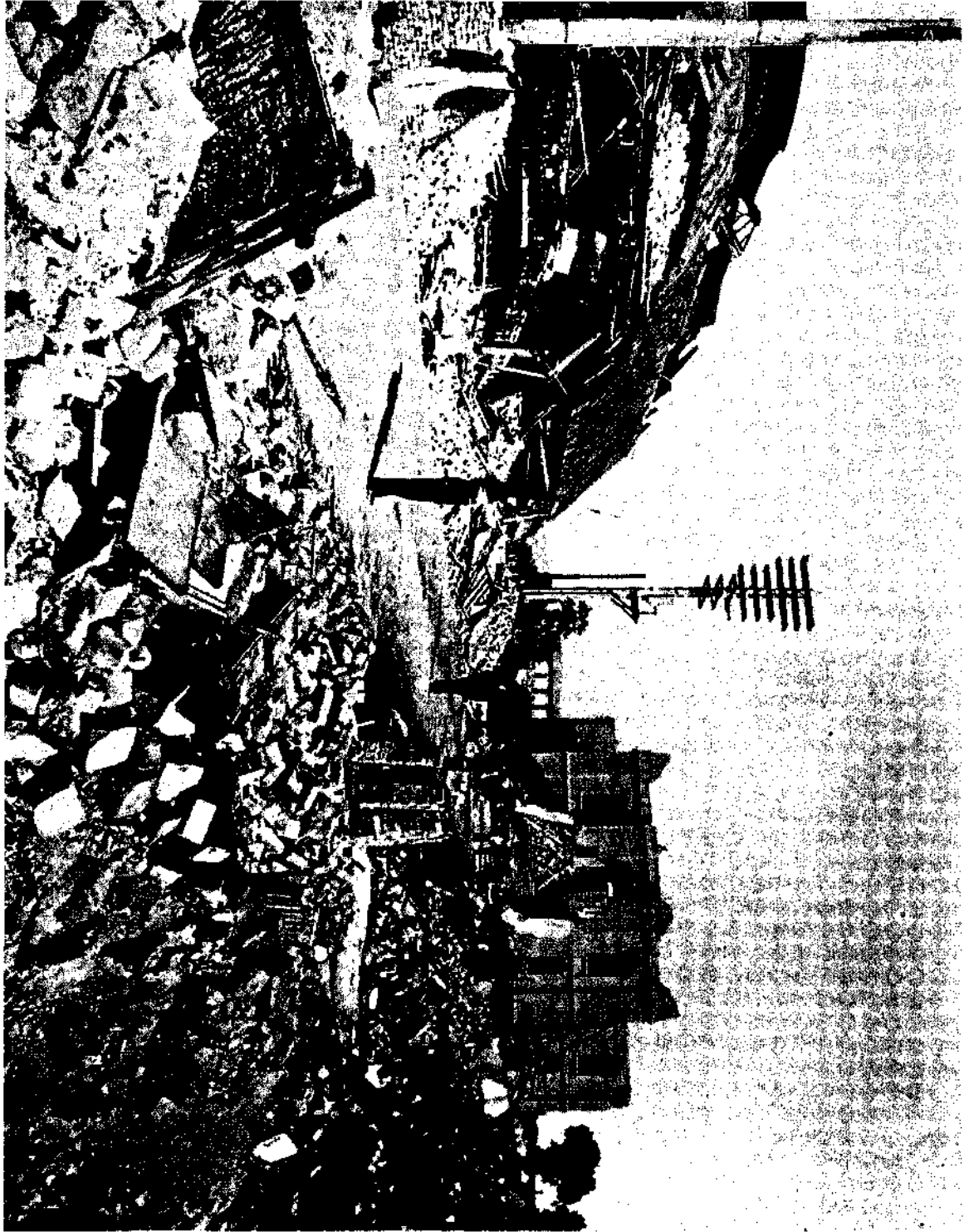



Santa Rosa.



and Main Streets) and stood in the street between the Grand Hotel and the court-house. He states that he saw the dome swinging southeast and northwest, tho later in describing the motion he added that it was swinging up and down Third Street, which runs south of west and north of east. "With the last swing the ground came up short and stopt," and then the building fell. "All the buildings fell at once; no one first." The dome of the court-house fell east. Down Fourth Street the dust was so great that he could see nothing. He is sure that he heard but one crash.

In general, inquiries as to direction of fall of buildings met no definite answer, or else the answer was very definite with no indication of good observational basis. Many told me that there was no direction of fall; that the buildings simply crumbled to the ground.

The Masonic Temple and the Theater, I was told, fell so directly downward "that the debris did not extend beyond the walls 10 feet in any direction." This was substantially my observation on passing thru the ruined district on May 1.

Mr. M. W. Keithby, the watchman at the tannery, F and Second Streets, says that the liquor in the vats was thrown straight up and then splashed out on all sides. The tanks tipt to the west. A 3-story frame shoe factory on the north side of the tannery grounds went completely down — being flattened with but little direction of fall. One of the foremen said that the fall was slightly to the north and that heavy machinery was found close to the north wall on the third floor.

A teamster working in the creek just south of the tannery says that he noticed cracks an inch wide and several rods long a few days after the shock. He "thinks the cracks were not there before."

Mr. Searey, a teacher in the High School, stated that the vibration was east and west. In describing the shock, he stated that in coming thru a doorway facing west, he was thrown against the north casing.

A rather large 1-story frame building on Eighth Street with a brick and stone foundation was shifted N. 3° W. On A Street, near Fifth, a cottage fell to the south. The house at Johnson and Mendocino Streets fell to the north, while of the two houses at Mendocino and College Streets, one fell southeast and the other north. On Fourth Street, near E, a residence fell to the east. On MacDonald Avenue, Mr. Weaver found two houses that fell to the north. The lack of harmony in the direction of fall, and the short time, prevented an investigation of the direction of fall of all the residences wrecked.

The main Santa Rosa Cemetery, just beyond the city limits on the northeast, was badly wrecked, but not to such a degree as the cemetery at Sebastopol. The direction of fall of monuments was carefully noted, but no indication of regularity resulted. Of square monuments of approximately equal size and conditions, 12 fell north, 10 south, 7 east, and 13 west. (See plate 80A, B.)

The most marked physiographic effects in the vicinity of Santa Rosa were found near this cemetery. Just north of the cemetery hill is a swampy depression. Part of this settled 2 or 3 feet with the formation of a crack along the side, extending for some 200 feet. The cemetery is on a low hill which the sexton reports as being sand, gravel, and clay, but which shows a rocky outcrop, on the eastern side, near the base. A crack an inch or more wide was found on the northern end of the hill near the swamp mentioned above. This crack could not be followed for more than 100 feet, altho the sexton reports that at first it extended 2 or 3 times that distance. A small water-pipe on the southern part of the hill, running north and south, was pulled apart. A pipe on the northern part of the hill, running east and west, is reported by Mr. Weaver as pulled apart about 4 inches. On the southwest of the cemetery hill, Mr. John Livsey reports that several fine cracks formed across the road running north and south, and that the dust was blown away near the edges of the tracks. He also reports that the trees along the road were swinging very definitely in line with the road, which here runs northwest. The only other physiographic effects found were at the County Hospital, a little more than a mile north of the cemetery. Here low ground at the foot of a small hill sank for some 2 feet and springs were formed. These springs were reported as still running the last of July. No connection could be found between the disturbances at the cemetery and the hospital. In the cemetery a large tank fell to the north. The tank was close to the water-pipe that was pulled apart on the north and south line.

At the Catholic Cemetery, some 2 miles southeast of Santa Rosa, only one monument fell out of some 20 of the class that were commonly overthrown at the main cemetery. Going farther southeast thru Bennett Valley, no physiographic effects were discovered and few chimneys were thrown down.

Not knowing of Mr. Butler's trip to the southward, I duplicated part of his work to the south of Santa Rosa, on the Petaluma road, with the same results as stated in his report.

Up the alluvial slope of Copeland Creek about 7 miles south of Santa Rosa, I found that chimneys were much more damaged than on the road northward from the creek to Santa Rosa, which usually follows the edge of the foot-hills.

Northeast of Santa Rosa, Mr. Butler reports that along the road to the Rincon District the damage was very slight, as it was also on the road running northwest from Santa Rosa toward Fulton. This road, it should be noted, keeps close to the foot-hills.

The most severe damage in the country around Santa Rosa was found to the westward in the vicinity of Sebastopol.

The great damage in Santa Rosa may be accounted for by the physiographic conditions and by the weakness of the buildings in many cases. The sand for mortar has usually been obtained from the creek and contains considerable loam. Some of the mortar seems to have been made with good sand and with cement. The old bank building, just west of the court-house, stands alone in that part of the wrecked area, a monument to good work. Usually throuth the wrecked area the mortar taken from the walls is easily crumbled to incoherent sand by pressure of the fingers.

(E. C. Jones.)—Very little damage was done to the gas mains in Santa Rosa as a result of the earthquake, but there were several explosions in the mains during the fire which followed. In several cases the cast-iron mains were blown apart; and when uncovered, the ends were found to be separated from 1 to 3 inches, according to character of ground.

At the generating plant the damage was principally to the brick building. The entire east wall fell outward, and the remaining walls were badly cracked. The columns of the gas-holder frames were thrown down, and the water-level in the tank was lowered about 6 feet. The holders were twisted out of position about 20°.

(C. T. Wright.)—There seem to have been two distinct motions in Santa Rosa, one from north to south, or more properly from north 30° west to south 30° east, the other roughly from west to east. The former motion seems to have been noticeable over a larger area and probably was the more violent. There is a belt along the Northwestern railroad tracks in which the west-east motion was specially noticeable, as shown by observations at the flour mill, the woolen mills, and the cannery. West of this belt, at the tannery on West Sixth Street, a distinct north-south, or northwest-southeast, motion was indicated, while east of this belt, in the region from Washington Street to A and B Streets, the northwest-southeast motion was specially evident and is the predominant motion. At Humboldt Street it becomes somewhat confused.

Most reports agree as to "choppy," rotary, or up-and-down movements following the pronounced horizontal movement, or between successive horizontal movements. This suggests interference of waves. The observed phenomena might be explained by the passage of a series of long, very rapid northwest-southeast waves of great intensity; and simultaneously or immediately following the beginning of this series, a second series of comparatively short west-east waves. Supposing the crest of the latter to have reached a line in the neighborhood of Washington, A, and B Streets, and the trough of this series to be near the Northwestern railroad tracks when a crest of the northwest-southeast series swept down, the two motions would tend to neutralize each other in the neighborhood of the railroad tracks and augment each other in the other district. It may be supposed that after the passing of this northwest-southeast crest and before the passage of another, the west-east waves were specially noticeable near the railroad tracks and did their destructive work there. If this theory be correct, another "trough" should be found between Mendocino Street and the Southern Pacific railroad station. The somewhat promiscuous directions of falling objects on Humboldt Street might indicate the approach to this region. To test the theory would require further observation.

(Marvin Robinson.)—Mr. Robinson of Santa Rosa states that he was just across Fourth Street and north of the court-house, and that at first the dome of the court-house seemed to be almost over him, and a few seconds later fell directly east. The brick buildings near him all fell east. He believes the street to have been vibrating in a vertical direction at the close.

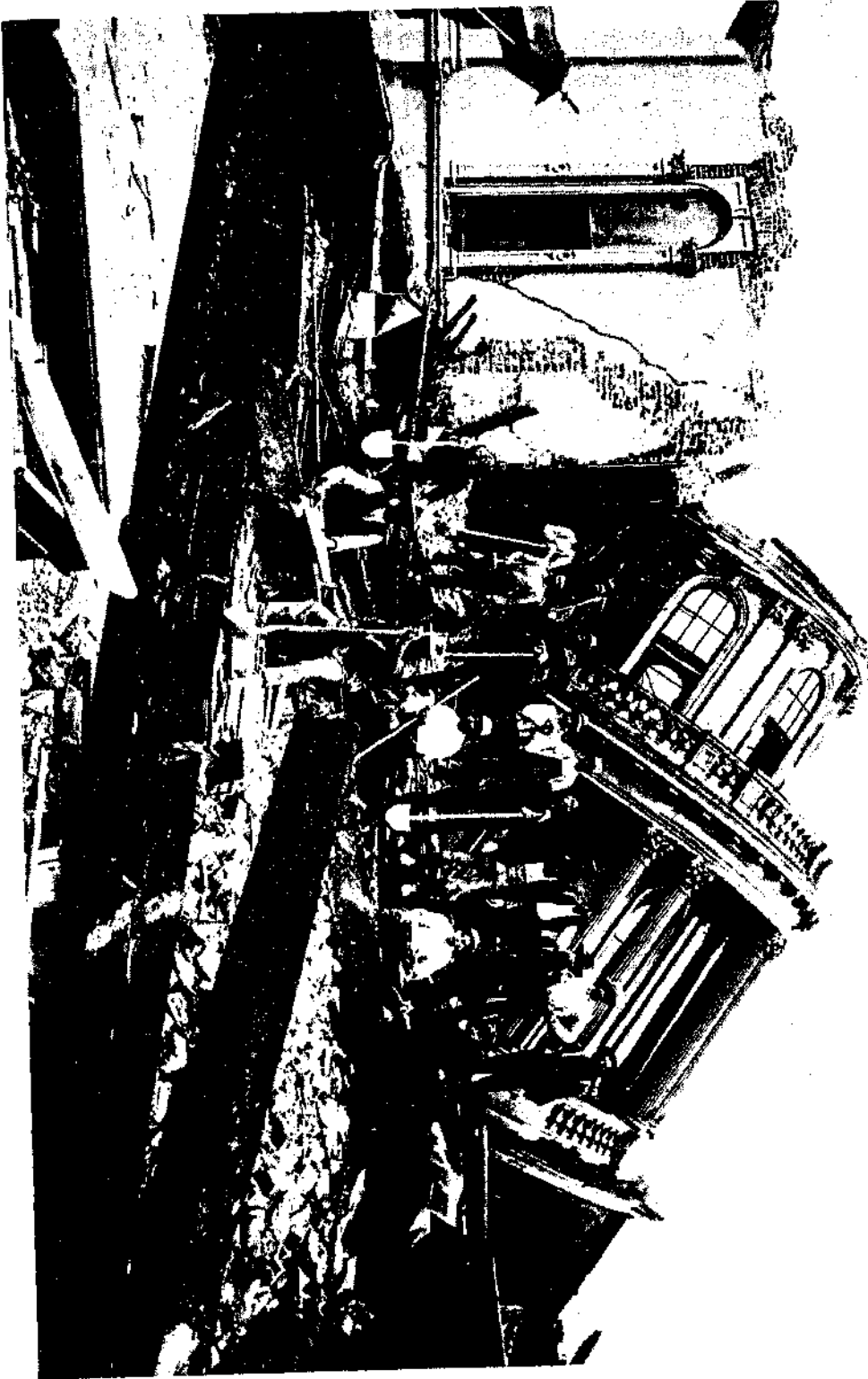

City Hall, Santa Rosa.



A. House moved 7 feet by collapse of underpinning, Santa Eosa. E. S. H.

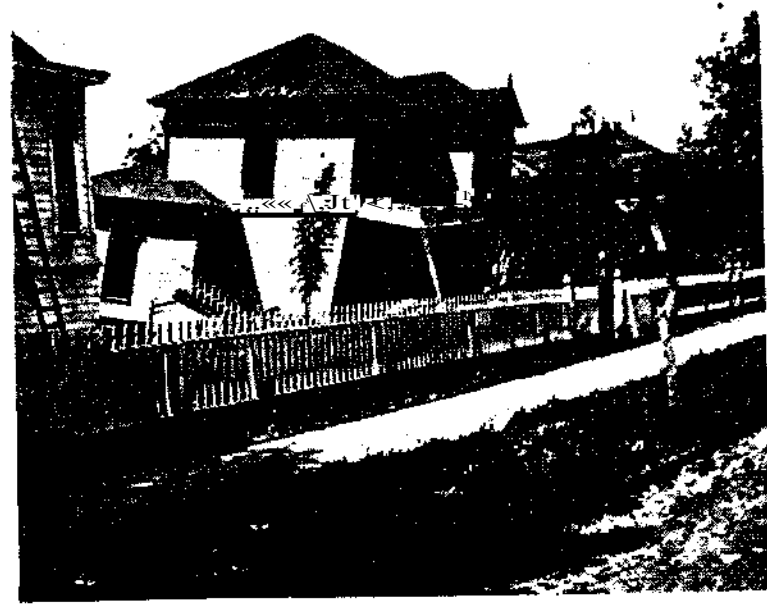

B» House lurching to north, Santa Eosa. B» S. H.



C. Wrecked dwelling, Santa Eosa, E. S. H.



D, Wreck of brick structure, Santa Eosa. E. S. H.



A. Cemetery, Santa Rosa. R. S. H.



B- Cemetery Santa Eosa. E. Si H.



C. Cemetery, Sebastopol. E. S. H.

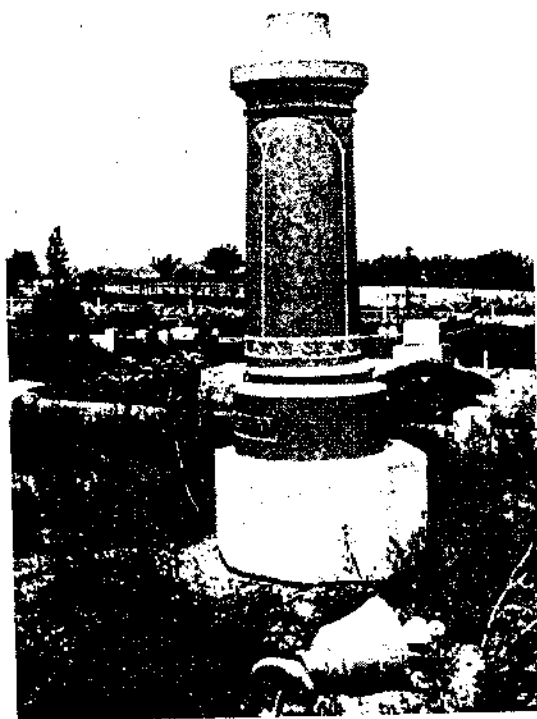

D. Cemetery, Sebastopol. E. S. H.



A. East side of main street, Sevastopol. R. S. H.

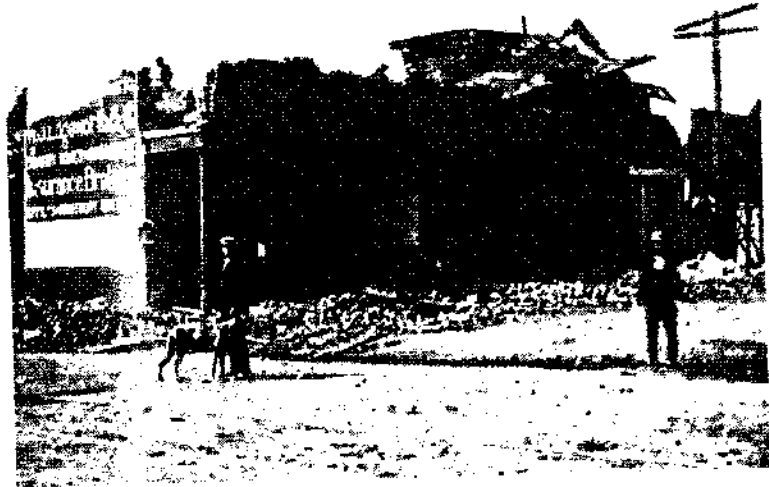

B. Wrecked buildings, Sevastopol. E. S. H.

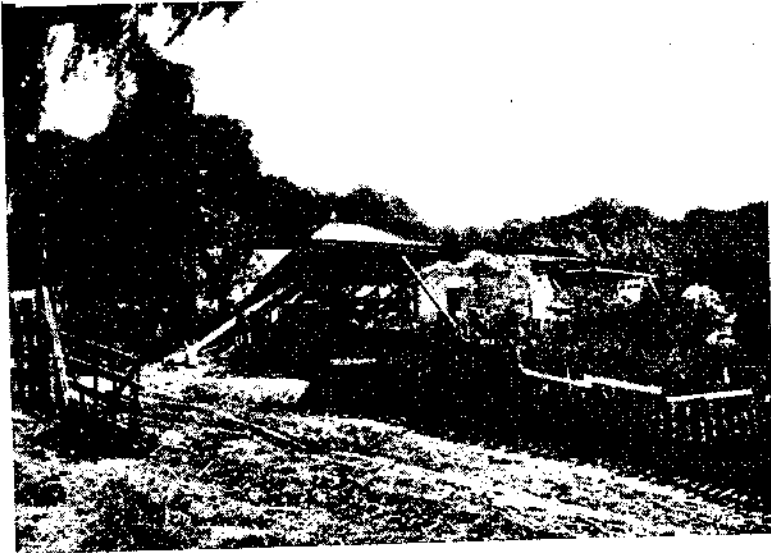

C. Stone house 1.5 miles southeast of Tomales, where two people were killed at time of earthquake. E. S. H.

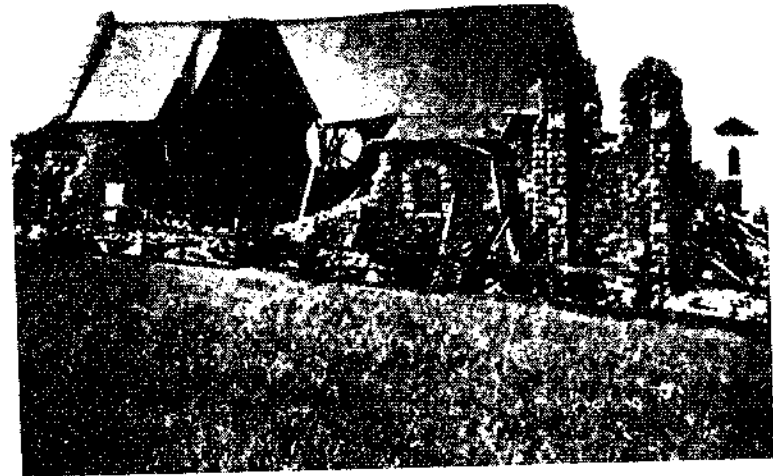

D. Wrecked church, Tomales. E. S. H.

(Charles Kobes.)—The vibrations in Santa Rosa were at first north and south, then east and west, and finally vertical. Mr. Kobes relates an instance in regard to the earthquake which occurred about 8 years ago. At that time sulfur fumes came up from under his house which almost drove his family from home. On April 16, two days before the shock, sulfur fumes came up equally as strong, and he told his family that he believed it meant another earthquake.

(Mr. Miller.)—The vibrations in Santa Rosa were at first north and south, then east and west, and finally vertical.

#### VICINITY OF SANTA ROSA.

(Drury Butler.)—Near the top of Taylor Hill, in a marshy place, there was a landslide, the earth having slid on a clayey bottom. In Bennett Valley the country is hilly, with some underlying basaltic formation, and very little damage was done. Beyond a distance of about 3 miles from Santa Rosa, only an occasional chimney was found that had been injured, and the effect was much less as higher ground was reached. Along the Sonoma road to the Rincon district school, beyond 2 miles from Santa Rosa, the damage was very slight. The road follows the creek, but here the hills come down to the creek. Over half the chimneys were uninjured, and none were completely thrown down except right along the creek. No bottles nor glasses were thrown from the bar-room shelves. Along the creek the shock was more severe than back from it. In the vicinity of the Sonoma County Hospital, the soil is very like the Santa Rosa soil and the shock was felt more. Glasses and bottles were thrown from the shelves in the bar-rooms, and at the hospital a marshy place along the creek slipt toward the creek and the flow of springs was greatly increased. The hospital also was pretty badly damaged. A trip was made out on the Petaluma road to the Copeland district school, then to Cotate, to the Durham district school, and back to Santa Rosa. The road followed the base of the hills for about 7 miles, then turned into the valley and was on the valley floor the remainder of the way. On the hillside very little damage was done, even to chimneys, while in the valley the chimneys were as a rule thrown down. I could hear of no cracks in the ground in the valley; and in only one place, about 2 miles from Santa Rosa, on the Petaluma road, could I hear of any increase or change in the flow of springs.

From these observations it was apparent that lines of equal intensity would follow the contour and geological lines of the country, and that the character of the soil on which a building stood determined the effect upon it, or the apparent intensity of the shock.

The general motion of the waves of the earthquake, as reported to me, was from north to south.

*Cotate* (C. L. Jeffrey). — At Cotate, 9 or 10 miles south of Santa Rosa, on the open level floor of the valley, the surface of the earth waved like water; objects were thrown southeast; hanging objects swung northeast and southwest. Only one maximum was observed. Trees swayed heavily, and there was a sound as if a strong wind were coming before the earthquake began.

*Wells East of Santa Rosa* (E. S. Larsen). •—At the city pumping station, 1.5 miles east of Santa Rosa, there are 4 wells dug 50 feet and connected with a tunnel 450 feet long. Within each well there is a bored well 8 inches in diameter and 108 feet deeper than the dug well. The water began to rise immediately after the shock, and has risen, May 8, 1906, 15 feet higher than it was before, altho the pumps have been run to their full capacity. The water tastes more of sulfur since the shock. The shock caused the pipes and boiler to leak.

At Peters' ranch the warm spring was little affected. Mr. Peters, the younger, says that for a day or so after the shock the water in the spring was lower, but that it is now normal.

*Sebastopol, Sonoma County.* Population 1,300. (R. S. Hoiway.) — Several buildings were completely wrecked. (Plate 81A, B.) The 2-story Knowles Hotel, a frame building, veneered with brick, went completely down, flattening the first story. The walls of the hotel fell out, so that the occupants of the rooms in the second story walked out on the ground level. The upper part of a brick stable was wrecked; also the upper part of the Walker Building, which is to the north in the same block. Three stores just south of the post-office were completely wrecked. North and south side walls both fell south, one falling out, the other into the building. The contents were badly scattered. A new frame house, a 2-story structure, was moved from 3 to 8 inches on the concrete foundation and the walls were cracked and wrenched.

The cemetery, about 0.7 mile west, is more severely wrecked than the Santa Rosa Cemetery. Nearly 90 per cent of the monuments of any size were thrown down. (See plate 80c, D.) The great majority of square monuments fell south. The heavy Talmage monument was moved southeast on its base. The sheet lead under the southeast corner shows one set of regular striae; the lead under the north corners is untouched. Cracks occur in the ground near the cemetery and near the Burbank ranch.

Mr. R. M. Hathaway, writing from a place 3 miles northwest of Sebastopol, sends the following information:

Many frame buildings in the vicinity were thrown from their foundations and some of them so damaged as to be uninhabitable. Chimneys were all shaken down, also brick furnaces. There are no brick buildings around here. The earthquake at my point of observation seemed to have an oscillatory motion, the vibrations traveling north and south. My house is a two and one-half story frame building on a low ridge of sandy hills running north and south, west of and parallel to the Santa Rosa Valley. All objects seemed to have a tendency to move toward the south. All furniture against the north walls was thrown down violently, some on the south wall going down also; while some remained upright as tho supported by the wall. Furniture against the east and west walls was moved toward the south.

The chimneys all fell to the south. Window casings on east and west walls were wrenched so as to break some glass. Injury to the frame houses in the vicinity, apart from damage due to falling chimneys, seemed to consist in throwing them from their foundations, and where a house consisted of several portions in the form of wings, these were separated. The foundations in some instances crushed, letting the buildings down to the ground. Well-constructed frame buildings, where the foundations were low, did not collapse. At the Sebastopol Cemetery, about a mile west of Sebastopol, the monuments were nearly all overthrown, falling in all directions, altho I estimate that fully half of them, if not more, fell to the south. I did not notice any change in water level, the change if any being small. There were some fissures made in the ground near here.

President David Starr Jordan contributes the following note relative to the effects of the earthquake at Sebastopol:

The violence of the recent earthquake was very great at Santa Rosa; much less at Petaluma, which is equally near the crack and on still flatter ground; and still less at San Rafael farther south but the same distance from the earthquake Rift. At Sebastopol, 6 miles west of Santa Rosa, the violence was relatively still greater, the village being tremendously shaken up. At Burbank's farm, 0.5 mile west of Sebastopol, I noted these things: In the lot adjoining, to the south, the soil being clayey, there is a large crack running northwest and southeast, or nearly so, and, according to Burbank, 0.25 mile long. It runs thru the fields and weeds, and was very distinct on August 6. The end of this crack comes up against the sandy hill occupied by Mr. Burbank's orchard. The crack does not show itself in the hill, but on the east side of the line of the crack the rows of trees and plants were shifted toward the south — or, if you prefer it, those on the west side toward the north — 2 or 3 feet. A well of Mr. Burbank's, sunk in the sandy ground, is bodily shifted, without being injured, along with the rows of plants between which it is placed. No crack appears at the surface in Burbank's ground, but on the other side of the hills, to the north of it, I was told the crack reappears.



According to the record of Matthes and Holway, similar cracks appear in the same line 4 miles and 9 miles north of Petaluma, and there seem to be other breaks on the way toward Point Delgada. It seems certain that this first crack is an earthquake rift, and that the disturbances at Santa Rosa and Sebastopol are due to this and not to the main Rift which lies parallel to it to the west.

Mr. G. K. Gilbert also visited the Burbank farm at Sebastopol, and contributes the following note referring in part to the cracks discust by President Jordan:

Mr. Luther Burbank gave me an account of personal experiences and of various phenomena at Santa Rosa, and I record such items as are supplementary to Professor Holway's report. Mr. Burbank was awake at the time. He immediately got out of bed, but found he could not stand, and settled back against the bed, holding on to the window casing and bedpost. The initial impulse was from the west, and during the first portion of the earthquake the motion was oscillatory, east and west. Then it became oscillatory north and south, and at the close there was a complex motion which he compared with that of a vessel in a choppy sea. From the window he saw trees waving, and after the tremor had ceased he seemed to see a continued disturbance in the foot-hills at the east, as tho the tremor was retreating in that direction. He said that practically every one in Santa Rosa who was on foot at the time was thrown to the ground, but that men on bicycles were not upset. During more than 30 years' residence in Santa Rosa he had felt about 130 earthquakes. None were comparable in violence with the recent one, tho several had broken chimneys. A number of earthquakes which were felt generally in Santa Rosa had not been felt at all in Sebastopol, and he thought that Santa Rosa was peculiarly subject to shocks.

A shock was felt in Santa Rosa on April 17, 1906.

Mr. Lawrence, foreman on Mr. Burbank's farm at Sebastopol, stated that men standing or walking at the time of the shock were thrown from their feet, as were cows and horses. The small house on the Burbank place was moved from its foundations a few inches downhill, and Mr. Lawrence mentioned a number of houses which had moved various distances, the direction in every case being downhill. On the Burbank farm a small landslide occurred, a layer of moist soil only a few feet in thickness moving down the slope, introducing bends in various lines of cultivated plants. I saw another feature of this sort on an adjacent farm, and was told of others which I did not visit.

In a general note on the intensity of the earthquake, appended to detailed observations which have been incorporated in the foregoing account of the distribution of intensity, Mr. G. K. Gilbert says:

In general the violence seems to have been less in Petaluma than in Sebastopol, Santa Rosa, or Maacama, notwithstanding the fact that it is nearer the main fault. As compared with Sebastopol and Santa Rosa, however, Petaluma seems to be on relatively firm ground, excepting a small district bordering the marshes. In a general way, I think the relative violence in the three towns corresponds to the character of their foundations, but considering the district as a whole, in relation to districts nearer the main fault, it is clear that the intensity was exceptionally high.

*Altniria, Sonoma County* (R. S. Holway).—About 5 miles north of Santa Rosa, at Altruria, cracks are said to have opened in the road, and springs to have flowed for a short time. There was no indication of either last May.

*Mark West Springs* (R. S. Holway).—The concrete walls of several springs were cracked and damaged. Chimneys fell on the house. The springs are reported as flowing much more freely, and the temperature of two of them is said to be very much higher than before the earthquake. They are now quite warm to the hand, and it is said that they were formerly cold. I could get no reliable information as to temperatures, as no records were kept. The increased flow is independently indicated by circumstantial evidence.

*Windsor*. Population 130. (R. S. Holway.)—Here 2 or 3 brick buildings were badly wrecked, and the water-tank at the railway station was overthrown. The cemetery

about 1.5 miles south of Windsor is on low, rolling hills. Only 4 monuments out of 35 to 40 of the class wrecked at Sebastopol and Santa Rosa were thrown down.

*Guerneville.* Population 500. (R. S. Holway.) — In this town all brick buildings were badly wrecked. Chimneys generally fell. The Commercial Hotel, a frame building, was twisted slightly, contraclockwise. Under the house of Mr. Turner, which is built on piles, the piles on the east side were thrown 8 inches east and those on the west side 4 inches north. Mr. Turner reports the shock as clearly from north to south. His workcases were thrown from north to south. The cemetery, which is on a terrace 190 feet by aneroid above the flood plain on which the town stands, was very slightly affected. One monument is reported to have fallen. Three or four show slight shifting.

#### SANTA ROSA VALLEY TO SAN FRANCISCO BAY.

*Petaluma.* Population 3,900. (R. S. Holway.) — The inspector of chimneys reported that the great majority of chimneys fell. (See fig. 64, page 341.) In east Petaluma, on the lowland, all but 4 fell. Three brick stores had the entire front thrown out, and 10 or more had tops of fire-walls thrown down. The stone hay-barn of McNear was wrecked; also a corner of the stone warehouse. The 2-story brick silk factory had every corner wrecked. The central tower and the large brick chimney were thrown down. The ice plant near the station had the high brick stack thrown, wrecking part of the building. The Golden Eagle, a 4-story brick flour mill, was not damaged; but the 1-story addition and a 1-story stone warehouse had portions of their walls fall. There are no authenticated reports of cracks in Petaluma nor in the low tidal lands immediately adjoining. Vague reports to this effect were not verified. (See plate 73A, C.)

*Lakeville, Sonoma County* (C. A. Bodwell).—This place is about 6 miles southeast of Petaluma, on a hill slope near the tidal marsh of Petaluma Creek. Chimneys were overthrown, plastering badly cracked, and dishes broken. Chimneys and objects were thrown to the southeast. There were 2 maxima in the shock, of which the second was the stronger. The movement was from southeast to northwest.

*Petaluma northward up Sonoma Mountain* (R. S. Holway). — Northeast about 2 miles across the low land, chimneys were thrown down and furniture was moved. No cracks were reported in the ground. Thence northward to an elevation of over 1,800 feet, nearly all the brick chimneys were down. Houses are usually small 1-story frame buildings. Articles were reported thrown from the shelves and furniture moved. "House shaken so severely I could not walk across the floor," was a common statement. No landslides were reported, altho quite a number occurred in this region during the winter.

*Petaluma to Sebastopol* (R. S. Holway). —A drive along this road, which keeps near to the western line of Santa Rosa Valley, showed an increasing intensity of shock from Petaluma toward the northwest. Chimneys were quite generally down along the entire line. At Jur's ranch, about 2.5 miles northwest, 3 cracks with a very slight dropping of small blocks between them, are reported. A temporary flow of water was reported from a crack by the road. Small cracks were reported on the road about 4 miles from Petaluma. Near Stony Point school-house, about 9 miles out, 19 cracks across the road were reported by the teacher. At Nason's ranch there is a landslide of the bank of the lagoon 100 yards or more in length. Four miles from Sebastopol is another landslide at Davis' ranch, where a house was thrown from its underpinning. Cracks were reported at Hansen's and several places. There is a distinct increase in cracks and landslides in the approach to Sebastopol.

*San Rafael, Marin County.* Population 3,900. (R. S. Holway.) — "Half the chimneys down" was a frequent report. Most of them were rebuilt at the time of my visit. "A. W. Foster's place, on the hills to the north, had 100 chimneys and only one fell." A brick

building one block north of the station had the top of the end wall thrown down. A 3-story brick hotel was very slightly cracked. On May 1 the town showed no sign of earthquake to the casual observer. A crack one block long, north and south, in low land near the station is reported. At the Hotel San Rafael 2 chimneys fell on the roof and porch. At the cemetery, 2 miles north of San Rafael, only 3 monuments and some 8 crosses fell. Mr. Weaver reports that on 12 houses near the station and the Hotel San Rafael chimneys fell east. My own inquiries up town were generally answered by "all directions," so far as chimneys were concerned.

San Anselmo Theological Seminary is a etone building on a rocky knoll, not tied by rods. The tower of the library fell, part of it crashing thru the roof to the first floor. At the dormitory the coping on top of the walls and the chimneys have fallen on all sides of the building.

Mr. Frank M. Watson reports the following effects of the earthquake in San Rafael:

In the drug store of Mr. Inman, Fourth and C Streets, hundreds of bottles were thrown from shelves running east and west, and bottles on shelves running north and south were thrown parallel with the shelving.

At St. Paul's Church, Fourth and E Streets, the chimney moved 0.375 inch bodily to the south, and bricks were crushed out on the north side. A chimney to the west of this was overthrown. The Grammar School, west of this church, had 2 chimneys down. The High School to the south suffered no damage, but bottles moved on a shelf mostly to the west.

At the house, 17 Fourth Street, on level land, the occupants felt 2 shocks with a very short interval between, the first being longer and lighter than the second. The general direction of movement was thought to be east and west. The chimney fell east. The clock stopt. The shock was lighter on the rising ground to the south, as inferred from less damage to chimneys in that direction.

At the house of Mr. W. Robertson, 20 Fourth Street, on level land, an up-and-down motion was experienced. The middle portion of the shock was the heaviest, and it was then that a marble mantel fell east.

At the building occupied by Mr. George D. Shearer, 306-310 Fourth Street, on level land near the depot, there is a crack running north and south; 4 chimneys fell west and 2 east on a flat roof. The north end of a wall of the building fell out down to the level of the second-story floor. The coping on north and south walls fell off, and plaster was badly cracked on inside partitions. In the adjoining house, Mr. Joseph La Franchi was awake, his bed lying east and west. The shock was north and south. The chimney from the next building crashed down thru his house.

At the office of the Western Union Telegraph Co., 608 Fourth Street, a clock facing the east stopt at 5<sup>h</sup> 13<sup>m</sup> A. M.

At the jewelry store of Mr. J. D. Bennett, 709 Fourth Street, on level ground, 2 large accurate pendulum clocks hung 10 feet apart, one on an east wall and the other on a west wall. One stopt at 5<sup>h</sup> 12<sup>m</sup> 35<sup>s</sup>, the other at 5<sup>h</sup> 13<sup>m</sup>. These clocks do not vary 3 seconds in 24 hours, and were right at noon of the previous day.

At the Grand Central Hotel, 720 Fourth Street, on level land, an up-and-down motion was felt, then an oscillation from east to west. The building, built of brick in 1860, is 3 stories high. It shows a crack 0.5 inch wide in the east wall, extending from the roof to the second floor, and there were also cracks in the south wall over the windows. Some plaster fell and one chimney was broken.

At the house of Mr. George L. Richardson, county surveyor, on Harcourt Street, on level land, 2 shocks were experienced; the first apparently heavier than the second, both being of about the same duration. The oscillation was from east to west. No damage to residence. At his office in the court-house, the marble back of a washstand was thrown west, and plaster was cracked on east wall.

At the house of Mr. L. Armstrong, 206 Ross Street, on a hillside 50 feet above sea-level, milk and cream slopt from pans a little north of northwest. There was no damage to buildings or chimneys in the neighborhood. A slackening in violence was noticed about the middle of the shock.

At the San Francisco and North Pacific railroad depot, on level land 7 feet above sea-level, the night operator, Mr. Vernon Grisham, reports first an oscillation, then an up-and-down movement. Buildings shook for 2 minutes by the watch in an east and west direction.

The clock stopt at 5<sup>h</sup> 12<sup>m</sup>-30. It does not vary 2 seconds in 24 hours, and is set daily by telegraph. A crack was formed in the ground 100 feet long, running north and south. The greatest damage was half a block north of the depot. The depot itself suffered no injury.

At an unoccupied house on D Street, opposite Ross Street, a chimney moved 1 inch west and twisted clockwise about 5°. A second chimney moved bodily westward 0.75 inch, and was similarly rotated. All the chimneys in this vicinity were down.

At the grocery store of E. Kolepka, First and E Streets, a 2-story brick building, all 4 chimneys were cracked but left standing. Goods in the store were thrown from shelves running north and south, and to a less degree from shelves running east and west. Some plaster fell from the ceiling, and all chimneys in the neighborhood were damaged or thrown.

Mr. W. Robertson, city inspector of chimneys, reports that there are 1,200 chimneys down and many more damaged. Probably 100 were twisted, the amount and direction of the twist being quite variable. Most of the chimneys, however, fell northeasterly. On the hills the shock was lighter.

At Scheutzen Park, 1.5 miles east-southeast of San Rafael, on land 7 feet above sea-level, 2 shocks were felt: the first light and long, the second hard and short, the direction of movement being east of north. There was no serious damage to buildings or chimneys, but water-pipes were broken, and there were many small fissures in the neighboring ground, running north and south.

At the Catholic Cemetery, 2 miles north of San Rafael, on rising ground, an up-and-down movement was experienced. A clock in the house of the guardian tipped over, but no damage was occasioned to buildings. There were 3 monuments and a few light crosses overthrown in the cemetery. The chimney of the brick yard, a mile to the east, remained intact.

At the residence of Mr. C. Day, near the San Anselmo Seminary, the east chimney was twisted clockwise 10°; and the chimney on the church next door was affected in the same way. Things on the walls fell east. One chimney fell west.

*Novato* (F. M. Watson). — Town is situated on sloping ground. Mr. A. Scott states that 2 shocks were felt, the first east and west and light, the second north and south and heavier. In the grocery store canned goods were tipped south on shelves running north and south. Chimneys as a rule were not damaged, but the top of Mr. Scott's chimney moved 1 inch to the southwest. Two clocks were stopt.

*Samalito* (F. M. Watson). — Nearly all chimneys were thrown, most of them falling about northwest. Mr. Landon's 1-story house, on a hill about 125 feet above sea-level on hard rock, was moved slightly to the west on its foundations. On this house 2 chimneys fell to the west. The earth was cracked on the low ground near the station, the fissures running north and south. The railroad clock stopt at 5<sup>h</sup> 13<sup>m</sup>.

*ML Tamalpais* (W. W. Thomas, of the Weather Bureau Observatory). — The observatory is in a slight depression between the east and middle peaks of the mountain. A number of rounded peaks form a prominent ridge about 3 miles in length, extending nearly east and west, and having an average elevation of about 2,500 feet. Rocks are exposed everywhere at the surface. No chimneys nor other tall structures were overthrown, but ornaments and small objects were thrown from shelves that ran north and south, or were more or less displaced in a direction somewhat south of west or north of east from their original positions. No objects fell from shelves that ran east and west, and no object moved north or south of its usual place was observed. An anemometer fell from the instrument stand to the floor, where it lay in a direction about west-southwest of its place on the stand. The instrument is so balanced that it takes no greater force to overturn it in one direction than in another. There were 2 maxima in the shock, and the first was the stronger. The direction of movement was about west-southwest and east-northeast. A vertical movement is inferred from the fact that all four of the direction arms on the triple register recorded at one time. This would indicate that the instrument received a sudden jar or series of jars in a vertical direction, for no electrical contact nor any amount of lateral shaking can cause all four of these arms to record at the same time. Some plaster fell, and a part of a loosely constructed stone wall was thrown down.

*Angel Island Light Station* (Mrs. J. E. Nichols). — The shock resembled the jolting of a railway train which, running at full speed, had left the tracks and was bumping over the ties. It was accompanied from the beginning by a loud noise which gradually decreased as the jolting motion ceased. Water standing in a pail was thrown out 6 feet from northeast to southwest. The clock was stopt. The bay was calm. A cement pavement was cracked to pieces. The station is on solid rock.

*Yerba Buena Island Naval Training Station* (Capt. A. T. Marix). — A heavy vibratory shock was felt.

*Alcatraz Island*. — A heavy shock was felt in which there were 3 maxima, the middle being the strongest. Objects were overturned in every direction.

*Southeast Farallon Island* (James A. Boyle, assistant observer of the U. S. Weather Bureau). — The ground is composed almost entirely of solid rock. The Weather Bureau building is on a narrow neck, 15 feet above sea-level, between 2 peaks about 300 feet high. Objects in this building were thrown east. A stone weighing about 100 pounds slid 6 inches west by south, and was turned slightly counterclockwise. There was no rotary nor vertical motion felt. There were 2 maxima, of which the first was the stronger, and the motion was east and west in both cases. The only damage done was the opening of a crack across the entire front of the fireplace. Two rock slides, of about 100 tons each, occurred on the west end of the island. At 10<sup>h</sup> 06<sup>m</sup> A. M., April 18, two distinct vibrations were felt. They were also felt by Mr. Legler, of the Weather Bureau Station at Point Reyes Light-house, with whom Mr. Boyle was talking over the telephone at the time, 3 seconds before they were felt on the island.

#### SONOMA VALLEY.

In the Sonoma Valley Mr. E. S. Larsen made the following observations:

*Melita*. — Chimneys are all down and plaster somewhat broken. Shock somewhat less than at Santa Rosa.

Between Melita and Kenwood conditions were about the same. Nearly all chimneys were thrown down or twisted.

*Kenwood*. — Most of the chimneys were down. The brick hotel was not much injured, but a few poorly constructed 1-story stone buildings were somewhat damaged.

*Glen Ellen*. — Chimneys were nearly all down. Popp's poorly constructed 2-story stone building was damaged so that the upper story had to be torn down. One wall of a brick building whose braces had been removed to make room for a stairway was much cracked. The other walls were little damaged. A clock with a half-second pendulum, facing south, stopt at 5<sup>h</sup> 13<sup>m</sup>. A fireman and an engineer on the San Francisco and Northwestern Railroad say that the shock started at exactly 5<sup>h</sup> 13<sup>m</sup>.

*Eldridge, State Home*. — All chimneys were thrown down and the upper story of each of the 3-story brick buildings was so damaged that it had to be removed. In a few cases there were cracks in the lower stories. One large electric clock with a second pendulum, facing northeast, stopt. Another clock with a half-second pendulum, facing southwest, did not stop, but its pendulum was turned about 20° clockwise.

*Aqua Caliente*. — Most of the chimneys were thrown down and the plaster was cracked. There was little damage to the brick and adobe houses.

*Boyes Hot Springs*. — An artesian well 97 feet deep now yields a larger stream.

*El Verano*. — Nearly all chimneys were down. A clock with a half-second pendulum and facing east stopt at 5<sup>h</sup> 15<sup>m</sup>.

*Sonoma*. Population 650. — Chimneys were nearly all down. Some of the brick and adobe buildings were damaged, but the shock was much less severe than at Santa Rosa. At the Hillside Cemetery, 0.125 mile east of the railroad depot, out of about 18 tombstones over 4 feet high and having the usual square or round section, 13 were

turned on their bases from a few degrees to 20° counterclockwise; 2 were down and 2 had the top ornaments thrown off. At the Catholic Cemetery, out of 6 tombstones of the above type 1 stone was turned clockwise and 1 counterclockwise. This cemetery is in the valley. The Valley Cemetery has 2 tombstones out of 6, of the above type, turned counterclockwise. The Sonoma Valley High School had 3 chimneys out of 6 turned counterclockwise; the other 3 fell. I found chimneys on 3 other houses turned counterclockwise, and 1 chimney turned clockwise. Two miles south of Sonoma, at Mrs. William Clemens', all 3 chimneys were turned counterclockwise. Mr. T. A. Lewis, physics teacher at the High School, described the shock as being at first a temblor, vibrating northeast and southwest, then a short calm, and finally a longer and harder twisting shake. Dr. Grey, of the State Home at Eldridge, and several others, gave a similar description.

*Shellville.* — About three-fourths of the chimneys were thrown, or twisted.

#### NAPA VALLEY TO THE SACRAMENTO VALLEY.

*Napa Valley* (C. E. Weaver). — At Calistoga, population 700, a large number of chimneys fell and 2 brick buildings were thrown down. Clock stopt. A few local slides on the south side of Mount St. Helena were confined to the alluvium. At the town of St. Helena, population 1,600, a stone building of the California Winery Association was slightly damaged, and 8 brick chimneys in the town were overthrown. At the Veterans' Home, at Yountville, the buildings constructed of brick and stone had two corners thrown down and the walls cracked. At Napa many brick buildings were cracked, and walls thrown down. Chimneys were generally overthrown. No damage was sustained by the concrete buildings, nor by the machinery contained in them, at the cement works at Napa Junction.

*Calistoga, Napa County* (Dan Patten). — Nothing was thrown down in the house. In the milk-house cream was thrown from full pans on the northeast side. A large water trough near the house had the water thrown out on the northeast side. Some large rock was thrown down from cliffs up on the mountain (Mount St. Helena) at an elevation of 4,000 feet on the northeast side. Mr. Patten was in front of the house, the east side, and heard a rushing noise. He had time to look up the road to the south, and then turn and look north, expecting to see some fast driving team, before the shock came. He felt first a tremor, and then 2 heavy thumps a few seconds apart; then tremors gradually decreasing until probably 0.75 minute had elapsed.

*St. Helena, Napa County* (F. Blachdowski). — At the Sanitarium near St. Helena, which is on a hillside with rock near the surface, objects were thrown mostly toward the east. Some chimneys were turned counterclockwise, and a twisting motion was felt. There were 2 maxima in the shock, the second being the stronger.

*Rutherford, Napa County.* — Mr. Joseph Mora was starting out on his bicycle when he heard a loud noise like that of a country wagon; he stopt and was then shaken by the earth moving violently; the trees swayed wildly. The sound and the shock came from the southwest. All the wine-cellars and structures that were not well built were partially thrown down. Chimneys came down from all buildings. Niebaum's wine building showed no cracks.

*The Veteran\*' Home* (A. Brown). — The Home is on sloping bench land in the foothills on the west side of Napa Valley. The chimneys on some of the buildings were twisted around, and some tumbled over. Mr. Brown felt his bed rocking north and south for about 15 seconds. A clock stopt. Some plaster fell at the new hospital. Only one maximum was observed in the shock.

Mr. J. M. Clark, of the Veterans' Home, who maintains a seismograph of his own construction at that institution, reports that the hardest portion of the shock came, as near as he could judge, about 20 seconds after the beginning. There was a rapid increase in intensity up to that time; then came the gyratory, upward, jerky motion, which was

very severe. This continued for about 10 seconds, and then came a swaying motion, that seemed at right angles to the first.

A chimney stack, of brick, 120 feet high, belonging to the power-house on the Home grounds, was shattered. Its rectangular faces fronted to the northeast, southeast, southwest, and northwest, respectively. In two places, one about 40 feet and the other about 60 feet from the ground, the upper portion of the stack was shifted, as if the rotation were from north to west to south to east, it being understood that the motion of the earth was in an inverse direction to that of the twisted distortion of the chimney. The westerly corner hardly moved while the easterly corner was shifted several inches. The lower fracture had a displacement of about 2 inches at the easterly corner, and the upper fracture had a similar displacement. In the dispensary of the Home, the first portion of the shock threw the bottles from the shelves upon northwest and southeast walls. The latter portion of the shock precipitated the bottles from the other walls. This was proven by finding articles from the northeast and southwest shelves lying on top of those from northwest and southeast shelves.

*Napa State Hospital.* — The effects of the earthquake are thus described in the Climatological Report of the U. S. Weather Bureau for April, 1906, by Mr. W. H. Martin:

At 5<sup>h</sup> 14<sup>m</sup> A. M. on the morning of April 18, 1906, a severe earthquake commenced, and lasted about 80 or 90 seconds. The apparent motion at the beginning was from the west by south to the east by north, a rolling motion for about 15 to 20 seconds, then a light interval for a few seconds, then a renewed force of a twisting nature, intensity IX. The ground, to the eye, seemed to be quivering; the hills seemed to have a rocking motion, the trees seemed to be shaken by the hands of a giant; everything looked to be in motion; the air was hazy and still. Many brick and stone walls were thrown to the ground and others damaged to such an extent that they will have to be taken down. Nearly all chimneys were thrown down, and of those standing some are turned a quarter way round. Milk in pans was thrown out in an easterly and westerly direction. The estimated damage to the city of Napa is about \$150,000. The damage to this institution was very light, except that the main tower will have to come down.

*Napa (E. C. Jones).* — The damage to street gas mains at Napa was very slight, only two leaks developing. The gas station was badly shaken up; about 10 feet of the end wall of the brick building was thrown down, falling on top of the boiler and breaking off the steam pipes. The gas-holders were badly shaken. Water was displaced from the tanks, but only one guide wheel was shaken out of place.

*Wooden Valley, Napa County (H. W. Chapman).* — On level alluvial ground near the base of the surrounding hills, no objects were overthrown. There were 2 maxima in the shock, of which the first was the strongest, the movement being north and south.

*Pope Valley, Napa County.* — The top of one very old chimney was thrown over, falling to the south. Another was cracked, and 4 or 5 bricks from the top of another fell down into the fireplace.

Mr. H. P. Gordon reports that he was in Pope Valley at the time of the earthquake, and that the shock awoke him. It seemed to be a tremor at first, then an oscillatory motion east and west. It seemed to him as if his bed were a gold pan, and he were being panned out. His house stands on rock.

*Berryessa Valley, Napa County.* — The shock is reported to have been quite heavy on the level land of the valley-bottom.

*Vattejo, Solano County.* Population 8,000. (W. D. Pennycook.) — The shock was quite as hard as that of 1898, when the brick structures at Mare Island navy-yard were very much damaged, some of them having to be taken down. The vibrations in that earthquake were lateral, nearly north and south. The vibrations of the earthquake of April 18, 1906, while equally severe, were different in character. In Mr. Pennycook's house are 2 mantels facing north and south, and a large china closet. In the earthquake of 1898 every article on both mantels was thrown to the floor, and in the china closet the crockery

was thrown from the shelves. On April 18, 1906, nothing was thrown from the mantels, but a clock, which in 1898 had been thrown to the floor, was turned around about 20°.

The postmaster of Vallejo reports that the city is on a hillside adjoining the Mare Island strait. The surface is rolling and has very little level land except such as has been cut down, which is entirely of clay and soft rock (shale). Sandstones and shales are the underlying rocks, and these come close to the surface except along parts of the edge of the strait. There was a noticeable decrease in the violence of the shock toward the middle, then an increase in severity, the latter part being the stronger. The movement was north and south. Objects hanging on gas fixtures by ribbons wound themselves up on the same. The Post-office clock stopt. The floors appeared to rise and fall. All the damage done was to chimneys; not a brick wall showed any injury. The greatest damage was done in the lower levels, the hills suffering very little.

(T. J. J. See.)—Vallejo is built on hard ground and did not suffer very severely from the earthquake. The best estimates obtainable showed that about one-tenth of the chimneys were knocked down, or so broken loose that they had to be taken down. The shock was not so severe as that of 1898, which was much more local in character. No house in Vallejo fell, and chimneys were about the only fixed objects thrown down. Various objects in the houses were overturned, such as bookcases, bric-à-brac, and dishes on shelves; and the plastering was somewhat cracked. In general, however, the injury was not great.

*Mare Island* (T. J. J. See). — The earthquake was much less severe than that of 1898, which wrecked many of the Government buildings in the navy-yard. None of the Government buildings was wrecked this time, nor was the damage at all serious except in the case of two or three new buildings recently erected on the "made" land near the water-front. Here the ground was thrown into violent undulations, and the buildings were so twisted that about \$2,000 worth of repairs had to be made. On this soft ground the brick walls were cracked, but as the buildings have steel girders, no part of them fell except one or two top-heavy cornices. But the swaying of the brick walls tied together with steel frames caused the walls to be cracked and scaled off near the steel supports. In the case of the older buildings resting on hard ground, no cracks were formed, nor any injury reported. No chimney on Mare Island was thrown down, and only one or two were broken loose at the roof so that they had to be taken down. The amplitude of the vibrations in the soft ground at Mare Island was found by measurement to be 2 or 3 inches. This was determined from the displacement of the loose dirt around the piles supporting the steel frames of the buildings on the "made" land. On the whole, the intensity was about the same at Mare Island and Vallejo.

Prof. T. J. J. See contributes the following note on the swaying of a smoke-stack at the navy-yard on Mare Island:

" This smoke-stack is made of steel, bolted together in sections and lined with fire-brick 150 feet high and 6 feet across at the top. Three separate witnesses, standing at nearly equal angles about the base, and something like 100 yards away, observed the tower writhing and twisting during the earthquake. The motion was described as like that of a corkscrew. All the witnesses say that the top of the stack vibrated in a circular or elliptical manner, thru a space of at least 2 diameters; that is, one diameter on either side from the mean position. The stack is built on hard ground, and bolted to a heavy brick foundation. The motion, therefore, gives the wave distortion of the solid earth, a motion of 6 feet at the top corresponding to a wave distortion of one-twenty-fifth part of the radius, or 2° 3'.<sup>1</sup> If the stack be regarded as vibrating about its center of gravity, the angle will be about half as large. These figures correspond to the distortion of the earth's level surface produced by the passage of the earthquake waves thru the rocky crust."

<sup>1</sup> This appears to involve the assumption that the stack was rigid, which is inconsistent with the described corkscrew motion. A. C. L.



Other observations mentioned by Professor See which are indicative of the intensity of the shock are the agitation of the water which was thrown into sharp cones, and filled with bubbles due to the escape of gases from the underlying mud; the shaking of trees and telegraph poles as by a storm; the fright noticed in all persons and animals; the throwing down of unstable objects; the raising of dust from the ground, and the formation of a mist in a few places. The motion was not so violent that one could not stand, yet during the violent part of the disturbance walking was difficult. All objects had a hazy outline, owing to the rapidity of motion, and it is said that persons presenting this aspect offered a comical sight to the beholder. The forests were agitated as by a violent wind, and at first the motion of the trees was ascribed by some marines on watch to a rising storm.

*Vallejo Junction* (T. J. J. See). — This station is just across the straits from the southeastern end of Mare Island and has only a few houses, the injury to which was not at all considerable. The intensity here was about the same as at Mare Island and Vallejo, as might have been expected from the proximity of these places.

*St. John's Quicksilver Mine*. — At the St. John's Consolidated Quicksilver mine near Vallejo, the following observations are recorded by Mr. Alphonso A. Tregidgo, manager of the mine. The note is of special interest as this is the only case in which underground disturbances have been observed in mines as a result of the earthquake of April 18:

We felt the shock about 5<sup>h</sup> 15<sup>m</sup> A. M., first north and south, and then east and west. We are working only two shifts, and as the night men "come off" at 4 A. M., there were no men in the mine when it occurred.

Our main tunnel is 1,135 feet in from the mouth. It cuts the lode 367 feet below the croppings, and crosses N. 3° 30' E. At the end of this tunnel the old shaft was sunk 230 feet deep (vertical). The first 130 feet was thru the lode, the remaining 100 feet being in the "foot" or west wall, the lode going down to the east of the shaft. Within the year preceding the earthquake a new shaft was sunk which this main tunnel intersects 500 feet nearer its mouth, 160 feet below the surface. Right at this point the effects of the earthquake appear in the tunnel. The posts of the sets were "snapt off" about 8 inches from the bottom, and forced north for several sets. Our tunnel is timbered thruout 8 x 8, sets 4 feet apart. The old shaft timber sets dropt on the east side from 2.5 to 3 feet. This shaft is double compartment. The wall plates are north and south, and end pieces east and west. Carrying the ends with them, the east wall plates dropt to the 180-foot level, so that all the sets above that level are now 2.5 feet low on the east side. (From a point 1,125 feet in the tunnel the center of this shaft is located 22 feet 5 inches E. 17° S.) We have repaired the tunnel, but the shaft is beyond repair. As we connected our new shaft with the old shaft workings below the main tunnel level on April 16, just two days before the earthquake, we fortunately have no need of the old shaft for working purposes, tho it will be necessary to keep it open a while for ventilation. Strange to say, our new shaft was not damaged at all. It is timbered from top to bottom nearly 400 feet; sets 4 feet apart, close lagged. Not a lagging even moved. From a point 610 feet from mouth of tunnel, the center of new shaft bears S. 76° 30' W. 14 feet 9 inches. No doubt considerable change has been caused by the earthquake in the old workings above the main tunnel, as our airways needed repairing in places.

*Benecia* (T. J. J. See). — The earthquake was decidedly more severe here than in Vallejo; 2 or 3 houses collapsed and half, or more than half, of the chimneys were thrown down. Major Bene't, U. S. A., Commandant of the U. S. Arsenal, informs me that he reported to the War Department over 20 chimneys on the Government houses in the military reservation either thrown down or so injured that they had to be taken down. These houses all stand on solid high ground, none of them being on land made by the filling in of loose earth. Some of the Government buildings were cracked and otherwise injured, but on the whole the damage was not very extensive. In Major Bene't's residence the furniture was considerably deranged, books were thrown down, bric-à-brac overturned and some of it broken. Such objects as dishes were frequently shaken off the shelves and crashed upon the floor.

At the entrance to the Arsenal grounds, the Gate House, used for the guard, is a round tower about 12 feet in diameter, made of brick and lined with a wooden ceiling. It was

built some 40 years ago, on a well-laid foundation going down to bedrock, which here underlies hard ground; yet the brick walls were badly cracked on every side. This guard-house stands on a high terrace, and the lower grounds appear to be alluvial deposits of the river.

In other parts of Benecia, brick houses built on hard ground were occasionally cracked. The town is somewhat spread out, some of it resting upon the alluvium near the river, the rest extending back over high rolling ground similar to that at the Arsenal. On the alluvial land the shaking was naturally most disastrous. A frame building near the water-tank, used for a saloon, collapsed; and a large cannery was so damaged that most of it had to be taken down. The water-pipe for the city was temporarily broken.

#### SACRAMENTO VALLEY.

*Red Bluff, Tehama County.* Population 2,750. (G. L. Allen.) — The earthquake awakened most sleepers. Quite a number of clocks were stopt. The chandeliers were caused to move considerably and in all directions. The tall head of a bed slammed against the wall, frightening the occupants. A lady tried to get up to keep an electric-light bulb, which was swinging violently, from striking a stove-pipe 2 feet distant from the cord; but she became dizzy and had to return to bed. The bulb did not strike the pipe. (J. H. Smith, Weather Bureau Observer.) No objects were overthrown, but hanging objects were caused to swing considerably. There was but one rather sharp jar, or shock, the direction of which is unknown. The inhabitants of the town were not unduly alarmed.

*Corning, Tehama County.* Population 1,000. (B. D. Wilkinson.) — I was awakened by what was at first thought to be wind moving the building; then I felt the bed and the building apparently roll in waves. Hanging electric lamps swung from south of east to north of west. Open doors swung for about half a minute.

*Chico.* Population 2,640. (W. M. Mackay.) — The shock here was quite pronounced, but not sufficiently so to do any damage. No chimneys were broken; nevertheless every house shook violently. I was awakened by the rattling of the weights in the windows. More than half the people interviewed say that the noise awakened them. Numerous clocks stopt, but no glassware or crockery was reported broken. In Chico Creek, adjoining the town, splashes on the bank indicated that there had been a violent commotion of the water. In places the water had been thrown several feet. The water-tank at the gas works was so disturbed as to cause the water to flow into the main, necessitating the pumping out of the main before service could be restored.

(E. Meyhew.) — I was in bed awake at the time of the shock. The motion was from north to south, and appeared to come in two waves, with an interval of about 6 seconds. The disturbance lasted about 15 seconds all together. It made windows rattle, and chandeliers and electric-light bulbs suspended by cords were caused to swing. It stopt 2 clocks in my store, one hanging on a southwest wall and the other on a southeast wall. All other clocks in the store continued going. A rumbling sound was heard thruout the disturbance.

*Willow\*.* Population 895. " (A. W. Sehorn.) — The motion increased until the weights in the window-frames rattled-considerably; trees swayed back and forth as in a hurricane for about 30 seconds, gradually diminishing. The movement appeared to be northeast to southwest, and was strongest near the middle. The clock was stopt, and the bed felt as if some one were pulling it. Chimneys were not injured. A rumbling noise preceded the shock.

Mr. G. K. Gilbert made a trip into the section of the Coast Ranges lying between the Clear Lake district and the Sacramento Valley. His purpose was to verify the report of a large rift said to have been made in St. John's Mountain by the earthquake. The rift was not found, tho sought for to the summit of the mountain; and the descriptions of it as an opening 10 feet wide by 20 feet long indicate that it is something quite different from

the ordinary manifestation of earthquake violence. The people at the base of the mountain were incredulous as to the existence of the crevice and especially as to its creation at the time of the earthquake.

As an outcome of this trip, Mr. Gilbert contributes the following note on the intensity of the earthquake shock at various points in the territory visited.

At *Williams* (population 500) the shock was strong enough to awaken people but not to throw down chimneys. It is said that small cracks were made in the walls of the hotel, a brick building. The intensity was about the same at Maxwell, population 300; Leesville; and Stony Ford, population 100. At Fouts Springs, 10 miles west of Stony Ford, only a few persons recognized the jar as due to an earthquake, and its identification was questioned by others until the news of the San Francisco disaster reached the place. As Stony Ford and Fouts Springs are near the east and south bases of St. John's Mountain, it is probable that the mountain was not severely shaken.

*Elk Creek, Glenn County.* Population 200. (P. E. Friday.)—The shock was very light. Some people heard windows rattle and noticed open doors swing slightly.

*Colusa.* Population 1,441. (Mrs. S. L. Drake.)—There was nothing overthrown, but water slopt from the tanks of the water-works on the north and south sides. The shock was so slight that only a few persons noticed anything more than a shaking, as tho some one had hold of the bedstead.

(E. S. Larsen.)—Many sleepers in Colusa were awakened, and some clocks were stopt, but there was no damage to chimneys and no glassware was broken. Window-frames in stores were in some instances displaced so as to leave a crack. Few cracks in plaster are reported. There is a general agreement that the vibrations were strong but slow and swinging. There is a fair agreement on the east and west direction for the vibrations. The jeweler had three pendulum clocks on the wall facing north. None of them stopt.

(Fred Roche.)—The shock in the central part of Colusa County lasted over a minute. There was only one continuous disturbance, but its intensity was strongest in the middle part. It caused windows to rattle, the bed to move, and hanging objects to swing, and overthrew some ornaments, but did not affect chimneys.

*Meridian, Suiter County.* Population 500. (T. F. Taylor.)—Two shocks were felt, the second being the stronger. No objects were overthrown.

*Marysville, Yuba County.* Population 3,497. (R. F. Watson.)—I was indoors, standing on the floor and stooping over when I felt quite a distinct tremulous motion for about 10 seconds before the main shock, causing a dizzy feeling. The shock itself started rather heavy and was jerky; it then became lighter until the second part of the shock came, with a rocking motion. The movement of the floor tipt me toward the southeast. No noise was heard. Windows and chairs rattled; electric-light bulbs suspended by cords first vibrated like a pendulum and then described a circle; and the pendulum clock stopt.

(A. B. Martin.)—The shock was sufficiently intense to arouse people from sleep, but no chimneys were broken nor was property injured.

*Yuba City, Sutler County.* Population 600.—The earthquake was generally felt; some sleepers were awakened and some clocks stopt. Movable objects were shaken. Water in horse-troughs was thrown several feet in an east and west direction in two cases, the troughs being oriented north-south and east-west respectively.

*Black's Station, Yolo County.* Population 300. (S. P. Cutter.)—No objects wore overthrown, but hanging objects were caused to swing in a circle. There were 2 maxima, of which the first was the stronger; and a vertical movement was felt.

*Knight's Landing, Yolo County.* Population 500: (L. T. Shamp.)—While no large objects were overturned, small ornaments were thrown in all directions, and the shock was violent enough to stop several clocks. There was more than one maximum, tho the first was the strongest. The water in the Sacramento River rose to a height of 3 to 4 feet in long sweeping swells.

*Lincoln.* Population 1,061.—Clocks were stopt.

*Fairoaks, Sacramento County.* Population 300. (L. M. Shelton.)—There was one straight shake, which was very light. People scarcely knew there was an earthquake.

*Sacramento.* Population 29,282. (J. A. Marshall.)—I was awakened by my wife's remark that she believed we were having an earthquake. Thus aroused, I lookt up and the chandeliers seemed to be oscillating several inches in an eastward and westward direction. This continued, together with the rattling of the window weights in their boxes, for about a minute, during which time we arose and observed and verified the phenomena. The oscillation slowly decreased, and ended in two considerable jars, with appreciable intervals between. The clock on the mantelpiece facing westward stopt. It is, I think, so constructed that it would not have stopt had the vibration been northward and southward. The shock here would grade V, Rossi-Forel scale; or, more properly, between V and VI; but there was no breakage. Another slight shock occurred soon after 8 A. M., April 18, and a more noticeable one at 3<sup>h</sup> 25<sup>m</sup> P. M., April 19, of about grade III; the motion in this case seemed to be north and south.

(E. C. Jones.)—The damage at the gas plant was very slight. The gas-holders rocked to such an extent that considerable water was thrown out of the tanks, and the seals of the holder sections were partially emptied, allowing gas to escape. No damage was done to the manufacturing apparatus nor to the street mains.

(Hiram Miles.)—I was looking at the clock when the shock commenced. It lasted 2 minutes and 17 seconds, the first half being oscillatory and the second half a tremor. The movement was decidedly northwest to southeast.

(Charles A. Hendel, C. E. and M. E.)—I was on the second floor of the Western Hotel. I jumped out of bed, opened the door, and placed a chair against it, so that it would not close on me while I was dressing. I had to hold on to the bed to get drest. The oscillation appeared to me to be like the shaking of a mouse or a rat, by a cat.

*Gait, Sacramento County.* Population 350. — The shock lasted 45 seconds.

*lone, Amador County.* Population 806. (J. F. Scott.)—The shock awakened and alarmed people. There were two distinct maxima, of which the second was the stronger. The direction of movement was north. No objects were overthrown.

(Win. Randall) The vibration was gentle but of such amplitude as to attract unusual attention. It was seemingly in a north and south direction, and estimated to continue for 20 or 30 seconds.

*Suisun, Solano County.* Population 625. (Mr. Sheldon.)—The shock awakened nearly every one, threw 2 or 3 chimneys, and damaged perhaps 25 per cent of the chimneys so that they required repairing. Masonic Hall had a few bricks thrown from an ornamental arched window. The plaster was much cracked, but there was no serious damage. Thruout both Suisun and Fairfield considerable plaster was cracked and even thrown down; a few bottles were thrown from shelves; a large proportion of the clocks were stopt; and a few windows were broken. There was no agreement as to direction. Vibrations were long and rolling.

*Elmira, Solano County.* Population 317. (E. S. Larsen.)—Most sleepers were awakened but no damage was done. There are few brick chimneys, and none of them was thrown or cracked. No plaster was thrown down and no windows were broken. As there are only a few small houses in the town it is rather difficult to make an accurate comparison; but the shock was probably considerably less severe than at Suisun, and slightly less than at Vacaville.

*Vacaville, Solano County.* Population 1,220. (E. S. Larsen.)—About 12 chimneys were cracked or thrown, some plaster was cracked, most clocks were stopt, and probably all sleepers were awakened. Things were very seldom thrown from shelves. There is a general impression that the vibrations were east and west, and that they were of a slow rocking nature.

*Esparto*. Population 200. — Clocks were stopt.

*Capay, Yolo County*. Population 200. (E. S. Larsen.) — Sleepers were awakened and milk slopt over in pans, but no chimneys were thrown, no windows were broken, and no clocks were reported stopt.

(S. Schwak.)—There was one continuous shake from northeast to southwest, resulting in the spilling of milk from pans. No objects were overthrown.

*Guinda, Yolo County* (J. Jacobsen).—There was one continuous shake for about 25 seconds, the apparent movement being from northwest to southeast. A vertical upward motion was also experienced. Nothing was overthrown.

*Rumsey, Yolo County* (J. M. Morrin). —The movement was from southeast to northwest. There were 2 maxima, the second being the stronger.

(E. S. Larsen.)—There was no damage whatever to buildings, but most sleepers were awakened. The vibrations were long and gentle.

*Woodland* (E. S. Larsen). —Most sleepers were awakened, but no chimneys were thrown and no glass was broken. A few clocks were stopt, one of which faced east. All agree that the vibrations were slow and gentle and of a rocking nature. Mr. J. L. Spohn states that he was awake at the time, and observed an electric-light globe hung by a cord. At first the globe vibrated east and west, and then had a rotary motion.

*Davisville* (E. S. Larsen). —Most sleepers were awakened. One man reports 2 or 3 chimneys cracked, but every one else denies this. Some plaster was cracked and doors were jammed so that they required resetting. No glass was broken. Various observers report vibrations from east to west or north to south, but they do not agree. All report the vibrations long and slow.

*Maine Prairie, Solano County* (Mrs. A. Rattike).—No damage resulted from the earthquake. A gentle swing was experienced, the motion of which was from southwest to northeast, as evidenced by waves generated on the surface of the water on the overflowed land.

*Rio Vista, Solano County*. Population 682. (J. C. Stanton, C.E.) —The character and effects of the shock are described in a note published in the Climatological Report of the U. S. Weather Bureau for April, 1907, as follows:

The shake was very severe. It commenced with a number of quite long vibrations from northwest to southeast and wound up with the figure 8 motion which often accompanies seismic disturbances. It was quite difficult for persons to maintain their footing; but strange to say, nothing was thrown down or overturned, which may be attributed to the gyrating motion. The duration was about 30 seconds, and I am convinced that had it continued 30 seconds longer hardly a house would have been left standing in town. Some lumber piles were thrown down in a lumber yard situated upon a pile wharf, where the disturbance seemed worse than anywhere else; and the water-tower, 60 feet in height, consisting of 2 large tanks containing 100,000 gallons, was seen to sway violently.

*Collinsville, Solano County*. Population 300. (Joseph Antonini.)—Collinsville is on the peat of the tule land, with hard clay 2 feet below the surface. The largest building in town, a hotel built on piles, was totally wrecked. Chimneys and water-tanks were overthrown. The movement was east.

#### NORTHERN SIERRA NEVADA.

*Butte County*. — At John Adams, population 75, and at Berdan, a slight trembling of the earth is reported. At Paradise, population 100, Mr. F. W. Day reports that hanging objects vibrated violently, and that a "sinking sensation" was experienced. At Stanwood the shock, according to Mr. S. E. Rowe, was very slight and noticed by very few people. At Honcut, population 100, a slight shock is reported by Mr. D. B. Robb.

*Quincy, Plumas County*. Population 516. (L. A. Barrett.) — The shock was heavy enough to awaken a few people, but was not felt by the majority of the inhabitants. Mr.

J. W. Street, watchmaker, reports that his clock stopt in consequence of the shock. This was the only clock in town that stopt.

Other points in Plumas County at which the earthquake is reported to have been felt as a slight shock are Greenville, population 640; Taylorsville, population 130; Kettle; and Beckwith, population 100. At La Porte (population 300), Mr. Oscar Freeman says: "The shock was very light. There were but few persons in town that felt it, perhaps a dozen. It made the house creak as would a sudden gust of wind, set the hanging lamp swinging, and seemed to have a twisting or circular motion, as near as I could judge."

*Sierra County.* — Slight shocks are reported to have been felt at Table Rock, by John K. Walls; and at Allegheny (population 200), by W. A. Clayton. At Loyalton (population 100), Mr. J. J. Miller reports a confused shock in three parts. An electric bulb hanging from the ceiling was caused to swing in a circle. At the west side of Sierra Valley, in the tule land, the quake was more severe, and caused dishes to rattle and loose objects to sway.

*Nevada County.* — A slight shock is reported at the following points: Fernley, by G. V. Robinson; French Corral (population 150), by W. E. Moulton; Grass Valley (population 4,719), by C. W. Kitts; Chicago Park, by E. F. Sailor; North Columbia, by Mrs. C. J. English; Washington (population 500), by J. H. English; and Floriston, by W. I. Sunburnt. At Boca (population 50), Mrs. A. E. Daswell reports that the shock comprized only one movement, which lasted about one minute and was strong enough to make an electric-light bulb swing. At Truckee (population 1,600), W. S. T. Smith reports that the shock was felt by a number of people. Windows rattled, hanging objects swung, and a clock stopt. No objects were overthrown.

*Placer County.*—According to the reports received, the shock seems to have been less generally felt than to the north or south. A slight shock, noticed by few people, is reported to have been felt at Newcastle, population 600; Auburn, population 2,050; Yankee Jim, population 150; and Emigrant Gap, population 60.

*Georgetown, Eldorado County.* Population 400. (C. M. Fitzgerald.) — The shock was distinctly felt by most people, and the disturbance was sufficient to awaken those not already up. No objects were, however, overthrown. The movement was decidedly from north to south. The duration was estimated at 30 seconds.

*Nashville, Eldorado County.* Population 50. (J. C. Heald.) — But few people felt the quake. Many spoke of some disturbance having awakened them. The few who were awake at the time felt the jar, but did not know what it was. The shock was felt somewhat more distinctly to the north and south of Nashville.

*Pino Grande, Eldorado County* (W. E. Borham.) — Few felt the shock, which was light. Hanging objects swayed back and forth. No objects were overthrown.

*Drytown.* Population 300. (Allen Me Wayne.) — The shock was felt by only one or two people in town.

*Milton, Calaveras County.* Population 200. (J. H. Southwerk.) — The shock was distinct. There were 2 maxima, and the second was probably the stronger. The direction of movement was east and west. Mr. S. D. Hildebrand, who was on the bottom-land of the Calaveras River, 3 miles west, felt a more violent shock, but no damage was done.

*Railroad Flat, Calaveras County.* Population 200. (R. B. Knox.) — Mr. Knox was awakened by a smart shock which shook his bed for nearly a minute.

*West Point.* Population 266. (Mr. Balsley.) — A pail of water two-thirds full slopt over; pans rattled, and the clock was moved on the wall. The shock moved Mr. Balsley's bed from side to side, southwest to northeast.

A shock was reported, without further details as to its effects, at Campo Seco; Esmerelda; Mokelumne Hill, population 575; Nassau, population 50; North Branch; and Vallicita, population 500.

*Gold King Mine* (Henry Seeman). —Near Gold King Mine, sec. 26, township 6 N., Range 14 E., a moderate shock was felt. This was, however, not noticed by any of the 15 persons at the mine, less than 0.25 mile away, nor by the night shift in the mine, and awakened no sleepers.

*Blanchard, Tuolumne County* (Mrs. C. E. Blanchard). — One chimney was damaged slightly, but the shock otherwise did no damage. The shock was light, tho generally felt in the surrounding country.

*Columbia, Tuolumne County*. Population 500. (J. W. Pitts.) — The shock was so light that those asleep did not feel it and did not wake up. Mr. Pitts and others who were up felt a slight shock and motion from north to south.

*Sonora, Tuolumne County*. Population 1,922. (J. E. Coover.)—The movement seemed to be an easy rocking one, free from jerks, with considerable amplitude. The earthquake was in full swing when Mr. Coover awoke; it held its maximum intensity for some moments, it seemed a half-minute, and then diminished gradually. A pendulum clock stopt.

*Tuolumne, Tuolumne County* (Capt. J. T. Thompson). — In the Turnback Inn, a large frame structure, some window glass was crashed diagonally, and sleepers were generally awakened. The movement was oscillatory and seemed to be east and west. At the Grizzly Mine, in the bottom of Tuolumne Canyon, about 1,000 feet below the town of Tuolumne, the shock was not felt.

*Jupiter, Tuolumne County* (Cornelius Quinlan). — Was awakened by the shock at 5<sup>h</sup> 14<sup>m</sup> A. M., and experienced a sliding back and forth from north to south for about 20 seconds after awakening.

*Sequoia, Tuolumne County* (Mr. Crocker). — Two prolonged light shocks were felt, of the nature of a pronounced tremble. Some members of Mr. Crocker's family did not feel it.

*Yosemite Valley*. — A slight shock was felt.

**DISTRIBUTION OF APPARENT INTENSITY IN SAN FRANCISCO.**

BY H. O. WOOD.

## INTRODUCTION.

In presenting the results of this study, the subject-matter has been taken up as follows: First, brief mention is made of the physiographic features of the city. Map No. 4, of the atlas accompanying the report of the Commission, shows the location of the city and its physiographic environment, also a segment of the Rift and of the fault on which the earthquake of 1906 was generated, and the position of a similar fault where the shock of 1868 originated. The city lies between these two zones of faulting. Then follows a note on the general geology of the region, illustrated by a geological map, No. 17 of atlas, prepared by Professor Andrew C. Lawson, on which is shown the areal distribution of the more important rock formations and of the districts of "made" land. Then comes the description and classification of typical destructive effects examined in the field. An intensity scale is discust, and its relationships to the Rossi-Forel and Omori scales are determined as well as possible. By critical comparison with Omori's scale, approximate values are fixed for the grades in terms of acceleration. Illustrating this discussion, map No. 19 of the atlas, showing the areal distribution of intensity in terms of an especially devised scale, presents graphically the results of the investigations in the city. The methods employed in the preparation of the map are set forth; also the manner in which the intensity scale was utilized. In map No. 18 are shown several geological cross-sections with corresponding intensity profiles. As vertical coördinates of the latter, values of the grades determined approximately in terms of acceleration were utilized.

Following the general discussion of the intensity is a detailed description of the evidence which characterized various localities and determined the intensity grades ascribed to them.

Next are discust details of evidence in the localities where very high intensity prevailed, which are of general interest owing to the suggestions they offer, the problems they raise, or the warnings they proclaim.

## PHYSIOGRAPHY.

The San Francisco peninsula rises with bold relief from the level of the sea to hill summits varying in altitude between 100 and 1,800 feet, with the broad Pacific to the west of it, the waters of San Francisco Bay to the east, and the Golden Gate on the north. Southward, trending slightly east, the peninsula runs for several miles, merging finally with the hills of the Santa Cruz Range which mark the eastern limits of the Santa Clara Valley. On the western shore, promontories such as Point Lobos, Mussel Rock, San Pedro Point, and Montara Point, where rock-cliffs rise out of the surf, alternate with stretches of smooth beach line. At the north, the hills come down to the shore, forming rocky points: Point Lobos, where the Cliff House stands; Fort Point, marking the narrowest part of the Golden Gate; and the minor promontories of Black Point and Telegraph Hill farther east. The eastern shore is marked by prominent rock ridges extending out into the Bay, while between these, reaching well back into the hills, are sharply limited valleys cut down to the level of the sea and filled with deep deposits of alluvium, thus forming a gontly sloping floor from which the hills rise abruptly. Before the building of the city, tide marshes with their little tidal creeks occupied the floors of these valleys, near their mouths.



The most important of these is the relatively large Mission Valley, opening into the Bay between Rincon Point and Potrero Point and extending back westward and then southward, with a minor fork to the northwest) fully a quarter of the way across the peninsula. Mission Creek, with its lagoon and contiguous marsh, before it was filled to provide street and building sites, extended from the Bay shore around the northern extremity of the hills of the Potrero. Another long narrow marsh occupied a part of the floor of Mission Valley, stretching eastward from the present site of the Post-office building for several blocks, and then turning southward to the old Bay shore. This marsh also has been filled to provide building sites. Another dominant valley is that of Islais Creek, stretching back to the southwest between the hills of the Potrero and those of Hunters Point. This valley is outside the city proper.

The city and county of San Francisco occupy the northern end of the peninsula, bounded on the south by an arbitrary east-west line some 7 miles south of the Golden Gate. The city, properly speaking, occupies the northeastern third of this area, covering the summits and flanks of the sandstone hills known as Telegraph Hill, Nob Hill, and Russian Hill, on the north; and other unnamed summits on the west. It covers also the floor of Mission Valley and reaches well up on the flanks of the hills which culminate in the center of the area. On the outskirts of the city proper, except in the southwestern part, are small detached groups of dwellings in the hills or on the sands.

Market Street is a broad thoroughfare running southwestward from the Ferry Building and the wharves, at the northeast corner of the city, thru Mission Valley to the flanks of the high hills in the center of the area. About the lower part of Market Street is the commercial center of the city. The City Hall, situated about 1 block north of this broad highway, and about 12 blocks southwest of the Ferry, was not far from the center of the city proper.

The zone of faulting where the recent earthquake had its origin past under the sea from a point near the head of Bolinas Lagoon, 12 or 15 miles northwest of the Golden Gate, to a point half a mile north of the little headland of Mussel Rock, about 8 miles south of Point Lobos. The map, No 4, shows its location.

The entire area of the city and county is east of the fault-zone. The southwest corner of the area is less than a mile distant from it. The vicinity of the Ferry Building, at the foot of Market Street, was the most remote of any point in the whole area, being between 9.25 and 9.75 miles away. The site of the City Hall is from 7.5 to 8 miles from the fault. The Cliff House, at Point Lobos, the most western point of the area, is about 3 miles east of it. Fort Point lies between 5.75 and 6 miles east of it. Potrero Point and Hunters Point, as well, are about 8.5 miles from the fault. Hunters Point is the most easterly point in the district.

#### GEOLOGY.

It is desirable to insert here a brief abstract of the geology of the northern part of the San Francisco peninsula, for it will appear that the effects produced by the earthquake were largely influenced by the character of the underlying formations. Map No. 17 shows the distribution of the geological formations at the surface. It shows also the areas of "made" land. These areas were determined by plotting the shore line shown on the accurate chart published in 1853 by the U. S. Coast and Geodetic Survey, upon the latest accurate chart of the same bureau. In these districts the materials forming the surface have been transported to their present position by human agency. The depth or thickness of this "filled" stratum is variable and, for the most part, not definitely known.

A little study, comparing the areas of rock with the topographic contours, shows that all the hills are of firm rock, mostly coated with a veneer of soil and vegetation, but frequently outcropping at the surface. In general, their lower flanks are more and more thickly covered with loose sand and alluvium the nearer approach is made to the floor of

the valleys or the districts of sand-dunes. At the lower levels such loose materials cover the whole area very generally. The thickness of these strata must be notably variable, considering the uneven configuration of the rock surface where it emerges from this mantle, since it is probably no less irregular beneath the covering. Very little information is available concerning the depths to which these uncemented materials extend. A well at the United States mint is about 176 feet deep and is believed not to have reached bedrock. A boring that was sunk at the corner of 7th and Mission Streets past thru sand and clay to a depth of 264 feet, but did not reach bedrock. In general the sands and clays fill deeply the major valleys, Mission and Islais. The minor northwest fork of Mission Valley, called Hayes Valley along its lower part, is probably less deeply filled. This is certainly true of its upper reaches, to which, in this report, the name Upper Hayes Valley is applied. Minor valleys and gullies all over the area have thin coverings of sand and alluvium which quickly thin out where the slopes of the hills begin to rise steeply.

From the ocean inland for a considerable distance extends an area covered with sand-dunes. This district is limited irregularly at the east by the contour of the hills. The sands form a thick mantle near the ocean shore, which becomes thinner and thinner as it rises upon the lower flanks of the hills. As in the case of the materials filling the valleys, the rock floor upon which the sands rest is probably very irregular.

Of the hills, the northern ridge is carved out of the firm sandstone of the Franciscan series. Along this ridge are the summits of Telegraph Hill, Nob Hill, and Russian Hill, with other unnamed hilltops to the west, separated from each other by little saddle-like depressions in the surface. The outlying summits of Black Point and Rincon Hill appear to belong genetically to this ridge. This body of sandstone abuts on the west against a mass of serpentine, which forms a narrow range of hills stretching southeastward across the peninsula from Fort Point to Potrero and Hunters Points.

This serpentine is intrusive in the firm Franciscan rocks, chert, and sandstone. The southwestern boundary of the serpentine in the vicinity of Fort Point is determined by a fault which has a throw of about 1,000 feet. This fault may possibly extend quite across the peninsula along the southwestern limits of the serpentine, but the field evidence does not warrant any definite statement. The fault movement occurred so long ago that the present land surface gives no unequivocal indication of its position. Mission Valley cuts across the body of serpentine, separating the northern hills from the southern group. The northern group rises along the western boundary of Hayes Valley.

The central and southern hills, and the ridge at the northwest of the city, are carved intricately from firm Franciscan rocks, sandstone, and chert, commingled with minor bodies of irruptive rock of basaltic character.

The hills of the more remote southwest corner of the city and county are of softer rocks of more recent geological origin — sandstones and shales of the Merced formation. These are relatively little cemented. Readers interested in a more complete account of the geology should consult the detailed report on this peninsula.<sup>1</sup>

#### DESTRUCTIVE EFFECTS AND INTENSITY SCALES.

To some extent the earthquake caused damage to buildings and other structures in all parts of the city and county of San Francisco. The whole area was decidedly within the destructive zone. Still, over a large part of this area, far the larger part, the damage was slight both in amount and character. Almost everywhere chimneys were thrown down or badly broken, but in a few small localities most of the chimneys withstood the shock. Some probably were unhurt. Plaster on walls and ceilings was very generally damaged. So, probably, were frail partition walls and chandeliers, crockery and fragile household furnishings. Such effects were typical of large sections of the city. There

<sup>1</sup> The Geology of the San Francisco Peninsula, by Andrew C. Lawson, 15th Ann. Rept., U. S. G. S.

were relatively small districts, however, in which brick and frame buildings of ordinary construction were badly wrecked or quite destroyed. Pavements were fissured, buckled, and arched. Sewers and water-mains were broken. In places, portions of streets were moved laterally several feet out of place. Well-ballasted street-car tracks, equipped with 8, 10, or 11 inch rails, were arched and flexed or thrown into shallow wave forms. The whole land surface, sometimes for several blocks together, was deformed into shallow waves of irregular extension, length, and amplitude. Effects of this degree of violence were pretty closely confined, as has been stated already, to areas of "filled" or "made" land. Such characterize, therefore, only a small portion of the city; but, as it happens, areas of commercial importance and of special interest for the scientific purposes of this inquiry. In consequence they will require a relatively large share of attention.

These destructive effects vary in degree from place to place thru the whole range between the extremes cited. In some cases this variation is best shown by the character of these effects; again by the frequency of their occurrence. The change from strong effects to weak sometimes takes place rather abruptly within the distance of a block or two, or less. Commonly the localities where very violent effects were produced are themselves pretty sharply limited. In such cases, however, there is still a noticeable variation in the sort and amount of damage resulting at different points just outside their limits, along their peripheries. At other places the destructive effects change gradually thru a distance of several blocks.

This areal variation in the degree of damage indicates clearly a like variation in the intensity of the shock. The effects produced are the direct results of the intensity manifested, since where nearly all kinds of structures are to be found in all districts, of whatever intensity, such factors as the individual strength of the injured structures must practically cancel in the aggregate result. Consequently the destructive effects furnish a measure of the intensity, not very precise, it is true, but the best available, since no seismographic instruments were maintained in the city. By a classification of these effects different grades of intensity can be recognized and defined.

Several such classifications have been made by seismologists for this purpose. The best known of these is the Rossi-Forel intensity scale, which provides ten scale numbers. The first defines a shock just barely perceptible to a sensitive observer, or one recorded by a sensitive seismograph; the tenth, a great disaster. The four highest numbers of this scale, as republished by the present Commission in its Preliminary Report, are as follows:

VII. Violent shock, overturning of loose objects; falling of plaster; striking of church bells; some chimneys fall.

VIII. Fall of chimneys; cracks in the walls of buildings.

IX. Partial or total destruction of some buildings.

X. Great disasters; overturning of rocks; fissures in the surface of the earth; mountain slides.

The range of intensity in the city did not exceed these limits. Probably it did not reach the higher numbers recognized by the scale number X. In only a few small localities were the minimum values of scale number VII prevalent. It is easy to see, however, that this scale distinguishes its three upper scale numbers in vague terms, particularly with regard to effects likely to be produced in a modern city. For this reason it was found unsatisfactory for the investigations in San Francisco.

A scale of greater merit is that devised by Professor Omori, of Tokyo, given below:

No. 1. Maximum acceleration is 300 mm. per sec. per sec. People run out of houses; brick walls of bad construction are slightly cracked; plaster of some old dozo (godowns) shaken down; wooden houses so much shaken that cracking noises are produced; trees visibly shaken; water in ponds rendered slightly turbid in consequence of the disturbance in the mud.

No. 2. Maximum acceleration is 900 mm. per sec. per sec. Walls in Japanese houses cracked; old wooden houses thrown slightly out of the vertical; tombstones and stone lanterns of bad construction overturned; in a few cases changes are produced in hot springs and mineral waters; ordinary factory chimneys not damaged.

No. 3. Maximum acceleration is 1,200 mm. per sec. per sec. About one factory chimney in every four is damaged; brick houses of bad construction are partially or totally destroyed; a few old wooden dwellings and warehouses totally destroyed; wooden bridges slightly damaged; some tombstones and stone lanterns overturned; shoji (Japanese paper-covered sliding doors) broken; roof tiles of wooden houses disturbed; some rock fragments thrown down from mountain sides.

No. 4. Maximum acceleration is 2,000 mm. per sec. per sec. All factory chimneys are broken; most of the ordinary brick buildings partially or totally destroyed; some wooden houses totally destroyed; wooden sliding doors and shoji mostly thrown out of their grooves; cracks 2 or 3 inches in width, in soft or low ground; embankments slightly damaged here and there; wooden bridges partially destroyed; and ordinary stone lanterns overthrown.

No. 5. Maximum acceleration is 2,500 mm. per sec. per sec. All ordinary brick houses very severely damaged; about 3 per cent of the wooden houses totally destroyed; a few *tera*, or Buddhist temples, are thrown down; embankments severely damaged; railway lines slightly curved or contorted; ordinary tombstones overturned; *ishigaki*, or masonry walls, damaged here and there; cracks 1 to 2 feet in width produced along river banks; water in rivers and ditches thrown over the banks; wells mostly affected with changes in their waters; landslips produced.

No. 6. Maximum acceleration is 4,000 mm. per sec. per sec. Most of the *tera*, or Buddhist temples, are thrown down; 50 to 80 per cent of the wooden houses totally destroyed; embankments shattered almost to pieces; roads made thru paddy fields so much cracked and depressed as to stop the passage of wagons and horses; railway lines very much contorted; wooden bridges partially or totally destroyed; tombstones of stable construction overturned; cracks a few feet in width formed in the ground, accompanied sometimes by the ejection of water or sand; earthenware buried in the ground mostly broken; low grounds, such as paddy fields, very greatly convulsed both horizontally and vertically, sometimes causing trees and vegetables to die; numerous landslips produced.

No. 7. Maximum acceleration is much above 4,000 mm. per sec. per sec. All buildings except a very few wooden houses are totally destroyed; some houses, gates, etc., projected 1 to 3 feet; remarkable landslips produced, accompanied by faults and shears of the ground.

In the foregoing scale, in addition to these definitions by destructive effects, it will be noticed that a range of values for the *acceleration* is assigned to each scale number. These acceleration values have been tested experimentally by Professor Omori, and found accurate within narrow limits. Consequently it is called an *absolute* scale. It is the best intensity scale yet proposed. Since, however, it is defined in terms of damage produced upon Japanese structures, it would require constant critical interpretation in use in an American city. For this reason, it is believed to be not so well adapted to the purposes of this investigation as the scale proposed below. This is especially true since the values of the acceleration necessary to produce the destructive effects encountered here have not been determined by experiment. A use of the absolute scale would, therefore, pretend to an accuracy not attained with any certainty. The following scale will be referred to as the San Francisco scale:

*Grade A. Very riotful* — Comprizes the rending and shearing of rock masses, earth, turf, and all structures along the line of faulting; the fall of rock from mountain sides; numerous landslips of great magnitude; consistent, deep, and extended fissuring in natural earth; some structures totally destroyed.

*Grade B. Violent.* — Comprizes fairly general collapse of brick and frame buildings when not unusually strong; serious cracking of brick work and masonry in excellent structures; the formation of fissures, step faults, sharp compression anticlines, and broad, wave-like folds in paved and asphalt-coated streets, accompanied by the ragged fissuring of asphalt; the destruction of foundation walls and underpinning structures by the undulation of the ground; the breaking of sewers and water-mains; the lateral displacement of streets; and the compression, distension, and lateral waving or displacement of well-ballasted street-car tracks.

*Grade C. Very strong.* — Comprizes brick work and masonry badly cracked, with occasional collapse; some brick and masonry gables thrown down; frame buildings lurching or listed on fair or weak underpinning structures, with occasional falling from underpinning or collapse; general destruction of chimneys and of masonry, brick or cement veneers; considerable cracking or crushing of foundation walls.

*Grade D. Strong.* — Comprizes general but not universal fall of chimneys; cracks in masonry and brick work; cracks in foundation walls, retaining walls, and curbing; a few isolated cases of lurching or listing of frame buildings built upon weak underpinning structures.

*Grade E. Weak.* — Comprizes occasional fall of chimneys and damage to plaster, partitions, plumbing, and the like.

This scale obviously is simply a classification of the phenomena observed. It defines as many grades as the facts seemed to express in this field. It is more finely subdivided than the Rossi-Forel scale and, for conditions in a modern city, the definitions are better framed. It has less intrinsic merit than the Omori scale, for both scales cover a similar range of destructive effects, but the subdivision is finer and more evenly spaced in the case of the Omori scale. Also the grades of the San Francisco scale can not be fixed by values of the acceleration, except approximately by comparison with the absolute scale. The fact, however, that it does not pretend to absolute values seems a point in its favor under the circumstances. And it is a practical scale for the phenomena dealt with.

Altho rigorous values can not be obtained by such means, it is desirable to subject the grades to careful comparison with the numbers of the Omori scale in order to determine reasonably close acceleration values for them.

A comparative study of the 3 scales is summarized diagrammatically in the accompanying table at the top of next page.<sup>1</sup>

Some of the effects which serve to define Grade A are weaker than the maximum effects defining No. 6 of the absolute scale; and nowhere, not even in the vicinity of the fault, were most buildings totally destroyed.

Grade B covers a wide range. Perhaps if the initial shock had been a little stronger; it could have been subdivided with some certainty.

Grades C and D cover each a slightly lower range of values than the scale numbers 3 and 2, to which they correspond most closely.

Grade E, as defined, is more narrowly limited than No. 1.

These values, despite their lack of precision, constitute the best approximation to an absolute measure of energy developed, for each grade of intensity, which it appears practicable to attain. There were no instruments of precision to record the character and amount of the motion of the shock, hence estimates of other sort than this seem difficult to make. The fact must not be lost sight of, however, that it is only an estimate, based upon the interpretation of a series of destructive effects produced in very variable media under variable conditions and then compared with a similar series of destructive effects produced in structures of a different sort, for which pretty accurate acceleration values had been determined experimentally.

---

<sup>1</sup>The definitions of the Omori absolute scale and the information about it are taken from the book on Earthquakes in the Light of the New Seismology, by Major O. E. Dutton.

E. OSSI-FOREL SCALE.	OMORI SCALE.	SAN FRANCISCO SCALE.	ACCELERATION <i>mm.</i> PER SEC. PER SEC.
10	No. 7	Grade A	4,000
	No. 6		3,000
	No. 5	Grade B	2,500
	No. 4		2,000
9	No. 3	Grade C	1,200
8	No. 2		Grade D
	No. 1	Grade E	

It may be perhaps well to point out that Grade D lies between Nos. VII and VIII of the Rossi-Forel scale. This grade characterizes the greater part of the city, as the intensity map shows. Grade B, equivalent to Nos. IX and X of the same scale, is characteristic of very small areas only. Grade A is not exhibited in the city proper.

Utilizing the San Francisco scale, intensity map No. 19 was prepared, which indicates the location and areal extent of the districts characterized by each grade of intensity. It presents graphically the results of the field work. In the field study, practically all of the city proper, including the large area devastated by fire, was thoroly traversed, excepting one or two isolated hilly localities where a brief examination showed no significant damage. Unbuilt districts were, of course, comparatively neglected, except where disturbances of natural objects were found or lookt for. Chimneys, buildings, streets, paving, curbing, sidewalks, car tracks, retaining walls, etc., were subjected to careful scrutiny, and such injuries as were observed were classified on the spot in terms of the San Francisco scale. The intensity indicated was recorded by a spot of color placed upon a field map of suitable scale (1,760 feet to the inch, or 1: 21,120). Many photographs were made, some of which appear as illustrations in this report.

Detailed field notes were made only when damage of unusual or striking character was encountered, or when it was perplexing. When effects were observed which seemed likely to be of value in analyzing the character of the earth motion, notes were made. Little indoor evidence was obtained or sought.

It will thus be seen that the field study, while adequate for the purposes in view, did rnot constitute an expert engineering investigation, dealing with specific details and location of damage. Frequently there was doubt as to what grade of intensity should be assigned to a given city block, because of conflicting or inadequate evidence in the field. This is particularly true of districts swept by fire, especially where the intensity was low; for most

of the effects which serve to define the lower grades were obliterated with, the structures in which they were developed. Where buildings were sparsely distributed, it was often hard to determine what grade of intensity was developed, for the evidence was scattering and heterogeneous. Nevertheless, the map is a pretty faithful representation of the distribution of intensity, and quite justifies the scientific and economic conclusions of a general nature that are drawn from it here.

On the map, color in northwest-southeast bars (A, B, C, D, E) represents districts marked by unequivocal evidence. Continuous lines indicate the position of well-determined boundaries between areas affected by different grades of intensity. Color applied in northeast-southwest bars (a, b, c, d, e) represents districts in which the evidence was scanty or circumstantial; and dotted lines indicate the position of boundary lines which were determined but vaguely by the phenomena in the field.

#### DETAILED DESCRIPTION OF THE EVIDENCE BY LOCALITIES.<sup>1</sup>

No district designated upon the map as exhibiting intensity of Grade E, so far as the writer could find, exhibited any destructive effects of a more violent kind than the fall of chimneys. The really typical measure of intensity for these localities was the cracking and falling of plaster. Without exception, these are places where the firmly cemented bedrock of the Franciscan formations is either exposed directly or covered with a very thin mantle of soil. This lowest grade of intensity does not, by any means, characterize all places where the firm bedrock is exposed at the surface. It was rather developed on the summit portions of the rocky hills. The tops of Telegraph Hill and Russian Hill are districts in which a large part of the chimneys withstood the shock. This was also the case with the upper slopes of the chert hills about the head of Market Street, at the center of the area. Scarcely any injuries resulted on the hills of the Potrero; and one or two small serpentine hills just north of Market Street were likewise immune. Similarly, the Hunters Point serpentine ridge was subjected to a shock of low intensity; at least, a hasty survey pointed to this conclusion, tho the evidence was sparse and not thoroly examined. San Bruno Mountain, however, was about as near to the zone of faulting as Point Lobos, where most of the chimneys were thrown. Intensity of Grade D is believed, therefore, to have been developed upon the summit of San Bruno Mountain.

The general fall of chimneys, slight cracking of brick work, and such damage, denoting intensity of Grade D, characterizes the northeastern half, or possibly two-thirds, of the city and county, except in localities where special conditions, chiefly lithological, modify it. Districts of exposed bedrock on the flanks of the hills, and of sand and alluvium wrapped as a thin mantle about their lower slopes, exhibited this degree of damage. Consequently a large area was affected by this grade of intensity which does not, in general, require detailed discussion; no violent nor specially significant effects being produced. Where, however, the loose earth covering is thicker, the magnitude and frequency of damage increases. Market Street, between Second and Fourth Streets; Mission Street, between First and Third Streets; and Howard Street, between Second and Third Streets, together with the blocks in the neighborhood of Market Street on Montgomery and Kearney Streets, Grant Avenue, Stockton and Powell Streets, form a district in which the effects denote an intensity only a little short of Grade C. A large proportion of the buildings were excellent structures which individually withstood the shock well. In consequence, it was difficult to draw a line in this region between districts marked by broken chimneys and cracked brick walls, and those where more serious damage was certainly developed. The resistant character of the excellent buildings and the thoro obliteration by the fire of evidence produced in poor structures, render the determination of the intensity as Grade D somewhat doubtful.

---

<sup>1</sup> The streets referred to in these descriptions are shown on map 20 of the atlas.

In the blocks adjacent to Point Lobos Avenue and Clement Street, between First Avenue and Sixteenth Avenue, in the sand-dune district, damage — mostly of Grade D — was prevalent. This locality is the part of the city nearest to the seat of the disturbance, and the cover of sand which rests upon the uneven bedrock is unevenly thick; therefore irregular variations of intensity are to be expected. Nevertheless it is not easy to fix the boundaries between Grade C and Grade D in this part of the city.

Along Oak and Fell Streets, and the Panhandle Parkway from Broderick Street west, the intensity closely approaches Grade C without seeming quite to reach it.

Along Washington Street and its immediate vicinity, from Baker Street west to Spruce Street, on the crest of the sandstone ridge, the intensity is higher than for most other localities of exposed bedrock. Fallen chimneys and cracks in foundation walls were more prevalent than in most areas so situated.

On bedrock at Point Lobos, also, the effects indicate an intensity pretty close to Grade C, but this locality is nearer the fault than any other Franciscan outcrop save the western slopes of San Bruno Mountain.

We may say in general, therefore, that Grade D is the intensity developed on bare rock foundations, or on rock only moderately coated with soil, in the northeastern part of the city and county of San Francisco.

In the low lands of the valleys, and along portions of the water-front, the sand and alluvial deposits are thicker and the destructive effects were increased in magnitude and in prevalence; also thruout a large part of the sand-dune tract at the west, wherever evidence was obtained, increased intensity was found to prevail.

All over Mission Valley and Hayes Valley, including Upper Hayes Valley, brick walls were cracked and some gables and walls actually fell. Buildings placed on weak underpinning were frequently displaced slightly from the vertical. In a few cases, weak frame dwellings collapsed as a result of the giving way of weak foundation structures. Most chimney stacks were broken. In no part of this large district was evidence of this kind lacking, altho the majority of the structures were fairly substantial frame dwellings, and were of course not seriously damaged. There was much indoor damage, but no investigation of this was undertaken.

At the outer margin of this area, marked by an intensity of Grade C, the destructive effects were weaker, indicating an intensity just above Grade D. Where the district adjoins localities which suffered a still severer shock, the damage was of greater magnitude and more prevalent. Besides this gradation there were, within the limits of the district, several little localities where the characteristic destructive effects were conspicuously numerous.

In the neighborhood of O'Farrell Street, between, say, Mason and Taylor Streets, brick work was sadly cracked. Photographs made before the fire (plate 87A) show that some building fronts were thrown out on O'Farrell Street in this vicinity. Many of the buildings hereabouts were mediocre structures at best, but injuries were too generally distributed to be ascribed wholly to structural weakness. The damage was not of great magnitude and did not indicate intensity of Grade B, so far as could be made out from the ruins after the fire.

Near the City Hall there was a small locality conspicuous for the damage produced. The City Hall itself made a picturesque ruin (plates 82 and 83A), as all the world knows, but the character of the construction was probably a large factor in its destruction. Nevertheless ugly cracks in other buildings near by indicated intensity somewhat higher than was common in the valley district as a whole.

Just south of Jefferson Square some weak buildings quite collapsed, and foundation walls were generally cracked and crushed. Wooden underpinning showed a tendency to lurch and throw buildings slightly out of the vertical. Similar effects prevailed along Folsom and Treat Streets for two or three blocks south of Eighteenth Street.



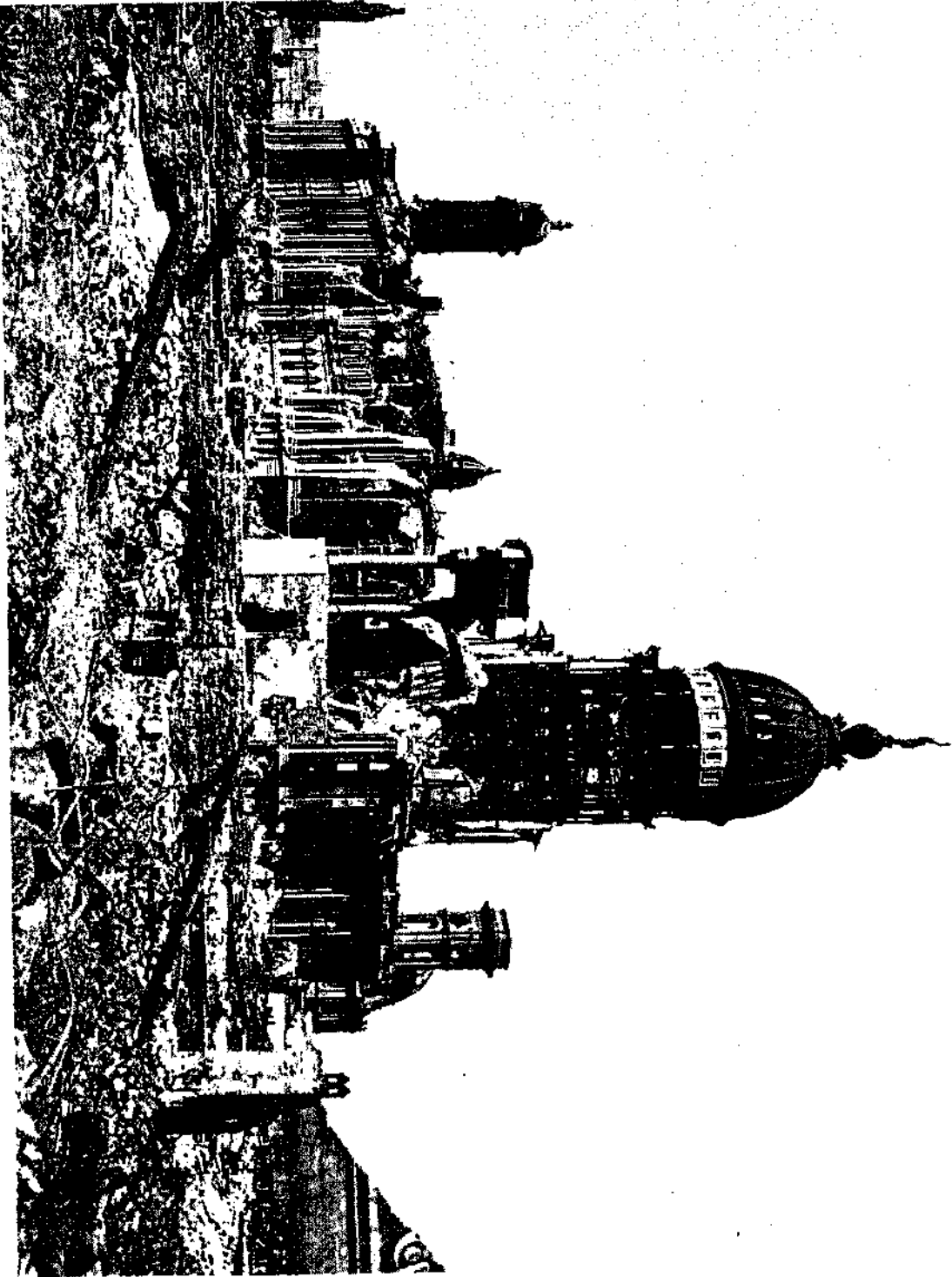

City Hall, San Francisco.



A. A near view of the wreck at the City Hall, San Francisco.



B. Cattle killed by falling masonry at time of earthquake, San Francisco.

The blocks between the old tide-marsh area, extending east from near the Post-office, and the former course of Mission Creek, give evidence in the form of cracked foundation walls, broken concrete cellar floors, etc., of intensity values high in Grade C. The fire did much to destroy evidence here, as it was a district of wooden dwellings.

From near the corner of Third and King, to the corner of Folsom and Steuart Streets, there is a narrow fringe of land constituting the water-front around Rincon Point. The land is partly natural and partly made. Few structures are found on it which are not built on piling, whether they be warehouses on the docks or good modern buildings. Some parts of the area are devoid of buildings. No evidence was disclosed in this tract indicating intensity higher than Grade C. Significant evidence was scarce. Cracked brick walls here and there served to fix the degree of intensity.

Onward to the north and to the west from the corner of Steuart and Folsom Streets, extends a narrow sinuous area around Telegraph Hill to the vicinity of Black Point, which is designated upon the map as affected by an intensity of Grade C. Such effects as badly cracked brick walls, some of which fell, the fall of cornices and gables, etc., are said to have been developed here. Such evidence as could be made out amid the fire ruins tends to confirm this. This region divides the water-front area of made land, where high intensity was developed, from sandstone hills, where a lesser shock was experienced. It will be discussed further in connection with phenomena of special significance.

A low-lying crescent-shaped area of alluvium and sand, with a little made land near the shore, extends westward from Black Point to Fort Point. South, east, and west the hills rise steeply. Formerly a tide-marsh completely separated the alluvial flats from the sandbar at the shore. Part of this, near its mouth, has been filled. Buildings are scantily distributed all over the area. Evidence in the form of structural damage is not, therefore, met frequently. The filled land of the tide-marsh is devoid of structures. There are several little localities in this district marked by damage denoting intensity of Grade B. These will be mentioned later. For the most part, frame buildings occasionally tilted a little out of the vertical, and cracked and crushed foundation walls are typical of the destructive effects found here.

Leading down into this area from near the corner of Polk Street and Pacific Avenue is a minor valley, once deeply trenched, but now modified by alluvial and artificial filling. Along its course most chimneys were thrown and foundation walls were cracked and crushed generally. Two little places, where intensity of Grade B was developed, are situated in the trough. They are discussed below.

A group of small areas, 4 in number, together with a small spur of Mission Valley, situated along a line extending northwest from about the junction of Sixteenth and Dolores Streets, is designated upon the map as characterized by intensity of Grade C. It chances that the northwest extremity of this line coincides with the location of an old fault-zone, mentioned above as partly determining the southwestern limits of the serpentine.

In one of these localities, practically bounded by Maple, Spruce, Washington, and California Streets, brick walls and foundations were cracked conspicuously. A building at the corner of Maple and Washington Streets had a balcony supported by pillars above its front entrance. This was thrown down, and the walls were cracked rather badly. It was probably a structure ill adapted to resist earthquake shock. Still it stands directly upon a bare ledge of serpentine, and upon similar rock in the Potrero, an equal distance from the fault, intensity of only Grade E was developed.

At the corner of Maple and California Streets, the Hahnemann Hospital, a new brick building, sustained severe damage, particularly the east wing. If neighboring structures showed any destructive effects comparable with this, intensity of Grade B would be indicated. But they do not. Some cause peculiar to the building itself is responsible for the exaggeration of the intensity. Probably the newness of the masonry was a contributory factor. The surface material here is sand, but it can not be very thick.

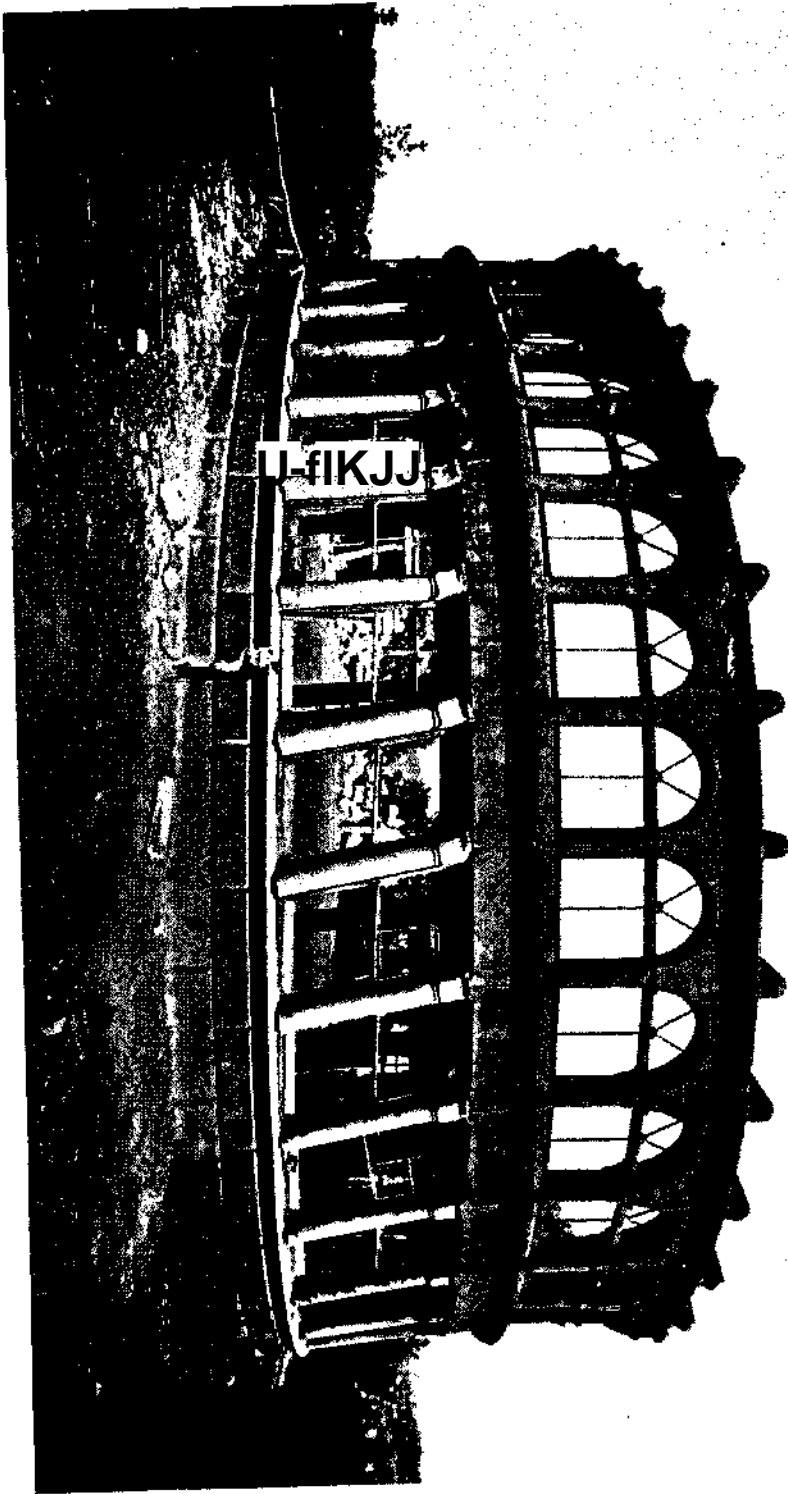

Observatory, Strawberry Hill, Golden Gate Park, San Francisco. W. K. Warden, Photo.

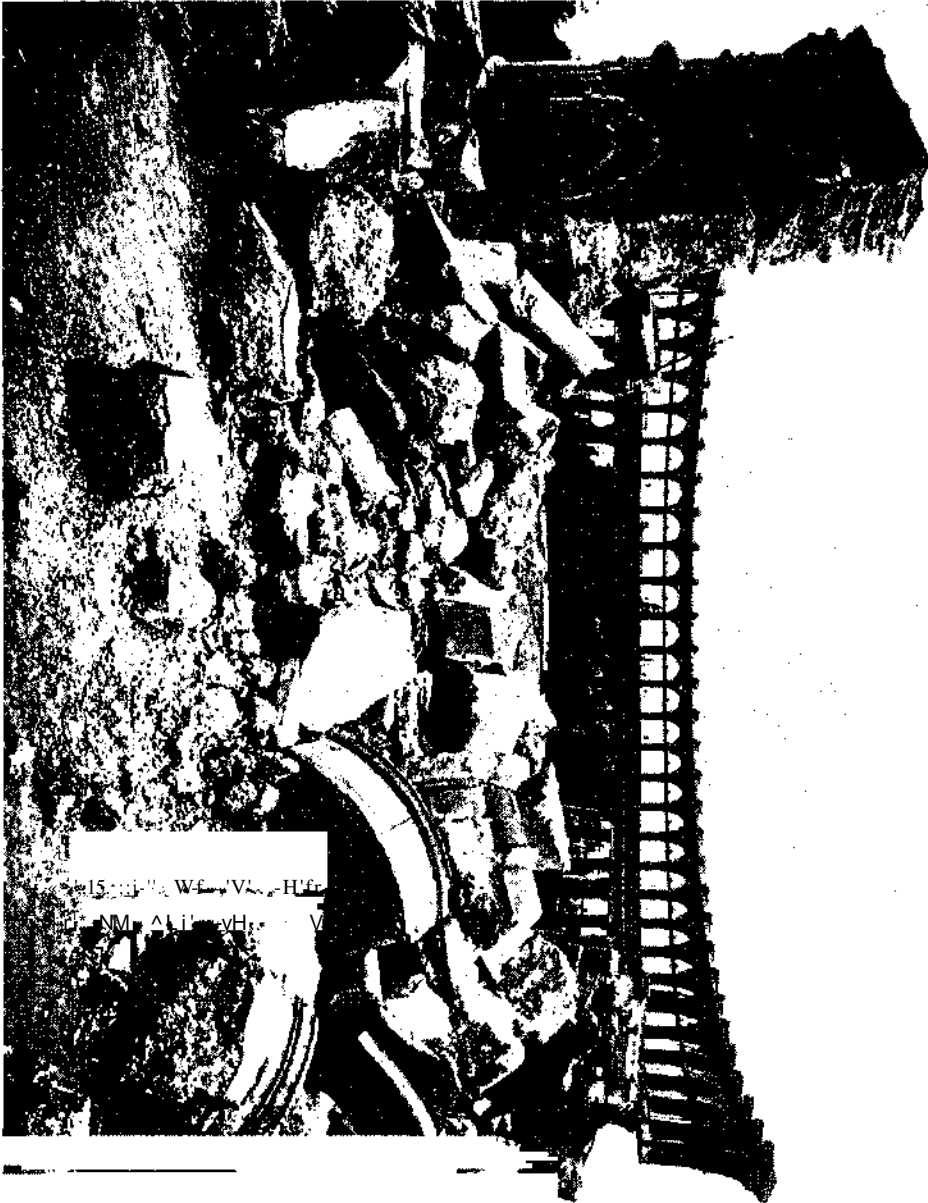

Observatory, Strawberry Hill, Golden Gate Park, San Francisco, W. E. Warden, Photo.

W. E. WARDEN  
O S Y - F W W





Eestaurant at Children's Playground, Golden Gate Park, San Franoisoo, W. E. Worden, Photo.



A. O Tamil Street, San Francisco, after earthquake and before fire.



B. Gearj Street, between FUmore and Steiner Streets, San Fraicisco. Buildings of mediocre onstruction on sand and allarium of no great depth. A. O. L.

out of place. Two or three smaller buildings in the immediate neighborhood were also notably damaged. Intensity equivalent to high values of Grade C was certainly developed hereabouts. In some cases it undoubtedly reached low values of Grade B. Yet the glass walls and roof of the conservatory, and of the aviary close by, were not appreciably damaged. This discrepancy shows clearly that some purely local factor determined the amount of damage.

Buildings on the beach sands near the Cliff House, close to the sandstone cliffs of Point Lobos, were strongly shaken. A small 1-story brick pumping station had its walls badly cracked and portions thrown down; its chimney stack also was broken. Weak underpinning in some neighboring frame buildings yielded perceptibly. Here also an abrupt transition is noticed from intensity of Grade C on the sands to Grade D on the sandstone cliffs.

Near Lakeview, fairly well built frame buildings on dune sand of unknown thickness were caused to lurch and shift their positions.

Ocean Avenue, between Ingleside and the sea, tho almost devoid of structures, shows by the unearthing, bending, and even breaking of drainage and water pipes, and by fissures in the road and asphalt paving, a change of intensity from Grade C to Grade B.

#### LOCALITIES OF LESSER IMPORTANCE AFFECTED BY INTENSITY OF GRADE B.

In the neighborhood of the crossing of Steiner and Sutter Streets, there is an irregularly bounded district a little larger than a city block in which several buildings not conspicuously weak were totally destroyed. St. Dominic's Church, at the corner of Steiner and Bush Streets, was a complete ruin, as the illustration (plate 92A) shows. Its steeple towers were ruined, its roof fell in, and all its walls were so badly cracked that it became a menace to the neighborhood. If the shock had occurred during the hours of religious service, few would have escaped from the building alive. Probably it was not a building of the most excellent construction; but, on the other hand, it did not appear to be built flimsily. It certainly suffered a most violent shaking. Near by small frame dwellings were pitched from their underpinning.

On Geary Street, just above Fillmore Street, two wooden-framed brick buildings standing side by side — the Albert Pike Memorial Temple (Masonic) and a Jewish Synagogue— were utterly wrecked, as the illustration shows. (Plate 87B.) The Girls' High School, near by on O'Farrell Street, at Scott Street, poorly and flimsily built, was badly damaged. Its walls were much cracked and portions of the gable walls were thrown down.

This district of Grade B intensity is on the floor of Upper Hayes Valley and is surrounded by a relatively broad area in which Grade C effects prevail. It lies near the base of the hills which hem in the valley on the east. The surface strata are sand and alluvium extending to no great depth, unless the slopes of the bedrock hills change suddenly where they pass under the mantle of loose materials. No explanation can be offered for the occurrence of this limited area of high intensity (Grade B) unless it be that the district has been converted into "made" ground by extensive grading in the preparation of the surface for building sites and streets.

At the corner of Vallejo Street and Van Ness Avenue, fissures were formed in the asphalt paving, sidewalk pavements were thrust over the curbing, and water-mains and sewers were broken. Buildings were thrown out of the vertical, and foundations and lower story walls were shifted and crushed. The walls about the foundation of one brick building were actually deformed into undulations with much consequent cracking. This building was so badly damaged that it had to be taken down. Surrounding this corner is a small ovoid district, about 2 blocks in extent, in which the intensity was clearly of Grade B. This was once a sharp ravine and had been filled to a depth of 40 feet in order to provide a



suitable grade for streets and buildings. The filling was shaken together and moved slightly downhill.

On Lombard, between Gough and Octavia Streets, is a little area, less than a block in extent, in which the destructive effects were of Grade B. No particularly notable effects were produced. It is a district of made land, formerly the site of a little lagoon in the sands, known as Washerwoman's Lagoon. A portion of Union Street, between Pierce and Steiner Streets, not more than a quarter of a block in length, where a filling had been made to equalize the street grade, was shaken down into the adjacent building lot on the north. The north sidewalk was shifted about 10 feet to the north, and deprest about 10 feet below its original level. The south sidewalk was deprest a few inches and shifted to the north from 2 to 3 feet. The paving and the cable conduit suffered more severe damage than at any other point in the city. The photograph (plate 88B) conveys a graphic conception of the very great violence which occurred here. The phenomena have no general significance, however, despite their striking character, being merely a sliding of unconsolidated material not supported on the sides. But that such places are dangerous building sites, especially in regions subject to seismic disturbances, is unequivocally demonstrated.

Along the north shore water-front, between Fillmore and Steiner Streets, from Bay Street to the water's edge, was a plot of made ground occupied by a gas-producing plant. Here brick walls were cracked and partly thrown down; part of the wooden framework was wrenched out of position, and the chimney stack was broken. One of the large gas-containers was badly wrecked, but whether its destruction was caused directly or in some secondary way, as by rapid leakage, is not known. The intensity was clearly Grade B.

Along Lyon, Baker, and Broderick Streets, north of North Point Street, is a small locality 2 blocks wide and 4 blocks long, where the Baker Street sewer was broken and frail frame buildings were thrown out of the vertical. This district was partly made land, but the greater part was on the point of a sand-pit. Unquestionably extensive grading had been done to prepare the ground for building.

In Golden Gate Park, near the Museum, the granite railing of a stone-arch bridge was shattered by the shock. This was a low balustrade, with many turned granite posts set closely together, supporting a flat, massive granite top-rail. Such damage as it sustained appears to indicate an intensity of Grade B. The bridge was built on loose sand of no great thickness.

On Fulton Street, between Twelfth and Thirteenth Avenues, there was much slumping of the street-filling down into the Park adjacent; and exactly the same sort of damage occurred on H Street, between Ninth and Fourteenth Avenues. Altho, under the definitions, the damage produced in these localities denotes intensity of Grade B, it is believed that the energy of the shock was not greater than elsewhere in their immediate neighborhoods. They were especially susceptible to damage from earthquake shock, being practically loose earth embankments.

Strawberry Hill, in Golden Gate Park, is a chert knob rising abruptly in the sand wastes. Its summit had been leveled, but it is not known whether this was done by cutting off the top and filling out the upper slopes, or by filling alone. The altitude given for the present hill is the same as that given in the earliest accurate surveys. Much artificial stone work, and a circular concrete observatory building 2 stories high, had been erected upon the leveled hilltop. This building was of weak design, having a row of columns, with windows between, which rested upon a foundation wall 3 feet high and supported a heavy second-story balcony. The construction itself was probably good, but the observatory was utterly ruined by the shock. (Plates 84 and 85.) The entire lower story was sheared out of position, and part of the balcony fell. The cement floor showed numerous cracks arranged in a roughly concentric way.

The whole periphery of the hilltop was broken into a series of concentric blocks or steps, and the outer ones moved down the hill from 2 to 3 feet. The artificial stone work was badly cracked and dislodged. These phenomena indicated that the material used in grading the upper slopes had settled somewhat, with consequent rupture of the surface and wrecking of the building. No other explanation can be urged for such striking damage on this hill, in view of the small damage produced on other rock summits in the city.

All the driveways in the western part of Golden Gate Park showed scattered narrow fissures. There were but few structures here, and they did not show significant damage. These were low, strong, frame buildings. It is a district which was extensively graded in the work of landscape gardening, and is underlain by a deep sand deposit. It appears to have suffered a shock of intensity of the middle range of Grade B.

#### PHENOMENA OF ESPECIAL INTEREST.

About the Ferry Building, at the foot of Market Street, is a district of "made" land, shown on map No. 17, in which high intensity was manifested. Here buildings of all sorts were crowded close together. Wooden buildings, 1 story to 3 stories high, with brick or stone work fronts, were interspersed among ordinary brick buildings from 2 to 6 or 8 stories in height. Mingled with these was a considerable number of modern, class A, office buildings. Here the fire burned fiercely and caused great havoc, heaping the streets and the cellars of buildings with fallen brick and stone and twisted beams and girders. For weeks after the conflagration many of the streets were completely hidden under the débris. So much of the damage due directly to the shock was thereby concealed or obliterated, that no adequate knowledge of the direct effects of the earthquake could be obtained in this part of the city; tho eye-witnesses tell of cornices and gables which fell, and of walls and roofs which collapsed at the time of the shock. After the fire had past, standing walls revealed ugly, sinuous cracks, in rudely parallel systems, which were not due to fire nor to dynamite. Masonry blocks in the walls of excellent modern buildings were broken as by a blow. Rivets were sheared off in parts of the framework of steel structures, and tension rods in such frames were badly stretched. Tubular cast-iron columns, supporting floor girders, were broken off near their bases in cellars where they rested upon piling. The concrete casing of piles was frequently broken. Wherever the intensity was high, the tendency to crack or crush near the base, as tho a sharp blow had been struck there, was notably conspicuous. In spots the streets sank bodily, certainly as much as 2 feet, probably more. Accompanying this depression, concrete basement floors were broken and arched, as if to compensate for it. The surface of the ground was deformed into waves and small open fissures were formed, especially close to the wharves. Buildings on the water side, along East Street, generally slumped seaward, in some cases as much as 2 feet. The damage was greatest close to the water's edge, growing less as the solid land was approached, gradually at first, then more rapidly. These phenomena seem to suggest that the materials used in filling were shaken together so as to occupy less space with the accompanying development of waves, fissures, and structural damage. The more recent the filling, the more it would be compacted; hence the greater prevalence and magnitude of destructive effects near the water's edge.

As well as could be made out from the inadequate evidence left by the fire, the district which suffered intensity of Grade B is limited on the landward side by a line drawn from Filbert Street to Market Street, between Battery and Front Streets; thence between First and Fremont Streets to a little south of Folsom Street, where the line turns and runs eastward to the wharves. Flanking this district on the landward side is a narrow, sinuous area limited by a line drawn from Filbert Street to Green Street, just east of Sansome Street; thence between Sansome and Montgomery Streets to Market Street; thence to the corner of Mission and First Streets; thence between First and Fremont Streets

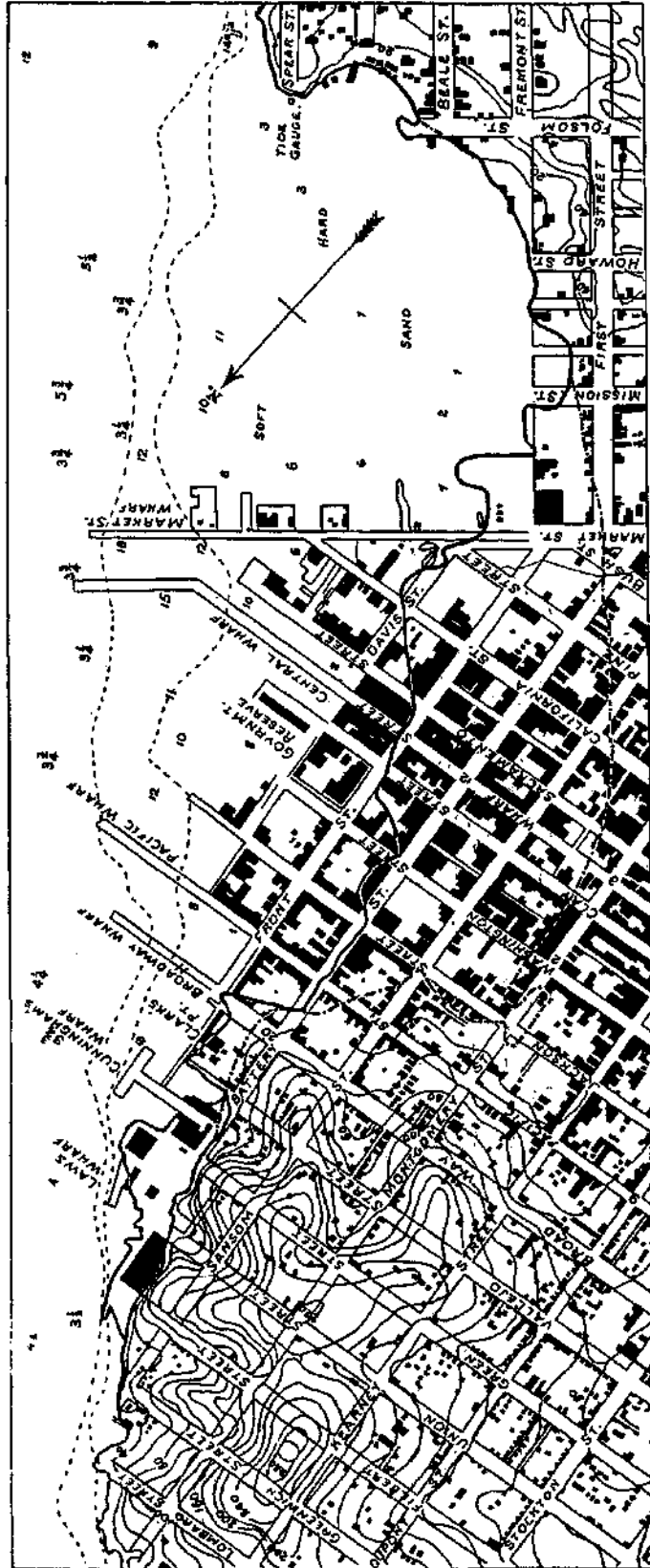

FIG. 51.— Map showing original high-water line of Eddy survey (dot and bar) and mean low-water line or "zero contour" (full line) for district about foot of Market Street in 1853. From Chart of Coast and Geodetic Survey.

to a point south of Folsom Street; thence easterly nearly to the wharves. Between Washington and Sacramento Streets, this boundary is barely east of Montgomery Street. Immediately west of these districts, low intensity prevailed.

It is of interest to inquire whether all or only a portion of this district in which high intensity was developed is "made" land. In the map (fig. 51) is reproduced a portion of the U. S. C. & G. S. chart, "City of San Francisco and its Vicinity," published in 1853 from surveys made in 1851-1852. On it the dot-and-bar line represents the course of the "original high-water line according to plot of Wm. M. Eddy's survey dated 1852." The "zero contour" which determines the configuration of the shore, except where wharves put out, is shown by a continuous line; it is not expressly defined, but it is believed to represent mean low-water, as the soundings are measured from this level. It is needless to point out that this contour is drawn farther seaward than the original high-water line. The portion thus delimited has an area of not less than 20 city blocks, partly or wholly occupied by buildings. Quite outside the "zero contour," as shown on this map, are 8 complete blocks and portions of others — an area of not less than 10 city blocks, partly or wholly built upon. If, then, confidence may be placed in the location of the original high-water line of the Eddy survey of 1852, there were already in San Francisco 30 blocks of "made" land, occupied wholly or in part by buildings before the end of 1853, less than 4 years after the sudden rush to California which followed the discovery of gold in 1849. The revised chart of 1857 shows that very little additional land was made in this district in the succeeding four years.

Without conflicting evidence from other surveys, and no such evidence has been found, the high-water line established by the Eddy survey can not be discredited. Still it is proper to state that these facts raise some doubts as to the accuracy of its delineation, and that the evidence developed by the earthquake does not tend to dispel these doubts. The gradation in the effects produced by the shock, from great magnitude at the waterfront to small at the former land margin, would suggest that at least the marginal district where only Grade C intensity was developed, tho outside the location of the original high-water line, might not be made land, altho it has undoubtedly been somewhat elevated by grading. Very little stress can be laid on this suggestion, however, for these districts suffered very severely in the earthquake shock of 1868; but the materials used in filling were then, of course, shaken together, and in addition, the slow settling together from year to year has undoubtedly compacted the earlier made land much more than that recently "made." Besides, the exhibition of damage depends upon the character of the structures in a given locality, as well as upon the ground, and it is to be noted that the buildings along Kearney, Montgomery, and Sansome Streets comprized a larger percentage of excellent structures than the streets nearer the wharves. The problem is thus complex, and very likely unsolvable; but there remains the haunting suggestion that the "original high-water line" does not constitute the landward boundary of the "made" land, properly speaking. At any rate, it is very clear that that which was known to be "made" land suffered much more severely than that which was known to be natural alluvium.

It is important to recognize that, despite the great intensity manifested near the waterfront, first-class modern buildings, such as the Ferry Building, built upon deep piling or grillage foundations, were not imperiled by injuries to their walls or framework. Some rivets were sheared off; some tension rods were stretched; an occasional girder was dislodged, and cracks were formed here and there in the brick and stone walls. Large financial loss was unquestionably occasioned, but buildings of this type were not in serious danger of collapse nor of being toppled over, either during or after the shock. Nevertheless conservative engineers recognize that even these structures were weakened. They recognize, too, that future shocks may exert greater energy, and they are trying to devise buildings better able to resist the peculiar stresses of earthquake shocks. The

general public should share their interest, and uphold and enforce the provisions they deem it wise to make against future disasters.

A good indication of the value of deep piling as a foundation structure was furnished by the conduits of the cable-car system on lower Market Street. On account of the constant tendency of the whole district to subside from year to year, as the filling material became more closely compacted, these conduits were constructed upon piling to secure permanence of grade. On both sides of them the street sank in places as much as 2 feet, and the pavement was broken, fissured, and thrown into waves. These tracks did not escape entirely, but for several days, before street repairs were made, they constituted a narrow raised path along the center of the street.

Altho in this part of the city the fire did much to conceal the earthquake damage, a few little spots, especially along the water-front, where water was available, escaped its devastation. A building on Spear Street near Folsom, occupied by the National Bolt Works, illustrates what must have occurred in the case of many small brick structures. Its side wall was thrown down and the entire structure lurched out of plumb. To be sure, this building was heavily loaded on its second floor; still it was not so badly damaged as many partly standing walls in near-by districts swept by fire. The earthquake cracks, being sinuous, and recurring with a rude parallelism, were easy to distinguish from cracks opened by heat, or by the stresses induced by the wrenching away of falling walls or by dynamite. Buildings erected upon good foundations withstood the ordeal well, even when the streets around them were deprest and fissured. The Appraisers' Building furnishes a good illustration of this; it is substantially built of brick upon a piling foundation, at the corner of Washington and Sansome Streets, and still stands without significant damage. The levels of its foundation walls were not disturbed. (See fig. 53.)

High intensity was developed thruout a small elongate district having a width of about two blocks, which extends from near the corner of Eighth and Mission Streets to the vicinity of Fourth and Brannan Streets; from this point the boundaries are irregular and very sinuous, leading to the water-front at about the crossings of Third Street with Berry and Channel Streets. A glance at the geological map, No. 17, shows that the regularly bounded portion of this district corresponds very closely with the area of a former tide-marsh, drained and flooded by one or two small tidal streams. The former shore line of Mission Bay was just north of Brannan Street, between Fourth and Fifth Streets, so that the irregular seaward portion of the district lies outside the old shore.

This is one of two localities in the city, the other being a "made" land tract along the former course of Mission Creek, in which destructive effects of great magnitude were conspicuously developed. Only in very close proximity to the fault was greater violence manifested. For blocks the land surface, paved streets, and building plots alike, were thrown into wave forms, trending east and west about parallel to the length of the area. The amplitude and wave-length of these earth billows, and the distances to which they extend, are indefinite and irregular. The fissuring and slumping, and the buckling of block and asphalt pavements into little anticlines and synclines (arches and hollows), accompanied by small open cracks in the earth, characterize the land surface. This slumping movement or flow took place in the direction of the length of the area, and its amount was greatest near the center, or channel, where the street lines were shifted eastward out of their former straight courses, by amounts varying from 3 to 6 feet. A satisfactory photograph of this phenomenon was not obtainable, owing to the quick convergence of parallel lines in perspective, but to the observer in the field it was a very striking result of the shock.

The greater part of the district was occupied by wooden dwellings and shops, with a small percentage of mediocre brick buildings and a few of substantial construction. The fire swept the area clear. Not even heaps of debris remained to cover the ground, most



A. Frame building on west side of Eleventh Avenue, just south of California Street, San Francisco. A weak structure, built on sand. H. O. W.



B. Slip of a fill on Union Street, just west of Steiner Street, San Francisco. H. O. W.



C. Buss Street, between Polk and Howard Streets, San Francisco. Paving blocks forced up into sharp arches and dislodged by compression. H. O. W.



D. Moss Street, between Folsom and Howard Streets, San Francisco. Paving blocks arched by compression along sinuous crest, curbing thrown into an inverted V. H. O. W.



A. Columbia Street, just south of Folsom Street, San Francisco. Slumping, depression, and farrowing of block pavement. H. O. W.

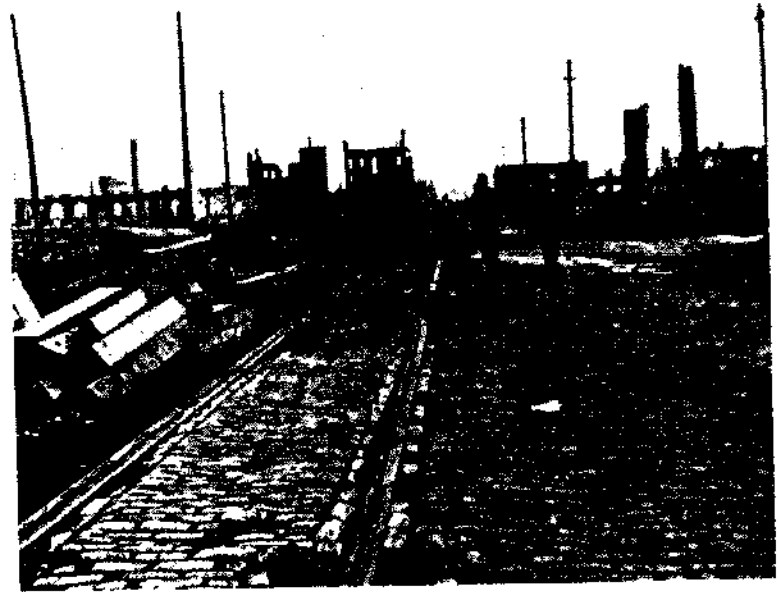

B. Bryant Street, near Fourth Street, San Francisco. Flexure of heavily ballasted car tracks in block pavement; an effect of sharp compression. H. O. W.



C. Sixth Street, near Howard. Once occupied by marsh. Street dropt nearly 3 feet. Sidewalk held up by piling foundation of a building. H. U. W.



D. Looking along Dore Street, from Bryant toward Brannan. Undulating and fractured condition of pavement due to earthquake. Houses thrown off their underpinning and pitched out of the vertical. H. O. W.



A. Looking along Dore Street from Brannan toward Bryant, Larger undulations near Brannan, Dore Street is on site of an arm of Mission Creek. H. O. W.



B. Dore Street, near Brannan, Vertical difference between crest and trough of undulations, 5 feet. H. O. W.

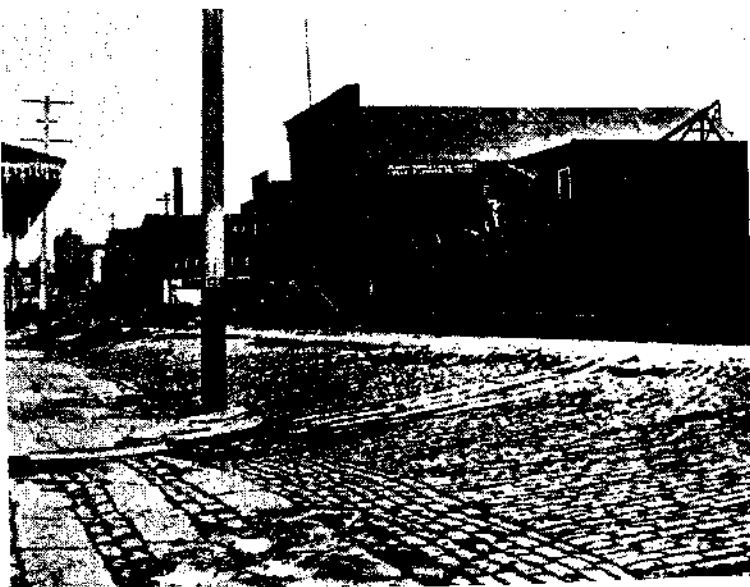

C. Eighteenth Street, just east of Shotwell, Fissuring and depression of Pavement. H. O. W.



D. Southwest corner Portola and Waller Streets. Buildings have shifted down hill slightly, upper parts more than lower. H. O. W.



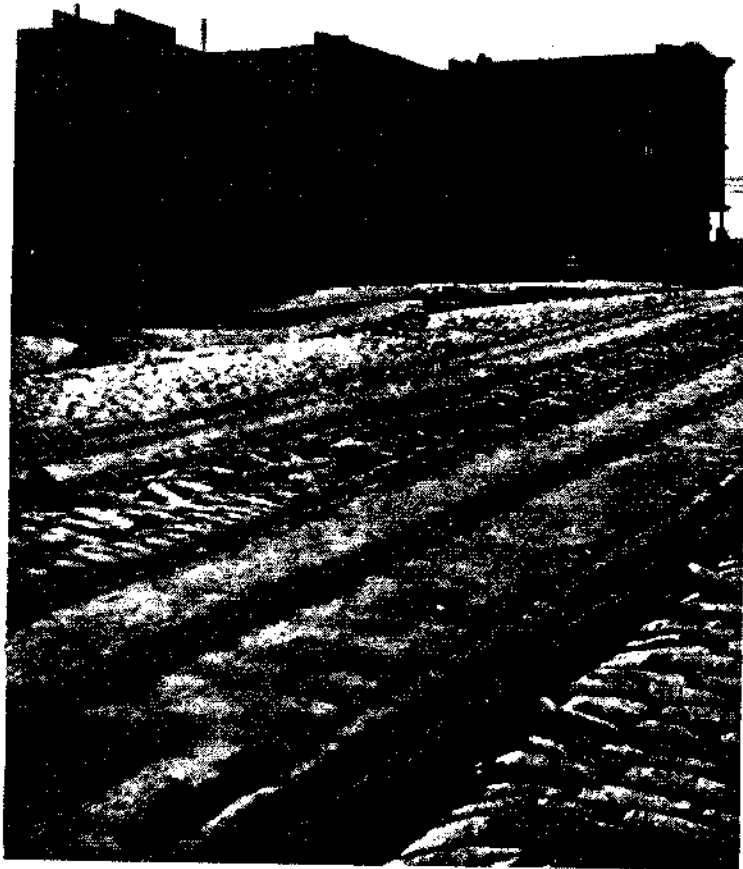

A. Ninth Street, between Bryant and Brannan. Undulation and flssuring of pavement and sidewalks. Houses over trough have been dropt from their underpinning. G. K. G.

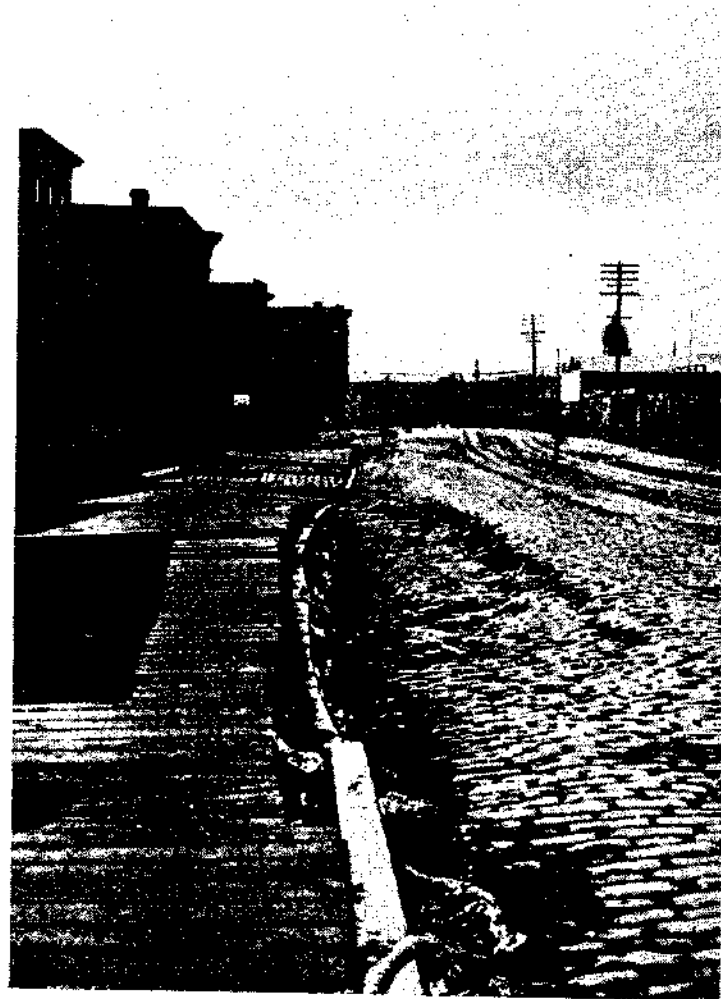

B. Ninth Street, between Bryant and Brannan. Westward lurching of land toward former creek channel where Dore Street now is. G. K. G.

of the destructive effects being obliterated, along with the structures in which they were developed. Enough remained, however. Foundation walls and sidewalk pavements were broken and flexed; sharp little anticlines were produced in the street by the arching of block paving, as on Russ Street between Folsom and Howard Streets (plate 88c); granite curbing was broken and thrust up into an inverted V, as on Moss Street, between Folsom and Howard Streets (plate 88D); there were fissuring and slumping in the block pavement, as along Columbia Street between Folsom and Harrison Streets (plate 89A), and sharp flexures of the paved streets and car tracks, as on Sixth Street just south of Howard Street. These effects point simply and clearly to the great magnitude of the intensity thruout the greater part of this old swampy district.

Attention has already been directed to the slumping or flow movement to the east along the long axis of the area.

The heavily ballasted car-tracks on Bryant Street, at the crossing with Fourth Street, were sharply flexed laterally, tho bounded by block paving. (Plate 89B.) This was at the eastern end of the district where the marsh formerly bent to the south around the flanks of Rincon Hill, a mass of firm sandstone rising from the floor of Mission Valley. No similar sharp flexures were encountered along east-west streets in the western or central portion of the district, tho lateral displacement and flat, sinuous curvings of the street lines were common enough; notably on Harrison Street between Fifth and Sixth Streets, and on Folsom Street between Fourth and Seventh Streets. Both these streets cut across the direction of the flow movement at a small angle. These phenomena are easy to understand if, as seems certain, Rincon Hill served as a solid buttress against which the flow to the east was arrested, causing sharp crumpling of the surface near the buttress, with less disturbance farther away. This was combined with a slight tendency to flow southward in the southeastern part of the district.

The shaking caused the materials used in filling to settle together and occupy less space, so that the surface over the whole district was lowered by amounts varying from a few inches to 3 feet or more. This is clearly seen in the change of street levels along the margin of the solid ground, where the car rails are bent downward in little monoclines. Occasionally a structure with a relatively good foundation remains at its former level, with the whole neighborhood deprest about it. Such a case is exemplified on Sixth Street, a little south of Howard Street, near the margin of the area. (Plate 89c.) The flow movement is thought to be due simply to the action of gravity, the loose, water-soaked material being compacted into less volume by the shaking. Besides this sinking of the district, and its flow movement, mention has been made of the deformation of its surface into irregular waves, trending approximately east and west parallel with the length of the district. Along the streets running approximately north and south, at right angles to the elongation of the area, car rails were bent abruptly to the side, or raised in arches, and sharp anticlines were formed in the block pavements. Large square concrete slabs, used for sidewalk paving, were thrust one over the other; and in one or two cases a slab entirely covered an adjoining one. These phenomena indicate shortening by compression in the north-south direction. On the other hand, however, a stretching of the surface is shown by fissures in the paving; by places where wedge-like blocks were deprest below the general level; and by the rails of car tracks which were pulled apart in amounts varying from 8 to 12 inches. Owing to the relatively great and very variable structural strength of paved streets and heavily ballasted car tracks, these phenomena are not developed regularly nor frequently enough to afford a satisfactory test of the hypothesis that they are directly associated with the wave forms into which the surface of this district was thrown. Besides, owing perhaps to the varying rigidity of the materials which make up the surface of the streets and building plots, the wave forms themselves, tho generally prevalent, are not persistent in their extension. The compression and (listen-

sion effects, however, are believed to be due to the same cause as that which generated the wave forms; for there is no evidence of any true shortening, or lengthening, of the north-south dimension of this district, nor is there any probability of this having occurred.

In addition, then, to the flow movement and the settling together of the loose materials causing depression, there was some sort of rhythmic movement in this loose earth which produced wave forms in the surface, with places of compression and places of stretching. It probably was this movement which was most effective in producing structural damage. It is not believed that these surface waves were traveling waves "frozen" as the shock subsided. If they had been of that character, the ground surface should be more broken than it appeared to be; for in relatively rigid materials such waves must develop open fissures along the crests, which would close with crushing in the troughs. It must be noted, without any attempt at explanation, that the destructive effects of great magnitude which have been described above, are practically confined to the "made" land which occupies the old marsh site.

Southeast of Brannan Street, where formerly lay Mission Bay, such effects are of less magnitude, in general; are less regular in their occurrence and are, on the whole, less prevalent. The complete devastation caused by the fire in this neighborhood leaves little to indicate the actual damage to the buildings wrought by the earthquake. Certain hotels or apartment houses are known to have collapsed, and many fatalities must have occurred. Probably a few dwellings were thrown down. A fairly large percentage of the buildings, one must believe, were rendered dangerous for occupation, even tho not completely thrown down.

The new United States Post-office building (plate 94B), at the corner of Seventh and Mission Streets, was just on the margin of the district. It is a steel and granite structure, resting upon a foundation of piling driven to a considerable depth, but not as far as some had considered advisable. At its southwest corner, the streets are deformed into great waves, some with an amplitude of at least 3 feet, causing fissures and sharp compressional arches in the pavement and sidewalks. Some of the granite flanking structures, which did not rest upon the pile foundation of the building, shared this undulatory movement. In consequence, the building appears badly damaged to the casual observer. It is quite true that the structure was terribly shaken and greatly damaged — such injuries as the destruction of mosaics in the arches of the corridor helped to increase the loss — but the structure was not in peril of collapse, tho one of the low walls had to be supported by timbers. For the most part, the building survived the ordeal, and is in a safe condition for use.

As stated briefly above, a similar district of high intensity occurs in an area of made land along the lower portion of the former course of Mission Creek. This district varies in width from 1 to 2 blocks, extending from near the corner of Ninth and Brannan Streets westward for about 3 blocks, then southwestward for about 2 blocks more; and finally, westward some 4 blocks more to a point on Nineteenth Street just east of Dolores Street.

Mission Creek was formerly a sinuous tidal stream, with narrow fringes of salt marsh about its banks. Near its mouth the stream wound around a rocky point where the serpentine hills of the Potrero rose abruptly from its southern bank. Here, along its margin, is found the most sudden transition from high to low intensity that is anywhere encountered in the city. Along Dore Street, a narrow alley running from Bryant Street to Brannan Street, between Ninth and Tenth Streets, the street pavement was broken into a series of waves. The photographs, plate 89D, looking along Dore Street from Bryant toward Brannan Street; plate 90A, looking from Brannan Street in the reverse direction; and plate 90B, showing in detail the trough of one of these waves, with the fissuring of the pavement near the farther crest, indicate more clearly than words the great intensity manifested here. Less than 2 blocks south on the hill slopes, more than

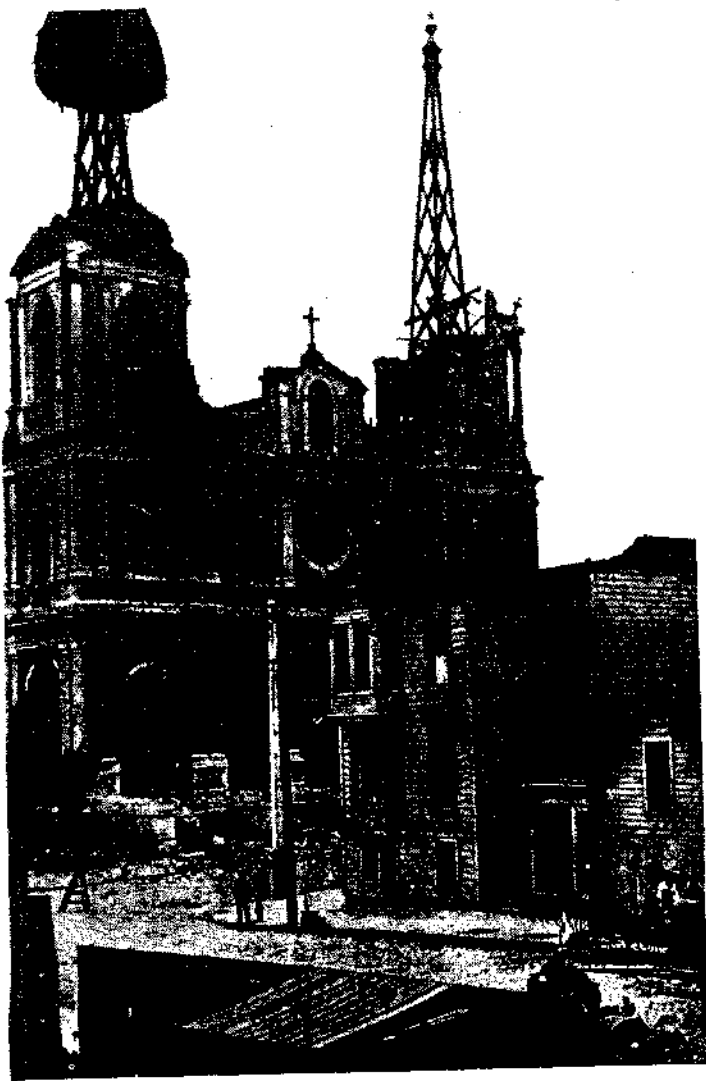

A. St. Dominic's Ochoa, Bush and Steiner Streets. Brick and masonry structure upon sand and alluvium of no great depth. A. O. L.



B. Looking south on Howard Street from near Seventeenth Street. Compression flexure of car rails. G. K. G.

50 per cent of the chimneys were left standing, and no serious structural damage was noted. No comment seems needed to establish clearly the fact that the change in the character of the ground, this being the only variable factor, is in some way the cause of the change in the degree of intensity.

On Ninth Street, east of Dore Street, between Bryant and Brannan Streets, the block pavement was badly damaged by fissuring, slumping, and the formation of surface waves. Frame dwellings were thrown from their underpinning, and a few collapsed. Plate 91A shows a wave trough near Bryant Street, with the resulting disturbance of the pavement. The dwellings immediately in the trough have dropt from their foundation posts. In plate 91B, looking along Ninth Street from near Brannan Street, is shown the depression and fissuring of the street and its slumping or flow westward toward the former channel of a short branch of Mission Creek, which occupied the present location of Dore Street. Streets, curbing, car tracks, etc., are deflected from 6 to 8 feet from their former positions. The frame dwellings were not destroyed, but a careful examination of the picture will show that most of them are badly injured. Many were left in a dangerous condition by the shock.

On Tenth Street, between Bryant and Brannan Streets, less violence was noted and the slumping of flow eastward (toward the channel of the little branch of Mission Creek) is scarcely noticeable.

Again, along the creek bed from Folsom Street, between Seventeenth and Eighteenth Streets, to the vicinity of Valencia Street at Eighteenth, great destruction was conspicuously prevalent. Less than a third of the frame dwellings in this tract retained their vertical positions, and a few collapsed completely. Others remained standing only by leaning against each other. The south side of Howard Street, between Seventeenth and Eighteenth Streets, which escaped the fire, furnishes a good illustration of the damage produced here. (See plate 93A.) AS in other places, the streets were deprest, fissured, and thrown into waves. (Plate 90c.) Car rails were arched and bent laterally in a violent fashion. (Plate 92B.)

Sewers and water-mains were broken. At Eighteenth and Valencia Streets there was a serious break in the water-pipe. Here, on both sides of the street, the ground sank about 6 feet, causing the roadway to arch in a very noticeable way. (Plate 93B.) Ten-inch car rails were bowed up into arches from 24 to 30 inches in height. The Valencia Street Hotel collapsed so that occupants of the fourth story could step out into the street. Casualties in this district can never be known accurately, owing to the immediate onset of the fire, and the complete devastation it produced.

On land made by filling in, "The Willows," a marshy tract formerly extending up the Eighteenth Street Valley from Mission Lagoon, near the corner of Nineteenth and Guerrero Streets, there was observed a considerable slumping or flow movement of the surface. The photograph (plate 94A) shows the Youth's Directory, a charitable institution for boys, where the street and building were moved northward and slightly eastward, toward the former channel and downstream, fully 6 feet.

Enough evidence has been cited to demonstrate that high intensity prevailed thruout this district. Here, as in the other tract of made land which occupies the site of the old tidal marsh, the materials used for filling were shaken together, and caused a general depression of the surface over the whole district, accompanied by slumping or flow movements. The surface was deformed into waves, with accompanying fissures and sharp compressional arches. Hero too, as in the tract previously described, the materials used for filling constitute a relatively thin rigid layer deposited upon the marshy fringes or in the shallow waters of the creek.

The creek (see map No. 17) formerly extended for about 2 blocks eastward from Ninth and Brannan Streets before it reached the old shore line of Mission Bay. This portion

of its course is now occupied in large part by the railway tracks and structures of the Southern Pacific Company; and the exceptionally strong foundation necessarily provided for the railway line probably explains why less damage was found here than one would at first have expected. At any rate, the greatest damage noted was the cracking of brick walls and the falling of cornices.

The space formerly occupied by Mission Bay has been partly filled to provide building sites, and of course the materials used in filling were deposited in water. The district is occupied in part by structures of great strength, such as railway tracks; in part it is devoid of buildings. Thruout the district, evidence was insufficient and inconclusive. Except near the former outlet of Mission Creek, and in the area further north formerly occupied by the tidal marsh, the destruction produced does not denote intensity higher than Grade C. Apparently, therefore, land made by filling up spaces of open water is less dangerous, on the whole, than land made by depositing a thin rigid layer of filling upon a tract of marsh land. This, at least, is the lesson in San Francisco. The reasons for it are not very clear. Space forbids a discussion of theories which can not be adequately tested. It may be noted, however, that much of the material used in filling in areas of water has been broken rock derived from the grading down of neighboring rocky hills.

Near the corner of "Waller and Portola Streets, not far north of the head of Market Street, is a locality, less than a block in extent, where houses were shifted slightly on their foundations; their upper stories were moved farther eastward (downhill) than the foundations, as a result of shearing in the framework of the basement or of the first story of the buildings. (Plate 90D.) There also occurred minor bucklings and breaking of the thin asphalt pavement. The intensity, which belongs low in the range of Grade B, diminishes rapidly in all directions, and the district is surrounded by a band where the intensity is Grade C. Here a thin layer of sand reposes upon the slopes of a little upland valley between the low serpentine hills to the east and the high chert hills to the west. The effects are such as would be produced by a shaking downhill of this thin sand layer, with the structures which rest upon it. This seems the best explanation of high intensity in this district. Attention, nevertheless, must be directed to the fact that this, and three other districts shown on the map, No. 19, lie roughly along a straight line which nearly coincides with the western boundary of the serpentine body. At its northwest end, this boundary is known to be determined by a fault of considerable throw, constituting consequently a weak place in the crust of the earth here. It is not known how far southeast the fault extends, and it is not unlikely that it cuts entirely across the peninsula. The recurrence of these little districts of comparatively high intensity suggests that it continues as far south as Market Street, at least, and that such a zone of weakness was especially suited to the production of high intensity by the shock. This hypothesis can not be conclusively tested, but it is interesting and important enough to merit presentation and to receive attention in the event of future earthquakes.

In support of the statement made in the foregoing pages that the intensity increases markedly as one approaches the fault, independently of the character of the ground and other factors, the following evidence is presented:

Forty-eighth Avenue, between K and N Streets, is a district underlain by deep sand where extensive grading operations were undoubtedly necessary to convert an area of sand-dunes into streets and building lots. Here small, substantial frame dwellings were shifted bodily from 1 to 2 feet out of position, and the streets were slightly dislocated. Telegraph poles were thrown down or caused to lean over so much that only the tension of the wires kept them from falling completely, and lamp posts were overthrown. The dwellings suffered little structural damage, owing to their small, substantial character, and to their being built close to the ground; so that when shifted from their underpin-



A. East side of Howard Street, between Seventeenth and Eighteenth Streets. A. O. L.

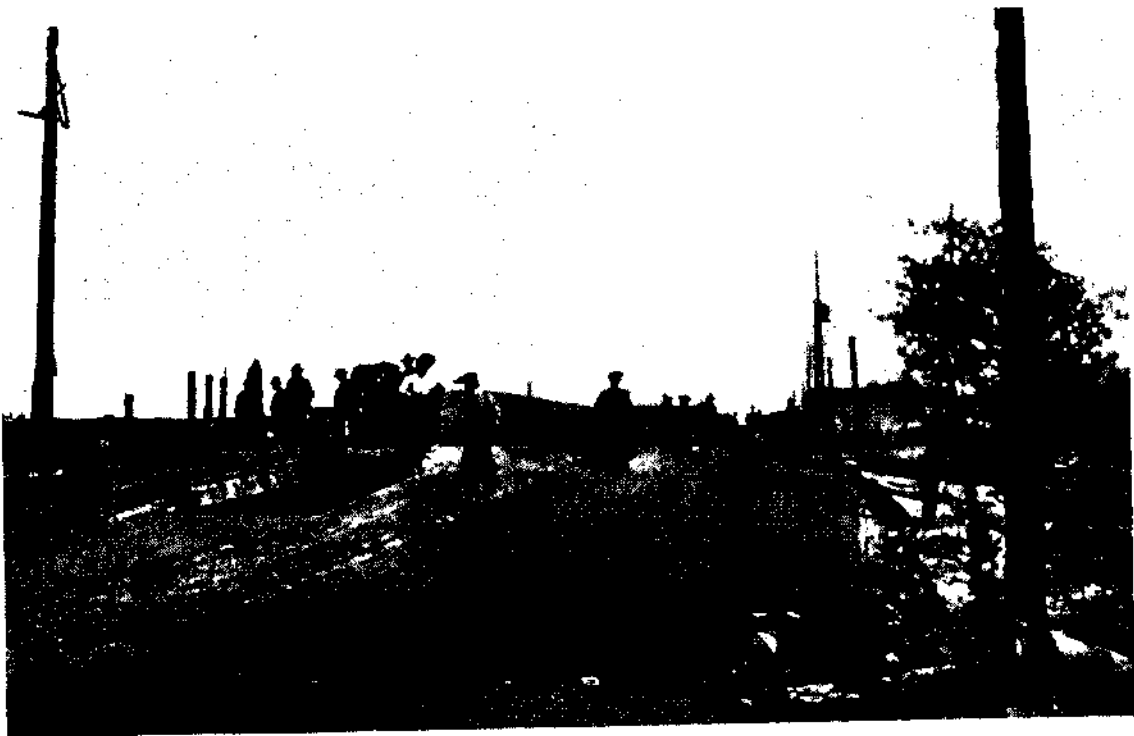

B. Valencia Street, near Eighteenth. Sinkhole in neighborhood sunk about 8 feet, blocking street into\* A.O.L.



A. View along Nineteenth Street, from Guerrero Street. Both ground and buildings moved north about 6 feet toward center of old marsh, with component of movement down the channel. A. O. L.

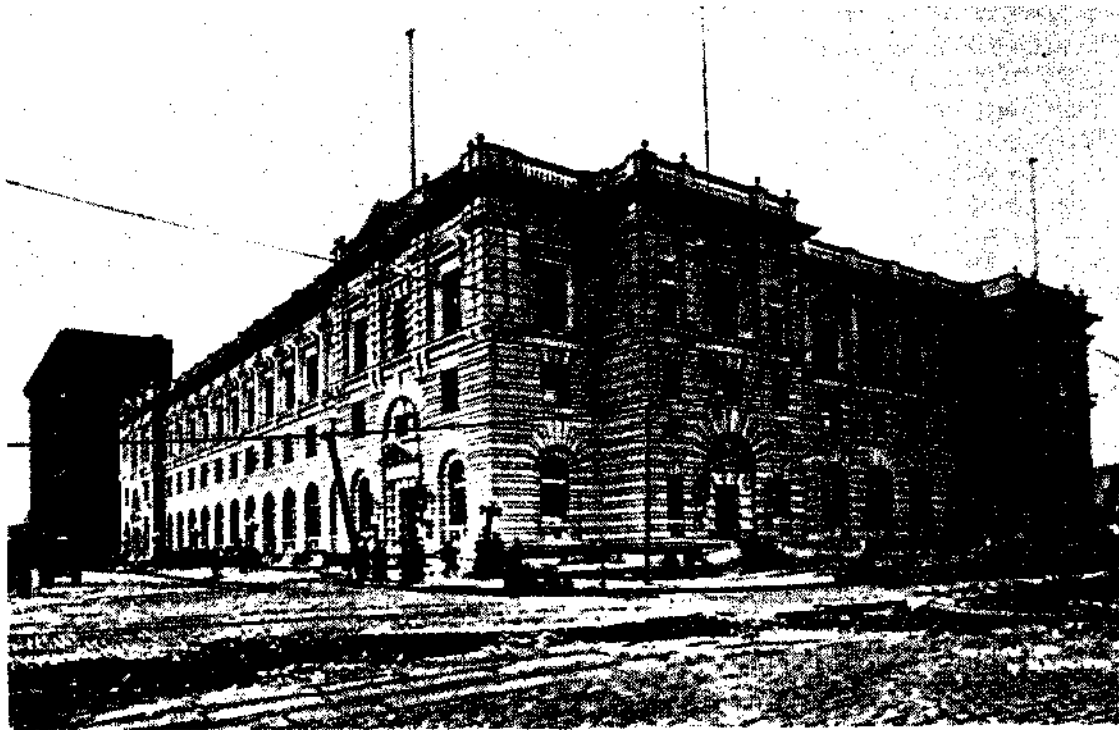

B. San Francisco Post-office, Mission and Seventh Streets. Rear corner of building is on edge of old marsh. Ground over marsh sank and intruded. W. E. Wordsworth, Photo.



ning, they had but a few inches to fall. Still, it is the opinion of the writer that the intensity developed here was little, if any, short of the maximum on the made land in the city, tho the conditions were not such as to permit so great damage.

On Ocean Avenue and X Street, near where the former outlet of Lake Merced flowed, fissures were developed in the street and in the sands on either side, and water was squeezed out so as partly to flood the roadway. Drain pipes were unearthed and bent or twisted.

From the former outlet of Lake Merced, where W Street meets the Grand Ocean Boulevard, or Great Highway, southward along the ocean, low cliffs of soft rock — the Merced sandstones and shales — rise abruptly from the beach. These mount gradually as we go southward, until at Mussel Rock they attain a height of 500 feet. AH along this line of cliffs, and for a short undetermined distance inland, the rock masses were cracked, broken, and traversed by narrow fissures. These effects grow more and more numerous and of greater and greater magnitude until, a short distance north of Mussel Rock, the fault is reached. A short distance south of X Street, a small, substantial frame dwelling, built upon a good foundation under the cliffs by the beach, was almost overturned. South of this there were no structures along the beach except the seaward end of the Lake Merced Tunnel, an hydraulic arch which was slightly broken, tho embedded in the rocks of the Merced formation. All along the faces of these cliffs, much material fell or slid down to the beach.

#### CONCLUSIONS.

This investigation has clearly demonstrated that the amount of damage produced by the earthquake of April 18 in different parts of the city and county of San Francisco depended chiefly upon the geological character of the ground. Where the surface was of solid rock, the shock produced little damage; whereas upon made land great violence was manifested. Other things being equal, there was a decrease of intensity from the southwest toward the northeast, as the distance from the zone of faulting increased. Other conditions, however, exerted a controlling influence. There was, for instance, much greater contrast, in the destructive effects produced, between the summit of Telegraph Hill and the vicinity of the Ferry Building, about a quarter of a mile apart and at practically the same distance from the fault, than there was between the damage produced near the Ferry Building and along the trace of the fault itself. (Consult the intensity map and profiles.) In this part of the zone of destruction, change in distance from the fault clearly did not influence the gradation in intensity, so much as did change in the character of the ground.

#### ADDENDA.

*Subsidence of made land.*—The unstable character of the made land on the waterfront of San Francisco has long been known. This instability made itself manifest in a progressive subsidence which, in the course of years, rendered it quite difficult to maintain the grade of the streets. An effort was made by Mr. G. E. Grunsky, when he was city engineer, to determine the rate of this subsidence, and the following extract from his report as city engineer for the year 1902-3 is not without interest in connection with the violent disturbance of the ground caused by the earthquake in the areas of made land:

Examination has again been made to determine the amount of sinking in those improved portions of the city where subsidence has heretofore been observed. The result of this examination appears from the following table, in which is also given the subsidence which occurred during the preceding year.

Street.	From—	To—	SUBSIDENCE IN FEET.			
			April, 1901, to April, 1902.		April, 1902, to April, 1903.	
			Max.	Mean.	Max.	Mean.
1. Davis. . . .	Market . . .	East . . . .	.07	.05	.08	
2. Jackson . . .	Montgomery	East . . . .	.07	.03	.06	
3. Spear. . . .	Market . . .	Bryant . . .	.10	.06	.05	
4. Mission . . .	First. . . .	East . . . .	.11	.07	.05	.02
5. Harrison (a)	Fourth . . .	Seventh . . .	.17	.15	.22	.19
6. Sixth . . . .	Howard . . .	Channel . . .	.10	.05	.17	.08* •05§

(a) Location of maximum subsidence on Harrison Street between Fourth and Seventh is the same for both years.

\* Mean subsidence from Brannan southerly.

§ Mean subsidence from Brannan to Howard.

1. No appreciable subsidence (Apr. 1902-Apr. 1903) except at Vallejo Street, where maximum occurs.
2. No appreciable subsidence (Apr. 1902-Apr. 1903) except at Drumm and East Streets, where maximum occurs.
3. No appreciable subsidence (Apr. 1902-Apr. 1903) except at Mission Street, where maximum occurs.
4. Subsidence (Apr. 1902-Apr. 1903) occurs from Main easterly; maximum at East Street.
5. Subsidence (Apr. 1902-Apr. 1903) occurs from a point between Fourth and Fifth Streets, as far west as Sixth Street.
6. Maximum (Apr. 1902-Apr. 1903) at Folsom Street.

*Possible premonitory movements* (Miss H. C. Lillis). — Mr. McConnell, a jeweler, located on Post Street between Montgomery and Kearney Streets, states that 4 days before the earthquake he found one of his windows broken in nearly 50 pieces tho none of the pieces had fallen out; and supposing that some one had tried to enter his shop, he sent for a detective. Captain Calunden came, and on looking over the premises declared that it was not the work of a burglar but was due to the settling of the building. He found the building out of plumb. This would indicate a settling of the ground before the shock. One of his workmen who lived in the Mission found his cellar door closed so that difficulty was experienced in opening it. This occurred the same day as that on which the glass was broken.

*Effect of the shock near the beach* (W. D. Valentine). — We were residing on Forty-eighth Avenue, between K and L Streets, within a few hundred feet of the ocean, about 0.5 mile south of the park. In our section the shock was violent. It awakened me instantly, and for a few seconds I was unable to rise, as I was thrown back in the effort. Meanwhile I was carefully watching the movements of an extremely tall and heavy oaken wardrobe which stood almost in the middle of the floor. The top first swung to the west, then to the north, then to the east, and fell directly to the south with such force that it went to pieces. Our heavy upright piano and various heavy articles of furniture were thrown completely over. The sand in our basement raised from 1 foot to 15 inches. A wide and long 3-foot depression was raised level. Our lot, which was 120 feet deep, was shortened at least a foot, which was shown by the folding of the fence. Electric-light poles in the street in front of us, which were in the sand, were thrown down north, east, south, and west. There was a fissure for about a block, between Forty-seventh and Forty-eighth Avenues, about 3 feet wide and 0 or 8 inches deep,

which was of course in the sand. There were also other blow-holes in the sand, which emitted water and sulfurous odors.

*Effect of the shock on the gas plant and pipes* (E. C. Jones). — The earthquake movement was apparently from north to south, inferred from the fact that bookcases and china closets placed east and west were almost invariably tipped over, or their contents thrown out; while those placed north and south were in most cases undisturbed. Gas-mains in streets running east and west were broken and drawn apart, while those in streets running north and south were crushed together and telescoped, or else raised out of the ground in inverted Vs. This rule applied generally, with but few exceptions.

On Jackson Street, between Drumm and Davis Streets, which is made land, the street main was laid on a line of piles which went to hard pan. The piles were not purposely driven to sustain the pipe, but happened to be in the line of the main when it was laid. This pipe broke over the center of each pile, 9 in number, and was not broken in the made ground where it was unsupported.

During the latter part of the first shock, there was a rotating motion which had the effect of twisting gas-holders out of their guide frames.

The foreman of the North Beach Station was looking at the 2,000,000-foot storage holder, and described it as follows:

On going to the window, I looked at the storage holder, which was vibrating like an inverted pendulum, and waves of water were coming over the wall of the tank. The relief holder was similarly affected with water and tar coming over the tank wall. The shrubbery in the garden was shaken as though by a strong wind.

These two holders were heavily framed with latticed girders, and did not leave their guides by the rotating movement of the earthquake.

The storage holder at the Pacific Gas Improvement Company's Works was twisted around 2 feet from the guide rails, while at Martin Station the 1,500,000-foot storage holder was twisted 5 feet on the lower section, 8 feet on the middle section, and 12 feet on the upper section. At this plant the 4,000,000-foot generator was moved bodily 2.5 inches to the south. All connections were of steel, and no joints were broken.

A barn at the North Beach Station, corner of Laguna and Bay Streets, was resting upon wooden uprights about 16 inches high. These uprights were tipped over, and the barn moved the length of the uprights toward the south; that is, after the earthquake it stood 16 inches on the sidewalk.

The buildings at the different plants did not suffer according to their relative strength. Some brick buildings of comparatively poor construction were unharmed. Other buildings of great strength, with heavy footings on good foundations, were shaken to the ground, particularly those running east and west; while buildings of the same or less strength, with foundations not so good, but running in a direction north and south, were but little injured.

*Effect on certain street railways* (T. Mallally). — There does not seem to have been any actual shortening of the length of the street railways of the United Railroads of San Francisco; but the rails in one location traveled about 3 feet in a northerly direction. This location was in the valley and was marsh land, beginning at a point about 100 yards north of Holy Cross Cemetery, where the rails parted, and ending about 1,000 yards north of Holy Cross, where the rails buckled up in the air. We had to cut out about 3 feet at this point, and add 3 feet where it parted at the other end. Of course there was a decided movement of the rails all along, in a lateral direction, which left the tracks out of alignment, but was not enough to prevent operation of cars.

This condition would indicate that the fill in the marsh land moved in a northerly direction about 3 feet, but that the actual distance along our line has not been appreciably changed.

*Deformation of the U. S. Government buildings.* — For the purpose of determining the extent of the deformation of the three U. S. Government buildings — the new Post-office, the Appraisers' Building, and the Mint — the Coast and Geodetic Survey, at the request of the Commission, determined on July 12, 1906, the relative levels of the four corners of each of these structures, as indicated in the accompanying notes and figures. The leveling was done by Mr. C. H. Sinclair. The memorandum of Mr. Sinclair's results, which was placed at the disposal of the Commission by the Superintendent of the Coast and Geodetic Survey, is as follows:

*New Post-office.* — Fig. 52 shows by numbers the positions of the stations occupied; and the points at the corners, the relative levels of which were determined, are indicated by their orientation.

The southwest corner is the lowest and is the only one that settled materially, being about 0.393 foot = 4.72 inches lower. The outer walls have cracks in many places. This is a fairly good showing for a bad foundation.

Sights nearly equal except at II, where backsight is about 100 feet and foresight is about 300 feet. Street so low that readings could not be made any other way. Cars and drays passing all the time. Wind bad. Rod held on circular molding (tower, | circle section) which was the lowest projection built into the wall that was common to the four extreme corners.

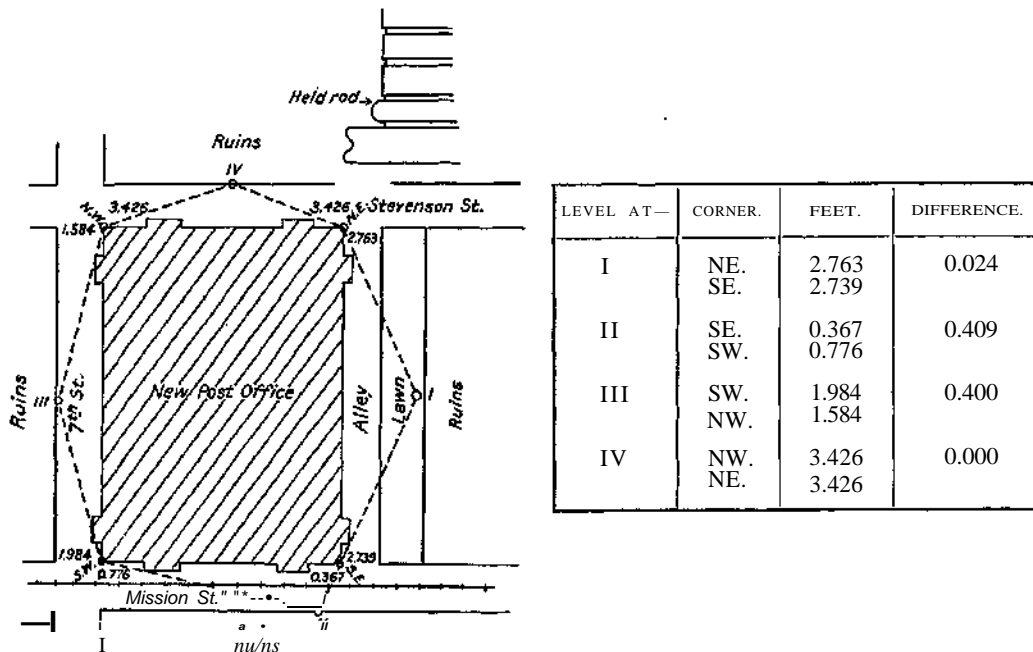

FIG. 52. — Map showing relative levels of four corners of new Post-office, San Francisco.

*Apjtraier's' Building.* — Fig. 53 shows by numbers the position of the stations occupied; and the points at the corners are indicated, as before, by their orientation.

The northwest corner is 0.909 foot = 10.908 inches above the southwest corner. The northeast corner is 0.909 foot + 0.054 = 0.963 foot = 11.556 inches above the southwest corner. The southeast corner is 0.080 foot = 0.90 inch above the southwest corner. The rod was held on top of water-table at each of the four corners, and the sights were nearly equal in length. The south side of the building is about 11.23 inches lower than the north side.

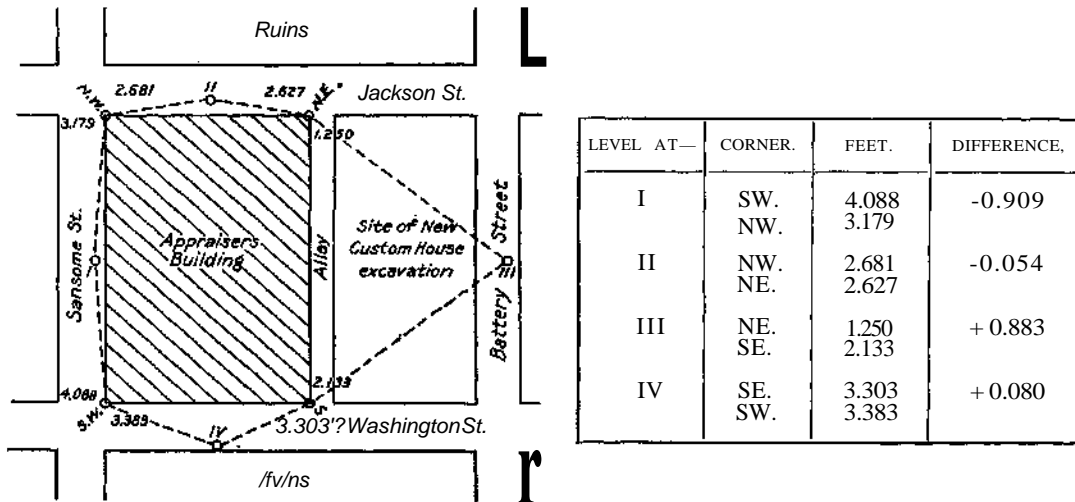

FIG. 53.—Map showing relative levels of four corners of Appraisers' Building, San Francisco.

*Mint.* — Fig. 54 shows by number, as in the former cases, the positions of the stations occupied and the points at the corners are indicated by their orientation.

The southwest corner is the lowest, being 0.498 foot= 5.976 inches (mean) below the northwest corner. The walls on the north side are badly scaled by the heat. No serious cracks were noticed in the outside. The rod was held on top of the water-table at each extreme corner of the building. Street cars constantly passing on both Mission and Fifth Streets, also heavy drays. The wind was very troublesome. Sights were nearly equal.

The deformation indicated by the above measurements can not be wholly referred to the earthquake, since it is quite probable that the structures had settled somewhat before that event. It appears, however, to be desirable to put the measurements on record for future reference.

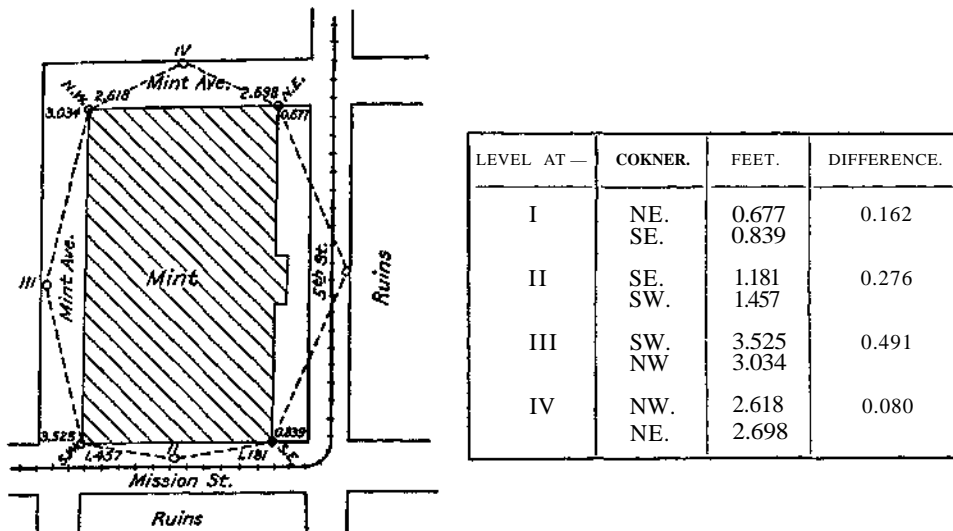

FIG. 54.—Map showing relative levels of four corners of Mint, San Francisco.

### THE SAN FRANCISCO PENINSULA.

BY ROD BRIC CR AND ALL.

The distribution of intensity in the San Francisco Peninsula, south of the city, was studied by Mr. Roderic Crandall, under the direction of Prof. J. C. Branner. The following is Mr. Crandall's report on that territory:

For a consideration of the detailed effects of the earthquake thru the area of the San Francisco Peninsula, it will be convenient to divide the country into two portions along the San Andreas fault, and to subdivide the area northeast of that line into two parts; namely, the San Mateo district, and the Merced Valley.

#### THE SAN MATEO DISTRICT.

The towns of San Carlos, Belmont, San Mateo, Burlingame, Millbrae, and San Bruno are included in the San Mateo district. These towns all lie along the railroad between San Jose and San Francisco, and are in almost a straight line; that is, parallel to and at a distance of from 2 to 4 miles from the San Andreas fault. They are all situated about the same geologically, being upon the Santa Clara Valley floor just at the east edge of the foot-hills of the Santa Cruz range.

*San Carlos.* — The railway station at San Carlos, a low 1-story stone building, was badly damaged, some of the walls being partly thrown down, and the rest of the building cracked. A large frame house near the station was shaken from its cement foundations, and the foundation itself was badly cracked.

*Belmont.* — Between San Carlos and Belmont, over four-fifths of the houses lost their chimneys, but no buildings were thrown from their foundations. At Belmont a majority of the chimneys fell. Reid's school and other buildings in the neighborhood of Belmont sustained similar damages. Reid's school is one mile nearer the fault-zone than Belmont, among the low foot-hills. Thru the hills west of Belmont no cracks nor big landslides were found, but there were small landslides along the road leading from Belmont to Crystal Springs Lake. A tall stand-pipe on the hill southwest of Belmont was unaffected, but it is a well-built structure, guyed with wire cables, and might sway without falling. Near Homestead, in the foot-hills between Belmont and San Mateo, the brick building of the Crocker Orphanage was completely ruined.

*San Mateo.* — San Mateo showed the intensity of the earthquake plainly.<sup>1</sup> Almost all brick and cement buildings were damaged and several were completely ruined. (See plates 98A, B, and 99A, B.) Many wooden structures suffered by being thrown from their foundations, while others were shifted without material damage. Nearly every brick chimney in town was shaken down, with consequent damage to the houses.

At San Mateo Point, which is on the shore of San Francisco Bay, east of the town, low frame buildings were uninjured. Tanks 5 feet deep and 4 feet wide, which were half full of water, were almost emptied by the shock, the water spilling to the southwest. The alluvial flats around the point showed some small cracks, and there was a slight sinking of the ground near the bay.

According to the man at the boat-house at San Mateo Point, the waters of the bay were quieted by the shock. Another man, who was in a boat at the time, felt the shock but not very strongly. Several fairly heavy shocks about 0 o'clock that morning were not felt at all by men on the waters of the bay. At a lumber yard, about half a mile west of the point, part of the wharf was broken, lumber piles were overturned, and a chimney foil.

<sup>1</sup> See Robert Anderson V paper on San Mateo\* and Burlingame in a later part of this report for statistical details.

*Burlingame.* — Along the line of the electric railway from San Mateo northward, many of the poles were left out of a vertical position, most of them leaning toward the northeast. At the Brewer School, in the foot-hills, about due west of San Mateo, little damage was done. A tall, well-built tank-house remained standing, tho the roof built over it, a slight, flimsy structure, was turned thru an angle of approximately  $30^\circ$ , but remained on top.

Tho there were no large brick buildings, many of the houses in the vicinity of Burlingame were badly wrecked, due to the falling of extra heavy chimneys thru the roofs. Brick walls generally fell, unless low and especially well built.

*Millbrae.* — At Millbrae there are but few buildings that could be affected by the shock, but the brick power-house of the San Mateo electric line was partly wrecked. The north and south walls fell, while the east and west ones remained standing. The latter stood because they were held by the steel trusses which spanned east and west.

In the vicinity of Millbrae and San Bruno, it was found that several of the small creeks were well filled with debris of various kinds that had been brought down by an unusual flow of water following the shock, and several days after the earthquake the streams were still carrying a small amount of water.

*San Bruno.* — Near San Bruno, where the county road crosses a small stream, there were numerous cracks in the ground from 3 to 10 inches wide, parallel to the line of the road, which is N.  $25^\circ$  W. The road at this place was built 8 feet above the mud flats, so that these cracks are accounted for by the settling of the fill. There are not many houses in the vicinity of San Bruno Station by which to judge of the intensity, but in the few houses seen the chimneys had all fallen. The race-track buildings at Tanforan, north of San Bruno, were not materially damaged, altho the buildings and bleachers are flimsy wooden structures. Plate 97c illustrates the effect of the shock upon the track of the electric railway on the marsh west of San Bruno.

#### THE MERCED VALLEY DISTRICT.

The Merced Valley district includes not only the valley proper, but also the area covered by the main body of the Merced sediments, from the San Andreas fault-line, east by Baden to South San Francisco and along the southwest face of the San Bruno Mountain, and by the cemeteries to the Life Saving Station on the coast north of Lake Merced.

*Baden.* — Baden, at the south end of the Merced Valley, consists of only a few houses, none of which shows marked effects of the earthquake. The track of the electric tramway line, just south of Baden, shows evidence of intense disturbance. (See Plate 97D.) The roadbed which was built up nearly all the way here was cracked parallel to the rails. One crack varied from 2 inches to a foot in width, and extended about 1,000 feet along the filled-in roadbed. For this distance the double tracks were twisted back and forth in a zig-zag fashion, and up and down to some extent. One rail was bent 2 feet horizontally and 10 inches vertically. Not a single rail in this 1,000 feet remained straight or in place, but in no case were the rails detached from the ties. Most of the poles supporting the electric wires were thrown out of line. The ties were shoved back and forth and from side to side, leaving clean, bare places where they had slid about.

The tracks of the Southern Pacific Railway line, which are parallel to the electric road in the vicinity of Baden Station, were slightly disturbed but not so badly that trains could not run over them. The Southern Pacific roadbed is much better ballasted than the electric line, because it is older and has become more firmly packed, which is the reason that it was not disturbed like that of the electric line. This disturbed portion of the electric line continues about 200 feet north of a road by the Baden Station, until a cut is reached where filling up was no longer necessary. The cracks were thus confined to the filled ground.

Just east of the station at Baden, where a creek crosses the county road, there were cracks in the filled soil, and there was also evidence that in this low ground the creek had flooded a distance of 100 feet on both sides of its usual course. At the time of the first visit, about 3 days after the shock, there was more water in the creek than there had been the previous week. At this same place, a steel water-main, supported on trestle-work, was wrenched so that it leaked badly.

At Big Frawley Canyon a trestle carrying a 30-inch water-main was demolished. (See plate 100A.)

The electric-car line that runs to South San Francisco turns a right angle at Baden, from northwest to northeast. The rails northwest and those northeast of the turn were both badly bent. On the northeast branch the rails were bent into a U-shape, the base of the U being to the northwest with a side thrust of about 2.5 feet. The rails on the northwest end of the line were bent into a V, with the base of the V pointing northeast, the lateral displacement being about 1.5 feet. These are about 60-lb. rails, and at the V-shaped bend mentioned the rails were broken in three places.

*South San Francisco.* — 1.5 miles east of Baden, at South San Francisco, the intensity was considerably lower than at the previously mentioned places. Many chimneys fell, but no badly wrecked houses were seen. At this place the corner fell from a new brick building, under process of construction, and some of the other large brick buildings were slightly cracked. The damage at South San Francisco was not large, taken as a whole. (See plate 97B.)

A little more than a mile east of the town, there are several tall brick stacks, none of which fell. Some were entirely uninjured and others slightly cracked, but only one, so far as known, was badly enough damaged to require rebuilding. The brick structures and stacks at the packing house did not suffer materially.

Some of these buildings are almost on the San Bruno fault-line, and none of them are far from it, so that if there had been any movement along that line, these would certainly have suffered more.

South San Francisco and the meat packers' establishments are on a different geological foundation from the towns previously mentioned. These places rest almost directly upon the old Franciscan rocks, with only a thin layer of sand on top of them in places. This makes a much firmer foundation than is found at the other places, which are situated upon a considerable thickness of sand or gravel.

The buckling of the tracks of the South San Francisco car line between the town and San Bruno Point, where the chimneys mentioned are located, is significant of the contrast in the intensity of the shock at the two places. The rails are bent and broken in a number of places, where the track crosses the marsh between the two places. The difference of intensity is striking when it is taken into consideration how close they are together.

From South San Francisco to San Bruno, there is a line of big steel water-mains, supported on a trestle frame, where it crosses the marsh. This line did not break, but was bent and twisted into S-shaped figures.

North of San Bruno Point, at the Southern Pacific tunnel along the bay shore cut-off, no damage was done, except for the sliding and settling of the debris in the newly filled area.

*The cemeteries.* — The San Bruno fault-line was followed all the way from South San Francisco to the cemeteries. There was absolutely nothing to indicate any movement along that line at the time of the earthquake.

The cemeteries between Baden and Colma suffered very severely from the shock. It was estimated that in Holy Cross Cemetery (plate 96B) over 75 per cent of all the monuments were either thrown down or twisted on their bases. Plate 97A shows a typical



case of a monument overthrown. In a few cases monuments were snapped off. In one instance a single piece about 3 inches thick was broken off by the shock. The upper part of the slab is in two pieces, tho the second break may have been made when the slab fell. The stone chapels at several cemeteries were badly shaken and partially wrecked.

There is one monument in Holy Cross Cemetery that was composed of several pieces, the top piece being the figure of an angel. Underneath this angel was a small thin piece of stone beveled to meet the base of the figure, and below that was a block of about 20 inches square and 12 inches thick. It was observed that the washer and the square block were inverted in their positions. It is stated that this displacement and inversion of these blocks was effected by the earthquake. If so, there must have been enough upward motion to throw this block and washer high enough to turn completely over.

There was no consistency apparent in the direction in which monuments fell; they seem to have fallen in every direction.

The other cemeteries all suffered about the same, but the percentage of fallen monuments was not nearly so high in the others as it was in the Holy Cross Cemetery. The reason for this difference in the number of monuments overthrown is not apparent; the soil of all these cemeteries is practically the same. A possible reason is that the difference in effects is due to a difference in the depth of the sand upon the underlying rock floor, and that there was a greater depth of sand underneath the Holy Cross Cemetery. There is no proof of this, however.

Plate 95A and B illustrates the wreck of buildings at the Woodlawn and Hills of Eternity Cemeteries.

On top of the gate posts at Holy Cross, there were two large ornamental stone balls. These were fastened to the posts by steel rods projecting up into them; these rods, however, did not hold them in place and the balls were both thrown down. West of the gates the stone railroad station was badly wrecked, fully one-third of it being shaken down. Between the depot and the gates small 1-inch water-pipes, running in a northeast-southwest direction, were bowed upward and forced out of the ground. In relaying the pipes, they were not set more than 1 foot deep, from which it is inferred that they were probably not more than 1 foot deep before the earthquake.

In front of the Holy Cross railway station (plate 96A) the tracks of the main line of the Southern Pacific were slightly bent, but the lighter rails of a side track near by were much more disturbed. Around the station the ground had settled and there were a number of cracks, from 4 to 6 inches wide, but these were probably due to the fact that this ground had been filled in to get the required grade for tracks and the station.

*Landslides.* — North of Holy Cross Station, by a little lake west of the cemetery, there was a large landslide along the roadbed of the Southern Pacific Railway. For about 300 feet the bed caved and in one place the west track was left suspended in the air. West of the railroad there were large cracks in the newly filled grounds of the Woodlawn Cemetery.

One hundred feet west of the Southern Pacific Railroad track is the electric line of the United Railroads between San Mateo and San Francisco. This roadbed was also filled in considerably for the required grade, and was not as well settled as the Southern Pacific tracks, so it suffered more severely. West of the Holy Cross Cemetery, the rails were distorted and pulled apart 3 or 4 inches at the joints, due mainly to the dropping of the roadbed. Poles were out of true, but no wires were seen broken from tension or the swaying of the poles.

Northeast of Mount Olivet Cemetery there was an earth-flow in the sandy soil at the base of the San Bruno Mountains. The angle at which the materials slid was hardly more than 10 degrees. The sand and water forming this slide came out of a hole several hundred feet long and 150 feet wide, flowed down the hill several hundred yards toward

the cemetery, carried away a pile of lumber, and knocked the power-house from its foundations. The front of the mud-flow piled up in a bank when it reached the nearly level ground, and dammed up the mass behind it. The earth was harder several weeks later than it must have been at the time of the flow, but it was still slushy and there was still a little water flowing along the path of the earth-flow, coming from a small spring where the slide originated.

On the west bank of a creek, near and parallel to the line of the railroad southwest of Holy Cross Cemetery, there was a crack several hundred feet long. This was along the bank near the creek bed and was an incipient landslide.

On the east edge of the hills west of the Chinese Cemetery and 9-mile house, a line of cracks extends for a distance of about 1,000 yards. These cracks are more than a foot wide in places, and there is an apparent downthrow on the northeast; in one place there is a long line of crushed earth, such as occurs along the main fault-line. Inspection showed that these cracks were caused by a slight landslide. The line of crumbled earth was due to the earth above it on the hillside sliding slightly, and the crumbling represented a line of buckling of the crust.

These cracks are upon the top of a hill, at an elevation of about 400 feet; their general direction is about N. 40° W., and parallel to the San Andreas fault, and the line of hills here has the same general trend.

A line along the east edge of the hills, then, would naturally have the same trend as that of the main fault. A continuation of these cracks would go to the ocean thru Wood's Gulch, which is along the line of a small fault; but no evidence could be found showing any visible movement at the time of the late earthquake. There were several large landslides on both the southwest and northeast sides of the gulch, and at the ocean the amount of dirt that had fallen was very large. These things show a high earthquake intensity, but there is no evidence of other movement.

*The coast north of Mussel Rock.* — Along the coast from Mussel Rock to Lake Merced the section known as Seven Mile Beach presented steep cliffs from 1 to 700 feet in height. These cliffs are composed of the beds of the Merced series, which are soft clay and sandstones only partially consolidated. Along the face of these cliffs the Ocean Shore Railway had started a grade at an elevation of about 300 feet above tide level. Along this bluff a large amount of earth slid down the slopes at the time of the shock. This caving of the banks was due to the nature of the soil, the proximity to the fault-zone, and the disturbance of natural slopes due to the railroad terrace near the top.

In places this slope toward the ocean was brought about to the angle of the repose of this material and the roadbed was entirely destroyed for a distance of 3 miles.

On April 25, the writer was on the edge of the cliffs near Wood's Gulch. About 3 P.M. of that day there was a shock with an intensity estimated to be between VI and VII. At that time the cliffs shook like so much gelatine, and it was necessary to hold on to prevent falling. On the north side of the canyon, hundreds of tons of earth fell even with this light shock.

Along the top of the cliffs large cracks were formed to a distance of several hundred feet from the edge. Many of these cracks were a foot or even as much as 3 feet in width, and small scarps were often present, 4 or 5 feet high and 20 or 30 yards long. The general tendency was for everything to slide into the ocean, but this was not always true. Miniature scarps of more than 6 feet were seen with a downthrow upon the northeast or inland side. The Merced beds, as a whole, were badly shaken, and broke up all along the coast section. Near Mussel Rock part of the roadbed slid for about 500 feet and on the hillside above the road there was a long crack which was the beginning of a slide that might have taken a large part of the hill. The direction of this crack was about N. 45° W., which is more toward the north than the fault-line at this particular place.



A. Woodlawn Cemetery, south of San Francisco. A. O. L.



B. Hills of Eternity Cemetery, south of San Francisco. All firm gables thrown out. Parapets thrown in on roof. A. C. L.

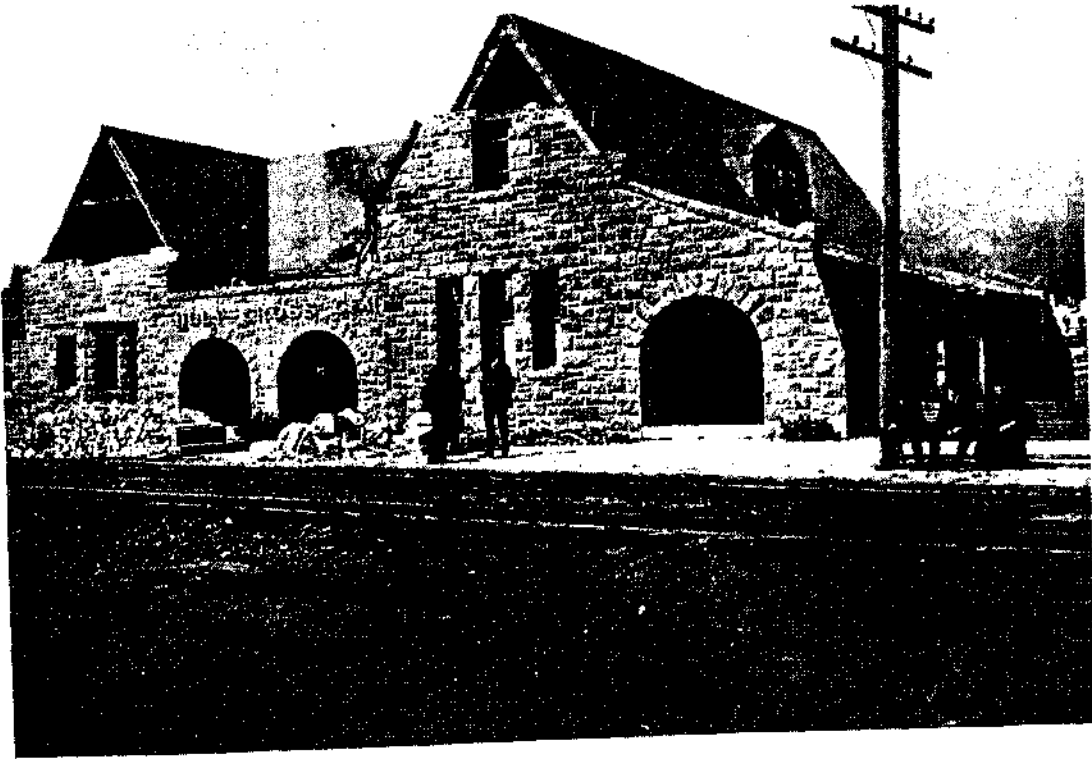

A. HolyOroas OametyxStation.BOUtaofSanFranoiaco. BuUding on made ground. A. 0.1.



T< HolyCxo^Camatery.mt^fSasFraBd^ A. 0.1.

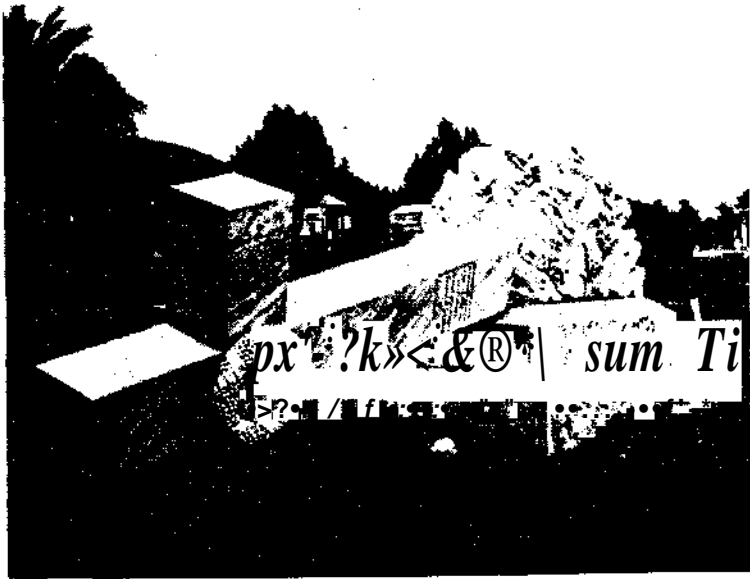

A. Overtbrowm monnment, Holy Cross Cemetary. E. B. M.

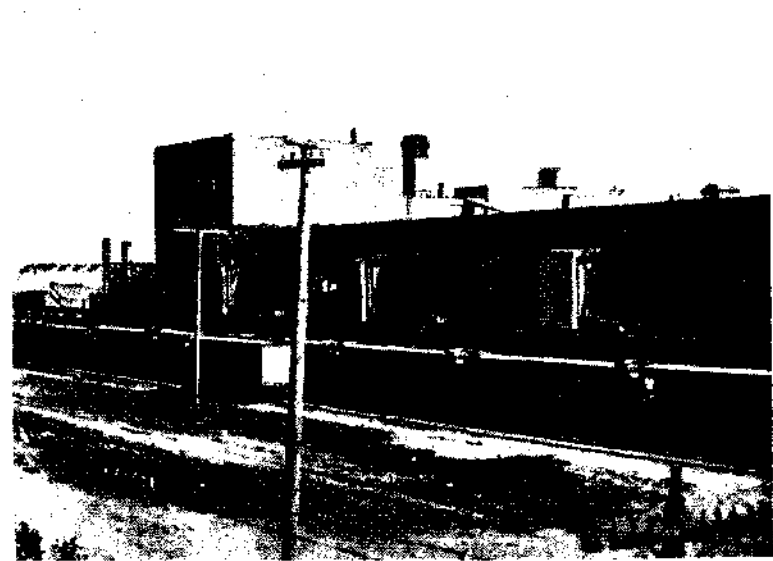

Briok bnilding and high olimney left standing. South San Franaisco. E. B. M>

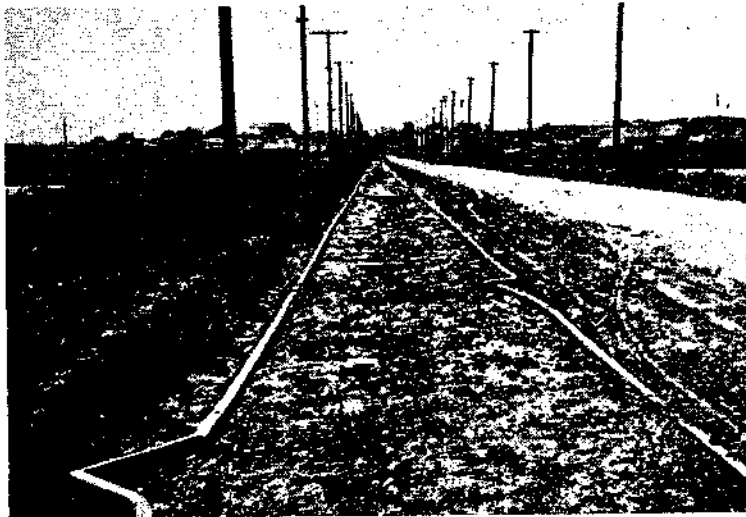

0. Eoadbed and rails of electric railway on marsh west of San Bruno. E. B. M.



D. Eoadbed and rails of electric railway between Baden and San Bruno. E. B. M.



A. Wreck of 1-story brick railway warehouse, Beaufort, N. C. Per J. O. B.



B. Brick stable, Sacramento, Calif. Upper story was thrown out and roof dropt onto story. Per J. C. B.

*Lake Merced.* — About 6 miles north of Mussel Rock, where the Merced beds disappear under seolian sands, the disturbance seems to have been quite violent. An old railroad trestle, that crosses the northern end of Lake Merced in the narrowest place, was badly wrecked. This bridge was broken in two places, and the intermediate piece was out of line with both ends. The direction of the offsets was very nearly due north and south. At one break the west piece was shoved 12 or 14 feet past the other section. The west end of the intermediate piece failed to join the section at the west bank by 6 or 7 feet. The west section that remained with the bank was from 4 to 5 feet lower vertically than the intermediate piece. The trestle was old, built of heavy timbers on a sharp curve, and not in use, which will in part account for its destruction. The swaying of this bridge destroyed a section of it 50 to 60 feet long. On the hillside where this trestle reaches the west bank of the lake, cracks parallel to the shore line suggest the cause of the destruction of the bridge. The displacements here are larger than any along the main fault-line, and it is apparently entirely local, due to the slipping and settling of the west bank of the lake.

Upon following around the north end of the lake to the road that runs to the Life Saving Station, a line of terra-cotta pipe, about 8 inches in diameter, was found. There was no large displacement found in this pipe, altho it had been cracked at many points. There is nothing in these phenomena to show that there was a fault thru the Merced Valley.

Just south of the bridge across Lake Merced, a sand-bar was forced up out of the lake, from water that was previously 6 or 8 feet deep. This bar is parallel to the west bank of the lake, and has a direction almost due north and south. This was probably caused by the same thing that wrecked the bridge; that is, the displacement and settling of the west bank of the lake at the time of the earthquake.

#### THE AREA SOUTHWEST OF THE SAN ANDREAS FAULT.

*Difference of apparent intensity on the two sides of the fault.* — On passing from the beds of the Merced series on the northeast to the southwest side of the fault, there is a marked difference between the distribution of small cracks and little earthslides. On the northeast side, in the Merced beds, these cracks and landslides are common, but on the southwest side they are entirely absent. This can hardly be taken to show that there was any difference in intensity on the two sides of the fault; it is probably the result of the difference in the character and stability of the rocks. At other places north of the fault, but southeast of the Merced beds, this difference has not been noticed, probably because in that part of the area the rocks are nearly all Franciscan.

On the south side of the San Andreas fault there are no towns affording an opportunity for judging the intensity of the shock. The gradation must of necessity be based upon something else. Landslides occur both near the fault-zone and at a distance from it, under somewhat similar geologic and topographic conditions. It seems to be a fair assumption that a landslide is indicative of a high intensity.

*Laguna Salada Valley.* — In the valley of Laguna Salada, the Ocean Shore Railroad had a temporary trestle erected for making a fill in the valley up to required grade. This trestle was twisted and thrown out of line, and the earth sank along the newly filled roadbed. Similar things happened to newly filled roadbeds along the west edge of the Santa Clara Valley, near Baden and San Bruno.

Along the base of the cliffs south of Laguna Salada, there were several small slides, some from the face of the hills and others in the newly graded roadbed. There were many small cracks along the tops of the cliff, parallel to its edge, showing that the face of the bluff was shattered, and that more earth might slide. One big rock pinnacle, which had been left above the roadbed as a landmark, and which had seemed a little dangerous before, was shaken down.

*Calera Valley.* — In Calera Valley the shock was severely felt by people in some small temporary shacks: South of this place, in the San Pedro Valley, two old wooden houses showed no structural damage, and only one of two brick chimneys was thrown down.

*San Pedro Point.* — From San Pedro Point southward for about 1.5 miles, the cliffs rise to heights of from 400 to 800 feet. The railway company had cut a bench for its roadbed several hundred feet above the ocean. This roadbed, being largely in solid rock, was for the most part not much injured; but in some places it was obliterated by rock slides that came from above.

Just north of the point known as Devil's Slide, there was a landslide of the whole face of the west end of Montara Mountain. It started at about 800 feet above the sea, and swept down carrying many hundred feet of roadbed along with it. The material that slid was sandstone and granite, but it seemed to be much weathered and softened in places, so that it was loose ground.

South from the Devil's Slide to the first small coast valley, there were landslides along the cliffs. The rock in this vicinity is massive granite, but the landslides showed that the rock had disintegrated for a considerable distance below the surface and the slides were in this decomposed rock. Wherever the railway bed was filled or built out with this material, there was more or less sliding and settling, caused by the earthquake.

*Montara Point.* — The old, low brick structure at Montara Point did not show any effects of the shock, but there was some damage to a wooden tank-house. One of the tanks, which was previously known to be old and rotten, collapsed entirely. In the yard of the keeper is a concrete water cistern which holds over 6,000 gallons, and which is set flush with the ground and protected with an iron cover that two men can hardly lift. At the time of the shock this tank was almost full and had the cover on. The violence of the shock was sufficient to throw this cover 10 or 15 feet, and spill about 3,000 gallons of the water in all directions.

The observations of the light-house keeper are considerably at variance with what some people have said regarding the behavior of the ocean at the time of the earthquake. Many persons told of waves that had rolled high up on the cliffs. The keeper reports that during the actual period of shaking the ocean was smooth, without even the customary motion. After the shock had ceased, it was perhaps half a minute before the calm was broken and the regular swell began. He reports that he was upon his feet at the time of the shock, and altho used to being on shipboard, could stand only with great difficulty.

This testimony as to the appearance of the water is almost the same as that of the light-house keeper at San Mateo Point. There was no evidence anywhere along the coast to show that the water rose above tide-level.

On the southwest face of Montara Mountain, nearly all of which is visible from the road, no landslides of any size were observed.

*Landslides.* — South of Montara Point, in the low foot-hills north of Half Moon Bay, there were two large low-angle landslides or earth-flows. One of these landslides was on the low foot-hills facing the ocean; the other on the northeast bank of Frenchman's Creek, several miles northeast of Half Moon Bay.<sup>1</sup>

From Half Moon Bay to San Mateo, there were several large slides of different character from those already mentioned. These resulted from the slipping of large masses of rock, many of the fragments in one of the slides being over 20 feet in diameter. (See plates 124c and 126B.)

On the south face of Scarper Peak, and on the southwest face of Ox Hill, there were several landslides both large and small. No photographs of the larger slides are available.

About 4 miles east of Half Moon Bay, just off the south edge of the San Mateo sheet, there was another large earth-slide similar to the two already mentioned.

---

<sup>1</sup> These are described by Mr. R. Andemon in the section dealing with Earth-flows.



*Pilarcitos Canyon.* — In Pilarcitos Canyon, the stone dam of the artificial lake was uninjured and the flume down the canyon sprung only a few leaks. Mr. Ebright's house, at the lower end of the lake, lost two out of three chimneys by the shock. The spring water at this place, which is used for house supply, is said to have been milky-white during the day of the earthquake. This canyon is made by one of the large faults mentioned in the first part of the paper. If there had been any movement along this fault, it would have been shown at the dam which crosses the canyon at a right angle to the fault-line.

*Cahill's Ridge.* — This range of hills forms the northeast side of Pilarcitos Canyon, and is the second ridge southwest of Crystal Springs Lake, with the same general northwest-southeast trend. On the top of this ridge, a small house lost one of two chimneys, and things inside were shaken around. A table is said to have tilted enough for dishes to slide off.

Just southeast of the house is a depression in the ridge, across which furrows and cracks formed similar to those along the main fault-line, but not extending more than several hundred feet. These cracks do not seem to have been landslide cracks, for they are on top of the ridge and on a flat piece of ground.

Another peculiar phenomenon was observed upon Cahill's Ridge, less than 1 mile northwest of the cracks mentioned. In an area of limestone, a small patch some 30 feet in diameter was torn up as tho it had been plowed and harrowed, and no large pieces of sod were left intact. Around this in various places were cracks of a few inches in width, with one or two over a foot wide. There was a slight downthrow on the uphill side to be noticed in some of these cracks, which eliminated the possibility that they were cracks preparatory to landsliding.

*Sawyer's Ridge.* — On Sawyer's Ridge, about 9 miles north of the region described on Cahill's Ridge, there were cracks several hundred feet long almost at the top of the ridge. These were parallel to the line of the main fault, which is a mile to the east, and there was a marked downthrow of from 2 to 3 inches on the southwest side, which in this case was the uphill side. If the downthrow were on the downhill side, then it could be possible that these were landslide cracks. The exact cause or mode of the formation of these cracks, or the breaking of the ground on Cahill's Ridge, is not clear.

In the canyon between Sawyer's Ridge and Sweeney's Ridge, a 2-story wooden house did not suffer much, and out of 4 chimneys only 2 were cracked. One of those that remained standing was a tall top-heavy chimney of brick; the other was only a tin pipe.

At Byrne's store, on the Half Moon Bay road, half a mile west of Crystal Springs Lake, it was reported by the keeper that the water from their spring, on the day of the shock, was muddy and was not tasted. On the second day after the earthquake, it had a very salty taste, but on the third day was normal. A house on the northwest side of Half Moon Bay road, 2,000 feet southwest of the dam, was thrown from its foundations, while some 200 feet northwest of this house there was a slide in the canyon.

#### CONCLUSIONS.

There was no marked difference of intensity on the two sides of San Andreas fault-line.

There was a decrease of intensity on both sides of the fault-line, as one goes away from it.

The distribution of intensity bears no evident relation to the minor faults or structure of this area.

It is evident that the intensity varies with the geology, or with the areal distribution of rocks and soils.

The areas that suffered most severely were those upon filled ground.

Areas upon marshy ground showed destructive effects similar to artificial filled land.

Next in intensity to areas of filled land are those upon incoherent sands. The damage in sandy areas was due partly to the shaking of sand like jelly and partly to settling and sliding.

Areas that suffered least were upon rock of some kind in place.

Towns along the west edge of the Santa Clara Valley, at equal distances from the fault-line and upon similar geological formation, showed the same intensity.

The waters of the bay and of the ocean were quieted by the shock, and there was no perceptible tidal wave following the movement.

The shock was not felt as strongly upon the waters of the bay as upon the land near by.

There was an unusual flow of water in the creeks draining into the bay near Baden and San Bruno, directly after the shock.

The destruction of buildings and the disturbance of railway roadbeds and rails was much more violent thruout the area covered by the incoherent Merced beds than on the older hard rock in the adjoining areas.

There was a large amount of damage done in the cemeteries, which are on seolian sands.

A large number of the monuments fell at the cemeteries, but there was no consistency in the direction of falling to show the direction of motion.

Motion in more than one direction was suggested by monuments twisted upon their bases. Vertical motion was shown in one monument which had the upper portion turned upside down.

#### NOTES BY OTHER OBSERVERS.

*San Mateo, San Mateo County* (Mr. Maxwell). — At the time of the shock Mr. Maxwell had led a horse out of the barn to give him water. He first heard a heavy rumble, which he took for thunder, coming from the northwest. This was followed by a wavy motion of the ground. The earth rose and fell like the swell of the sea, the waves being about 3 feet high. A water-tank about 30 feet high tipped over to the southeast so as to throw water out and allow him to look into the top of the tank, he being 75 or 80 feet distant. The tank swayed back to its place without falling. The two wave motions were followed by a severe shock, as if the waves from the northwest and southeast met suddenly under him. Both he and his horse were thrown off their feet. The horse attempted to run, but could not on account of the violent motion of the earth.

*Redwood* (E. C. Jones). — The mains of the gas plant are all of steel and suffered no damage. The gas-generating apparatus was moved several inches on its foundation, and all cast-iron connections were more or less damaged. The buildings, being of frame and corrugated iron, were not seriously damaged. A 20,000-foot gas-holder in a redwood tank above ground was completely demolished by the earthquake. The shock seems to have been particularly severe at Redwood City, and the boiler settings at this station were badly damaged, while at San Mateo, 9 miles distant, the settings were uninjured.

# THE CALIFORNIA EARTHQUAKE OF APRIL 18, 1906

---

## REPORT OF THE STATE EARTHQUAKE INVESTIGATION COMMISSION

---

IN TWO VOLUMES AND ATLAS

---

VOLUME I, PART II



WASHINGTON, D. C.  
PUBLISHED BY THE CARNEGIE INSTITUTION OF WASHINGTON  
1008

CARNEGIE INSTITUTION OF WASHINGTON

PUBLICATION NO. 87, VOLUME I, PART II

Printed by  
J. S. Goring O. — Lippincott A Smith Co.  
N(11-11, Ma-s., U. S. A.

## PART TWO.

---

### ISOSEISMALS: DISTRIBUTION (W APPARENT INTENSITY-CONTINUED).

AREA OF THE SANTA CRUZ QUADRANGLE OF THE U. S. GEOLOGICAL SURVEY.

The distribution of intensity in the area of the Santa Cruz Quadrangle was studied by students of Stanford University, under direction of Prof. J. C. Branner. The contributors to data embodied in this part of the report are Messrs. R. V. Anderson, H. W. Bell, B. Bryan, R. E. Collom, R. Crandall, P. Edwards, H. P. Gage, F. Lane, R. Moran, R. L. Motz, A. F. Rogers, S. Taber, A. F. Taggart, F. W. Turner, and G. A. Waring.

*Stanford University* (J. C. Branner). —Referring to the group of dwellings southeast of the University quadrangle, there were 61 residences on the campus of Stanford University at the time of the earthquake. Out of 140 chimneys on these buildings, 104 were thrown down, or 74 per cent. The plaster was generally badly broken on the first floors of these buildings, and less injured tho generally more or less cracked in the second-floor rooms. At No. 13 Alvarado Row, first floor, several pictures 18 inches across, and hanging by cords 4 feet long, were swung so far that they were left with their faces to the wall. On the corner of Saivatierra and Aguello Streets, a frame building occupied by the Chi Psi Fraternity was so badly wrecked that it had to be abandoned. The injury done this building was due to its having stood upon posts 4 feet high and nut well braced; the swaying of the building threw it off these supports.

President Jordan's residence, west of the quadrangle, had 3 brick chimneys, all of which were thrown down; the plaster WLS so badly injured that the first floor, the ceilings, and part of the second floor had to be replastered. This building rested upon a brick foundation about 4 feet high.

The Stanford residence, a mile north of the quadrangle;, was so badly wrecked that it has since been torn down. The original building was of brick, and wooden additions had been built on the northwest and southeast sides of the brick portion. The additions stood upon wooden uprights 4 feet in length. The southeastern wooden addition was thrown from its supports and fell away from the older brick portion. The brick portion of the structure was badly shattered. In the grounds and parks about the residence there were many marble and bronze statues from 4.5 to 5 feet high, standing on pedestals from 2 to 4 feet high. These were all thrown down, except a few that were very securely bolted to heavy pedestals. There was no uniformity in the directions in which they fell.

Between the Stanford residence and the museum, a large 2-story brick winery had the 4 gable ends thrown down. The northwest gable fell into the building, the southeast gable fell outward, while the gables on the northeast and southwest sides fell outward.

Mr. Charles G. Lathrop's residence is not on the valley floor, like the other buildings in the immediate vicinity of the University, but stands on a hill of sandstone nearly 300 feet above the level of the bay. Out of the 4 brick chimneys on his house 2 were thrown down; 2 water-tanks 53 feet high (10-foot tanks on 43-foot supports) were not injured, but about two-thirds of the water was thrown from them.

Professor Durand's house, south of the quadrangle, is on a hill 160 feet above the bay mid stands on the upturned edges of gravel beds that underlie the Santa Clara Valley. Of 3 chimneys, 2 were thrown down, and the plaster was cracked on the ground floor.

Of the University buildings proper, pome were unhurt while others were completely wrecked. (See plate 1()2n.) They all stitnd upon tin; loon\* gravelly louut of the Santa

Clara Valley floor. As a rule, the older the buildings were the better they withstood the shock. Much damage was done by the throwing down of stone chimneys. The 150-foot stone chimney of the power plant was thrown down, crushing part of the boiler house and killing a fireman. The double-flued 60-foot chimney of the assay laboratory fell. The large stone chimneys of the dormitories were broken off at the roof edges and fell into the buildings. At Encina Hall, the men's dormitory, one chimney fell thru the roof and carried down a tier of rooms into the basement, killing one student. The south ends of the wings of Encina Hall were so badly cracked that they had to be entirely rebuilt. It was found that the injury done to the ends of the wings was due to the relation of these particular walls to the roof beams. Excepting the cracking of plaster, Encina Hall was not otherwise injured, tho it is a 4-story building, with basement and attic.

The chimneys also fell from Roble Hall, the women's dormitory, and did some damage to the roof and upper floors; but the building, which is of concrete, was otherwise unhurt.

The Chemistry building had 32 tile-lined stone ventilating chimneys projecting 12 to 16 feet above the roof, besides 2 ordinary stone chimneys; these were all thrown down.

The stone tower of the church was shaken to pieces, and in falling destroyed the parts of the roof immediately around the tower. The north gable end of the church was thrown outward into the quadrangle. (Plate 103B.)

The top of the memorial arch was broken off down to the upper part of the frieze, and in falling it wrecked adjacent portions of the arcades to the east and west. (Plate 103A.) The parts of the arch left standing were cracked. The 2 smaller arches at the east and west ends of the inner quadrangle were slightly cracked near the top, but they were not seriously damaged.

Besides the damages to the church and the memorial arch, the most serious injury to the quadrangle group of buildings was done to the larger structures. The 1-story buildings, especially those that had been standing for several years, were not damaged beyond the occasional cracking of plaster; and even in these cases the injury was found to be directly related to the method of supporting the roofs upon the walls. The statues of the front fayade were dislodged and one was thrown down. (Plate 100B.)

The 1-story buildings in the outer quadrangle had all been lately put up, and these were somewhat cracked, tho none of them was seriously hurt. The cracks were generally about the ends of the buildings and along the tops of the walls where the roof timbers rested upon them. The higher buildings of the outer quadrangle were more seriously damaged, especially those situated on the cornel's. These buildings are all three stories and basement. The towers on the inside corners of these buildings were all more or less broken and require rebuilding. The Civil Engineering building — three stories and basement — at the southeast corner of the outer quadrangle had its outer walls badly cracked, especially on the north face, and about the tower at its northwest corner. Inside the plaster was injured more or less all thru the building.

The Geology building, at the southwest corner of the outer quadrangle, was the last building of this group to be put up. It was a 3-story structure, and had barely been finished; but it was not yet occupied when the earthquake occurred. Sections of the walls were thrown down from every face of the building. These sections extended from the caves down to the second floor. The tower at the northeast corner was badly cracked and part of it fell. The plaster was broken on all the vertical walls, both on the outside walls and on the partitions, showing that there was much internal wrenching of the building. The walls of this building will all have to come down and be rebuilt from the foundation. (Plate 102A.)

The inner arcades of the quadrangle were not much affected. At one place on the south side of the memorial court, where the arcades are not directly connected with any other building, they were so violently swayed that they seem to have come near falling. They were found to be 7.75 inches out of alincmct after the earthquake, and the tops of the bases of the supporting stone columns were chipped off. (Plate 105iiO)



L. Wreck of 2-story trick building, San Mateo. Per J. O. B.



B. Wreck of 2-story brick buildbg, San Mateo. Per J. C. B.



A. Trestle carrying a 30-inch water pipe across Frawley Q-nloh demolished by shock. E. L. H.



B. Statue of Agassiz thrown from its niche above archway, Stanford University. Per J. O. B.





A. Destmouitiou of arcade at Sacred Heart Convent, Menlo Park. E. O.



B. Gateway of Campus, Stanford University. Per J. O. B.

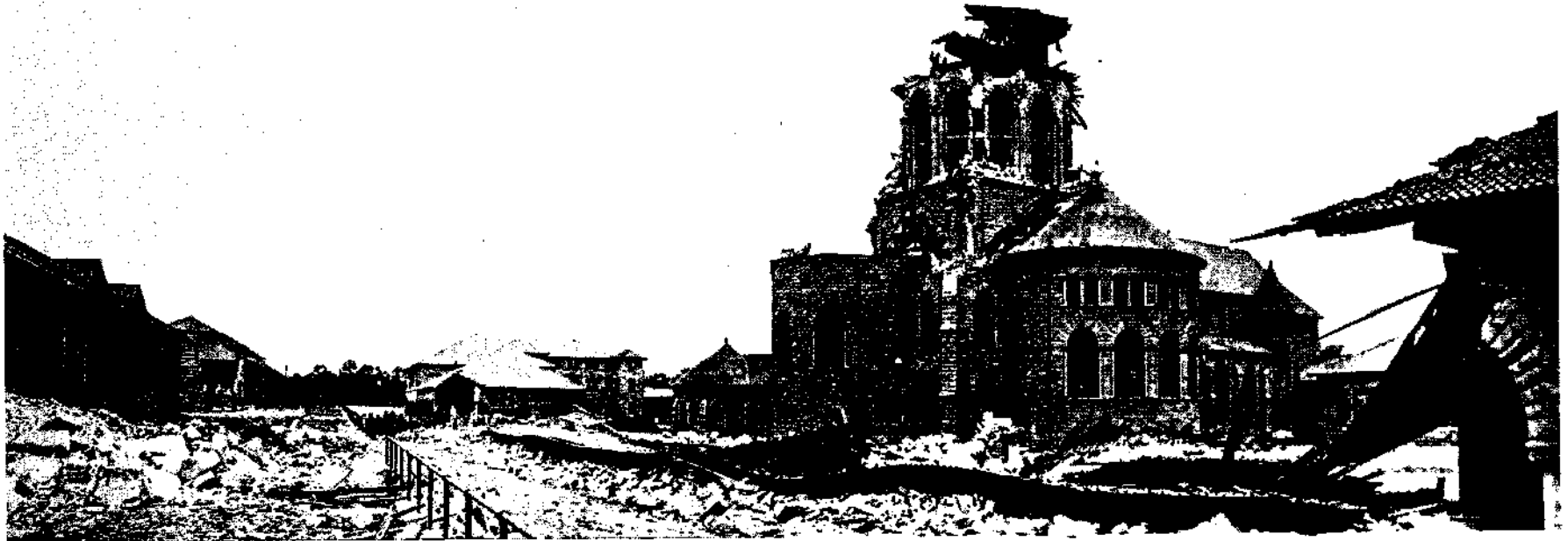
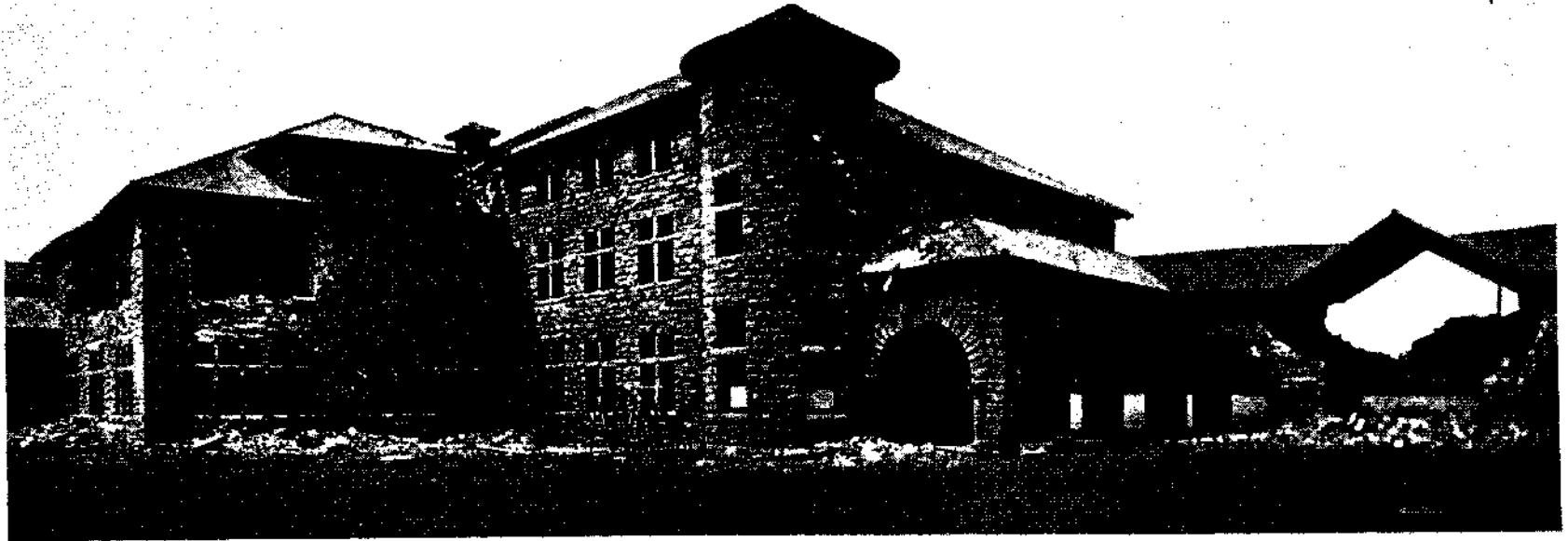

A. Geology Building, Stanford University. Per J. O. B.

B. Panorama of destruction, Stanford University. Memorial chapel in middle right. Per J. O. B.

The arcade along the south side of the outer quadrangle that was not directly connected with the other buildings was completely wrecked. The arcade in front of the French building on the east side and a corresponding piece in front of the Physics building on the west side of the outer quadrangle were thrown down. South of the business office, parts of the outer arcades fell. This is on the east side of the quadrangle. Parts also fell south of the Mineralogy building, on the west side of the outer quadrangle. (Plate 105A.) The arcades around the memorial court are only partly in direct connection with buildings. The free portions appear to have swayed so far out of the vertical that the bottoms of the stone columns supporting the arches were chipped off, or cracked at their bases. The 2-story woodworking shop of brick, south of the quadrangle, was badly damaged; and the forge building, next to it, also of brick and 1-story, was cracked.

The chemical laboratory, a new stone-faced building (two stories, attic and basement), was so badly cracked that most of the walls have to be rebuilt from the foundation.

The new gymnasium, a stone-faced brick building, was totally wrecked. (Plate 104B.) It had just been put up, and the inside work was not yet finished. The new library, also a stone-faced brick structure, was completely wrecked except a tower of steel on which its central dome still stands. (Plate 104A.) This building had just been put up, and was not yet finished on the inside when the earthquake occurred. The Museum building consisted of an older central portion built of concrete, and extensive additions of brick had just been completed. The new brick portions of the building were almost all thrown down, but the older concrete part was unhurt.

The ornamental stone gateway at the entrance to the university grounds, near Palo Alto, was thrown down. (Plate 101B.)

The water-tank at the Faculty Club-house was wrecked and a water-tank in the fields east of Alvarado Row was overthrown. The large covered tanks west of the stock farm, beside the county road, were not thrown down, but much water was spilt from them.

*Palo Alto* (A. F. Rogers). —The most interesting effects of the earthquake in Palo Alto were those which showed movement of buildings and those which gave evidence of twisting. A number of buildings moved toward the southeast 1 to 6 inches or more. Some buildings were left out of plumb and usually they were inclined to the southeast. In other cases, buildings collapsed and fell toward the southeast. It should be remarked that practically all houses moving to the southeast were those situated on the streets running northwest-southeast. Very few buildings on the avenues (running northeast-southwest) were moved at all. The moved buildings stand approximately at right angles to the fault-line southwest of Stanford University.

A change in the direction of the earthquake movement is suggested by the fact that in several cases the chimneys were apparently twisted from their normal positions. The same is true of several houses that collapsed. The twisting was clockwise in some cases and counter-clockwise in others. A remarkable case of twisting was shown in the house at 727 Cowper Street, where picture frames were tilted from the normal positions.

Chimneys were mostly knocked down, those that remained standing being for the most part in the centers of the houses. The direction of their fall was apparently accidental. A curious case is that of three 1-story frame houses, exactly alike, at 317, 323, and 329 High Street. The chimney on the house at 329 remained standing, while the chimneys on the other two houses fell.

The data upon which those conclusions are based follow:

757 Channing: Small one-story frame house without foundation; chimney standing.

845 Webster: One-story frame house with wood foundation; chimney standing. Chimneys were thrown from the two one-story frame houses next to it.

4M Middlefield: Two one-story shingle houses; chimneys standing.

427 Middlefield: One-story house; chimney in the center of the house stood. Next door, same kind of house, chimney at end of house fell.

427 Hamilton: One and one-half story frame house; chimney in center of house stood, while one at side, of house fell.

427 Hamilton: Two-story frame house; chimney standing.

Hamilton and Middlefield: Two and one-half story frame house; chimneys standing. Chimneys down in houses around it, both one-story and two-story houses.

368 Lytton: Very small frame house without foundation; chimney standing.

Hawthorne near Waverly: Several small houses; chimneys in center of houses standing. Side chimneys on small houses across the street from these were down.

171 Cowper: Tiny one-story frame house; chimney on side of house standing.

317, 323, and 329 High Street: Three one-story frame houses exactly alike, and chimneys in same positions on houses. Chimney at 329 standing; the other two down.

310 High: One and one-half story house; chimney in center standing, one on side down.

Kingsley and Bryant: Two-story stucco house; chimney standing. No damage.

1329 Waverly: Low one-story shingle house; rather high chimney standing.

Boyce Avenue: Two-story rather low frame house; chimney standing.

Guinda Street: Two frame houses, one one-story, other two-story; chimneys standing. Chimneys fell from houses on both sides.

Hamilton and Fulton: One and one-half story frame house, chimney cracked but standing. Very small house next to it, chimney down.

465 Hawthorne: One and one-half story house (first story brick); apparently no damage except chimney down.

347 Melville: Two-story stucco house; chimneys all down-

Forest Court: One very low frame house; chimney down.

253-255 Homer: Two-story double stucco house; plaster slightly cracked, chimneys down.

## EVIDENCES OF TWISTING.

1110 Bryant: Small one-story frame house; chimney at center of house twisted slightly counter-clockwise.

121 Emerson: Small one-story frame house; chimney in center twisted clockwise.

Waverly near Lytton: The Palo Alto Academy, an old two-story frame house, completely collapsed, falling toward the southeast and apparently twisted counter-clockwise.

Emerson, near University Ave.: Two-story frame house was moved off its foundation toward the southeast, and twisted clockwise.

711 Cowper: Pictures on walls; some remained straight, others were twisted as shown in the sketch, showing the four walls of the room. The pictures on the northeast and southwest walls were observed in one room and those on the northwest wall in another room. (See fig. 55.)

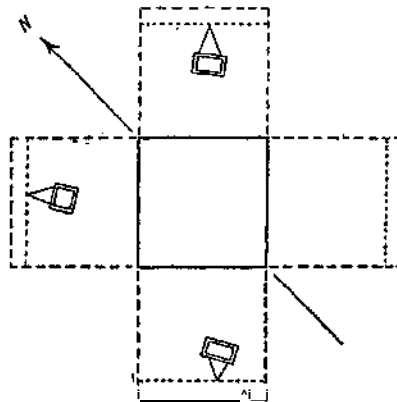

FIG. 55.—Diagram showing displacement of pictures on walls of rooms.

## MOVEMENT OF BUILDINGS.

627 Waverly: Two-story frame house high above the ground and resting on brick foundation; lower part of house moved toward the southeast so that it had to be propt up.

711 Cowper: One and one-half story frame house high off the ground; 6 inches out of plumb in rear.

745 Cowper: One and one-half story frame house, high off the ground; several inches out of plumb.

538 Emerson: Two-story frame house; first story moved 2 inches toward southeast.

439 Alma: One-story stable moved a little to the southeast.

129 Emerson: Two-story frame house several feet above the ground was moved 3 feet toward the southeast and set down on the ground.

Luscher Building, 251 High: Two-story frame building; moved toward the southeast several inches, and apparently twisted counter-clockwise.

Palo Alto Hotel, Alma and Lytton: Three-story frame hotel moved toward the southeast.

Greenhouse, near San Francisquito Creek: Very little damage; a few panes of glass broken. The benches moved toward the southeast from 0.5 to 1 inch.

Ruthven and Cowper: New one and one-half story shingle house with concrete foundation; chimneys standing. House propt up on southeast side.

Dudfield Lumber Yard: Piles of lumber moved in various directions, but mostly toward the southeast.

Forest and High: Lumber shed; lumber piles on each side of open central space partially collapsed. Lumber piles on northwest side moved toward the southeast; those on southeast side remained in place.

Bleiber Blacksmith Shop: Two-story frame building; lower story moved 4 inches toward the southeast.

Alma, west of University: New three-story artificial stone building fell toward the southeast.

Alma, east of University Avenue: New two-story artificial stone building; collapsed and fell toward the southeast.

444 High: Two-story brick business house; first story moved toward the southeast.

## MISCELLANEOUS.

The bridges across San Francisquito Creek, at Bryant Street and Middlefield Road, apparently were not damaged.

University Avenue and Romona Street: Jordan Building; three-story stucco business building. Plaster on first story badly cracked.



A. Enin of Memorial Arch, Stanford University. Per J. O. B.

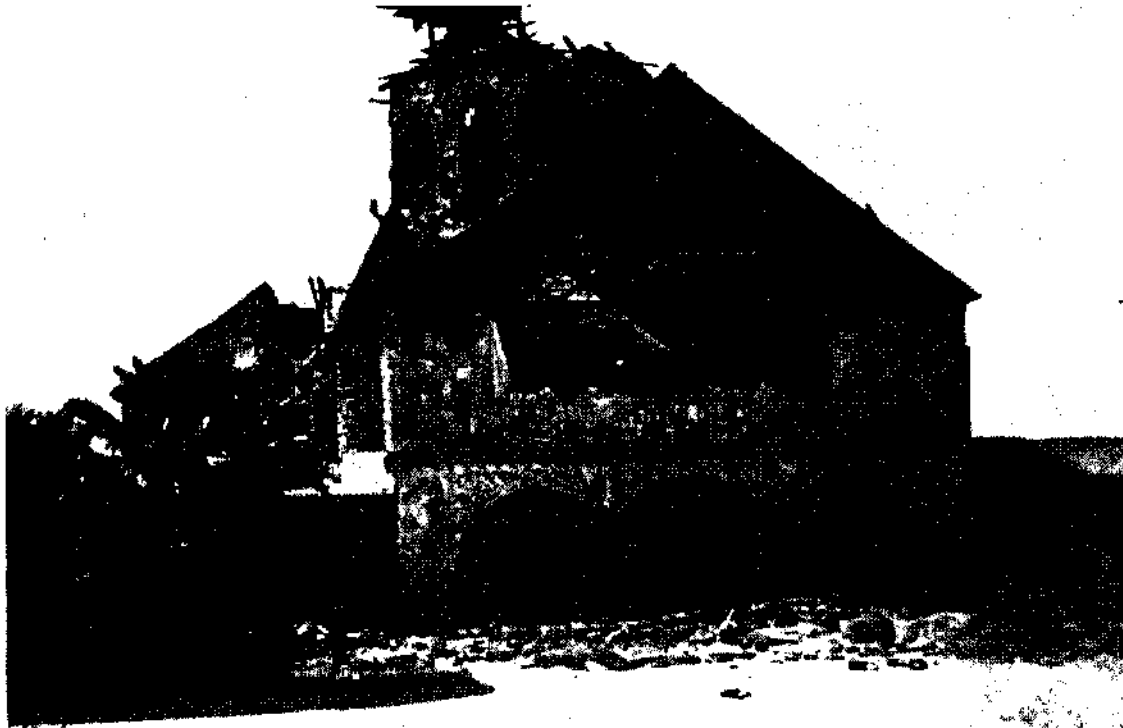

B, Front Yiew of Memorial Chare!, Staoford Unimrtitj,

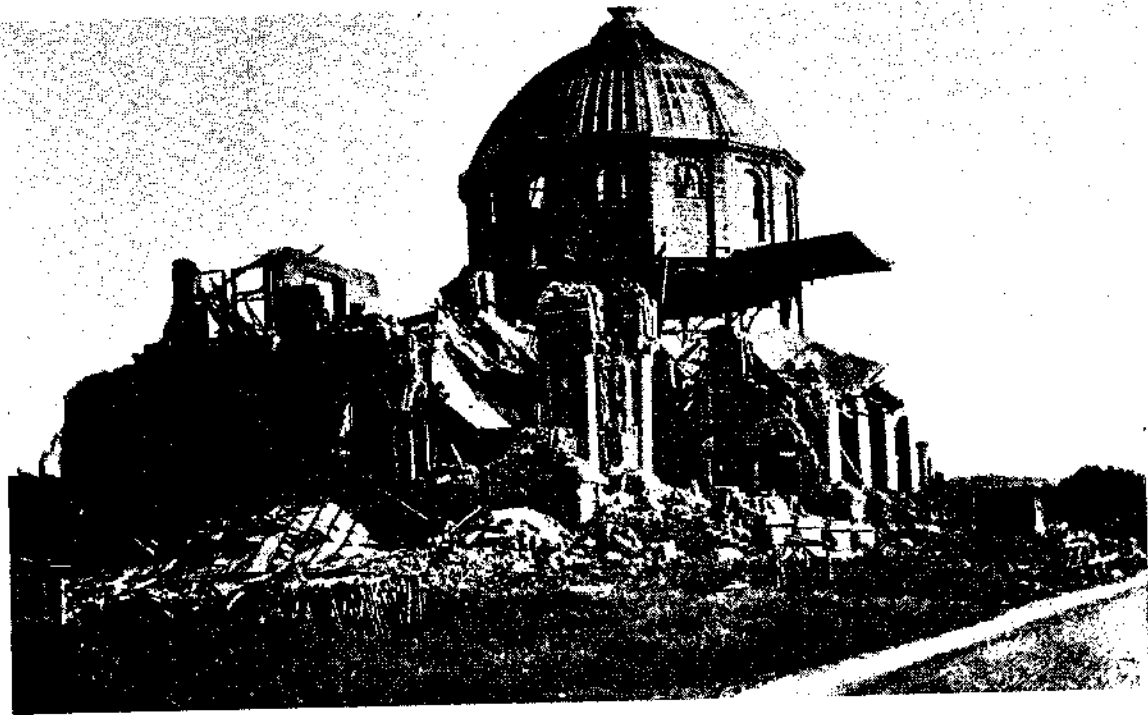

A. "Wreck of Library Building, Stanford University. Par J. O. B.



B. Wreck of Gymnasium Building, Stanford University. Par J. O. B.

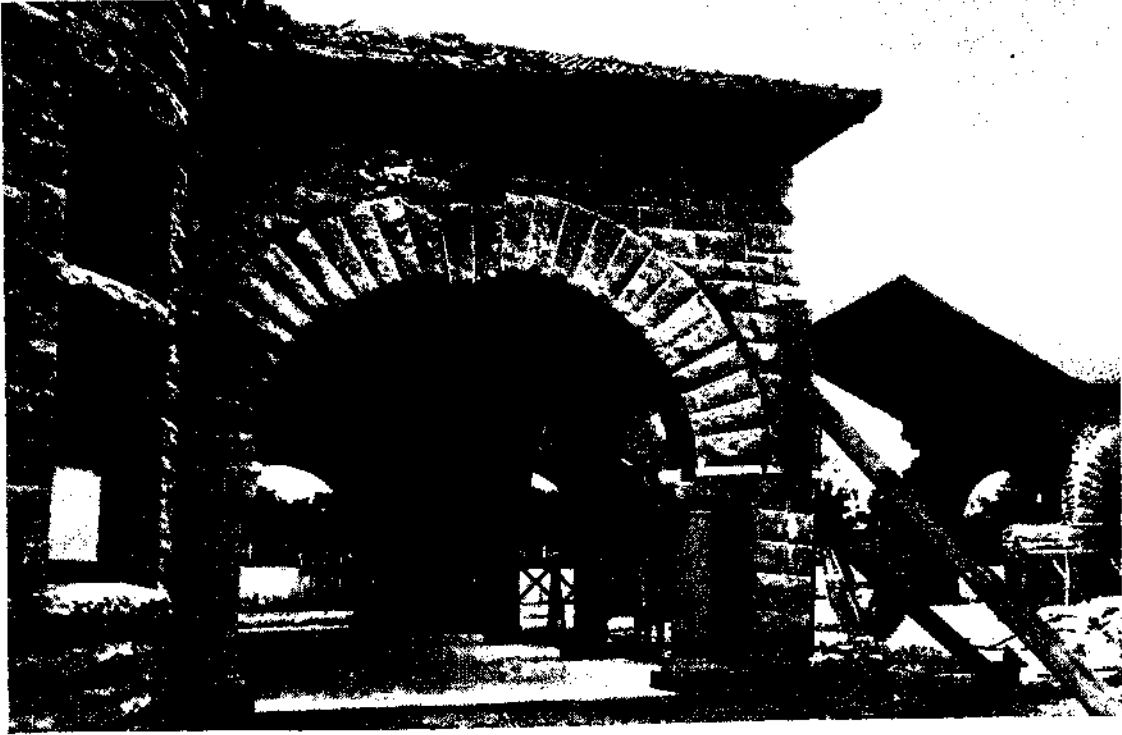

A. "Wrecked arolea, Geology Building, Stanford University. Per J, O. B.

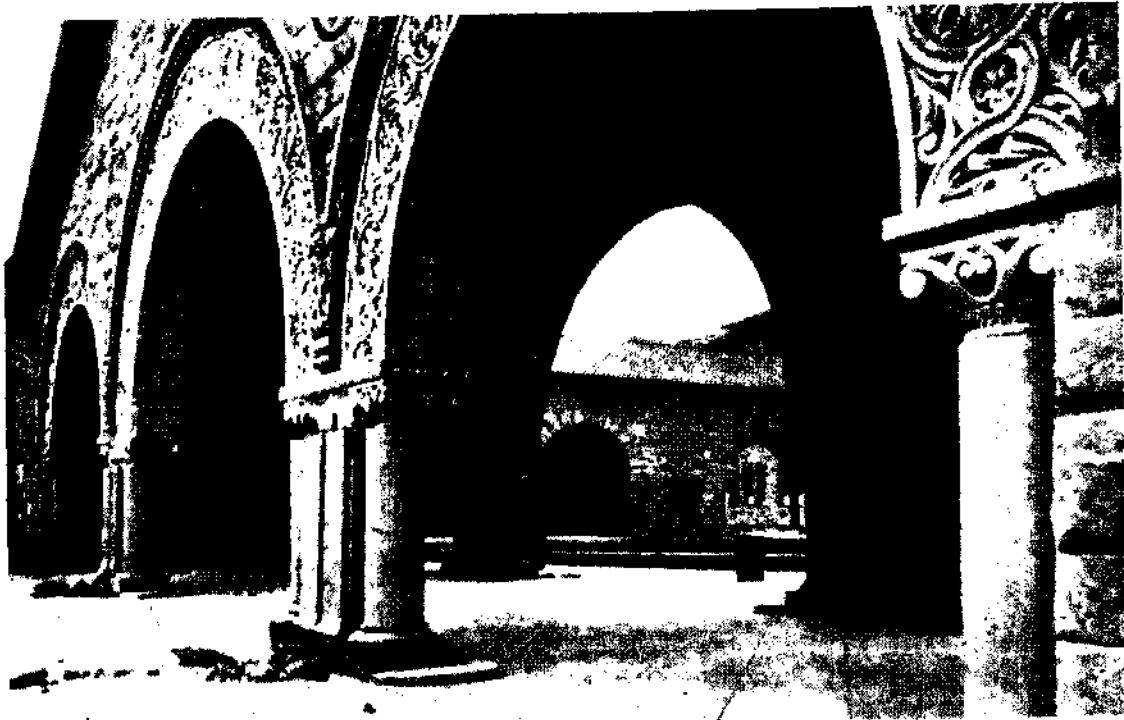

B. ATches that mored on their supporting oolmnni. Stamford Uniwwity PMJ- • B.



A. Tree oTerthrown by earthquake, west of Searsville Lake, Per J. O. B,



B, LIT« oak uprooted \tj eartbqmfa, weit of Beawill\* Lake. Per J. G. B.



*Menlo Park* (H. P. Gage). —At the Catholic Seminary near Menlo Park, a 4-story brick building, the upper part of many of the walls fell; towers and chimneys also came down; arches were sprung apart, allowing their keystones to drop, catch, and hang. There were many cracks in all the walls which remained standing; the capstones above the windows on the fourth floor fell out. The chapel behind the northeast side wall was thrown in a heap. The 1-story brick buildings back of the large one were little damaged; a wooden tank was uninjured, altho it was on an 80-foot tower like the one in the building which fell. The round power-house chimney (35 feet high) was cracked in the middle and the top broken off. A mile nearer Fair Oaks Station, a water-tank only 12 feet high was thrown down. With this one exception all the tanks on this side of the county road appeared to be standing.

(F. Lane.)—A water-tank beside the road, passing north of the cemetery 1.5 miles southwest of Menlo Park Station, was thrown down; while one about 0.25 mile nearer the station on the same road was left standing. On the second road west of San Francisquito Creek, and running southwest from Menlo Park Station toward the Alameda de las Pulgas, three large trees growing together had been torn apart, and one about 2.5 feet in diameter had fallen. Water-tanks on the second road west of San Francisquito Creek were not thrown down. On the second parallel road west of the Creek, and leading southwest from Menlo Park and 1 mile from the station, the roof of a large 3-story brick house, which had been recently built, had collapsed, the bricks having been shaken from the walls down to the second floor. The Arcade of the Sacred Heart Convent was thrown down. (Plate 101A.)

*Fair Oaks*. — On the road leading southwest from Fair Oaks and about a mile southwest of that station, a newly completed 1-story bungalow had entirely collapsed.

(S. Taber.)—At a stable near Fair Oaks (about a mile southeast of the junction of the Woodside Grade road with the road leading across University Heights) heavy carriages and wagons were moved sidewise 6 inches in a direction N. 37° E., but they did not roll out on their wheels. These carriages were placed on the northwest side of the barn.

(H. P. Gage.)—Following the road from Fair Oaks toward Cooley's Landing, a house with poor underpinning fell over, also the woodshed near it. An engine mounted on a platform 2 feet from the ground was not upset. People reported new holes formed in the slough near Cooley's Landing, but their statements were not verified. No damage except broken chimneys was noticeable in the vicinity of the Landing, and solidly built houses seemed to be intact. One house on a poor foundation was knocked down; while the barns, tanks, etc., belonging to it were uninjured.

(F. Lane.)—South of Menlo Park and east of the Meyer Place on the west side of San Francisquito Creek, a crack about 1.5 inches wide ran for 20 feet along the edge of the county road parallel to and just above the creek, showing a half-inch vertical displacement, the lower side lying next to the creek. This crack appears to be due to the starting of the filled ground of which the road is partly made. The water in the reservoir of the Bear Gulch Company, 3.25 miles west of Stanford University, is reported to have been thrown about 25 feet beyond the dam on the southeast side of the lake. Water-pipes along the road leading from the reservoir toward Menlo Park had been pulled apart. The buildings in the neighborhood of the reservoir are of frame, and no great damage was done to them, except that the brick chimneys were thrown down.

*Redwood* (R. V. Anderson). — The intensity of the earthquake in Redwood City was about IX. Many buildings were partially wrecked and the new court-house was completely ruined. Over 40 houses in the town were moved upon their foundations and a majority of the houses had the plaster badly cracked. Ninety-four per cent of the chimneys fell, and dishes and similar objects were universally thrown down. Along the two roads leading from Redwood to Portola, out of 23 big public water-tank\* U) were thrown down.

*East of Palo Alto* (S. Taber). — On the Embarcadero road, from the railroad crossing at Palo Alto toward the Bay of San Francisco, only about half the brick chimneys had been thrown down. Plaster on first-floor walls cracked, but it was not injured to any extent in the upper stories. Many houses showed little damage to plaster, even on the first floor. The tanks of the Palo Alto Water Company (at 1, map No. 22) had not been thrown over, but the frame (100 feet high) had slipt on the concrete foundation a maximum distance of about 0.5 inch in a direction N. 87° E. The water is reported to have slopt out of the reservoir on the east side. A water-tank about 0.5 mile nearer the bay (at 2, map No. 22) was standing, as was a brick chimney near it. Damage to houses in this section was directly due to high brick chimneys; plaster was sometimes scarcely cracked, even on the first floor of houses thus damaged.

*Mayfield to Guth Landing* (R. L. Motz). — In the town of Mayfield most of the houses are small, 1-story buildings resting on wooden foundations, and many of the chimneys were of terra cotta and wired to the roofs. Out of a total of 258 chimneys 183 fell — about 70 per cent. A few brick buildings were badly cracked, and the fire-walls were all thrown off. The plaster in the small buildings was somewhat cracked, while in the larger buildings the damage done to plaster was more marked. The concrete bridge over Madera Creek, on the county road 0.5 mile southeast of Mayfield, was not cracked. A half mile further southeast along the road, 2 water-tanks and 3 chimneys (2 brick and 1 cobble-stones and lately built) were standing. A short distance nearer Mountain View Landing there were fallen or damaged chimneys (at 4 and 5, map No. 22).

At Guth Landing a large brick warehouse facing N. 87° E. had its sides cracked, lost a few bricks at the top, and had the upper part of its east and west ends knocked out. From Guth Landing southward along the road into Mountain View, the effects were uniform; chimneys were down with two exceptions, there was little or no damage to plaster, and the flow from bored wells had increased. In one case a wind-mill (at 6, map No. 22), which had been in use for years to pump water from the well, was no longer found necessary, but the artesian water was muddy.

*Mountain View* (H. P. Gage). — On the county road between Mayfield and Mountain View, concrete bridges were uninjured, water-tanks were left standing, and the smaller or more solidly built chimneys uninjured.

(R. L. Motz.)—In the new town of Mountain View, built mostly in the vicinity of the railway station, 6 brick structures, including the Pacific Press and the cannery buildings, were seriously injured. Out of 271 chimneys, 206, or 76 per cent, fell; out of 46 large water-tanks 20, or 43 per cent, fell. In the Mountain View Cemetery there were 26 large monuments; of these 11 fell and 7 were shifted, while 13 slab headstones out of 27 were thrown down. In the village of Old Mountain View 75 per cent of the chimneys (31 out of 41) fell, and 33-J per cent of the water-tanks (3 out of 9) fell.

(H. P. Gage.)—On the road leading southwest toward San Antonio Creek from the town of Mountain View, the houses showed no uniform damage. At one place south of the county road and two miles west of the Mountain View Station, the water-tank swayed and threw out several barrels of water during the shock, yet the plaster in the house was unhurt and only a few dishes were broken. At the next house, the chimney fell.

At the Weeks poultry ranch 2 chimneys fell, dishes were broken and plaster was cracked; but the water-tank was uninjured.

Two and a half miles southwest of Mountain View Station, beside the road running up San Antonio Creek, a water-tank was so badly wrenched that it had to be braced to keep it from falling; another tank, on a side hill west of San Antonio Creek, had collapsed. The house near the latter, in course of construction, lost an outside chimney. Following the road up San Antonio Creek on its southeast side, another house between the road and the creek had one chimney cracked and another thrown down; plaster had

fallen in the second story, and sewer and underground pipes were broken. Much damage was also done to the houses on the hill southwest of where this road crosses San Antonio Creek. In one of these 3-story houses, the plaster was partly off the first floor walls, and windows were broken. The second house was so shaken that it shifted several inches upon its foundations. A 1-story cottage close by was little damaged; and in the pumping shed, bottles, cans, etc., standing on a narrow shelf did not even fall down. The chimneys were thrown down on the ranch house at Hidden Villa, two miles northwest of Black Mountain Triangulation Station, but there was no great damage otherwise. Big blocks of rock are said to have been shaken loose from the mountain and to have rolled down the slopes. One of these rolled into the chicken-house, and others broke the water-pipes at several places farther up the gorge.

On the road running southwest from Mountain View Station toward San Antonio Creek and 1.75 miles southwest of the station, a water-tank 8 feet high was thrown down. In the village of Mountain View, 0.5 mile southwest of the railway station, one chimney on a small house, and projecting 5 feet above the roof, was left standing; while another chimney on the same house was thrown down. On the road leading north from Mountain View, and 0.25 mile from the station, one chimney fell; but another, 1 x 2 x 3 feet was standing. The latter was braced with iron bolts, however. The plaster in the house was cracked, though not very badly, and the foundations were unhurt.

At the Ynigo ranch, 3 miles northeast of Mountain View Station, the house is large and old. Here the chimneys fell, one going down through the roof. The plaster was only slightly cracked. Frail sheds and water-tanks 20 feet high on light supports were not thrown down, and plumbing in the house was apparently undisturbed. There was an artesian well at this place which had, before the shock, flowed only slightly or not at all, and a wind-mill was used to raise the water. After the shock, it was found that the casing had been shoved up 2 feet, damaging the pump. The flow of water was increased and black sand was brought up. Another well at this ranch was unaffected.

At Jagel Landing there was but little damage. One chimney was unhurt, and another was slightly twisted.

The concrete bridges over Permanente and San Francisquito Creeks showed no new cracks. In the low lands northeast of Mountain View, all the chimneys except one at the Mascot Gun Club preserve had been thrown down, and water-tanks had fallen except where they had been especially well braced. The same was true in the vicinity of Sunnyvale. Between Sunnyvale and Lawrence a brick winery was destroyed, and a tank and wind-mill were thrown to the ground. On the second east-and-west road directly south of Sunnyvale, for a short distance toward Stevens Creek, a few chimneys were left standing; but the damage was generally uniform as reported above.

(F. Lane.)—A 3-story brick wine distillery in the northeast corner of the San Antonio grant, 3.5 miles south of Mountain View Station, was totally destroyed by the shock. This building was on the side of a hill. A 3-story frame house near it lost its chimney and was tipped to one side. A half-mile south of the winery, a water-tank beside the road had been destroyed. At the southeast corner of the same grant, a 2-story frame house (Selling's) was thrown from its 4-foot brick foundation and badly damaged. The road in front of the house was cracked, but probably on account of the steep slope below the road. South of the house, across Stevens Creek, there was a landslide 100 feet in width on the steep face of a bluff.

(S. Taber.)—The concrete bridge over Stevens Creek on the county road below Mountain View was not cracked, but at the brick yard, at the junction of the San Jose road with the road to Jagel Landing, a high chimney and a pile of brick had fallen over.

*Saratoga to Congress Springs* (F. Lane). — At Saratoga some chimneys were knocked off, but among those standing was a high chimney built on the side of a 1-story house. A wind-mill with a large tank had not been injured and no other damage was apparent.

On the Azule Springs road, all the 1-story buildings appeared to be in good condition, and few effects of the shock were noticeable. Near the place where five roads fork, one mile north of Azule Springs on the road running southeast from the forks, there was a 6-foot drop on the road caused by a section sinking in a solid piece on a long slope, without much disturbance in its vicinity. At the cross-roads halfway between Saratoga and West Side, the Lincoln school-house, on wooden supports, was thrown from its foundation and badly damaged. The tank behind the school-house was standing, as were all the tanks on the road from Saratoga to West Side except the one nearest the latter village. Only one more effect of the shock was noted in this vicinity; namely, the bridge over Stevens Creek, on the road running due east and west from West Side, was rendered unsafe for horses by being shoved a foot out of place.

On the Stevens Creek road, just after leaving the Saratoga road, one house near the junction of the two roads was shaken and dishes were broken, but the brick chimney was intact. Near the house a crack 2 inches wide showed a downthrow of 2 inches on the west side. A vacant house at the next turn, 0.5 mile southeast of Stevens Creek, had lost its chimney and leaned with the slope of the hill. Near this house a large area of ground, extending for 150 feet, had been torn up in a direction of N. 3° W., and a slide formed which almost blocked the road.

At the Borger place on the Stevens Creek road, the chimney was shaken down; the house, which stands on a high but well-built stone foundation, was not damaged otherwise. Wine was spilt in the cellar by the force of the shock. Further northwest along this road other disturbances were noted with increasing frequency; small cracks cross the road due north and south.

On the northeast side of the creek, 0.25 mile south of the place where a road turns northeast from the Stevens Creek road to go up Monte Bello ridge, there was a large landslide about 0.5 mile long and terraced from the top of the mountain.

The short road which runs northwest along Stevens Creek for a couple of miles beyond the junction with the cross-road which connects with the Monte Bello ridge showed an exposure of serpentine with cracks running along it N. 3° W. The cracks at the widest point measured about one foot. In the serpentine area the ground was badly broken up, and in one place it was covered with 3 feet of water. (Observation made April 22-23.) Following the road northwest beyond the terminus shown in the map, many cracks were seen, due to big landslides. Fallen trees have rendered the road impassable; boulders and dead trees still fell occasionally; even while the observer was there a large tree fell not 10 feet from him, loosening rocks and soil.

Just south of the two houses near the southern end of the cross-road leading toward the Monte Bello road from the Stevens Creek road, a break ran due east and west; it was 2 inches wide with a downthrow of 0.25 inch on the west side. Only dishes were broken in the house, a 1-story frame structure without chimneys, tho it stands above the big slide which was just mentioned. Another crack 4 inches wide was found in the road above the house.

The village of Congress Springs had not been shaken very badly. All water-pipes and tanks were intact and very little timber seemed to have fallen. The car tracks on the curve near the path to the spring had been thrown over toward the bank for about 20 feet of the curve, a 4-inch displacement resulting. The 2-story stone building of the Saratoga Wine Company was partially thrown down, and the side nearest the road had to be propped up to keep it from falling. At this point several cracks were noticed in the loose alluvial material of the road, almost at right angles to each other.

*Stanford University to Portola and Woodside* (S. Taber). — Going southwest from Stanford University along the road leading up San Francisquito Creek (at 8, map No. 22), on the banks of the creek many dead limbs were broken from trees, and a dead oak

2 feet in diameter was broken off about 20 feet from the ground. But little damage was done at a house a short distance farther west. On the north side of the creek (at 9, map No. 22), the 12-inch cast-iron pipe of the Stanford University water-main, buried about 3 feet deep, was cracked, allowing the water to spurt 20 feet into the air.

Beside the road just west of Searsville reservoir, a living white oak 6 feet in diameter was uprooted by the jerk of the earthquake shock. (Plate 106A.) At the Searsville dam the waste way is 45 feet wide. The water running over the spillway was 4 inches deep before the earthquake, but afterward it increased to 5 inches; more water was also noticed in the creek that empties into the lake.

The Preston residence, about 0.5 mile south of Searsville Lake, lost its chimneys. Along the road leading from Searsville Lake southeast thru Portola, the water-tanks were all thrown down, except one near the junction of the Portola road with the Alpine road.

The bridge at the north end of the village of Portola had the ends thrust together so that the planks forming its floor were thrown out of place. In Portola, brick chimneys were all down and water-pipes were broken. The Portola store was thrown off its foundation. The Catholic Church in the village is a frame building that stood upon an underpinning of posts about 3 feet high. This building was thrown bodily about 2 feet toward the north, apparently thrust over by the underpinning when it gave way. The Portola school-house was also thrown from its foundation, which was about 3 feet above the ground. Two small dwelling-houses southeast of the school-house and on the south side of the road were thrown from their foundations.

Following the Portola road from Portola toward Woodside, the houses showed considerable damage, with chimneys down. The water-tank at the fork of the road in front of Mr. Preston's house was thrown down, and the big tank at the fork of the road, at the site of the old village of Searsville, was also thrown down. The white oaks in the field north of the road had also many large branches broken off by the shock. A shanty between the 2 bridges (at 11, map No. 22) was down flat; and in a few cases the underpinning of houses had given way, the houses having settled in consequence. Small trees were overturned and fences broken. A large live oak had its top broken off about 20 feet from the ground (at 12, map No. 22); at the place of fracture the tree is about 3 feet in diameter.

Taking the western road past Newman's, which is at the place where this road crosses Bear Creek, from Searsville Lake to Woodside, two especially well-built water-tanks beside the road, tho well shaken on their foundations, did not fall. On the south side of the road, about 0.25 mile southeast of Mr. Folger's, a large live oak was torn up by the roots (plate 106B), while several eucalyptus trees had branches jerked off. A strongly built 1-story house just below (13, map No. 22), and within 400 feet of the fault-line, lost all of its chimneys, but the plaster was only slightly cracked. Beds and other furniture in the house were jerked in directions parallel to the fault-line. A small bed standing in the northwest corner of a room was not moved, but a larger bed near the center of the same room was moved several feet. A water-tank a short distance northwest of the house, new and strongly built, about 15 feet above the ground, had nearly all of the water spilt out of it. An eye-witness says that the water was thrown high up on the northwest and southeast sides. The water-pipe running from the house to the pump was bent in a curve toward the northwest, and where it entered the pump-house, the boards were broken on the southeast side of the pipe. The other pipe (also 4 inches in diameter) had the threads stripped off at a joint, and the ends of the pipe pulled apart for a distance of 2.5 to 3 inches. The pipe was new and buried a few inches below the surface of the ground. A large oak tree standing 200 feet or so from the house had large limbs broken off by the shock. At the Folger place, between Newman's and Portola, the chimneys were all thrown down.

On the west side of Bear Creek and north of the road along the foot of the mountain near Woodside, a 1-story sandstone house had its south wall thrown down, and was otherwise badly damaged. About 50 feet of stone wall, laid with mortar, along the side of the road, 3 feet high and 1.5 feet wide, was thrown down. A tank at the cross-roads in Woodside was left standing. The upper part of a brick winery 1½ stories high (at 26, map No. 22) was demolished, the roof being split down the middle and smashed to pieces. A house 1½ stories high (at 14, map No. 22) was thrown toward the southeast, the underpinning giving way in front. The house was badly damaged. Water in a large tank near the house spilt out on the southeast and northwest sides.

At the very end of the short, crooked road mapped as running northwest from the village of Woodside, there was a well-built 1-story frame house, of which the brick chimney had been thrown down; the plaster of the house was only slightly cracked. Near this a large water-tank was thrown over; another remained standing but had the shingles knocked off the roof on the northwest side by the force of the water dashing up against it. The old adobe house at the cross-roads in the village of Woodside was thrown down, the posts and supports left standing leaned at a considerable angle toward the northwest.

A large frame house (Mr. Josselyn's residence), north of the road and close to West Union Creek, was demolished; while another on the opposite side of the road, and just south of the bridge, was not badly damaged. The concrete bridge over West Union Creek, 1 mile south of the point (14, map No. 22), showed a few small cracks. From this point on up King's Mountain road, as far as the summit, there were no cracks nor landslides.

*Page Mill and Alpine roads* (S. Taber).—All brick chimneys along the upper part of this road were thrown down. At the Clarita Winery crockery was broken and milk spilt from pans. On the road from Clarita Vineyard to the Allen place (at 18, map No. 22), several small cracks 0.25 to 0.5 inch across ran east and west; numerous cracks intersected (near 18, map No. 22) in various directions, while some large ones running parallel to the contour lines were probably due to earth slipping. Judge Allen's in the valley, and several smaller houses, were thrown from their foundations and otherwise badly damaged.

Following the Alpine road up Corde Madera Creek, cracks were common on the outside or filled portion of the road, and these were generally parallel with the embankment. The steep southern slope of the ridge just north of the Alpine road, along its lower course, was favorable to landslips. At many places huge masses of rock had been thrown down from these steep bluffs into the road, completely blocking it up. On the south side of the creek the slopes were not favorable to landslips, but there were several of them; and at one point, about a mile from the summit of the ridge where this road enters the Page Mill road, one slide carried away the entire roadbed for a distance of about 300 feet.

(H. P. Gage.)—Following the Page Mill road westward from Black Mountain toward Langley Hill, a 1,000 gallon tank was undisturbed, but 3 live-oaks near by were uprooted, one of them being a large tree with a 12-foot base. These trees were in a rather dry soil, yet none of a grove of trees growing in moist soil was overturned. Farther west up the road which loops toward Langley Hill, a big crack running east and west, caused by a slide, showed a drop of 8 inches on the north side; and from here on down to the Alpine road the road was badly cut up with slides, but was not impassable. On the steep grade of Langley Hill a slide had moved 30 feet. At the ranch houses there was little damage done by the shaking save sometimes a fallen chimney or a few broken dishes. At one ranch the people reported that cows were much frightened during the shock.

(F. Lane.)—Along the ridge road southwest of Stevens Creek, separating Santa Clara and Santa Cruz Counties, there were some cracks due to landslides. Sandstone blocks, some of them 6 feet in diameter, had rolled down the hills toward the creek. People at the houses along this road stated that the shaking had been severe, with loss of a few

chimneys but very little destruction otherwise. No evidence of cracks could be found upon the side road. At a house situated at the junction of four roads about 3 miles west of Congress Springs, no damage was reported, tho the inhabitants were up at the beginning of the shake and say that it was accompanied by considerable rumbling and that the shocks which followed were preceded by a sound like a blast.<sup>1</sup>

*King's Mountain down Purisima Creek* (S. Taber). — At King's Mountain House, brick chimneys were knocked down and some dishes were broken, but no damage was done to the house. Cream was spilt from the milk pans on the southwest side. On the Cahill Ridge road leading northwest from King's along the crest of the ridge, little damage was noticeable. An old woodshed was thrown down (at 21, map No. 22), and about a mile farther on the top was broken from a large redwood tree about 75 or 100 feet from the ground (at 22, map No. 22).

Following the trail from King's Mountain House down Purisima Creek, a large slide on the northeast side of the creek had filled the road to a width of about 100 feet (at 23, map No. 22). The buildings at Hatch's Mill, just below (24, map No. 22) were not damaged, but a little farther down several cracks were found, one 8 inches wide and running S. 23° E. On the northeast side of the creek, just below Borden's Mill, a big slide had dammed the creek to a depth of 25 or 30 feet (at 25, map No. 22). The slide was between 0.25 and 0.5 mile long. The buildings at the mill showed no damage, but a bridge just above the mill was crushed by a slide from the south side of the creek.

*Bear Creek* (H. P. Gage). — Between Redwood City and Woodside, all of the public water-tanks were thrown down or had to be rebuilt. On the Bear Creek road, southwest of Woodside, there were many cracks caused by landslips down steep banks. The tops of 2 partly decayed trees, one a redwood and the other a spruce, had been broken off where the diameter was 2 feet. Near where the first trail branches to the right from this road, an old oven built of clay and stone, 4 feet high, was cracked, and an old barn was badly damaged. At the point where the road itself becomes a trail there is a log cabin, probably used as a summer camp. This cabin was locked and had apparently remained undisturbed since the earthquake. The floor is about 6 feet above the level of the ground. Table, benches, chairs, and all the bottles and utensils, except a coffee pot, were overturned. The table was solidly built and measured 4 by 8 feet. About a mile east of this cabin, at the end of another trail, was a 1-story frame house; a bed on the first floor was moved by the shock 8 feet to the middle of the room, tables and chairs were displaced, and dishes were broken. A house and dairy between this place and the road were moved on their foundations, and water was spilt out of pails from northeast to southwest. Tops of spruce trees were broken by the shock. Four miles farther southwest, along the trail toward the San Gregorio road, people reported that all the stoves on the first floor of their houses were overturned during the earthquake, with the exception of a kitchen range which was twisted around 6 inches. Their dishes were also broken. Just south of the junction of this trail with the San Gregorio road, a 2-story house had been shifted on its underpinning and some plaster was broken. A water-tank 20 feet high fell at this point.

*Half Moon Bay, Purisima and San Gregorio* (S. Taber). — Following the road along Pilarcitos Creek toward Half Moon Bay, many cracks and slides were found on the ocean side of the ridge, but few on the east side. All of these seemed due to slipping of the earth. At one place there had been such a large slide that big blocks of sandstone had fallen down into the road. Here and there along the road big cracks had opened, parallel with the road and the creek where the slope is very steep, and promising to make the road impassable by landslides, should a heavy rain come.

---

<sup>1</sup> Mr. Lane adds: "While I was there, however, we had a slight shock and I noticed neither blast nor noise."

Just north of the bridge over Pilarcitos Creek, north of the town of Half Moon Bay, an adobe house west of the road was thrown down by the earthquake, killing 3 people (at 30, map No. 22). The concrete bridge was badly cracked, as were the approaches at both ends. Just south of the bridge, several small cracks in the low ground west of the road permitted water to spout up, bringing sand with it. In the town of Half Moon Bay many buildings were badly damaged, some old frame houses and the brick bank building being flat, while the upper half of a 2-story brick structure was demolished. The Mosconi Hotel, a 2-story frame building, had plaster shaken from the side walls of the first floor only, while the ceilings of these rooms were not cracked.

In Half Moon Bay it was reported that there was no evidence of any change of level along the coast. The streams on the west side of the mountains were said to have doubled in volume. The road along the coast from Half Moon Bay to San Gregorio showed comparatively few traces of the earthquake. The concrete bridge over Canada Verde (at 31, map No. 22) was slightly cracked, and 0.5 mile farther south a water-tank lay flat across the road.

At Purisima the chimneys were all down, and crockery was broken. The intensity of the shock was apparently less at Purisima than at Half Moon Bay. According to various reports, a crack east of the road below Purisima, due to a landslide, extended for about 1,000 feet nearly north and south; and an earthslide on the side of a hill a mile or more farther south was about 100 yards long and 80 feet across.

At San Gregorio very little damage was done. The hotel lost only a little plaster and a few dishes. Turning eastward on the road along San Gregorio Creek, traces were found of increasing intensity. A mile from the town of San Gregorio, a water-tank 20 feet high was still standing, while a couple of miles farther east the creek was dammed up to a depth of 6 feet by a slide from its southeast bank (at 32, map No. 22), and all chimneys were down. Miss L. E. Bell reports that near Bellville a small alkali flat was raised about 3 feet. There was a landslide into the road for a distance of 300 feet, the height of the slide being 100 feet (34, map No. 22). Chimneys and tanks all thru the valley were thrown down.

(G. A. Waring.)—Of the 2 stores at San Gregorio, the one in the bottom-land suffered most, nearly all the shelf goods being thrown down. Cracks from 12 to 18 inches wide appeared in the cultivated bottom-land, and a water-tank was shifted on its platform 8 inches northward. In the Lobitos saloon a slot machine was hurled to the floor, and nearly all the bottles on a shelf running east and west were thrown off. Small cracks appeared in the ground at Lobitos, and a small slide occurred in the road 0.25 mile up the stream.

*La Honda* (H. P. Gage).—The inhabitants say that after the shock the creek rose about 4 inches and became muddy. At the hotel, plaster fell from first floor walls; the rest were little damaged. The plaster had already been cracked, however, by raising the house. Lamps were all shaken off the tables, and all the chimneys were down. Water spilt from the horse-trough in a northeast-southwest direction.

Near the Weeks ranch house, between La Honda and the summit of the ridge on the road leading to Redwood, an inconspicuous crack was noticed running east. It was about 2 inches wide, with no vertical movement evident. The north side of the crack, however, had moved fully 3 feet eastward. The crack simply marks a big slide which has been slipping for years, and which descended 3 feet during the earthquake. The Weeks house, a strongly-built frame structure, 2| stories high, was badly damaged. A large outside chimney fell thru the roof to the first floor, and the plaster was fairly stripped from the lower rooms and somewhat cracked upstairs. The sliding doors downstairs were shaken off their tracks, several windows were broken, the front door was cracked, and many of the door jambs were broken. The heavily built barn near the house was



badly strained. The water in the reservoir was spilt from northeast to southwest. In an old house near the summit the stove was not moved at all, but the chimney built 40 years ago fell.

(S. Taber.)—For some distance on the west side of the summit sandstone blocks had been cracked off and scattered across the road. From the summit of the ridge to the Portola Valley, the only effects noted were the wreck of a ramshackle old barn and a 3-inch crack across the road (at 36, map No. 22), probably due to settling.

*Congress Springs to Boulder Creek* (B. Bryan). — From Congress Springs, following the road that passes along the valley, about a mile east of the Castle Rock Ridge, in a southeasterly direction toward the reservoir of the San Jose Water Company, evidences were found that the earthquake had an intensity of over IX. The walls of a stone barn had been thrown down, 1,000-gallon wine-tanks in a cellar had been shifted, and people in the houses were thrown down while trying to get outdoors at the time of the shock. In a house close by, at the south end of the dam, the first floor plaster fell. Poorly built foundations fell. Southeast of the reservoir the chimneys and water-tanks were down. Two water-tanks at and near the bend of the road (at 37, map No. 22), were standing, but 0.5 mile northwest of this place a water-tank had fallen. The water in the reservoir (at 38, map No. 22) had overflowed the 3-foot banks, but the water-tanks were standing. A short distance down the road, to the northeast of the reservoir, another tank was standing. A house 0.75 mile east of this reservoir was badly shaken, with loss of plaster and chimney. In the section a mile east of the fault-line (at 39, map No. 22) the shock was weaker. All the chimneys on cottages were standing as far as could be seen, as well as all the water-tanks. The bridges 0.5 mile southeast of the reservoir were considerably shaken. Cracks seemingly continuous in the direction of the fault-line ran thru the area 0.75 mile east of the fault-line. Two-story frame houses along the fault line 1 mile southeast of the reservoir mentioned were so damaged within that people were living outdoors; yet the shake had not broken a 6-inch flag pole on a 2-story frame house. A large redwood tree had been shaken down (near 40, map No. 22); the house near it had its chimney fractured down to the fireplace, and the stove and piano were thrown across the room. The water-pipes here were badly displaced and broken. The intensity was greatly diminished, however, near 41, map No. 22; chimneys did not fall, tho fractured; clocks were stopt; little rock was thrown down from a vertical outside wall 15 feet high.

On Deer Creek a large landslide started from near Grizzly Rock and slid westward, but changed its direction 60° or more farther down toward the creek. The mill in the creek bottom below the slide was partly buried, and one man was killed. It is 500 feet from the mill in the gulch to the top, at the point where the slide started. The slide covered about 25 acres of ground, and destroyed a lot of virgin timber from 3 to 10 feet in diameter. The slide material, which is 300 feet deep, is composed of soil, clay, and shale.

The shock could not have been very strong at 42, map No. 22. The houses stand on posts 10 to 15 feet high, but were not moved noticeably. Furniture facing most nearly north and south was thrown down, but not when facing in other directions. The inhabitants were badly frightened and ran outdoors without waiting to dress. On Bear Creek (at 43, map No. 22) a smaller slide had moved a few hundred feet, buried a hut, and killed one man. According to reports of men in this region, only a minute elapsed after the beginning of the earthquake before the slide was over. Down in the valley no cracks or other evidence of violent disturbance could be seen.

Farther southwest down Bear Creek, about 1.5 miles from the village of Boulder Creek, were evidences of a less severe shock. A chimney on a 1-story house did not fall, tho the furniture in the house was thrown down. Trees were violently shaken. A mile northeast of Boulder Creek a chimney on a 2-story house was down, but no buildings were moved or broken.

In the town of Boulder Creek, all chimneys were down except those on some 1-story cottages; these were cracked, however. People generally ran out-of-doors, but were not as a rule very badly frightened; some even stayed inside until they had drest. Water-pipes were not broken, but some plaster had fallen, and plaster was cracked everywhere.

Mr. Bloom, owner of a sawmill at the edge of the Big Basin, reports that the shock was less severe in the Big Basin region than at Boulder Creek; that there were no landslides on the road between the two places; and that, tho he had been nearly to the summit on the day of the earthquake, he had seen only one crack where the earth had started to slide.

(R. Collom.)—At Boulder Creek, on the east side of the stream, a small hill of about 150 feet elevation rises rather abruptly. Its sides are thickly covered with small trees and brush. Near the top, a large portion of the surface soil had been shaken loose, and had slid to the level of the creek, carrying trees with it.

At Ben Lomond no fissures nor other such evidences of the earthquake were to be seen. Inquiry showed this condition to continue in the country about the town. Broken chimneys were the only evidence. The inhabitants of Ben Lomond report several slight shocks during the night of April 21-22, 1906.

(B. Bryan.)—Going north from the village of Boulder Creek along the San Lorenzo River, only small wooden houses were seen, all with chimneys standing. There were few evidences of the force of the shock, except fallen redwood trees. Three dead redwoods had been snapt off from 30 to 50 feet above the ground; and farther on two more were noticed, one having broken and the other having been uprooted. A man who was at the sawmill, 8 miles north of Boulder Creek, at the time of the earthquake, stated that a few trees were torn up by the roots. Cordwood had been thrown down in several instances along here. A small landslide had moved across the road (at 44, map No. 22), which 20 men spent one and a hah\* days clearing away. In the gulch the tops of a number of redwood trees had been broken off from 50 to 100 feet from the ground, the diameters at the point of fracture measuring from 10 to 14 inches. Up the road to the summit of Castle Rock Ridge no slides nor cracks were observed.

On Boulder Creek, coming southeast down the China Grade, the shock was strong, but apparently not so severe as along the San Lorenzo River. The people were badly frightened by the shaking, however. One man reported that no redwood trees fell and that only a few dead limbs were broken off. Near the junction of the first road leading from Boulder Creek into the Big Basin, an old landslide which covered about 2 or 3 acres, dating back to the previous winter, had been widened by the shock and its direction had changed. Only a couple of hundred yards farther down the road, some stacks of smooth split redwood logs (cordwood size) had not been shaken down.

A small earthslide had started (at 45, map No. 22), and a crack, perhaps due to the same slide, was noticed. For the next mile or so southeast, there was a considerable amount of cordwood along the road, none of which was disarranged by the shock; and no trees nor dead limbs had fallen. In the houses between this place (45, map No. 22) and the sawmill (at 46, map No. 22), the evidences of damage were more serious. At this first place visited no damage was done; people were awakened but did not get up; no trees nor limbs had fallen. At the next place, 1 mile southeast, people ran from the house during the shake and attempted to remove a sick man. Small objects were thrown down and a pendulum clock was stopt. At the house just southeast of the mill, the inside furniture was overturned, the stove moved, and the terra-cotta chimney split and fell; while branches were broken from redwood trees near the house. At the mill the same effects were noted, and others as well; tops of live trees, from 6 to 8 inches in diameter at the fracture, were broken off. From the point (46, map No. 22) down to the road leading to Bloom's Mill, 1 mile south of the point (45, map No. 22), the intensity seemed to have been less. A water-tank beside the road was quite unhurt-; houses were

not badly shaken; and only small objects—cooking utensils, etc.—were thrown down. At an old mill 2 miles southwest, however, a clock had been thrown upon the floor and broken at 5<sup>h</sup> 11<sup>m</sup> A.M. Half of the piled lumber had been disarranged, and the water-tank, built on a frame 15 feet high, was shaken so that it fell the next Monday night.

*Ben Lomond Mountain to the Coast* (B. Bryan).—At the junction of the Ben Lomond Mountain road (47, map No. 22), the house was empty, but there was no noticeable disturbance in the sheds or neighboring trees, tho a few hundred yards south a few dead limbs had been recently broken from the redwoods and one or two dead trees had fallen. Some other trees were so loosened at their roots that they have fallen since the earthquake. At the Ben Lomond Wine Company, a place 2 miles southeast of the junction of the roads (at 47, map No. 22), a well-built cottage had 2 tall chimneys still standing. People did not leave the house during the earthquake. Leaving the Boulder Creek road, and crossing Ben Lomond Mountain by the Eagle Rock road, the damage appears to consist largely of fallen chimneys. Small objects, such as fruit jars, china, etc., were thrown down, but only from shelves against north and south walls. People left their houses, but were not much alarmed.

No evidences of a violent shaking were to be found on the trail following southwest down Big Creek, either in trees or buildings, except where a small, half-decayed shack had been thrown out of plumb and a set of shelves overturned in another cabin. A table near these shelves was unremoved, and the bottles on top of it were standing. At the dam on Big Creek (at 48, map No. 22), no harm had been done, nor was any damage visible in 3 old shacks just below the dam. A half mile from this point cracks caused by slides were noticed on a very steep bank. Slight damage was done to the flume (at 49, map No. 22), which 3 men repaired in half a day. A few objects were thrown down in dwellings hereabouts. Near the junction of Scott and Big Creeks, a light terra-cotta chimney did not fall, but milk was spilt from pans at this place.

(H. W. Bell.)—At a house 1 mile southeast of the junction of the east and west forks of Waddell's Creek, a brick chimney was thrown down. Near a deserted mill at the north-end of Ben Lomond Mountain, a small landslide had carried trees and brush down to the creek, and tall trees had fallen along the road. At a new mill a short distance from the old one, about a mile northwest of Eagle Rock, it was reported that the shock was distinctly felt, but no damage was done. Dishes even stayed on the shelves. A steep bank beside the road showed small cracks, which could apparently have been easily made in the loose soil.

(G. A. Waring.)—At Swanton it was reported that a distinct noise, as of a team crossing a bridge to the northwest, had been heard preceding each shock. Dishes on a shelf running northeast and southwest were thrown off, while those on a shelf standing at right angles to these were unhurt.

(B. Bryan.)—At the school-house (50, map No. 22) the globes were overturned by the shock. The teacher said that she had heard from the people at the end of the trail just above, leading northwest toward Swanton, that the shaking had overturned only a few glasses, and that their pendulum, clock did not even stop. At the next place, 0.5 mile southeast of the school-house, no damage was done, and the inhabitants were not disturbed enough to run outdoors. In the little settlement at El Jarro Point, the shock was so light that a small chimney with a terra-cotta top, making a height of 7 feet above the roof, did not fall; nor were similar terra-cotta chimneys on 2-story buildings thrown down, tho projecting from 3 to 4 feet. Glasses and bottles remained on the shelves in a bar-room.

At the lime-kilns (51, map No. 22) the shock had apparently been more severe, for tho no cracks were found in the kilns themselves, people ran from houses, small objects were thrown to the floor, and piles of cordwood were overturned.

(G. A. Waring.)—At the San Vicente lime-quarry, the intensity was found to have been considerably higher in the bottom of the canyon. A cow in the yard could not keep her feet, men could not walk to the door of the cook-house, and milk and water were nearly all thrown from the pans and kettles. Little or no damage was done to the buildings or furnaces, and cordwood on the steep slopes was not thrown down.

At Coast there was little sign of destruction by the earthquake, and nothing could be learned. At Bonnie Doon, tho the shock was appreciable, no clocks were reported stopt and nothing was thrown from shelves.

(B. Bryan.)—On the road thru Bonnie Doon the shock was uniformly light; chimneys were unharmed, plaster was intact, clocks did not stop, and even the milk had not spilt from the pans. People did not run outdoors. A top-heavy and rickety pigeon-house did not fall over, tho shaken considerably.

Down Laguna Creek to Coast, and up the trail east of Coja Creek to the asphalt beds, similar effects were noted. Near the latter spot, however, the shock appeared to have been somewhat stronger; small objects had fallen, milk spilt, and even one chimney was thrown down, while people were frightened enough to get out of the buildings.

From the asphalt beds as far east as the point 52, map No. 22, the observer found no one to question; but the shake had been so moderate as to leave no visible signs except where some cordwood had broken its end-stakes and rolled down at the ends. At the houses just south of this point, chimneys and plaster of 2-story structures were not damaged; only lamp-chimneys and such articles fell and broke. It was reported that at one house in the valley fruit-cans had been thrown from shelves.

(R. Collom.)—At the Wilder dairy, on the Santa Cruz-Pescadero road, 2 miles west of Santa Cruz near Meder Creek, the damage done by the shock was in the form of broken chimneys and cracked plaster in the houses. On the road 0.5 mile west of the dairy, the force of the shock broke an 8-inch water main.

A general examination of the country along the coast, as opened up by the Pescadero stage road, shows the damage in these parts to be confined mostly to broken chimneys and cracked plaster in the houses. Only in the case of buildings with very poor foundations was any of the superstructure destroyed.

(G. A. Waring.)—At Wilder's dairy it was said that the shock seemed to come southward down the gulch, preceded by a rumbling from the same direction. Other places on the terrace-land near the shore west of Santa Cruz were not so badly shaken.

*Santa Cruz* (B. Bryan).—Entering the city of Santa Cruz from the west, the first chimneys down were only about 0.5 mile from the San Lorenzo River, increasing in number as one came into the town; yet many of the better-built chimneys, even on 2-story and 3-story buildings, were not thrown down. In the eastern part of Santa Cruz, some chimneys on both 1-story and 2-story houses fell, and some stood. In some cases plaster was cracked, but in no case where enquiry was made had much fallen. Some small objects fell in every instance.

(R. Collom.)—The shock was strong, but no lives were lost. The court-house roofs and towers were wrecked, many brick chimneys were down, and communication with other towns was entirely cut off by the breaking of telephone and telegraph wires. Many buildings had their walls shaken down.

At the north end of the bridge crossing the San Lorenzo River, at Third Street, there were 4 fissures running practically parallel and almost due east and west. These fissures are about 700 yards in length, and vary in width from 2 to 8 inches. They run thru an apple orchard and are in sandy soil, the softness of the land near the river-bed being apparently responsible for their presence. The river at this place runs about east.

In going thru the town of Santa Cruz in the direction of Boulder Creek, a fissure at the intersection of Bulkhead and River Streets was noticed. This fissure was about

1.5 inches wide and ran east and west. The 90-foot brick smoke-stack of the San Lorenzo tannery, which is about 18 feet in diameter at the base, was unharmed by the shock. It is said that as far as was observed, there was no change in the appearance of the sea-level at Santa Cruz; nor was there any damage done by the sea, nor any unusually large waves at the time of the shock.

At the Southern Pacific bridge, crossing the San Lorenzo River, there is a network of fissures varying from 2 to 15 inches in width, running thru the sandy soil. The direction of the main fissures is east and west, and they are on the south side of the river, which is nearest the bay. The ground has settled about 10 inches from the abutments and piers of the bridge. The depth of the fissures was indeterminable, as they had filled with sand. At Santa Cruz the inhabitants reported that near Olive Springs, 12 miles north of Santa Cruz, a landslide demolished Loma Prieta Mill and killed 9 men.

(G. A. Waring.)—The city of Santa Cruz furnishes excellent evidence of the effect of soil formation on the intensity of the earthquake shock. On the high ground in Garfield Park, and also in the northwest part of the city, only about one-fourth of the chimneys fell and a little plastering was cracked; while in the lower ground near the business section several brick and stone buildings were partly shaken down. The San Lorenzo River was churned into foam, the banks cracking and settling several inches; and sand, said to have come from a depth of 100 feet, was forced up in several places. The bed of the river is also said to have sunk several inches, and the current to be slower than before. A 6-inch water-main, running east and west across the river, at the covered bridge, was broken at each end of the bridge and moved 5.5 inches eastward. A man out of doors, facing south, was thrown east, then in the opposite direction. A eucalyptus grove south of him swayed violently east and west.

Along the beach the shock seems to have been less severe. The running engines of the power-plant at the Casino were unaffected. Things were thrown mostly from the west wall in a curio store on the beach. The wharfinger says he heard a rumble before the shock, coming from the southeastward; and saw the seismic wave traveling shoreward, causing a great rattling and crashing when it struck the town. Two distinct periods of vibration were felt, the latter being the harder. There was very little surf, the water looking like that in a tub when jarred. A safe in the wharf office rolled 3 feet eastward against the counter, then back again hard against the wall. The wharf, extending southeast, seemed to pitch lengthwise. Mr. W. R. Springer, jeweler, reports that out of 25 clocks repaired by him, which had been injured by the shock, 20 had their pendulums thrown off.

At the Santa Cruz light-house, a noise as of a wagon crossing a bridge preceded every quake. The motion seemed vertical as well as horizontal, for the glass globe over the lamp was jarred out and broken. In the curio-store at Vue de l'Eau, nothing on the lower floor was disturbed and only a few vases and pieces of bric-à-brac on the second floor were displaced. The shock seemed to come from the south. No effect on the surf was noticed.

(R. Collom.)—Going north from Santa Cruz, a small fissure ran northwest and southeast on the Boulder Creek road, about 0.75 mile northwest of the California Powder Works. Along the lower end of this road were several small and unimportant landslides. In general, the shock in this region does not seem to have been as severe as it was farther north.

*Road into Scott Valley* (B. Bryan). — Following the road from Santa Cruz into Scott Valley, at a summer hotel the chimneys were cracked all the way down, but were still standing; light objects on the first floor were moved, and bureaus on the second floor slid a foot or so. A 1-story frame house (at 53, map No. 22) was moved 4 feet or more, and a piano and other heavy objects were shoved across the room. The damage

to the house was so serious that it was being torn down at the time of observation. A 4,000-gallon tank (at 54, map No. 22) was moved and burst open, letting out 2,000 gallons of water. At the house nearest it, the chimneys were cracked, but nothing inside had been disturbed except some bottles, and no plaster was cracked. Houses in Scott Valley had about this same amount of damage; chimneys were sometimes cracked but were still standing, and plaster did not fall.

Miss Finette Locke, of Scott Valley, reports that a man was thrown to the ground by the shock, and when he arose could not walk because of the earth's motion. The vibration was northeast-southwest. Everybody was awakened; all clocks were stopt; plastering was extensively cracked; and all chimneys were broken. About a mile north some chimneys fell, and in one house 4 dozen jars of fruit were thrown from shelves. Landslides and cracks are reported between Scott Valley and Felton, and the dam across a small lake was cracked. A statuette and a vase fell to the northeast. The largest chimney moved 2 inches to the northeast. The entire width of the road to the southwest of the small lake was splasht with water thrown out of the lake. Long billows on the lake extended northwest and southeast. In an 8-foot trough orientated east and west water was caused to sway back and forth, but not parallel to the sides of the trough. A neighbor who was awake heard a roaring noise in the northeast. Much milk and cream was thrown out of pans.

Going from Scott Valley toward the town of Felton, the shock appeared to grow constantly lighter; some people did not even get out of bed.

*Felton.* — In this village the shock was apparently lighter than at either Boulder Creek or Ben Lomond. At Zayante, some cordwood and some finer split wood, piled 8 feet high, was not shaken down, tho some of it was said to have been disturbed.

(R. Collom.)—The shock was only moderately strong. The damage consisted of the destruction of brick chimneys. Earthquake effects at this point are shown only by the damage to artificial structures.

*Pescadero to Butano Creek* (H. W. Bell). — In the town of Pescadero the shock was heavy; all but 3 brick chimneys fell, and but few buildings were otherwise damaged. Plastering was knocked from the walls in most of the houses, and church bells were rung. All the water-tanks observed were still standing, and none of the churches had lost their steeples, tho one church was cracked open. Cracks were visible in the streets. One man walking eastward along the road near Pescadero was thrown flat on his chest by the first shock, but jumped up and braced himself in this direction, and was then thrown southward. Cracks in the road also appeared, and dust spurted up. Several people were nauseated by the motion and some said that a noise as of a wind preceded the shock.

Going eastward from Pescadero, a small crack 30 feet long, with an east and west strike, was observed. In an orchard near by there were several cracks, the widest one measuring 8 inches, with a vertical displacement of 1 foot. About 2 miles east of the town, on the north bank of Pescadero Creek, a landslide in the shape of a half-moon, its axis lying N. 23° W., had slipt down toward the bed of the stream. The greatest vertical displacement at the top of the slide was 15 feet; the distance from its apex to the road about 85 feet; and the span from end to end along the road about 220 feet. No solid rock was exposed by the slide. The road had dropt 6 feet at the south end, and 8 feet at the north. Only y few cracks appeared on the surface of the part which had slipt. The creek lying directly below the road had apparently received very little soil from the landslide.

Along the stretch of road between this slide and the town of Pescadero, there were few cracks in the road and the houses were in good condition. The only brick chimney seen was down. The intensity was apparently the same as in the village, and continued

the same along the road leading southeast toward Butano Creek. A 1-inch crack at the first fork of the road a mile from the town of Pescadero extended north and south for about 50 feet, and a farm house a mile farther down the road was nearly shaken off its foundations. Dishes fell from the shelves in this house, and water oozed out of level ground near by.

(G. A. Waring.)—On Butano Creek there were slight cracks in the road, and the streams were muddy. People said the shock was felt very distinctly, and dishes generally fell. The houses were all light, low buildings, and were not damaged. At a sawmill a mile east up this creek, there was no damage; and altho the banks beside the road showed traces of caving, there were only slight cracks, the longest one being in the middle of the road above the creek, running N. 67° E. for a distance of about 50 feet.

Along the main road from Butano Creek to Little Butano Creek, then across by trail to Pigeon Point, the same effects were noticed. Near a house on the level creek bed of Little Butano Creek, 4 cracks averaging 3 inches in width and about 20 feet in length ran N. 33° E. The only crack noticed along the trail toward the coast was 1 mile northwest of the place where Little Butano Creek turns from southwest to northwest, and was about the same length, but ran N. 3° W.

*Pomponio Creek road* (F. Lane). — On the Pomponio Creek road, chimneys were shaken but not destroyed. A big slide above the last house forced the observer to leave the road and take the trail, which rejoins the road a half mile farther on.

Four miles from the town of Pescadero, on the east side of a bridge over Pescadero Creek, the ground had sunk 2 inches and the aperture filled by the land sliding. A mile nearer the town, the road had dropt 5 feet, but had been filled by a big slide. A house at this point was quite intact, but the chicken-house near it was carried down and partly buried by the landslide. On Eues Creek, near its junction with Pescadero Creek, a hillside had started to slide and apparently needed only to become rain-soaked to continue the slipping. Wherever there were buildings in this region, no damage had been done except to chimneys, which had fallen.

*The Coast from Pigeon Point to Ano Nuevo Bay* (H. W. Bell). — At Pigeon Point the brick light-house, 125 feet high, showed a slight crack all the way around inside, about 40 feet from the ground. This crack did not look dangerous. Another crack 20 feet higher up dated from December 17, 1904, the keeper explained. The base of the pedestal holding the lens was slightly cracked, but the lens was intact. In the houses near the light-house the damage was slight; brick chimneys had not fallen, tho slightly cracked, and the same was true of plastering. A mile west of the light-house a few slight cracks, with a direction of N. 28° W., were observed.

Leaving the coast road at the fork halfway between Pigeon Point and Franklin Point, and going northeast along Gazos Creek, then southerly to the crossing of Whitehouse Creek, then back again to the ocean road near Franklin Point, few traces of the shock were noticeable. A small landslip, 0.25 mile up the east side of the short creek which flows into Gazos, just west of the fork of the road which continues northwestward to Little Butano Creek, showed a 2-foot vertical displacement at the top, and the land had shoved into the road below. This slide measured 150 feet from its top to the road, and its width at the road was 100 feet.

Along this route from Gazos to Whitehouse Creek, 0.125 mile from Whitehouse Creek, at several farm houses brick chimneys were down, houses slightly moved on their foundations, dishes broken, and plastering cracked. A half mile northeast of the mouth of Whitehouse Creek the same kind of disturbance was found. The intensity was apparently uniform with that at Pescadero. At the Cascade ranch, 0.25 mile northwest of Green-oaks Creek, the shock was oven stronger than on Whitehouse Creek. Cows were thrown off their feet, chimneys were down, the house cracked, and nearly all plastering fell off.

(H. W. Bell.)—It was reported here that along the Ocean Shore construction work near Bolsa Point, a concrete pipe 24 inches in diameter and 6 inches thick, embedded in clay, had been cracked by the shock. The keeper of the Ano Nuevo light-house says a distinct rumbling preceded the shock, which came at first rather gently, followed by a hard, confusing shake. A brick chimney in the house near by was cracked and twisted 0.75 inch out of place, but the new tile and concrete building was unhurt. The ocean became no rougher, but had a peculiar greenish hue for several days after the shock. At Pigeon Point the shock was less severe, and little damage was done to the buildings, altho cracks in the light-house, caused by a former quake, were opened somewhat wider.

Following the road from the Cascade Ranch across toward Ano Nuevo Bay, the intensity seems to have decreased. At a house 0.75 mile southeast of where the coast road crosses Greenoaks Creek, a few dishes fell; plastering was but slightly cracked, and a water-tank stood. Half a mile north of the mouth of Ano Nuevo Creek, the brick chimney was knocked from a house, plaster was cracked, and cattle were caused to stagger. Half a mile southeast of where the main road crosses Finney Creek, a ledge of shale had been knocked into the gulch. The largest piece which fell had an unbroken surface of about 4 square feet. The almost horizontal edges of shale beds near a house at this point were knocked down. A long, narrow landslide above a house 0.75 mile northeast of the mouth of Waddell Creek had landed against the end of the house, taking out a strip of earth below a spring and causing a good supply of water to issue forth. This slide appeared to be partly due to the large amount of water present. At the house the chimney was cracked, but dishes did not fall from their places.

Turning north by a trail opposite Greyhound Rock, evidences of about the same intensity were found. Dead trees had fallen here and there, but in no uniform direction.

#### LOS GATOS TO SAN JUAN.

*Los Gatos, Santa Clara County* (I. H. Snyder).—Los Gatos, population 1,900, is partly on a mountain slope and foot-hills, and partly on river deposit. It is surrounded by hills on three sides. Los Gatos Creek runs thru the center of the town from south to north. The earthquake shock was violent, but apparently not so severe as in the central portion of the valley. Nearly all business houses were damaged, and about one-third of the plate glass fronts were broken. Much plaster fell both in Los Gatos and in the surrounding country. Chimneys fell in many different directions, and nearly half of the damaged chimneys left standing were twisted. About 80 per cent of all the chimneys were destroyed or damaged. Brick fronts were nearly all cracked, and one fell out. There were about a dozen upheavals of sidewalks, mostly on north and south streets. Grocers and druggists lost quite heavily in breakable goods.

The direction of the shock seemed to be in general north and south, altho there were certainly severe vibrations from nearly all points of the compass, while some persons are certain that there was a vertical motion, especially near the beginning. After the shock was over, our chandelier was still swinging violently north and south; a near neighbor's lamp swung in the same way; another hanging lamp 0.5 mile west swung northeast and southwest. East and west shelving in stores suffered rather the most, tho a store in East Los Gatos, with shelves north and south, suffered fully as much as any.

Of the 3 pianos seen in Los Gatos that were moved, 2 went to the south about 3 feet and one moved east the same distance. A small seismograph made several years ago was in working order, but there was no record, the needle having been thrown off by the extreme movement.

Mr. Lund, of Los Gatos, was one of the few people outside when the shock came. He is positive the premonitory roar came from the south and traveled to the north.



Mr. Dan Pickering, living about a mile south of Santa Clara, on the Santa Clara and Los Gatos road, was standing outside his barn when he heard the sound, which he compares to a stampede of cattle coming from the southeast. His tank and wind-mill fell diagonally across the foundation to the northwest, after swaying heavily three times; first to the northwest, then to the southeast, and finally to the northwest. He states that the ground rose and fell in waves a foot high. Others report that the orchards seemed to be agitated by a wave-like motion.

On the ranch of Dr. Tevis, about a mile from Alma Station, where the land is rolling and wooded, the ground was fissured and the bottom of an artificial lake was upheaved. (Plate 139c, D.) The cracks and fissures, of which there are many, run mostly north and south, and vary in length up to 100 feet, and in width from 0.5 inch or less to 20 inches. While a good many of the openings were parallel to the slopes and were caused by the ground starting to slide, others crost the roads and could be traced some distance up the banks. A board fence was splintered where it crost a fissure. The upheaval of the lake was caused by a closing together of the sides, shown by the heaving up of parts of the retaining dam at the lower end of the lake. The rise of the bottom is roughly 10 feet.

Three of the large cemeteries of the Santa Clara Valley were visited. In the Los Gatos Cemetery, on the New Almaden road, no monuments were thrown. In the Protestant Cemetery, 0.75 mile southwest of Santa Clara, 31 monuments were thrown down and mostly broken. Of these 10 fell to the south. In the Catholic Cemetery, 0.25 mile nearer Santa Clara, 26 monuments fell, of which 10 fell to the south. The direction of the fall of monuments in these two cemeteries is here tabulated:

	N.	NE.	E.	SE.	S.	SW.	W.	NW.	Total
Protestant . . .	3		7 <sup>1</sup>	1	10	1	5	4	31
Catholic . . .	5	1	6	2	10	1	1		26

<sup>1</sup> Of these, 4 fell from pedestals which leaned to the east.

In the Catholic Cemetery three monuments were turned on their bases, two clockwise and one counter-clockwise.

The Santa Clara city water-tower, with large tanks on top, fell to the southwest.

(F. H. McCullogh.)—I was in bed in Los Gatos and was awakened by the shock, which seemed to be a violent but irregular shaking back and forth in a northeast-southwest direction, altho objects were overturned in an easterly or southeasterly direction. A double bed on a polished floor rolled 4 feet from its position. One heavy marble clock was thrown off its shelf. Ornaments and bric-a-brac were thrown down. Two tables were turned upside down. Plastering was cracked. Chimneys were cracked above roof, but not thrown. In the town I could hear of only one chimney which was uninjured; 90 per cent of all chimneys were thrown down. Water in a reservoir 30 feet in diameter and 10 feet deep was thrown out so as to lower the level of the water nearly 2 feet.

*Lexington* (H. R. Johnson).—At the Lexington saloon, 3 miles south of Los Gatos, very little damage was done.

At the Averill place, 1.5 miles west of Wright's Station, a water-tank was moved a foot toward the south. A piece of board several feet long, which was leaning against the tank-house before the shock, was said to have been found wedged between the bottom of the tank-house and the foundation. This would necessitate a lifting of the tank-house in a vertical direction on that side, which might have been accomplished by the tank-house rocking from side to side.

*Summit Hotel* (H. R. Johnson).—At Summit, a summer resort, the new hotel and several small cottages were all thrown toward the north. The main fault fracture is

about 500 feet northeast of the hotel, and a secondary crack close to it had a downthrow of from 5 to 7 feet on the north or downhill side. The crack was about 4 feet wide here, and the line of fracture was parallel with the direction of the ridge. The Summit school-house was dropt 4 feet downhill from its original position toward the northeast. In the vicinity of Summit several redwood trees were snapped off.

Just north of Wright's Station, on the west bank of Los Gatos Creek, there was a landslide 0.5 mile wide which had slid into the creek and dammed it. \* The top of this slide was near the Summit school-house and was close to the main fault-line. The Hotel de Redwood was destroyed by the shock.

*Wright Station* (Miss F. C. Beecher). — Miss Beecher's home is on Loma Prieta Avenue, on the county line, 1.5 miles in an air-line from Wright's Station. The house stands on a ridge at an elevation of 1,700 feet. There were 2 maxima in the shock, of about equal intensity. The movement in the first was from south-southwest to north-northeast. All light objects were thrown down. Furniture against south walls was thrown down or moved out; objects against other walls were not moved as much. A small square piano which stood a few inches from a northeast wall ran back against the wall to the north with sufficient violence to break a knob off one leg. It then moved back to its original position, then 5 inches west. Then the two legs to the north jumped 6 inches south. These movements were determined by the marks upon the floor. A wash-basin, and a pitcher full of water, in an upstairs room, were thrown south, and the basin was found with the pitcher standing in it, uninjured but empty. A table in the middle of the same room fell to the north. A piano in a neighboring house, a heavy upright, was moved across the room to the northeast.

All brick chimneys on the ridge fell, mostly to the north. Trees at the foot of the ridge were bent over to the north-northeast. Half a mile to the northwest of the house, a fissure 2 feet wide appeared, from which bad-smelling gas emanated. The fissure runs from north to south, and the earth was piled up on the west side from 2 to 4 feet high across the road. On Highland, a mile to the west, a fissure 5 feet wide was opened at an altitude of 2,500 feet. A building standing close to a fissure was entirely uninjured, while others a little farther off were wrecked and one collapsed. Most good buildings in a belt 0.5 mile west of the house were wrecked, while barns and shaky buildings stood. About 1.5 miles west, a house split open. Gulches appear to have been contracted, as the bridges crossing them show that they were squeezed. The banks of Burrell Creek appear to have approached each other, so that the creek has become very much narrowed. Water-pipes were broken and twisted, and filled with dirt. Water was thrown out of tanks, but the tanks were not overthrown.

During the shock the waves appeared to oscillate in a north and south direction at first. There were at least 26 shocks during the first 26 hours after the main shock.

*Burrell School* (H. R. Johnson). — Near the Burrell school-house, 1.5 miles southeast of Wright Station, a crack extends across the road by a blacksmith shop and shows a downthrow of 4 feet on the northeast. The blacksmith said there was a strong odor of sulfur for 5 or 10 minutes after the shock. A well near by has had sulfur in the water for a number of years.

*Morrell Ranch* (H. R. Johnson). — The Morrell ranch is located 1 mile south of Wright's Station and is on the line of the fault. The house itself was built exactly upon a fissure, which opened up under the house at the time of the earthquake. The house was completely wrecked, being torn in two pieces and thrown from its foundation. (Plate 107B.) There was an apparent downthrow upon the northeast side of the fault, as seen in the orchard; but under the house the vertical movement was not so apparent. An especially strongly constructed wine cellar built into the side hill had the upper portion thrown 3 feet northeast, directly away from the fault-line. After the shock this upper portion



A. Shortening of railroad track between Los Gatos and Santa Cruz. Oh Ai Wi



B. The MorwU house, near Wright Button. & A.W.

of the house was left resting upon the wine tuns, and not upon its original upright supports (fig. 56). The fence and road near the house were crost by the fault and showed an offset which indicated a relative movement of the southwest side toward the southeast (plate 64B). One fence was broken apart, but the other was merely bowed, due probably to the resistance and drag of soil occasioned by a well-packed roadbed. The fruit-tree rows which crost the fault-line at approximate right angles were put out of alinement.

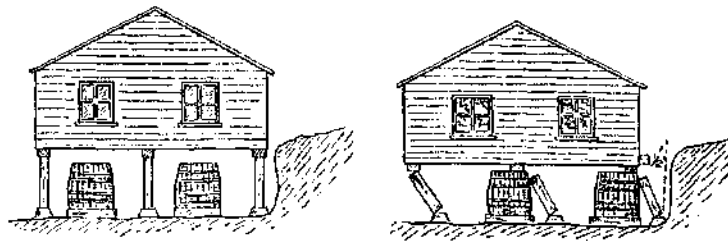
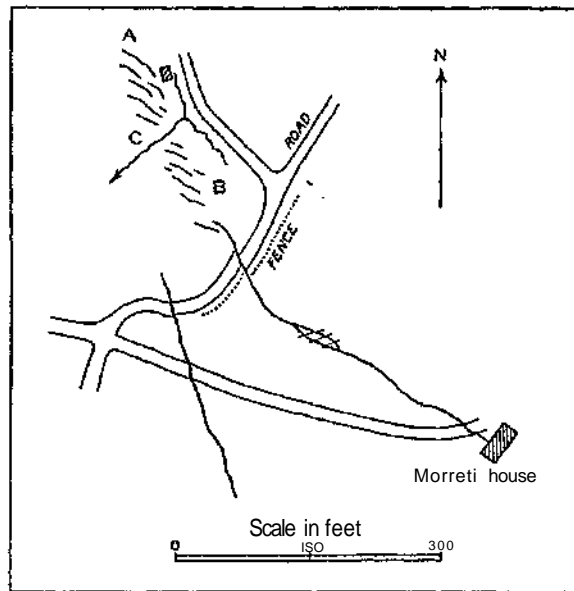

FIG. 56. — Section thru winery at Morrell ranch before and after the shock.

A feature associated with the movement of soil along the fault-line is shown in the accompanying sketch, fig. 57. The "splintering" of the main fracture raised a long, low ridge across which a creek had been forced to cut its way thru a vertical distance of 1.5 feet to get down to its original level.

Between Wright's and Alma the railway track was buckled. (See plate 107A.)

(D. S. Jordan.)—At Morrell's ranch, about 4 miles above Wright's, a large 2-story house with a wing stood on the slope of a hill. The east side of the house was much higher above the ground than the west, and stood on wooden piers about 7 feet high. The earthquake crack past thru this ranch, a branch of it going under the house. The main body of the house was thrown to the east, away from the crack, the ground there slumping several feet and the house being almost totally wrecked. All thru the orchard the rows of trees are shifted about 6 feet, those on the east side being farther north, and the east side, which is downhill, seems to have fallen. The crack is largely open and in one place is filled with water. This should be attributed to slumping. A little farther on, the crack passes thru a grassy hill on which there is no slumping. The Morrells say that this hill has been raised. What appears to be the fact is that the east side of the hill overrides the other. The whole top of the hill is more or less cracked for a width of about 10 feet. The east side is a little higher than the west side, and it looks as tho the hill had been shoved together and raised, the east side overriding. About 1 mile beyond Morrell's house, at the end of the ranch, there is a blacksmith shop, and the road is crost by the crack. Here there is a break of 3 or 4 feet like a waterfall, the east side being the lower; but this is part, I take it, of the general slumping of the east side of the crack



From U.S. Geological Survey, "Displacement on auxiliary crack, Morrell ranch."

where it stands near the ravine above Wright. Morrell's place is right over the Wright tunnel, the tunnel and the rocks near by being of finely broken rock and very much subject to slides and other breaks. At Freely's place, 4 or 5 miles north of Morrell's, some 15 acres of woodland have slid into Los Gatos Creek, making a large pond. There are many other slides in the neighborhood and many broken trees. Farther on, the crack goes into Hinkley's Gulch, in which the Loma Prieta Mills are situated, and which are buried under the slides. The slides which obliterated Fern Gulch at Skyland do not seem to have come from the crack, but seem to lie to the west of the crack.

*About four miles, south of Wright Station* (Mr. L. E. Davidson). — I was camping in the Santa Cruz Mountains. My attention was first arrested by a slight rumbling noise; then the house trembled for 4 or 5 seconds, and this was followed by a heavy rolling motion almost east and west. A heavy trembling came again for several seconds, then the heavy shock that threw down the chimneys. Tables and even chairs were upset. This must have lasted about 4 seconds; it then gradually died away. The whole time must have been all of half a minute. During the day several slight shocks were felt; about 2<sup>h</sup> and 2<sup>h</sup> 30<sup>m</sup> P. M., two rather heavy shocks came.

The ridge on which we camped was full of cracks, ranging up to 2 and 3 feet in width, and in length from a few rods to 0.25 mile, all trending west of north to northwest. All chimneys on this ridge were thrown down; several houses were completely wrecked; branches were broken from the trees, while many of the trees broke in two and others were uprooted. The canyon south of us was filled with landslides. In this canyon the stratification of the rocks is plainly shown. The strike is northwest-southeast and the dip is almost vertical. The cracks coincide in direction with the strike of the strata. Cold water was flowing from some of the cracks. I obtained a small bottle of crude oil from Mr. Sutton, which he said was dipt up from the ground on his neighbor's ranch, several hundred gallons of oil having run out of the ground since the earthquake, where there had been no sign of oil before.

*Skyland, Santa Cruz County* (T. Wightman). — Mr. Wightman's bed traveled across the room to the south, and he was under the impression that the house was falling to the south. Some houses in the neighborhood fell completely, and some collapsed on their foundations. The two chimneys of his house were thrown, one coming through the roof. Some pictures hanging on east walls were turned with their faces to the wall. Large landslides occurred in the neighborhood.

*Soquel, Santa Cruz County* (Miss M. E. Baker). — The house is on the first high bench above the stream in Soquel Valley, with high hills to the north and the east. At the first movement of the earthquake, chimneys were thrown to the south; at the second, mantel ornaments, books in the library, fruit jars in the pantry, etc., were thrown toward the north. Some houses in the vicinity had chimneys and objects partly turned around. There were two maxima in the shock, the first being the stronger, and the direction of movement was from north to south. In the second part of the shock the movement seemed to be a twisting one.

*Chittenden* (G. A. Waring). — At Chittenden Station evidence of a most violent disturbance was found. The cottage of the foreman was moved 5 inches westward; an upright piano was thrown northwestward upon its back, and electric drop-lights swung so as to break against the ceiling. A large frame dairy building on underpinning was moved 1/2 feet northward, as was a smaller building. The oil in a large tank was thrown southeastward, badly bending the tank and smashing the protecting shed. (See fig. 58.) The railroad office was not moved from its foundations, but the porch roof was jerked nearly off and a 1,000-pound safe was thrown southeastward upon its back. Three freight cars on the side-track, loaded with beans, were tipped over to the northeastward. At the time of the shock a north-bound freight train was running at

about 30 miles an hour, a short distance south of the bridge over the Pajaro. About 10 cars in the middle of the train were thrown off on both sides of the track. The track at the southern end of the Pajaro bridge sank from 2 to 4 feet for a distance of 150 yards, and between Chittenden and the bridge the track was bent in an S-shaped curve in several places. The concrete piers of the bridge were cracked, and the granite cappings shifted as before noticed. (See plate 65B and fig. 43.) There is much sulfur, oil, gas, and water in the hills here. A marked increase was noted in the flow of oil and water, and more gas and sulfur became associated with them. It is said that since the earthquake 16 years ago small shocks have been felt each spring, often severe enough to crack chimneys, and a deep well becomes muddy 2 or 3 days before these occur.

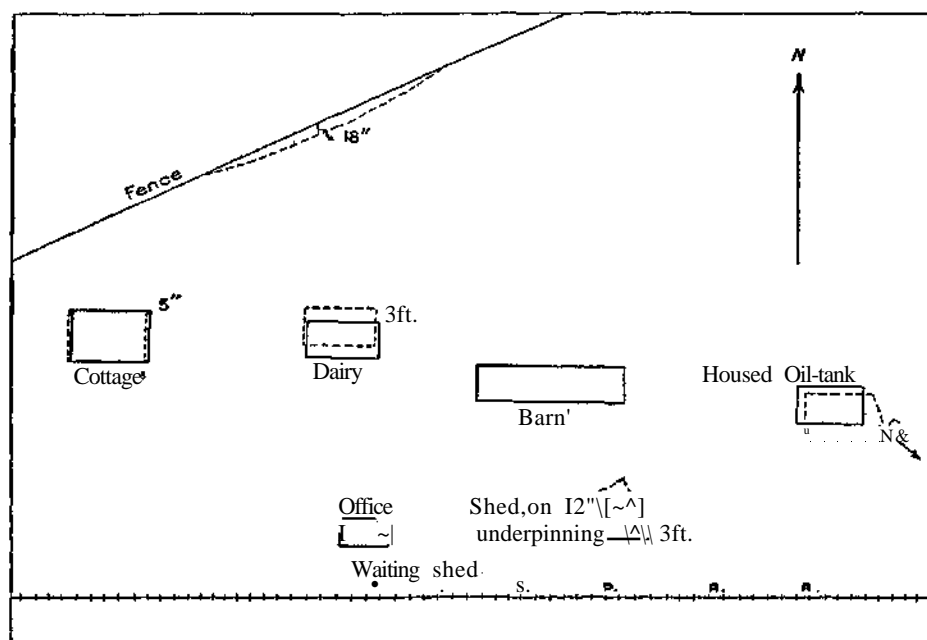

FIG. 48—Displacement of buildings at Chittenden

Fifty-two distinct shocks were felt during the day of April 18, and 32 that night. From 1 to 4 shocks were felt every day thereafter up to May 16, and from 2 to 5 occurred every night. Two miles north of San Juan, Mr. Canfield's house, at the foot of the hills 0.5 mile east of the fault, was moved bodily 2 inches westward, and the chimneys were completely thrown down; but a house 150 yards west of the fault, altho considerably shaken, appears to show the shock to have been less severe on that side.

*San Juan* (G. A. Waring).—The town largely escaped by virtue of being on solid ground. A large inner wall at the San Juan Mission fell, but it was no doubt weak, as other parts of the building appear unhurt. Only one or two chimneys in this village fell, but in the bottom-land between San Juan and Hollister the condition of the houses indicates a heavier shock on the low ground.

#### SANTA CLARA VALLEY.

Information regarding the distribution of intensity in Santa Clara Valley has been contributed by a number of observers whose names are given with the paragraphs dealing with the respective localities reported upon by them.

*Newark* (F. E. Matthes).—Nearly all brick and tile chimneys in the village were broken off; the direction of throw varied. Plaster cracked and fell in quantities on the lower floors of hotels and several other buildings. There are no brick houses in the town; and most of the frame dwellings showed no effects of the shock. At the depot the

water-tank fell, the supporting trestle being practically demolished. The track suffered a slight shifting in several places north of the village. Cracks opened in the ground in the vicinity of 2 small watercourses, but on a less extensive scale than that noted at Alvarado. Some of them cross the railroad track. In every case they emitted the same bluish sand (with the water) that had been found near the Alameda Sugar Mill. In one place, 1.5 miles northeast of the village, considerable water was still left standing in shallow ponds. According to neighboring ranchmen, these ponds had not existed prior to the earthquake.

*Centerville* (F. E. Matthes).—The amount of destruction here seems greater than in the neighboring towns, but this is in large measure due to the presence of a number of poorly constructed brick houses. All of these had suffered severely, the walls being in part thrown down. The bank building was more seriously damaged than most buildings, the walls being partly demolished and the roof having caved in. With very few exceptions all the brick and tile chimneys were broken off. Window panes broke in several stores. No cracks in the ground were found or reported. The direction of the shock was not agreed upon by the residents; according to some it was north-south, according to others east-west.

*Mission San Jose* (S. Ehrman).—Nearly all chimneys were thrown down, and plaster in houses cracked; the direction of the throw of chimneys and objects being chiefly from north to south. Some objects were rotated clockwise, and hanging objects were caused to swing.

*Irvington* (F. E. Matthes).—Destruction similar in degree to that at Centerville. Every brick house was more or less extensively damaged; portions of walls fell in some instances, and cracks in brickwork were common to all. The large brick and stone buildings of the Palmdale Winery suffered more severely than any, and large portions of them will have to be rebuilt entirely. Only a few chimneys were left standing in the village. Plaster cracked and fell in large flakes in several houses. The upper stories apparently suffered less than the lower floors.

*Milpitas* (F. E. Matthes).—Nearly all chimneys were here thrown down, a few, including a very short one on the depot, being left intact. There are no brick buildings in the village and the destruction seems insignificant. The hotel slept on its foundations, but was almost repaired at the time of the visit. A small adobe house in the southern part of the village was fairly demolished; it was known to be an old and weak structure. A water-tank and wind-mill were thrown down, support and all, about a mile south of town. They fell to the south. Another tank, north of town, appears to have fallen to the west. Several other tanks in this neighborhood were found intact. Of the two bridges over Coyote Creek, the northern one suffered some damage by displacement of end supports. It was unsafe to travel over at the time of the visit. The southern bridge was found intact, the end supports showing signs of but small movement.

*Agnews* (F. E. Matthes).—The insane asylum, consisting of three tall and three minor brick buildings and some small frame structures, suffered very severely. Every one of the brick structures was damaged beyond repair and will have to be entirely rebuilt. The main buildings were long, 3-story brick structures oriented north and south, with large projecting bay windows at their north and south ends. These were destroyed, so that both buildings are open at their ends. The fall of these walls caused the caving in of the roof, and the sagging down in some places of the floors. Numerous lives were lost; in all 112 dead being found in the ruins. The administration building was partly wrecked by the fall of its tower, which crashed thru the roof and all the floors, carrying with it a number of people. In nearly all cases the north and south facing walls were thrown out, while the east and west facing walls were, as a rule, better preserved. The shock seems to have been north-south principally, judging from these data.

The tall brick chimney of the engine house (100 feet high) broke off 20 feet above the ground and fell in a northeasterly direction, without touching any other structure. Frequently window-panes remained unbroken in the lower parts of walls whose upper parts had been completely demolished. (See plate 108A, B.)

The extent of the destruction is in some measure due to the use of weak mortar, the bricks having, as a rule, fallen separately rather than in aggregates. It is believed that well-built buildings would not have suffered such wholesale destruction as was witnessed here.

*Alviso to Milpitas* (G. F. Zoffman).—Evidences of the earthquake at Alviso are shown only by fallen chimneys and cornices and by cracked walls of the brick warehouses. No buildings were demolished and little serious damage of any kind was to be noted. From 1,500 to 2,000 feet west of the bridge over Coyote Creek, cracks cross the road in front of the Boot ranch-house, and several of them occur in the road leading to that house. (Plate 140B.) Some of these cracks are about 6 inches wide and have a general bearing of N. 43° W. Immediately after the earthquake, water flowed from some of them and brought up sand, which was heaped up about 6 inches high. The water ceased to flow after the second day.

Near the dwelling house on the Boot place, the ground settled 11 inches on the east side of the crack. The fissures past under the corner of the dwelling house and the building was partly thrown from its foundation. The cellar beneath it was filled with water to a depth of from 2 to 3 feet. There is a capped artesian well in the yard of this house, and about this well is a pool of water 12 feet across. The west side of the pool was lifted 1 foot higher than the east side, and fish were thrown out of the pool. A hundred feet east the fissures past under the barn, and the ground settled on the west side. Water flowed from cracks in the yard and piled up sand 6 inches high on both sides.

People living near Coyote Creek state that the water rose between 2 and 3 feet immediately after the earthquake; and up to April 26 the water in this stream had not returned to its normal level. At the bridge over Coyote Creek, on the Alviso-Milpitas road, the concrete abutments were thrust inward toward each other about 3 feet. A pile driven in the middle of the stream, which had been cut off below the water-level, was lifted about 2 feet and now rises above the water.

About 150 feet north of this bridge the banks of the stream cracked, the fissures running parallel with the channel and the land on the creek side sliding toward the stream. (Plate 140A.) West of the stream, in an adjoining field, water rising thru cracks built up many craterlets of sand. (Plate 143A.) Residents of the vicinity state that the water rose 3 or 4 inches above the tops of these craterlets while they were being formed, and that it ceased to flow toward the end of the second day after the earthquake.

In the road running northward along the west side of Coyote Creek from the bridge, many large cracks opened. Five hundred feet north of the bridge the cracks were 2.5 feet wide and 3 feet deep when the place was visited April 26. Farther north the cracks were very abundant, mostly parallel with the road, and some were 4 feet deep and 3 feet wide. A quarter of a mile north of the bridge, the whole road was shoved eastward into the channel of the creek, and with it a large number of willows and cottonwood trees that grew along the banks. Just south of this place the road was broken up badly for a distance of 300 feet. One of the largest cracks in the road was 5 feet wide, 6 feet deep, and more than 100 feet in length. The bearing of the fissures at this place was N. 23° W. For the most part the principal features were approximately parallel with Coyote Creek.

At Mrs. North Whitcomb's ranch, on the south side of the Alviso-Milpitas road, between Coyote Creek and Milpitas, the prune orchard was cracked and the ground shifted



at several places. The ranch-house, of concrete with a wooden upper story, was cracked across the northwest corner and settled slightly on the northwest side. In the back yard were fissures 1 foot wide, running about N. 13° W., with a downthrow of 1 foot on the east side. Some of the prune trees in the orchard are 2 feet out of alinement, and some as much as 6 feet. The lateral displacement here shows a relative movement of the south side toward the east. Considerable sand was brought up by water flowing from the cracks in this orchard.

In the town of Milpitas all the chimneys were thrown down, as well as 3 frame buildings. The hotel fell from its underpinning and sank bodily about 3 feet. The streets near it were not disturbed.

*Warm Springs* (G. F. Zoffman).—The Warm Springs Hotel, a large 2-story building, was but slightly damaged, only a little plaster falling. No buildings were damaged, beyond the falling of two chimneys.

*Milpitas-San Jose Road* (G. F. Zoffman).—About 0.5 mile south of Milpitas, on the Milpitas-San Jose road, cracks were formed across the road. They did not, however, appear to have any definite direction, and were so small that no lateral movement was discernible. At the County Alms House, about 1 mile south of Milpitas, two chimneys were thrown down and considerable plaster fell. On the north side of the bridge which crosses Coyote River, on the San Jose-Milpitas road, some cracks were found but they were evidently caused by the sliding of the banks. The bridge was not damaged.

The damage in the section of country lying between Milpitas and San Jose was nearly uniform. About 90 per cent of the chimneys were thrown down and in all houses that were plastered considerable plaster fell. Articles in the houses were thrown over, and much water and milk was spilt, altho it does not appear to have been in any particular direction. Cracks like those which were observed in the ground on the Milpitas-Alviso road reappeared on both sides of the Coyote River at intervals all the way to San Jose. Altho they occur in a general north-south direction, it seems probable that their origin was due to the unstable condition of the alluvial deposits which underlie the valley.

*Alum Rock Road* (G. F. Zoffman).—Starting from San Jose and going toward Alum Rock, it was observed that the shock had decreased from an intensity of IX at San Jose to an intensity of VI at Alum Rock. No cracks were found between Coyote Creek and the mountains, but in the valley at least 90 per cent of the chimneys were thrown. At the mouth of the Alum Rock canyon, a count of the fallen chimneys revealed the fact that the percentage had dropt to 50. At Alum Rock no chimneys were damaged nor had any movable objects been overturned, altho the water in sulfur baths had splasht up about a foot on both sides.

*Calaveras Valley to Evergreen and vicinity* (G. F. Zoffman).—Going from Milpitas toward the Calaveras Valley, chimneys were all thrown down on the flat lands between the village and the foot of the grade leading over the ridge to Calaveras Valley.

In Calaveras Valley all the brick chimneys were thrown down, tho there were only a few in this valley. No damage to houses is reported. Mr. Hadsell, in charge of the property of the Spring Valley Water Company, which has begun to construct a dam at the north end of the valley, states that there was no shifting of the strata in the tunnels, and that no damage had been done the property.

Between this place and the head of Alum Rock Canyon, the residents stated that cracks appeared across the road in several places; but altho this was in the proximity of the Calaveras Valley fault-line, which passes thru this region, it was not possible to verify their statements. Mr. Robert Ingleson, who lives in section 22, on the ridge east of Calaveras Valley, reports that the shock was not severe there. A long slender bottle standing on a table in his house fell over, but a lamp on the table was not upset.



A. Agnew's Insane Asylum, North end of female wards. P. E. K.

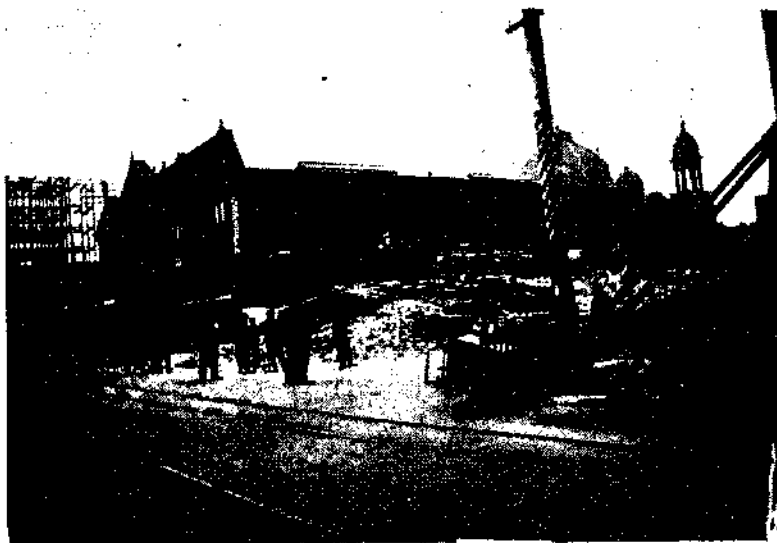

C. Phelan Building, San Jose.



B. Agnew's Insane Asylum, North side. F. E. M.



D. Hailef Ecoords, San Jose.



A. High-school, San Jose.



B. Hotel Temdbme, Aasex. Saa *J&m*>

Water in a horse-trough spilt out, and the trees waved as if there had been a wind. The earthquake consisted of two separate shocks, accompanied by a roaring sound that seemed to come from the north. Springs near his house became muddy after the shock and remained so for 2 or 3 days. The flow of the springs increased to about four times the usual amount.

Along the road down Penetencia Creek, a considerable amount of debris had slid into the road, in many places obstructing all travel except for pedestrians; but no evidence of cracks could be found.

In the region between Alum Rock and Evergreen, about 50 per cent of the chimneys were thrown down, but none of the buildings were materially damaged.

As the Santa Clara Valley was once more approached, the intensity of the shock perceptibly increased. At Evergreen, about 1.5 miles from the foot-hills, considerable damage was done; all the chimneys, all the road tanks, and nearly all of the wind-mills in the neighborhood fell. None of the houses were demolished, but some were shifted on their foundations.

(H. R. Johnson.)—The Pierce ranch-house, 3 miles southeast of Evergreen, was badly shaken; plaster and chimneys were down and much chinaware was broken. This house is on the gravel of the large alluvial cones which have been built out along the southwest face of the Monument Peak Range, where the stream debouches upon the plain. A water-tank fell northeast and southwest where the Tully road crosses the Coyote River 1.5 miles northeast of Oak Hill Cemetery.

At the Mayne ranch, 3 miles south of Oak Hill Cemetery, where the New Almaden Railroad crosses the Downer road, water from tanks and troughs was spilt in a north-west and southeast direction. To the west of the Mayne ranch, at the Downer ranch, a water-tank fell to the west. Mr. Downer said that milk in pans was spilt in the same direction.

At the Poncellet ranch-house, on Llagas Creek, 7 miles southwest of Madrone Station, only one chimney fell and no dishes were broken and no clocks stopt. This place is only 3.5 miles northeast of the fault-line and is situated directly upon rocks of the Franciscan series.

The Saunders ranch is 3.5 miles southwest of Madrone, on the Madrone road. The shock was quite heavy at this place; the chimneys were thrown down, dishes broken, and portions of what appeared to be quite solid and massive rock outcrops were thrown from the steep hills near the house. South of the Saunders place, 1.5 miles, a water-tank was thrown down.

*Santa Clara* (G. F. Zoffman).—Nearly all the brick chimneys were thrown down and most of the brick buildings were damaged. At Santa Clara College the rotary motion of objects was shown by the turning of statues in the chapel thru an angle of  $130^{\circ}$ . In the library of the same institution four marble statues, with square bases, fell in three different directions; one facing S.  $87^{\circ}$  W., another facing N.  $87^{\circ}$  E., fell toward each other, while the others, facing, respectively, N.  $3^{\circ}$  W., S.  $3^{\circ}$  E., fell N.  $3^{\circ}$  W. Professor Ricard, of the Science Department of the College, states that the vertical movement threw a wind-gage out of a socket a foot deep. This was the only evidence at the College of vertical motion.

*Cemeteries* (G. F. Zoffman). — A count was made of the number of tombstones thrown down in the Santa Clara Cemetery and the various directions in which they fell were noted. From these observations it seems that the shock was slightly more intense toward the easterly direction than toward the westerly. Twenty-five headstones were down and their respective directions of falling were, 3 N.  $17^{\circ}$  E.; 1 N.  $32^{\circ}$  E.; 1 N.  $37^{\circ}$  E.; 2 N.  $62^{\circ}$  E.; 1 N.  $77^{\circ}$  E.; 1 E.  $17^{\circ}$  S.; 1 S.  $58^{\circ}$  E.; 6 S.  $28^{\circ}$  E.; 3 S.  $23^{\circ}$  K; 1 S.  $3^{\circ}$  K; 1 S.  $37^{\circ}$  W.; 1 S.  $42^{\circ}$  W.; 1 N.  $88^{\circ}$  W.; 1 N.  $73^{\circ}$  W.; and 1 N.  $13^{\circ}$  W.

At Oak Hill Cemetery the larger percentage of tombstones fell in an easterly direction. Out of 34 monuments overthrown, 21 fell toward the east or nearly so; 6 toward the west or nearly so; and 1 toward the north or nearly so; 3 fell northeast, one fell northwest, 1 fell southeast, and 1 fell southwest. Out of 6 round monuments that were noted, 4 fell toward the east, 1 northwest, and 1 north. Since these could fall in one direction as quickly as another, it is evident that the greatest movement of the quake must have been toward the east at this particular place.

At the Catholic Cemetery, about halfway between San Jose and Alum Rock, only a few monuments were overturned; they fell as follows: 2 north, 3 south, 1 northwest, 2 east, 1 west, 1 southeast.

*San Jose* (G. F. Zoffman).—The earthquake threw down many brick and stone buildings (plates 108c, D, 109A, 110B, 111, 112, 113), and with the exception of 4 or 5, damaged all the rest of the brick buildings, more or less. (Plate 110A.) The damage done to frame houses was proportionately far less. Forty buildings were counted, however, that were thrown off their foundations and damaged to a greater or less extent. In many instances these buildings were completely demolished. (Plate 109B.) Numerous wind-mills and tanks capsized, while at least 95 per cent of the brick chimneys thruout the town fell. Movable objects, such as pianos, were in most cases wheeled out into the room, but there did not appear to be any general direction in their displacement. Water and mud in many instances are reported as having spurted from the artesian wells, but in a few days they resumed their normal condition. The plate-glass windows on the south side of First Street were cracked much more than those on the north side. This phenomenon was not noticeable on the other streets.

Data were obtained of the directions in which the chimneys fell thruout the town. After the data were collected and tabulated as shown below, it became evident that chimneys usually fell with the slant of the roofs.

In order to group the directions in which chimneys fell, the circle was divided into 8 sectors, of 45 degrees each, starting from the bearing of First Street, namely N. 30° W. The general directions of these sectors are: N. 15° E.; S. 15° W.; S. 75° E.; N. 75° W.; N. 60° E.; N. 30° W.; S. 30° E.; and S. 60° W. Then the direction of the falling of a chimney was taken according to the sector toward which it fell. The streets in the main part of town run either parallel or at right angles to First Street. Since the bearing to First Street is N. 30° W., that of Santa Clara Street (at right angles to First) is N. 60° E. Generally the slant of the roofs of the houses that face these two streets will be N. 30° W., S. 30° E., N. 60° E., and S. 60° W., respectively. It was in these four general directions that the greatest number of chimneys were thrown over. The eight general directions are as shown on the following table :

*Directions of throw of chimneys.*

Directions.	On streets parallel or approximately parallel to Santa Clara Street, and percentages of total number down on these streets whose bearing is N. 60° E.		On streets parallel or approximately parallel to First Street, and whose bearings are N. 30° 39' 45" W.		Total number of chimneys counted in San Jose and their directions of falling.	
	Out of 710 chimneys.	Percentage.	Out of 2000 chimneys.	Percentage.	Out of 2710 chimneys.	Percentage.
N. 15° E. . . .	52	7.3	222	11.1	274	10.1
S. 15° W. . . .	43	6.1	184	9.2	227	8.4
S. 75° E. . . .	87	12.3	225	11.3	312	11.5
N. 75° W. . . .	69	9.7	248	12.4	317	11.7
N. (10° E. . . .	178	25.1	239	11.9	417	15.4
N. 30° W. . . .	58	8.2	362	18.1	420	15.5
S. 30° E. . . .	82	11.5	348	17.4	430	15.1
S. 60° W. . . .	141	19.8	172	8.6	313	11.5

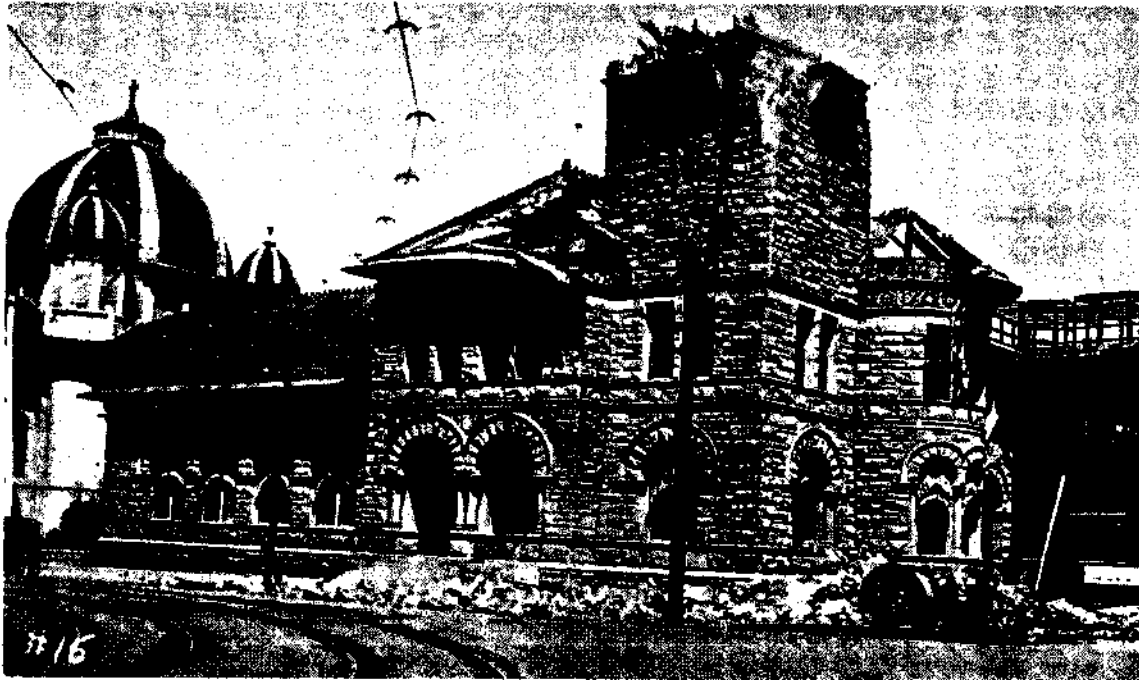

A. Post-office, San Jose!

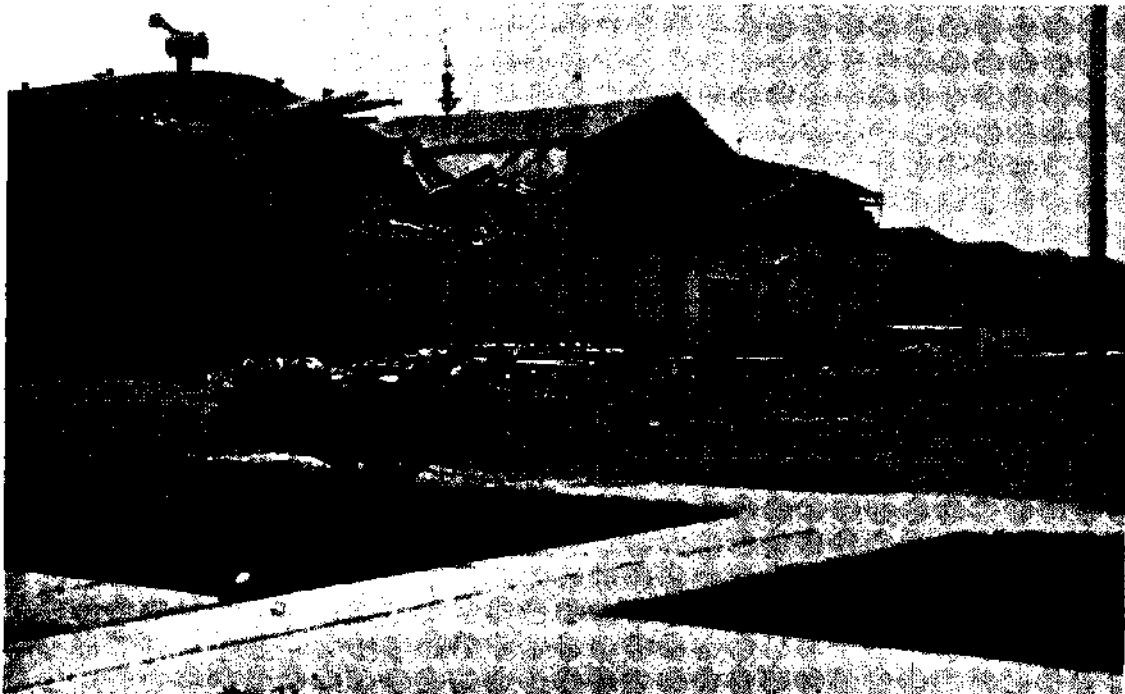

B. Box factory, corner Fifth and Julian Streets, San Jose. A. O. L.

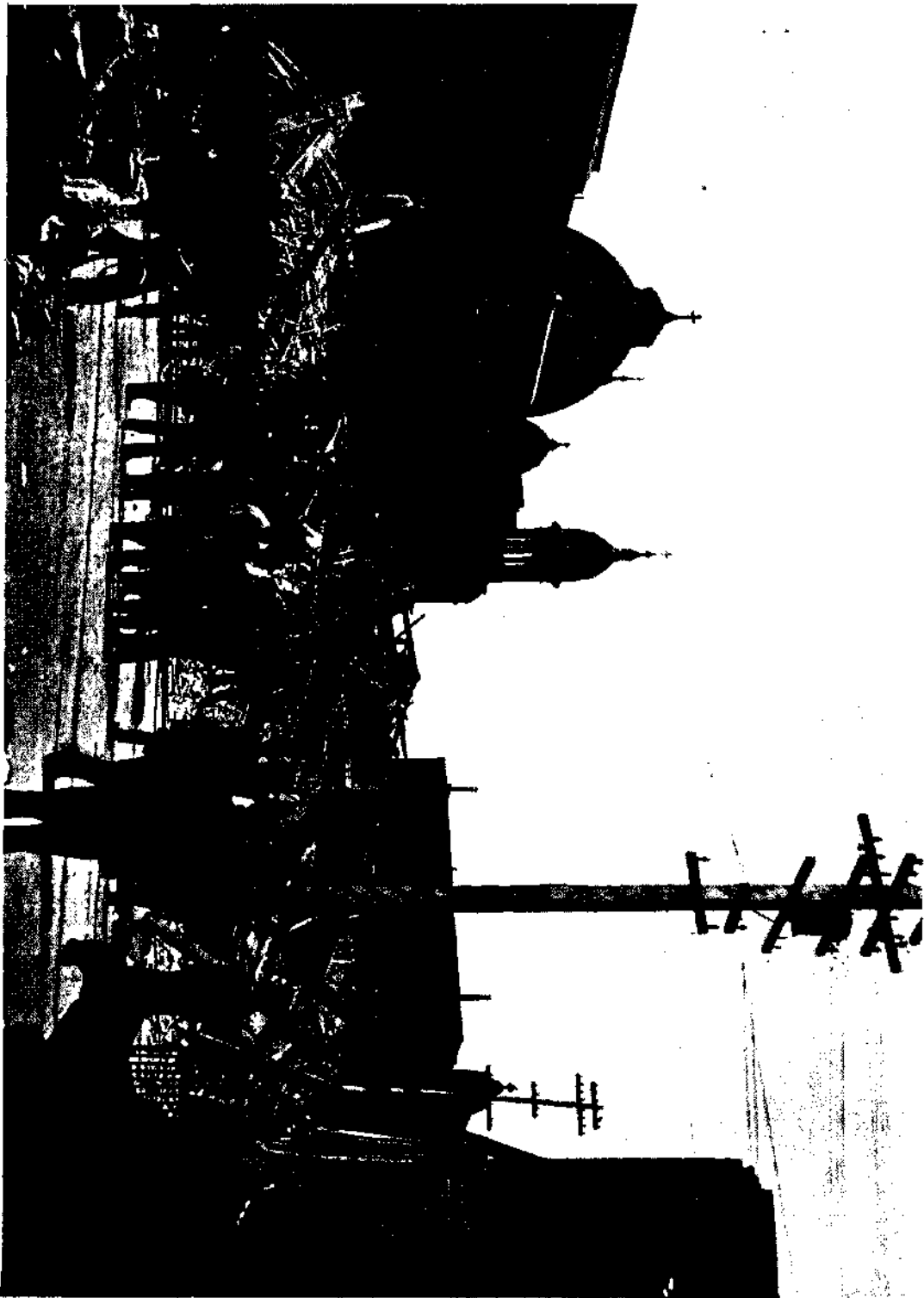

San Juan.

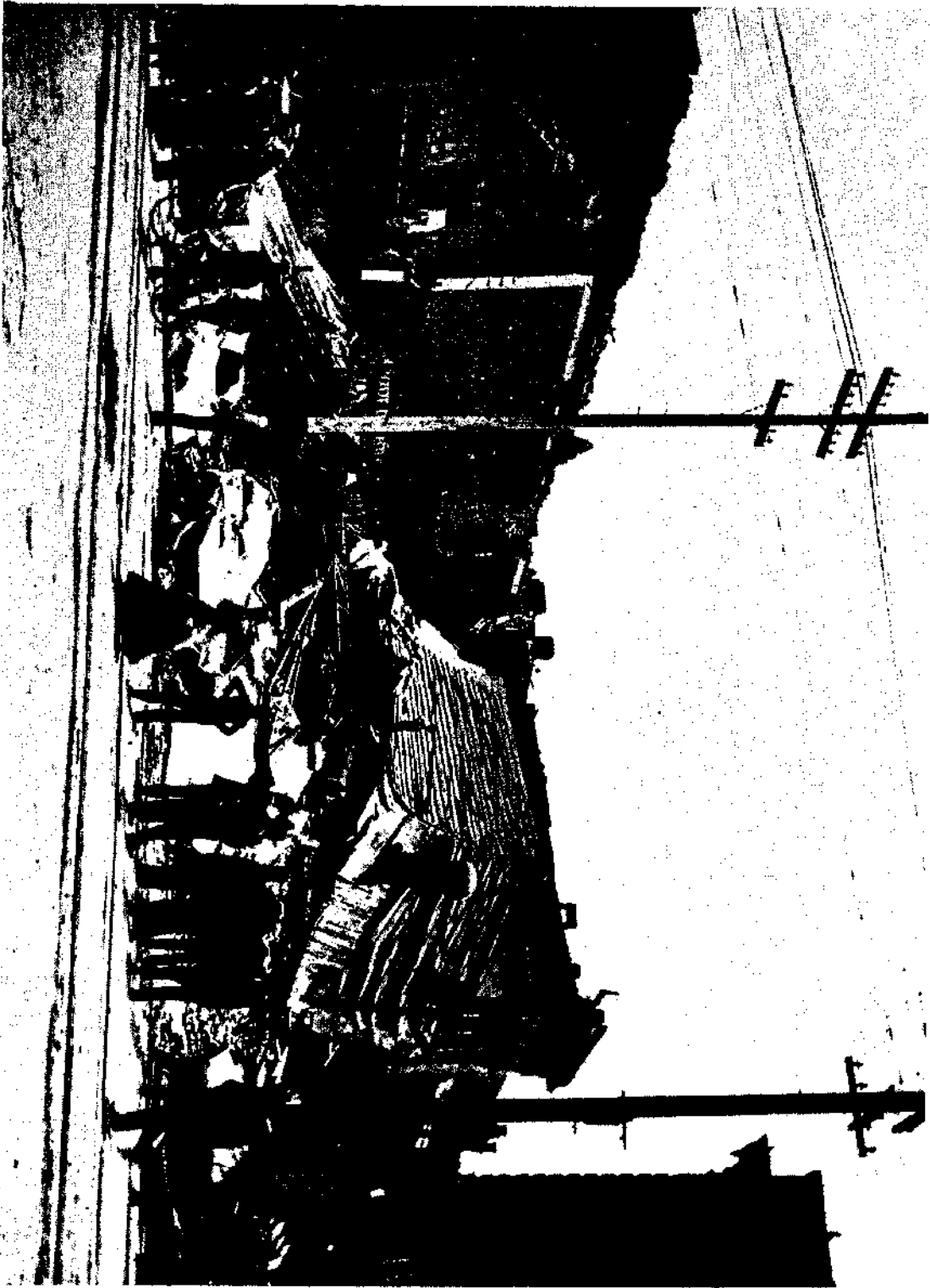

San Jose.





San Jose.

(E. C. Jones.)—There was only one broken gas main in San Jose, caused by the high wall of the building falling over; the bricks penetrated thru the soft earth to the main and broke it. At the gas station, the brick retort house was very badly damaged. The north and south gable ends fell out. The brick work at all 4 corners loosened for about 10 feet down to where the roof trusses are anchored in the walls. The superheater of one of the gas-making machines settled on the south side so that it was 2 inches out of plumb. The weight of this machine is about 78 tons. Some of the cast-iron connections in the building were broken.

The purifying house, also of brick, was totally destroyed; all the walls and the roof collapsed, carrying the machinery to the ground and destroying it. The relief gas-holder was full of gas at the time of the earthquake and was badly damaged. Two of the cast-iron columns were broken off in several places; portions of the railing fell thru the crown of the gas-holder, permitting the gas to escape. The distributing holder was three-fourths full of gas at the time of the earthquake. The movement threw about 12 inches of the water out of the holder tank. The carriages on the lower section were all broken, these being of cast-iron. The upper carriages, made of wrought iron, were strained but not broken. Considering the violence of the disturbance at this point, it is surprising that the mains did not suffer more than they did; but the breaking off of pipes in the buildings and the crushing of meters under falling houses necessitated shutting off the gas thruout the city for 24 hours.

(W. S. Prosser, C. E.)—Over the San Jose area, as a whole, the wreckage seems to have been thrown in all directions; but in certain places some slight system appears. It seems clear that no statement as to direction, amount, or even duration of motion applies to more than a limited area. The only clear cases of rotary motion seen by me were two cases near my home, 2 miles northwest of the center of town. One tank-house turned exactly halfway round, as well as upside down, and one chimney turned about 4 inches, both in the direction of the hands of a clock. Both rotary and vertical motions were felt by many, however. About 500 yards from me is a square brick fence-post 7 feet high, of which 2 feet moved about 3 inches to the southeast (S. 44° E.); or rather, the bottom moved the reverse way. On Stevens Creek road, leading southwest from San Jose, 5 or 6 water-tanks on the roadside fell. One of these seemed thrown to the northeast, but others were twisted and scattered as tho by a mixture of all motions. In some places most of the buildings, perhaps, fell to the north or northwest. In Chinatown (north of San Jose) it was the north and south brick walls that fell. In San Jose most of the clocks on east and west walls did not stop, but many of those on north and south walls did; showing an east and west motion. The brick 7-foot wall around the yard of Notre Dame School in San Jose, on the northwest side, fell; but that on the south did not, altho it was cracked. The streets in the central part of San Jose run N. 60° E.

The amount of motion differs greatly. In many cases brick work seems to show a sharp blow of 2 inches; sometimes more. The inside east and west wall of the City Hall has a crack of 4 inches. The front of La Mott House (east and west) moved in some places 2 inches, in others 4 inches. The master clock in the Western Union Office (on the ground floor of a large brick building, and on the east and west wall) did not stop, but the pendulum struck both sides of its case many times and with great violence, battering off the varnish. It is long (probably beats seconds) and had to move about 4 inches more than usual in order to strike the case.

About 5 miles south of San Jose there were said to be two tubs of water on the ground a few hundred yards apart. No. 1 had most of the water splasht out, but No. 2 apparently had lost none. No. 2 is nearer the hills, and bedrock is nearer the surface. The oil tank at the corner of Stockton and Polhemus Streets, 1 mile northwest of San Jose, splasht over. Many water-tanks did the same.

Several good observers out of doors are positive that the noise of the quake came from the southeast and died away toward San Francisco. In the afternoon of the 18th, my wife heard the noise of a shock and called out before we felt the shock itself. The noise seemed to come from the south or southeast.

Many persons saw waves in the ground. Sifting out exaggerations, these appeared to be rather more than a foot in height. The best observer estimated the distance from crest to crest at 60 feet, others at much less; but I think the waves must have been greater, for there is no evidence in long brick walls showing any such vertical cracks as would have been produced by short waves.

Six miles southwest from San Jose, a good observer described the waves as parallel with certain tree-rows which are northeast and southwest, and stated that the waves moved from him at right angles to the line and toward San Francisco. Six miles northwest from San Jose, a man looking south saw the waves (which he thinks were east and west) coming toward him, and hence toward San Francisco. About the middle of the quake these were met by other waves, and the whole surface resembled hillocks, or cross-seas, while the tree-tops waved wildly. To the man southwest of San Jose, however, the tops of the trees were almost still, while the trunks waved sinuously. Near me is a piece of ground 10 by 30 feet, raised about 7 inches; while about 150 feet southeast of this is an area about a yard square which dropt 6 inches. Possibly these represent the crest and trough of an earth-wave.

I estimate the duration, I think closely, at between 50 and 60 seconds.

The wells of the vicinity seem to show slightly increased flow. One 80 to 100 feet deep has been a little roily since the quake, and one near San Jose was reported as having increased the day before the quake.

(M. Connell.)—On the farm of Mr. Fox, 3 miles north of San Jose, the water pipe of an artesian well was broken off 60 feet below the surface and carried by the heave of the land in a northwesterly direction 4 feet from its original position.

*County road south of San Jose* (H. R. Johnson).—At Schutzen Park, 2 miles southeast of San Jose, the shock was felt quite severely. The road house was badly shaken, but very little glassware was broken in the bar-room. A 12,000-gallon water-tank was shifted slightly on its foundations. At this place the first part of the shock was thought to be quite light and the second part heavy; the general motion was said to be from east to west. At the 5-mile house, farther southeast on this same road, there was hardly any damage reported. Even plaster in houses did not fall. There was also little damage at the house 0.5 mile southeast of the 5-mile house. The chimney did not fall, but dishes and lamp-shades were broken. The movement was thought to be northwest-southeast in direction.

It was stated by Mr. Russel, of Edenvale, that the shock was lighter there than at San Jose. A well-constructed brick building, which was built 3 years ago, had the roof loosened and the end walls were cracked. About 3.5 miles southeast of the 5-mile house at the Van Every ranch, a chimney fell, plaster on the first floor was badly cracked, and furniture slid around upon the floor. Water was spilt from a tank and a water-trough.

Just northwest of the 12-mile house, where the county road crosses to the Fisher ranch, there were cracks from 2 to 6 inches wide in the coarse gravelly bottom of the Coyote River. There was evidence of water having been ejected from these cracks, as there were heaps of clean, fine material surrounding small orifices. It was said at the ranch-house that muddy water came out of these openings following the shock. Half a mile southeast of Fisher's, a water-tank was down.

Half a mile south of the 15-mile house, the Barnhart ranch-house, which was set upon wooden underpinning, was thrown from its foundation, so that it rested directly upon the

ground, 4 feet farther north than its proper place. An old barn and water-tank were uninjured at this same place.

A quarter of a mile south of the 15-mile house, on the county road, a water-tank was thrown down. Going 3 miles northeast from the 15-mile house, Webber's old ranch-house was visited. Here baled hay piled in a barn was shaken down and doors leaning against the house were thrown from their position. Water in both the creek (Coyote River) and a well was muddy after the shock.

(H. R. Johnson). — Going northeast thru San Felipe Valley to Smith Creek Hotel, hardly any evidence was seen of damage from the shock. At Smith Creek Hotel no china nor plaster was broken, but two chimneys were thrown down.

*Los Gatos to Gilroy* (G. A. Waring). — Near Meridian, 3 miles west of San Jose, several cottages were shifted from their foundations. All water-tanks on open frames fell, but those that were boarded in stood. The water became muddy in several wells. One lady reports seeing waves traveling southward along the driveway, and a man reports seeing a heavy wagon move 4 or 5 feet back and forth several times, along the driveway. The shock began violently and ended suddenly. The intensity diminished uniformly from Meridian toward Campbell. At Campbell, 68 per cent (51 out of 89) of the chimneys fell, but the plastering in the houses was not badly injured. From Campbell toward Los Gatos the intensity slightly increased. At Los Gatos 78 per cent (67 out of 86) of the chimneys fell. At the distillery 4 miles west of Los Gatos considerable damage was done. The second floor was moved about 18 inches toward the northeast, causing the wall to bow out on the northeast side. Many of the large vats holding 2,000 gallons were shaken off their supports and several were broken by the fall. The shock in Los Gatos, however, was not so sudden as to cause serious injury to brickwork or plastering. The business part of the town is built on 40 feet of gravel overlying shale. Only two stones in the Los Gatos Cemetery were shifted.

At Alma the shock was of about the same intensity as at Los Gatos. Milk in pans was nearly all thrown to the north and south. The Morrell house (see plate 107B), near Wright Station, is directly over the fault and suffered more than any other place in the vicinity of Wright Station, tho at least 5 other buildings between Patchin and Skyland were badly wrecked. Going from Los Gatos toward Edenvale, the shock was somewhat lighter than at Los Gatos, judging by the effect on chimneys, plastering, and movable objects; but at Edenvale it was a little stronger than at Los Gatos, as shown by the damage done to the large brick canning factory. All the walls were badly cracked and the tops of the walls fell. The top of the fire-wall above the roof was shaken down.

Continuing to the southwest thru Coyote, it was about the same as at Los Gatos, diminishing a little thru Madrone, Morgan Hill, and San Martin, where it had about the same intensity as at Los Gatos. Near Coyote a man reports having seen a northwest-southeast fence move in wave-like fashion, beginning at the southern end; and he heard a noise coming from the southeast and seeming to pass over him. Another man driving along the road near San Martin, heard a roar and his horse became frightened, before the shock came. Clouds of dust arose in the road and the creek near by was rendered muddy by the shock. At Morgan Hill about 64 per cent (18 out of 28) of the chimneys fell, and a 1-story concrete-block building was badly damaged, the whole front having fallen out. A 2-story reënforced concrete-block building was not damaged.

At Buckner, 3 miles north of Gilroy, the shock seems to have been about the same. The school building was badly damaged, and several windows were broken by the twisting of the frames. At Gilroy nearly every chimney fell, fire-walls of brick buildings were thrown down (plate 114A, B), and shelf goods were largely shaken down. In the Masons and Odd Fellows Cemetery, out of 120 stones over 3 feet tall, 31 fell. A cylindrical shaft fell north, and a square one fell south, but all the rest fell east or west, tho the tall slabs

necessarily fell east or west because they faced east. Two marble shafts about 8 feet high were broken off halfway up, the lower part and base being imshifted. In the Catholic Cemetery 10 stones out of 67 fell.

In the hills between Los Gatos and Gilroy the shock seems to have been somewhat less severe. At the New Almaden mines, the tops of 2 brick furnace chimneys, about 50 feet tall, were broken off; but the furnaces were unharmed and the underground workings unaffected. About 70 per cent (16 out of 23) of the chimneys in the settlement here (Hacienda) were broken off. A loud noise like thunder is reported to have traveled northward down the canyon, distinctly preceding the shock. This has often been heard since, seemingly underfoot, even when no shock has been felt.

Southward from New Almaden thru the hills the houses on alluvial land suffered noticeably more than those on more solid ground. From Uvas westward to the summit, the intensity rapidly rose as the fault was approached. Two miles west of Uvas P.O., and half a mile east of the summit, an east-and-west stone wall, built of loose boulders, was thrown mostly northward; water was thrown from troughs toward the north; and all streams were muddy for 2 days after the shock, while in wet places there was a noticeable settling of the ground.

Southward from New Almaden along the eastern side of the valley, the shock uniformly lessened in its intensity thru Old Gilroy and San Felipe to Hollister. At San Felipe a large stone cheese factory was not damaged, except for a few cracks. The lake 0.5 mile west of the village was considerably stirred up, and water from a full road tank was thrown 60 feet across the road. A considerable rumble was heard all thru this region; one person says it came from the southeast, traveling down the valley; another says it came from the southwest.

Along the railroad track from Gilroy to Sargent, nearing the fault, the intensity rose considerably, but the motion was a slow, swinging one. Water was all thrown from reservoirs, and trees swayed violently; but plastering and shelf goods suffered little. At Sargent all loose objects were thrown about, but no buildings were shifted.

(A. J. Champreux.)—About 90 per cent of the chimneys in Gilroy fell, the prevailing direction being east and west. No frame houses were thrown off their foundations. Brick walls were damaged at the top by the fall of 8 to 20 courses of brick. Most of the plastered houses suffered by the cracking of plaster. No cracks were found in roads or pavements. At the Cemetery, about 50 per cent of the monuments were overthrown. Of the fallen ones, 95 per cent were thrown in an east-west direction. All monuments overthrown had square bases.

#### HOLLISTER TO PRIEST VALLEY.

*Hollister* (G. A. Waring). — At Hollister (plate 114c, D) the chief damage was to the Grangers' Union, the Rochdale store, the Catholic school, and the fire-house. The two stores were poorly built, however, with large rooms unsupported by partitions or columns, while their shelves were heavily laden with goods. The school was on tall underpinning, very slightly braced, which allowed the building to lurch northward and settle to the ground. Unsupported parts of the fire-house walls (2 bricks thick) fell outward, but the portion braced by posts and tie-rods was unhurt. Sixty-five out of 123 chimneys fell, or 53 per cent. Several locked doors were thrown open, in one case the bolt being broken. One old settler remembers when the business part of Hollister was a slough. An artesian belt also passes thru the town, which may have affected the intensity along its path.

(A. J. Champreux.)—Practically all chimneys fell, the prevailing direction being east-west. One frame house, "School of the Sacred Heart," 2-story, was completely wrecked. The foundation gave way in the front part of the house, allowing the floor joists to drop.



A. Gilroy.

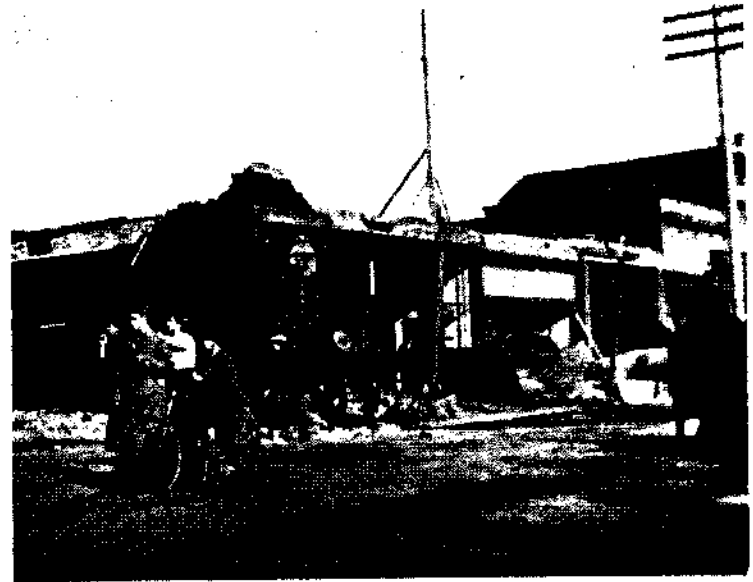

B. Gilroy.

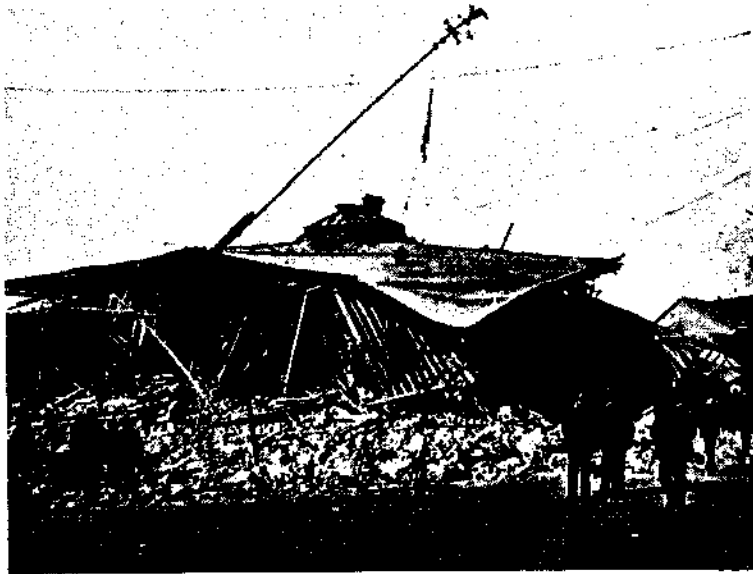

C. Hollister. Demolition of brick building shown in D. Blakesley Photo.

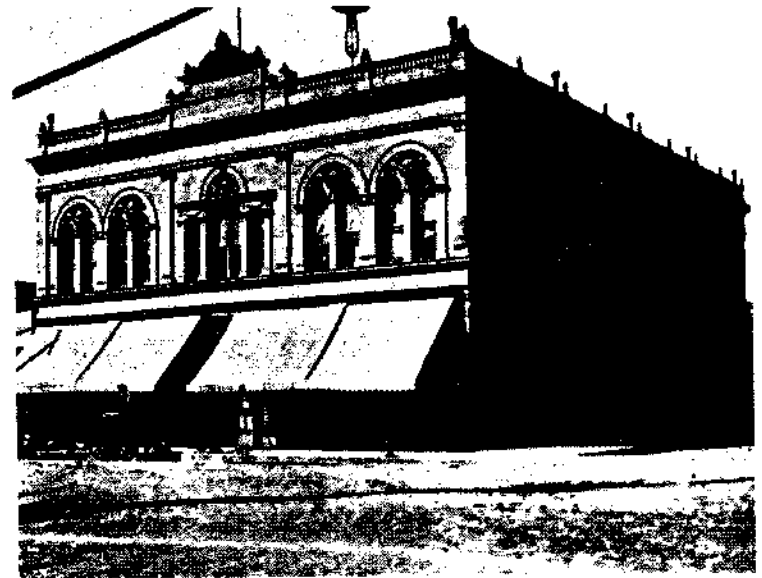

D. Hollister. Same building as shown in C, before earthquake. Blakesley, Photo.

This house was on the outskirts of town and on sandy soil. No other frame house was damaged. Two brick buildings, of poor construction, collapsed. The outer walls gave way, allowing the interior to drop.

(James Davis.)—Two shocks were felt, of which the second was the stronger. There was an interval of 3 or 4 seconds of less motion between these maxima. A rumble preceded the shock by a second or so. In my house a piano and other heavy objects were moved on a polished floor so that the north ends moved 2 or 3 feet out into the room farther than the south ends. I was standing at the time of the heaviest shock, and was thrown from side to side in a north and south direction. People here all agree as to the north and south direction of the movement. Most chimneys fell north, but some fell east and west. Pictures on east and west walls, hanging by single wires 4 to 6 feet long, swung from 3 to 8 feet along the walls, leaving distinct scratches. Pictures similarly hung on north and south walls simply pounded back and forth, leaving punctures in the plastering. Water-tanks seem to have fallen to the north always. Three brick buildings, each 2-story, 1 old and 2 new, went down flat, and 2 others were badly damaged. Wooden buildings in general were not damaged except thru the fall of chimneys. The Catholic convent, however, was injured.

There were no changes in the ground at Hollister save some slight cracks in the vicinity; but a small peak near Santa Ana showed a landslide down its steep face, plainly visible at a distance of 6 miles. A huge rock, rolling down a hill in Santa Ana Valley, crashed thru a house and killed a man.

(J. N. Thompson.)—All brick buildings were destroyed or badly damaged. There were 2 shocks, lasting in all about 50 seconds. The first appeared to be north and south, and the last part of the second shock appeared to be a twisting motion or a change to an east and west motion. My chimneys fell first, and nearly to the south; then at the last motion my wind-mill and tank fell to the west. The most damage was done at the close of the last vibration. A sideboard against a north wall was moved several inches to the south, and a clock on the same wall was thrown to the south. A bed against the west wall moved several inches to the east.

*From Hollister to San Benito* (G. A. Waring). — The effect of the shock upon alluvial soil is very noticeable. In the hills toward the Stayton Mines the shock was so feeble that it was not noticed by some people. Thru Brown's, Los Muretos, and Quien Sabe Valleys it was generally only sufficient to throw the cream from pans of milk. The often repeated story of the man who was killed in Quien Sabe Valley, by a rolling boulder crushing his house, is not to be accepted as a measure of the intensity. Several loose rocks were shaken down in the neighborhood of Santa Ana peak, and springs increased their flow; nevertheless the shock was very light.

At Palmtag's winery, in the hills southwest of Tres Pinos, the shock seems to have been more severe than elsewhere in the vicinity of that village. Furniture was moved, water was thrown from troughs, and an adobe building was badly cracked. One low brick winery was unharmed. A distinct rumble preceded the shock; 2 distinct periods were felt and the shock seemed very long. There is a small lake on the Palmtag place, and the ground seems rather marshy. Possibly this had some influence on the intensity, tho there is reason to believe that the projection of the fault passes thru the hills in the immediate vicinity.

At Tres Pinos, out of 18 chimneys only one fell and it was unstable. Shelf goods were almost unaffected. There is hard rock (sandstone or shale) in place, however, at a depth of 2 to 4 feet, at Tres Pinos.

Paicnes, tho south of Tres Pinos, was more violently shaken, for it stands on gravel. Milk and water were spilt somewhat, and a few tall bottles were thrown from the shelves. Water is said to have spouted up in the flat land along the river, 0.25 mile from the stream.

Toward the Cienaga lime-kilns the intensity lessened considerably. One man in the foot-hills 4 miles southwest of Paicenes, reports seeing a wave coming westward thru a grainfield, and some oaks waving considerably; but he did not hear nor feel any shock. Four miles southwest of Paicenes, a hanging lamp swung strongly east and west, and milk was spilt from the pans. At the kilns, in a granitic region, tho a distinct noise is said to have preceded the shake, only one slight shock was felt, and that was not sufficient to spill water from a full bucket standing on a table. Along the river between Paicenes and Mulberry, a distinct vertical motion is reported, causing weighted windows to be thrown up and down, and stove-lids to dance about. Liquids were strongly affected, as were trees and hanging lamps, and a few articles were thrown from shelves.

On the afternoon of June 13, a lady near Mulberry, 5 miles south of Paicenes, was talking over the telephone with a friend in Hollister. The latter suddenly gave a startled cry as a slight earthquake shock occurred. It was felt at Mulberry several seconds later. From Mulberry to San Benito the shock uniformly lessened until, at the latter place, altho distinctly felt, even liquids were not disturbed by it.

Thru Bear Valley the only noticeable effects of the shock were the swinging of lamps and the disturbance of water surfaces. Little or no sound was heard in Bear Valley, but several people noticed 3 distinct periods of vibration. It began easily, rapidly increased, and then, after a pause, there came a harder shake. At one house a lamp hanging by a chain 3 feet long is said to have swung north and south nearly to the ceiling. Articles on shelves were not moved, nor loose window lights shaken out. At the summit at the south end of Bear Valley, about a bucketful of water was thrown from a barrel only two-thirds full, and cream was thrown north and south from pans of milk. Here also the hanging lamp swung strongly north and south. A man outdoors became dizzy and nauseated, but did not at the time realize the cause.

Thru the south end of the valley, hanging lamps are said to have swung east and west, and water is said to have spilt mostly east and west. Several people became dizzy, but the motion seems to have been too slow to be distinctly appreciable.

At the Pinnacles no loose rocks were displaced, so the movement must have been slight.

Traveling southeastward from San Benito up the valley toward Hernandez, the motion consisted of longer, slower vibrations, and was of remarkably long duration. In general, the effect was only to set rocking-chairs in motion, cause doors to swing, and trees to sway. Just south of the divide between San Benito and Hernandez Valleys, the intensity rose noticeably, the shock throwing a lamp and clock from a shelf.

At Hernandez, pans of milk and troughs of water were almost emptied, and many minor shocks have been felt since. No noise was heard before the quake, but a report as of a blast immediately preceded the second (hardest) period of vibration. This is in an upland valley at 2,500 feet elevation, but the ground seems to be full of water.

In the mountainous serpentine area between Hernandez and New Idria, the shock was evidently slight, as nothing was noticed to have been disturbed at Smith's camp. At New Idria a few bottles and light articles were thrown from shelves, clocks were stopt, and a few bricks loosened from a building erected with mud mortar; but chimneys were not injured. One brick furnace was cracked, but it was not properly braced. Only 3 minor shocks have been noticed at New Idria. The intensity was about the same as at Hernandez.

In Vallecitos Valley, at an elevation of 2,000 feet, Tertiary rocks are overlain by 50 feet or more of alluvium. In this valley, pans of milk were slightly spilt, but nothing was thrown from shelves.

From San Benito southward thru the Bitterwater Valley, the intensity lessened, and only liquids were affected. The motion was too slight to be appreciable to some people.



*Priest Valley* (D. S. Jordan). — On May 18 I went to Priest Valley, in the southeast corner of Monterey County, 37 miles east of King City. I had heard that rumblings were frequently heard in the valley, and that people were moving out on account of them. There was little trace of the earthquake at King City. At Lonoak, 16 miles east, chimneys were thrown down and a mild earthquake was felt. At Priest Valley, which is near the line of the old fault and at the very foot of the main range of the Gabilan, the earthquake shock was very severe, apparently coming from the north. Chimneys were thrown down, dishes were broken, and the contents of the store thrown over the floor. Rumblings were alleged to have been heard by a man named George Brew. He had been hunting in the mountains, and said he had heard noises like cannonading in the ground at night. This was before the great shock.

There were slight landslides and cracks along the edge of the creek banks. There is, however, no trace of the great crack in the valley. No one had seen it cross the stage road; and the oil pipe line from Alcalde, in Fresno County, goes thru to the Salinas Valley without any break. The people said to be moving out of the valley were two frightened women up in a mountain gorge, whose husbands had gone to look after friends in San Jose. It is evident that the main crack did not reach as far as Priest Valley, and the shock at that point was not very different from that at San Jose, except that the blow was more direct, with less twisting motion.

#### MONTEREY BAY AND EASTWARD.

*Pacific Grove, Monterey, and Del Monte* (A. S. Eakle). — At Pacific Grove very slight damage resulted from the shock, altho according to residents the vibrations were very severe, in a northeast to southwest direction. Only one or two houses had chimneys cracked, tho there are several massive chimneys, some with heavy ornamental tops.

The town is situated on massive porphyritic granite, and the overlying soil is not deep. Its situation was evidently the reason for the slight damage done. The Pacific Grove light-house is situated about a mile southwest and this showed more severe effects. The lamp is enclosed in a ribbed metal frame which rests on a brick tower and dome. The vibration of the ribs caused them to strike the metal chimney in the center of the top and dent it on the easterly side. The motion of this upper portion caused the brick dome supporting it to crack immediately at the base of the curved dome. There was no displacement of bricks, the crack being a fine one, visible both within and without the tower, and completely encircling it. The light-house is built on a sand-dune and there is an estimated thickness of 80 feet of sand upon the underlying rocks. This sand foundation probably accounts for the apparently greater intensity of the shock here than in the town. Some of the objects in the rooms of the house were also slightly misplaced.

Judging the intensity of the earthquake by the damage it did in Pacific Grove, it would probably be classed as VI in the Rossi-Forel scale, as it was severe enough to awaken practically every one, tho no windows were broken, so far as could be ascertained.

Monterey experienced practically the same intensity. I could learn of no damage done to the houses, the only damage reported being of some glassware in a few stores. In some houses furniture was moved slightly, and top-heavy pieces were overturned. This town, like Pacific Grove, is on a good rock foundation; but in places the sand is deep-

Del Monte suffered the most, as practically every chimney of the hotel was cracked or thrown. There were over 50 chimneys in the hotel, and half of them were thrown down, one crashing thru the roof on the west side of the hotel and causing two fatalities. The chimneys were tall and top-heavy, having ornamental tops; and while the damage to the interior of the hotel was very slight, showing that the earthquake was not of a violent type, the vibrations were sufficient to throw these top-heavy chimneys. The hotel is on

alluvium, and the grounds surrounding it are in part "made" land. The grounds are surrounded by marshy land, ponds, and sand-dunes, and there is evidently a considerable depth of an incoherent, water-saturated formation supporting the hotel; this probably explains why Del Monte suffered so much more than Monterey. The houses adjoining the grounds were not damaged, with the exception of the school-house, which had its chimney cracked at the base.

On the road eastward to Salinas from Del Monte, no visible signs of the earthquake were encountered until the Salinas River was reached. The Salinas bridge was moved southerly several feet, according to report, and the framework was broken so as to render the bridge unsafe. The bridge farther down the stream, on a wagon road from Castroville railroad station to Monterey, was also damaged by the shock. This bridge crosses the river in a northeast to southwest direction, and is supported by four tiers of piles, boxed around with plank. The two end piers were not misplaced, but the two intermediate series were bent or broken at their bases and shoved over to the northeast, causing a sinking in the center of the bridge of about 2 feet. The damage to the bridge was due to the violence of the shock, and not to a sinking of the ground, as the amount of drop in the center was equivalent to the slanting position of the two intermediate supports.

*Castroville to Soquel* (G. A. Waring). — Castroville, being on solid ground, was not seriously affected. Three chimneys out of about 30 fell. Objects were thrown mostly westward. The quake was described as beginning like a subterranean blast. Two periods were not noticed; it was felt as one continual vibration, starting very gently.

The wharf at Moss Landing buckled up and partly collapsed, while the warehouses were wracked or fell westward. (Plate 116D.) At the hotel and stores on the mainland, brick chimneys fell, but plastering was not seriously cracked.

At Watsonville about 90 per cent of the chimneys were broken off at the roof-line, the greater portion being near to the river. Several were cracked and twisted but not thrown down. Parts of a few brick walls near the river fell, and considerable settling of the ground took place in Chinatown on the southern side of the river. (Plate 116A.)

On the higher ground between Watsonville and Aptos, the shock was little felt. There was no movement along Aptos Creek, both wagon and railway bridges being unaffected.

In one old house about half the plaster was thrown from every northern and southern wall on the first floor, but not from the others, nor from the upper rooms. A bureau was moved eastward 3 feet from the wall, but no other furniture was moved.

Nearly all the chimneys at Capitola fell, and considerable plaster was shaken from the north walls of the first floor of the hotel. The vibration is said to have been almost entirely east and west, as shown by the sash locks having been broken only upon the east and west windows. An iron safe free to move northward was unmoved, but the plaster on the opposite side of the wall back of it (west) was broken. A case of pigeon-holes resting on top of the safe slid to the east edge, when it could as easily have moved north. Much earth fell from bluffs near the town, but there was no appreciable effect on the surf. At the country bridge across Soquel Creek, the ground at the east abutment shoved inward, cracking the concrete and buckling a water-pipe.

In the low ground at Soquel, nearly all the chimneys fell, but most of those on high ground stood. Much plaster fell and goods were thrown from the shelves in the business section, which is close to the creek. The east abutment of the concrete wagon bridge over Soquel Creek cracked vertically, showing that the soil movement extended this far up the creek. Thru Delmar, Seabright, and Twin Lakes nearly all the chimneys were either down or twisted part way around and left standing, an unusual number being thus twisted. The shock is said to have come suddenly, diminished, and then, at a second jolt, chimneys fell. Trees moved sideways as well as swayed, and all animals were much frightened. One small stream has diminished in flow.

(D. Stirling.)—In the Pajaro Valley, on the McGowan ranch, at a bend of the river, an acre or more of orchard has sunk about 2 feet. At Moss Landing, where the river runs parallel with the shore line, the strip of land is seamed for miles. A crack, or rather a sink, about 20 feet wide and 4 or 5 feet deep ran under the buildings and rent them asunder. The office building between this crack and the river has been moved bodily—land and all—about 12 feet toward the river. Some of the cracks run into the ocean. At Neponset and Salinas the piling under the county bridges was moved in some of the bents at least 10 feet toward the river. A section man who stood in the midst of the cracks at the end of the Neponset bridge was drenched with spurting water.

#### SALINAS TO SAN LUIS OBISPO AND WESTWARD.

*Effect of the Shock on Alluvium* (G. A. Waring).—Altho the Salinas river bed sank nearly 6 feet at King City, and the wide sandy bottom at Three Mile Flat was much cracked, the southernmost extension of continuous cracks along the bank was found to be about 2.5 miles south of Gonzales bridge. From here to the mouth of the river the cracks are parallel with the river banks.

The movement at Gonzales bridge was mostly on the west bank of the stream. A wire fence trending north and south was torn 6 inches apart here, and wooden piles at the southwest end of the bridge, said to be driven down 75 feet, have been torn loose and moved from plumb, their original upright position. At the northeast end of the bridge the piles are undisturbed, but the surface soil and a wire fence have moved relatively 18 inches northward. (See fig. 59.)

North of Gonzales bridge the fissures are mostly on the west side of the stream channel, and reach a maximum width of 18 inches. No evidence of shearing could be found. In the creek bottoms west of Chualar, sand craterlets begin to appear and become numerous along the stream northward.

Near Agenda, in the lowlands, is a cracked area nearly a mile from the river, probably along an old water course; while sand craterlets are scattered thru the orchards. At Spreckels the movement caused much damage to flumes, sewers, and water-mains; and from here to Blanco the deep soil of the adjacent fields is much cracked and in places sunken and dotted with sand craterlets.

The county bridge south of Salinas was rendered unsafe by the movement of the piers at the southern end. (Plate 123A.) On the west bank near the bridge a series of peculiar cracks have torn up the road and adjacent field, along what is probably the path of an old water course. These are shown in plates 136, 137.

Between Blanco and Neponset the cracking and settling of the low land flooded the adjacent fields and gave rise to stories about the Salinas River having risen several feet. The "boiling up" of the water thru sand craterlets was also soon distorted into a story about the water of the Salinas River being boiling hot. Both the railway and county bridges at Neponset were moved, the northern concrete piers of the former 2 inches east and the central wooden pier of the latter apparently 4 feet south.

From Morocoho to Moss Landing fissures rarely show in marshy land, but the narrow-gage railway track has been shifted a few inches in several places. At Moss Landing many small cracks occur in the mud on the west side of the river, and the condition of the wharf indicates an eastward movement of the sand-spit. (See plates 134B, 135A, B.) It is reported that at places along the pier where the water was formerly 6 feet deep, it now has a depth of 18 or 20 feet. North of Moss Landing the ground settled nearly 2 feet in places, as shown by marks on railway piles at several slough crossings and by the sagging of the track below grade line in several other places. The stretch of narrow-gage track parallel to the coast has been disturbed for nearly its whole length; in some places it is wavy, in others the entire roadbed has shifted. At one point about 5 miles south of

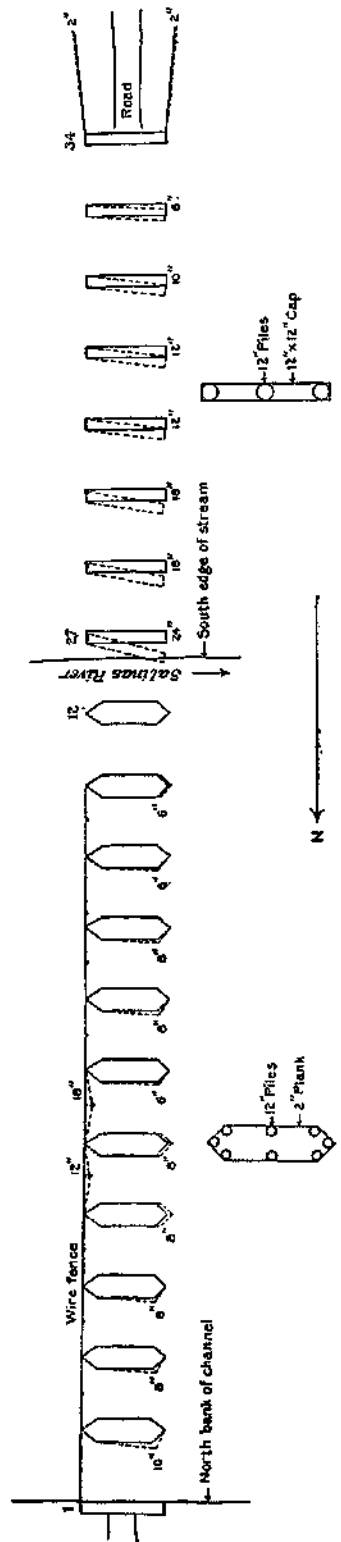

FIG. 83. — Displacement of piers of highway bridge across Salinas River, 3 miles west of Gonzales. The bridge is  $\frac{1}{2}$  mile long.

Watsonville, where the railroad track is only about 200 yards from the beach, a stretch 100 yards long running northwesterly had shifted a maximum of 12 feet to the northeast. Fences, telephone poles, and track all moved together. The sand-dunes facing the beach directly opposite the place where this movement occurred look as if they had been struck by a single large wave.

Cracks appear again along the Pajaro River and the railway track has sunk in several places. The side rods of the narrow-gage bridge 1 mile south of Watsonville are buckled as by a compressive force, and the roadbed at both approaches has settled at least 2 inches.

Continuing up the Pajaro River, evidence of settling is found at the broad-gage railway bridge at Watsonville, the southeast end of which sank more than a foot. The track was also twisted into an S-shape. The concrete foundation under the engine and stack at the power-house at the northwest end of the bridge settled, but the concrete work was little hurt. In Chinatown, on the south side of the river, the settling of the ground was marked.

Between Pajaro and Vega the ground cracked along the 2 to 6 foot bluff, marking the old river bank on the south side of the present channel, and the side toward the river has settled several feet. This is well shown in plate 141B. This displacement has caused numerous sand craterlets and pits (plate 143B); the largest pit noted being oval in shape, 6 by 20 feet in diameter, and 4 feet deep. Northeast of Vega the movement seems to have died out, the last evidence found being mud caps on some old piles in the channel of the stream, showing a settlement of the ground amounting to 8 inches. Between Vega and Chittenden no evidence of movement of the river-bed could be found. Near Chittenden the banks are caved in. Along the San Lorenzo River, at Santa Cruz, this settling action also took place for a mile or more upstream from its mouth.

It may be said, regarding the soil movement along these streams, that along the Salinas River from Gonzales to near Blanco, everything shows a movement down the river. From Blanco to Neponset the movement seems to have been a settling of the alluvial materials, while from Neponset to the mouth of the Pajaro River the ground (in several places, at least) moved eastward or inland. Accepting as correct the reported lengths of piling at bridges, and depths at

which the sand thrown up is said to have been found, the plane of movement must have been about 90 feet below the surface at Neponset, diminishing to possibly 8 or

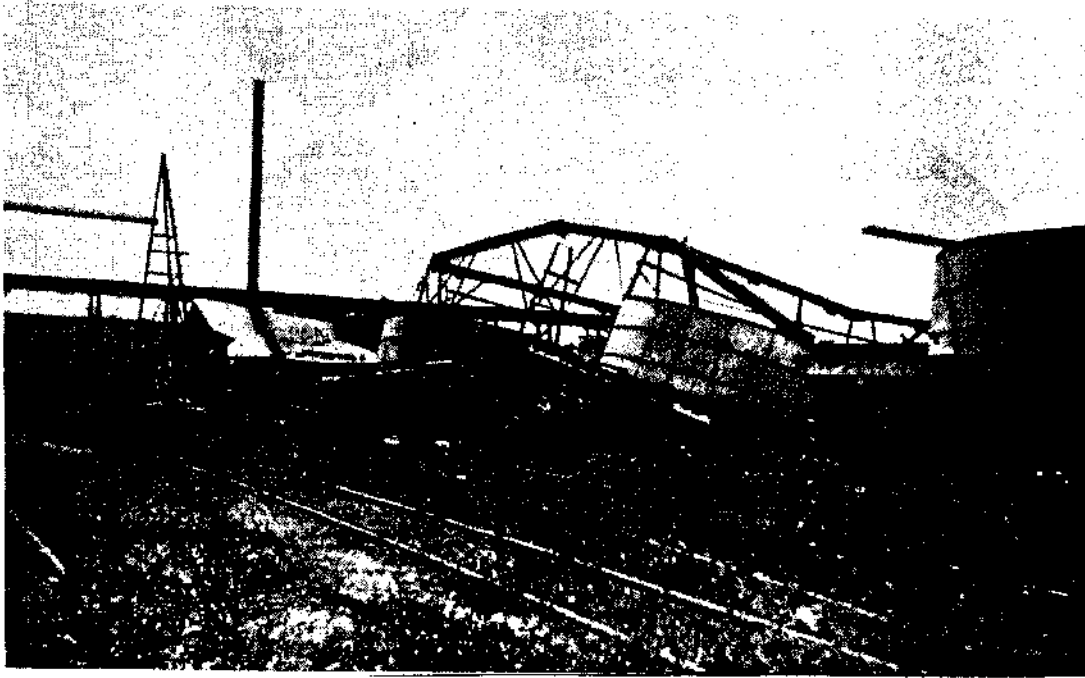

A. Alvatadoi Wreok of molasses tankB, Alameda Sugar Company, E. W. B.

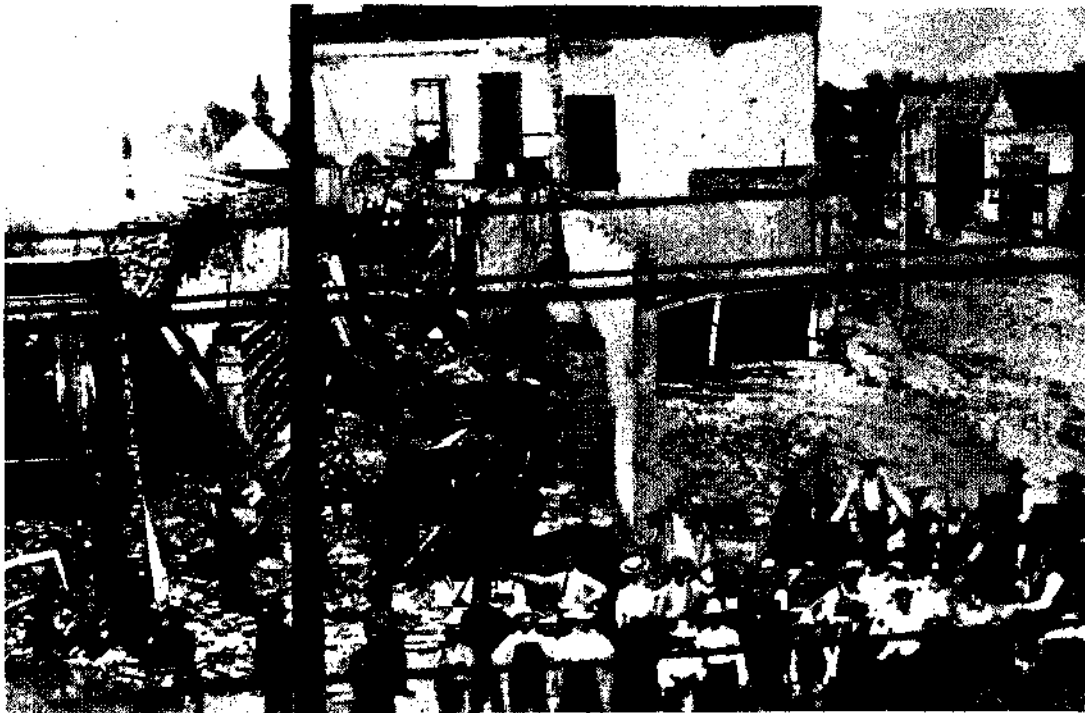

B. Salinai. Wreck of corner ttor\*. & B. B.

10 feet at Gonzales bridge and ending about 2.5 miles south of it. Along the Pajaro and San Lorenzo Rivers the movement was a settling of the alluvial bottom-lands.

(A. S. Eakle.) — The effect of the earthquake upon the alluvium was well shown along the banks of the stream from the Salinas to the Gonzales bridges. Along the east side of the river for a short distance south of the Salinas bridge, 4 miles south of the town, the land is cracked at the edge of the bank, the cracks paralleling the course of the river; but comparatively little cracking was observed on this side of the river. Along the bank and down in the river-bottom itself, on the western side of the stream, fissures were very prominent. The county road southward from the Salinas bridge runs along the embankment about 10 to 20 feet above the stream bed. The road is an oiled one, and the oil had formed a hardpan upon the underlying sand. In the vicinity of the bridge the road has been shattered by the quake for a distance of 200 yards. The breaks are in the nature of a caving in of the road on the north side of the crack, as if hollow spaces existed beneath, leaving a vertical escarpment on the south side. The main sinking is at the most southerly fissure. Here the road has sunk bodily to a depth of 10 feet, leaving a high vertical bank diagonally across the road, and this sunken area extends for some distance into the adjoining field on the west. There is no upheaval of the road in any place to compensate for the sinking.

South of the Spreckels factory, the low bottom-land between the banks of the river is considerably cracked, although there is no prominent vertical dropping of the land along the cracks. This low land lies west of the present course of the stream, and is intersected by sloughs and former water courses. All of the ground is of a deep sandy nature, consequently it was much disturbed and fissured by the quake, and the fissures became filled with water and sand, forming a quicksand, this wet sand frequently being spouted into the air. No one noticed gases coming up. The position of the cracks is now marked by patches of light, bluish-gray sand in the field, from the drying out of the quicksands. Houses on this low land were thrown out of plumb, and chimneys were destroyed. The cracks diminish in number as one goes southward, and practically end in the vicinity of the Gonzales bridge. The quake at Gonzales can hardly be placed at more than VII in the scale, as comparatively little damage was done to the town.

*Effect upon structures, objects, etc.* (G. A. Waring). — It is remarkable how closely the disturbance followed the river channel throughout the Salinas Valley; 2 or 3 miles away from the stream on both sides the intensity was very slight. Southward up the valley the shock gradually lessened, and rapidly died out in the foot-hills on either side.

In the hills between San Juan and Natividad the ground is not cracked, except for a few places on hillsides where there was some sloughing off. The shock was sufficient to throw nearly all the milk from the pans, but not strong enough to move furniture or shelf goods. At Natividad, in the foot-hills, the shock was of about the same intensity. At Santa Rita the shock was light; a little milk was spilt from pans, but several tall slender chimneys were unhurt.

*Prunedale* (H. H. McIntyre). — Nearly every chimney was thrown down. All the goods in the store were thrown to the floor. The house was badly wrecked. Water started flowing in many places where there had been none, or but little, before. There were 2 small landslides from springy places, the direction of the slip being from north to south.

*Salinas* (G. A. Waring). — At Salinas 42 per cent (278 out of 655) of the chimneys fell. A brick store was demolished by the collapse of the roof (plates 115B, 116B), and parts of a dozen or more brick walls fell. (Plate 116c.) Shelf goods were shaken down, and a few heavy articles, such as slot machines, were overturned. Heavy furniture, such as pianos and billiard tables, was not moved. But little plate glass was broken. In

some buildings plastering was badly cracked and shaken down, but in solid, well-built residences it was little hurt. The court-house and high-school buildings, within a block of each other, furnish striking examples of the need of considering construction when trying to gage the intensity of the shock by its effect on buildings. In the former building the principal damage consists of a few cracks in the plastering and foundations, while in the high-school building a part of the front wall fell out and the roof spread badly, cracking the corners of the house.

(A. S. Eakle.)—The town of Salinas suffered greater destruction than any other place in the county. Nearly every house and building were damaged to some extent. Plaster fell, windows broke, chimneys fell or were cracked, and brick buildings had their upper portions thrown off and, in some cases, almost completely demolished. The town is on the flat valley land, about 3 miles east of the river, and came within range of the more violent vibrations, in addition to being on alluvium.

*Spreckels and vicinity* (G. A. Waring).—The village of Spreckels, on the river-bottom, was badly shaken. Nearly every one of the approximately 50 chimneys in the settlement fell, as did also a large part of the plaster in the 3-story hotel. On the first floor of the hotel building nearly all the walls were stript, but the plaster fell mostly from the south wall. On the second floor the walls of the north end and west side suffered most, while on the third floor the north end (walls and ceiling) was shaken the hardest. In the 6-story, steel frame, brick sugar mill (plate 117A, B) the bricks along the I-beams of the north end were thrown out, as were also those of the upper central part of the west wall, and part of the top cornices of the north and south ends. Oil in a large tank was thrown toward the southeast. The front (north end) of the 2-story brick office building exhibits a remarkably symmetrical set of cracks.

(A. C. Lawson.)—The flood plain of the Salinas River was caused to lurch toward the stream from both sides, but the effects are most marked on the south side. The result in most places has been the breaking up of the alluvium into monoclinical strips with a vertical scarp on one side, facing the river, and a gentle slope on the other. These have the effect of landslide scarps and terraces, but occur on flat land. In some instances it would appear that the ground had collapsed into the cavity formed by the lurching. There are minor cracks and buckles in the sand and mud flats of the river-bottom. Here numerous craterlets were formed by the sudden ejection of water from the underlying sands, due to the compressive action of the shock. This acute deformation of the ground accentuated the destructive tendency due to the earthquake shock.

At the bridge, a large trussed structure in 2 spans having a bearing of N. 27° E., the south pier, consisting of 26 piles incased in planking, was thrust to the south between 6 and 7 feet, so that the entire pier was inclined as shown in plate 123A. The piles were not broken at the ground level. The north and middle piers were apparently not affected. An oil pipe which crost the bridge was buckled and twisted at the south end of the bridge, and when this was repaired the pipe was found to have been shortened 7 feet. The pipe line extends from the San Joaquin Valley to the Bay of Monterey. A few hundred yards to the south of the bridge is a pumping station, and at this point some of the connections of the pipes were broken and displaced. The direction of the shortening of the bridge span and the pipe is roughly normal to the direction of the San Andreas Rift, on the other side of the Gavilan Range. Mr. S. A. Guiberson, superintendent of the line, reports that the pipe was broken in about twenty places in the vicinity of the river, and that at some of these breaks the pipe was pulled apart.

A few hundred yards east of the bridge, on the south side of the Salinas River, is the Spreckels sugar-mill, a steel structure incased in brick, about 500 feet long and about 150 feet wide, having a northeasterly and southwesterly orientation. This building is five stories high, but the five stories occur only at the two ends of the building. In

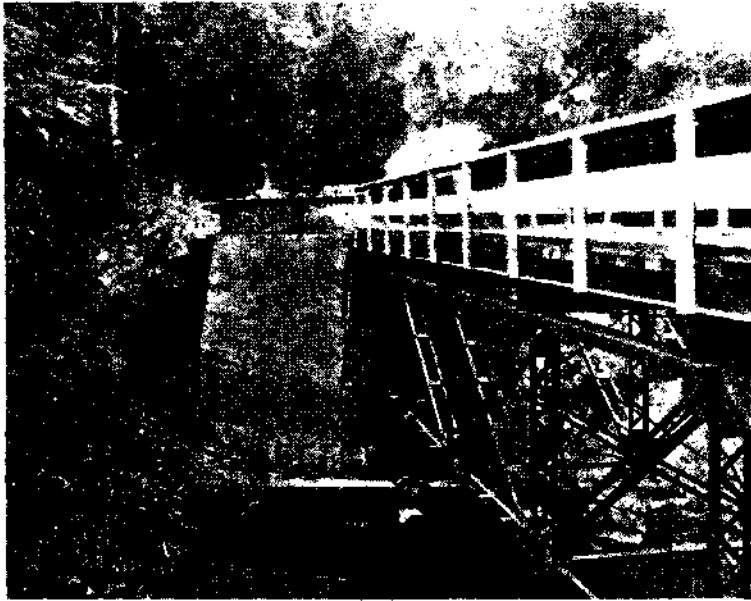

A. Near Watson-rille. Concrete pier of bridge shattered! Per J. O. B.



B. Bflnas. Wreck of store. & B.B.

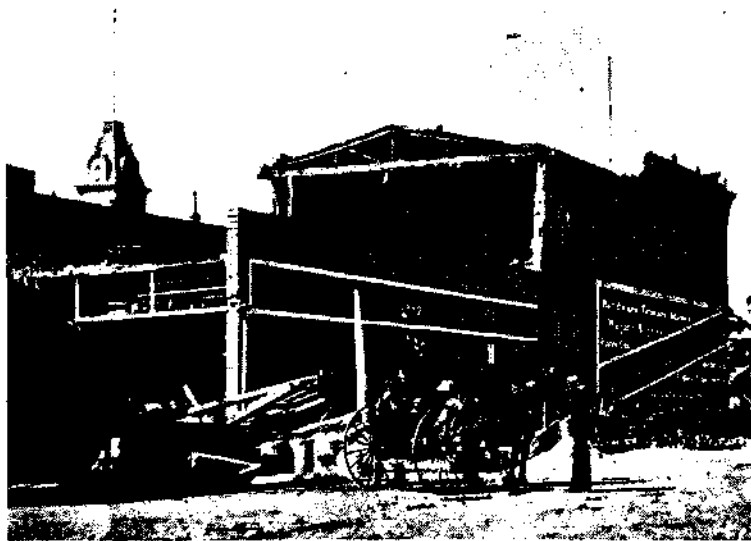

C. Salinas. Walls of building thrown out. G. E. B.



D. Hoss Landing. Wreck of wooden warehouse. G. B. B.



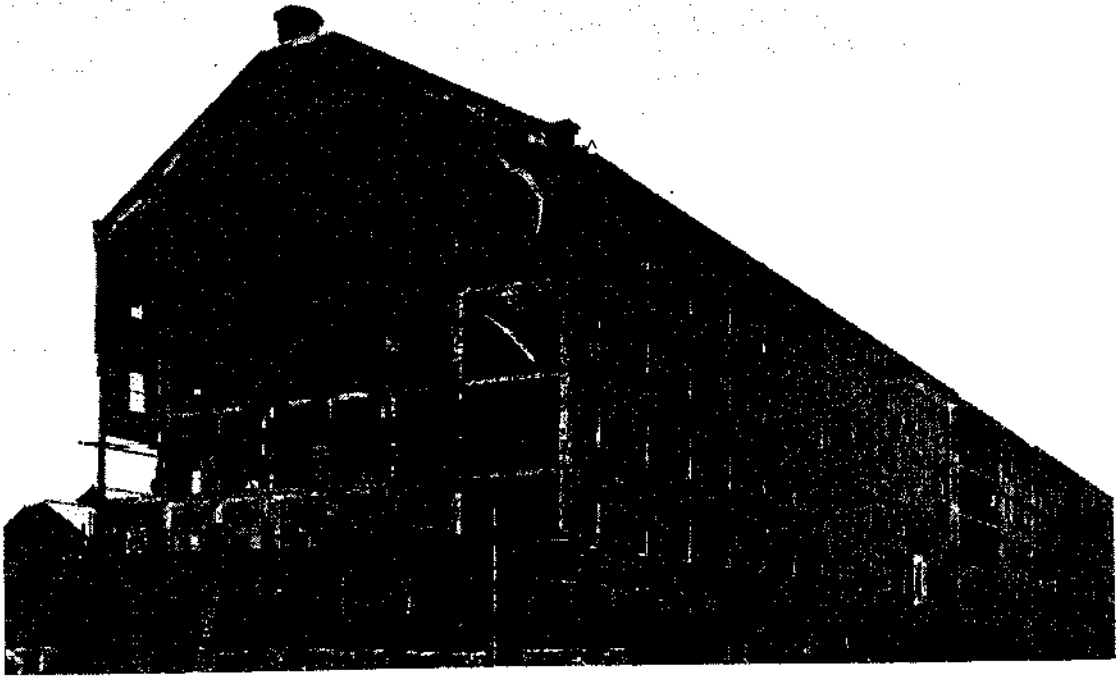

A. Spreckela sugar mill, near Salinas. Entire building buckled. Looking southeast. R. L. H.

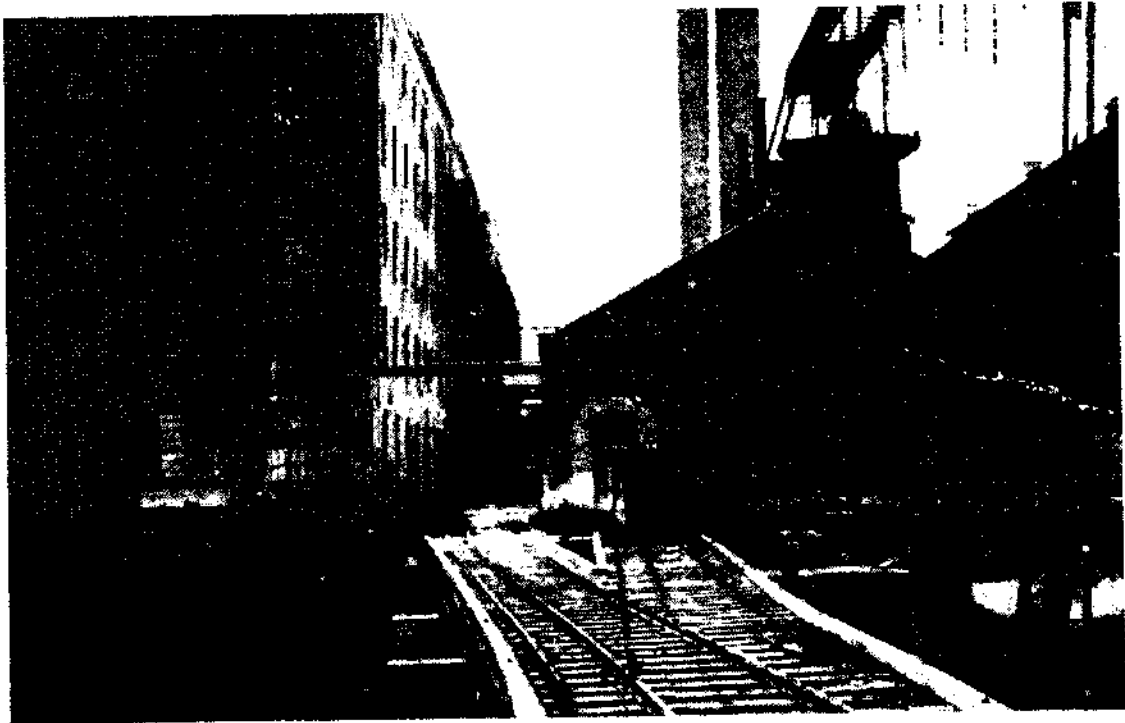

B. Spreckeli sugar mill, LooHsg northweit. A. O. L.

the middle 100 feet of its length there is only one floor above the ground-level, and above this the structure is open to the roof, without cross-ties or floor-beams. This building yielded to the shock in a most remarkable and instructive manner. The whole structure was shortened along the line of its longer axis, this shortening being effected by the buckling of the walls at the middle or weak portion of the building. Both walls bulged toward the west, the east wall in and the west wall out, as shown in plate 117A, B. Within the building considerable damage was done to the heavy machinery, tanks, etc. The ground to the south had been much heaved and otherwise deformed, causing the wrecking of trestles, pumping-house, and other structures. The rails of a track at the rear of the building were pulled apart, due probably to the slumping of the ground toward an old slough of the river.

In the bottom of this slough water gushed forth at numerous places at the time of the earthquake. It is said by those who witnessed the phenomenon that the water spurted repeatedly as high as 20 feet, and that the outflow of water lasted for 10 minutes after the shock. The places where the water spurted forth are marked by areas of fine, light, bluish-gray sand, which is said to be known only at a depth of 80 feet in the various well borings of the vicinity. In these areas of fine bluish sand are often funnel-shaped depressions or craterlets from which the water issued.

(S. A. Guiberson, Jr.)—As superintendent of the pipe line, I am in a position to say that we have no breaks whatever in any place between Coalinga and the Salinas River, and there were no fissures of any kind along the line between these points. This I know positively, as I have line riders who were instructed to look closely for any disturbance of this nature. The line of fissures seems to have ended north of Priest Valley. The conditions prevailing along the Salinas River, and some of the peculiar circumstances attending the breaking of our line in\* about twenty places, are of interest. I was on the ground the following day, and only regret that I did not have time to have some of the peculiar features photographed. In places our line had been broken and the ends were 3 feet apart; at the same time the ends of the pipe would be hammered up, showing that there had been an opening and closing movement at that point, while at other points the line would overlap as much as 4 feet. One of our stations is in this zone of disturbance, and the engineers, being on duty, had an excellent opportunity to see what most of us who were in bed merely felt. They state that these fissures were opening and closing, and that the water and sand would go 20 feet in the air as they closed.

*Southward from Salinas* (G. A. Waring).—At points along the railroad liquids were generally spilt, furniture was moved, and chimneys cracked. At Chualar, 3 out of 29 chimneys fell, but 2 were on an old house and were probably weak. At Gonzales the intensity seems to have been about the same as at Chualar. Out of 150 chimneys 11 fell, while many were cracked. East of Gonzales, near the foot-hills, houses were barely shaken; while to the west, near the river, water-tanks were thrown down. At Soledad 3 out of 8 chimneys fell, but the number is probably too small to be taken as a criterion of intensity. Some plastering on the first floor of the hotel was slightly cracked, a few glasses were thrown from the bar, and some of the bottles were turned around. The frame of the railroad tank was so badly twisted that it had to be taken down. A chandelier swung northeast-southwest with a double amplitude of 18 inches.

At King City, close to the river and on low ground, the intensity was considerably higher than at Soledad. Heavy objects, such as a printing-press, slot machines, and ice-chests, were shifted a little, and a few things were thrown from the shelves. One low chimney on a low fire-wall fell, but the wall was without a crack. No other chimneys were injured. The river-bed sank nearly 6 feet in the vicinity of King City. At San Lucas the intensity was considerably lower; milk and water were spilt and shelf goods disturbed, but no chimneys fell.

On the western side of the valley from Salinas to San Lucas the same kind of evidence was found as at corresponding points on the eastern side. At Fort Romie most of the clocks stopt, a few articles were thrown from the store shelves, and water in a north and south canal was thrown over the sides. No sound was heard during the shake, but it is reported to have come afterward.

About 4 miles south of Fort Romie, water was thrown 30 feet northward from a full tank, the top of which is 14 feet above the ground, and half the milk was thrown from half-filled pans. West of San Lucas, waves were reported to have been seen moving southward over the hills and a sound to have been heard. The shock began gently, was followed by a harder shake, and died away slowly. Thru San Ardo, Bradley, and San Miguel, the shock lessened uniformly. At San Ardo a water-tank frame was somewhat wrenched, and the river-bed is thought to have sunk about 2.5 feet, the evidence of this was not obtained. Oil was spilt from a large tank, and quicksand was thrown up in a well, which seemed to lessen the flow considerably. The railway station at Bradley, standing on made ground, settled 2 inches at one end.

At Paso Robles a number of clocks were stopt, most of which were facing east or west. Window weights rattled and lamps swung about, but plastering and shelf goods were not affected. The duration of the shock was estimated at 40 seconds, but was very-gentle.

In the southeastern end of the Salinas River drainage area, at Shandon, Cholame, and Parkfield, the shock was notable as being "the longest, easiest one felt in many years"; liquid surfaces were somewhat disturbed, a few clocks were stopt, and hanging objects were set in motion. In the hills 2 miles northwest of Shandon the intensity was somewhat greater, as it was also to the southeast in the Red Hills. At Shandon, a saddle hanging by a wire from the rafters swung north and south, and water was thrown from a full horse-trough. The shock was also reported at Estrella and Linne.

*South and West of Salinas Valley* (G. A. Waring). — Following southward over the divide thru Templeton, Santa Margarita, Dove, and Guesta the shock lessened until it was hardly more than distinctly felt. At Templeton skimmed milk was spilt at one place, but unskimmed milk was not. At Dove the swaying of the telegraph wires was about the only evidence noticed. At one place a mile east of San Luis Obispo a great roar is reported to have been heard.

In the coastal range of hills thru Carmel P.O., Jamesburgh, and Jolon, only milk and water were disturbed, but from the latter place to Los Osos Valley, west of San Luis Obispo, the shock varied considerably. At Lockwood the shock was a little stronger than at Jolon, clocks being stopt generally and milk and water spilt, but no shelf goods were moved. Thru Hames and Pleyto it hardly more than wakened sleepers, and people moving around did not feel it; while at Adelaide clocks were stopt, shelf goods moved, and liquids spilt. Several minor shocks have also been felt at Adelaide. In Los Osos Valley, however, the shock was barely felt; sound sleepers were not awakened. A few light things, such as table covers, swayed slightly, but no sound was heard, and pans of milk were undisturbed.

At San Luis Obispo the shock was hard enough to waken all ordinary sleepers. Some people thought it a wind-storm. The vibration is estimated by some to have lasted 20 seconds. Mr. John R. Williams states that the shock made doors and windows rattle, moved his bed, and stopt some clocks. There was but one principal disturbance, which gradually increased in intensity and then died away, lasting about 50 seconds. The apparent direction of movement was northeast and southwest. The night operator at the telephone office was talking with Salinas at the time the shock occurred. She heard a scream at the Salinas end, followed by a roaring sound. Fully half a minute later the shock was felt by her at San Luis Obispo.

Along the coast northward from Port Harford thru Morro, Cayucas, and Cambria, to San Simeon, the intensity gradually rose. At Morro some people in bed and awake felt it; many others did not; while at San Simeon liquids were somewhat disturbed and the shock of the afternoon (of April 18) was also noticed, which was not the case farther south. At Piedras Blancas Light-house a clock stopt and the shock was distinctly felt.

Between San Simeon and Posts the country is almost uninhabited, and not easily accessible, so it was not visited. At Posts a clock was stopt. The shock was very appreciable, and several minor ones have been felt since. At Idlewild several articles were thrown from shelves, windows rattled, and the redwoods swayed considerably. At Sur a clock was stopt and the shock was apparently a little stronger. At Carmel-by-the-Sea, on deep, sandy soil, several people ran out of doors, a cobble-stone chimney fell, and a few tall articles were tipped from shelves.

#### SAN LUIS OBISPO TO SAN BERNARDINO.

This portion of the state is on the southern fringe of the region within which the shock appealed to the senses. The shock was not exceptional in intensity and the people paid little attention to it; therefore records of observations as to the effects produced are few. Such reports as have come in, however, indicate that the shock was more or less distinctly felt thruout the country north of the Santa Barbara Channel and the Valley of Southern California, as far east as San Bernardino.

*Arroyo Grande, San Luis Obispo County* (G. P. Ide).—Pendulum clocks facing north and south were stopt, while those facing east and west were not. Very few objects were overthrown. A hanging object swung east and west in an elliptical orbit.

Other points south of the town of San Luis Obispo at which the shock was reported are:

*Pismo*: Hanging objects swung from east to west, and some clocks stopt.

*Edna and Oceano*: Clock stopt.

*Port Harford*: Slight shock.

*Santa Maria, Santa Barbara County* (F. R. Schank).—I was asleep in the second story of a brick building and was awakened by the first of 3 shocks. The shock awoke people generally and was observed by persons moving about, but did no damage. The motion was a slow, easy one. Wooden inside shutters at my windows swung thru a considerable arc, and an incandescent lamp suspended by about 5 feet of cord vibrated with an amplitude of about 6 or 7 inches in a plane approximately east-northeast. The length of the first and second shocks was 1 or 2 seconds, but the third shock lasted between 12 and 15 seconds.

*Casmalia, Santa Barbara County* (C. H. Stephens).—I was awakened by the jar, and the rocking was continued for about a minute, when all became quiet. It then started again lightly, getting stronger as it proceeded and gradually dying away in about 45 seconds. The third shock came quite strong, and 6 waves followed close on each other, each stronger than the preceding one. The clock was stopt, and some articles of furniture were overturned.

*Surf*.—A clock was stopt.

*Lompoc, Santa Barbara County* (O. K. Studley).—I was in bed, awakened by the first slight trembling. My bed stands east and west, with the head to the west. The first shock moved me up and down from head to foot. The second shock rolled me from side to side. The first shock gradually increased to a maximum, and then died out; the second seemed to be about the same intensity thruout, and stopt suddenly. The latter set the window weights on the south side of the house rattling quite rapidly. The hanging lamp suspended from the ceiling of the lower story by a chain, which would make it about equal to a pendulum that beats seconds, swung in an elliptical orbit, the longer

diameter being 10 inches in a west-northwest direction and the shorter diameter 4 inches in a north-northeast direction. The motion in the ellipse was clockwise. The clock stopt.

*Point Conception Light-house Station* (Mr. Austin). — While cleaning up in the tower at 5<sup>h</sup> 20<sup>ra</sup> A.M., the keeper felt the lens shake. No one else at the station felt the shock.

*Santa Barbara* (J. A. Dodge). — I was aroused from a half-sleeping condition by a singular rustling noise in the house. None of us recognized it as an earthquake at the time. My bed was not perceptibly shaken. Nothing was shaken out of place, no plastering was cracked, and no clocks were affected. The sound referred to was produced by something in the structure of the house creaking or vibrating. Other reports state that some hanging objects were caused to swing, and that one woman was made dizzy.

*Carpenteria, Santa Barbara County*. — The shock was sufficient to rattle dishes and slightly move beds, but few people were awakened by it.

*Saticoy, Ventura County* (E. O. Tucker). — Water in a trough which was 6 inches from being full, slopt over nearly a pailful at a time from the ends. The trough lies from north-east to southwest. A rattling noise was heard in the house, but no motion was felt.

*Hueneme Light-house Station, Ventura County* (C. F. Allen). — The earthquake was one abrupt shake which gradually died out, lasting 4 seconds in all. The weight to the clockwork which turns the light thumped back and forth in the weight-well from north-west to southeast, and the window weights did likewise.

In Ventura County a slight shock was reported at Newberry Park, Punta Gorda, and Ventura. At the latter place, hanging objects were observed to sway from east to west.

*Calabassas* (H. H. Wheeler). — A farmer stated that a number of cisterns for collecting rain-water for domestic uses were cracked by the earthquake shock so that they leaked.

*Santa Monica, Los Angeles County* (T. H. Moody). — A disturbance was noticed which seemed to be on the front porch, the noise continuing with considerable regularity, and appearing to change from place to place. Then there was other cracking around the house, and finally all was quiet. Nothing moved out of place.

*Los Angeles* (J. D. Hooker). — There was a light shock, then a heavier; then a smart shock which caused windows and doors to rattle. A window curtain swung in and out. A brass ring attached to a cord 15 inches long swung northwest and southeast. At the Weather Bureau station the barometers were observed to swing and rattle against the rings which confined them. The shock was also reported as a slight one at Azusa, Claremont, and Toluca, in Los Angeles County.

*Anaheim, Orange County* (J. F. Walker). — Very few people in Anaheim report having felt a shock at all. It was very slight. No clocks were stopt.

*San Bernardino* (Dr. A. K. Johnson). — The shock was sufficient to stop the town clock at 5<sup>h</sup> 17<sup>m</sup>, and several persons felt the vibrations, but no movable objects were displaced. At 4<sup>h</sup> 30<sup>m</sup> P.M., April 18, a slight oscillation was felt which caused the chandelier to sway. This movement continued for a few seconds, and seemed to be from north-west to southeast.

#### BAY OF SAN FRANCISCO TO THE SAN JOAQUIN VALLEY.

In Contra Costa and Alameda Counties the destructive effects of the earthquake were most manifest in the cities of Berkeley, Oakland, and Alameda, on the east side of the Bay of San Francisco,

*Berkeley* (A. C. Lawson). — A large majority of the brick chimneys were broken or overthrown, and in addition to this several brick buildings had their upper walls thrown down or were otherwise damaged by cracks. The most notable cases of this kind of damage indicative of the intensity of the shock may be briefly mentioned.

At the State Institution for the Deaf, Dumb, and Blind the upper part of the northwest tower of the building, to the north of the central structure, was wrecked by a considerable



A. Berkeley. Institute for Deaf, Dumb, and Blind. South wing, A. O. L.



B. Berkeley. Institute for Deaf, Dumb, and Blind. Herth wing, A. O. L.



A. Berkeley. Barker Block. Shattuck Avenue and Dwight Way. A. O. L.

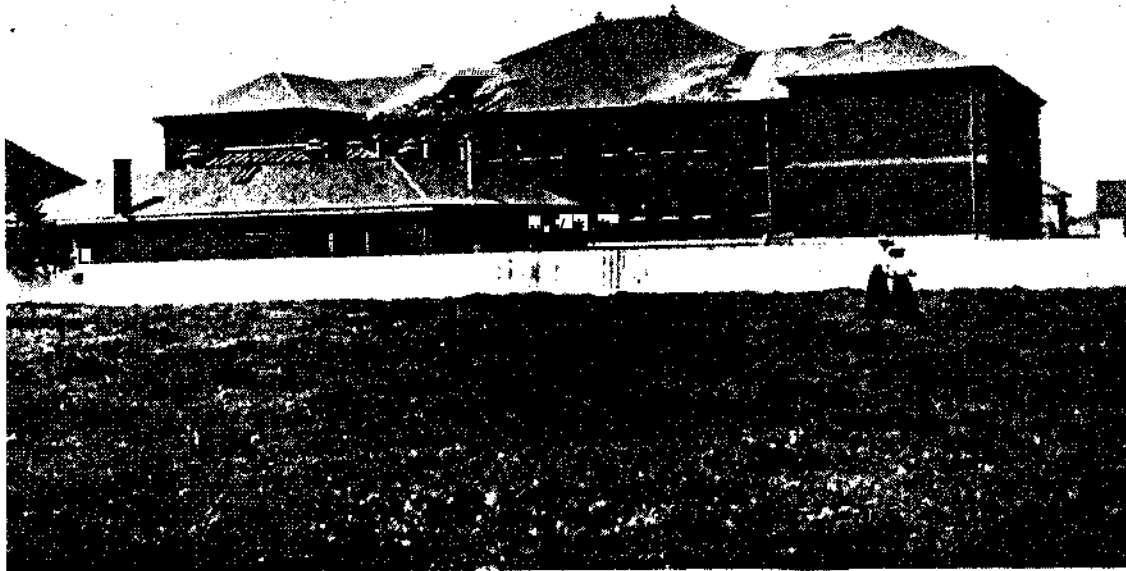

B. Berkeley. High-uliooL A. O. L.

part of the brickwork being thrown out on the northeast and northwest corners of the tower. (Plate 118B.) The upper part of a brick gable in the central building, facing northerly, was thrown southerly, or into the building. The upper part of the tower on the northwest corner of the building to the south of the central structure was demolished. (Plate 118A.) The main clock tower of the Institution, however, suffered no serious damage. The clock, a very unreliable one, stopt at about 5<sup>h</sup> 13<sup>m</sup>. At the High School the walls of the upper story, particularly those facing west, were badly cracked and partly thrown out, so that they had to be taken down. Two large brick chimneys on the east roof collapsed and did much damage to the rooms below. (Plate 119B.)

The Barker Block, at the northwest corner of Shattuck Avenue and Dwight Way, a building veneered in part with brick, had a great deal of the brick facing of the upper part of the building, and much of a strip of tiling above the east wall, thrown down. (Plate 119A.) The upper part of the rear wall of the brick building at the northeast corner of the same streets was thrown down. The north wall of the new Masonic Temple, which was in course of construction at the corner of Shattuck Avenue and Bancroft Way, was thrown to the north and caused the collapse of certain steel girders resting upon it.

The intensity of the earthquake within the city of Berkeley was by no means uniform. There were areas which seemed to a very considerable extent to be immune to the destruction so marked in the throw of chimneys, etc., in neighboring areas. The buildings on the University campus, for example, sustained no serious damage, and there was not a single chimney thrown, altho one or two were cracked. In a belt of the city extending northwesterly from the vicinity of the President's residence on the campus, the damage to chimneys was similarly light. This comparative immunity to destructive shock appears to be associated with the fact that the buildings on the campus, and in the belt to the northwest of it, are practically founded on rock, whereas the portion of the city where chimneys generally fell is on alluvium.

The direction of the fall of chimneys at Berkeley, as elsewhere, was controlled to a large extent by the orientation of the houses. Chimneys usually fell nearly at right angles to the longer side of their cross-section, which was as a rule parallel to one of the walls of the house. Notwithstanding this fact, however, there was a prevailing tendency in the fall of chimneys to the south and east, or in the southeast quadrant. Where chimneys fell to the east, they fell usually a little to the south of the line at right angles to the north and south wall; and where they fell south they fell similarly a little to the east of the normal to the east and west wall. Some square chimneys fell diagonally to the southeast. This was true of a rather massive 4-flue chimney on the writer's house, which fell at the latter end of the shock. In many cases chimneys were dislocated and twisted, without being thrown down. Of 38 chimneys, the rotation of which was noted by observers giving their entire attention to the matter for the time being, 31 were rotated counter-clockwise and 7 were rotated clockwise. In some parts of Berkeley the rocking of the houses was sufficiently violent to make it difficult, and in some cases almost impossible, to stand on the floor without support.

According to the observations of the writer, there were two maxima in the shock, with a lull in the interval, the second being the more violent. The movement appeared to be diagonal to the rectangle of his house, the longer side of which is approximately east and west. The throw of objects was much more to the west than to the east. This was well exemplified by the behavior of objects in the mineralogical museum on the third floor of South Hall. These are upright cases reposing on cabinets of drawers. The shelves, arranged in steps, are orientated north and south approximately, and face both east and West. On the shelves facing east very little was disturbed, while in those facing west



many of the heavier specimens, weighing 20 pounds or more, were projected from the largest, or top shelf, thru the glass doors, and were found strewn on the floor. In no case, however, was the glass of the doors broken. The latter had been forced open at the same moment that the masses of rock had been hurled toward them, thus allowing the missiles to pass thru. Smaller specimens, weighing less than a pound, on the shelves immediately below the top one, were very little disturbed.

*Oakland* (A. C. Lawson). — The destructive effects of the earthquake were much more in evidence in Oakland than in Berkeley, and this is doubtless due in large measure to the much greater number of brick and masonry structures susceptible to this kind of damage. When particular instances are considered, however, it seems probable that the severity of the shock was in reality somewhat greater in Oakland than in Berkeley. Chimneys fell very generally thruout the city; the upper parts of brick walls, gables, and cornices were in many cases thrown down (plate 122B) and cracks in walls were numerous. The underpinning of some few old frame houses caused these structures to collapse. In addition to this damage, which indicates fairly well the prevailing intensity of the shock, there were several cases of more severe destruction which must be noted.

The Prescott school, in course of erection, at the corner of Ninth and Campbell Streets, was rather badly wrecked (plate 121B), as was also the building of the California Flax Works, on the corner of Union and Third Streets, the walls of which gave way, causing the roof to collapse. (Plate 121A.) The susceptibility of this building to destruction was probably due to lack of transverse bracing for the walls, except that supplied by the roof girders. The southeast tower of the First Baptist Church, on Telegraph Avenue, had its upper northeast corner thrown out, and was otherwise wrecked. (Plate 122A.) The east and south gables were both thrown out; but the lower towers at the northeast and southwest corners of the building were comparatively unaffected. The Central Bank building, at the corner of Fourteenth Street and Broadway, had the brickwork of its southwest corner thrown off from the 2 upper stories, and was similarly affected, tho to a less extent, on its northwest corner. (Plate 120A.) The large smoke-stack at the Key Route power generating plant, built on the tidal marsh land, had its upper third thrown off. (Plate 120B.)

Considerable damage was also done to the First Unitarian Church, at the corner of Castro and Fourteenth Streets, and to the Christian Science Church, at Franklin and Seventeenth Streets.

(E. C. Jones.)—There were very few breaks in cast-iron gas-mains. Two of these were caused by impact of heavy debris falling from buildings and poles. One was on Washington Street, where heavy blocks of sandstone fell from the third story and the roof, breaking the main 30 inches below the bituminous rock. Another was at the corner of Fourteenth Street and Broadway, where a transformer fell from a pole, striking the center of a short car rail and bending up both ends. A 3-inch cast-iron main a short distance from this was broken at right angles. On the Twelfth Street dam, a cast-iron pipe was broken and displaced over a foot; while the high pressure steel pipe paralleling it was practically undisturbed. Gas-holders were uninjured, tho much of the water was thrown out of the holder tanks. The only damage to buildings was the destruction of brick gables at Gas Station "B," First and Market Streets.

*Oakland cemeteries* (R. Newcomb). — In the Mountain View Cemetery, which is on a little draw between ridges, the chief damage done was the cracking of the receiving vault, and that was not injured very much.

In St. Mary's Cemetery, on the small ridge to the west, however, many monuments were moved or twisted and several were overthrown. On entering the cemetery from the east, very little damage was observed, but on climbing the ridge more and more was noticed. On the north slope *hss* damage was done, and on level ground farther north

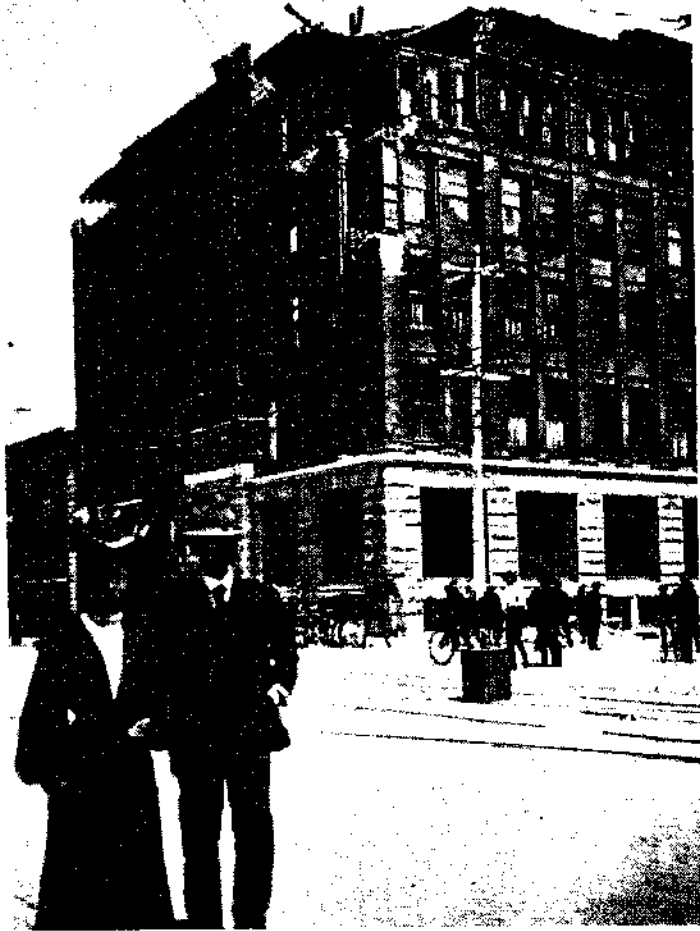

A. Oakland. Central Bank Building. G. K. G.



B. Oakland. Smokestack of power plant, Oakland Traction Company. A. S. E.

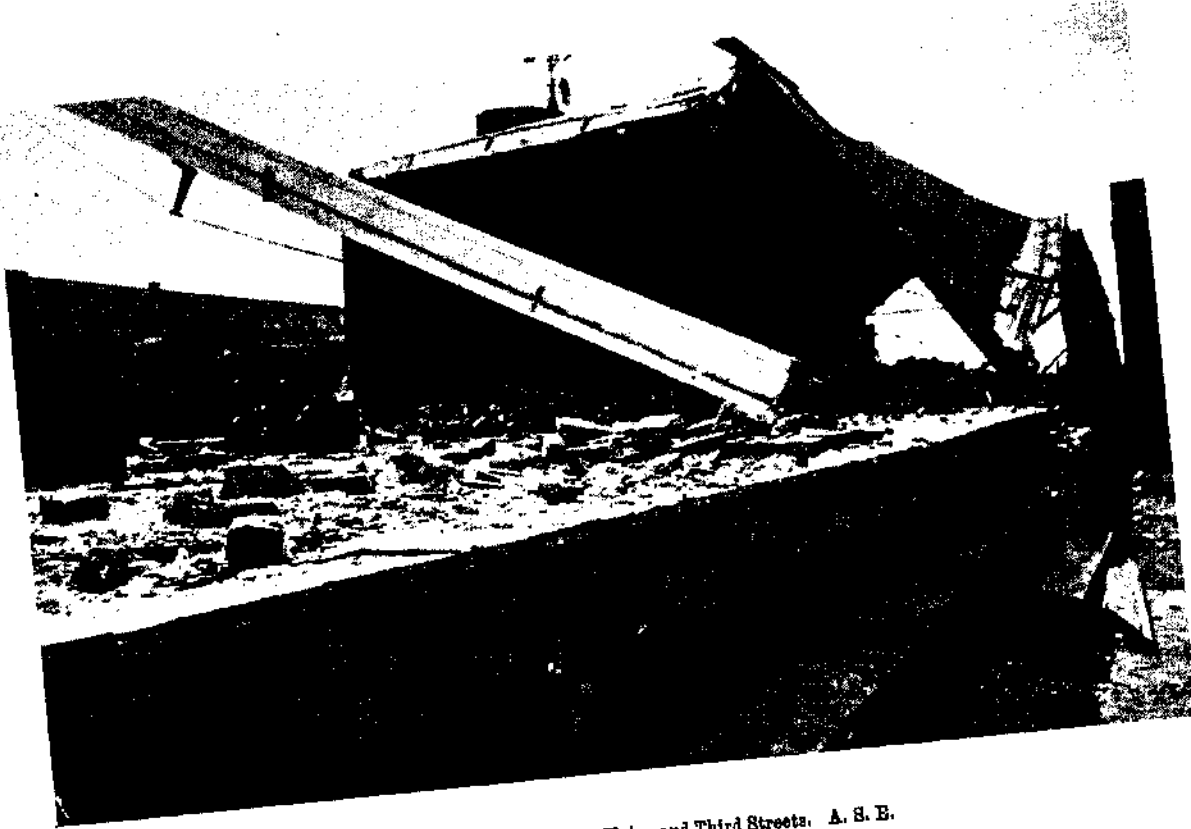

A. Oakland. Flax works, Union and Third Streets. A. S. E.



B. Oakland. Prescott School, Ninth and Campbell Streets. A.S.S.

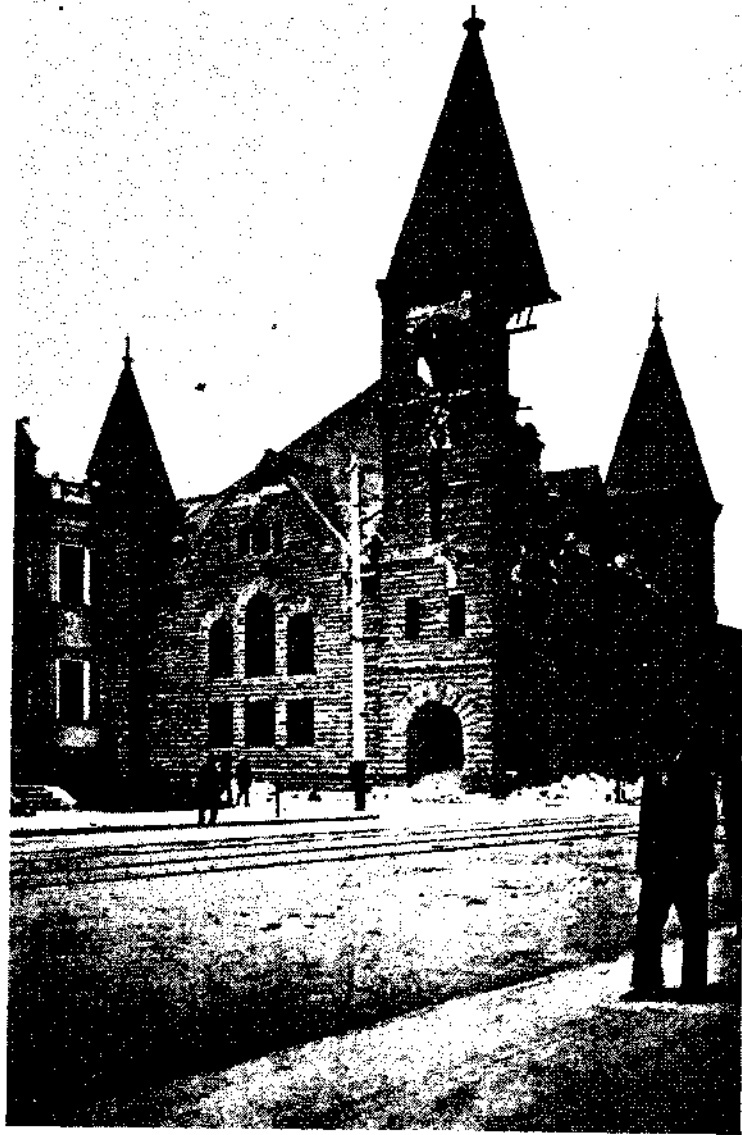

A. Oakland. First Baptist Ohnrch, Telegraph Avenue. & K. G.

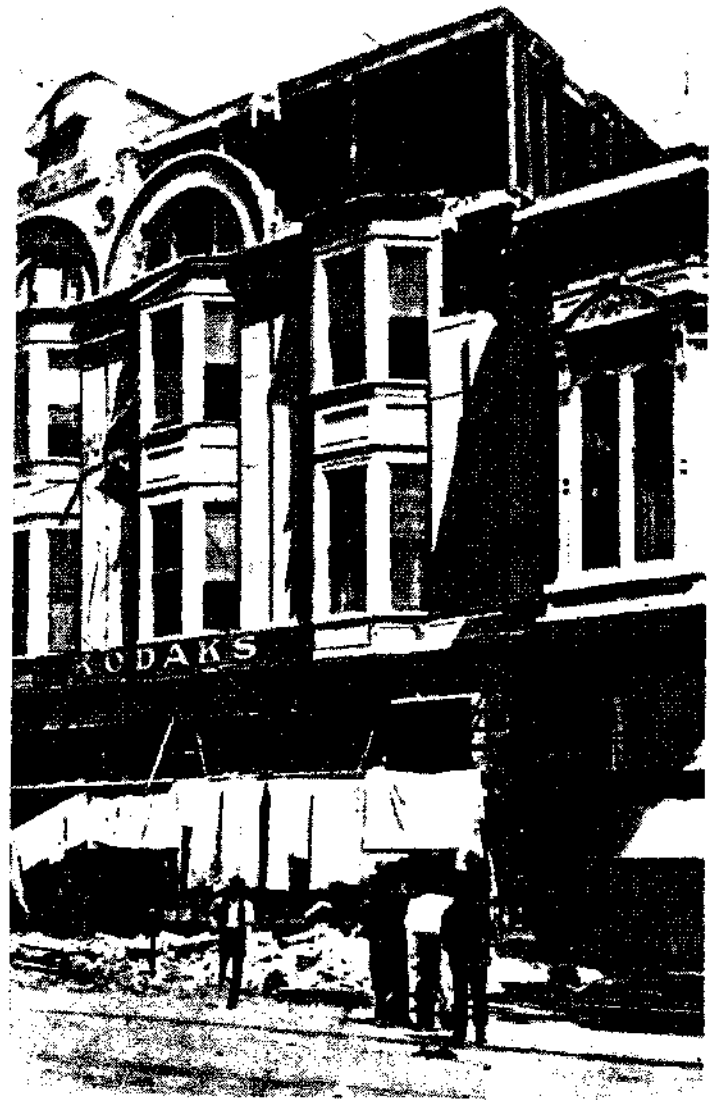

B. Oakland. Fourteenth Street, between Washington and Broadway,

absolutely no monuments were affected. Near the top of the ridge many monuments were overturned, and nearly all of them showed twisting or shifting. The result of the shock upon the monuments in this cemetery may be summarily stated as follows:

Fifteen were rotated counter-clockwise, 4 of these thru from  $1^\circ$  to  $2^\circ$ ; 6 thru  $5^\circ$ ; 1 thru  $15^\circ$ ; 3 thru from  $5^\circ$  to  $8^\circ$  with a lateral shift of 1 inch to the east; and 1 thru  $8^\circ$  with a lateral shift to the south.

Six were rotated clockwise, 2 of them thru  $25^\circ$  to  $30^\circ$ ; 1 thru  $15^\circ$ ; 1 thru  $10^\circ$  with a lateral shift of 6 inches to the south; and 2 thru  $2^\circ$  with a shift to the south of 1 inch.

Six fell to the east, 1 to the west, and 1 to the north.

Three were shifted laterally from 0.5 to 1 inch to the east, one 1 inch to the southwest, and one 1 inch to the south.

(B. McGregor.)—Of 12 monuments in Mountain View Cemetery that were disturbed by the earthquake, 10 are rectangular shafts which were simply twisted on their bases, 4 from left to right and 6 from right to left. The other 2 are turned shafts, both of which slid on their bases about 2 inches south. There were a few others displaced.

*Alameda.*—The destruction was confined for the most part to the throw of chimneys and the upper portions of brick walls. A few tanks were also overthrown, and 3 large stacks near Pacific Avenue and Lina Street. Messrs. Pond and McFarland counted 619 fallen chimneys in the city; of these they report that 189 fell to the southwest, 143 to the southeast, 93 to the northwest, 97 to the northeast, 34 to the south, 14 to the north, 25 to the east, and 24 to the west.

The fall of chimneys was evidently determined largely by the orientation of the houses, which have their walls in nearly all cases orientated at right angles to the direction given for the fall. The statistics are quoted not because they have any special significance, but because they indicate how little this class of phenomena contributes to the elucidation of the character of the earth movement, unless each particular case is studied in all its bearings.

With regard to the chimneys which were dislocated and twisted, there appears to be more constancy of result. The same gentlemen counted 61 such chimneys and of these 58 were rotated counter-clockwise and 3 clockwise.

*Southeast of Oakland* (G. Backus and R. P. O. Newcomb).—In the vicinity of High Street about half of the chimneys fell. The most general direction of the fall was to the north and south, altho some fell east and west when the slope of the roof was in that direction. Plastering in the houses was severely cracked, but no foundations nor buildings were damaged to any visible extent. A large smelter chimney in the vicinity was not damaged by the shock.

At Fitchburg about the same state of damage was seen. The chimneys on the old houses were gone. A large school-house with a brick foundation was not injured.

At Elmhurst the windows in the hotels and stores were broken. Most of the chimneys had fallen, one in particular being thrown to the east against the slope of the roof.

At San Leandro half the windows in the stores were broken, and nearly every chimney was down. All loose objects in the houses, such as dishes, etc., were thrown down. The plastering was greatly cracked. The houses were not seriously damaged, and only 2 have been condemned.

At Junction City the shock was about the same as at San Leandro. According to rumor a 3-inch fissure opened up between Junction and San Lorenzo, but this was not seen.

The County Hospital, but a short distance from the Junction, was only slightly damaged. None of the chimneys were thrown over and plastering was not cracked. The Hospital is built on solid ground, and several quarries can be seen in the ground upon which the buildings are situated.

At the San Lorenzo Cemetery, about half the tall monuments were down. Most of these fell to the south, some to the north, and a few to the east and west. Twisting occurs where the south end is thrown east. Almost all the chimneys in this vicinity were down.

At Mills College about half the chimneys were down. A stone building there was badly shattered and will have to be taken down. A brick and concrete library, and the same kind of a bell-tower, were not injured to any great extent, tho a few cracks can be seen here and there. Mills is on rather high ground at the base of the foot-hills.

(J. Keep.)—The floor of my room at Mills College seemed to be boiling. Immense damage was done. In the made ground there was a drop of from 1 foot to several feet. The seismograph registered for a time and then broke. The Science Hall, a stone structure, was badly injured, entailing a loss of \$5,000.

(J. N. Frank.)—In San Leandro objects against the east and west walls of the house were thrown down. Some statues were rotated clockwise. Chimneys were overthrown or broken, and plaster cracked, causing a damage estimated at between \$400 and \$500.

*Mount Eden* (William Gall).—The general direction of the movement was to the north and northeast, but objects fell in all directions. Objects were rotated, some clockwise and some counter-clockwise. A rotary motion was distinctly felt. Brick chimneys were broken and thrown. Furniture was thrown flat. The shock caused consternation among the people and domestic animals. Monuments in the cemetery were overthrown in various directions.

*Decoto* (F. E. Matthes).—No earth movements nor displacements were discovered anywhere along the base of the mountain scarp. The damage to buildings was slight, consisting of broken or twisted chimneys and cracking of plaster in a few houses. A few scattering chimneys escaped destruction, being probably better built than the average. In the stores and saloons articles were thrown down in southerly directions for the most part. Water was observed to splash from a tank a mile north of town, the direction of throw being southeasterly. The consensus of opinion was that the shock had a nearly north-south direction. According to the track-boss, the railroad track suffered no displacements anywhere between Niles and Irvington. The Masonic Home, a large brick structure located on the hillside on solid rock foundations, suffered but little damage. A few insignificant cracks in the brick walls, 2 chimneys broken off, and 2 chimneys cracked constitute the most serious damage. Plaster was cracked in several rooms; no windows were broken.

*Alvarado* (F. E. Matthes).—The Alameda Sugar Company was the chief sufferer. The main buildings of the plant are of wood, substantially constructed, and were not damaged; but the fittings and accessory structures were injured in numerous places. An old lime-kiln showed diagonal cracks in the brickwork; several of the small arches above the fire holes opened and let bricks fall out. A 6-inch cast-iron water-pipe, attached vertically to the main building, broke transversely about 30 feet above the ground. The water in the tanks on the roof splashed so heavily as to raise and break the wooden covers. The water seems to have splashed mostly to the east. The 2 great platforms carrying the molasses tanks, supported by numerous vertical props 10 feet 10 inches high, resting on concrete foundations, fell down altogether; the northern one to the north, the southern one to the south, these directions probably being determined by the original inclination of the supports or the relative efficiency of the bracing. The tanks were all damaged and over 1,000,000 pounds of molasses flowed away. The total weight on the south platform was 1,072,891 pounds. (Plate 115A.) In the engine-room the vertical steam-pipes cracked next to the flanges by the wracking motion of the ceilings thru which they extended. The shock appears to have had a north-south direction, according to the position of the breaks in these pipes.

The mill stands on flat, alluvial ground 100 feet north of Alameda Creek. Along the banks of the latter a large number of cracks extend, roughly parallel with the stream. Considerable masses next to the stream-bed slumped toward the same, leaving gaping cracks 1 to 2 feet wide, and carrying with them small outlying buildings, notably the fire-engine house, which moved bodily, concrete foundation and all, 2 feet south toward the creek. A small railroad trestle southwest of the mill moved 4 inches south on both of its abutments, probably owing to slumping of loose ground on the north side of the creek. A 2-inch water-pipe, laid under the ground some 60 feet north of the creek and almost parallel with the same, shows indications of having been submitted first to tension, causing rupture at one of the joints, then to sudden compression, causing it to be jammed together with violence.

Cracks in the ground may be found as far as 250 feet from the creek. They were nearly all closed at the time of the visit (May 7), but were easily traced by the streaks of bluish-gray sand which has issued from them, together with considerable quantities of water. According to the Chinese cook of the superintendent, the cracks nearest to his dwelling' opened and closed several times in succession during the quake; and large volumes of mud-laden water gushed from them, splashing up some 10 feet in the air at each closing. A large crack of this kind opened under the northwest corner of the dwelling, and the superintendent estimates that fully 500 gallons of water gushed from it, the flow continuing with decreasing volume for about an hour. The fence in front of the house shows that the ground there has been raised into a low hump. The sewer pipe leading west to the creek was detached from the house by a space of 22 inches. A chimney near the northeast corner of the house was thrown to the east with sufficient violence to throw the farthest bricks 35 feet east of the house. The top of the chimney was only 20 feet above the ground originally.

In the roadway south of the mill, water oozed out in a number of places, without the production of visible cracks. The water pipes and hydrants in this vicinity were crushed in several places.

At the Alvarado Water Works the brick buildings suffered considerable damage, the walls cracking in several places. Nothing could be learned regarding the behavior of the wells of this plant. The frame dwelling of the superintendent was damaged by the collapse of its underpinning. A similar fate befell the Alvarado Hotel. Both houses were being put in place at the date of the visit. At the school-house the water-tank fell owing to the collapse of its supports.

Nearly all brick chimneys in the village fell, the directions varying. A few cracks opened across the streets, but these had been filled on the date of the visit. The consensus of opinion was that the shock had a north-south direction.

*Lick Observatory, Mount Hamilton.* — From the reports of astronomers C. D. Perrine, R. G. Aitken, H. K. Palmer, K. Burns, A. M. Hobe, and G. A. Vogt the following observations as to the character and intensity of the shock have been obtained. The principal disturbance was preceded by a tremulous motion variously estimated at from 11 to 15 or 20 seconds. There seemed to be 2 maxima, the first being the stronger (?), according to H. K. P. There was a first secondary maximum about 5 seconds after the beginning, a maximum 11 seconds after the beginning, and another secondary maximum about 15 or 20 seconds after the beginning, according to K. B.

A tremulous motion was felt after the principal disturbance.

"Heavy vibrations were still felt 60 seconds after the first count. Motion was felt for nearly 2 minutes after the first count." C. D. P. "The duration of this tremulous motion was about 30 seconds. Vibrations stopped in the house at the end of that time." K. B.

"Duration between 30 and 35 seconds." A. M. H.

No vertical motion was perceived, nor was any recorded on the Ewing seismograph.

According to C. D. P., the heaviest movement seemed to be nearly east and west; while according to K. B. it was northwest and southeast. On the Ewing seismogram, the north and south component seems to be the most violent, the pen having left the plate for half a revolution of the plate. The east and west vibration was extremely large. The maximum of the east and west movement occurred after the pen of the north and south component left the plate.

A razor strop hanging on a north wall, the only thing free to swing, swung east and west about a foot (double amplitude). A shaving brush which stood up on end and, being round, could fall in any direction, fell west. Things overturned fell east and west.

The shock was severe enough to make windows rattle and doors swing. Book-cases were moved out about an inch from east and west walls, but not from north and south walls. A pendulum clock on a north wall stopt at 5<sup>h</sup> 12<sup>m</sup> 52<sup>s</sup>\*. Not much plaster fell, and only 1 of a dozen or more chimneys was thrown. Some other chimneys, principally those of a 3-story brick house, were cracked and shifted.

The earth-waves were very long, but smooth.

According to K. B., the shock was accompanied by a sound as of the flight of birds.

The water in Smith Creek on the afternoon of the day of the shock was of a light slate color; not yellowish, as after heavy freshets.

"Standing in the doorway and looking out the east window, I could see the walls of the brick house shaking. There seemed to be a great deal of dust in the air in front of the window." H. K. P.

The movement of the east-west component of the Ewing seismograph indicates an intensity corresponding to an acceleration of 400 mm. per sec. per sec. The north and south pen left the plate, owing to the violence of the shock.

*Niles* (R. Crandall).—The town of Niles stands on gravels of the alluvial fan at the mouth of the Niles Canyon, and is about 20 miles due east of the fault at its nearest point. At Niles there were no large buildings, and most of the structures were not strong, but there was no serious damage done to any of them. About 56 per cent of the houses had either terra-cotta chimneys or tin pipes, which are much harder to shake down than those of brick. Of all the chimneys in town, 48 per cent fell; of the brick chimneys 80 per cent fell; of the terra-cotta chimneys only 10 per cent went down.

Most of the houses were not plastered, so no notes could be obtained on that subject. In nearly all of the houses such objects as dishes, bottles, vases, and clocks were thrown from the shelves. Milk and water were spilt from open receptacles in most cases.

A concrete abutment of the bridge across Alameda Creek was cracked. A man out of doors at the time found much difficulty in walking. A 50,000-gallon water-tank fell at the Niles railway station. Similar tanks were thrown down at the stations at Pleasanton, Livermore, and Lathrop. This was due to imperfect construction rather than to the violence of the shock. The tanks were upon cast-iron pillars originally, but when new and larger locomotives were put into service on the railway, it was found necessary to have the water-tanks set higher. This was accomplished by inserting short blocks between the tanks and the tops of the pillars. When the weight of 200 tons was swayed on this sort of a structure, the tank collapsed.

While at Niles, a visit was made to one of the new tunnels of the Western Pacific Railway, which is about 1 mile east of Niles in the Niles Canyon. The tunnel had penetrated about 130 feet into the hillside, but had not yet past thru anything but a sandy clay. During the previous winter the walls at the portal, and also on the inside, had stood without timbering. Since the earthquake it had been impossible to break out more than 4 feet of ground ahead of the timber sets without caving taking place. There had been an apparent movement in the soil which had removed its consistency and made it incoherent. The amount of water present in the tunnel was perceptibly changed. The foreman said



that there was more water since the shock than there had been even in the wettest part of the winter.

*Sunol* (R. Crandall). — Sunol is a small town in the north end of Sunol Valley. The intensity of the earthquake there was of especial interest, because the town lies almost upon the line of the Sunol fault. This fault is the largest one known in the Mount Hamilton range, and has a northwest-southeast trend parallel to that of the San Andreas fault. It was expected that some compensating movement might be found to offset the slip along the San Andreas fault, and this Sunol fault was considered the one most likely to show that compensatory movement. The town stands partly on gravels and partly upon hard sandstone. The gravels are quite firm; much more so than the gravels on which the town of Niles is built. The gravels at Sunol are not thick, and the foundation is much firmer than that at Niles. It was quite apparent that Sunol had not felt the shock as severely as it had been felt at Niles, 6 miles to the west, or at Pleasanton, 6 miles farther east. Only a small percentage of the chimneys fell. Of other objects, few except bottles and vases fell; and a window was broken at the post-office. As there was no movement along the Sunol fault, the intensity at Sunol was less than at Niles, but the fact that it was also less than at Pleasanton shows that the difference must be in the formations underlying the two towns.

(F. E. Matthes.)—Over 75 per cent of the chimneys in Sunol were broken. Some were twisted in a clockwise direction, while others were apparently thrown straight, most of them to the east. Many chimneys were cracked but were still in place. A few windows were broken, notably those of the post-office. The town is on alluvial ground, close to the hills. The depth of alluvium is estimated at the creek-bed to be about 50 feet. The steel bridge southeast of the town was found entirely undamaged. The flume between Sunol and Niles was damaged at a point 2.5 miles below Sunol. A few boards were knocked out of place, but the damage was slight and quickly repaired. The Apperson house, a substantially built structure with strong chimneys, had two of the chimneys twisted and one left intact.

*Verona* (F. E. Matthes). — All the chimneys on the main house of the Hearst residence, 6 in number, were cracked, but none was thrown down. The studio has a long crack running immediately above the projecting beams supporting the roof, along the northeast wall, 18 inches from the eaves. No damage was occasioned to plaster or walls, except in the studio. The chimney of the power-plant, at the foot of the hill, was found cracked. The "cottage," built of wood, suffered no damage. No windows were broken.

*Pleasanton* (R. Crandall). — The town is on a flat valley-floor composed of gravels, apparently the same as those at Sunol, but of a later age. Probably the Sunol gravels washt down from the hills to form a valley-floor. The ground upon which the town is built, then, is similar to that at Niles. The shock was felt quite sharply at Pleasanton, but not so much so as at Niles. Such articles as vases, clocks, and dishes fell in most cases and milk and water were spilt from open vessels. Practically no plaster fell, but houses that were plastered had numerous cracks in the walls.

The intensity, as shown by falling chimneys, was as follows: 30 per cent of all chimneys fell; 48 per cent of the brick chimneys fell; 30 per cent of the chimneys were terra-cotta, but only 3 per cent of these fell; of the brick chimneys which did not fall, 30 per cent were cracked.

(F. E. Matthes.)—About 50 per cent of all brick and tile chimneys in Pleasanton were thrown down. No marked preponderance in any one direction was noted. Nearly every brick building in town was somewhat injured. Cracks in the masonry and the dislodgment of occasional individual bricks in arches above windows and cornices constitute the principal damage. The only stone house, a 2-story saloon, suffered more severely than any of the brick buildings, the walls being badly cracked at the corners and even

partly thrown down at the northwest corner. Wooden houses suffered no damage except the cracking of plaster. No window panes were broken.

Two bridges near Pleasanton were inspected, one north of the town over Arroyo Valley and the other over Arroyo de la Laguna, 1.5 miles west of the town. These bridges rest on concrete abutments, and examination showed that in both cases the concrete had sheared horizontally by the longitudinal oscillations of the superstructure. The cracks were about even with the lower side of the stringers. In the case of the first bridge mentioned, these cracks extended to the wing wall at the south end. A vertical crack was also found near the west corner of the south abutment, running thru the entire height of the structure. A similar crack was also found at the east corner of the north abutment. The disposition of these vertical cracks seems to indicate torsional movements of the bridge, with right-handed rotation. The concrete was of poor quality, being traversed by streaks of coarse gravel alternating with others of finer texture.

Thru the courtesy of F. H. Tibbets and Harold Woods, surveyors for the Pleasanton Hop Company, access was obtained to their records on well borings made in the neighborhood of Pleasanton. Most of these borings did not reach bedrock, but 2 of them did: one near the graveyard south of Pleasanton, which strikes disintegrated shales at a depth of 275 feet; the other 0.75 mile northeast of Pleasanton, just south of the railroad track, which strikes similar material at a depth of 180 feet.

*Livermore* (F. E. Matthes). — Many chimneys were cracked and about 50 per cent thrown down. Several tall brick chimneys in various parts of the town were left intact. Those on brick piers between Livermore and Pleasanton were undamaged. A block of old, weak-looking buildings northeast of the depot suffered no more than a few cracks. Glassware in saloons and bars was thrown to the floor in quantities, in various directions. A heavy water-tank at the depot fell, owing to weakness of supports. The direction of the fall is north, but this is not necessarily indicative of the direction of the shock, as the wooden support probably gave way piecemeal. Concrete bridges about town were unhurt. The town is on alluvium.

An interesting feature appears 0.25 mile north of Meyn's ranch, west of the road leading north from Livermore, about 2 miles north of that place. It is on the summit of a smoothly rounded hill, sloping gently down to an even, peaty meadow traversed by the arroyo of Cayetana Creek. The hill is really one of a number of spurs of the higher land south of the meadow. Its soil is peaty, with many sun cracks due to recent drying. Deep cattle tracks show that it must be quite soft in wet weather, much like the adjoining meadow. The summit of the hill in question was found crowned by a series of concentric deformations, rising stepwise above one another. A number of nearly concentric cracks were found extending northward into a sort of panhandle, along each of which an upward movement of the soil had apparently taken place. The uplift along the 2 principal cracks was found to be 19 and 16 inches, respectively. Along the minor cracks the vertical displacement amounted to an inch or two only. The surface of each step or bench was found to slope inward, and in some places the edge even appeared to have curled inward. The material must have been wet and more or less plastic at the time of the disturbance, but has since dried and hardened, as peaty soil will in dry weather. While the phenomenon is described by many as a "mud flow" or "mud spring," there are no indications whatever of a "flow," strictly speaking. The inward slope of the raised benches suggests the dropping back of the central portions after their upheaval; the scarps remaining, probably, owing to the friction between the opposite walls of the fissures, which prevented the complete return of the adjoining edges to their former level. The concentric arrangement of the cracks seems to indicate a centralized upward thrust, and the small diameter of the entire deformation shows that the effect of the thrust rapidly decreased away from the center. While there is no rock visible, it is quite possible

that the hill has a sort of rock-core, some distance below the surface. The shock felt at Meyn's ranch was not particularly violent and caused no damage to the buildings. (See plate 141A.)

(R. Crandall.)—Geologically, Livermore is on a floor similar to that of Pleasanton, but geographically it is about 6 miles farther east and farther from the San Andreas fault. The shock at Livermore was not severe, and but little real damage was done. A few objects of unstable nature fell, and in the larger number of cases milk and water were spilt from open vessels, but not in all cases.<sup>1</sup> Most of the houses in town were not plastered, but only a few of the plastered houses had the walls cracked, and in only one case was plaster known to have fallen.

An excellent opportunity was afforded to see the effect of the motion upon pendulum clocks. In one jewelry store every such clock stopt, regardless of the direction in which the pendulum swung. One clock which had not been running before the earthquake, was started. Its pendulum swung in a northwest-southeast direction, as in the case of several clocks that stopt. About 5 per cent of the brick chimneys fell, with less than 15 per cent cracked.

A curious phenomenon was observed near Livermore, the explanation of which is not clear. At the Alviso ranch, a little over a mile north of the town, the top of a small hill was broken up at the time of the earthquake. The breaking of the ground did not consist of fissuring along a line, but was in the nature of an uplift of a limited area. There were 3 fairly well marked concentric rings where the ground had broken, the inside ring in each case being forced higher than the outside ring. The effect was similar to that obtained by placing 3 plates of different sizes within each other. The accompanying photograph (plate 141A) shows this feature fairly well. It was said by people in the vicinity that there was mud in the cracks at the time of the earthquake, but there were no evidences of any at the time of the writer's visit several weeks after the shock.<sup>2</sup>

(Elmer G. Still.)—The Southern Pacific Company's 20,000-gallon water-tank fell in a north-northwest direction; tombstones fell in various directions; a hanging lamp was caused to swing counter-clockwise, with the longer diameter of its orbit east and west. Mr. Still was asleep and was awakened by the bed being shaken north and south; the motion after that was in every direction. Water spilt from full tanks mostly on the east and west sides. Mr. Still reports that where the ground was deformed in concentric ridges, as described by Mr. Matthes and Mr. Crandall, there was an alkaline spring years ago.

*Santa Rita*, 3 miles east of Dublin (F. E. Matthes). —A small, flat levee along the east bank of Tassajara Creek, immediately north of the main road, showed several somewhat crescentic cracks along which the ground had slipped down and toward the creek from 1 to 3 inches. These cracks extended farther south, according to local settlers, and cross the road; but this was no longer traceable at the time of the visit. Chimneys had fallen on all the houses, but as they were not of brick the damage was slight. In the grocery store and bar-room articles were thrown in a southerly direction.

*Dublin* (F. E. Matthes). —The damage consisted of a few chimneys broken off, and articles thrown down from shelves and counters. A water-tank 2 miles east fell from its supports, probably owing to the weakness of the latter. Several other tanks in the neighborhood were injured.

*San Ramon* (F. E. Matthes). —Most chimneys had fallen. San Ramon saloon, south of the bridge, slid off its foundations in a northerly direction. The west end moved 3 feet, the east end about 15 inches, being stopt by a fence-post. Several window panes,

<sup>1</sup> This may be contrasted with Pleasanton, where at all the houses visited there was only one where milk was not spilt.

\* A somewhat similar phenomenon was seen on Cahill's ridge in San Matco County, but there was nothing to suggest an explanation.

were broken in the building, and glassware was wrecked in quantities. Neither church nor school-house suffered any damage. The shock was mostly in a north-south direction.

*Danville* (F. E. Matthes).—Most chimneys were cracked or twisted; a few were broken off completely. Glassware in saloons and goods in a grocery store were thrown down in quantities in various directions. Water was observed to splash out from two tanks in the village, in a southerly direction in each case. Water-pipes laid over the surface of the ground at a neighboring ranch were reported to have been thrown out of alinement.

*Walnut Creek* (F. E. Matthes).—About 50 per cent of all chimneys were thrown down. A water-tank at the livery stable fell. Goods in the grocery store were thrown down in quantities. The direction of the shock was not ascertainable. Two barns, weak structures, were moved slightly from their foundations. Plaster in several houses was cracked.

*Clayton* (G. D. Louderback).—At the northern base of Mount Diablo the intensity of the shock was much less than in the alluviated valley-bottom at Concord. No chimneys were thrown down, and no dishes nor glassware were knocked off shelves, but milk in pans was skimmed by the rocking motion. On a hillside above Peach Tree Spring, on the west side of Mount Diablo and very near the contact of the Knoxville shales and the Franciscan, a crack opened in the ground about 30 feet long, in a north and south direction, gaping 4.5 inches.

*Concord* (F. E. Matthes).—Conditions here were much the same as at Walnut Creek. The only brick building, a bank, was cracked. Most of the chimneys were cracked, and about 50 per cent had fallen. A water-tank at the depot was thrown down.

*Martinez* (F. E. Matthes).—Most of the brick buildings here suffered severely; nearly all are more or less cracked, and the stone facing of several was partly demolished. The roofs of the bank and other buildings were wrecked. A small stone house, built of large blocks, was completely ruined, probably owing to vigorous vibrations of an adjoining wooden water-tower near the Alhambra Hotel. The stones started in the east abutment of Main Street bridge. Many window-panes were broken. Most of the chimneys were broken off. The court-house was little injured, except for the pediment above the entrance, where many large stones have been loosened. One of the chimneys of the Bull's Head Oil Works lost a corner; the others were left undamaged. The railroad track east of Martinez, near Bull's Head Oil Works, was thrown 3 inches out of alinement to the north. Many cracks occurred in the embankment on both sides of the track. A series of 5 small transverse waves was found in the embankment about 0.5 mile west of Peyton Station. The distance between crests was about 10 to 15 feet; amplitude estimated at 3 inches. This embankment lies in flat marshy land. A small railroad bridge near Avon Station was thrown 4 inches toward the east abutment, but it had been repaired at the time of the visit.

(W. Stoddard.)—Buildings were loosened in general, the fronts of some falling out. The north and south walls seemed to suffer most. Parts of a large wooden building, particularly the window-sashes, were moved in a southwesterly direction. The wooden props supporting another building were tilted a little toward the southwest. Another building was moved 0.5 inch toward the south. The southern part of the town was damaged more than the northern part. In the cemetery 6 slabs and pillars fell a little east of north; 2 pillars fell to the west; 2 pillars were twisted on their bases and shifted to the west; 1 pillar was tilted to the south immediately next one which fell to the east. A clock at the court-house had its pendulum broken. The pendulum was about 2 feet long. The level of the underground water rose after the shock.

*Cornwall and Black Diamond* (E. S. Larson).—The towns are about 0.5 mile apart, both located on the bay flat and underlain by a tough hardpan. A very few things

were thrown from shelves; one rickety chimney was thrown, and one concrete wall in process of construction fell. Less than half the clocks were stopt, though nearly all sleepers were awakened. Most of the houses are small and have terra-cotta chimneys.

*Antioch* (E. S. Larsen).—Antioch is on the same sort of ground as Cornwall, but there are more brick buildings and more moderate-sized builtlings with brick chimneys. A few chimneys were twisted on their bases, several were thrown entirely and about 25 per cent of them needed repairing after the shock. Out of about 12 brick buildings, the tower of the Catholic church was somewhat damaged, and one rickety old brick building fell. None of the good buildings were damaged. A couple of windows were broken, a few clocks were stopt, and a few things were thrown from shelves. Top-heavy statuettes tipt over. All sleepers were awakened. Things generally moved north and south, or northwest and southeast, which seemed to be the general impression of the direction.

*Bethany, San Joaquin County* (Mr. Schichtman). —The movement was from northeast to southwest, and was sufficient to splash water from a full trough, but not strong enough to overthrow objects.

*Byron Hot Springs, Contra Costa County*. — The springs, some 30 in number, hot and cold, were not affected by the earthquake. One chimney and some plaster were cracked and a picture was thrown from the wall. The shock was considered quite severe, though the damage was slight.

*Tracy* (R. Crandall). — Tracy, in the San Joaquin Valley, lies at the foot of the range separating Livermore Valley from San Joaquin Valley. The shock was not at all severe; in fact it was spoken of by several as being no heavier than the jarring often occasioned by heavy engines starting a loaded train. Very few objects fell, and in only one case was any damage done to a building. This was the cracking of a 2-story brick building which did not appear to be especially well constructed. Only one brick chimney cracked, and none fell; so it would appear that the building cracked because of the poor construction rather than because of the intensity of the earthquake. Milk or water was spilt in only few cases — not over 30 per cent. The water-tank of the Southern Pacific railroad at Tracy fell, as did similar tanks at Livermore, Pleasanton, and Lathrop. The reason for this is explained in the description on a preceding page of the construction of the tank supports at Niles.

*Lathrop* (R. Crandall). — This is a small town upon the floor of the San Joaquin Valley, about 12 miles east of Tracy. The intensity was about the same as at Tracy. There was no appreciable difference in the number of fallen objects or stopt clocks, the main difference being that a considerable number of people were not alarmed enough to get up. One man who was up experienced no difficulty in standing or walking. The general impression is that the shock was slightly lighter than at Tracy,

*Stockton* (R. Crandall). — Stockton is about 10 miles north of Lathrop, but not much farther east. As it is a much larger place, it was easier to see the effects of the earthquake. Not as much detailed work was done in Stockton as at the other places, since it was known that Mr. Edward Hughes was collecting data in that city. The shock was felt with alarm by people in houses and on the ground. The motion was spoken of as being a rolling motion like that felt on board ship. Almost no objects fell, even in houses where there were tall vases and similar brie-à-brae. At one drug store two little vials fell from the shelves; at another even built-up pyramids of various articles for window display were undisturbed. Milk and water were spilt in a very few cases. Splashing of milk up the sides of the pans was noted by a few persons, and the direction was given as northwest and southeast. Many clocks were stopt, but there was nothing consistent in the direction of pendulum motion. All of the big brick buildings were visited, and no damage was found except in an old 2-story building which seemed merely to have

had an old crack widened, due to the settling of the foundation. The City Hall had considerable plaster cracked, but this was due to the swaying of a 50,000-gallon tank on the roof. Three chimneys were cracked, and one was reported to have fallen, but this was not verified. At the houses where the chimneys were cracked, milk was not spilt from open pans, so it is apparent that the chimneys were faulty and not that the earthquake was severe.

(E. Hughes.)—A careful and exhaustive inquiry was made at Stockton by Mr. Edward Hughes, under the direction of Prof. J. C. Branner, and the following notes are contributed by him:

The shock, while strong enough to alarm many of our people, was chiefly notable for the absence of the destructive effects experienced in many less fortunate localities. It began with a gentle trembling motion, which increased slowly for the first 5 or 6 seconds, then rapidly to a maximum of rough jolting shocks lasting perhaps 5 seconds. These were followed by a series of long, smooth vibrations, which gradually decreased in amplitude until no longer perceptible. The effects, as noted by many observers, would indicate that the heavier shocks traveled in a northwest-southeast direction, while the smooth oscillations which marked the latter part of the disturbance ran nearly east-west. The immediate effects, as noted in dwellings, during the shock were the creaking and straining of buildings, the swinging of doors, the rattling of window weights and pictures on the walls, the swinging of chandeliers and drop-lights, and the stopping of clocks. Out of doors, some observers claim to have noticed the swaying of tall buildings and smoke-stacks; and many mention the violent motion of the trees, the branches of which lasht together as if in a storm. Birds frightened from their resting places flew in confusion, and the air was filled with their startled cries.

A careful canvass of the city gives the following results in the way of damages sustained: There were a few small cracks in the arches in the hallways of the county courthouse. It is safe to attribute this to faulty construction rather than to the violence of the shock, as a number of large cracks had opened in various parts of the building soon after it was finished. One water-tank was overturned, the supporting framework being insufficiently braced; this tank fell about 15° east of south.

A large gasometer at the natural gas well on north Commerce Street was slightly damaged. Castings supporting the guide wheels were broken, and the gas tank was slightly twisted to the left so that the guide wheels were thrown off the guides.

In two or three cases in the city, the tops of chimneys fell off. Examination showed that the mortar had never properly united with the bricks, owing probably to their dryness when laid. In several cases houses suffered damage by the spilling of water from attic tanks.

Aside from these cases of relatively insignificant damage, everything gives testimony to the comparative gentleness of the shock. In china stores, where fragile wares were displayed in all sorts of insecure positions, not a piece was displaced or broken. So far as can be learned, no plaster fell anywhere in the city, and there was no breakage of bric-à-brac or china in the dwellings. Observers who watched the minute hands of clocks that were not stopt estimate the duration of the shock at from 30 to 40 seconds.

The heavier shocks were undoubtedly from northwest to southeast. This was shown in several ways. Tanks spilt water in both these directions, and the tank noted above fell nearly to the southeast, although its frame ran approximately east and west, and so offered some resistance to free motion to the southeast. In McCloud's Lake, the waves ran northwest-southeast, breaking highest on the bank and bulkhead in the southeast corner, while the north side was little affected. At the city pumping station on Mormon Channel, a similar effect was noted. Several observers claim to have seen tall buildings and stacks swaying in the direction indicated, and those who were standing were con-

scious of the movement of their own bodies in the same direction. Milk in open vessels left a coating of cream highest on the northwest and southeast sides, although in many cases motion was also shown east and west.

While there is not entire agreement with reference to the east and west vibrations during the latter part of the shock, the larger number of observers plainly felt and saw their effects, and the evidence as to their occurrence seems conclusive. Doors swung east and west; swinging objects, such as drop-lights, hanging baskets, etc., were found either swinging east and west or in circles after the shock, and pictures hung on north and south walls of rooms showed lateral motion during the latter part of it. Tanks in several cases spilt water east and west, although not in such quantities as in the other directions.

The following table indicates the effect of the shock on the 128 clocks concerning which reports were received:

Orientation.	Number of Clocks.	Stopt.	Not Stopt.
Facing west . . .	32	17	15
Facing north . . .	3G	IS	18
Facing east . . .	27	13	14
Facing south . . .	33	IG	17
Total . . .	128	64	64

Clocks with very long or very short pendulums were generally not stopt. Two town clocks were not stopt. One of these, which, through the courtesy of Mr. E. B. Condy, 1 was permitted to examine, is in the tower of the county court-house. Its frame stands northeast and southwest; and its 100-pound pendulum, hung on the northwest side of the frame, swings northeast and southwest, missing the edge of the iron stand about 0.5 inch. A deep scar in the mahogany pendulum bar indicates that during the shock the pendulum swung sharply to the southeast, its bar striking the edge of the iron stand. The weights of the same clock hang in a narrow shaft at the side of the tower. The wire pulley cords which support the weights were found so badly twisted as to interfere with winding the clock a day or two after the earthquake. On the inside of many clock-cases are found scars made by the striking of the pendulums. These scars are deepest on the south side in clocks facing east or west, and on the west side in clocks facing north or south.

Some persons who were outdoors during the shock claim to have heard a dull rumbling sound immediately preceding it. They find it difficult to describe the sound accurately, and in some cases think it may have emanated from nearby buildings. A considerable number of people suffered from nausea and dizziness, with headache, for a time after the shock. With some these disagreeable symptoms persisted all the following day.

*Farmington,, San Joaquin County* (J. F. Gwin). — The house quivered, then the sash weights of the windows began striking back and forth, and a heavy rolling motion was felt which caused open doors to swing back and forth. The clock stopt. The surface of the ground moved in waves like water, and trees moved with the ground.

*Central San Joaquin County* (K. P. Higby), — In Ranges G and 7 E., townships 1 and 2 N., Mount Diablo Meridian and Base line, there were apparently 2 maxima of equal intensity with intervals of a few seconds between. The apparent direction was SW. to NE. No objects nor chimneys were overthrown. The bed shook, and chandeliers, pictures, open doors and shutters were caused to swing. Windows and window weights rattled. The clock diil not stop. Paper on the walls was cracked. The slate roof on a high church tower was cracked. There was scarcely a breath of wind, yet large trees swayed and bent ~~LS~~ if rocked by a terrible gale. Water in the wind-mill tank and in other tanks slept

over, and continued to do so for 5 minutes after the shock. Water was thrown from a swimming tank where the level was 5 feet below the top of the tank; water at one place in the river was thrown over a concrete wall 8 or 9 feet high.

*Modesto* (E. Hughes).—In common with other points in the great interior valley region, Modesto received a very decided shaking up by the earthquake, but suffered practically no damage. The local effects were the stopping of clocks, the swaying of trees, hanging baskets, drop-lights, and chandeliers; and in a few cases the fall of objects from insecure positions in stores and dwellings. Water tanks and troughs, milk pans, etc., spilt part of their contents, and in one or two instances cracks opened in buildings. No one, so far as known, actually timed the duration of the shock in seconds.

The observations of many persons in and near the town indicate that the vibrations were in two principal directions: viz., northwest-southeast and approximately west-east. The heavier shock seems to have been in the first direction, but observers are not in entire agreement on this point. Clocks of larger size were quite generally stopt, no matter in what direction they faced. Several persons report having heard a roaring or rumbling sound, beginning a few seconds before and continuing until the end of the disturbance; and a number of people were affected by symptoms somewhat like seasickness for several hours after it.

The following detailed notes were obtained from citizens of Modesto and vicinity:

(Mr. Schaffer.)—Trees swayed northwest-southeast. "The Swan," a new building with green walls, cracked at the junction of the ceiling with the northeast end wall; also at the junction of the ceiling with the fire-wall running thru the center of the building from northwest to southeast. The cracks in both cases were on the second (the top) floor. The building faces northwest.

(Player's Drug Store.)—Boxes on shelves on the northwest side of the store fell toward the southeast.

(Mr. Swanson.)—Saw water spilt southeast-northwest from the railway tank at the depot.

(Al Fogarty.)—Meat market. Mr. Fogarty ran from the building, and on returning after the shock he found drop-lights and a butchers' scale, suspended by a single wire from the ceiling, swinging in a direction parallel with the street, northwest-southeast.

(Green Brothers.)—Heard a roaring sound just before the shock. Felt the bed swing northwest-southeast. Plaster sifted down from cracks in the ceiling.

(E. E. Woods.)—Mirror hanging from southeast wall fell, on account of breaking of the cord, on its face toward the northwest.

(Mr. Chapman.)—Ranch 5 miles southwest of Modesto. Water trough oriented north-south spilt water from both ends.

(George T. McCabe.)—The bed was standing north-south. The first motion was east-west, the second and maximum motion was northwest-southeast. Trees swayed northwest-southeast. The window sash dropt.

(Mr. Rider.)—Water in the street gutters moved west-east in the first part of the shock; in the second part, northwest-southeast.

(Mr. Schaffer.)—Twenty-one miles southeast of Modesto. The sliding doors on a barn fronting east moved north and south repeatedly during the shock. A water trough a few feet away spilt water east and west.

(Johnson and Ross Store.)—A pile of paint cans stood northwest-southeast. Several cans fell to the northeast.

(G. W. Elsey.)—A tall, open-framed "Mission" clock facing southeast was found after the shock with its pendulum lodged on the top of a cross-bar of the frame. The position of the pendulum indicated a considerable increase in the amplitude of its vibration north-east-southwest in order to allow it to swing high enough to lodge. There were several



similar cases of lodged pendulums in clocks facing in the same direction. Mr. E. Elsey also noted a water-tank spilt east and west, and trees swayed in the same direction. He heard a rumbling sound.

(H. Hintze.)—A water-tank spilt east and west. A hanging lamp swung in the same direction, dropping its chimney to the east. A bed on the porch rolled east and west. He heard a rumbling sound during the shock.

(Editor of the Daily Herald.)—Bed moved northwest-southeast.

(Farmers' and Merchants' Bank.)—The vault is built upon a foundation independent of the rest of the building. The front of the vault, facing southwest, is continuous with a lath and plaster partition which extends to the ceiling. On the left is a wash-room, and on the right an opening into the room at the side and back of the vault. The plaster partition is cracked where it joins the top of the vault and part way down the sides, probably indicating a greater amplitude of motion in the building than in the more solidly constructed vault.

(W. A. Harter.)—At Ceres, 6 miles south of Modesto, a tank spilt north-south.

(W. R. High.)—One mile north of Modesto, a tank spilt north and south during the early part of the shock, and east and west later. Trees swayed north-south.

(Empire Stables.)—Drop-lights swung and water in trough spilt northwest-southeast.

(A. L. Holtham.)—Milk pans on shelf supported by wires spilt milk west. The shock was preceded by a roaring sound,

(Modesto Gas Works.)—Water in the gasometer tanks spilt northwest-southeast. A chandelier in the building hung by a 0.375 inch gas-pipe 12 feet long; after the shock was over this chandelier was swinging northeast-southwest.

(J. T. McNcly.)—Station agent saw the railroad water-tank spill northwest-southeast.

(Editor of the News.)—A water-tank belonging to J. Urie, 2.5 miles southwest of Modesto, was overthrown to the west.

The following were the clock records at Modesto:

Orientation.	Number of Clocks.	Stopt.	Not Stopt.
Facing northeast . . .	4	3	1
Facing southeast . . .	12	9	3
Facing southwest . . .	7	5	2
Facing northwest . . .	7	4	3
Total . . . . .	30	21	9

*Ceres, Stanislaus County.*—The shock was felt, but is reported as not seven

*Oakdale, Stanislaus County* (F. G. Koid).—The shock seemed to be in a northeast and southwest direction. In the school-house, a 2-story brick building, timbers lying in a northeast and southwest direction were loosened from the concrete at the ends, but those extending normal to this were not affected. Clocks stopt.

(E. C. Crawford.)—A flag-pole 110 feet high swayed apparently north and south; 2 clocks stopt; water in a tub moved north and south; and a stand lamp seemed to tip slightly north and south until steadied; but no objects were overturned.

*Westley, Stanislaus County* (W. G. Carey).—The town is on adobe soil with gravel at a depth of 20 feet. Furniture and pianos were moved across floors from the walls toward the south, and quite a number of pieces of furniture were toppled over. No chimneys were damaged, but several large water-tanks were demolished. These demolished water-tanks thru the country seem to have been rotated about one-fifth (\*ount<T-t'lot'kwisi\ Cars on the track were moved at least a foot. At the railway depot, a 1,401\*-pound iron wheel was rolled back and forth for a distance of 9 feet northwest and southeast. There

were 2 maxima in the movement of the earth, and the second was the stronger. Some men sleeping on a scow on the river 2 miles east of Westley heard a rumbling sound before any shock was felt, and came out of the scow to see what it was. Then the shock came and the waters rolled and foamed.

**COAST RANGES EAST OF THE RIFT AND SOUTH OF MOUNT HAMILTON, AND THE WEST SIDE OF THE SAN JOAQUIN VALLEY FROM WESTLEY TO DUDLEY.**

In the coast ranges on the east side of the Rift, south of Mount Hamilton, and along the west side of the San Joaquin Valley, settlements are few and widely scattered, so that opportunities for obtaining data as to the distribution of intensity were correspondingly rare. This territory was examined by Mr. G. F. Zoffman, under the direction of Prof. J. C. Brainier, and the results of his observations and of others are embodied in the following report:

*Pacheco Pass Road.* — Starting from Hollister, the county seat of San Benito County, the writer went up the Pacheco Pass road over the Mount Hamilton range to Los Banos, in the San Joaquin Valley. There are but few brick or stone chimneys in this neighborhood, and inquiries were directed to the splashing of milk and the falling of dishes and other movable objects. At the entrance to the canyon thru which the road winds, several houses were visited. Only a few dishes had been broken and milk was thrown only from pans well filled. At Bell's Station no damage was done beyond the loss of milk. High bottles and dishes standing upon shelves were uninjured. The residents say that the vibrations were from east to west, and had a rocking motion. Before the shock a rumble was distinctly heard coming from the west.

At ranch-houses about 5 miles northwest of Bell's Station, and farther up in the mountains, the shock was of considerably less intensity.

*Mountain House.* — The shock was reported as having been very mild; no dishes were thrown from shelves, nor milk splashed from pans. The proprietor states that the earthquake began with a north and south movement which later changed to the east and west. The shock here should be rated at V.

Going down into the valley on the east side of the Pacheco Pass the intensity of the shock perceptibly increased. At a ranch house 7 miles from the pass, nearly all the milk was thrown from pans and all the water from tanks. In a well where the water was 7 feet from the surface, some was thrown out. As noted by one gentleman, water was thrown from a tank, first from north to south, changing later to east and west.

*San Luis Ranch.* — At the east end of the valley, on the San Luis Ranch, Mr. Mills stated that he distinctly felt the vibrations begin from north to south; there was then a lull of a few seconds and then followed a very noticeable east and west movement. The surface of the ground is said to have moved up and down like the waves of the ocean. Thruout this valley, which is made up of gravels deposited on firmer rocks beneath, the shock appears to have been nearly uniform.

*Los Banos.* — On emerging from mountainous districts into the deep alluvial plains of the San Joaquin Valley, the intensity of the shock increased, until at Los Banos it reached a maximum. A count of the chimneys showed 57 per cent (17 out of 30) fallen. All the brick chimneys were damaged, as shown by the accompanying photographs. (Plate 123B, C.) A peculiar feature of the effect upon these structures was that all the damage was on the northeast and southwest sides. Frame buildings were not damaged beyond the falling of plaster, or the throwing down of chimneys. According to the statements of the residents, and the data obtainable, the vibrations were north and south.

*Volta.* — Out of 7 chimneys 6 were thrown down by the shock. The plaster in frame houses was considerably damaged, but none of the buildings was thrown from its

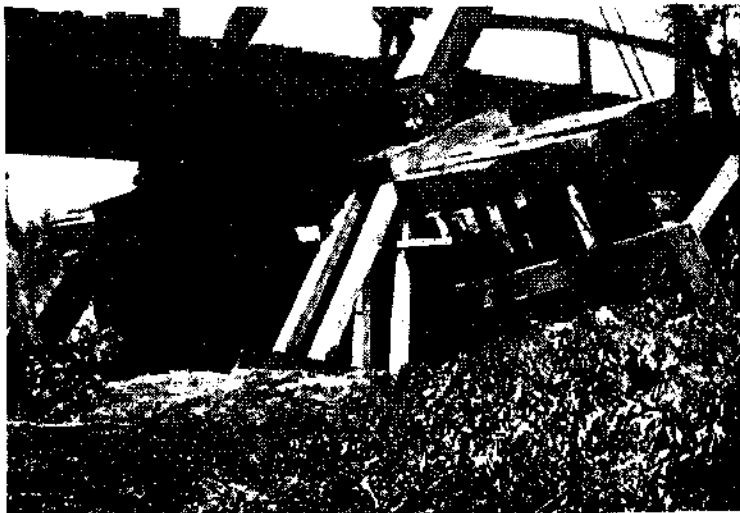

A. Bridge over Salinas Eiver, 4 miles south of Salinas. South terminal pier thrust south 7 feet.  
A. O. L.



B. Los Banos Hotel, W. L.



G. Los Banos Bank, W. L.



D. Oalinga. Z.

foundations. The town had no brick structures. The water of the nearby irrigation canals had, in places, been thrown up on the banks as much as 6 feet above the usual level.

*Newman.* — From Los Banos toward Newman the intensity of the shock appears to have decreased. At the latter place, out of 8 brick buildings only one, just constructed, was thrown down; one was cracked, while the remaining 6 were undamaged beyond the falling of a little plaster. Sixty per cent (36 out of 60) of all the brick chimneys fell, altho little other damage was done to frame houses. A man who saw the 53,000-gallon railroad water-tank fall stated that at the beginning of the shock it began to sway north and south, changing later to east and west, and finally falling toward the west.

*Crow's Landing.* — Out of 18 chimneys only 3, or 16-1 per cent, fell. Considerable water was thrown from the tanks. At a brick oil-pumping station about 4 miles north of Crow's Landing a few cracks were made in the walls. The large oil-tanks and water-tanks were undamaged. People in this neighborhood state that the direction of the vibrations was first from north to south, changing later to east and west. Opinions differ on this point. Many also state that a circular motion was perceptible.

*Grayson and Westley.* — The town of Grayson is on the banks of the San Joaquin River. No damage was done by the earthquake. A very few things were thrown from the shelves, but no chimneys were thrown down. At Westley all the chimneys were found intact. One poorly braced railroad water-tank fell, and one remained standing. The people in this district maintain that the direction of greatest intensity was north and south.

*From Westley to Mount Hamilton.* — From Westley the writer traveled up the Arroyo del Puerto over into San Antonio and Santa Isabel Valleys and up to Mount Hamilton. There are but few houses on the east side of the summit, and but little data was collected. The best was obtained at the Phcenix Quicksilver Mine. Here there are several brick buildings and chimneys, but no damage at all was done to them by the earthquake. In the tunnel there was no shifting of strata. At Mount Hamilton Observatory a couple of chimneys were cracked, but none fell. From Mount Hamilton, the writer went to Paicenes, in San Benito County, thru the Panoche Valley to Mendota, thence to Coalinga, Dudley, Cholame, and Peachtree.

*Paicenes.* — Going from Hollister toward Paicenes the intensity of the earthquake rapidly decreased. At the latter place, which is on the gravels deposited by Tres Pinos Creek, none of the chimneys (3 in number) were damaged, nor were the clocks stopt. Water and milk were thrown from their receptacles in an east and west direction.

*Elkhorn.* — At the Elkhorn roadhouse there were 3 clocks; the one facing north was undisturbed, while the other 2, one facing south and the other east, stopt. No water was thrown from the troughs nor milk from the pans. A few miles northwest of Elkhorn, the milk was thrown from pans on the northwest and southeast sides. The information obtained from the residents in regard to the direction of the vibrations was very contradictory.

*Emmet Post-office.* — At Emmet milk was thrown out in small quantities, but no movable objects were moved or upset. Near the summit between Tres Pinos Creek and the Panoche Valley, the shock was so slight that people did not think of arising. Nothing was thrown over, nor was milk splasht from pans. From Paicenes, where the intensity may be rated at about VI, it gradually decreased up Tres Pinos Creek until at its source the intensity was about IV.

*Panoche Valley.* — This region lies on the east side of the Coast Ranges. At the head of the valley the shock was so slight that some of the inhabitants were not awakened. On going farther down into the lower ground where the soil is deeper, the intensity was slightly greater. At the Panoche store water was thrown from the tank, but no dishes were broken. After leaving Panoche Valley, no definite information was obtainable before arriving at the Chainey Ranch 14 miles west of Mendota. This ranch is on the

plains on the west side of the San Joaquin Valley. The superintendent said that water was thrown out of troughs in a northeast and southwest direction. Movable objects were not disturbed.

*Mendota.* — Mendota is on the low alkali plains on the west side of the San Joaquin River in Fresno County. The intensity of the shock was comparatively light. In the town there were 17 brick chimneys and not one was thrown down. The railroad tank, two-thirds full of water at the time, was shaken down; but it was very insecurely built and only a very small vibration was necessary to overthrow it. Bottles and other unstable articles were not disturbed. The proprietor of one of the hotels, who was up, stated that the first movement was east and west, the second north and south, terminating with a decided twist. People who observed the plains at the time said that they assumed a wave-like appearance, and that trains rose and fell as the undulations past beneath the tracks. They also state that this wave motion was confined to the north and south movement, the east and west motion being more in the nature of a tremor. In the irrigated lands south of Mendota, considerable water was thrown from the canals.

*Mendota to Coalinga.* — At an oil-pumping station 10 miles south of Mendota, there were 10 large tanks; of these the roofs (unsubstantially braced) of 6 caved in, and much oil was thrown over the sides. The brickwork of the furnaces was not cracked. At the ranch-houses, about 6 miles east of the pumping plant, milk and water were thrown from their receptacles, and considerable damage was done by the breaking out of the head gates in the canals. The direction of greatest intensity is said to have been east and west. Many people in this region suffered from a nauseating sensation following the quake.

*Coalinga.* — The tops of a few of the walls of brick buildings were slightly damaged, as shown by the accompanying photograph. (Plate 123D.) A few dishes and bottles were thrown from the shelves, and water was slopt out of the tanks, but none capsized. The direction of greatest intensity of the vibrations was northeast-southwest. At the oil wells no damage was done either to wells or pipe lines. At a pumping station, the brick lining of the furnace was cracked slightly. Considerable oil was thrown from the tanks. In a large reservoir containing No. 10 oil (very heavy), the oil was thrown up 10 inches on the northeast and southwest sides. In a pump having No. 16 grade, the oil was splasht 3 feet up the sides.

*Dudley.* — Going south from Coalinga thru the Kettleman plains, the intensity of the shock apparently decreased, tho there were so few inhabitants that it was impossible to get definite data. At Dudley Station (a farm-house) nothing on the shelves was disturbed nor had milk or water slopt over. It was evident that the earthquake was less intense than at Coalinga. Entering the mountains west of Dudley, there was a further decrease in the intensity.

*Cholame.* — At the east side of the Cholame Valley, the occupants of a ranch-house had not felt the shock. At Cholame Post-office the shock was felt, but very slightly. The postmaster stated that it had a rocking sensation rather than a shaking one. At the Cholame ranch a mud chimney about 7 feet high was left standing out by itself, unharmed, but very insecure.

*Parkfield.*—Near Parkfield there are fissures in the earth, bearing N. 45° W., known to have existed since the first coming of white men. In some places the depressions are 35 feet deep. These fissures were not reopened at the time of the late earthquake.

*SUme Canyon Coal Mine.* — At the coal mine the shock was very noticeable. The fireman on duty the morning of the earthquake stated that the smoke-stacks, 35 feet high and guyed, swung considerably in various directions. No shifting occurred in the strata of the underground workings. It was stated that the movement was northeast and southwest.

*Peachtree.* — As Peachtree was approached, there was a perceptible rise in the intensity. About 2 miles east of the post-office, dishes had been thrown over and milk spilt from pans. At the station itself, however, nothing had been overturned. The region visited between Cholame and Peachtree is in small valleys lying in the mountains on the west side of the Salinas Valley. The soil is nowhere deep.

*Cantua Creek, Fresno County* (S. C. Lillis). — The shock was severely felt in this region, and its direction was southeast-northwest. A series of landslides caused by the earthquake were reported by Mr. Lillis, extending from the northwest corner of T. 18, R. 14 E., M.D.M. to the middle part of T. 15, R. 11 E., a distance of about 23 miles. The features were not at first recognized by Mr. Lillis as landslides, and as they occurred on the east side of the Coast Ranges, on the border of a portion of the San Joaquin Valley, where the intensity was abnormally high, the hypothesis was entertained that there might have been a supplementary fault in that region along the edge of the mountain range. The remarkable alinement of the features lent support to this suggestion. The region was, however, subsequently visited by Prof. G. D. Louderback, in company with Mr. Lillis, and the features reported by the latter were found to be landslides. Professor Louderback furnishes the following note regarding them:

The phenomena reported by Mr. Lillis are several landslides. In each case the effect of the movement can be followed in detail and sharply delimited. The form of the moved body is typically that of the landslide in each case, with the cliff at the upper end curved and concave toward the lower part of the slope. The mass has moved away and downward, leaving in some instances an open space or fissure, partially filled at the present time (May, 1907) by caving. The back cliffs, followed around, gradually pass into lateral planes of movement, which themselves are sometimes gaping on the more elevated side, showing a forward and slightly lateral movement of the mass. (See plate 125B.)

No general fissure, fault, or rift was observed passing thru or near these landslides, altho a careful search was made for such features. I suspected at first that there might be such a rift-line, because the landslides are approximately along one line or belt. This appears, however, to be due to the fact that one particular formation is especially favorable to landsliding, all the slides that I saw along the lower part of the range being associated with a thick reddish-brown shale of a definite stratigraphic horizon (Tejon?). The general structure of the range causes the rocks of any given horizon to outcrop along a line roughly parallel to the range front (approximately northwest-southeast). The landslides all look fresh, and according to Mr. Lillis several of them (and probably all of those under consideration) were caused on April 18, 1906. I made a trip across the hills from the valley to New Idria and noted nothing that appeared to be a recent seismic line.

#### EAST SIDE OF THE SAN JOAQUIN VALLEY SOUTH OF MODESTO AND THE ADJACENT PORTIONS OF THE SIERRA NEVADA.

In this region information regarding the intensity of the shock is rather scant. The shock was in general not sufficiently severe to excite alarm, and people as a rule did not note carefully its effects at the time. Such records as are available indicate that an intensity ranging from VI to V prevailed to the eastern edge of the valley, but that it died out rapidly in the mountains beyond.

*Merced, Merced County.* — Clocks generally were stopt, and hanging objects were caused to swing. One chandelier was observed to swing north and south, and then in a circle.

*Madera, Modern County* (F. E. Smith). — The principal disturbance was preceded by a tremulous motion for about 10 seconds. There were 2 maxima in the principal disturbance, the second being the stronger; and a tremulous movement succeeded it. The apparent direction of the movement was from southeast to northwest, and objects were overturned toward the northwest. The duration of the shock was thought to be 2

minutes. It was severe enough to rattle windows and move doors; to cause the bed to move; to swing hanging objects and stop clocks; and to overthrow ornaments, vases, etc., but not to throw chimneys. In other parts of Madera County the shock was reported from Daulton, Magnet, and Gold, but without sufficient details to afford a clear idea of the intensity of the shock.

*Fresno, Fresno County* (A. C. Obey).—No. VI of the Rossi-Forel scale describes conditions here quite accurately. There was a general awakening of sleepers, oscillation of chandeliers, stopping of clocks, and considerable agitation of trees. Some people ran out of their houses. Water in troughs was spilt out, etc. No damage was done to buildings.

(J. P. Bolton, observer of the U. S. Weather Bureau.)—At the time of the earthquake Mr. Bolton was on the third floor, standing near a window. The time of the shock was 5<sup>h</sup> 13<sup>m</sup> 30<sup>s</sup>. The first shock lasted about 10 seconds. It stopped clocks, swayed buildings, gasoliers, furniture, unlocked doors, window-weights and shutters. There was a short interval of cessation, then a second shock which lasted about 30 seconds, but was less severe than the first. It had a tremulous motion which gradually died away. Each shock developed its greatest intensity near its beginning. The apparent direction was from south to north. The intensity of the first shock was sufficient to sway the stoutest building and disturb its contents without displacing them, and to damage walls slightly. The only sound observed was that caused by the jarring of the building, etc. Many dogs barked vigorously shortly before the first shock.

*Reedley, Fresno County* (John Fairwether).—The shock was north and south; clocks stopped; some plaster was cracked, but no chimneys fell; a front door which was locked was caused to swing open. At Conejo water was sloped out of ditches to the north for 40 feet. At Jameson 2 distinct shocks were felt. At Riverdale, hanging objects were caused to swing. At Kingsbury, a slight shock was felt. At Fowler 3 wells were filled with sand. At Sanger a clock was stopped.

*Visalia, Tulare County* (F. A. Swanger).—A rocking-chair rocked vigorously northeast and southwest, but no shifting of the chair was observed as it rocked. The swell and fall of the earth-wave seemed strong.

(A. M. Doty.)—Four shocks were felt in Visalia, the last being the most pronounced. The town clock and almost all pendulum clocks in the city stopped. The vibration was from north to south. The Delta Building, a two-story brick structure, swayed to the south so perceptibly that it seemed difficult for it to regain its equilibrium. When it did sway back, the tin roof rattled as if some one were pounding on it with a hammer. Practically everybody in Visalia was aroused from sleep by the quake.

*Dinuba, Tidare County* (Miss L. H. Tindall).—There was a smart shock. A clock at the bank stopped. A crack in a brick building was so enlarged that the wall had to be strengthened by rods. A chandelier swayed from south of southwest to north of northeast. Elsewhere in Tulare County shocks were reported at Exter, Kaweah, Orosi, Porterville, and Tulare.

*Bakersfield, Kern County* (A. G. Grant).—The shock was strong enough to rattle windows and doors. Oil sloped out of tanks in the oil-fields 5 miles to the northeast of the city. Some clocks are reported to have stopped.

*Isabella, Kern County* (Stephen Barton).—Mr. E. King, lying in bed, noticed the swinging of a pistol scabbard suspended by a strap directly over his head.

## EAST OF THE SIERRA NEVADA.

DATA COLLECTED BY GEO. D. LOTJDERBACK.

*General note.*—In the towns along the east base of the Sierra Nevada and within, 25 or 30 miles of the base, the shock was distinctly felt, movable objects were seen to swing and heard to bump or rattle, and a very small number of persons were awakened. Farther east the most notable feature of the reports is that wherever the effects of the earthquake were made evident, the physical signs, such as the swinging of suspended objects, etc., were described almost to the exclusion of direct physiological effects. This is apparently at variance with the principles upon which the Rossi-Forel scale is founded, as the first 3 grades of intensity, beginning with the lowest, are based on feeling; the visible disturbance of objects not beginning until grade IV is reached. This may be due entirely or chiefly to the following conditions: Settlements are few and far between and many contain a very small number of inhabitants. When the earthquake occurred, the great majority were asleep, and the few who were up were moving about at active work and were in general not of a sensitive type. It is therefore probably impossible to get satisfactory and correct statistics indicating the distribution of the zones of intensity of the first 3 grades; and the sensible effects of the earthquake probably extended much farther east than reported.

Perhaps the most important of the physical signs reported is the disturbance of smooth water surfaces. In five instances, at three different localities, ditch tenders or irrigators noticed an agitation of quiet water surfaces and that the water lightly splashed against the sides as if from low waves, or as in a vessel of water when it is slightly tilted. As the morning was clear and entirely without wind, it impressed them as peculiar, and the matter was reported when they went to breakfast. The suggestion of one that something peculiar had happened, and of another that it was an earthquake, was each in its place the incitement of sallies of wit at the expense of the reporters. When news of the California earthquake reached these places several hours afterward, the time was found to agree as closely as determinable with the phenomena of the morning. In each of these cases, however, it was reported that no shock was felt. It is suggested that with moderately long waves such surfaces may prove very sensitive indicators of intensities down to the lowest degree on the scale.

The farthest point east at which earthquake effects were reported was Winnemucca, about 340 miles from the fault. A careful search was made for persons who had felt or seen indications of the shock. Only one apparently authentic case was found, and that was of a nurse who had retired a little after 5 o'clock, after a night's work at the County Hospital. She was lying quietly in bed and felt no disturbance whatever; but noticed a hanging lamp swing gently back and forth. Careful inquiry at newspaper offices, the telephone office, the post-office, and of the railroad agent, the weather bureau observer, and many individuals in different parts of the town, failed to discover another observation. This is rather remarkable, because Winnemucca is a town of considerably over 1,000 inhabitants. It is believed that the one definite report obtained is correct; and, as corroborative testimony, may be added the reports from two other localities almost as far east as Winnemucca, in which similar phenomena were described (in one the disturbance of a water surface, in the other a swinging lamp), with the further similarity that no shock was felt.

The elongation of the intensity zones in a northwest-southeast direction is marked. The strongest effects east of the Sierra Nevada were felt with practically the same intensity from at least Sierra Valley to Lone Pine (about 250 miles along the range), while 50 miles east of the Sierra the intensity had materially lessened, and 100 miles east



reports are practically unobtainable. This agrees, of course, with the elongation of the locus of disturbance.

It also appears probable that the sensible effects extended farther along Humboldt Valley, which is practically parallel to the direction of propagation, than along those lines where successive mountain ranges were thrown across the advancing waves, as in the southern Nevada region.

In most cases the direction of vibration was given as north-south, or northwest-southeast; tho in two or three cases north of west to south of east, or east-west, directions were given. Mo.4 of the clocks reported stopt faced north or south; a few faced west.

In a few cases the statement was made that there were two shocks very close together, but most of the observers did not distinguish more than one.

Details for the various localities follow:

*Round Hole*, 70 miles north of Reno (F. McMillan). — A distinct earthquake was felt which lasted several seconds.

*Peavine Mountain*. — A number of ranchers and miners were up at the time of the earthquake, on the north side of Peavine, about 10 or 12 miles northwest of Reno. No one noticed the shock nor any indications of it.

*Reno*. — The shock was distinctly felt by a number of persons. Some were awakened. The great majority knew nothing of it. A good account was given by Mr. Jensen, of the U. S. Weather Bureau. He was in the office to take instrumental readings. The office is on the fourth floor of a rectangular brick building, longer east-west than north-south. He heard some pictures rattle and thought the janitor was getting remarkably industrious downstairs; then he noticed that they were all rattling and surmised that it was an earthquake. His attention was attracted to an electric bulb on a long wire hanging from the ceiling, only a few inches from the west wall. It was swinging so as to hit a metal nipple on a pipe in the wall, thus making quite a noise. The building seemed to shake east-west.

*Olinghouse*. — Many were interviewed, but none had felt the shock. "While there are one or two vague reports, it is probable that no one really felt the effects at this place.

*Wadsworth*. — A canvass failed to elicit any definite account. The postmaster claimed he talked with many people, but knew of none who had observed the shock.

*Ilazen*. — Quite a number of people were interviewed, but no good definite account could be obtained. Most people decidedly had not felt it, and were not sure of any one who had. There were one or two hazy reports of persons who were supposed to have felt or observed it, and one man admitted having noticed a "light shock."

*Virginia City*. — Only a few persons noticed the shock. Mr. D. T. Smith was sleeping on the third floor of a rectangular building that stands east and west. He woke up and felt a movement of the building. An electric globe suspended by a cord from the ceiling (about 5 feet) swayed about 1.5 inches with an elliptical movement, the major axis a little north of west. No one else in the building noticed it.

*Wabuxka*. — A few are reported as feeling a "jar." No one noticed the direction.

*Yeringtm*. — A few felt the shock. It was light and described as north-south. One person in bed but awake said the bed rocked and a curtain swayed north-south, producing a sort of dizzy sensation.

*Fallon*. — Throe persons were found who claim to have been awakened; they were all women and light sleepers. One (Mrs. K W. Black) awokp and heard u noise which she thought was tho rattling of the window weights. Another (Mrs. I. H. Kent) awoke hearing a noise like tho rattling of a window. She also noticed a bird cage and a hanging plant swing in a north-south direction, the distance from tho point of suspension to the cooiter of gravity of those being about 5 feet. Others in tho same houses noticed nothing.

It is reported that ditch tenders on the Government irrigation canal noticed a disturbance of the water surface, and light splashing of the water as if by low waves or rocking. They reported it at camp in the morning some hours before news of the California earthquake arrived. Direct testimony is lacking on this point, tho the report was generally believed at the Reclamation Service Offices at Fallon and Hazen.

*Fairview.* — Reports from several sources are to the effect that no shock was felt, and no distinct evidence of the earthquake was observed.

*Lovelock.* — Several clocks are said to have stopt, but some of the reports, tho direct, seem to be unreliable. Several persons were awakened. One (Mr. Dawkins, principal of the Lovelock School) felt a slight shaking; others heard a noise as if a person were knocking, or the blinds or ventilators had rattled. One feared the powder house had "gone up." (F. J. Gunnell, A. G. Bosk, C. H. Valentine.) The clock in the hotel is said to have stopt. It hangs on an east-west wall and faces south. The station clock, in a similar position, was also reported stopt. On several ranches 8 to 12 miles south of Lovelock the irrigators noticed waves or splashing in ditches or canals, and reported the same at breakfast that morning. Ditches extend north-south; the slope is very low, almost horizontal, and the water surface smooth and quiet. (John Sullivan, irrigator for Lovelock Commercial Co.; Peter Naker, rancher; James Jensen, son of rancher, etc.) One report speaks of a lamp swinging. Those who saw the effects on water surfaces, and others in general, felt no shock.

*Mill City.* — The station agent said he had no positive indications of the earthquake and no one felt it.

*Unionville.* — Tom Powell, a rancher 4 miles south of Unionville, says that his wife woke him about daylight, and called his attention to the lamp swinging. They felt no shaking. They noticed later that a fine dust from the adobe walls had crumbled down on to the surface of the cream.

*Winnemucca.* — A rather thoro canvass of the town was made because it is the farthest east at which any report of the earthquake was made. Only one definite account was obtained, and it is believed to be reliable. Mrs. Sloane, nurse at the County Hospital, had been on night duty and had just retired. As she lay quietly in bed, she noticed a hanging lamp with pendant glass prisms swing. It swayed, in her judgment, nearly 3 inches, not far from east and west. She called her husband's attention to it and suggested that it might be due to an earthquake. It continued swinging some time. No shock was felt, nor was swaying of the building noticed. The railroad agent, the weather bureau observer, who was up at the time, the postmaster, the employe's in the telephone office, the people in both of the newspaper offices, and a number of other people in various parts of town, all said that they had felt no shock and had seen no effects of it, and knew of no one who had, except a few who had heard of the case of Mrs. Sloane. Another person, reported by one or two as having felt the shock, was interviewed, but claimed that she had felt no shock and that the report must have been started as a joke.

*Hawthorne.* — Two clocks are said to have stopt. Mrs. Taylor described the shock as a tremor, as if a pet dog were scratching and passing the bed, followed by a distinct movement toward the north and back toward the south. Mr. Brodigan, in the second story of the court-house, felt quite a shake.

*Mina.* — The shock was distinctly felt by some. In the store it was said that the building distinctly swayed, the dishes and tinware on the shelves making some slight rattling. In the telegraph office the clock stopt. The shock was very slight and felt by only a few,

*Bodlc* (E. B. Brooks).—The shock was perceptible; some clocks stopt. It was noticed by occupants in some 2-story building?, but was not generally felt.

*Mono Lake.* — A slight shock was felt on the west side of the lake.

*Candelaria* (Charles N. Platt, weather observer). — He did not feel the shock and knew nothing about it until the newspaper report came.

*Laws*. — Ten or more persons noticed the shock, which was slight. W. M. Richards stated that there were 2 shocks, one almost immediately after the other. The first was a gentle rocking motion, the second small jerks. The total duration was about half a minute.

*Tonopah*. — Several communications were to the effect that no one had noticed any indications of the earthquake.

*Goldfield*. — Several reports were received to the effect that no shock was noticed. A report was in circulation that the springs had changed somewhat in their flow, but the Superintendent of the Western Reclamation Company (F. A. Thompson), who keeps a very close watch of the wells and springs, says there was no change at all in the flow nor any other indication of an earthquake.

*Eureka* (Clay Simms).—A slight shock was felt, the movement being from west to east. It seemed to last for about a second. It made hanging objects swing, but did not stop clocks.

*Bishop* (W. A. Chalfant). — The shock was strong enough to waken many persons asleep. Large clocks in the jewelers' stores were stopt. The length of the vibration was unusual, but was not timed. The earthquake was not felt as a sharp shock, but rather as a long and not severe rolling motion. Doors, windows, window weights, etc., were shaken, and hanging objects, such as incandescent bulbs, swayed back and forth thru an arc of 12 to 18 inches, double amplitude. No damage whatever was done to property. Doors on the north and south sides of buildings seemed to have been affected most. In one instance a box of dry goods was moved about 3 inches. Out-of-doors the rumble of the shock was noted by a few persons.

*Independence* (Mrs. E. M. Brooks). —Some clocks were stopt and windows rattled, but few felt any shock.

*Lone Pine*. — A number of clocks were stopt, all facing north or south. The shock was noticed by only a few persons. According to one description, there were 2 shocks a few seconds apart. It seemed like a rolling movement, and a hanging lamp was noticed swinging north-south. Trees shook.

*Keeler*. — Only 2 or 3 persons noticed the shock. It was only slightly perceptible.

In gathering information concerning the California earthquake of the morning of April 18, as felt in the Western Nevada region, two other closely succeeding shocks were brought to light, one of which had much stronger local effects than the greater but more distinct earthquake.

*The Earthquake of April 19, 1906, about 2<sup>h</sup> 5<sup>m</sup> P. M. :*

This shock was mentioned by so few persons that I was at first inclined to consider it imaginary. It was reported, however, by reliable persons not known to each other in three different towns. The most definite accounts are as follows:

*Reno* (Miss Lowers). — Observer on the third floor of the Agricultural Building at the University, in the photographic laboratory; felt a very distinct shock, but did not remember the direction of movement.

*Olinghouse* (Miss Norris). —The person reporting and her sister were sitting in the house and felt a distinct shock. Fearing it was the forerunner of a larger earthquake, they ran outside.

*Hazen*. — A shock not generally felt was noted distinctly by Mrs. MacGregor, at the Reclamation Service headquarters.

*The Earthquake of April 19, 1906, 8<sup>h</sup> 15<sup>ra</sup> to 8<sup>h</sup> 30<sup>m</sup> P.M.* (Intensity, IV-V.) — This earthquake was distinctly felt along the east slope of the Virginia range and the valley land directly east and not far north or south of Lat. 39° 31'. Wherever reported it was

much stronger than the shake produced by the California earthquake of the previous day. It was generally felt at Hazen, Wadsworth, Olinghouse, and neighboring places where it is hard to find any one that noticed any effects of the great quake. In Hazen it rattled windows, made gas jets and lamps swing, and doors swing on hinges. The railroad station clock is said to have stopt. At Wadsworth, it made the windows rattle and caused some fear, owing to reports of the San Francisco disaster. One person describes it as a quick sharp shock like a blast. At Olinghouse also it was felt as a sharp shock — one called it a quiver — and caused windows to rattle. It was felt as far east as Brown's Station. It was apparently not felt at Fallon, tho it was distinctly felt 12 miles west at Carson Dam. In the Reclamation Service camp at Fernley it was quite strong, as felt on the ground in the tent. Judging from its areal distribution, it is suggested that this earthquake is related to the fault along the east base of the Virginia Range. The rough time estimates vary from 8 to 9 o'clock, but in cases where the time was noted more particularly, the variation is between 8<sup>h</sup> 15<sup>m</sup> and 8<sup>h</sup> 30<sup>m</sup>. The vibration was apparently northwest-southeast, or north-south, at Hazen. At Fernley (a short distance south of Wadsworth) it was described as northeast-southwest.

## OBSERVATIONS OF J. A. REID.

Professor J. A. Reid, who has been engaged for some time past in a geological study of the fault-zone of the eastern flank of the Sierra Nevada, made an examination of various faults with which he was familiar, with the view of ascertaining whether or not evidence could be found of movement at the time of the earthquake. No such evidence was, however, found. He also made an examination of several hot springs along the base of the mountains, to ascertain what changes, if any, had been caused by the shock. The only ones which seem to have been affected are the Steamboat Springs, 12 miles south of Reno.

In addition to making these examinations, Professor Reid obtained some valuable information regarding the intensity of the shock, as given in his notes which follow:

At Reno people were not generally awakened. There were no exact records of the time, direction, or intensity of the shock. The movement was large, but slow, and of long duration — probably about 40 seconds in total. The clock of ex-meteorological observer S. B. Doten stopt. An extension incandescent electric light, on an 8-foot cord, so arranged that it could swing only north-south, was set swinging thru a 3-foot arc. This was on the first floor of an old wooden house, and gives some indication of the magnitude of motion and time of oscillation. Mr. Doten was awakened by the shock and counted 20 seconds of lesser motion after he was fully conscious. No noise was heard. Another observer was awakened, and saw a 4-foot light and cord swing about 18 inches nearly east-northeast and west-southwest. At the University of Nevada similar lights were set swinging with a large east-west component of motion.

At Steamboat Springs the shock was felt as a long, gentle swing. A second shock, seemingly as hard as the first, was felt the second or third night after. At the Rocky Hill Mine, in the foot-hills of the Virginia Range, midway between Steamboat Springs and Washoe, the shock was not felt by men at work, and loose rock in the main tunnel was not dislodged.

At other points between Steamboat Springs and Carson, as at Lakeview, Washoe, and Lewer's Ranch, the earthquake was felt as a long, gentle swing. At Bowers Mansion, a few feet from the steep granite escarpment of the Sierra Nevada, all sleepers were awakened by the shock, which appeared to have greater intensity near the harder, more elastic rocks than in the loose valley deposits. The same result occurred in Carson Valley, south of Carson. At and near Genoa, directly at the base of the 4,000-foot scarp of the Sierra, the shock generally awoke sleepers, and trees were noticed to swing as in

a wind. A few miles eastward, however, in the river-laid valley deposits, the shock was felt by very few persons.

In the town of Gardnerville, some few miles east of Genoa, a number of people complained of a feeling of nausea while eating breakfast at the time of the earthquake, but felt no motion. In all cases the shock felt was characterized by long, gentle motion; in no cases was sharp movement experienced.

At Virginia City, about 6 miles east of the Rocky Hill mine, the shock was felt by very few people, and they were in the tops of the higher buildings. Around Dayton and nearby towns no reports came of persons feeling the earthquake. The Virginia Range seems not to have been greatly shaken. At Carson, the most reliable and abundant data were obtained. Mr. C. W. Friend, the well-known meteorological observer, obtained a seismograph record of the shock,<sup>1</sup> which was by far the heaviest ever recorded by him, the stylus of the instrument swinging entirely off the plate. Yet the motion was so gentle and of such a long period that sleepers were not generally awakened. The time of oscillation was not determined, but was described as being like the swinging of a hammock. The seismograph record is peculiar in that the stylus appears nearly to have retraced its course over one large curve. Carson lies about 3 miles east of the steep rise of the Sierra Nevada, with a deep deposit of river wash between. At the southwest, however, a low hill of schistose rocks just enters the town limits. This structure may play a considerable part in the peculiar motion of the earth here in this and other earthquakes.

At Paradise Valley, north of Winnemucca, the earthquake was felt by the few people awake or moving at that early hour. A rancher who happened to be near a small pond noticed an unusual agitation of the water, and supposed an earthquake to be the cause. The time was subsequently found to correspond with that of the shock, as reported elsewhere. No motion was felt, however.

## EXPERIMENTS WITH A SHAKING MACHINE.

BY F. J. ROGERS.

The investigation described below was undertaken with the hope of offering some explanation, based directly on experiment, of the greater destructiveness of earthquakes in regions where the foundations of structures are supported by more or less soft ground than where these foundations are based on solid rock.

As an earthquake consists in the actual shaking of the earth's crust it would seem, upon first thought, that the more rigid the foundation the more destructive would be the effects of the earthquake upon the structures so supported. This is in general not true, however.

In conversation with Dr. Branner, the great desirability of some experiments on this subject was suggested to the writer. In the first experiment which promised any interesting results a bucket of molding sand was poured out upon a board about 20 x 30 inches. The board was shaken in a horizontal direction through an amplitude of 2 or 3 centimeters, by means of a small motor. When the sand was moderately wet, the amplitude of vibration of the top of the mound was greater than the amplitude of vibration of the board on which the sand rested. This result is contrary to what I should have expected. When the result of this preliminary experiment was reported to Dr. Branner some time afterwards, he was greatly interested and urged the writer to carry on a series of similar experiments on a larger scale, the same to form a part of the report of the Earthquake Investigation Commission. As a result the apparatus described

---

<sup>1</sup> This seismogram is referred to in another part of the report.

below was designed and was later constructed by the Mechanical Engineering Department of Stanford University.

In designing a shaking apparatus to imitate an earthquake, certain conflicting conditions must be taken into consideration. It would seem that the apparatus ought to be on as large a scale as possible, but if it is on a large scale, it must needs be very expensive. If the linear dimensions are increased in any ratio, say trebled, the volume, weight, strength, and power to operate must be increased in the *cube* of this ratio; hence if the linear dimensions are trebled, these quantities must be increased 27-fold. Moreover, it is obviously impossible, at any cost, even to approach the scale on which nature acts. With these considerations in view it was decided that the scale of the apparatus should be as small as is consistent with obtaining results from which general conclusions might be drawn.

Earthquake motions are exceedingly complex, but it was not thought worth while to imitate this complexity, but rather to confine the shaking motion to a simple to-and-fro horizontal motion in one direction.

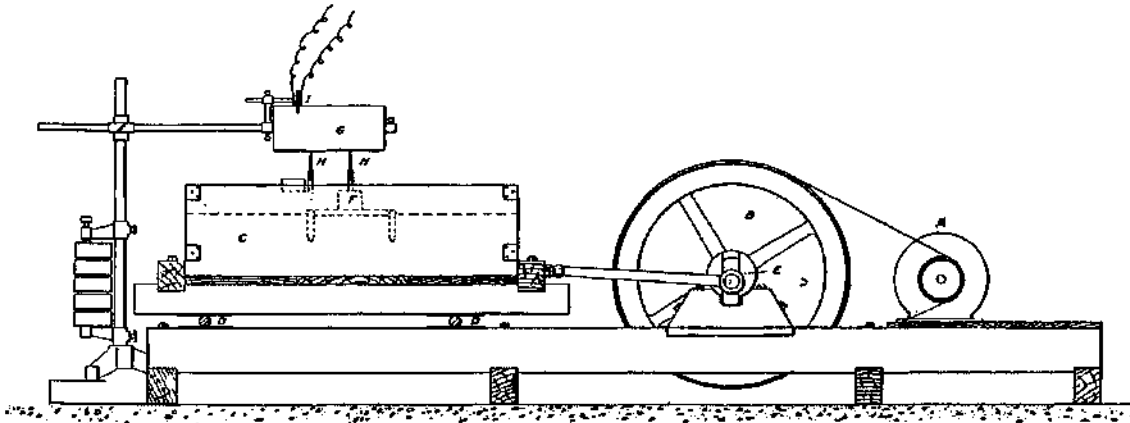

FIG. 60.—Diagram of construction of apparatus used in experiments

A side elevation of the apparatus as finally constructed is shown in fig. 60. *A* is a direct current motor, *B* is a balance wheel weighing about 75 kg. The connecting rod, instead of being driven by an eccentric, is driven by an adjustable crank, *E*, which allows the stroke to be adjusted to any value up to 10 cm. *C* is the car, whose internal dimensions are 100 x 86 x 30 cm. The car is carried on steel rollers, *D, D*, 4 cm. in diameter. The car, balance wheel, and motor were all mounted on a heavy framework securely bolted together. The drum *G* was mounted on an entirely independent support. A paper wrapt around the drum received traces representing, (1) the motion of the car, (2) the motion of a block *F* set in the material on the car, and (3) the beats of an electromagnet *I*, electrically connected to a seconds pendulum. (The pencil actuated by the electromagnet was on the same side of the drum as the other tracing pencils, instead of being on the opposite side, as shown in the figure.) The block *F* was 30 cm. square and was furnished with side pieces running 6 cm. down into the sand, so that its motion was necessarily the same as the material immediately under and surrounding it.

The experiment consisted in loading the car and then shaking it by means of the motor, with various amplitudes and frequencies. While the car was being shaken, the drum was rotated by hand, and the relative motion of the car and the block embedded in the load was determined by measuring the traces on the paper wrapt around the drum.

The material with which the car was loaded was limited almost exclusively to ordi-

nary building sand from a creek bed, combined with various amounts of water. Some experiments were made with gravel, but lack of time and the necessity of completing the work for publication in the report of the Earthquake Investigation Commission prevented more extensive experiments.

When the car was loaded with moderately dry sand containing 10 per cent of its weight of water or less, it was plain to direct observation that the sand was moving almost perfectly with the car, so long as the frequency was less than  $2\frac{1}{2}$  double vibrations per second. However, if the sand was wet locally by pouring water upon it, it was also very evident that the wet sand did not move at the same rate as the nearby dry sand. In the first place, the amplitude of vibration of the wet sand was greater than that of the dry sand; and in the second place, the reversal of motion was much quicker in the case of the former than of the latter. In the region between the wet and the dry sand, the difference in the relative motions of the two, causes the surface to be broken up by crevasses which open and close periodically. This breaking up of the surface is quite irregular, varying from moment to moment.

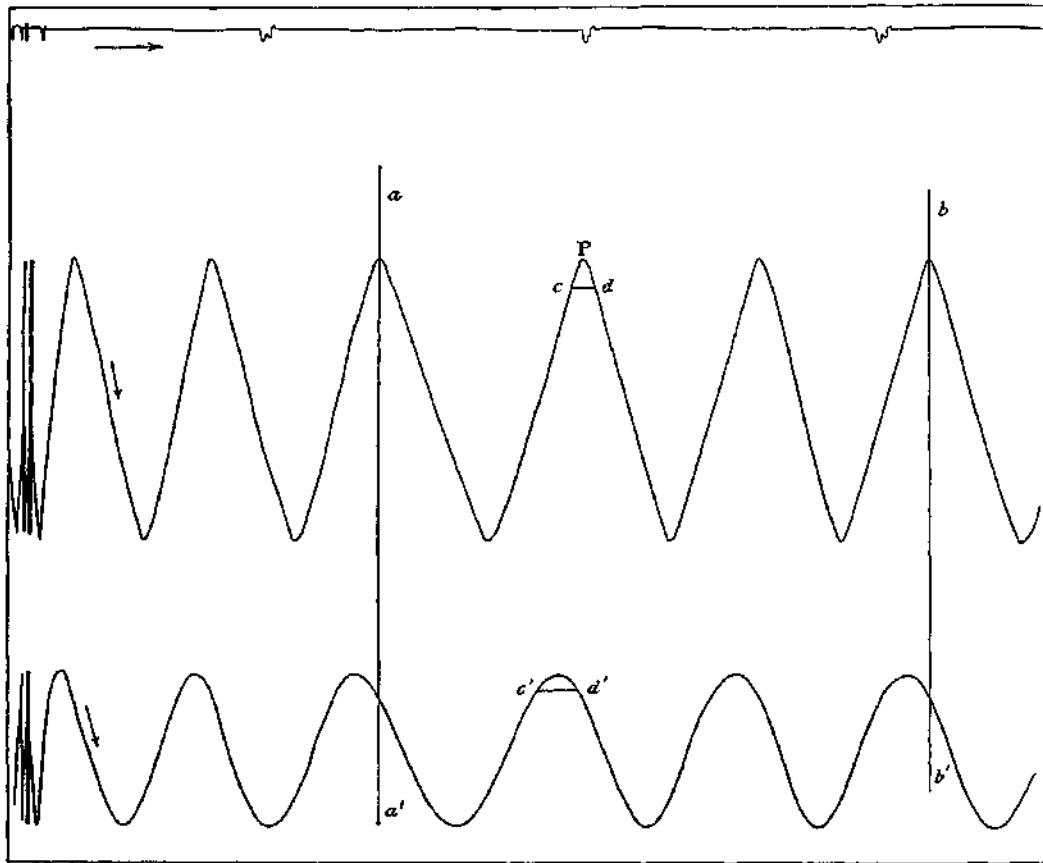

FIG. 61. —Curves obtained on recording drum. Reduced about half.

For a precise determination of the relative motion of the car and the sand with which it is loaded, it is necessary to measure the curves traced on the revolving drum described above. The method of doing this will be best illustrated by taking a particular case. Fig. 61 is a copy of one of the curves obtained on the drum. The lower sinuous curve is the trace made by the pencil attached to the car; the middle zigzag line is the trace made by the pencil attached to the block embedded in the sand; the upper line is the trace of the electromagnet beating seconds. In this particular case the sand contained

all the water that it would hold, so that it was very soft, almost semi-fluid. The amount of water was determined by weighing a portion of the wet sand and then weighing it again after it had been thoroly dried. In this case the material contained 20 per cent of water to 80 per cent of sand.

The traces show at a glance that the amplitude of the motion of the sand was much greater than that of the box. By reference to the transverse lines *aaf* and *W*, it is obvious that the motion of the sand lags behind the motion of the box—in this case about one-sixth of a complete period. Finally, the difference in the character of the two motions is shown by the sine curve in one case, and the zigzag line in the other case. The sine curve shows that the car has a simple harmonic or pendulum motion, as must necessarily be the case on account of the way in which it is shaken. On the contrary, the block embedded in the sand moves with an approximately uniform velocity until the end of the "stroke," when its motion is very quickly reversed; after which it again moves with uniform velocity until its motion is again quickly reversed. The acceleration at the instant the motion is reversed is a proper measure of the quickness of reversal. This acceleration can not be measured, but the average acceleration during a short interval of time while the motion is being reversed can be determined. If *cd* and *c?d'* (see fig. 6) are drawn at corresponding parts of the curves, then the lengths of these lines are proportional to the times required for corresponding changes in the two motions. The square of the ratio of these two times, divided into the ratio of the two amplitudes, gives the ratio of the two accelerations during the motion *cPd*. The closer *cd* is taken to *P* the greater this ratio becomes. In the present case, in which *cd* is drawn at one-tenth of the amplitude from *P*, the ratio of the two accelerations is about 3. As moving forces are always proportional to accelerations, the bearing of this result on the destructiveness of earthquakes is evident.

The data obtained from fig. 61 may be presented as follows: Load shaken, sand 80, water 20. Depth of sand, 22 centimeters. Frequency of motion, 1.7 double vibrations per second. Amplitude of car, 4.5 centimeters. Amplitude of block in sand 8.5 centimeters. Lag of block, one-sixth period. Ratio of accelerations at reversal, 3 or greater.

A large number of experiments were made with a load of wet sand having the above composition. Results similar to the above were obtained whenever the frequency of the motion was rather small. However, when the frequency of the motion was considerably increased, or when the ratio of water to sand was changed, the results obtained were quite different. In general the less water the sand contains the more nearly does it move with the car. The accompanying tables contain results from a large number of experiments in which the composition of the load and the frequency of motion was varied.

The data from these tables are plotted in figs. 62 and 63. In all cases the number of complete or double vibrations per second is plotted along the *rc*-axis, while the amplitude of motion of the block embedded in the sand is plotted along the *2*-axis. The points representing observations do not fall upon smooth curves, but this is hardly to be expected from the nature of the experiment.

The data as illustrated by the plots show that when the load consists of sand and water in the ratio 4 to 1, for low frequencies, the sand oscillates through a much greater amplitude than the car, and that the amplitude rapidly decreases as the frequency increases and becomes quite small for frequencies of 3 or 4 per second. On the contrary, when the load contains only 15 per cent of water, it moves with the car, for low frequencies, and the amplitude increases with the frequency. The results actually obtained are subject to a large probable error, but there can be no doubt about the decreasing amplitude with increasing frequency in one case and the opposite result in the other case. When the sand contains about 15 per cent of water, it seems to be more adhesive and more capable of packing into a relatively compact mass. In this respect it is distinguished



Results of experiments in which composition of load and frequency of motion was varied.

WATER: SAND = 20:80			WATER : SAND = 17:83			WATER : SAND = 15:85		
Frequency	Amplitude in Centimeters		Frequency	Amplitude in Centimeters		Frequency	Amplitude in Centimeters	
	Car	Block		Car	Block		Car	Block
.5	6.1	9.5	.6	6.0	7.9	.9	6.1	6.3
.75	6.1	9.7	1.0	6.0	8.5	1.7	6.2	7.4
1.0	6.1	9.5	1.4	6.0	9.0	2.6	6.4	8.1
1.3	6.1	9.2	1.6	6.1	9.3	3.3	6.5	8.4
1.5	6.1	7.3	2.3	6.1	9.5	3.6	6.3	8.0
2.0	6.2	5.9	2.4	6.1	7.5			
3.2	6.3	1.9	2.8	6.1	8.0	1.0	3.2	3.4
3.5	6.4	.3	3.6	6.4	4.4	1.2	3.3	3.8
			3.8	6.4	4.3	1.8	3.3	4.4
.83	4.0	7.4				2.7	3.4	4.7
1.0	4.3	7.2	.85	3.3	5.2	3.2	3.4	5.1
1.3	4.3	6.5	1.5	3.3	5.3	3.9	3.4	5.2
2.1	4.3	3.5	2.5	3.3	5.4	4.0	3.4	5.0
3.0	4.3	2.4	3.1	3.4	4.3	4.6	3.6	5.5
4.0	4.5	1.2	4.1	3.5	2.2			

WATER : SAND = :12:88.			WATER : SAND = 10:90   Two layers			DRT GRAVEL.			WET GRAVEL.		
Frequency	Amplitude in Centimeters		Fre-quency	Amplitude in Centimeters		Fre-quency	Amplitude in Centimeters		Fre-quency	Amplitude in Centimeters	
	Car	Block		Car	Block		Car	Block		Car	Block
1.8	6.2	6.3	1.4	4.4	4.5	2.5	4.6	4.6	1.9	4.6	4.6
2.5	6.4	6.4	2.0	4.7	6.3	2.8	4.6	4.9	2.7	4.8	4.9
2.8	6.2	6.4	2.3	4.7	6.4	3.2	4.7	5.2	3.2	4.8	5.3
3.2	6.7	7.0	2.5	4.7	6.5	3.3	4.8	5.4	3.4	4.7	5.8
			2.6	4.6	6.0	3.5	4.8	5.4	3.3	4.7	5.9
1.0	3.1	3.1	2.6	4.8	5.5	3.7	4.8	5.0	3.4	4.5	5.7
1.8	3.2	3.2	3.2	4.7	3.8	3.8	4.9	5.2	3.4	4.7	5.8
3.3	3.3	3.4	3.4		3.8	3.9	4.8	5.3			
3.8	3.4	3.7									
4.0	3.4	3.8									
4.2	3.5	3.8									

on the one hand from the soft and semi-fluid condition with a larger per cent of water, and on the other hand from a more friable condition with a smaller per cent of water. When the load contained only 12 per cent of water, the motion of the block embedded in the sand was very nearly the same as that of the car. For the data given, the motion of the block for the higher frequencies was slightly but unmistakably greater than the motion of the car. At another time, when there was about the same per cent of water in the sand, the motion of the sand was just as unmistakably less than that of the car, altho by only a small amount. In the latter case the sand was probably somewhat drier and less adhesive than in the former case. In still another experiment, in which the sand was very much drier, containing probably less than 5 per cent of water, the amplitude of the motion of the block was distinctly greater than that of the car, at least for frequencies of 3 per second. Of course this does not refer to the motion of the loose sand on top. The motion of a layer 1 or 2 cm. deep of such loose, dry material was always much less than the motion of the car.

In the above discussion we have been solely concerned with the motion of the block embedded in the sand in the middle of the car. The sand on the bottom and near the ends of the car has but little relative motion with respect to the car. A board thrust downward into the sand showed by its motion that the relative motion of the sand with

respect to the car increased from the bottom to the top. That the whole upper surface of sand in the car did not move together with the same speed was quite plain to direct observation. When the sand was very soft and wet, it rose and fell near the ends in the form of incipient waves, which, however, were not propagated away from the ends, three-

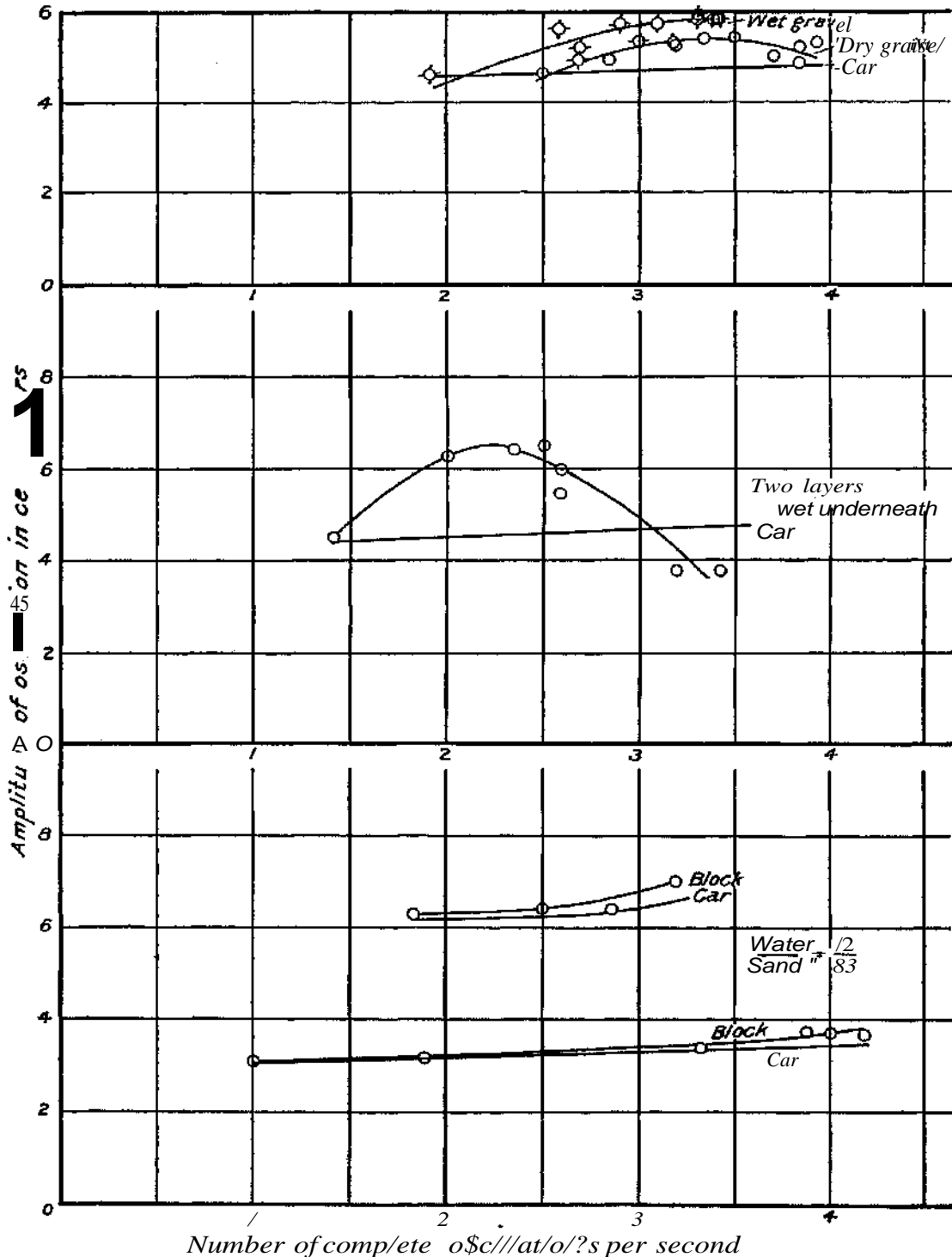

FIG. 62. — Graphic representation of result\*.

quarters of the surface remaining practically level during the vibration of the car. When the sand contained less water, the surface midway between the ends and the middle of the car was badly broken up by crevasses and ridges at right angles to the direction of motion.

It doubtless frequently happens in river valleys, coastal plains, or "made land" that a very soft water-soaked subsoil is covered with a crust of more solid ground. This condition of affairs was imitated on a small scale. A lower layer 13 cm. thick of very wet sand containing 20 per cent of water was covered by a piece of oilcloth, and upon this was placed a layer 12 cm. thick of much drier sand containing 10 per cent of water, and tamped into as compact a condition as possible. The block carrying the tracing pencil was embedded in this upper layer. If the whole load of sand had been like the top layer, it would have oscillated almost perfectly with the car. No such result was obtained with the two layers. When the car was shaken, it was apparent that there was still considerable freedom of motion in the lower layer. The upper layer moved as though it were floating on a semi-fluid mass. It rose and fell at the ends, and this motion extended to the middle, causing the block to rock back and forth, a result which was not obtained when the car contained a load of uniform consistency. The to-and-fro motion of the block was considerably greater than that of the car, for frequencies of 2 or 3 per second. For frequencies greater than 3, the amplitude of the block was less than that of the car. The results of this experiment are given in the tables on p. 330, while a plot of the same is included in fig. 62. The results, however, do not do justice to the possible destructiveness of such a motion. The rocking motion of the upper layer, as well as the violent manner in which it was broken up into fissures and ridges, seems to show that the destructive effect of the shaking motion of a semi-fluid mass may be increased when it is confined by a superincumbent layer of much more solid and compact material.

In the last experiment with the shaking machine, the car was loaded with coarse gravel. The gravel consisted of water-worn pebbles of all sizes up to 2 inches in diameter. It contained no clay nor sand to bind the gravel together. When this load of dry gravel was shaken, the block embedded in the gravel moved with the same amplitude as the car until the frequency reached 3 double vibrations per second. With higher frequencies the amplitude of the block was somewhat greater. Considerable water was then poured into the car, and it was again shaken with various frequencies. The results were similar to those obtained with the dry gravel, except that the relative motion of the gravel with respect to the car was nearly twice as great as in the case of the dry gravel. The data for these experiments are given in the table, while a plot of the same is given in fig. 62.

A consideration of the meager and more or less erratic data described above suggests various questions and criticisms. It has already been explained why more extensive experiments involving other materials were not undertaken. The erratic nature of the experimental data is not due to the method of experimentation employed, but to the uncertain and varying condition of the material with which the car was loaded. If, in the beginning of a series of experiments, the composition of the load was thoroly uniform, this was no proof that it remained so. A few moments of shaking sufficed to change to a greater or less extent this uniformity. When the material contained a large percentage of water, continued shaking caused the material close up to the ends of the car to pack and become somewhat drier; this was also true, tho to a much less extent, of the middle portion. The portion midway between the ends and the middle, where the relative motion of contiguous portions of the load was the greatest (thus causing fissures and ridges to develop), noticeably increased its content of water. This development of non-uniformity in the consistency and composition of the load is a sufficient explanation of the irregularity of the results obtained.

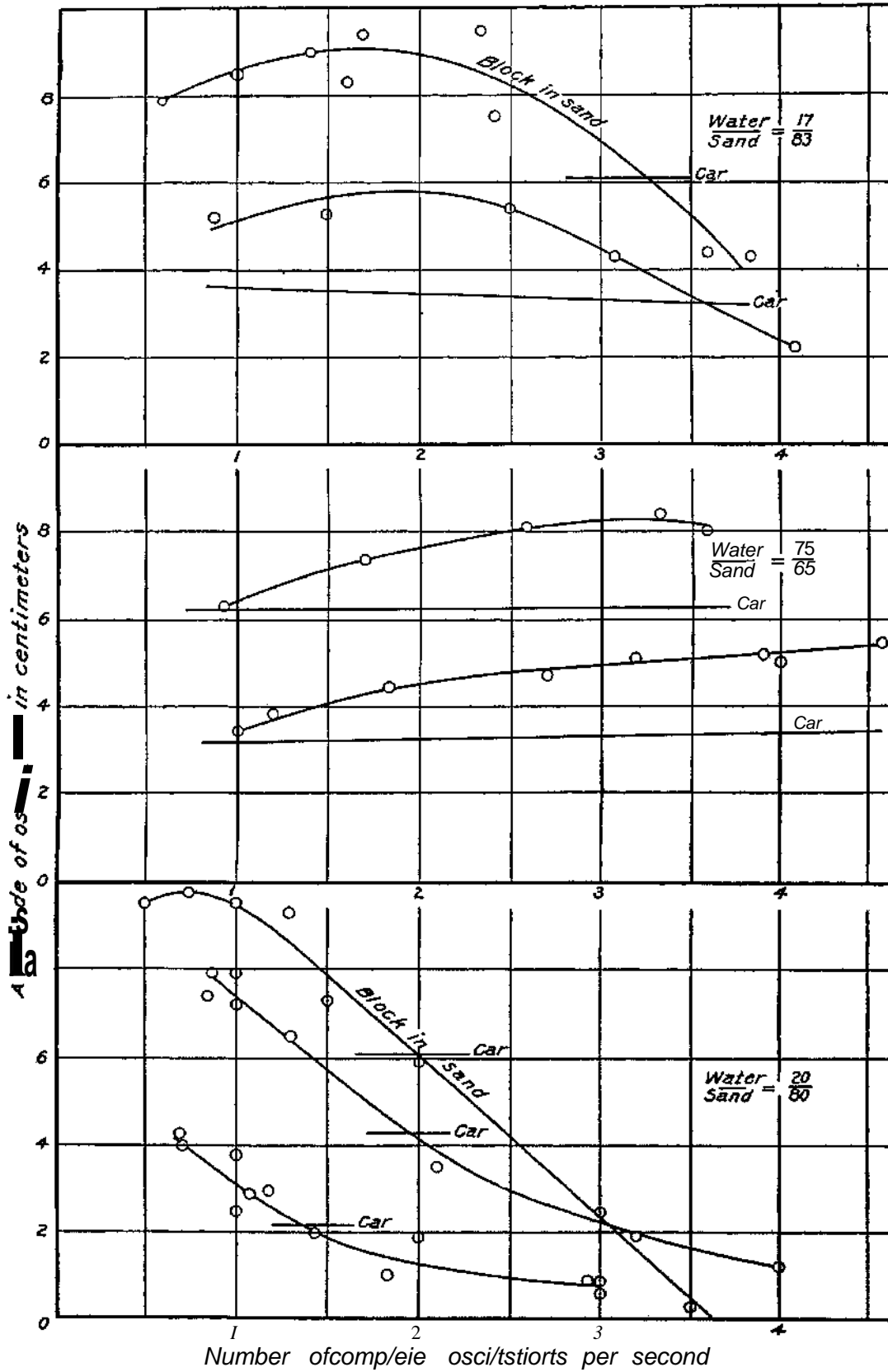

FIG. 63. — Graphic representation of results.

With regard to the scale on which the experiment was performed, the question naturally occurs: Would similar results have been obtained if the car were very much larger? One can not be certain, but it seems that such would have been the case if the frequency and amplitude of the car's motion were the same. Several experiments were performed with a depth of 15 cm. and 25 cm., and the results were substantially the same. The car was also divided by partitions running at right angles to the direction of motion, making a compartment of only half the length. The results tabulated below show that, at least in this case, the motion of the block embedded in the sand was not greatly affected by the presence of the partitions.

Length of car between partitions in cm.	101	49	101	101	49	49	101
Frequency in double vibrations per sec.	2.2	2.25	2.3	2.1	2.4	2.15	2.25
Amplitude of car in cm.	7.5	7.6	7.7	7.6	7.5	7.5	7.5
Amplitude of block in sand in cm.	11.9	9.3	11.3	10.8	10.8	11.4	11.8

In the experiment just described the material used contained 20 per cent water; with less water the partitions would doubtless have a greater effect in restricting the motion. It is also probable that with a larger car the relative motion of car and load would have been greater.

Another question which is likely to occur is: Does the solid or semi-fluid mass with which the car is loaded have a free period of its own which is comparable with the vibrations impressed upon it by the to-and-fro motion of the car? To elucidate this matter, the car was partially filled with water and the free period of gravitational waves determined experimentally. The frequency of such waves was found to be 1.06. However, the load, instead of being like water, was in all cases exceedingly viscous and plastic. This condition would in any case decrease the natural vibration frequency of the load, and in the present case the viscosity was so great that the load could not possibly have any vibration independently of the oscillatory motion of the car.

Finally the question may be asked: What is the explanation of the fact that the load on the car (or the major part of it) oscillates thru a greater amplitude than the car which causes the motion? At present I have no comprehensive explanation of this fact. It undoubtedly depends upon the inertia of the load, combined with the greater or less freedom with which it yields to impressed forces. The load in the car is set into motion by two sets of forces: (1) On account of the motion of the bottom of the car a tangential force is exerted on the bottom of the load and this is transmitted upwards by the rigidity of the load, or, expressed otherwise, by the mutual friction of successive layers of the load. (2) On account of the advancing motion of the end of the car the load receives a thrust which is transmitted thru the material by its resistance to compression. Sometimes one of these sets of forces is of greater importance, and sometimes the other. One would be apt to think the end thrust was of the greater importance, but this is certainly not always the case, for when the load consists of a *mound* not resting against either end of the car, the block embedded in the top of the mound may oscillate with a much greater amplitude than the car. (This was experimentally demonstrated.) In this case there can be no end thrust whatever. In some cases the end thrust may be more effective than the tangential force; this is probably the case when the frequency of motion is rather high.

To those interested in seismology the important question is: How do these experiments help to explain the greater destructiveness of earthquakes in regions where foundations are in alluvial soil than where foundations rest directly upon rocky strata? To pass from experiments upon a box containing half a ton of soil to the destructive effects of an earthquake is certainly a great leap. In taking such a step, one is very likely to make mistakes. However, it seems to me beyond question that a soft, semi-fluid mass of

soil, containing a large amount of water and surrounded or partially surrounded by solid strata, will not oscillate with the same motion as the surrounding strata. Moreover, in the case of the frequencies ordinarily occurring in earthquake motion, the amplitude of the oscillation of such a semi-fluid mass is likely to be greater than that of the surrounding solid strata; also the reversal of motion or the acceleration during reversal is likely to be greater than in the case of solid strata. Finally the greater relative motion of such a soft or semi-fluid mass is not prevented by overlying strata of drier and more compact material.

#### REVIEW OF THE DISTRIBUTION OF APPARENT INTENSITY.

In the preceding pages, all the data significant of the distribution of the intensity of the shock of April 18, 1906, have been set forth in such detail as seemed to be warranted in a statement of fact. The general conclusions drawn from the data are represented graphically upon the intensity map No. 23. It is proposed here, however, to call attention to some of the more interesting and instructive phases of the distribution of intensity, and briefly to discuss their significance.

It is to be noted, in the first place, that the region over which the disturbance was felt, extending from the Pacific Coast to Central Nevada, and from southern Oregon to southern California, is one of varied physiography. In a consideration of the relation of the physiographic features to the distribution of intensity, it will be necessary to distinguish only two classes of features; viz., (1) the mountain and hill slopes, generally underlain by firm rocks and veneered for the most part with a thin mantle of regolith and soil; arid (2) the valley-bottoms usually underlain by a relatively great depth of infilled alluvium in a little coherent condition, and for the most part saturated with ground-water.

The color bands on the map, indicating the gradation of intensity, show very considerable irregularities, or departures from the smooth curves which might reasonably be expected to obtain as the expression of such gradation of absorption of energy in homogeneous materials. To some extent such irregularities may be ascribed to the known lack of homogeneity in the firm elastic rocks of which the earth's crust is chiefly composed. But the irregularities referred to are too great to permit us to regard such lack of homogeneity in the underlying elastic rocks as an important factor in determining them. The irregularities are clearly related to the distribution of the valley lands.

#### GENERAL DISPOSITION OF THE ISOSEISMALS.

If now, before entering upon a consideration of these irregularities, we endeavor to ignore them, and so obtain a general conspectus of the color bands representing the gradation of intensity, the following features come out fairly clearly:

1. On the northeast side of the fault-trace, the zones of equal gradation of intensity show a tendency to belly out to the northeastward, opposite the middle portion of the fault-trace. This tendency is most pronounced in the grades from VII to II of the Rossi-Forel scale, and is apparent in all grades below IX.

The irregularities above referred to, associated with the distribution of valley lands, confuse<sup>1</sup> somewhat the perception of this tendency, but do not detract from its reality.

2. As a partial statement of the same general fact, the color zones become distinctly narrower, and their boundaries converge, as they approach the coast north of Eureka. This feature of the distribution of intensity clearly suggests that the isaseismal curves close in and swing around the end of the fault, and that there is, therefore, no indication of a submarine prolongation of the fault beyond its known extent on the mainland in Humboldt County.

3. The zones of equal gradation from IX to V of the scale are narrower at the southern end of the fault-trace than at the northern end, and they close around the end much more closely. This fact is suggestive of less depth of disturbance at the southern end of the fault. But the general disposition in the south of the zones ranging from V to II is not essentially dissimilar to those in the north.

4. The disposition of the isoseismal curves along the coastal territory between Point Arena and Shelter Cove indicates that the trace of the fault on the sea-floor lies but a few miles off shore, and that its course partakes of the nature of a very obtuse sigmoid curve, approximately parallel to the trend of the coast. It follows from this inference that the fault observed in Humboldt County is continuous with that extending from the vicinity of Point Arena southeastward. No facts have come to light which weaken this conclusion, altho all the facts have been diligently sought for.

5. On the southwest side of the fault, the territory upon which it has been possible to trace the isoseismals, particularly those ranging above VI, is very much smaller than on the northeast side. In so far as the territory available is representative of the entire southwestern crustal block, it appears, chiefly from the isoseismals covering portions of San Mateo, Santa Cruz, San Benito, and Monterey Counties, that the intensity diminished much more rapidly to the southwest than it did to the northeast. This interesting fact suggests that, of the two crustal blocks differentially displaced on the fault, the southwest block was perhaps the more passive. It may, however, indicate that the apparent intensity, as interpreted from effects on structures and objects, is a function of the character of the underlying rocks; since on the southwest side of the fault-trace there are extensive areas of highly elastic granitic rocks, while on the northeast side of the fault-trace these granitic rocks are deeply buried by sedimentary formations and appear nowhere at the surface west of the Sierra Nevada.

6. The zones of equal gradation of intensity, ranging from X to VII, are fairly evenly spaced, tho broadening with diminishing intensity; from VII to VI the zone is notably broader, particularly in the northern portion of the region affected; and from VI to II the broadening of the zones is very marked.

#### RELATION OF APPARENT INTENSITY TO VALLEYS.

The generalizations above set forth are independent of the irregularities in the isoseismal curves associated with the valleys. We may now inquire into the relationship which obtains between the valleys and the distribution of apparent intensity.

The most northerly locality where this relationship appears is on the flood plain of the Eel River, near the coast, in Humboldt County. The lower part of the Eel River Valley has been carved by stream erosion out of a synclinal trough of Pliocene strata having a thickness of over a mile. The syncline is flanked by older and much harder sandstones which are probably of Franciscan age. On the south of the valley these older sandstones constitute a bold mountain ridge, steep with terraces, which terminates in Cape Mendocino. The north side of the ridge has an east and west trend, and the Pliocene strata extend well up on its flanks. There is no suggestion of a fault on this side of the ridge, the trend being determined by the axis of the synclinal fold. The other side of the flood plain has a less regular northwest-southeast trend, converging upon the south side in the vicinity of Rio Dell. The flood plain is thus bounded by a wide trumpet-shaped but asymmetric contour terminating in lagoons and sand beaches south of Eureka. The depth of the alluvium of the flood plain is not known, but the features of the region suggest that it is undergoing subsidence and the alluvium may be several hundred feet thick. On this flood plain the apparent intensity was notably higher than on the surrounding slopes. This is shown by the extent of destruction in Fernald and other towns situated upon it, and by the rupturing and deformation of the

alluvium of the flood plain itself, particularly in its lower part near the sea, and by the lesser destruction in the surrounding higher country. The data regarding the intensity on the high ridge to the south are scant, owing to the fewness of habitations, but on the Pliocene terrane on the northeast side of the flood plain, there was a distinct drop in the degree of destruction, altho this terrane consists largely of strata which are only partially indurated and but little coherent.

The apparent intensity of the lower part of the Eel River flood plain grades from X to IX, tho in general nearer IX than X. It is surrounded by a belt of country where the intensity grades from IX to VIII. This belt has a width of a few miles on the Pliocene terrane to the northeast of the flood plain, and probably scarcely extends to the harder Franciscan rocks of the ridge to the south. The facts thus necessitate the recognition on the intensity map of an area of high intensity, including a range from X to VIII, in the midst of a region where the prevailing intensity ranges only from VIII to VII. This, as will be seen in what follows, is typical of all the more important alluviated valleys of the Coast Ranges, and indicates clearly that the apparent intensity for such situations is a function of the underlying formations.

On the more limited flood plain of the Mattole River at Petrolia, the destructive effects were even more intense than at Ferndale, and in marked contrast to those apparent in the few scattered houses on the rocky upland. But little can be inferred from this contrast, since Petrolia is situated on the projection of the fault-trace, and only a few miles beyond the most northerly point to which it has been mapped.

The town of Willets is at the headwaters of a branch of the Eel River on a flat alluviated valley-bottom several miles in extent. The situation and character of the valley are such as to suggest that it is a filled-in lake basin. The ground-water below the valley-floor stands within a few feet of the surface. The town is 26 miles from the coast at Mendocino City, and not less than 30 miles from the fault-trace; yet the apparent intensity was not less than IX of the scale, or equal to that which prevails on the hard rocks in the zone, the distal border of which is usually not more than 6 miles from the fault-trace and often much less. Between Willets and the coast the intensity had diminished from X in the vicinity of the fault-trace to less than VII. This rapid rise from less than VII in the territory immediately to the west, to IX on the valley-floor, with no evidence of other factors intervening, and no evidence of similarly high intensity on the rocky slopes surrounding the valley, again indicates that the apparent intensity is a function of the character of the valley-floor.

A similar condition prevails in the valley in which Tjkiah is situated, 20 miles to the south of Ukiah. The physiographic features of the valley are described by Mr. George McGowan in his report describing the effects of the earthquake at Ukiah. The town is about 27 miles from the fault-trace, and in this interval the intensity had diminished from X to less than VII. In Ukiah, which is on the old flood plain of the Russian River, near the middle of the valley-floor, the intensity rose to between IX and VIII. Here again, there can be little doubt as to the influence of the underlying formations upon the destructive effects of the shock. This conclusion is supported by the time at which the shock was felt. Ukiah is one of the few places where satisfactory time observations were obtained.

At the International Latitude Observatory, Dr. Townley reports that he was awakened by the shock and lookt at his watch, finding the time (corrected) to be 5<sup>h</sup> 12<sup>m</sup> 30", and he is of the opinion that the shock commenced at 5<sup>k</sup> 12" 17<sup>s</sup>. This accords fairly well with the time the shock was due at Ukiah, and affords no suggestion that the local high apparent intensity may have been due to a local earthquake.

Another valley area of high intensity is on the west side of Clear Lake, extending from Kcls'yville to Upper Lake. Lakeport, in the central portion of this area is 30



miles distant from the fault, with 2 mountain crests intervening. In this interval the intensity had diminished from X to less than VII, but at Lakeport and Upper Lake it rose to IX. The topographical and geological maps of the Clear Lake district, published by Becker/ show that Lakeport and Kelseyville are on an alluvial plain, the underlying deposits of which are of Quaternary age; and the same conditions prevail at Upper Lake. Between this area of alluvium and Bartlett Springs, on rocky ground, 10 miles to the east of Upper Lake, the intensity dropt to VI. At Lower Lake, situated on Tejon sandstone, the intensity had similarly dropt to VI; and these intensities are about the normal for the distances at which Bartlett Springs and Kelseyville lie from the fault along the coast. At Highland Springs, the intensity was between VII and VI, which is also about the normal for its distance from the fault. It thus appears that the high apparent intensity was confined to the alluvial or recent lake deposits of the area about Lakeport. These facts indicate that the high apparent intensity for this area was probably not due to a local earthquake, coincident or nearly so with the main shock, but that the destructive action of the latter was locally augmented by conditions inherent in the underlying incoherent deposits. For if there had been a local dislocation, its effects would undoubtedly have made themselves manifest over a wider area than that occupied by these deposits. The character of the shock, as described by those who experienced it in the vicinity of Clear Lake, agrees, moreover, with that of the shock emanating from the fault at the coast. Becker's geological map of the district shows no faults traversing it.

In general, then, while from the nature of the case it is not possible to deny positively that a local earthquake may have occurred on the morning of April 18, 1906, at the same time as the main shock, no evidence appears to sustain that view. On the other hand the evidence here as elsewhere supports the belief that the apparent intensity is a function of the underlying formations to the extent manifested in this district.

Coming now to Santa Rosa Valley, we encounter an interesting case of high intensity, associated with an alluvial valley-bottom. The valley may be described as an oval-shaped area, extending for 24 miles from Healdsburg to the vicinity of Perm's Grove, with a maximum width of 8 miles on a line lying between Santa Rosa and Sebastopol. The general trend of the central axis of the valley is about N. 30° W. It is thus not far from parallel with the general trend of the fault along the coast. Over a considerable expanse the valley-floor is perfectly even, and appears level to the eye. At its widest portion, however, it has a slope from an elevation of 170 feet above sea-level in the eastern part of the city of Santa Rosa, to about 50 feet above sea-level, a descent of 15 feet to the mile. In this section there are no terraces, but a perfectly even profile. To the north of Santa Rosa, however, the floor of the valley is less even, and it is stepped in a few broad terraces, the lowest of which is the present flood-plain of the Russian River.

The geomorphogeny of the valley is not altogether simple; the primary fact in its development, however, is that it has been carved by stream erosion to its full width out of a great syncline of Merced (late Pliocene) strata.<sup>2</sup> The upturned edges of these Merced strata, planed down to an even but now somewhat dissected surface, constitute the floor of the upper terrace lying to the north of Mark West Creek at an altitude of about 200 feet above the flood plain of the Russian River. On a somewhat lower terrace is the town of Windsor. South of Mark West Creek, the valley is in general deeply alluviated and the wells a little to the east of the city of Santa Rosa (150 feet deep) show that the alluvium is saturated with ground-water to within a short distance of the surface. The distribution of this ground-water thruout the valley is, however, not well known, no systematic investigation ever having been made. On the western side of the valley from Sebastopol

<sup>1</sup> U.S. Geological Survey, Monograph XIIF.

<sup>2</sup> Cf. Osmont, Bull. Ik-pt, Geol., Univ. Cal., vol. 4, No. 3.

northward to Mark West Creek, the drainage is stagnant and gives rise to the Laguna de Santa Rosa. This lagoon is a drowned water course in free connection with the trunk drainage of the Russian River, and is indicative of a deformation of the valley surface whereby the western side has been depressed below the base-level established by the Russian River. From these statements it will be apparent that the whole of the floor of the Santa Rosa Valley is not alluviated, but that portions of it — particularly that portion lying between Mark West Creek and Healdsburg and east of the flood plain of the Russian River — is a terraced platform carved out of the Merced terrane.

Now the notably high apparent intensity of the earthquake shock was confined to the alluviated portion of the valley-floor. The 2 centers of population which suffered most severely were Santa Rosa and Sebastopol. At Windsor, situated on the terrace cut in the Merced rocks, the intensity was distinctly lower. Healdsburg, at the northern extremity of the valley, is also on alluvium and the intensity was here again high, though not quite equal to that at Santa Rosa and Sebastopol. The town of Guerneville, on the old flood plain of the Russian River, below the Santa Rosa Valley, suffered most severely; while the cemetery of the town, but a short distance away, on a rocky terrace 190 feet above the town, was affected in a distinctly less degree, only one monument having been overthrown, and a few moved on their pedestals. The rapid diminution of intensity on passing from the alluvium to the rocky slopes, thus specifically illustrated at Guerneville, is characteristic of the borders of the Santa Rosa Valley. To the east of the city of Santa Rosa, this diminution is so rapid that the gradation of intensity can not be adequately expressed upon the intensity map. Under these circumstances it is difficult to avoid the conclusion that the severity of the earthquake shock on the alluvium of the Santa Rosa Valley is in large measure referable to the character of the ground. Were a local shock a factor in the case, we should expect that the high intensity would not be limited to the alluviated area, but would also be manifested on the surrounding mountain slopes. This expectation not being realized, the hypothesis of an independent local shock stands without support. The general position of the isoseismal curves off the valley-bottoms is not notably affected by the high apparent intensity in the valleys. In arriving at the conclusion that the high apparent intensity in this valley is referable in large measure to the character of the ground, it is not thereby intended to exclude other contributory factors. A theoretical discussion of the effect at the surface of the earth of a concussion at a point within the crust shows that for a certain path of emergence the horizontal jerk of the emerging earth-wave, and, therefore, the destructive effect in general, would be at a maximum. The fact that the earthquake under consideration was due not to a concussion at a point, but to a jar developed by movement on a plane at least 270 miles long, reaching to the surface and of unknown depth, renders the application of this doctrine difficult and of questionable value. Nevertheless, the tendency, which is demonstrable in the ideal case, would also exist in the more complex actuality; and it is by no means impossible that the zone of maximum destruction may fall in a general way within the Santa Rosa Valley, and would thus be a factor conducive to excessive destruction, in addition to the factor inherent in the character of the ground. This suggestion, to have weight, should be corroborated by observations in other portions of the general zone of destructive effects, and it must be confessed that satisfactory corroboration is lacking.

While the geology of the Santa Rosa Valley has not been mapped in detail, owing to the lack of topographic maps, it has been carefully studied, particularly from the structural and stratigraphic point of view, by Mr. Vance Osmond,<sup>1</sup> and no fault traversing the valley was found by him. The underlying structure, so far as has been made out, is as already stated that of a broad, rather simple, synclinal fold. It has also been indicated that the surface of the valley has been subjected to recent deformation, whereby the western side

---

\*.....

» *Hull. Dept. Geol., Univ. Cal., vol. 4, No. 3.*

has been depressed below the local base-level. This may be taken as an indication of the persistence of the compressive forces which originally gave rise to the syncline. If, now the underlying rocks of the valley were in a state of synclinal stress, the relief of that stress afforded by the dislocation along the line of the Rift might give rise to an elastic disturbance of the ground which would be additive to the shock generated at the fault along the Rift.

But none of these suggestions, whether of contributory shock, or an unrevealed fault, or of coincidence of the valley with a vaguely defined zone of maximum horizontal jerk, or of sudden relief from synclinal compression, are sustained by satisfactory evidence. They are possibilities which, with the facts before us, it is possible neither to affirm nor to deny. The reference to them in this place is only excusable on the ground that they are suggestive of lines of inquiry which may perhaps be profitably undertaken at some future time. On the other hand, the influence of the character of the ground upon the apparent intensity is sustained by cumulative evidence.

In Sonoma and Napa Valleys, the disposition of the isoseismals is very evidently determined by the contour of the valleys, the high intensities running far up the valleys within areas of lower intensity on either side. In Sonoma Valley the upper and lower parts are alluviated, while the middle part is not; or, if so, only to a slight extent, and it is being trenched by the stream which flows thru it. The floor of Napa Valley, on the other hand, is alluviated thruout, save for some rocky spurs and isolated rocky hills which occur along portions of the sides of the valley. The intensity diminishes in the upper part of Napa Valley, in the vicinity of Calistoga, where the alluvial deposits thin out, notwithstanding the fact that Calistoga is somewhat nearer the fault along the Rift than is Napa City, at the lower end of the valley, and notwithstanding the fact that Calistoga is approximately on the line of the Mount St. Helena fault described by Osmond. If the relatively high apparent intensity of Napa Valley were in any way referable to a local earthquake on a fault traversing the valley, we should not only expect the effects to be manifested on the rocky slopes of the valley, as well as upon its floor, but would also expect higher intensities on the line of the only well-defined fault known to traverse the valley. Neither of these expectations is realized, and upon the slopes of Mount St. Helena, in the vicinity of the fault which traverses its western front, the intensity was notably low—*not* higher than VI. We are thus again forced to fall back upon the character of the ground as the immediate cause of the high apparent intensity on the alluviated valley-floor, particularly in the lower part of the valley.

Specific and instructive instances of the influence of the character of the ground upon the apparent intensity of the shock are afforded by the cities of Petaluma and San Rafael. Each of these cities is built partly upon rock and partly upon the alluvium of the tidal marshes of the San Francisco Bay. Petaluma is situated at a distance of 14 miles from the fault, and San Rafael at a distance of 9 miles. In both cities the damage to buildings, chimneys, etc., was notably less upon the rock than upon the alluvium, altho the latter can not in either case be supposed to have any great thickness at the base of the hills. (See fig. 64.)

In the city of San Francisco the detailed study of the distribution of intensity, so successfully carried out by Mr. H. O. Wood, affords a conclusive proof of the paramount influence of the character of the ground in determining the high apparent intensities which affected portions of the city. On the made land in the vicinity of the Ferry Building, about 9.5 miles from the fault, as well as on the tidal marsh land, and along Mission Creek and Lagoon, between 7 and 9 miles from the fault, the intensity was X of the Rossi-Forrel scale. But on the rocky top of Telegraph Hill, near the ferries, the intensity was scarcely higher than VII. On the sandstone cliffs at Point Lobos, about 3 miles from the fault, it was about VIII; and on the summits of the chert hills in the cen-

tral part of the city and county of San Francisco, 5 to 6 miles from the fault, it was about VII. On the alluvium of Mission Valley, at distances of from 6 to 9 miles from the fault, the intensity varied from less than VII to between VIII and IX.

Under similar conditions of ground, the shock was greater nearer the fault; but there was much greater contrast between the damage produced by the shock on the summit of Telegraph Hill and that in the vicinity of the Ferry Building, at like distances from the fault, than there was between the damage near the ferries and that in the immediate

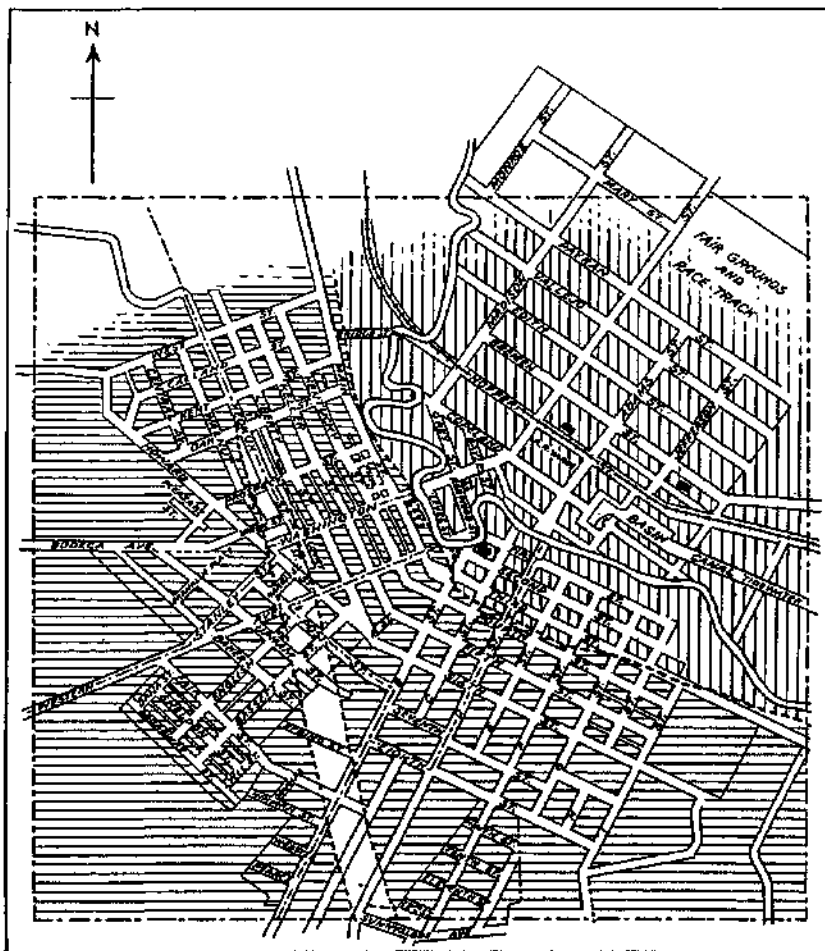

FIG. 04. — Distribution of intensity in Petaluraa. Vertical lines represent area of low-alluvial land, on which nearly all chimneys were damaged. Horizontal lines represent slopes underlain by rock, on which about half the chimneys were damaged. The solid black areas and dots represent exceptionally severe damage. The blank area inclosed by dotted lines represents a belt of practically no damage. By R. S. Hoiway.

vicinity of the fault. Thus, notwithstanding the general tendency of the intensity to diminish with increasing distance from the fault, it seems to be unquestionable that the degree of intensity which prevailed at any locality in the city depended chiefly on whether the underlying formations are firm rock or incoherent material more or less saturated with water. It would even seem possible to discriminate slight differences of apparent intensity on different kinds of firm rock for the same distance from the fault. Thus the chert hills appear to have suffered less disturbance than those where serpentine

outcrops; and the sandstone areas were more disturbed than the serpentine. But these differences are minute.

In the case of the made land and old marsh land of San Francisco, where the apparent intensity reached X, there can be no question as to possible local shocks, since the excessive disturbance was so strictly limited to the area lying outside of the original shore line and marsh border.

In the low ground about San Francisco Bay to the south of the city, we have another instance, on a rather large scale, of high apparent intensity determined by the incoherent water-saturated condition of the underlying formations. San Francisco Bay in general, and the southern portion of it in particular, lies in an alluviated valley which has been deprest so that its central portion is now below sea-level. This submerged valley-floor passes insensibly into the Santa Clara Valley which encloses it on the south and extends southward between the Santa Cruz and Mount Hamilton ranges. Treating San Francisco Bay and Santa Clara Valley as one physiographic feature, it may be stated, without going into the evidence in detail, that depression and alluviation have both been greater in the southern end than in the northern. This southern portion of the valley constitutes a great artesian basin, and many wells have been sunk in it. The deprest trough is not, however, wholly filled by alluvium, since several wells have past through late Quaternary strata containing marine fossil remains. It would appear, from the sections revealed by these wells, that with the progress of subsidence, marine deposition alternated with alluviation. The deposits, whether marine or alluvial, appear to be incoherent or unconsolidated, consisting of clays, sands, and gravels, in layers of irregular thickness and extent. Many wells have past through several hundred feet of such materials without reaching bedrock. One well, on the edge of the marsh near Alvarado, reached rock at a depth of 730 feet. At the sugar-mill at Alvarado, and at the Contra Costa pumping plant, in the same vicinity, there are several wells from 300 to 400 feet deep, passing thru clay, sand, and gravel without reaching bedrock. At Koberts' Landing there are 2 wells, one 574 feet deep and the other 540 feet deep, which past thru alternations of clay, sand, and gravel, but did not reach bedrock. A well 1.5 miles south of Milpitas past thru 11 layers of gravel aggregating 166 feet and 12 layers of clay aggregating 218 feet—total depth 384 feet—but did not reach bedrock. The wells in the vicinity of San Jose range in depth from 35 to 500 feet as a rule. One well on the bank of Guadalupe Creek, however, was sunk to a depth of 1,100 feet, but did not penetrate bedrock. A well at Stanford University is in gravel at 412 feet. On the west side of the Bay there are several hundred wells, most of them less than 100 feet in depth, while the deep ones are usually a little more than 300 feet. Wells are even bored in the bottom of the Bay and an abundant supply of fresh water is obtained from them. These brief statements will be sufficient to afford a general idea of the extent to which the valley has been deprest and filled in with deposits as yet unconsolidated. To the south, the rocky floor of the valley appears at the surface in the vicinity of Coyote, 12 miles south of San Jose. Beyond this, however, the valley again opens out and is deeply alluviated.

On the floor of this valley, from San Bruno Mountain southward, on both sides of the Bay, and southward a few miles beyond San Jose, the intensity was abnormally high. On the rocky slopes between the western edge of the valley-floor and the fault, the intensity had dropt from X at the fault to VIII at the base of the hills. On the valley-bottom it again sharply rose to IX. On this ground were Stanford University, Redwood City, San Mateo, the 44-inch pipe of the Spring Valley Water Company, San Jose, Agnews, Milpitas, and Alvarado. On the eastern side of the Bay the intensity of IX did not persist to the base of the hills, but extended only about halfway from the shore line to the edge of the valley. There was therefore a distinctly diminishing intensity in

approaching the base of the hills on this side of the valley. But at the base of these hills lies one of the dominant faults of the country — the fault upon which movement took place, with rupture of the ground, producing the earthquake of 1868. It would seem that, if local earthquakes were to be invoked to explain the high intensity of the alluviated valley-bottoms, here was a fine opportunity for an illustration of that doctrine. But the seat of the disturbance of 1868 was perfectly passive in 1906. The intensity diminished eastward right up to the fault-trace; and there is no suggestion that the disturbance along the San Andreas Rift affected it in the slightest degree. This being the case, there appears to be no recourse but to ascribe the normal apparent intensity about the southern part of San Francisco Bay to the character of the underlying formations as in other valleys before described.

To the west of the San Andreas fault in San Mateo and Santa Cruz Counties, the apparent intensity diminishes on the firm rocks more rapidly than to the east of the fault, but it rises very notably on the alluvial fan of Pilarcitos Creek at Half Moon Bay, and in the alluviated valleys of San Gregorio and Pescadero Creeks. Going westward down Pilarcitos Canyon, the apparent intensity drops from X at the fault to less than VII within 4 miles of the fault; but along the coastal fringes of alluvium which lie between the hills and the sea, it rises again to VIII at Spanish Town and to IX on the flats below the town. In the valleys of San Gregorio and Pescadero Creeks an apparent intensity of from VII to VIII extends for 4 miles and 3 miles, respectively, into an area of hill lands where the prevailing intensity is from VI to VII. The geology of this region, the Santa Cruz Quadrangle, has been mapped by Prof. J. C. Branner, and no fault is known at Half Moon Bay. Farther south the San Gregorio fault crosses the mouth of San Gregorio Valley and the middle part of Pescadero Valley, with a course parallel to the trend of the coast or transverse to the axes of the valleys. But the high apparent intensity in the bottoms of these valleys can not be referred to a local earthquake due to movement on this fault, since on either side of both valleys, in the immediate vicinity of the fault, it drops to below VII; while a few miles farther south on the same fault the apparent intensity drops to VI.

At Santa Cruz a portion of the city is built partly on a series of broad wave-cut terraces in the bituminous shale of the Monterey series and partly on the alluviated bottomlands of San Lorenzo River. The contrast in apparent intensity in these two portions of the city is marked. In that portion which is situated upon the terraces the apparent intensity ranges from VII to VIII, while on the bottomlands of the river it rises to from VIII to IX. It thus appears again, from a consideration of these four cases on the coast extending from Half Moon Bay to Santa Cruz, that the character of the material in the alluviated valley-bottoms has exercised a dominant influence in determining the apparent intensity of the earthquake shock, and that there is nothing in the facts to suggest that any other factor has played an important rôle.

The finest illustration of the influence exercised by alluvium in the production of high apparent intensity is that afforded by the valley of the Salinas River and its extension to the valley of the lower portion of the Pajaro River. The Salinas Valley is one of the notable physiographic features of the Coast Ranges. It lies between the Santa Lucia and Gavilan Ranges. It is deeply alluviated and strikingly terraced, particularly in its lower part. The course of the valley was probably determined originally by the fault along the eastern base of the Santa Lucia Range. The river discharges into the Bay of Monterey about its middle part, a few miles south of the mouth of the Pajaro River. On the flood-plain tracts of both rivers, and along the beach of the Bay of Monterey, the intensity was IX. This extended up the river for several miles above the town of Salinas. There were extensive fissures in the alluvium as far as Gonzales, with slumping of the ground toward the river trench. Damage of structures, indicating an intensity

of VIII, extended up the valley as far as Chualar; and the limit of intensity, VII, was reached only at King City, 45 miles above Salinas; VI in the vicinity of San Ardo, 65 miles; and V at Pass Robles, 99 miles above the same point. The isoseismals drawn thru these points are almost parallel to the river, the intensity to the east and west diminishing rapidly. The town of Salinas is about 13 miles distant from San Juan, in a direction normal to the fault-trace. On the northern end of the Gavilan Range, which intervenes between the two valleys, the apparent intensity dropt to V and then rose rapidly to IX in the Salinas Valley. The limitation of the high apparent intensity to the valley-floor, the practically symmetrical parallelism of the isoseismals to the median line of the valley, and the diminution of the intensity with the thinning of the alluvium and the constriction of the valley upstream, all indicate dependence of the character of the shock upon the constitution of the underlying formations, and suggest no other factor.

Still farther south in San Luis Obispo and Santa Barbara Counties, far beyond the isoseismal IV, an apparent intensity of IV is indicated by the effects observed in the valley-lands at San Luis Obispo, Edna, Arroyo Grande, Pismo, Santa Maria, Casmalia, and Lompoc. In the flat alluviated valley-bottom in which the town of Hollister is situated, about 8 miles east of the southern end of the fault at San Juan, the apparent intensity rose to IX, but diminished very rapidly on the hill lands immediately to the east of the valley to VI, which appears to have been the normal intensity for the mountainous tract between Hollister and the San Joaquin Valley.

Farther southeast there was a similar but less marked rise in the apparent intensity at Lonoak, Priest Valley, and Hernandez, all of these being on alluviated bottoms.

In the alluviated valleys to the east of the Berkeley Hills, the apparent intensity was abnormally high and the area occupied by these valleys constitutes an isolated area in which the intensity ranges from VII to VIII in the midst of a belt in which the range is from VI to VII. At Pleasanton the intensity was somewhat higher than at Sunol, altho the latter is nearer the fault of April 18, 1906, and is situated, moreover, on the line of an old fault which traverses the west side of Livermore Valley and extends up Calaveras Valley into the Mount Hamilton Range. At Livermore, in the more open part of the valley, where the alluvium is deeper, tho 8.5 miles farther from the seat of disturbance, the intensity was about the same as at Sunol. At Martinez, on an alluviated embayment of Suisun Bay, the damage clue to the shock was much greater than in neighboring towns situated on rock, even when the latter were nearer the fault. Beyond Martinez to the eastward there is a very marked bulge to the east of Suisun Bay, in the isoseismal VII, which can be attributed only to the low and marshy character of the ground. The apparent intensity at Antioch was a degree higher in the scale than that at Mount Hamilton, altho it is double the distance from the fault of April 18; and altho there are several old faults in the vicinity of Mount Hamilton and none are known near Antioch.

The influence of the valley-lands upon the apparent intensity is well shown on a large scale in the disposition of the isoseismal curves about the Sacramento Valley. In the mountains to the west of the Sacramento Valley the apparent intensity ranges in general from VI to V; but on the floor of the valley eastward to beyond the Sacramento River, it is very uniformly about VI or VI+.

The most interesting case of high apparent intensity in a valley-bottom remote from the San Andreas fault is that of the San Joaquin Valley. This case merits especial consideration, since of all the valleys here considered it is the one which is most suggestive of the occurrence of a local earthquake, distant from, tho connected with, the main movement on the San Andreas fault. While the suggestion is strong, however, the evidence is not conclusive of the occurrence in this region of a quasi-independent

earthquake; and all that can be done is to indicate the evidence which points that way, and cite certain facts which detract from the force of that evidence and tend to correlate the locally high intensity in the San Joaquin Valley with similar high apparent intensities in other valleys thus far discust.

The apparent intensity on the floor of the Sacramento Valley, as has been stated, ranges about VI + of the scale. This is somewhat higher than at several points in the adjacent Coast Ranges to the west, and the difference is ascribable to the alleviated character of the valley-floor and the water-saturated condition of the alluvium. As we follow the Sacramento Valley southward into the San Joaquin Valley, it converges upon the San Andreas Rift, and we should naturally expect an increase in the intensity by reason of the diminution of the distance from the seat of disturbance. This expectation is in a measure realized by an eastward bulge in the isoseismal VII opposite Suisun Bay, and by the somewhat higher intensity at Tracy and Westley than at Sacramento and Stockton.

Southward from Westley, however, the apparent intensity increases at a rate which can not be referred to the slight approximation of the region to the seat of the main disturbance. At Crow's Landing the apparent intensity is VII; at Newman it is VIII; at Volta it is VIII + ; and at Los Banos it is IX. These points lie on the west side of the valley between the San Joaquin River and the flanks of the Coast Ranges. South of Los Banos, on the valley floor, settlements are very few, and information as to the apparent intensity is unfortunately lacking over an extensive territory. At Coalinga, however, the apparent intensity is VII, indicating that the abnormally high figures prevail over the western side of the valley from Crow's Landing to southward of Coalinga, a distance in a north and south direction of not less than 100 miles. That the high apparent intensity was not wholly confined to the valley-floor, but also extended into the flanks of the Coast Ranges, is shown by the remarkable series of landslides which were started by the earthquake for a distance of about 23 miles northwestward from the vicinity of Cantua, reported by Mr. S. C. Lillis, and described by Prof. G. D. Louderback in another part of this report.

Now Los Banos, where the apparent intensity was highest, is distant 40 miles from the nearest point on the San Andreas fault at San Juan, its southern end. It is nearly 34 miles in an air-line from Hollister, the nearest point to the westward having a similarly high apparent intensity. In the Coast Ranges between Hollister and Los Banos, the intensity was as low as V.

These facts are suggestive, as already stated, of a local disturbance at or about the same time as the main movement along the San Andreas fault.

Certain circumstances detract, however, from the force of this suggestion, and indicate another possible explanation which, it must be confessed, is not very conclusive in view of the remoteness of Los Banos from the seat of disturbance. The portion of the San Joaquin Valley in which Los Banos lies is undoubtedly an underground water reservoir. It lies at the base of the alluvial fans of the Coast Ranges where the streams sink, and the waters of the San Joaquin River maintain the water-table at no great distance below the surface. As shown by the experiments of Prof. F. J. Rogers, described in another part of this report, water plays an important part under certain conditions in increasing the amplitude of the earth vibrations and, therefore, their destructive effect. In this respect the region about Los Banos would be particularly favorably conditioned for the development of high apparent intensities, as inferred from destructive effects. His general conditions are quite analogous to those in the Salinas Valley, in the bottom-lands of the Pajaro River and the Russian River, and in the region about the south end of San Francisco Bay. The chief difference is in the greater remoteness of the Los Banos region from the seat of disturbance, if only one such seat be assumed.



Another circumstance which weakens the suggestion of a local earthquake is the failure of the isoseismals below VII to carry out the suggestion by bulging into the Coast Ranges on the west or the flanks of the Sierra Nevada on the east. In the latitude of Los Banos, the high apparent intensity was confined to the valley-floor, altho farther south, near Cantua, this can not be affirmed. In view of the experiments of Professor Rogers, it seems probable that in the near future, by an active prosecution of such experiments coupled with close field observation, we shall arrive at an arithmetical expression for the coefficient which will enable us to reduce the apparent intensity of water-saturated alluvium to the true intensity due to vibration in homogeneous elastic rock. When that coefficient becomes available, it will perhaps be possible to determine whether or not the destructive effects exemplified in the San Joaquin Valley at Los Banos are referable to the conditions of the ground or to a local seismic disturbance. Until then the question must remain an open one. Analogy with other valley lands nearer the fault, where high apparent intensities are referable, both on the field evidence and in the light of Professor Rogers' experiments, to local conditions, militates against the hypothesis of a quasi-independent earthquake. The remoteness of the region from the known fault and the high intensities on the flanks of the Coast Ranges indicated by the new landslides at Cantua, favor that hypothesis; but no positive conclusion can be reached at present.

#### RELATION OF APPARENT INTENSITY TO KNOWN FAULTS.

Altho the geology of California has been studied in detail at but few localities outside of the gold belt of the Sierra Nevada, yet the general reconnaissance work that has been done by various geologists has brought to light many of the important faults in the state. Such as are known are indicated on map No. 1, without any attempt to discriminate between the varying degrees of certainty with which their existence has been determined. The map serves the double purpose of bringing together for the first time our knowledge of the distribution of faults thruout the state, and of illuminating a brief discussion of the relation of apparent intensity to fault-lines. On 4 of these faults there have occurred 5 severely destructive earthquakes within the last 50 years. It thus behooves students of Californian seismology to become familiar with these structural features of the state. A recent account of the Calabrian earthquake of September 8, 1905, dealing particularly with the distribution of intensity,<sup>1</sup> and the relation of that distribution to fault-lines known or inferred, gives an especial interest to the consideration of the faults of the Californian region at this time. In the preceding section of this report, it has been shown very definitely that abnormally high apparent intensities were developed on the valley-bottoms, and the cause of this has been referred in a general way to the incoherent and water-saturated condition of the materials underlying these valley-bottoms. In Calabria, in the account referred to, Professor Hobbs correlates the zones of exceptionally high intensity with lines of ancient faults, which in some portions of the region are known on geological evidence to exist, and in others are supposed to exist because of the high intensities manifested. He does not recognize the character of the underlying formations as an important factor in producing different degrees of intensity, as inferred from destructive effects at the surface. In this respect his conclusions do not harmonize with those arrived at in the study of the California earthquake of April 18, 1906. It thus becomes a matter of interest to ascertain what, if any, influence was exercised by the known faults of California, other than that which was the seat of disturbance, upon the distribution of apparent intensity, independently

---

<sup>1</sup> W. H. Hobbs, *The Geotectonic and CJeodynamic Aspects of Calabria and Northern Sicily*. Leipzig, 1907.

of that which was clearly due to the character of the geological formations. This question has been touched upon incidentally in the discussion of the relation of the valleys to distribution of apparent intensity, but it will be of advantage to review the facts here more systematically, tho quite briefly.

In southern Oregon and in northeastern California, in Modoc, Shasta, Lassen, and Plumas Counties, the shock was so uniformly feeble that there is no suggestion of locally high intensity due to any cause. The same general statement is true of northeastern California, in Del Norte, Siskiyou, Humboldt, and Trinity Counties; but in this region some of the faults, particularly that of Redwood Mountain, were not farther from the seat of disturbance than certain localities farther south, where abnormally high apparent intensity was developed on valley-bottoms. If the Redwood Mountain fault had been a locus of movement, there can be little doubt, altho the settlements in that region are few and scattered, that we should have heard of the severity of the shock. No evidence, however, has come to hand indicative of any exceptional severity on or near the line of that fault.

Along the eastern front of the Sierra Nevada, from Honey Lake and the Taylorsville district to Tejon Pass, altho there are many extensive faults, and altho on one of these there occurred a movement which caused the Inyo earthquake of 1872, yet there is no suggestion of any local movement on any of these on the morning of April 18, 1903. The intensity of the shock along this general fault-zone was about IV of the scale; but the movement was a slow, gentle swing characteristic of a heavy distant shock.

Similarly, the numerous faults which traverse California south of Tehachapi may be left out of consideration, no shock at all having been felt over the greater part of the region, and but feebly in those parts where it was felt.

There thus remain of the faults in California practically only those that fall within the zone of destruction, to merit serious consideration. The most northerly of these is the Mount St. Helena fault described by Osmont.<sup>1</sup> This fault has a northwest-southeast strike, and a throw of not less than 2,000 feet. It forms a well-marked and little-degraded scarp on the southwest side of the mountain and the date of its principal movement is within the Quaternary period. The projection of this fault to the northwest is not known; to the southeast it undoubtedly passes beneath the floor of Napa Valley, in the vicinity of Calistoga. Neither on the slopes of the mountain nor at Calistoga was there any evidence of abnormally high intensity, and the necessary inference is, therefore, that there was no movement on the fault at the time of the earthquake.

The southwest front of the Berkeley Hills, and the extension of the same geomorphic feature farther south, forming the southwest front of the higher Mount Hamilton Range, is with little question a fault-scarp, or series of scarps, of Quaternary date, now more or less dissected and degraded. The northern extension of the fault-zone beyond San Pablo Bay is not known. It probably contributed to the definition of the western side of the ridge between Sonoma and Petaluma, but apparently did not traverse the middle part of Santa Rosa Valley, since the study of that region by Osmont failed to reveal it.

This fault-zone is of peculiar interest from the point of view of the present discussion, since it appears to have been the seat of disturbance of the earthquake of 1868. At that time the fault-trace was marked by a crack at the surface, which was traceable for 20 miles or more along the base of the scarp slope, altho the amount of the movement was probably quite small. The trace of the fault is approximately parallel to the San Andreas Rift, and is 18 miles distant from it. As has already been suggested, this fault would seem *a priori* more susceptible to the influences which would make for renewed movement than most other faults of the region. But there is no evidence that any movement occurred upon it. The intensity showed no abnormal increase along

---

<sup>1</sup> *Lot. cit.*

the old fault-trace; and buildings at Berkeley, founded on rock, practically on the line of the fault, suffered little or no damage.

The fault which is so well exposed in the sea-cliff south of Fort Point traverses the city of San Francisco in a southeasterly direction for an unknown distance. Along the line of its probable course, Mr. Wood has noted evidence of an increase of intensity. The fault in its projection seaward probably intersects the San Andreas fault beneath the Gulf of the Farallones. It is therefore possible that there was some slight distribution of the movement along this intersecting fault.

The San Bruno fault-scarp, on the peninsula of San Francisco, south of the city, is well illustrated in Plate 15, and its structural relations are described in a paper by Andrew C. Lawson on the Geology of the San Francisco Peninsula.<sup>1</sup>

The base of the scarp is from 2.5 to 3 miles distant from the San Andreas Rift, and is nearly parallel to it. The fault is in two parts: a main fault with a throw of not less than 7,000 feet, which drops the Merced (Pliocene) strata against the older Franciscan rocks, and an auxiliary fault which drops a wedge of Franciscan strata between the main fault and the mass of San Bruno Mountain. The town of South San Francisco is on the lower slopes of a rocky spur of San Bruno Mountain, between the two faults, i.e., it is on the dropt wedge of Franciscan rocks. In the water-saturated alluvium and sands of Merced Valley, the apparent intensity was high, ranging up to IX of the scale; but in South San Francisco, on rock foundation, it was notably lower, as appears from Mr. Crandal's report. The situation of south San Francisco, between the two faults, is such that had a movement occurred on either, the damage to structures would have been accentuated. But the fact is that the damage was not so accentuated, and there is thus no warrant for supposing that any local fault movement occurred.

One circumstance which, upon first thought, seems to contravene this conclusion, was the sudden outgush of water at one point at the base of the San Bruno scarp. This remarkable occurrence is described in another place, but may be mentioned here, for the purpose of bringing together the facts bearing on the question. The water issued, as near as can be determined, at a point on the slope immediately above the fault-trace of the auxiliary fault, in the underlying hard rocks, which are there mantled with an unknown thickness of sand, possibly 50 feet or more. The outgush of water is indicative of sudden compression of incoherent water-saturated sand, and does not necessarily imply a movement on the deeper fault. Along the line of the fault there are longitudinal depressions, and it is suggested that one of these was filled with sand, under conditions which did not permit of rapid drainage; so that the sand was saturated with water, which was expelled as the compressive wave traversed the locality.

In the region to the southwest of the San Andreas Rift in San Mateo and Santa Cruz Counties there are several faults, most of which are represented on maps Nos. 21 and 22. No evidence of movement has been detected on any of them, altho the territory has been examined quite closely; nor does their presence appear in any way to have affected the disposition of the isoseismal curves. They nearly all traverse a country occupied by rocky mountainous slopes, and have considerable variation in orientation, altho the prevailing strike is northwesterly and southeasterly. One fault, however, viz., the San Gregorio fault, crosses 2 valleys — San Gregorio Valley and Pescadero Valley — in which the intensity of the shock was abnormally high. The independence of this high apparent intensity to the fault has been pointed out in another place.

To the north of Black Mountain, on the northeast side of the San Andreas Rift, a branch fault leaves the Rift line a little south of Portola, at an angle of about 25°, and is traceable for about 8 miles on the lower northeastern flank of Black Mountain. Between this Black Mountain fault and San Andreas Rift there is enclosed a wedge of

---

<sup>1</sup>U. S. Geological Survey, 15th Ann. Report.

ground in which the shock was of exceptional severity. It was traversed by numerous cracks, and there are other manifestations of acute disturbance of the ground, as set forth in the more detailed section of the report. In this case it is quite possible and even probable that the movement on the main fault in the line of the Rift was distributed to some slight extent along the branch fault. It is to be noted, in this connection, that to the south of Black Mountain there is a slight curvature in the course of the main fault to the eastward. This curvature would present an exceptional obstacle to the movement of the two crustal blocks, the one on the other, greatly increase friction, and so locally intensify the shock. It may thus be that the exceptional intensity in the Black Mountain mass, and the consequent bulging of the isoseismals on either side of the fault in this vicinity, is referable to this irregularity in the plane of the fault; and that the branch fault at Portola may be a means of relief from the excessive pressure locally induced by the irregularity. On the southwest side of the San Andreas Rift, and on the other side of the bulge in the fault-trace, is the Castle Rock fault, the strike of which branches from the main fault on the Rift at an angle of about  $20^\circ$ . Altho this fault has not been actually traced into the line of the Rift, there can be little doubt that it is a branch from that fault-zone and it probably bears the same structural relation to it that the Black Mountain fault does<sup>^</sup> *i.e.*, it serves as a means of relief for the exceptional local pressure due to the nearby irregularity in the main fault. There is, however, no observational evidence of any movement having occurred on the Castle Rock fault on April 18, altho it lies within the region of bulging isoseismals.

In the Mount Hamilton Range, between Niles Canyon and Mount Hamilton, there are many faults; but none of them, so far as the information available will warrant a conclusion, appears to have affected in any way the distribution of intensity. Two of these, the Mission Peak fault, which is probably a branch from that on which cracks opened in 1868 near Haywards, and Mission Creek fault, pass close to the town of Niles. But the apparent intensity at Niles was less than on the flat alluvial tract to the west, and not greater than in the valley-land about Pleasanton and Livermore to the east; and this circumstance amounts to a proof that no movement occurred on either of these faults. A similar conclusion may be drawn with reference to the Sunol fault, from the fact that the apparent intensity at Sunol was somewhat less than at Pleasanton, altho the former is nearer the Sunol fault than is the latter. In the country between the Haywards fault and the Sunol fault there are several minor faults, but there is no indication in the distribution of intensity of movement having occurred on any of them. Similar statements are true of the fault zone extending from the vicinity of Benicia northward on the west side of the Sacramento Valley.

In the canyon of Pajaro River, below Chittenden, there is an east-west fault whereby the Tertiary rocks on the north side have been dropt against the granitic rocks of the Gavilan Range on the south. This fault crosses the San Andreas Rift, and its known extent on either side of the Rift is within the zone of high intensity referable to the movement of April 18. There are here no especial features in the distribution of apparent intensity which suggest any movement on this fault. It is possible, however, that a slight movement took place on this fault, since the steel bridge over the Pajaro River, which is about on the intersection of the two faults, was distended 3.5 feet between its end piers, as shown in plate 65B, in a way that can not be altogether satisfactorily explained by the movement on the fault along the Rift. The direction of the chief displacement of the piers was about midway between the strikes of the two faults.

In the Santa Lucia Range to the southwest of the Salinas Valley, there are several faults. The principal one runs along the northeast flank of the range on the edge of the Salinas Valley. The reasons for ascribing the high apparent intensity on the floor of the Salinas Valley to the character of the underlying fontir\* ions, rather than to any

disturbance on this fault, have already been stated. Farther south, a fault runs parallel with the Salinas River in that portion of its course between Templeton and Dove; but here the apparent intensity was lower than in the valley lands both to the north and to the south.

To the southwest of this is another parallel, but a longer fault, along the southwest side of the San Rafael Mountains. In the valley lands to the southwest of this, about San Luis Obispo, Edna, Arroyo Grande, and Santa Maria, the intensity rose from III to IV; but in view of the accumulation of evidence set forth in the preceding pages as to the influence exercised by alluviated bottoms upon the apparent intensity, this rise is more probably referred to the character of the ground than to proximity to this fault-line. South of Santa Maria is a region of frequent seismic disturbance, but no sharp shock of a local earthquake was felt there on April 18.

It thus appears that in the territory extending from Humboldt County to Santa Barbara County, while there are about 40 faults known to geologists who have studied the region, there is no evidence of movement on any of them except in 3 cases. One of these is a branch from the fault-zone of the San Andreas Rift — the Black Mountain fault; another is a transverse fault intersecting the Rift in Pajaro Canyon; and the third is the fault which traverses the city of San Francisco and probably intersects the San Andreas fault beneath the Gulf of the Farallones. In these cases it is possible, in the light of the evidence, that some portion of the movement on the main fault was distributed along intersecting faults.

## DIRECTIONS OF VIBBATOBY MOVEMENT.

---

### GENERAL NOTE.

The data for the discussion of the directions of propagation and vibration of the earth-waves is for the most part unsatisfactory and leads only to a conviction of the complexity of the general problem of earth movement. Apart from the intrinsic complexity of the subject, there were two conditions which were adverse to the securing of exact and significant information. The first of these was the lack of provision for obtaining instrumental records of earthquake shocks thruout California. There were very few seismographs installed in the state and such as were in existence proved in large measure inadequate for the purpose for which they were intended. The second adverse condition was the hour at which the earthquake began. At its beginning most people were asleep, and the confusion incident to so rude an awakening was not conducive to sharp observation. The chief trouble, however, inheres in the intricate and confused nature of the earth movement itself. A brief statement of the different kinds of movement involved in the commotion of the earth may be of service in the formulation of clear ideas of the nature of the shock in general and of the question of direction in particular.

Usually the principal movement of the ground in an earthquake is vibratory. In the California earthquake there was, however, a mass movement in opposite directions on the two sides of the San Andreas fault. This mass movement was, as has been shown by the work of the Coast and Geodetic Survey, distributed over a wide zone on either side of the fault and diminished more or less regularly with distance from it. The movement was not vibratory except to a very limited extent; but it gave rise to the displacement of objects on the surface quite similar to that caused by the vibratory movement.

Thus, in attempting to deduce the directions of propagation and vibration of the earth-waves from the phenomena of displaced objects or persons, it is necessary to discriminate between the effects due to the mass movement and the true vibration of the ground. But this discrimination is only possible to a very limited extent, partly because the borders of the zone within which the mass movement caused the displacement of objects and persons are unknown, and partly because the two kinds of movement overlapt, conspiring to produce a single effect.

When we come to consider the earth-waves generated by the movement on the fault, probably as an effect of friction, it must be at once apparent that these waves emanated from innumerable points on a plane, one dimension of which is about 270 miles and the other probably 20 miles or more. On this plane, if we judge from the course of the fault-trace, there were at certain places inequalities which offered exceptional resistance to movement, and at these the jar was exceptionally heavy and dominated the vibrations emanating from portions of freer movement. From all parts of the fault-plane, therefore, waves of various amplitudes were propagated in all directions, and their paths intersected. The consequent interference would in part make for neutralization and in part for intensification of the vibratory movement. It is thus evident that the effects produced by the emergence of these waves at the surface, or by the propagation of those emanating from the more superficial portions of the fault along the surface, could be systematically disposed only if the following conditions obtained:

1. That the fault-plane were uniformly even or systematically uneven.
2. That the rock affected both by the rupture and by the vibrations were homogeneous throughout.
3. And that the stress which gave rise to the rupture were uniform for the entire extent of the fault.

It is fairly certain that none of these conditions actually did obtain; and we might, therefore, predict that the disposition of the effects of the shock, and particularly of the heavier portions of the shock, from which directions might be inferred, would be irregular, tho' the distribution of the intensity in the aggregate might be fairly symmetrical.

This conclusion has been reached on the tacit assumption that there is but one kind of earth-wave or vibratory movement. But it is highly probable on theoretical grounds, and the theory is supported by experiment, that the vibration of the earth generated at the fault resolves itself into two quite distinct waves having quite different rates of propagation and direction of vibration. One of these is the longitudinal wave, so called because the vibrations are parallel to the direction of propagation, and the other is the transverse wave in which the vibrations are normal to the direction of propagation. The rate of propagation of the longitudinal waves in highly elastic rocks is nearly double that of the transverse waves. It will thus be evident that at any locality within the zone of disturbance an object may be shaken or displaced by the emergence of the longitudinal wave at that point, and that the movement due to the emergence of the transverse wave may be superimposed upon this either before or after it has come to rest. The resultant effect will be accordingly difficult to interpret as to the direction of the vibration for either wave. When, however, the locality in question is sufficiently far removed from the fault, the interval between the emergence of the two waves may be sufficiently long to permit of the effect of the first being noted before that of the second is superimposed.

In the case of the California earthquake, the movement of the ground was complicated by the fact that both longitudinal and transverse waves were propagated in directions nearly parallel to the surface from the superficial portion of the fault, and these for many miles out from the fault might be expected to give rise to movements discordant with those due to the arrival of similar waves from the deeper portions of the fault. It would thus seem, from the considerations thus far presented, that regularity in the disposition of the effects of the shock upon which a judgment as to the direction of the vibration might be based, was about the last thing to be expected. In other words, it would seem, on *a priori* grounds, to be a hopeless task to plot upon a map of California the direction of propagation and vibration of the earth-waves. The hopelessness of the task is intensified when certain other considerations are taken into account. For example, there were secondary short surface-waves of low speed and high amplitude observed in many parts of California, which are quite different from the high-velocity waves thus far discussed. These undoubtedly had an important effect in the displacement of objects and persons, and so influenced judgments as to the direction of movement. Similarly on the alluvial bottoms of the rivers the ground lurched consistently toward the stream trench, whatever the orientation of the latter might be; and the phenomena arising from such movement gave rise to judgments as to the direction of the earth-waves which were of course erroneous.

Added to all this was the general fact that those who contributed reports from various parts of the state to the general account of the earthquake in many cases based their judgment as to the direction of the shock upon the displacement of portions of structures, such as chimneys, or of objects within buildings. This kind of evidence was in most cases untrustworthy, and could lead to reliable conclusions only when treated critically and statistically so as to obtain a general result. Even the displacement of buildings

themselves was no criterion of the direction of vibration of the ground except when these rested upon uniform foundations. Buildings upon poorly braced underpinning, such as are common in California, collapsed in consequence of the swaying; but the direction of the horizontal element in the collapse was more often determined by the nature of the structure than by the dominant movement of the ground. Even in cemeteries the direction of overthrow of simple shafts, circular or square in cross-section, failed to indicate the direction of the dominant movement, since within a small radius they fell to all points of the compass. The indication of the cemeteries was that the movement of the ground was very complex; the shafts were started swaying upon their pedestals, and the direction of their fall was for the most part accidental, as the rocking increased in violence due to the accumulating impulse. Treated statistically, however, the larger cemeteries afforded some indication as to the direction of the dominant movement of the ground.

In view of what has been said, it will not be surprising that the effort to interpret the reports from various parts of the state regarding the direction of movement of the ground has been unsuccessful. The reports were in general contradictory for the same locality whenever there were two or more independent observers. It was evident that most of the reports were based on evidence of the movement of the ground which had no significance in isolated instances, and a general critical review of the evidence was attempted only by a few observers. It was also evident that in many cases the effects of one movement had impressed one observer, while the effects of a different movement had attracted the attention of another. In these cases the contradiction was more apparent than real, but there was general doubt as to the correctness of both. Even when the reports were perfectly satisfactory records of facts, the latter in many cases permitted of no safe inference as to direction of movement except that there were several movements in several directions, and that the sequence of these could not be determined.

The following report from E. G. Still of Livermore is a good example of an excellent account of the important facts bearing on the question of directions:

The Railway Company's big 20,000-gallon water-tank fell to the north-northeast. Tombstones in one graveyard fell in many directions. Lamps swung in an oval, extending about east and west. The motion seemed to shake my bed north and south at first, then in a circular motion, then sideways and in every direction. Water spilt from full tanks, mostly on east and west sides.

There is a suggestion here of two dominant movements — a northerly and southerly, and an easterly and westerly, the former being the earlier. But Mr. Crandall, for the same territory, reports that the general direction of motion, based on the observed spilling of liquids and swaying of suspended objects, was northwest and southeast. In most cases the reports consist of a statement of opinion as to the direction of movement, without the facts upon which the opinion is based.



**EFFECTS OF THE EARTHQUAKE ON HOUSES IN SAN MATEO AND BURLINGAME.**

BY ROBERT ANDERSON.

Immediately following the earthquake of April 18, 1906, a detailed study was made by the writer\* of over 1,000 houses in San Mateo County. This work was carried on under the direction of Dr. J. C. Branner, of Stanford University. The houses examined included all those in the town of San Mateo and on the hills west of it in Burlingame and San Mateo Heights, as well as many in Homestead, Belmont, San Carlos, and Redwood City. Examination was made of all details that could possibly give a clue to the character of the earthquake shock, and its effects upon movable things.

San Mateo is a mile west of San Francisco Bay, and about 3 miles northeast of the San Andreas fault along which the earthquake had its origin. All the houses included in this investigation lie between 1 mile and 4 miles in a northeast direction away from the nearest points along the fault. A range of hills from 500 to 700 feet high lies between the fault and the valley bordering the bay where San Mateo and Redwood City are situated. The houses examined at Burlingame and San Mateo Heights stand on the northeast flank of this range of foot-hills. It was hoped that the directions of the streets of San Mateo, parallel and at right angles to the fault, would throw some light upon the relations of location to the center of disturbance.

## CRITERIA.

The following classes of evidence were examined, with especial regard to the direction and relative force of the shock:

1. The wreckage of brick, stone, and wooden buildings, the parting of walls, and displacement of parts.
2. The cracking of foundations and the movement of houses on them.
3. The cracking, crumbling, shifting, falling, jumping, and twisting of brick chimneys above and below roofs, as well as of cement, terra-cotta, and other chimneys.
4. The cracking and falling of plaster and coatings of cement on the interior and exterior of buildings.
5. The sliding, falling, and jumping of dishes, lamps, bric-à-brac, pictures, books, potted plants, and all such loose articles.
6. The sliding, tipping, jumping, and turning of furniture, such as bureaus, tables, bookcases, beds, pianos, stoves, safes, machinery, and all other large movable articles.
7. The falling, sliding, twisting, and jumping of tanks, towers, porches, pillars, underpinnings, gate-posts, mantelpieces, derricks, etc.
8. The breaking and offsetting of pipes, bending of bolts, shifting of stove-pipes, bulging of windows with lead seams, and the raising and lowering of sliding windows.
9. The shifting of loose piles of lumber, stove, and cord wood, and various materials, and the sliding of articles on rough and smooth surfaces.
10. The swinging of hanging articles, pictures, lamps, pendulums, etc.
11. The breaking of wire connections, such as telephone, telegraph, and light wires.
12. The remaining in position of articles at liberty to fall in certain limited directions.
13. The parting of ground at base of telegraph poles and cracking of ground elsewhere.
14. The spilling and splashing of liquids.
15. The feelings, experiences, and testimony of people.

This paper gives only the general results of all the data, the more important facts alone being tabulated.

---

<sup>1</sup> Valuable aid was received from P. C. Edwards, A. L. Motz, and A. F. Taggart, students of Stanford University.

DAMAGES.

*The effects upon brick and stone buildings.* — The region covered has only about 25 buildings of brick and stone. In most cases, the damage done to these structures was far more severe than to those of wood. "Usually a considerable part of some of the walls crumbled away, while the rest were left standing with large and small cracks in them. The tops of walls below the roofs usually suffered most, while lines of weakness in walls, caused by the presence of windows, arches, and other apertures, gave way to cracking more readily than other parts. A few brick buildings were totally demolished, as in the case of the long, brick, railroad warehouse at San Mateo. (See plate 98A.) The whole center of the picture to the right and left of the tower was occupied by the building, of which only the foundation remains.

Some brick buildings, stoutly constructed or wedged in on business blocks among structures that acted as common supports, withstood the earthquake well, altho some portion was almost invariably damaged. The triangular gable ends of brick buildings rarely remained in place. The cracking in brick structures seldom past thru the brick themselves, but usually took place along lines of cementing. The very few stone buildings in the vicinity of San Mateo were almost shaken to pieces.

*Wooden buildings.* — In general, wooden structures suffered much less severely than those of brick or stone, tho the shock was felt just as heavily in them and the damage to loose articles was just as great. The buildings least damaged were small wooden houses, which were practically proof against the earthquake.

*Foundations.* — The effect of the earthquake on foundations was of great importance, for the foundations were responsible for much of the damage to upper parts of buildings. With reference to this point, the buildings have been divided into 3 groups — those having foundations of wood, of concrete, or of brick. Wooden foundations are of various kinds, and the group includes all houses resting directly on the ground, or on wooden sills or wooden underpinning, even if the latter are supported on brick piers; it also includes all other buildings not having foundations of hard materials, such as concrete, brick, or stone.

The foundations were examined for evidences of movements in various directions, and for the purpose of learning the relative amounts of cracking to which each was subjected. The accompanying table gives the results:

Number of houses examined, with, number of houses moved, and number of foundations cracked.

Character of foundation	SAN MATEO.			REDWOOD.			BISL MONT, HOMESTEAD, AND SANCAKI'OS.			BUHXINGAMK AND SAN MATEO HILLS.			TOTAL.				
	Houses examined.	Houses moved.	Foundations cracked.	Houses examined.	Houses moved.	Foundations cracked.	Houses examined.	Houses moved.	Foundations cracked.	Houses examined.	Houses moved.	Foundations cracked.	Houses examined.	Houses moved.	Foundations cracked.	Houses moved.	Foundations cracked.
Wood . .	266	47	....	63	23	....	50	2	....	8	1	....	387	73	17	....	....
Concrete .	176	61	43	7	7	....	1	....	1	41	7	....	225	59	26	51	23
Brick . .	160	61	63	8	3	1	16	....	4	46	4	26	230	58	26	94	41
Total .	602	149	106	78	33	1	67	2	5	95	6	33	842	190	23	145	

The total number of houses falling into these groups is 842. Of these 23 per cent moved on their foundations. In most cases the movement was not so great as to necessitate the returning of the house to its original position, but this had often to be done, since many houses were rendered unstable. The distance moved varied from less than 0.25 inch to several inches, and in cases of special severity houses were thrown a foot or more off their underpinnings or foundations. Those on wooden foundations moved the least — 17 per cent in a total of 387 such houses. There were 225 houses on concrete

foundations and 230 on foundations of brick, and in each case 26 per cent moved. Out of the total of 455 concrete and brick foundations, 32 per cent were cracked, as follows: 23 per cent of the concrete foundations were cracked, while 41 per cent of the brick foundations were cracked. Nor does this proportion fully represent the facts, for it was only in rare cases that the cracking of the concrete was of much importance; while, on the other hand, the damage to the brick foundations was often sufficient to endanger the stability of the house. The wooden foundations were rarely damaged. In cases where houses had especially heavy foundations, the damage was noticeably slighter. Heavy concrete foundations rendered structures almost immune to the shock. Not many heavy concrete bridges, for instance, were harmed. In a store that rests on the massive concrete foundation of a bridge crossing the creek in San Mateo, absolutely nothing was disturbed, altho the building overhung the creek about 7 feet. None of the many loose articles on the shelves fell, and a high top-heavy machine stood perfectly.

The falling of brick chimneys suggests the possible influence of the foundations upon these structures. Of all the chimneys on houses having wood foundations, 91 per cent fell; of those on houses with concrete foundations, 81 per cent fell; of those on houses with brick foundations, 88 per cent fell. A truer relation is given by taking merely those on the flat land at San Mateo and Redwood City, where the cases are strictly comparable. Of these the proportions in the same order are 93 per cent, 98 per cent, and 96 per cent. The disadvantage of brick foundations is further attested by the greater damage to plaster in houses built on them.

*Brick chimneys.* — In the region studied, the tops of 88 per cent of all the brick chimneys fell at the time of the earthquake. This proportion is for the whole region. The varying proportions in the different localities are shown in the following table:

Table showing the number of brick chimney & examined, with per cent which fell, from houses on various foundations.

Character of foundations.	SAN MATEO.		REDWOOD CITY.		BELMONT, HOMESTEAD, AND CARLOS.		BURLINGAME AND SAN MATEO HILLS.		TOTAL.		
	Chimneys examined.	Chimneys fell.	Chimneys examined.	Chimneys fell.	Chimneys examined.	Chimneys fell.	Chimneys examined.	Chimneys fell.	Chimneys examined.	Chimneys fell.	Per cent of chimneys fell.
Wood . . .	280	257	64	63	51	44	15	11	410	375	91
Concrete . . .	187	165	9	8	3	3	85	55	284	231	81
Brick . . .	256	242	10	9	27	24	110	88	403	363	28
Total . . .	723	664	83	80	81	71	210	154	1097	969	88

Besides the falling of the tops, a large proportion of the chimneys that suffered this loss, as well as a great many that did not, were injured or cracked at the base or somewhere within the house. Economically, the damage below the roof is the most serious, as it is difficult to remedy and is a menace to the safety of the building. Some chimneys crumbled away entirely. This happened most frequently to those built on the outside of the house, in which case they usually fell away from the house, doing little harm. This may be considered a point in favor of exterior flues, inasmuch as the wreckage to houses due to the chimneys falling through the roofs, as well as the difficulty of repairing interior flues, is avoided. On the other hand, the unsupported exterior chimneys show a greater tendency to fall. Ash-boxes at the bases of chimneys weakened them at these parts, and made them more liable to injury. Only 12 per cent of the tops of the brick chimneys remained standing, the reasons for their standing being generally found in the construction of the chimneys themselves. The use of cement and lime instead of simply lime mortar, accounts for the standing of many, although the use of cement

did not always insure their safety. Many that stood were found not to be built up from the ground, but to rest on shelves somewhere within the house. This method of building seemed to preserve the chimney intact in the majority of cases. A few chimneys owe their preservation to their low, solid structure above the roof; many did not fall because they were well-braced, either by being inclosed in a wooden casing or a coating of cement, or by being held by iron rods clamped into the brick. A striking example of the advantage of an iron rod as support was that of a 2-story house in San Mateo. This house had a brick foundation and a slender chimney 14 feet high, supported by an iron rod. The chimney stood perfectly.

A great many chimneys that stood well above the roof were badly damaged at the base or within the house, and many were cracked above the roof and shifted a short distance horizontally. The use of cement in the mortar saved the chimneys in some instances, but a common effect of the shock on chimneys so built was to crack them somewhere and make them fall in one piece. In this way solid masses of great weight were sometimes pitched on to roofs and other parts of buildings, and the result was much greater damage to the house than was caused by chimneys built with lime mortar. Chimneys laid with lime mortar generally broke in many pieces or fell as loose bricks. The use of cement below the roof was apparently helpful, as the chief danger to that part of the chimney is from cracking rather than from falling, and the cement is much less apt to crack than the lime. The use of lime mortar above the roof is better, unless the chimney is to be boxed and braced. The construction of boxes around chimney tops, and the bracing with iron rods, are two simple and efficient preventives to the falling of chimneys of which comparatively few have made use.

*Chimneys other than brick.* — Many of the small houses of San Mateo County use terracotta thimbles or chimney pots, in place of brick chimneys. Their efficiency against earthquakes is conclusively shown by the fact that a large proportion of them stood unhurt, even when built in several sections. From 90 to 95 per cent of these chimneys past through the earthquake without harm. Galvanized-iron pipes, and stove pipes used as chimneys, were likewise unhurt in most cases. The few chimneys that were built entirely of concrete proved to be much stronger than those of brick.

*Plaster.* — In almost all houses with plastered walls, the plaster was cracked more or less seriously or broken off in sheets. The plaster or stucco on the outside of houses was badly damaged. In the majority of the houses, some of the walls — usually not all — were seamed with small cracks which ran in every direction and frequently in lines parallel with the laths. In other cases the cracks were wide and the walls were in large part laid bare.

The second table on page 305 gives the statistics regarding the cracking of the plaster. The first column includes the cases in which the plaster was almost unhurt or only slightly cracked. Most of these buildings did not require replastering. The second and third groups include the buildings more seriously damaged. Replastering was necessary in the second and third groups. The plaster on the ceilings of houses was much less affected than that on the side walls, and in the majority of cases was unhurt. In 2-story houses the plaster was rarely damaged as severely on the second floor as on the first floor, and in wooden houses of three stories it was often observed that the plaster on the third floor was uninjured. This restriction of the damage to the ground floor may be due to the breaking of the plaster by short, sharp movements near the ground, which were translated above into the swaying of the entire upper story. That the plaster did not crack much on ceilings was probably due to the fact that the ceilings (and the floors above) were not subjected to so much strain because they moved as one piece. Thick coatings and varieties of hard plaster seem to have been less damaged. New plaster not yet dry was not affected in the few cases observed.

*Dishes, etc.* — There were few houses in which something did not move or fall a noticeable distance, and yet few in which everything moved or fell. There was little regularity, even in the same house, in the amount of movement of loose objects. Innumerable instances of seemingly capricious variation could be cited. The earthquake resulted in severe damage to breakables and heavy loss of dishes and bric-à-brac. Approximate figures as to the amount of such damage are given in the table on page 365. In houses where only a few dishes fell the damage was considered slight. Those losing about half of the breakables are shown in the second column, and all of the more severe cases are placed in column 3. The percentages are at best only approximate. In the valley about 40 per cent of the houses lost slightly, and 40 per cent lost heavily, the loss in the remaining 20 per cent being intermediate. On the hills 74 per cent of the houses lost but little, and even in other cases the loss was not great. Many dishes were saved by raised borders on shelves on which they were standing. It often happened that loose articles fell from the lower shelves in pantries, etc., and remained on the topmost ones.

*Windows.* — It is an interesting fact that out of a total of thousands of windows in the area covered by this investigation, only a few were broken. Leaving out of account the windows of houses that were thrown down, the total number broken by the shaking or compression of the walls, or in other ways directly due to the shock, was probably not greater than 40. In several nurseries only a few panes were broken in many glass-covered hot-houses. The same general fact holds true over the whole of the San Francisco Peninsula, and in other regions affected by the earthquake that were visited by the writer. The majority of the windows that were broken were in brick buildings. That the windows were subjected to great stresses is shown by the fact that many of those made of parts joined by lead bulged considerably, and many were thrown upward with sufficient force to break their locks. In about 20 per cent of the cases where windows were raised in this way the glass was broken.

*A resistant type of structure.* — The data collected in this region appear to show that a house, to withstand an earthquake, should be constructed about as follows: The building should be of wood, and a wooden sill should be bolted to a deep-laid concrete foundation, the top of which should be but little above the level of the ground. It should be ceiled with wood within. Shelves for dishes should be closed in with doors, or should at least have strips along the front edges. The chimneys should be laid with cement mortar and boxed from a foot or two below the roof to the top, and the parts above the roof should be braced with iron rods. The lower the structure the less strain it will IM Fubjirtrl to. Such a building would be practically proof against earthquakes having an intensity below X of the Rossi-Forel scale.<sup>1</sup>

#### THE MANNER AND DIRECTION OF MOVEMENT.

*Kinds of movements.* — The shock of the earthquake was heavy enough to cause almost everything to move somewhat, and heavy objects were displaced as often as lighter ones. *Uwrv wæ* many cases of inconsistency in the movements, such as the displacement of *htivv* article like; pianos and stoves, where frail cups or vases remained in place; or *nivh* as the difference in motion exhibited by articles standing side by side. In many cases chimneys were thrown a distance of 6, 10, 15, and even 20 feet; a vase was thrown K feet, an acorn 4 feet, milk 8 feet. Hanging things were set in motion, liquid\* were spilt, and loose articles tipped over.

Ff^anl mavrim-nts in many different places were attested by the fact that sliding y/uflemi<sup>2</sup> were rAL-æci several inches with such force as to break the iron latches that to M ihvm down IWihy these windows were jerked up by their weights, which UoaA. m r. I!\* thrown down with force had the houses been subjected to sharp verti-

<sup>1</sup> *M. S. A. C. h.* reinforced *vuiu-n-is* structures are also of course eminently well adapted to resist earthquake shocks of high intensity. A. C. h.

cal movements. In Prince Poniatowski's house, which stands on the hills at an altitude of about 500 feet, a mile from the fault-line, all the windows — over 30 in number— were so raised. It is believed that all of the windows in this case were of the kind that are balanced by weights hanging within the frame. In many places on low land the same thing occurred. In one case a baby's cot jumped up and down, breaking its castors.

Bodies frequently assumed positions such as would have been imparted by twisting movements. This was true in the case of many houses, turrets, articles of furniture, hanging pictures, and chimneys. The apparent twists were both in the positive and the negative direction, and varied from a few degrees to 180 degrees. In the opinion of the writer, such positions were the result of a complication of movements rather than of a twisting motion. The twisted position of furniture was often ascribable to the rolling of the castors. Dishes, vases, etc., could easily change their orientation, especially if they were tipped up, as was frequently done. But the majority of articles were caused to shift their position horizontally, in one or more direct lines. A large number of houses slid on their foundations, dishes and books slid off their shelves, and but few things failed to change position.

*Movement of houses.* — One of the principal objects of this investigation was to find out in what direction houses moved on their foundations. Data were gathered concerning 842 wood, concrete, and brick foundations in regard to which it could be learned whether or not movement of the superstructure had taken place. Of this number 190, or 23 per cent, gave clear evidence of movement. In each case the direction and distance were tabulated. The directions are given in the following table. The distances are given in the first table on page 365.

Table showing direction of movements of houses on their foundations (total number of observations, 190).

Localities.	Group 1. Movements NW. and SW.				Group 2. Movements NE. and SE.				Group 1. Movements N. and S.		Movements in directions of Groups 1 and 2 combined.				
	NW.	W.	SW.	SW. and NW.	NE.	E.	SE.	NE. and SE.	S.	N.	NW. and NE.	W. and K.	SW. mid SE.	SW. and NE.	NW. and SE.
San Mateo . . . . .	25	23	40	18	8	*10"	10	2	4	4	....	2	3	5	5
Redwood . . . . .	6	8	1	....	1	....	5	....	1	2	....	....	....	....	....
Belmont, Homestead and San Carlos . . . . .	....	....	1	1	....	....	....	....	....	....	....	....	....	....	....
Burlingame and San Mateo Hills . . . . .	....	....	2	1	....	....	....	....	....	....	2	....	....	....	....
Totals . . . . .	31	31	44	19	9	10	15	2	5	6	2	2	3	5	5
Group totals . . . . .	125				36				8		17				
Group per cents . . . . .	G5				19				6		9				

Moved either SW. or NE., or in both directions, 31 per cent of total; moved either NW. or SE., or in both directions, 27 per cent of total.

The majority of houses that shifted moved southwest and northwest, or combinations of these directions. The west movements tabulated in practically every case were a combination of movement of the house over the edge of the foundation to the northwest and southwest equal distances, so that the effect was the same as from a single movement west. It was not known whether there had been a single shift west, or two at right angles southwest and northwest. The author inclines to the belief that there were two main movements causing houses to shift southwest and northwest, rather than one in an east and west line, inasmuch as so many of the movements were simply southwest or northwest, or not directly west. The movements tabulated in the southwest and northwest column are those cases in which both movements affected the house, one

predominating over the other. Grouping together all movements recorded as northwest and southwest and west, it is shown that 65.5 per cent of all the houses moving shifted in these directions. The second group of the table includes all movement in directions opposite to those of group 1 — that is northeast, east, and southeast. These make up 19 per cent more of the total. In the third group are included all those moving back and forth in the directions of groups 1 and 2, or partly in one main direction and partly opposite to the other main direction. These comprize 9 per cent. If, then, as the writer supposes, the west and east directions may be eliminated by being separated into their components, there will be 93.5 per cent of the total number that moved northwest, southwest, northeast, and southeast.

*Movement of chimneys.*—The great majority of chimneys in the region under discussion are of brick. They are of many different shapes and sizes, in different positions on the roofs, of various materials, and are affected by structural variations and by age. They could not be expected to show perfect consistency in the direction of fall, but statistics were gathered in order to find out the tendency of the majority and their value as indicators of direction and intensity.

In the following table the brick chimneys are grouped according to whether they fell in the direction of the slope of the roof on which they stood, obliquely, or at right angles to this; directly opposite to this, up the roof; or according to whether they jumped. Those not falling form another group, of which a few shifted horizontally. The majority of streets on which the houses enumerated in this paper are situated, run in northwest and southeast, and southwest and northeast directions, so that the slopes of roofs are generally in those directions. More slope northwest and southeast than southwest and northeast. These directions of roof-slope make themselves apparent in the table, inasmuch as the slope of the roof exerts a marked control over the direction in which a chimney falls.

Table showing the directions in which brick chimneys moved.

Chimneys which fell down the roof, <i>i.e.</i> with the roof-slope.			Chimneys which fell in a direction oblique or opposite to the roof'slope, and those shifting or jumping.						Total movement in all directions.	
Direction.	Number fell.	Per cent by directions.	Number falling obliquely to roof.	Number falling opposite to roof.	Number jumped.	Number shifted.	Total.	Per cent by directions.	Total number chimneys moved.	Per cent moved by directions.
NW.	175	31	8	4	10	5	27	10	202	24
SW.	121	22	15	7	8	1	31	12		
NE.	102	18	19	3	4	.....	26	10	128	15
SE.	133	24	14	7	2	2	25	9		
NNW.	1	0.25	15	.....	1	.....	16	6	17	2
WNW.	1	0.25	15	.....	.....	.....	15	6		
WSW.	.....	.....	6	.....	1	.....	0	2	14	1
SSW.	1	0.25	13	.....	.....	.....	13	5		
SSE.	.....	.....	12	.....	.....	.....	12	4.5	10	1
ESE.	.....	.....	10	.....	.....	.....	10	3		
ENE.	.....	.....	8	1	.....	.....	0	3	9	1
NNE.	1	0.25	12	1	.....	.....	12	5		
W.	5	1	21	1	1	.....	23	9	28	3
E.	7	1	10	.....	1	1	12	4		
N.	5	1	8	.....	1	.....	9	4	14	2
S.	8	1	19	.....	2	.....	22	11.5		
Total	560		205	25	31	9	270			
Southwest-northeast, 40 p. ct. Northwest-southeast, & 5 p. ct.			Northwest-southeast, 19 p. ct. Southwest-northeast, 22 p. ct.						Northwest-southeast, 43 p. ct. Southwest-northeast 33 p. ct.	
> 80 per cent of all that fell. 22 per cent of all that fell. 3 per cent of all that fell. 3 per cent of all that fell. < 7 per cent of all that did not fall.			Fell in known directions. . . . . 821 Caved away and fell in doubtful directions. . . . . 101 Total fell . . . . . 922 Shifted . . . . . 9 Stood without falling . . . . . 118 Total number of chimneys . . . . . 1049							

It will be seen from the preceding table that out of a total of 922 brick-chimneys that fell, 60 per cent went down the roof, while only 3 per cent fell in the opposite direction; 22 per cent fell obliquely, and 3 per cent with a leap apparently regardless of the roof. The predominance of the northwest and southwest directions, however, does not seem to be wholly due to the roof-slope. The table shows that in each division the northwest-southeast and northeast-southwest directions of movement are in the majority, even tho the chimneys have fallen in a direction contrary to the slope of the roof. The evidence here is not of the best, but there certainly seems to be a tendency toward motion in the same directions as those dominant in the case of the houses themselves. It may be supposed that chimneys fell in those directions owing to the movement of the house, but the majority of chimneys falling came from houses that were not dislocated.

The evidence of the chimneys falling obliquely, up the roof, shifting, and jumping was the best, since they moved without regard or in opposition to structural influence. Among these much the largest number of movements in any two directions were northwest and southwest, and the next largest number just opposite. The northwest-southeast and southwest-northeast movements, then, were in the majority, making a total of 41 per cent, while a majority of those remaining moved in directions intermediate.

*Movement of dishes, books, etc.* — Such loose articles as books, dishes, bric-à-brac, and lamps are, as a rule, free to fall or slide as they will, but in this region, especially in the town of San Mateo, the shelves on which many of them stood faced northwest, southwest, northeast, and southeast. The possible directions for falling in such cases were limited and this detracts somewhat from the value of the figures in the table.

Table showing percentage of directions in which dishes moved.

Direction.	Per cent moved, by directions.		Direction.	Per cent moved, by directions.	
NW.	22 \	491 } 89	W.	4 \	7 } 11
SW.	27 /		E.	3 /	
NE.	20 \		N.	151	
SE.	20 /		S.	2.5 /	
				4	

SW. to NE., 47 per cent; NW. to SE., 42 per cent.

Of objects overthrown, 89 per cent fell in one of these four directions. Tho many of the movements were determined solely by the direction in which the shelves faced, still the small number of movements in intermediate directions favors the idea that northwest and southwest and opposite movements predominate, for many of the cases recorded were of articles free to fall in any way whatsoever, and others were of articles that slid some distance along shelves without falling off. The east and west movements were more important than those north and south, showing a tendency in that way.

As to the cases in which dishes remained in position without appreciable shift on shelves facing in the four main directions of movement, the southwest-facing shelves were most of them left empty, and there was a much greater number of cases in which dishes remained stationary when it seemed natural for them to fall northwest, northeast, or southeast.

The case of a town library is especially worthy of mention: of books facing southeast, none fell; of those facing northwest, a few fell; of those facing southwest, all fell.

*Movement of furniture, etc.* — These data include facts concerning the direction of movement of pianos, stoves, tables, bookcases, beds, bureaus, counters, cases, mantel-pieces, safes, deposits of merchandise, and the like. These were generally free to move in all or most directions. The way in which the furniture was moved was learned at every house, and the results tabulated by regarding every direction of movement in any one house as a unit. Each unit, or case of movement, therefore, usually represents several individual movements.



Table giving data in regard to the moving of furniture.

Directions.	Percentage of cases in which furniture, etc., moved.	Number of cases in which articles, such as pianos, stoves, etc., moved.	Directions.	Percentage of cases in which furniture, etc., moved.	Number of cases in which articles, such as pianos, stoves, etc., moved.
NW.	19	14	SSE.	2	..
SW.	31	6	ESE.	0.3	..
NE.	18	4	ENE.	0.3	..
SE.	11	6	NNE.	0.3	..
NNW.	13	.	W.	5	*5
WNW.	13	2	E.	3	2
WSW.	20	..	N.	2	2
SSW.	13	..	S.	3	3

Here again the movements in northwest, southeast, southwest, and northeast directions far outnumbered all others. The total movements in these directions is 79 per cent. There were many cases of movements in directions slightly oblique to these, but tending the same way, which, if included, would swell the total. The southwest direction was much more frequent than the northwest, and the movements along southwest-northeast lines were much in excess of those at right angles. The west and east shiftings were more frequent than those to the north and south. The pieces of furniture moved in various ways, tipping over, sliding, and jumping. The movements were often back and forth. There is an apparently authentic case of a china closet tipping to the northwest, resting at an angle of about 60° against an obstruction, and tipping back to its original position. The number of heavy pianos, stoves, and safes which were moved is given in the preceding table. Sixty-six per cent of them were moved northwest and southeast and southwest and northeast. The evidence is especially good in such cases as the sliding of cash registers and scales on smooth counters, which in several instances went northwest, southwest, and southeast. The ornamental top of a soda fountain, balanced and free to fall any way, fell toward the southwest.

*Experiences and testimony of people.* — An earthquake comes and goes so suddenly and unexpectedly, and there are so many things to think about, even when one is able to formulate any thoughts whatever, that the description by people of the manner in which they felt the shock is apt to be only fragmental at best. It is the almost universal testimony in the San Mateo region that the first shock was followed by a lull, and that this was followed by a renewal of the motion in a different direction. Many state that the shock following the momentary lull was the heavier of the two. As to which of the two movements along lines northwest-southeast and southwest-northeast came first, little evidence has been forthcoming. Persons who agreed in regard to there being two successive directions of vibration differed as to which preceded. There were two cases of the spilling of liquids noticed by persons, and in both the statement was made that the liquid splashed toward the northwest at the first shock. In one of these cases the northwest splash was followed by one toward the southeast. A lady who was awake when the shock came said that things on the southeast side of the room began falling first. A jeweler declared that he was satisfied, from the movement of his pendulums, that the main shock was southwest and northeast. Two people were thrown out of bed in the same house, one of them being thrown northeast, the other southwest. One of these, after getting up, was thrown southeast from a standing position.

*Spilling of liquids.* — A form of evidence that could not be influenced by artificial position of any kind is that of the splashing of liquids. It is, however, evidence that is difficult to get at, partly because the signs of direction are so transient, and partly because even when they remain long enough to be seen, they are apt to be either carelessly or not at all observed. The 30 cases of spilling that were considered trustworthy and were recorded point to movements northwest-southeast and southwest-northeast.

Table showing directions in which liquids spilt.

Direction.	No. of cases of spilling.	Per cent, by directions.
NW. . . . .	6	20
SW. . . . .	6	20
Both NW.-SW. . . . .	1	3
NE. . . . .	4	14
SE. . . . .	4	14
Both NW.-SE. . . . .	4	14
Both SW.-NE. . . . .	5	17
ENE. . . . .	1	
W. . . . .	1	
Both E. and W. . . . .	1	
Both ESE. and WNW. . . . .	1	3
Total . . . . .	30	

SW. or NE., or both SW. and NE., 51 p. ct.; NW., or both NW. and SE., 34 p. ct.

In 20 per cent of the cases the liquid spilt northwest; in 20 per cent southwest; and in 3 per cent in both directions, making a total in these two ways of 43 per cent. Fourteen per cent spilt northeast, and 31 per cent northwest-southeast and southwest-northeast, in combination. This makes a total of 88 per cent in which spilling took place along the same lines in which movement in all previous cases predominated. The rest of the cases of liquids spilling tended the same way, none having gone north or south. The water in a reservoir was observed by one man at the time of the shock. He said the water seemed to move in waves toward the northeast, and that it splashed high on the northeast side of the reservoir. Others declared that waters were calmed by the quake. Tanks of water were repeatedly either wholly or partly emptied by the splashing of the contents. One lady states that her goldfish were thrown out of a little pool with the water, toward the east-northeast and west-northwest.

*Movement of various other bodies.* — This paragraph includes all important items of evidence that have not found a place in previous sections. It covers cases of falling, leaping, and sliding of towers, tanks, porches, pillars, underpinnings, gate-posts, arches, roofs, and the pulling apart of walls and partitions, besides the movement of many smaller articles. The evidence in most of these cases is especially good. For instance, a heavy marble slab on a counter slid lengthwise toward the northwest. A derrick which was leaning northeast was thrown toward the southwest. The following are the percentages in over 50 such cases: southwest, 35 per cent; northwest, 24 per cent; southeast, 17 per cent; northeast, 11 per cent; a total of 87 per cent for these 4 directions, while the other 4 directions, north, south, east, and west, total only 13 per cent of the movements. This is more evidence tending to the same conclusion as before; namely, that the southwest and northwest movements, and their opposite directions, far outnumber all others. In general, things that are thrown or that fall or slide freely furnish the best criteria for judgment as to the direction. The above list is largely made up of data of this kind. The cases of pulling apart of walls included are very few, for in the majority of instances in which parting of walls occurs the action is dependent on too many other factors.

*Predominance of northwest and southwest movements.* — It has been shown that the movements northwest and southwest, and those opposite, greatly exceed in number those in all other directions; and there is no question as to the predominance of the first two over those opposite to them in almost every case. It is clearest in the movement on foundations and the splashing of liquids. Evidence in regard to relative amounts

of movement in the first-mentioned directions and in those opposite seems to be best in the case of foundations, since loose articles may often have been thrown in the direction of an earthquake thrust, while houses moved opposite to it. The supposition is that houses usually shifted opposite to the thrust. Furthermore, it must be borne in mind that the contents of a building may be influenced by the movement of the building, rather than by the direct earthquake thrust itself, and thus give results pointing in the opposite direction.

*Cause of shifting.* — From the fact that northwest and southwest displacements were of most frequent occurrence, it seems likely that the main earthquake movements were southeast and northeast.

The fault which is believed to have caused the earthquake runs in a direction about N. 40° W., and passes within 3 miles of San Mateo. It will be noted that the dominant directions of movement were parallel and at right angles to the fault-line.

Evidence appears to show that in any one direction there was a succession of thrusts. In one instance, a bureau was jerked by successive small movements a distance of 6 feet toward the northwest. The course of such moving objects can often be traced by the marks left in dust. Some objects that were moved had returned to their original position when the end of the shock came.

*Relative intensity of the main movement.* — Considering only the northeast-southwest directions and those at right angles to them, we find that of all the houses that moved on their foundations, 31 per cent shifted southwest and northeast, and 27 per cent northwest and southeast. (See table on page 359.)

Of the chimneys that fell obliquely or upward with reference to the slope of the roof or that jumped or shifted, which gave the most trustworthy evidence in cases of falling chimneys, 22 per cent moved southwest and northeast, and 19 per cent northwest and southeast. The figures for all the chimneys give the predominance to movements in the northwest and southeast directions, but this fact is not significant, since the majority of roofs sloped in those directions.

Among the cases of liquids spilt, the southwest-northeast movement was greatly in excess of that northwest and southeast, 51 per cent of the total spilling in the former ways, and 34 per cent in the latter.

In addition to the evidence of the figures in other tables, that given in the table on page 361 may be cited. Forty-seven per cent of the dishes and similar articles went southwest and northeast, while 42 per cent went northwest and southeast. The same fact is indicated by the dishes that faced in these directions and did not fall. Fifty-eight per cent of the cases in which dishes remained standing on the shelves, when they were at liberty to fall in one or more of these ways, were cases in which they failed to fall northwest or southeast. According to the table on page 362, in 49 per cent of the cases of furniture movement the direction taken was either southwest or northeast, or both; whereas it was northwest or southeast in only 30 per cent of HUCI cases.

The following table enumerates the cases in which houses moved a distance of more than 0.25 inch on their foundations; in other words, the worst cases of the kind. It gives the sum of the distances moved in each direction.

Among the most serious shifts, those to the southwest predominate slightly in number and distance over the northwest ones, but owing to the excess of southeast movements over those to the northeast the percentages for the combined opposite movements are just the same — 37 per cent in each case. Numerous houses shifted both southwest and northwest, but different distances each way. In exactly half of the cases the movement southwest was greater, and in the other half that of the northwest movement was in excess, while the average distance moved either way was the same.

*Number of cases in which houses moved measurable distances on their foundations in different directions, and average distance moved.*

Direction.	Number of houses moved.	Average distance moved (inches).	Total moved and percentage by direction.		Average distance moved (inches).
				Per cent of total.	
NW.	31	1.19)	84	69	1.15
SW.	39	1.05/			
W.	14	1.36)			
NE.	6	1.91)	29	24	1.39
SE.	14	1.29)			
E.	9	1.22)			
N.	4	2.37)	9	7	1.50
S.	5	.80/			
Total.	122	1.24			

Southwest-northeast, 45 = 37 p. ct. of total; northwest-southeast, 45 = 37 p. et. of total. The entire number moved in first three and opposite directions was 113, or 93 p. ct. of total.

INTENSITIES.

The houses covered by this study may be grouped in three divisions, according to locality: those on the hills at Burlingame and San Mateo heights; those at Belmont, Homestead, and San Carlos, which are partly on the level valley land and partly on the low hills; and those at San Mateo and Redwood City, on the valley-floor. The data indicate strongly that the intensity of the shock was less on the hills than on the flat, in spite of the fact that the houses on the hills were nearer the fault-line. In fact, several houses on the rock-formed hills very near the earthquake fracture did not give evidence of any greater intensity than those at San Mateo.

The Buri-Buri Ridge, as the hills are called, is composed of an old and very much compacted series of sedimentary rocks, sandstone, shale and jasper, and of serpentines. Moreover, they are not deeply covered with soil, so that they form a strong foundation for the houses.

The percentage of houses that moved on their foundations on the hills was 6 per cent; and at Belmont, etc., 3 per cent moved, as against 27 per cent at San Mateo and Redwood City. This is shown in the table on page 355. Among the very few houses that shifted on the hills and in the Belmont region, only 4 or 5 moved an appreciable distance, while in a majority of cases in the valley the movement was considerable.

From the figures given in the table on p. 356 it appears that of the chimneys, 73 per cent fell on the hills, 88 per cent in the intermediate settlements, and 92 per cent in the valley. The intensity of the shock, as shown by the amounts of falling of dishes and cracking of plaster, was greater in the flat country. The following table gives the percentage in these cases. Of course the classification of the damage is very arbitrary and the figures at best are but indicative. Of cases recorded in which furniture failed to move appreciably in houses, 90 per cent were on the hills.

*Degrees of damage to plaster and household articles on hills and low lands.*

AMOUNT or DAMAGE.	SAN MATEO AND REDWOOD.			BUYER HILLS, ETC		
	Slight.	Medium.	Great.	Slight.	Medium.	Great.
Percentage in cases of cracking of plaster	40	30	30	79	11	10
Percentage in cases of falling of dishes, etc., in varying amounts	40	20	40	74.3	23.3	2.3

The testimony is good in all cases that structures on the hills suffered less severely from the earthquake than those on the plain. If a large amount of similar data could be collected on the low, alluvial, often marshy, flat land bordering the bay, it would probably be shown that the movement there was still more intense. Houses, however, are not frequent there. In low bottom-land there were indications of great intensity, and especially in the case of ground artificially filled in. A good example was given by the electric railroad track a few miles north of San Mateo, shown in plate 97c, D. It was built over the low land on a heavy, but loose, embankment of earth and stone. At one place this roadbed was shaken apart between the rails, and a crack from 1 to 2 feet wide and extending down many feet, nearly if not quite to the level of the valley, was formed in it for a distance of over 1,000 feet. It ran northwest and southeast, parallel with the road, and thruout that stretch not one of the heavy steel rails was left unbent. One 30-foot rail that was examined had been bent 2 feet horizontally and 10 inches vertically. Such wrecking of railroad tracks occurred wherever the underlying foundation was loose, but the stretches of track on solid ground were not affected. The low, muddy land along San Francisco Bay, east of San Mateo, was seamed with cracks by the earthquake.

#### CONCLUSION.

The following are the main conclusions arrived at in the course of the work:

1. It is evident that much of the damage to houses, as well as to their contents, could be avoided by judicious construction. The disadvantages of certain classes of structure should be acknowledged, and search made for more successful styles. Houses practically earthquake-proof can be built easily and cheaply.
2. The dominant directions taken by moving bodies during the course of the earthquake shock were southwest and northwest, with movements northeast and southeast only second in number. There appear to have been felt in this region two main thrusts or sets of movements that emanated from the fault-line in southeast and northeast directions.
3. The shock was less heavily felt on the hills than on the level land. The lower slopes were affected in an intermediate degree. The difference in the two extremes was probably almost as much as one degree of intensity in an earthquake table of 10 units.

## DIRECTIONS IN THE TOMALES-BOLINAS DISTRICT.

BY G. K. GILBERT.

The greater number of my notes as to direction of motion pertain to the shifting of houses which left their foundations. Most of the houses in this district which were thus shifted stood on light, vertical, wooden piers or props, and fell from their props in shifting. The direction of falling was so frequently downhill as to show that the slope of the ground was an important factor, and this fact leads me to give little weight to data of this character. There were, however, a few houses which, resting upon flat, unyielding foundations, were shifted horizontally upon these, and their evidence is of greater value. I think also that some weight should be given to the dominant direction in which houses of a group were thrown from their supports.

Other data as to direction are found in the falling of men and animals, and these seem to me of value wherever a dominant direction affected a group of individuals. The direction of fall of a single individual might readily be conditioned by muscular reactions, and thus give little evidence as to the direction of the strongest tremor.

I am led to question evidence from the shifting of furniture and the throwing down of objects on shelves, because in every instance the direction of vibration of a building appeared to be controlled partly by its structure. In view of these considerations, I regard the greater number of my observations on direction as of little significance, and do not report them.

The clearest data as to direction are at Inverness. While there was much variety in the direction of motion of houses at that locality, it was quite clear that the dominant direction was westward. This also was the direction toward which 4 out of 5 water-tanks were shifted, and it was the direction toward which the mud on the bottom of Tomales Bay was moved. The locality is within less than 1 mile of the fault-trace and is on the southwest side.

At Point Reyes Station, situated 0.25 mile northeast of the fault-trace, the dominant direction of shifting was southward, and an exceptionally definite record was made by the school-house, which rested on a firm, flat foundation and was slid toward the south.

At Olema, 2 miles southeast of Point Reyes Station and similarly related to the fault-trace, the dominant direction of motion was southwest, or toward the fault, the best single instance being that of a pool of water which spilt in that direction.

At Dipsea Inn, 0.66 mile northeast of the fault, a pier running northeast from the spit was wracked toward its outer end. A line of telephone poles crossing the lagoon from the end of the pier was slanted in the same northeast direction. In the Inn objects were thrown southwest, and of three cottages injured two were shifted or wracked to the southwest. On the mainland nearby a part of Mr. Morse's pier was wracked to the southwest. Collectively these facts indicate a dominant vibration to and from a northeast direction.

At Willow Camp, close to the east angle of Bolinas Lagoon and about a mile northeast of the fault, several houses moved short distances toward the southeast.

These various directions are platted in fig. 65.

## DIRECTIONS INDICATED BY MONUMENTS IN CEMETERIES.

Prof. F. Omori attempted to determine the directions of the earth's vibrations by a statistical study of the thrown monuments in the cemeteries south of San Francisco. The results of his investigations are shown graphically in fig. 66, in which it appears that the greater number of monuments were thrown in the quadrant between northeast and southeast. The mean direction of overthrow is N. 76° E., which is regarded

as the direction toward which the greatest horizontal displacement took place due to vibration. Other observations on the directions of the vibratory movement may be found in Professor Onion's paper.<sup>1</sup>

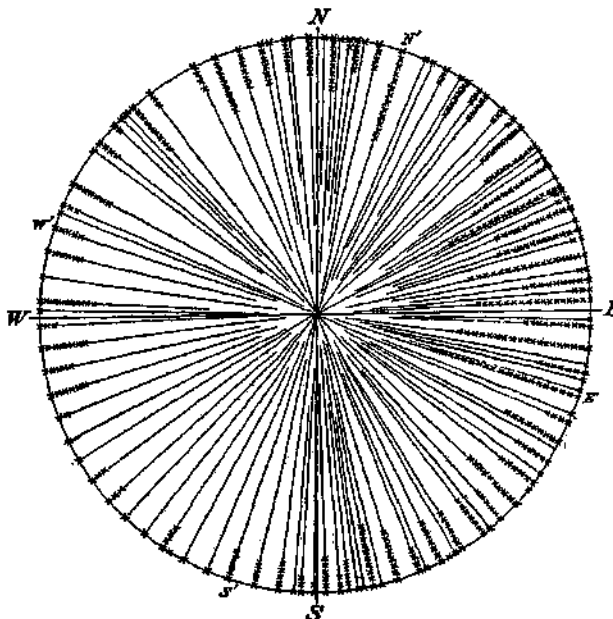
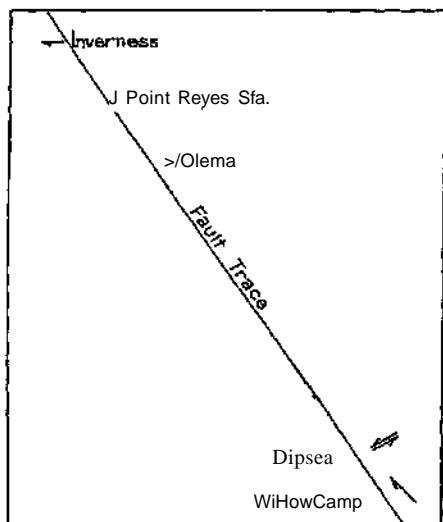

FIG. 65.—Directions of earthquake motion. FIG. 66.—Statistical representation of the directions of fall of monuments in the cemeteries south of San Francisco. Each x represents a monument which fell in the direction indicated by the radius on which the x is placed. After Omori.

Preliminary note on the cause of the San Francisco earthquake of April 18, 1906. Bull. Imo K I. C, Vol. I, No. 1.

## MARINE PHENOMENA.

*The effect of the earth movement on the sea-level.* — In earthquakes along coastal regions the waters of the ocean are usually affected, particularly if there be a displacement of the sea-bottom. If the displacement has a considerable vertical component, so that one portion of the sea-bottom is dropt relatively to an adjacent portion, the ensuing displacement of the prism of water over the region affected will generate a periodic wave, which will cause the water along the coast to rise and fall with more or less disastrous results. If the dropt portion of the sea-bottom is on the landward side of the fault upon which the displacement occurs, the wave will be greater for the same amount of displacement than if the drop is on the seaward side. If, however, the vertical component of the displacement is quite small, and the movement is chiefly horizontal, as in the case of the fault of April 18, 1900, the sea-wave will be correspondingly insignificant.

The bottom of the Gulf of the Farallones, which was traversed by the fault from Bolinas Lagoon to Mussel Rock, comprizes the inner shallower portion of what is known as the 100-fathom plateau off the coast of California. This plateau stretches seaward, with an average breadth of 22 miles, immediately off the short line of coast from Pigeon Point, in latitude  $37^{\circ} 11'$ , to the mouth of Russian River, in  $38^{\circ} 20'$ , a distance of about 80 geographic miles. The area of this part of the plateau is about 2,500 square miles, which includes the area of the Gulf of the Farallones, about 1,200 square miles. On it lie the Southeast Farallones, the North Farallones, Noonday Rock, and the Cordell Bank, having a northwest and southeast bearing thru 30 geographic miles. The line projected southeastward strikes Pigeon Point. (See map No. 4.) The summits of the Farallones rise as much as 340 feet above the sea; Noonday Rock has 3 fathoms of water over it, and the Cordell Bank has 19 fathoms. Inside of these islets there is a very uniform bottom of sand, with a gradually decreasing depth of water toward the shore. Outside of the islets the grade of the bottom rapidly increases. The 100-fathom line reaches 5 miles to the southwest of the Southeast Farallones; thence it is 10 miles to 500 fathoms and 29 miles to 1,728 fathoms.

There is no means of directly ascertaining the amount of the vertical component of the fault of April 18 for those portions of the fault-trace which lie on the sea-bottom across the Gulf of the Farallones or in the region to the northward. But where it traverses the land to the south of Mussel Rock, there is no evidence of vertical displacement; and to the north of Bolinas Bay, while there is evidence of an uplift on the west side of the fault, that uplift is slight, not exceeding 1 or 2 feet. The absence of a periodic wave at the Golden Gate indicates that the vertical displacement on that segment of the fault which crosses the Gulf of the Farallones, if there was any, was very small. While there was no periodic wave of the oceanic water generated by the horizontal displacement of the sea-bottom, there was an interesting disturbance of the level of the sea, shown by the tidal gage near Fort Point on the south side of the Golden Gate, which is probably to be classed with the secondary phenomena arising from the displacement.

The tidal gage yields a record known as a marigram, upon which is chronologically indicated the rise and fall of the water in the Golden Gate with the incoming and outgoing of the tide. The record is said to be sensitive to the impact of waves breaking upon the bar outside the heads distant some miles from the gage. It is also sensitive to the conflicting volumes of water from the north and south parts of the Bay, when these are striving for mastery on the fading tide. Former submarine earthquakes in distant parts of the Pacific have generated waves which have been recorded on the



marigram at the Golden Gate. The marigram near Fort Point, for April 18, 1906, shows (fig. 67) a depression of the water-level in the Golden Gate at the time of the earthquake, or rather a little subsequent to that event. The amount of the depression was slightly in excess of 4 inches. The marigram shows a blurring of the pencil mark from the direct action of the earthquake agitation, and this bearing serves to give approximately the time of the shock. It shows that the running clock of the gage was probably too slow, and that the depression of the water-surface did not begin instantaneously, but followed after an interval which may have been from 9 to 10 minutes. Before the shock the gage had had a small vertical movement, ascribed by the officers of the Coast and Geodetic Survey to an imperfect oscillation across the Golden Gate. This minor vertical movement continued during the drop in the level of the water after the shock. The time for the lowering of the water was 9 minutes, as near as can be read from the marigram. It immediately began to recover, and the record shows that the water level rose without minor oscillations, to the normal level within 7 minutes, the total interruption in the normal marigram curve due to this depression being 16 minutes. After full recovery to normal level, the depression was not followed by a complementary rise of the water-surface, and in this sense the movement was not periodic. The minor oscillations referred to above ceased when the maximum depression was reached, and do not appear in their characteristic forms on the marigram curve for some hours after. They were replaced, however, after 6 o'clock, by 2 or 3 oscillations having a period of about 40 to 45 minutes and an amplitude of 1 to 2 inches. These probably correspond to oscillations in San Francisco Bay.

The Tidal Division of the Coast and Geodetic Survey very kindly computed the time which would be required for a wave generated at the fault-line on the bottom of the Gulf to reach Fort Point, and found that it would require 9 minutes, on the assumption that Fort Point is 6 statute miles distant from the fault-trace in a direction normal to it. The position of the gage is, however, 1.3 miles distant from Fort Point within the Golden Gate, so that the time necessary for the wave to reach the gage would be somewhat longer. Now the time at which the gage began to fall is between 9 and 10 minutes

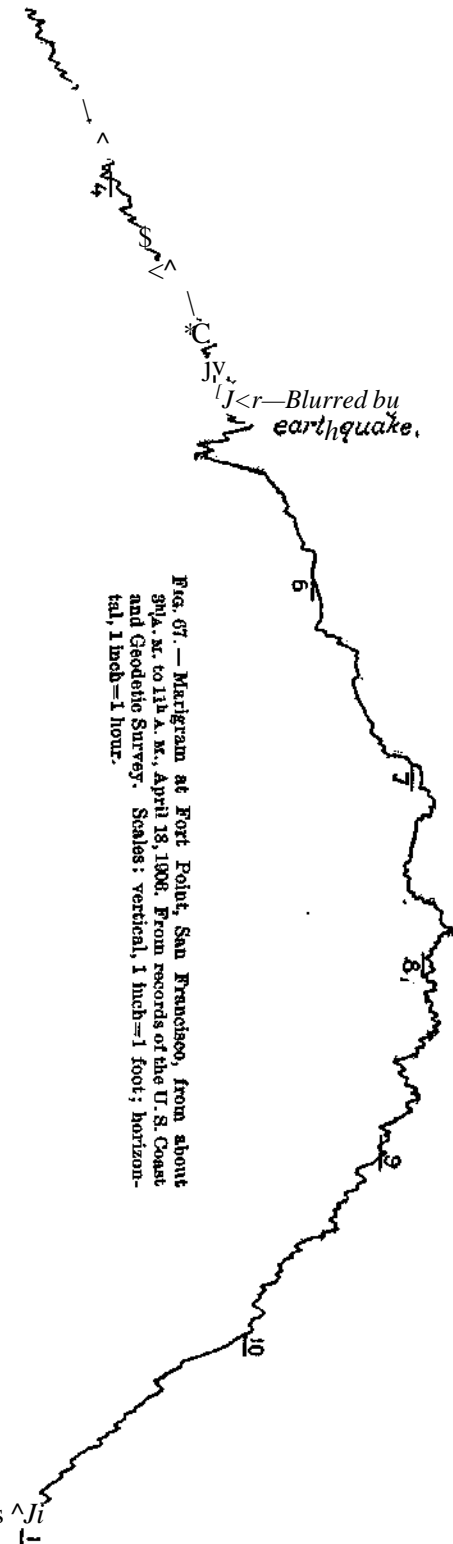

Fig. 67.—Marigram at Fort Point, San Francisco, from about 9 P.M. to 11 A.M., April 18, 1906. From records of the U. S. Coast and Geodetic Survey. Scales: vertical, 1 inch=1 foot; horizontal, 1 inch=1 hour.

after the first interruption and blurring of the record by the shock itself, and this coincidence in time suggests that the fall in the water near Fort Point was due to a negative oscillation generated at the line of the fault. The effect produced would have been brought about had there been a slight drop of the sea-bottom on the outer side of the fault. But there is independent evidence, to the north and south of this particular segment of the fault, that there was no drop on the west side, so that this explanation can not very well be entertained.<sup>1</sup> It is also possible that the effect observed might have been brought about by a slight expansion of the confines of the Gulf of the Farallones, due to the differential movement along the fault, but this would not explain the coincidence in time. The period of the east-west oscillation of the waters in the Bay of San Francisco, between West Berkeley and Fort Point, has also been computed by the Tidal Division of the Coast and Geodetic Survey to be about 40 minutes. This agrees fairly well with the two or three oscillations recorded by the gage after 6 o'clock, and indicates that the drop of the water-surface outside of the Golden Gate generated an east and west oscillation in the Bay of San Francisco.

Tidal observations conducted at Fort Point for a period of 1 year from the date of the earthquake indicate that there was no change of the relative altitude of sea and land at that point, as compared with the conditions prevailing during the 3 years preceding. A review of the observations for the past 9 years, by the Coast and Geodetic Survey, reveals, however, the interesting fact that in that period of time there has been an apparent subsidence of the coast at that point of 4.8 inches, practically all of this having been accomplished in the first 6 years of this period. There has been no movement in the last 3 years. (April 18, 1907.) The only other tidal gage maintained on the coast of California is that at San Diego, and the marigram obtained there shows no abnormal movement of the surface of the sea referable to the earthquake.

The only other report indicating that the level of the ocean was affected along the coast is by W. W. Fairbanks, of Point Arena, who says: "I have endeavored to learn of any unusual action of water along the sea-coast, and can relate but one instance of anything approaching the character of a tidal wave. On the day of the shock I traveled by wheel and on foot from Albion to Point Arena, 25 miles. At the mouth of Navarro River, at 8 o'clock on the morning of the 18th, I learned from reliable sources that a section of about 10 acres of low, flat land about the mouth of this river was entirely submerged for some minutes immediately after the shock."

*The shock felt by ships.* — Information regarding the perception of the shock on ships at sea or in harbors has been collected by Prof. George Davidson, and the following notes are chiefly the result of his inquiries:

The XI. S. T. S. *Pensacola*, moored to the pier at the U. S. Naval Training Station, Yerba Buena Island, San Francisco Bay, felt the shock on the morning of April 18, 1906. Surgeon L. W. Curtis reports that while in bed on the *Pensacola* he felt a vibratory shock lasting about 30 seconds, with one heavy jar about the middle period of the shock. A gentle rumbling sound coincided with the shock. The phenomenon closely resembled vibrations which are at times set up in the ship's hull on starting the dynamo, and it was mistaken for that, tho much more active and exaggerated than ever before observed. The vibration shook down some loosely piled books and papers from a table.

<sup>1</sup>This explanation is, however, advocated by Prof. H. F. Reid. In a note received while these pages are in proof he says: "If a depression occurred on the western side of the fault-line, extending for some distance to the westward, it would start a wave of depression towards the Golden Gate which would take 9 minutes to reach Fort Point and this is just about the time recorded by the gage. The time necessary for the recovery to normal level would depend upon the extent of the area depressed. If this were a narrow block, a wave of elevation would follow quickly upon the wave of depression and we should have a rapid elevation of the tide-gage above its normal position. As no such wave appeared and recovery was very gradual we must suppose that the deprest area extends for some distance to the westward, so that the recovery was slow. This is the only explanation so far offered, that would produce the effects observed."

The pilot-boat *Gracie S.* was lying in 18 fathoms of water near the lightship off the San Francisco Bar. She was suddenly struck by a seaquake which caused her to quiver as if the chain were running out of the hawser pipe. When the pilot boarded the German Cosmos steamship *Nyada*, the captain reported that his vessel had been shaken as if she had struck on rocks. The pilot-boat *Pathfinder* was lying in the vicinity, in 20 fathoms, and reported the same effect.

The steam collier *Wellington*, inward bound, between Fort Point and Point Diablo, in 50 or 60 fathoms, reported that the vessel was struck as if she were upon rocks. (Personal report of Captain Hayes, of the Board of Pilots.)

The steamer *Alliance*, off Cape Mendocino, reported by Mr. H. H. Buhne, of Eureka: The captain said she was struck a hard blow, as if she had run on a rock at full speed; time, 5<sup>h</sup> 11<sup>m</sup>. Mr. Buhne states that all ships in the harbor at Eureka felt the quake, but in South Bay it was heaviest. One vessel was hurled against the wharf time and again, throwing down piles of lumber and shingles.

The schooner *Joltn A. Campbell* felt the shock at sea, off Point Reyes. The following is a memorandum of the event by Capt. C. J. S. Svenson: "Ship's local apparent time April 18, 1905, 5<sup>h</sup> 15<sup>m</sup> A. M. Lat. 38° 00' N. Long. 126° 06' W.; 145 miles true west of Point Reyes. Weather fine; sky clear; wind fresh from north-northwest; sea moderate; ship's course southeast; speed 7 miles per hour. The shock felt as if the vessel struck lightly forward and then appeared to drag over soft ground, and when aft a slight tremor was felt; the whole lasting only a few seconds." The depth of water in the vicinity of the ship's position is 2,400 fathoms.

The steamship *National City* was approximately in lat. 38° 24' N. and long. 123° 57' W; 29 geographical miles distant from the nearest point on shore and about 31 miles from the fault-trace along the valley of the Gualala River. The vessel felt the shock at 5<sup>h</sup> 03<sup>m</sup> A. M., April 18, 1906, ship's time. James Denny, the chief engineer, supplies the following comment: "The ship seemed to jump out of the water; the engines raced fearfully, as though the shaft or wheel had gone; then came a violent trembling fore and aft and sideways, like running at full speed against a wall of ice. The expression 'a wall of ice' is derived from my experiences in the Arctic." In this vicinity the chart has several soundings, as follows: 911 fathoms over clay and mud at 11.5 miles on the line to Gualala Point; 1,586 fathoms over clay and ooze 8 miles north by compass; 1,821 fathoms over clay and ooze 14 miles N. 54° W. by compass.

The wharfinger at Santa Cruz reports that he heard a rumble before the shock, coming from the southeast, and saw the seismic wave traveling shoreward, causing a great rattling and crashing when it struck the town. Two distinct sets of vibration were felt, the latter being the harder. There was very little surf, the water looking like that in a tub when jarred. The wharf, extending southeast, seemed to pitch lengthwise. A steamer between Santa Cruz and Monterey, also one at Monterey wharf, felt the shock; it jarred them as if they had struck bottom.

*Shocks felt at sea subsequent to April 18, 1906.* —The ship *Alex Gibson*, at 7<sup>h</sup> 05<sup>m</sup> P. M. August 8, 1900, when in lat. 25° 35' N., long. 110° 06' W., experienced a tremendously heavy seaquake, lasting about 40 seconds and shaking the ship from stem to stern as if she were bumping over a ledge of rocks. It shook tools out of the racks in the carpenter shop; throw pots and pans down in the galley, cups and pitchers from hooks in the pantry, and all lamp glasses off the lamps. The crew came running aft not knowing what was the matter, and the captain thought the yards were coming down. The sea at the time was perfectly smooth, the wind light from the southwest, no land in sight, and all sail set in fine, clear weather. At 7<sup>h</sup> 10<sup>m</sup> r. M., ship's time, another light shock was felt, of about 15 seconds duration; and from 8 to 12 midnight two more very light shocks were felt, but the time was not noted. The captain states that he had experienced

an earthquake at sea on a former occasion, but the one felt before was nothing compared to this one, either in force or duration. (Hydrographic Bureau.)

The bark *St. James*, Capt. 3<sup>d</sup>. O. Parker, while in lat. 26° 19' N., long. 110° 25' W., in the Gulf of California, on August 26, 1906, was shaken by a seaquake at 12<sup>h</sup> 15<sup>m</sup> p. M. The shock lasted a minute, and the sensation was as if the vessel were striking upon sunken rocks. Upon arrival at Guaymas, the captain learned that no shock had been experienced at or about the time noted. (*San Francisco Chronicle*, Sept. 16, 1906.)

The bark *Agate*, Capt. C. H. McLeod, while off the northwest coast in lat. 43° 10' N., long. 128° 50' W., 100 miles west of Coos Bay, experienced a heavy shock on September 2, 1906, at 3<sup>h</sup> 45<sup>m</sup> A. M. The shock lasted nearly 1 minute. The sensation was as if the vessel had struck a coral reef or rock. The wind was light, the weather clear, and the sea smooth. At 3<sup>k</sup> 55<sup>m</sup> A. M., another shock was felt, not so severe nor so prolonged as the first. (*San Francisco Chronicle*, Oct. 2 and 9, 1906. Hydrographic Bureau.)

The ship *Robert Searles*, Capt. J. H. Piltz, while in lat. 41° 78' N., long. 125° 52' W., 85 miles northwest of Cape Mendocino, experienced a severe shock on September 14, 1906, which occasioned a panic among the crew. The cargo (lumber) and upper works of the vessel were shaken. The shock lasted 25 seconds. (*San Francisco Chronicle*, Sept. 17, 1906. Hydrographic Bureau.)

The American schooner *Stanley*, Capt. K. Petersen, while in the calm center of a cyclone, in lat. 46° 09' N., long. 125° 22' W., 55 miles west of Cape Disappointment, on November 6, 1906, felt a sharp shock that lasted 2 or 3 seconds. Immediately afterwards, when looking toward the southwest, the captain saw 3 mountainous waves coming; when they struck, the ship began to pitch and roll violently, and he thought every minute she would be swamped. (Hydrographic Bureau.)

The schooner *Melrose*, Capt. M. McCarron, while in lat. 37° 35' N., long. 123° 35' W., felt a seaquake on February 3, 1907. The first shock was at 10<sup>h</sup> 30<sup>m</sup> A.M., lasting about 8 seconds; and the second at 10<sup>h</sup> 50<sup>m</sup> A.M., lasting about 5 seconds. Neither shock was violent, but each caused a decided trembling of the vessel. The motion was from east to west. The sky was overcast and the sea was smooth, with light westerly winds. The position of the vessel was 28 geographical miles S. 73° W. from the Southeast Farallon. The nearest sounding on the chart is 5 miles north of this position, where there is shown 1,726 fathoms of water.

## NUMBER OF MAXIMA IN THE MAIN SHOCK,

In response to various circulars sent out by the Commission, and to direct inquiries by the members of the Commission or their aides in the field, 154 replies have been received, which constitute testimony as to whether the main shock comprized one or more maxima. Many of these replies are rather questionable scientific evidence, inasmuch as many of them were in response to a leading and suggestive question, and very few of them have been subjected to the clarifying process of cross-examination. So few people were awake at the time the shock began that but a small proportion of the replies come from people who were in full possession of their observational faculties at the beginning of the disturbance; and of those who were suddenly and rudely awakened, few were sufficiently alert for deliberate perception at the time and had to rely upon a somewhat confused memory for the character of the shock. Yet the testimony is of value, and indicates a very general consensus of the impression that there were 2 principal maxima in the shock; and the failure of many to recognize or remember 2 parts to the shock does not seriously invalidate the testimony of those who received that impression.

Of the 154 replies received, 98 testify to 2 maxima; 46 to but one maximum; 9 to 3 or more maxima; and 1 to more than one. Of the 98 who reported 2 maxima, 67 discriminated between the 2 parts of the shock, as to their relative intensity; and of these 67, there were 48 who had the impression that the second maximum was the more severe, and 19 who thought it the less severe. Of the 46 who recognized only one maximum, 32 were beyond the zone of destructive effects, where the intensity was VI or less (in a few cases VII); and of the remaining 14 cases within the zone of destructive effects, 11 were offset or contradicted by other reporters in the same general district as themselves, who record two maxima. It would thus appear that within the zone of destructive effects, say out to isoseismal VII, the evidence, such as it is, points unmistakably to the occurrence of 2 maxima; and the prevailing opinion is that the second was the stronger. The failure on the part of many reporters to discriminate 2 parts of the shock beyond the isoseismal VII is not surprising, and is offset by the considerable number of reports in which 2 maxima were noticed.

*List of observations as to the number of maxima in the earthquake shock.*

Locality.	Reporter.	No. of Maxima.	Remarks.
Nolton .....	Clara Ward.....	2	Second stronger.
Crescent City.....	G. Sartwell.....	2	Interval about 2 seconds.
Montague.....	C. H. Chambers ..	1	Duration 30 seconds.
Upton.....	G. K. Dixon.....	1	
Big Bar.....	W. A. Pattison...	2	A tremor which eased up, then another stronger.
Papoose.....	C. S. Lakemore...	1	
Eureka.....	A. H. Bell.....	1	Maximum intensity toward end; duration 47s.
Fortuna.....	J. L. Thomberry..	2	One greater than the other.
Peppenvood.....	J. F. Helms.....	2	Second stronger.
Brieland.....	J. W. Bowden.....	2	Second stronger.
Fort Bragg.....	E. Higgins.....	2	Continuous shock, 40 s., ending with eavy one.
(Jcn Bkiir.....	A. P. Scott.....	1	
Albion.....	J. Covie.....	1	
Pliilo.....	J. L. Prather.....	2	About the same intensity.
Fi-h Kock.....	J. L. McII.....	2	Second stronger.
Annapolis.....	G. V. Fiscus.....	2	First in wave motion; second rotatory.
Fort Koss.....	O. W. Call.....	Several	Increased in force up to third or fourth.
Cazadero.....	E. H. L. Cowlev..	2	Second stronger.
Hemlock.....	C. J. L. Bowen...	2	Second stronger.
Cloverdale.....	M. C. Bale.....	Several	Oscillatory, ending with series of shocks.
Lakeport.....	J. Overholser.....	1	
Sanhedrin.....	V. L. Fra?4er.....	1	
Oathill.....	J. J. Hulter.....	2	Second stronger.
St. Helena.....	F. Blachow.-ki....	2	Second stronger.
Veteran's Home ..	A. Bruwn.....	1	
Wooden Valley ...	H. W. Chapman..	2	First stronger.
Cotati.....*	C. L. Jeffrey.....	1	

## List of observations as to the number of maxima in the earthquake shock—Continued.

Locality.	Reporter.	No. of Maxima.	Remarks.
Vallejo . . . . .	J. J. Lindunger . . . . .	2	Increase in severity in latter half.
Tamalpais . . . . .	W. W. Thomas . . . . .	2	If any difference, first stronger.
San Rafael . . . . .	L. Reubold . . . . .	2	First light and long, second hard and short.
do . . . . .	E. Landon . . . . .	1	
do . . . . .	A. Scott . . . . .	2	First light, second heavier.
do . . . . .	G. L. Richardson . . . . .	2	First heavier.
do . . . . .	F. M. Watson . . . . .	2	First lighter and longer than second.
do . . . . .	J. D. Bennett . . . . .	2	First heavier.
San Mateo . . . . .	B. A. Peckham . . . . .	3	First and second were heavy wavy motions; third was short rapid trembling.
do . . . . .	R. Anderson . . . . .	2	Two main thrusts or sets of movements.
Mountain View . . . . .	A. M. Free . . . . .	2	Second stronger.
Woodside . . . . .	H. O. Beaty . . . . .	2	Personally observed but 1; others observed 2 or 3 and there is a general agreement that second was stronger.
San Jose . . . . .	J. C. Hartzell . . . . .	2	Second more intense.
do . . . . .	M. Connell . . . . .	1	Came suddenly, explosion-like, then a violent swaying.
Santa Clara . . . . .	J. S. Ricard . . . . .	2	Two shocks, then finally a twist and an uplift.
Campbell . . . . .	F. M. Richter . . . . .	2	Second stronger.
Los Gatos . . . . .	F. H. McCullogh . . . . .	1	Wife noticed a preliminary shaking.
do . . . . .	I. H. Snyder . . . . .	2	Partial intermission of 1 or 2 s. Second much stronger.
do . . . . .	W. S. T. Smith . . . . .	2	Interval was not sufficient to allow moving objects to come to rest.
Skyland . . . . .	T. Wightman . . . . .	1	
New Almaden . . . . .	J. F. Tathan . . . . .	2	Second stronger.
Wright . . . . .	Mrs. A. L. Sears . . . . .	1	Followed by tremors.
do . . . . .	Flora E. Beecher . . . . .	2	About equal.
Gilroy . . . . .	W. J. Lawler . . . . .	2	Second stronger.
Sargent . . . . .	W. B. Stuart . . . . .	2	First stronger.
Hollister . . . . .	J. N. Thompson . . . . .	2	Almost continuous; second did most damage.
Tres Pinos . . . . .	G. A. Waring . . . . .	2	
Paicenes . . . . .	do . . . . .	1	
(4 miles SW.) . . . . .			
Bear Valley . . . . .	do . . . . .	3	Noted by several people.
Bitterwater . . . . .	C. Z. Smith . . . . .	2	Second stronger.
Hernandez . . . . .	E. M. Tucker . . . . .	2	First part gentle, second more severe.
Mt. Hamilton . . . . .	H. K. Palmer . . . . .	2	First harder; memory uncertain.
do . . . . .	A. M. Hobe . . . . .	2	Jar, then pause, then tremble.
do . . . . .	W. W. Campbell . . . . .	2	First harder.
Calaveras Valley . . . . .	R. Ingleson . . . . .	2	2 separate shocks.
Livermore . . . . .	E. G. Still . . . . .	2	
Danville . . . . .	A. E. Clark . . . . .	2	Second stronger.
Mt. Eden . . . . .	W. Gaily . . . . .	2	First sideways, second upward.
Mills College . . . . .	J. Keep . . . . .	1	
Berkeley . . . . .	A. C. Lawson . . . . .	2	First prolonged, with secondary maxima; second brought down chimneys and ended rather abruptly.
Bolinas . . . . .	J. G. Peter . . . . .	2	Second stronger.
Farallones . . . . .	J. A. Boyle . . . . .	2	First stronger.
Santa Cruz Range . . . . .	M. Doyle . . . . .	2	Tremor, then distinct shock; then violent shock, then tremor.
Bellvale . . . . .	Lilla E. Bell . . . . .	2	Continuous shake with 2 heavy parts.
Santa Cruz . . . . .	G. A. Waring . . . . .	2	Second stronger.
do . . . . .	O. J. Lincoln . . . . .	2	
Delmas . . . . .			
Seabright . . . . .	G. A. Waring . . . . .	2	Shook came suddenly, diminished, then at a second jolt the chimneys fell.
Twin Lakes . . . . .			
Bonnie Doon . . . . .	T. IL Thayer . . . . .	2	Second stronger.
Soquel . . . . .	Matilda Baker . . . . .	2	First stronger.
Ben Lomond . . . . .	I. R. Guichard . . . . .	2	Second stronger.
Watson villo . . . . .	E. McCabt* . . . . .	1	
Castro ville . . . . .	G. A. Waring . . . . .	1	Felt as 1 continuous vibration.
Prunedale . . . . .	II. H. McIntyre . . . . .	2	Second stronger.
Salinas . . . . .	Bertha M. Abbott . . . . .	2	Si'niul stronger.
Monterey . . . . .	N. W. James . . . . .	2	First stronger.
Chualar . . . . .	G. P. Anderson . . . . .	2	
Ixmonk . . . . .	J. RLst . . . . .	1	Continuous shock, light at first; finishing with a hard stn.»kt' and twist.
Shandon . . . . .	(J. J. Shaw . . . . .	2	

## List of observations as to the number of maxima in the earthquake shock — Continued.

Locality.	Reporter.	No. of Maxima.	Remarks.
San Luis Obispo...	S. D. Ballou . . . . .	1	
do . . . . .	J. R. Williams . . . . .	1	50 seconds long.
do . . . . .	M. R. Venable . . . . .	2	Slight tremor; then a second more severe; then a distinct oscillation, quite hard; then a tremor.
Santa Maria . . . . .	F. R. Schanck . . . . .	3	First and second, 1 or 2 s.; third, 12 to 15 s.
Pismo . . . . .	Emma M. Patchett . . . . .	2	Second stronger.
Lorapoc . . . . .	A. McLean . . . . .	1	One long shock.
do . . . . .	C. K. Studley . . . . .	2	First gradually increased to maximum and gradually decreased. Second died suddenly.
Santa Barbara—	J. A. Dodge . . . . .	1	About a minute long.
do . . . . .	S. F. Hunt . . . . .	3	Second strongest.
Los Angeles . . . . .	W. D. Fuller . . . . .	1	
Compton . . . . .	L. A. Rockwell . . . . .	2	First stronger.
Azusa . . . . .	A. P. Griffith . . . . .	1	As if house had been struck by heavy blow.
Toluca . . . . .	W. C. Meddington . . . . .	2	
Redding . . . . .	L. F. Bassett . . . . .	1	
Colusa . . . . .	F. Roche . . . . .	More than 1	Shock would die out, only to return again.
Meridian . . . . .	T. J. Taylor . . . . .	2	Second stronger.
Marysville . . . . .	R. F. Watson . . . . .	2	First lasted about 45 s.; the second about 90.
Rumsey . . . . .	J. M. Morrin . . . . .	2	Second stronger.
Guinda . . . . .	J. Jacobsen . . . . .	1	Continuous shake.
Capay . . . . .	S. Schwale . . . . .	1	Continuous shake.
Woodland . . . . .	I. A. Morris . . . . .	2	First stronger.
Plainfield . . . . .	H. O. Purington . . . . .	2	First stronger.
Black's Station . . . . .	S. P. Cutler . . . . .	2	First stronger.
Knight's Landing . . . . .	L. T. Shamp . . . . .	2	First stronger.
Sacramento . . . . .	J. A. Marshal . . . . .	2	Oscillation ended in 2 jars, with appreciable time between.
Fairoaks . . . . .	L. M. Shelton . . . . .	1	One straight shakej very light.
Main Prairie . . . . .	Mrs. A. Rattike . . . . .	1	
Binghamton . . . . .	W. H. Smith . . . . .	2	Second stronger.
Collinsville . . . . .	J. Antonini . . . . .	4	Second stronger.
Ione . . . . .	J. F. Scott . . . . .	2	Second stronger.
Stockton . . . . .	E. P. Higby . . . . .	2	Of equal strength; interval of a few seconds.
Oakdale . . . . .	E. C. Crawford . . . . .	3	Second stronger.
Turlock . . . . .	J. L. Brown . . . . .	1	
Westley . . . . .	W. G. Carey . . . . .	2	Second stronger.
Merced . . . . .	F. J. Reidy . . . . .	2	Second stronger.
Madera . . . . .	F. E. Smith . . . . .	2	30 s. and 60 s.; second stronger.
Fresno . . . . .	J. P. Bolton . . . . .	2	First stronger.
Jameson . . . . .	W. J. Williams . . . . .	2	
Kingsbury . . . . .	A. B. Loomis . . . . .	1	
Riverdale . . . . .	W. Lenson . . . . .	2	Second stronger.
Visalia . . . . .	A. M. Doty . . . . .	4	Last most pronounced.
Exter . . . . .	H. R. Stephens . . . . .	2	Nearly equal in intensity.
Bakersfield . . . . .	A. G. Grant . . . . .	1	10 seconds.
MeArthur . . . . .	J. MeArthur . . . . .	2	First stronger.
Susanville . . . . .	J. Branham . . . . .	1	Probably 2 s-
Quincy . . . . .	L. A. Barrett . . . . .	1	
Kittle . . . . .	F. Campbell . . . . .	1	
Beckwith . . . . .	J. W. Middletoa . . . . .	2	Not sure; there was a wavelike motion, with a sudden jar at the end.
Boca . . . . .	A. E. Daswell . . . . .	1	60 s.
Stirling City . . . . .	H. B. Weaver . . . . .	1	
Paradise . . . . .	F. W. Day . . . . .	2	Second stronger.
Allegheny . . . . .	W. A. Clayton . . . . .	2	
Pino Grande . . . . .	W. E. Ba.sham . . . . .	1	
Nashville . . . . .	J. C. Hcald . . . . .	1	
West Point . . . . .	J. A. Wilson . . . . .	1	
Railroad Flat . . . . .	E. Taylor . . . . .	1	
Milton . . . . .	J. H. Southwick . . . . .	2	Second stronger.
Tuolumne . . . . .	J. T. Thompson . . . . .	2	
do . . . . .	J. E. Coover . . . . .	1	
LaGrange . . . . .	J. A. Hammond . . . . .	2	Second stronger.
Sequoia . . . . .	M. Crocker . . . . .	2	2 proJott^ed light sbocks.
Darrah . . . . .	R. Darrah . . . . .	2	Second stronger.
Fresno Flats . . . . .	Postmaster . . . . .	1	
Gold . . . . .	T. J. Rhodes . . . . .	2	Both about <i>the</i> same; quite heavy.
Magnet . . . . .	?	1	
Mono Lake . . . . .	E. A. Bvnediet . . . . .	2	First stronger.
Law3 . . . . .	G. D. Louderb&ek . . . . .	2	First gentle rocking; jsecond small jerks.
Lone Pine . . . . .	do . . . . .	2	A few seconds apart.
do . . . . .	G. F. Marsh . . . . .	2	First stronger.

## SOUNDS CONNECTED WITH THE EARTHQUAKE.

An interesting manifestation of the earthquake was the sound which was heard by many people in connection with the shock. Appended is a tabulated statement of the testimony bearing upon this phenomenon, if it may be so called. In this tabulation there are recorded 81 observations of people who heard sounds, without segregating those which are reported in a summary way as the common experience of "some," "several," or "many" persons. Of those, 40 report having heard sounds before having felt the shock; 14 report the sound as accompanying the shock or coincident with it; 3 heard a sound after the shock; and 19 report having heard unusual sounds at the time of the earthquake, without further specification. Besides this, there are 3 reports of sounds having preceded after-shocks, one case where the sound was observed to precede the second phase of the shock but not the first, and one case where sound was heard but no shock was felt. The observations are fairly well distributed over the region affected by the shock. Besides these observations of a positive kind, there were many cases reported where no sound was heard, altho the people were awake.

In view of the 40 positive and independent observations of sounds having preceded the shock, with, in some instances, specific evidence of actions induced by the sound having been engaged in during the interval between first hearing the sound and feeling the shock, there can be little question that sound vibrations of the air actually preceded the sensible shock. The testimony of the 14 persons who heard the sound during the shock does not contravene that of the 40 who heard it before, nor does that of the 19 persons who do not particularly specify the time relation of the sound to the shock. Sounds heard before the shock may well have continued thru the shock and come to the attention of less alert people only when the shock was felt. The three observations of sounds preceding the after-shocks are corroborative of the 40 referring to the main shock. The one case near Alturas, where men in camp heard a sound but felt no shock, is an interesting and exceptional, but credible, one.

The evidence as to the character of the sounds is consistent and uniform. They were vibrations low in the scale. This fact suggests an explanation of the failure of certain people to hear the sounds when others in the same vicinity observed them. It may be that the vibrations in question are below the range of audibility of some people and within that of others. With this question in mind, an inquiry was addressed to Prof. G. M. Stratton of Johns Hopkins University, in regard to the limit of sound. His reply was as follows:

The lowest limit of sound is so differently given by different investigators that it seems clear that individual differences play an important part. The limit is placed all the way from 8 to 30 double vibrations a second, and that may represent the range of personal variation; but more probably it varies between 16 and 30; and those who think they hear as low as 8 are in reality hearing the second partial of that tone, viz., 10 d.v. This, of course, applies only to the perception of tone; for of repeated shocks at a very low rate we can still hear the separate shocks, *e.g.*, puffs or blows, but they do not as yet fuse into a continuous tone.

Now if it should be a fact that the rumbling sounds which preceded the shock fall within the range of from 16 to 30 double vibrations per second, then from the probability set forth by Professor Stratton, the auditory organs of some people would be sensitive to such vibrations, while those of others would not.

<sup>1</sup> Professor Stratton refers to a chapter on "Tiefen! Tiefste. Tiefe," in Helmholtz's *Lehre von der Tonempfindungen*, where the difficulties of accurate determination and the different things that appear in such tones are well set forth.



Another interesting question to which the testimony gives rise is: How do such vibrations reach any locality in advance of the shock? The seismic waves traverse the earth's crust very much more swiftly than sound-waves do the air, so that it is a physical impossibility for sound-waves generated in the air above the seat of disturbance to outreach them. The vibrations observed as sounds must, therefore, be transmitted to the atmosphere by tremors of the ground which precede the larger waves, and which are not otherwise perceptible to the senses ordinarily. These doubtless correspond to those phases of seismic movements which are recorded by delicate instruments and are known as "preliminary tremors."

*Noises heard at the time of the shock.*

Locality.	Reporter.	Observer.	Kind, direction, time of noise, etc.
Ferndale.....	A. W. Blackburn	Same.....	Accompanying the quake was a rumbling, roaring sound.
Covelo.....	E. S. Larsen	Large proportion of residents	Roar just preceding earthquake shock.
Fort Bragg.....	O. F. Barth	A man.....	The wave traveled SW. and a roar accompanied it.
Mendocino.....	Wm. Mullen	Same.....	Unusual rumbling sound like distant thunder, preceding shake, being loudest at commencement of disturbance.
Albion.....	J. Coyle	Same.....	Roaring noise like heavy fall of hail coming from ocean to the west.
Point Arena.....	W. W. Fairbanks	Not named.....	Heavy roaring sound preceded the shock.
Point Arena Light-house.....	do.....	Keeper.....	Blow came quick and heavy, accompanied by heavy report.
Upper Lake.....	C. M. Hammond	do.....	A roaring noise past off to SW.
do.....	do.....	Workmen.....	A noise in the trees as tho heavy wind were blowing thru them; then the rumbling past off to SW.
Cloverdale.....	M. C. Bale	Many persons	Rumblings before the shock.
Healdsburg.....	H. R. Ball	Same.....	Attended by great rumbling noise, as thunder.
Santa Rosa.....	Miss F. Locke..	R. Worthington..	Heard roaring.
do.....	do.....	Mr. Campbell	Heard a great roaring 2 s. or 3 s. before the shock.
do.....	do.....	Watchman.....	Heard noise in SW.; then felt breeze; then felt shock.
do.....	do.....	Mrs. Lloyd.....	Heard noise; ran to window and opened it; then shock came.
do.....	do.....	A man.....	Heard roaring and saw wave of earth 2 feet high.
Cotati.....	C. L. Jeffrey	Same.....	Sound as of a strong wind before shock.
Tomales.....	do.....	A boy.....	Heard roaring and said, "Oh, there's thunder," before the shock.
do.....	do.....	A farmer.....	Heard roar from SW.
do.....	do.....	Mr. Goudy.....	Heard a great roaring sound from SE.
Point Reyes Station.....	do.....	A farmer.....	Heard roar, then felt wind on my face.
Olema.....	do.....	A dairyman.....	Heard noise in the ground, got up, then felt shock.
Bolinas.....	K. Easton.....	Same.....	Rumbling noise preceded one after-shock on April 18,
Calistoga.....	Dan Patten.....	Same.....	A rushing noise before shock came.
Napa.....	T. Hull.....	Not named.....	A rumbling, then came yhock.
Alturas.....	C. B. Towle.....	Sonic men in camp	Heard low sound of earthquake, but did not feel shock.
Redding.....	L. F. Basset.....	Same.....	Noise resembled a passing train; it preceded and outlasted the shock.
Chico.....	E. Mayhew.....	Same.....	Rumbling sound thruout the disturbance like heavy-laden wagon passing house.
Willows.....	A. W. Sehorn.....	Same.....	Unusual rumbling sound preceded shock, gradually grew louder, and died away with the shaking.
Colusa.....	Fred Roche.....	Same.....	Sound like an approaching train coincided with shock.
Berkeley.....	Miss F. Locke...	Capt. Fire Dept...	Was awakened by roar 5 s. before shock.
San Franriseo...	M. C. Erskine...	Same.....	Awake at 5 <sup>h</sup> 10 <sup>m</sup> A.M. Heard a great roaring from NE.; soon the shock came from same direction.

*Noises heard at the time of the shock. — Continued.*

Locality.	Reporter.	Observer.	Kind, direction, time of noise, etc.
San Francisco	T. J. J. See . . . . .	Lieut. Bertholf and other officers	A low rumbling preceded earthquake.
Peninsula of San Francisco . . . . .	R. Anderson	Many persons	Noise accompanying the shock; indescribable noise associated with main shock; immediately after the shock.
San Mateo . . . . .	B. A. Peckham..	Mr. Maxwell. . . . .	Heavy rumbling which he took for thunder, from NW., before shock.
San Jose . . . . .	Mr. Connell . . . . .	Same. . . . .	An undertone, rumbling sound coincided with beginning of shock.
do. . . . .	W. S. Prosser . . . . .	Several good observers outdoors	The noise of the quake came from SE. and died away toward San Francisco.
Santa Clara . . . . . (3 mi. west)	I. H. Snyder....	D. Pickering . . . . .	Sound compared to stampede of cattle.
Congress Springs	J. C. Branner....	Residents. . . . .	Shock accompanied by rumbling; after-shocks preceded by sound like a blast.
Los Gatos . . . . .	L. H. Snyder	Mr. Land. . . . .	Premonitory roar came from south.
do. . . . .	W. S. T. Smith..	Same. . . . .	No sound heard for main shock, but muffled sound heard just before each minor shock.
do. . . . .	F. H. McCullogh	Same. . . . .	Sound as of bad storm coincident with first and worst of shock. Later in the day there was a rumbling sound to me (deaf) not unlike a distant detonation.
Wright, 4 miles south of . . . . .	L. E. Davidson..	Same. . . . .	Attention first drawn to a slight rumbling noise.
Glenwood . . . . .	Miss F. Locke...	Different persons	After every shock on April 18 was a rumble like that of artillery.
Scott Valley (Santa Cruz County)	do. . . . .	Mrs. Field . . . . .	Tremendous roaring in NE.
Santa Cruz . . . . .	G. A. Waring	Wharfinger . . . . .	Rumble before shock.
Santa Cruz Light-house . . . . .	do. . . . .	Keeper	Noise as of a wagon crossing a bridge preceded every quake.
Wilder's Dairy N. W. of Santa Cruz . . . . .	do. . . . .	Not named . . . . .	Shock preceded by rumbling from south.
Swanton . . . . .	do. . . . .	do. . . . .	Distinct noise as of team crossing a bridge to NW. preceded every shock.
Ano Nuevo Light-house . . . . .	do. . . . .	Keeper	Distinct rumbling preceded shock.
Pescadero . . . . .	do. . . . .	Some people....	Noise as of wind preceded the shock.
Castroville . . . . .	do. . . . .	Not named . . . . .	Shock described as beginning like a, subterranean blast.
Salinas . . . . .	Bertha M. Abbott	Same. . . . .	Rumbling noise coincided with shock.
San Lucas	G. A. Waring	Not named . . . . .	Sound reported to have been heard.
Fort Romie . . . . .	do. . . . .	Not named . . . . .	Noise heard after shock.
San Luis Obispo, 1 mile east of..	do. . . . .	do. . . . .	Great roar heard.
New Almaden (Hacienda) . . . . .	do. . . . .	Not named . . . . .	Loud noise like thunder traveled northward, distinctly preceding shock.
Coyote . . . . .	do. . . . .	A man. . . . .	Noise from SE. seemed to pass over him.
San Martin . . . . .	do. . . . .	A man . . . . .	Heard roar, horse became frightened before shock came.
Gilroy to Hollister	do. . . . .	Various persons..	Rumble heard all thru region from Old Gilroy and San Filipe to Hollister. One said from SE., another from SW.
Tres Pinos . . . . .	do. . . . .	Not named . . . . .	Distinct rumble preceded shock at Palm-tag's winery.
Bell's Station	G. F. Zofftnan...	do. . . . .	Rumble distinctly heard before the shock.
Paicnes . . . . .	G. A. Waring	do. . . . .	Distinct noise preceded shock at Cienega Lime Kilns.
Hernandez . . . . .	do. . . . .	do. . . . .	No noise before quake, but report as of blast immediately preceded second (hardest) period of vibration.
Mt. Hamilton . . . . .	K. Burns.....	Same. . . . .	Sound as of flight of birds simultaneous with shock.
Calaveras Valley	G. F. Zoffnuin..	R. Ingleson.....	The two separate shocks accompanied by roaring sound from north.
Modesto . . . . .	E. Hughes . . . . .	Several persons . . . . .	Roaring or rumbling sound beginning & few seconds before and continuing until end of disturbance.
do. . . . .	do. . . . .	(Green Bros. . . . .	Roaring sound just before shock.
do. . . . .	do. . . . .	Mr. Elsey. . . . .	Rumbling sound.

*Noises heard at the time of the shock—Continued.*

Locality.	Reporter.	Observer.	Kind, direction, time of noise, etc.
Modesto . . . . .	E. Hughes ..	A. H. Holtman ..	Shock preceded by roaring sound.
do . . . . .	do . . . . .	H. Hintze . . . . .	Rumbling sound.
Stockton . . . . .	do . . . . .	Some persons out of doors . . . . .	Dull rumbling sound just preceding shock; some think it emanated from buildings.
Westley . . . . .	W. G. Carey	Men sleeping on scow on river..	Heard terrible rumbling 30 s. before shock; came out of scow to see what it was, then shock came.
Conejo . . . . .	E. Picket__	Same . . . . .	Awakened by noise like locomotive coming at full speed.
Santa Barbara	J. A. Dodge.	Neighbors . . . . .	Rumbling just before shock.
Lone Pine, Ne- vada . . . . .	G. F. Marsh.	Same . . . . .	Slight rumbling sound like wind blowing.
Ballarat, Inj <sup>o</sup> County . . . . .	D. C. Pickett	Same . . . . .	Awake and up. First indication of earthquake was low, distant, and increasing roar.

## VISIBLE UNDULATIONS OF THE GROUND.

The earth-waves generated at the fault past thru the earth's crust with a velocity of probably from 2 to 3 kilometers per second. The undulations of the surface due to the passage of such waves would be so swift that they would scarcely be observed visually. Yet there is considerable testimony, of a consistent and independent character, that much slower undulations were observed. This testimony comes from various parts of the region disturbed, and a great deal of it is positive and unequivocal as to what seemed to be the fact. The evidence indicates that there is a type of wave in the ground, in the region of high intensity, which has not yet been sufficiently recognized, and the origin of which is obscure. Some 20 or more observations bearing upon this class of phenomena are here summarily recorded:

Judging from the descriptions given, these waves behaved like undulations in water, with an oscillation approximately normal to the surface. They were for the most part observed on alluvial tracts, but some of the reports come from districts where there is but a thin veneer of alluvium or soil upon the rocks. If it should prove, on the basis of more abundant evidence, that these waves are peculiar to alluviated basins, they may be explained as reflections from the rocky slopes of such basins. If a bowl of liquid be tapt smartly, vibrations are inaugurated in the rigid bowl which have a speed so great that the secondary waves generated in the liquid pass out from all parts of the walls of the vessel sensibly at the same instant. But the secondary waves thus generated in the liquid have so slow a rate of propagation that they are quite apparent to the eye, and in the central part of the surface of the liquid, when the waves meet, there is a violent commotion. If, instead of a bowl of liquid, we have a rock basin filled with water-saturated alluvium, it seems probable that a similar effect would be produced in a modified degree; and the visible waves at the surface may have had such an origin. But whatever be their origin, it is apparent that they must be a large factor in damaging structures situated upon the ground in which they occur, and so raising the apparent intensity on any scale based on destructive! effects.

*Freshwater, Humboldt County* (S. E. Shinn).—My orchard raised up between 2 and 3 feet like a big breaker coming in.

*Ferndale, Humboldt County* (A. W. Blackburn).—Those who claim to have been out of doors when the shock came, state that the earth rose and fell like the waves of the sea.

*Fort Bragg, Myndocino County* (O. F. Bartli).—A man walking along the street was thrown down. He is positive the wave traveled southwest. The ground undulations wore 2 and 3 feet high.

*Point Arena, Mendocino County* (W.W.Fairbanks).—The ground moved in undulating swells or waves, rising and falling.

*Santa Rosa, Sonoma County* (Miss Locke). — A man saw an earth-wave 2 feet high.  
*Cotati, Sonoma County* (C. L. Jeffrey). — The surface of the earth waved like water.

*Napa, Napa County* (T. Hull). — Those who were out of doors say the trees bent as the shock came like a wave of the ocean.

*Pleasanton, Alameda County* (Miss F. Locke). — A lady near Pleasanton saw the earth go in waves like the ocean.

*San Francisco* (Miss F. Locke). — A fireman at the engine house 1757 Waller Street said the ground went in waves.

*San Mateo, San Mateo County* (Mr. Maxwell). — The earth rose and fell like the swell of the sea, the swells being about 3 feet high.

*Saratoga, Santa Clara County* (Louise M. Atkinson). — Distinct waves past over the ground from northwest to southeast, the orchard trees rising and falling on each wave, like ships at sea, while the electric poles along the road leaned this way and that, some seeming almost to touch the ground.

*Santa Clara, Santa Clara County* (I. H. Snyder). — Mr. Dan Pickering, living a mile south of Santa Clara, says that the ground rose and fell in waves about a foot high. Others say that the orchards seemed to be agitated by a wave-like motion.

*San Jose, Santa Clara County* (W. S. Prosser). — Many persons saw waves in the ground. Sifting out exaggerations, these appeared to be rather more than a foot in height. The best observer estimated the distance from crest to crest, at 60 feet; others much less, but they must have been greater, for there is no evidence which shows any such vertical cracks as would have been produced by short waves. A good observer 6 miles southwest of San Jose described the waves as parallel with certain tree rows which are northeast and southwest; and the waves moved from him at right angles to the line toward San Francisco. Another person, 6 miles northwest from San Jose and looking south, saw the waves (which he thinks were east and west) coming toward him, and hence toward San Francisco; but about the middle of the quake these were met by other waves and the whole surface resembled hillocks or cross seas, and the tree-tops waved wildly. To the man to the southwest of San Jose, however, the tops of the trees were almost still, while the trunks waved sinuously.

*Meridian, Santa Clara County* (G. A. Waring). — A lady reports seeing waves traveling southward along the driveway, and a man reports seeing a heavy wagon move back and forth several times, 4 or 5 feet along the driveway.

*Campbell, Santa Clara County* (F. M. Righter). — People out of doors at the time state that there was a very rapid wave-like motion of the surface of the earth.

*Wright, Santa Clara County* (Flora E. Beecher). — Mr. Deacon, our neighbor, rose and stood by the window, and he declares that the ground rose in waves.

*Coyote, Santa Clara Comity* (G. A. Waring). — Near Coyote a man reports having seen a northwest-southeast fence move in a wave-like motion, beginning at southern end.

*Paicenes, San Benito County* (G. A. Waring). — Toward the Cienega Lime Kilns, 4 miles south of Paicenes, a man reports seeing a wave coming westward thru a grain field.

*San Lucas, Monterey County* (G. A. Waring). — West of San Lucas the waves were reported to have been seen moving southward over the hills.

*San Luis Runrh, near Paeheco Pass* (G. F. Zoffman). — Mr. Mills stated that the surface of the ground moved up and down like the waves of the ocean.

*Mendota, Fresno County* (G. F. Zoffman). — The\* people who observed the plains at Mendota said that they assumed a wave-like appearance, and that the trains rose and fell as the undulations past beneath the tracks. They also stated that this wave-like appearance was confined to the north and south movement,, the east and west motion being more in the nature of a tremor.

*Visalia, Tulanc County* (F. A. Swanger). — The movement of swell and fall of wave seemed strong.

## PATHOGENIC EFFECTS OF THE EARTHQUAKE.

A curious and fortunately trivial effect of the earthquake was the production of nausea. This was observed especially in the region of slower motion of the earth, beyond the zone of destructive effects, but one or two cases being reported from the region of high intensity. The sickness produced was in most cases apparently similar to seasickness, and ascribable to the swaying of the ground. In the few cases which occurred in the region of quick motion, the nausea was more probably due to nervous shock. Brief mention is here made of the cases reported, tho there were probably many others.

At Ruby, in Siskiyou County (R. E. Madden), intensity III—II, persons were slightly nauseated or rendered dizzy, but the feeling past instantly. At Upton, Siskiyou County (E. R. Dixon), intensity IV-III, people felt seasick. Mr. J. H. Roberts, of Yuba City, intensity VI-V, reports that 5 persons on his place were made quite sick. In Marysville (R. F. Watson) the shock caused a dizzy feeling. At Stockton (E. Hughes), intensity VI, a considerable number of people suffered from nausea and dizziness, with headache, for a time after the shock. With some these disagreeable symptoms persisted all the following day. At Modesto (E. Hughes), intensity VI, a number of people were affected by symptoms somewhat like those of seasickness for several hours after the shock. San Francisco (Miss F. Locke). Mrs. E. was nauseated by the earthquake and felt pains in her heart. Several people were nauseated by the motion of the ground at Pescadero, San Mateo County, intensity VIII-VII. (G. A. Waring.)

In Bear Valley, San Benito County (G. A. Waring), intensity VI-V, a man out-of-doors became dizzy and nauseated, but did not at the time realize the cause. Thru the south end of the valley several people became dizzy. Between Mendota and Coalinga (G. F. Zoffman), intensity VII-VI, many persons suffered from a nauseating sensation. At Conejo, Fresno County (E. Pickett), intensity VI, the earthquake made some people sick at the stomach. At Santa Barbara (J. A. Dodge), intensity III, a woman who was out-of-doors at the time of the shock was made slightly dizzy. In Gardnerville, Nevada (J. A. Reid), intensity IV, a number of people complained of a feeling of nausea while eating breakfast at the time of the earthquake, but they felt no motion. At Yerington, Nevada (G. D. Louderback), intensity IV-III, one person experienced a dizzy sensation. At Lone Pine, Nevada (M. S. Dearborn), intensity IV, a good many people when they first felt the shock thought that they were simply dizzy.

## EFFECT OF THE EARTHQUAKE ON ANIMALS.

Miss Mnette Locke, of Santa Cruz, has interested herself in an inquiry into the behavior of animals at the time of the earthquake, and has prepared lengthy notes reciting incidents which were reported to her as the effect of the main shock and the after-shocks upon animals in various parts of the Coast Ranges extending from Santa Rosa to Santa Cruz. Her notes, which refer chiefly to domesticated animals, form the basis for the following summary statement:

*Horses.* — Horses whinnied or snorted before the shock and stampeded when the latter was felt, some falling owing to the commotion of the ground. Horses in harness became frightened and ran away, while others stopt and screamed. Some horses with riders in the saddle stumbled and fell; others stood and shivered. A mule near Santa Rosa refused to eat all day. A farmer in the same neighborhood observed his horses moving about, whinnying and snorting, and called to his boy, who was with them, inquiring what was the matter, but before the boy could answer he felt the shock. In a stable of 30 horses on Alabama Street, San Francisco, all reared, snorted and jumped before

the stable-man, who had just fed them, knew the cause of the trouble. Of the 30, all but 5 broke their halters and came toward the stable-man, who had to keep them off with a pitchfork. Several horses at the various engine houses of the San Francisco Fire Department became frightened and broke away from their stalls. In stables generally horses broke away from their stalls, and some failing to break loose lay down.

*Cattle.* — Cattle on the hills came down to lower levels, and in some localities did not return to the hills for some days after the shock. Cows in corrals near the fault-line were in many localities thrown to the ground; others stampeded and ran about wildly. At Olema cows in the milking corral were thrown to the ground and rolled over, and as soon as they could stand they stampeded. The stampeding of cows from the milking corral was reported at many ranches. Several instances were reported where cows stampeded before the shock was felt by the observer. In other cases cows about to be milked are said to have been restless before the shock and to have lain down as soon as the shock was felt, some giving less milk than usual. Two cows near Duncan's Mills are said to have died as a result of the shock. Several cows dropt calves prematurely. Lowing and bellowing of the cattle at the time of the shock was very commonly reported, and in some cases this is said to have occurred a little before the shock.

*Cats.* — Various reports regarding the behavior of cats at the time of the earthquake and the after-shocks indicate that they became alarmed. Some rushed about wildly, with big tails and bristling backs; some hid in dark corners and otherwise behaved abnormally; some disappeared for several days after the shock. In the after-shocks, cats seemed to perceive the tremor before people did, and crouched in fright or ran. At Olema 7 cats were not seen for 2 days after the shock, and in Alameda some cats disappeared for 3 days. Some carried off their kittens.

*Dogs.* — Dogs generally became alert before the after-shocks, and barked, whined, or ran to cover. After the shock some ran away and did not return for a day or several days. Some barked at the time of the shock and ran about with their tails between their legs. Many sought the protection of houses and stayed close to people after the shock. One dog near Santa Rosa ran about the house for 10 seconds before the shock was felt, and then jumped out of an open window down one story to the ground. Some dogs were in an excited condition, running about vaguely for some time after the shock; and this was repeated at the after-shocks. Others ran straight away at full speed. Some bitches brought their puppies to what apparently seemed to them safer quarters. Some took to their beds for several days after the shock and others refused to eat. The most common report regarding the behavior of dogs was their howling during the night preceding the earthquake.

*Chickens.*—Chickens generally ran for shelter to their houses, with their wings outstretched, squawking.

*Wild animals in confinement.* — The wild animals in confinement at the Chutes, San Francisco, crouched and remained quiet during the shock, but roared after it was over, led by the elephant. The elephant also roared at the times of the after-shocks.

## MINOR GEOLOGICAL EFFECTS OF THE EARTHQUAKE.

---

### LANDSLIDES.

There are three types of landslides known in the Coast Ranges. For convenience in reference they may be designated as earth-avalanches, earth-slumps, and earth-flows. The first and last of these are of somewhat exceptional occurrence, but the second is exceedingly common. These landslides are of geological importance to an agency concerned in the evolution of the geomorphy of the Coast Ranges of California to an extent equaled in few other regions; and it becomes a matter of interest to appreciate the rôle played by earthquakes in promoting the efficiency of this agency. The activity of all three kinds of landslides is related directly or indirectly to the earthquake of April 18, 1906. In order to appreciate certain phases of the relationship, it will be of advantage to state briefly, in a general way, some of the characteristics of these different types of landslides. In doing this, reference will first be made to the most commonly occurring type, the earth-slump. The other two may then be characterized by contrast with this type.

Under normal conditions, earth-slumps appear chiefly as features of mature slopes which are in adjustment to the ordinary processes of rain erosion. They are also found, however, as notable features of immature slopes, at the base of which horizontal corrasion is active, as on sea-cliffs and stream-cliffs, supplanting under certain conditions the earth-avalanche which is chiefly found in such situations. On the mature slopes of the Coast Ranges of California, under present climatic conditions, the regolith or mantle of decomposed rock, on the more common rocks, appears to be accumulating at a somewhat faster rate than the rain-wash can remove it. This excessive accumulation of the regolith appears to be an important factor in producing conditions conducive to earth-slumps. The climate of the region is characterized by a pronounced alternation of dry and wet seasons. In the summer the soil and regolith on the hillsides are dried out to a considerable depth, in many cases down to the underlying firm rock; and as the desiccation proceeds the soil shrinks and cracks. The cracks thus formed permit the ready access of the early winter rains to the deeper portions of the soil and regolith. The concentration of the entire rainfall in one half of the year is also more conducive to the saturation of the ground than if it were distributed thruout the year. The climate is thus a contributory factor to the prevalence of earth-slumps.

A factor of local importance is the character of the underlying geological formations. Where these consist of clays or shales, earth-slumps are much more liable to be inaugurated and to recur than where the rocks have little or no clay in them. The emergence of springs on hillsides is also a fruitful cause of earth-slumping where other conditions, particularly the last mentioned, are favorable. Another factor may be the recent subjection of the hill-slopes to grazing and tillage. In general, however, this interference with natural conditions appears to have been conducive to excessive corrasion and sapping, rather than to slumping. Grazing and tillage rob the surface of its natural protection of dead grass and other vegetation, which in the early winter season tend to restrain the rapid flow of the rain-water and its concentration in lines of corrasive activity. New lines of corrasion are thus inaugurated, and where the rocks are but slightly coherent

new geomorphic forms, of the bad-land type, are evolved with startling rapidity. This corrosive process is sometimes complicated by earth-slumping.

The activity of earth-slumping as a degradational process is, in general, a function of the amount of rainfall in any given season. Thus in the winter of 1889-1890, in which the rainfall was exceptionally heavy, earth-slumps thruout the Coast Ranges were much more active than in seasons of normal rainfall, and many new ones were started. In all such earth-slumps the saturation with water of the soil and regolith, and in some cases of the underlying formations, is an essential condition. This water is the main agent in loosening or disintegrating the material preparatory to the slip. It is also a motive power on account of the large addition which it makes to the weight of the unstable mass; and it is a transporting agent owing to the fluid or plastic nature which it imparts to it.

The character of the movement in an earth-slump is noteworthy. The ground moved drops away from the slope in the form of a bite, leaving a lunate or horseshoe-shaped scarp overlooking the sunken area. As the mass moves down, it generally encounters the resistance of more stable portions of the slope below, and is thus crowded upon itself. The plastic mass is in this way deformed, and the deformation amounts in many cases to an effective rotation of the moved portion upon a horizontal axis. The lower portion is thrust over the passive ground at its lower margin, and the slope of the surface of the moved part is greatly diminished and in many cases reversed. Between the reversed slope and the limiting scarp a depression is thus formed which may become a pool. The change in the slope thus occasioned gives rise to the landslide terrace.<sup>1</sup> This kind of movement may be slowly continuous for considerable periods, or it may be fitful, depending upon the supply of water. In a slumping tract the movement may be repeated at various levels, giving the slope an irregularly stepped or terraced profile; and if the movement has been recent, numerous cracks and fissures traverse these terraces, particularly where they break away from the upper limiting scarp.

The instability of the mass is an essential feature of the earth-slump. When not actually moving, its movement is imminent at all times, but with varying degrees of imminence, depending upon local conditions. This instability and imminence of movement is true of many slopes where no actual earth-slump has appeared, but where movement may be inaugurated at any time by an exceptionally heavy winter or by some other precipitating cause. Severe earthquakes constitute one of these precipitatory causes. Thruout the Coast Ranges of California the small residual stability of many earth-slumps was overcome by the vibration of the ground at the time of the earthquake of April 18, and they were caused to slump forward. In many other instances new earth-slumps were started, owing to the same general cause. Besides the earth-slump movements which were the immediate effect of the earthquake shock, there were doubtless others which were indirectly referable to the same cause. As will be shown in another part of this report, one effect of the earthquake was the derangement of the normal movement and amount of flow of underground waters, the general result being a temporary increase of flow. Inasmuch as many earth-slumps depend for their water upon springs, there can be little doubt that the increased flow had its effect upon these, and promoted their activity several days or possibly weeks after the shock itself.

Another way in which the shock conduced to the activity of earth-slumps at a later date than the shock itself was by opening cracks and thus rendering the deeper {Millions of the unstable mass more accessible to the rains of the following winter. The movement of earth-slumps at the time of the earthquake was abnormally large and sudden, thus leading to the development of numerous open cracks, not only in the landslide proper, but also in the surrounding slopes above the limiting scarp. The effect of this

<sup>1</sup>See U. S. G. S. Monograph, I, Lake Bonneville, by G. K. Gilbert, p. 53.



would inevitably be the enlargement of the area of the slide in the wet season. Similarly on many slopes, particularly at points not far distant from the Rift, numerous cracks were opened without actual slumping of the ground occurring in consequence of the shock; but the conditions were thus provided for the slumping process the following winter. During the winter 1906-1907 many such slides were reported in a general way. Unfortunately detailed information as to their occurrence is as yet lacking. It is to be noted that an exceptionally heavy rainfall conspired with the conditions established by the earthquake to produce these landslides.

In the type of landslide thus far considered, the contained water, which is at once in part the cause and the means of the movement, accumulates relatively slowly, and it varies with the season, there being usually a more or less free drainage from the lower portion of such slides. There are, however, other landslides which are due to a relatively large and sudden accession of water to the unconsolidated materials of a slope. Such sudden accessions of water may be conceived to be produced in a variety of ways; such, for example, as a so-called "cloudburst" in a desert canyon, the slopes of which may be heavily mantled by earth and loose rock; or the breaking of a barrier which retains a bog or other body of water. For the present purpose, however, which is not that of an exhaustive systematic discussion of this class of phenomena, it will be sufficient to take note only of water which is expelled from the ground by the compressive action of the earthquake shock. Such landslides may be discriminated from earth-slumps by reason of their greater mobility, under the designation *earth-flow*. Earth-flows differ from earth-slumps not only in the much larger quantity of water involved in their mechanism as a moving mass, in the suddenness with which the water becomes efficient as a transporting agency, and in the rapidity of the movement; but also in the brevity of the entire process, its finality, and its non-recurrence.

Besides these two types of landslides, there is still another, which is immediately associated with earthquakes as a cause of movement. This is the slide of dry earth and rock upon precipitous slopes or their fall from cliffs. Soil or other loose forms of earth may participate in such landslides, but the material is usually composed chiefly of rock which becomes increasingly shattered with the progress of the slide. Such landslides will here be referred to as *earth-avalanches*. They are distinguished from both earth-slumps and earth-flows by the character of the material and by the absence of water as an essential factor in producing movement. They also differ usually in the marked acclivity of the slopes on which they occur. They differ from earth-slumps, but resemble earth-flows, in the finality or completeness of the movement. They are not progressive movements, but sudden events; and there is no recurrence of movement of the material involved, altho the avalanche may recur at the same place.

Besides these three types of landslide, another ought perhaps to be recognized. This is the form of superficial earth movement which occurred in consequence of the earthquake shock on the alluvial bottom-lands of many streams. It may appropriately be designated an *earth-lurch*. It varies from the opening of a mere crack, with a slight movement of the ground on one or both sides, to a violent and complicated deformation of the surface, usually accompanied by cracks and open fissures parallel to the trend of the neighboring stream trench. These cracks and fissures cut the ground up into strips or prisms which lurch toward the stream trench, or, it may be, toward an abandoned slough, the lurch usually being accompanied by a rotation of the prism. They are distinguished from all other forms of landslides by occurring on perfectly flat ground and by the fact that they are apparently referable directly and solely to the horizontal jerk of the earth movement during the earthquake shock.

A brief account, which in some cases amounts only to a mention, will now be given of some of the various kinds of landslides set in motion by the earthquake.

## EARTH-AVALANCHES.

Earth-avalanches were caused chiefly along the sea-cliffs of the coast on the morning of the earthquake, tho some also occurred on steep canyons within the zone of high intensity. On the coast the earth-avalanches were for the most part simply an exceptional incident in the normal process of cliff recession. Where the upland of the Coast Ranges approaches the shore, the horizontal corrasion of the waves maintains a steep sea-cliff; and the recession of the sea-cliff is effected by the repeated occurrence of earth-avalanches due to the undermining by the sea, combined with the disintegrating action of atmospheric agencies. There are thus always upon the face of the cliff masses of earth or rock, the fall of which is imminent and may easily be precipitated by a severe shock of earthquake.

The most notable of the earth-avalanches occurred where the sea-cliffs are highest and steepest. This happens on the coast of Humboldt County, between Cape Mendocino and Point Delgada. Not only are the cliffs here particularly favorable for large earth-avalanches, but the coast here is close to the line of the fault which caused the earthquake, and so received an exceptionally severe shaking. For many miles of coast there was a general slipping of rock and earth into the sea, down very precipitous sea-cliffs ranging up to over 2,000 feet in height. Between Shelter Cove and Point Arena, the sea-cliffs are not so high nor so continuous, but there was nevertheless a very general, and locally large, shedding of material from their face; and the sea was muddy for many days after the earthquake in consequence of the dejection of the débris upon the whore, within range of the attack of the waves.

From Point Arena southward to Fort Ross, the cliffs are low, being for the most part not in excess of 100 feet. Earth-avalanches were nevertheless of common occurrence along this stretch of coast. South of Fort Ross to Bodega Head the cliffs are again, as far as the mouth of the Russian River, several hundred feet high and very steep. Here again earth-avalanches were extensive. The rocks along this entire stretch of coast from Cape Mendocino to Bodega Head are prevailingly sandstones and shales. On the sea-cliffs on the north side of Bolinas Bay and west of the town of Bolinas, there was a very general crumbling and fall of the sea-cliff upon the beach. South of the Golden Gate, the most notable earth-avalanches were along the sea-cliffs between the city and Mussel Rock. This cliff has a length of about 6 miles and ranges in height from about 100 feet up to 700 feet, and is cut almost wholly in the strata of the Merced (Pliocene) series, which are inclined at angles varying from  $15^{\circ}$  to  $75^{\circ}$ . The rocks are for the most part rather soft and incoherent, tho there are numerous well-cemented and indurated beds in the series. This cliff converges on the fault at a small angle, and intersects it at its south end near Mussel Rock. The cliff was severely shaken and great quantities of earth and rock were caused to fall or slip down. The great earth-slump at Mussel Rock (Plate 129c, D) was also notably accelerated. A similar sudden movement of the ground occurred on the west side of Merced Lake, whereby a large section of the slope sank toward and into the lake, and a portion of the bottom of the lake was lifted above the surface by the deformational rotation of the collapsed ground.

To the south of Mussel Rock there were several small earth-avalanches along the cliffs, and numerous cracks were formed near the brink of the cliffs which will in future doubtless lead to further falls from the cliff-face. Near San Pedro Point there was a large movement of the earth on the face; of the high cliff. One earth-avalanche to the north of the Devil's Slide started about 500 feet above the shore and swept the face of the cliff, carrying away several hundred feet of rock. The slick occurred near the contact of sandstones reposing on granite, and both kinds of rock were involved. Smaller earth-avalanches occurred farther south on the sea-cliffs.

Inland from the coast there were numerous earth-avalanches caused by the earthquake on the walls of steep canyons. One of the most noteworthy of these was on the north side of a short but deep canyon west of Chittenden and close to the line of the fault. (Plate 126A.) The rocks composing the side of the canyon are the bituminous shales of the Monterey series. The slope rises very steeply for about 500 feet and was quite dry before the earthquake, altho it was covered with spring vegetation. Areas of bare rock appeared thru this vegetation. At the time of the shock several earth-avalanches were started, and these slid suddenly down the slope, part of the material filling the bottom of the canyon and part remaining on the less steep lower portions of the slope. The larger masses were broken off up near the brink of the canyon. There was apparently little or no rotation of the sliding mass. The result was to gorge completely the lower part of the canyon with rock débris, to widen the upper part of the canyon, and to expose extensive surfaces of unweathered rock.

On Deer Creek, in the Santa Cruz Mountains, an extensive earth-avalanche started near Grizzly Rock and moved westward down a steep, narrow canyon for about 0.25 mile. (Plates 124D and 125A.) It then changed its course thru an angle of about 60° as it entered a wider canyon of lower grade, and following this for another 0.25 mile, finally stopt at the Hoffmann Shingle Mill, which was wrecked. A fine growth of redwood, some 200 feet in height, was mowed down, and covered to the extent of 10 acres or more with from 30 to 60 feet of débris. The trees were from 3 to 10 feet in diameter. The main canyon was filled with earth and rock for an average width of 80 yards and a length of 400 yards. The entire area of the slide was about 25 acres. The difference in altitude between the point where the slide started and the shingle mill, where it stopt, is 500 feet. According to Mr. G. A. Waring, the slide material has a depth of 300 feet and is composed of soil, clay, and shale. Mr. E. P. Carey, who examined and photographed this interesting earth-avalanche, states that it originated in rock that broke away in pieces from the steeply inclined slope at the head of the gulch, leaving a large theater-like space, the bare, light-colored rock walls of which were in sharp contrast with the surrounding green vegetation. The movement was faster in the center or deepest part of the gorge than on the margins. The rock was in general piled up higher along both sides than in the center, and many pieces became entangled in the standing or uprooted trees. A steep-walled tributary to the southeast of the main gulch supplied rock material to the main avalanche, and the 2 streams joined much as confluent glaciers do. The material involved in the avalanche showed every gradation from powder to angular pieces 30 feet or more in diameter. The surface was uneven thruout. Near the mill a man was killed by a tree that fell as the avalanche was advancing.

Mr. Carey also reports another earth-avalanche located on the Petty ranch, about 4 miles southeast of the one just described. Here a huge rock mass, which embraces an area of about 12 acres at the headwaters of Cauley Gulch, broke away from a ledge and dropt, leaving a vertical scarp of 40 feet or more. The rock mass in this case was not shattered. It practically maintained its integrity. The narrow gulch below was unfavorable for free downward movement. As the block readjusted itself, its upper surface became nearly level, but was lower at the foot of the scarp than at its outer edge, thus indicating that it had suffered rotation.

At a point about 1.25 miles west of the Mindego sink, on the ranch of Andrew Stengel, an earth-avalanche is reported by Mr. Albert C. Herre. It is on a small tributary of Alpine Creek, and about 4 miles southwest of the San Andreas fault at the point where the latter crosses Black Mountain into the head of Stevens Creek Canyon. The creek here is in a narrow, steep-walled canyon in the bituminous shale of the Monterey series. The soil on the canyon side was very shallow, and at the time of the earthquake it was shaken down into the bottom of the canyon, leaving the walls absolutely bare in places



A. Maaoma earth-avalanche. Tuffs dipping in the direction of the slide. Slip included the crest of the ridge. E. S. H.

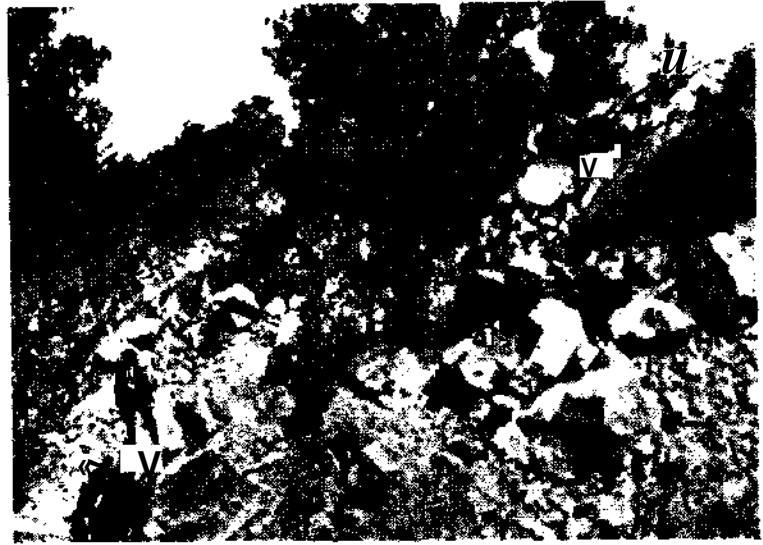

B. Maaoma earth-avalanche. A dot view. B. S. H.

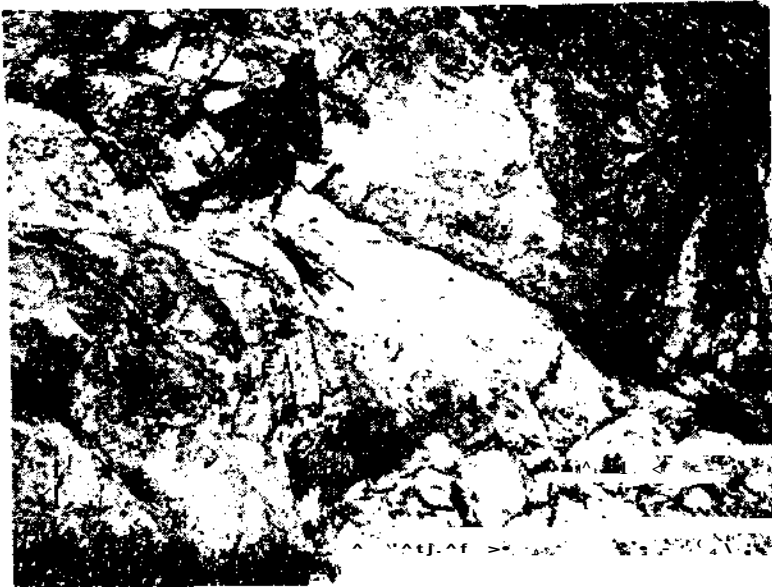

C. Earth-avalanche in granite on road near Half Moon Bay. E. D.



D. Deer Creek, Santa Grm Moantams. Earth-avalaachs from Griwlj Ptak. B. B.



A. Deer Oreet, Santa Cm Mountains. Lower end of earth-avalanche shown in Plate 124 B. E. G.



B. Scarp in the southeast quarter of section 15, township 16 south, range 12 east, near Cantua. G. D. L.

for a hundred yards at a stretch. The slide extends for 0.25 mile on both sides of the canyon. A similar earth-avalanche was caused by the earthquake on the ranch of Judge Welch, not far from Long Bridge and within 2 miles of Saratoga. Mr. Herre reports that here the soil on the northwest side of a small creek coming down from the Castle Rock Ridge, was shaken down for perhaps 0.5 mile, tho not continuously. In places the slid material filled up the creek-bed and totally changed the contour. It destroyed the road to the ranches farther up the canyon, and wrecked some bridges. Along the upper part of the area affected, a vineyard was destroyed; while farther down the canyon a heavy forest growth, consisting mostly of redwood, oak, alder, and laurel, was obliterated. This slide lies in the path of the San Andreas fault.

Mr. Herre further reports a large slide on the Mine-lego Ranch, 20 miles southwest of Palo Alto. Here, on the north side of Alpine Creek, a tract of some 50 acres sank at the time of the earthquake, with little or no apparent forward movement. The tract sloped to the south and west, and formed part of a great, open hill pasture, with trees and underbrush about the lower or creek side. The creek-bed itself is filled with a growth of Douglas spruces and other trees. The land, which before the earthquake was steeply inclined, is now comparatively level, the eastern and northern part having sunk perhaps 100 feet, while that on the west has sunk but 10 or 15 feet. The surface of the sunken tract was greatly seamed and cracked, and part of it was flooded, owing to the springs uncovered; but otherwise it was unchanged in appearance. There was no piling up of earth, nor sliding of one portion over another. A fence crost the tract, and the posts on it sank so that but a few inches protruded above the surface; while some Douglas spruces also sank several feet into the earth. A number of cattle were on the land at the time of the earthquake, but were uninjured. It was a work of great difficulty to remove them, block and tackle being necessary. The creek-bed was apparently not affected, nor were the trees in it disturbed. There was no apparent movement of the earth into the canyon, but the whole mass seems simply to have been dropt from a steep slope to a nearly uniform level, surrounded by the high, blank, almost perpendicular walls of earth and rock from which it had been sundered.

Many other earth-avalanches of minor importance were caused by the earthquake in various parts of the Santa Cruz Mountains. At Hidden Villa, 2 miles northwest of Black Mountain, large blocks of rock are reported to have rolled down the slopes. There were numerous slides along Stevens Creek, due chiefly to the caving of the creek banks. Along the ridge road southwest of Stevens Creek, sandstone blocks, some of them 6 feet in diameter, rolled down the hills toward the creek. Near Half Moon Bay considerable masses of granite were dislodged on a steep slope, (Plate 124c.) On the road along Pilarcitos Creek, an earth-avalanche brought down big blocks of sandstone upon the road. (Plate 126B.) At Boulder Creek a large portion of the soil was shaken loose from an abrupt hill 150 feet high, and fell to the level of the creek, carrying trees with it. At the north end of Ben Lomond Mountain, a slide carried trees and brush down to the creek. Near Olive Springs, 12 miles north of Santa Cruz, an earth-avalanche demolished Loina Prieta Mill and killed several men. At many places on the south side of Cork' Madera Creek, huge masses of rock had been thrown down from the steep bluffs into the road, completely blocking it. About a mile from the summit of the ridge, where the Alpine road outers the Pago Mill road, a slide carried away the entire roadbed for a distance of about 300 feet. On PurLssima Crook a slide filled the road for a length of about 100 foot; another, between 0.25 mile and 0.5 mile long, dammed the creek to a depth of 25 or 30 foot. A large slide close<sup>1</sup> to Wright Station partly dammed the stream. On the western slope of the ridge just west of Skyviand, several earth-avalanches were caused by the shock; and great slides of a similar character occurred on both sides of Aptos Creek for 0.75 mile. Besides those, there were many smaller earth-avalanches

in many parts of the Santa Cruz Mountains which can not be enumerated. There were also several such slides on the granite slopes of Montara Mountain, farther north in the San Francisco Peninsula.

In the Coast Ranges to the north of the Bay of San Francisco, earth-avalanches were not so common away from the coast as they were in the Santa Cruz Mountains. There were, however, two notable ones which deserve mention here. The first of these is the Maacama slide, 6 miles east of Healdsburg. (Plate 124A, B.) The slide is about 0.125 mile wide at the top, and 0.5 mile long. The rock is a stratified volcanic tuff, and the slip was down the dip of the beds. The avalanche cut its way thru a fir forest and dammed Maacama Creek. The other is the earth-avalanche which, on May 1, 1906, dammed Cache Creek to a depth of 90 feet at a point 4 miles below the confluence of the north and south branches of the creek. The rock which fell is red sandstone. The width of the slide is 300 feet and its height is 500 feet. The dam thus formed broke one week later. This earth-avalanche can not be so directly referred to the earthquake of April 18 as the others heretofore described; but it was probably indirectly caused by the shock.

#### EARTH-SLUMPS.

By far the most common manifestation of landslide phenomena was that here referred to as earth-slump. It would be wearisome to attempt to mention all the various earth-slumps stimulated by the earthquake, even if information were sufficiently detailed to make this possible. Only two of the more important slides which have come under the observation of geologists will be noted.

*Cape Fortunas earth-slump* (F. E. Matthes).—This landslide, immediately south of Cape Fortunas, is by far the most extensive one on the northern coast. (See plate 127A, B.) In May, 1906, it projected into the ocean for about 0.25 mile, like a hummocky headland of irregular outline; indeed, it formed a new cape on the coast-line, but will doubtless rapidly be cut back by the action of the waves. Its length, in the direction of its movement toward the ocean, is estimated at little short of a mile; its width varies from 0.25 mile to 0.5 mile. Its total descent, from the summit of the higher scarps at its head to the level of the sea, is probably less than 500 feet. Its surface is exceedingly irregular, with many large humps and hollows. Over large areas the sod is more or less rhythmically broken by deep cracks extending at right angles to the direction of movement. These cracks are only a few feet apart, and the sod-blocks between them lie mostly in tilted attitudes, making the area exceedingly difficult to traverse. The general aspect is not unlike that of a much crevassed glacier. In some places, however, the mass seems to have been torn apart so completely that the sod is not merely broken but almost swallowed up or buried, the browns and yellows of the under soil being the prevailing tints. Around its head are a number of steep scarps, from 100 to 200 feet high. They are especially prominent on the north side, and again toward the southeast; but over considerable stretches between these two sets, the broken surface of the slide joins the unbroken hillsides to the east without significant offset. Owing to this, the slide is easily approached from the wagon road (from Centerville to Cape Town), which passes close by its head. The longitudinal profile of the landslide is one of gentle slopes for the most part; its declivity is not at all great, and in a few places even reversed slopes occur. Its noteworthy feature is not its vertical drop but its great forward movement. In a sense it has flowed like a partially plastic mass, expanding and advancing 0.25 mile beyond the coast-line, but descending only a few hundred feet.

In its general aspect, as well as in the nature of its movement, the Cape Fortunas landslide is altogether different from those observed farther south, particularly along the mountainous coast both north and south of Point Delgada, which, in effect, did little

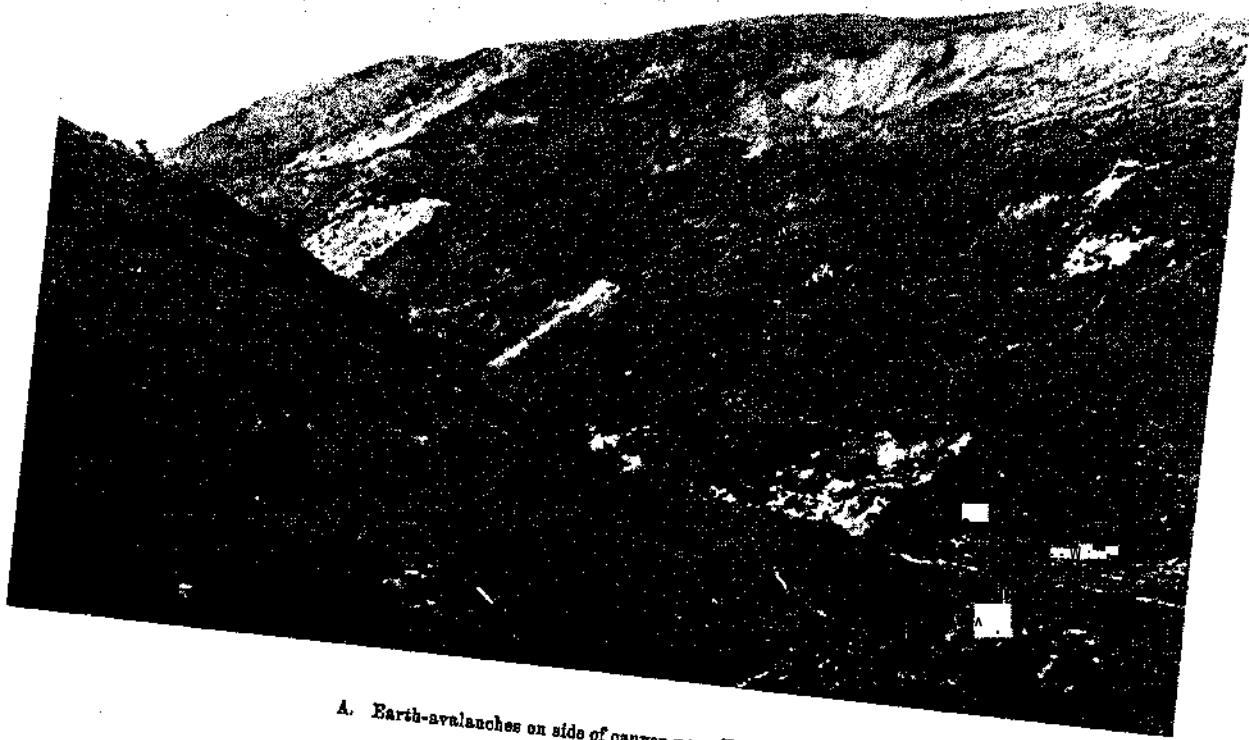

A. Earth-avalanches on side of canyon near Chittenden. A. C. L.

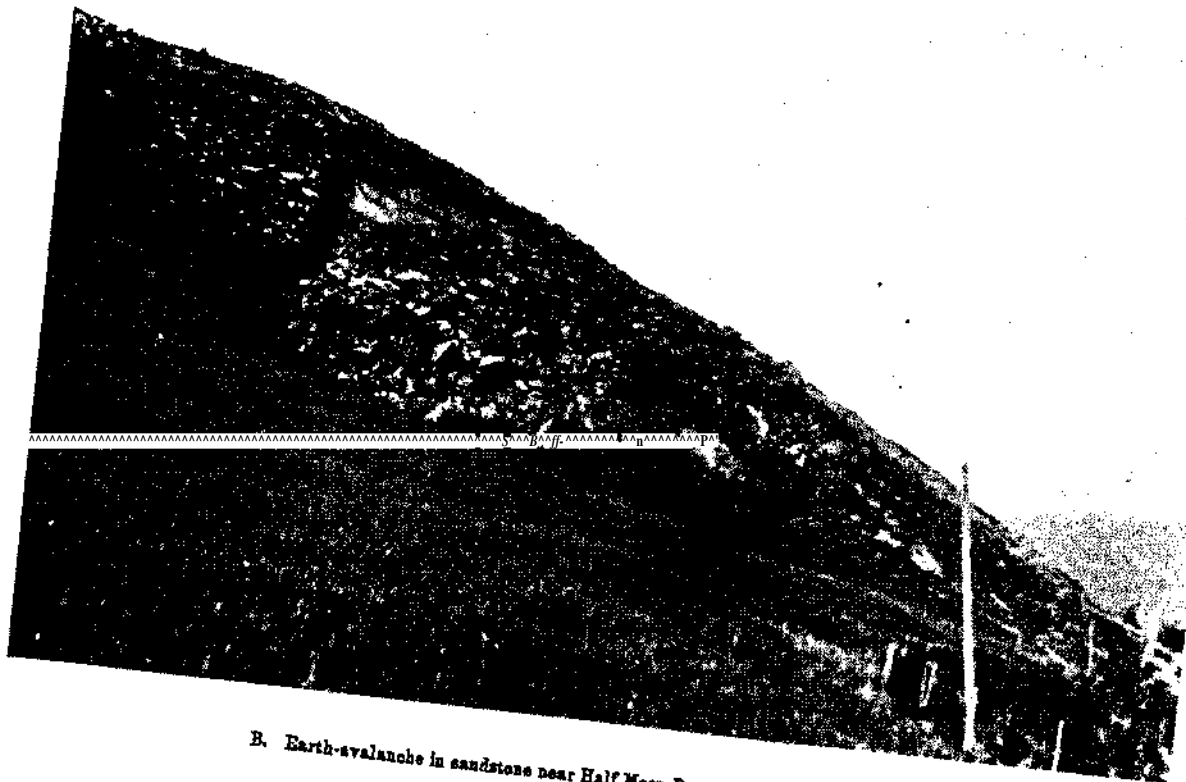

B. Earth-avalanche in sandstone near Half Moon Bay. Slip on bedding planes. E. D.





A. Earth-slump at Oape Fortunas, Humboldt County. A. S. E.

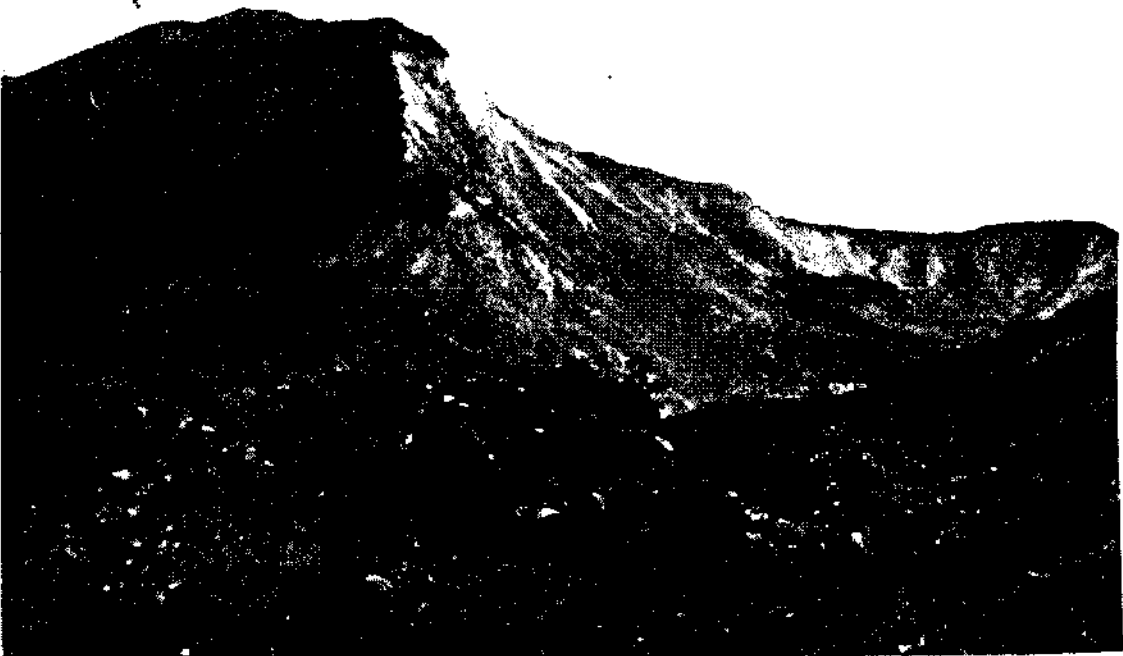

B. Earth-slump at Cap Fortanw, HamHMt Oesmtj. A. 8. E.

else than revive a series of old landslide facets. This may not be apparent to an observer on the beach, but is quite striking when the coast is viewed in its entirety from a vessel off-shore. These facets existed before this earthquake, and had been recognized as such. They are conspicuously outlined against the dark timbered slopes behind them, rising from 1,000 to 2,000 feet above the shore, and affording an important series of landmarks for the mariner. In strong contrast with these bold mountain forms is the region in which the Cape Fortunas landslide took place. The land here can scarcely be called mountainous; and while it breaks off in cliffs at the coast and is traversed by many fairly deep draws, it is essentially a region of subdued relief. Great declivities are notably absent, except in the sea-cliffs, and even these are only a few hundred feet high. At the same time, evidences of former landslides may be seen on every hand. They are not extensive, as a rule, and are as likely to occur on gentle slopes as on steep ones. In a few cases only is a marked downslip noticeable, resulting in the uncovering of a steep scarp; in nearly every instance the dislocated mass appears not so much to have sheared off and dropt from its former position, as to have expanded or slumped, with an accompanying subsidence of its surface. The billowy and irregularly pitted appearance of these areas, together with the rank vegetation that covers them, afford the principal marks of identification. Both from their characteristic form, suggestive of plastic flow, and from their mode of occurrence, it seems reasonable to infer that ground-water plays an important rôle in their genesis. They are apparently masses which have changed their shape in obedience to a lessening of cohesion in their interior, through saturation with water. Whether the movement be initiated by an earth-tremor or not, it is in every case essentially an adjustment to a more stable position, rendered necessary by a change in the physical constitution of the mass.

It is to this category of landslides that the one at Cape Fortunas belongs. While there are scarps in various places at its upper end, these are really insignificant features alongside of the extensive tract of the slide itself. What downslipping occurred on these scarps was merely an incident in the entire movement. Both in the large ratio between its horizontal advance and its vertical drop, and in its general appearance, the Cape Fortunas landslide is closely analogous to the numerous lesser slides referred to; and there is good reason for the belief that, like them, it consisted essentially of an adjustment of equilibrium in a partially water-saturated mass. It probably had long been imminent before the earthquake started it,

*San Pablo earth-slump.* — At the time of the earthquake a landslide occurred on Mills' ranch, which is about 4 miles east of San Pablo. The slide is interesting from the fact that a previous geological mapping of the region indicated that the point where it occurred was on the line of a fault extending in a northerly and southerly direction through the Sobrante Hills. The slide was examined by Mr. E. B. Larson, who describes it as follows:

There are many other landslides in this vicinity, showing that the country is subject to such slides. In this particular case, one of the Castro boys informed me that the main part of this slide began during the winter rains, and had fallen a foot or more during these rains. The balance of the fall occurred the morning of the earthquake. The slide is on the east slope of a steep hillside and extends from the top of the hill nearly to the bottom, about 400 feet on the slope. The width is about 1,500 feet. At the northeast corner the scarp is greatest, reaching perhaps 50 feet. It gradually decreases, and is very slight for the southwest 700 feet, in this southwest 700 feet the only evidence of a slide is the crack near the top of the hill. The north 800 feet of ground shows every evidence of sliding. The dry ground is much cracked, and these cracks extend up and down the hill near the scarp and along the hill where the ground has been piled up. In some places there is a network of cracks. On the south side of the main slide the ground has piled up about 10 feet. This extends along nearly all of the south side, and this tendency to pile up to the south is shown in other places. Moreover, the north side shows that the ground has pulled

away toward the south. The above shows that the movement was not directly down the hill, but was more to the south. The formation is sandstones and shales, with considerable soft surface soil.

The same slide was subsequently visited by Mr. F. E. Matthes, and the following descriptive note is by him. (See figs. 68 and 69.)

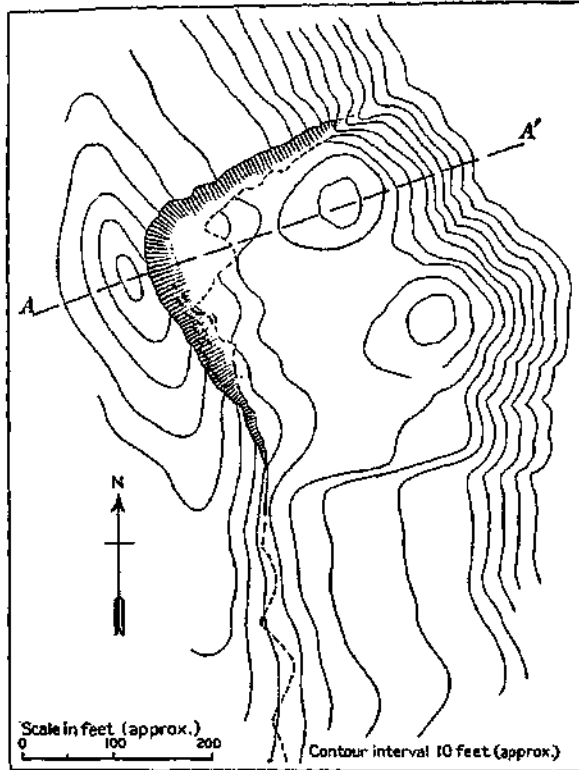

FIG. 68.—Map of landslide caused by the earthquake east of San Pablo.

The slip occurred east of a high ridge at the southern end of the Sobrante Hills. It covers the northeast half of an area whose terraced nature is indicative of a former landslide of much larger dimensions. The accompanying sketches show the general outlines, and a cross-section of the slide. It will be noticed that the slide does not extend all the way down the slope, its lower edges being fully 100 feet or more above the bottom of the gulch. The lower slopes were not materially changed, and but little debris fell into the stream-bed.

A steep scarp has been produced east of the crest of the ridge. The downslip along this scarp does not exceed 50 feet, and decreases both to north and south. Along the north edge there has been a marked movement down and southward, the scarp there averaging 10 feet. Along the south side, on the other hand, the loosened mass had advanced over the old surface, presenting a bulging and cracked frontal scarp some 6 feet high. It appears from this that the movement took place, not along the line of greatest declivity, but in a direction somewhat more southward, as indicated by the arrow. The 2 hummocks probably existed before the slip occurred, but judging by their greatly cracked and rent surfaces, it seems likely that their height has been slightly increased. The main crack, which extends southward from the upper scarp, continues along the hillside in irregular zig-zags for some 300 feet south of the slide. (See plate 128A, B.)

Other earth-slumps referred to under the section on the Distribution of Intensity are shown in plates 125B and 129A, B, V, D.

#### EARTH-FLOWS.

*Mount Olivet Cemetery (A. C. Lawson).*  
— Perhaps the best illustration of an earth-flow caused by a sudden accession of water to the incoherent materials of a slope, in consequence of the earthquake shock, is that which occurred in the upper part of Mount Olivet Cemetery, near Colma, 9 miles south of San Francisco. The locality is at the base of the San Bruno scarp, and about 2.75 miles northeast of the San Andreas

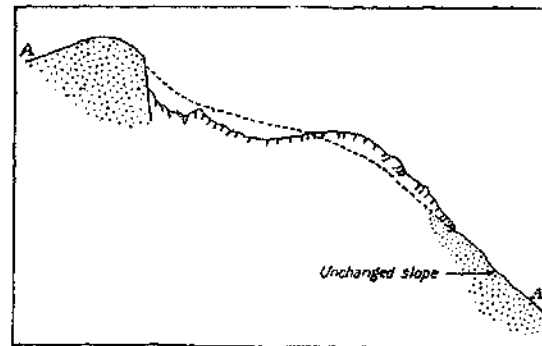

FIG. 69.—Section of landslide shown in fig. 68, along the line A-A'.



A. Eaitli-alump east of Saa Pablo. F. E. M.



B. Earth-slnmp east of San Pablo. P. E. M.



A. Earth-slip north of Tomales, carrying railway roadbed with it. Track was straight before earthquake. R. S. H.

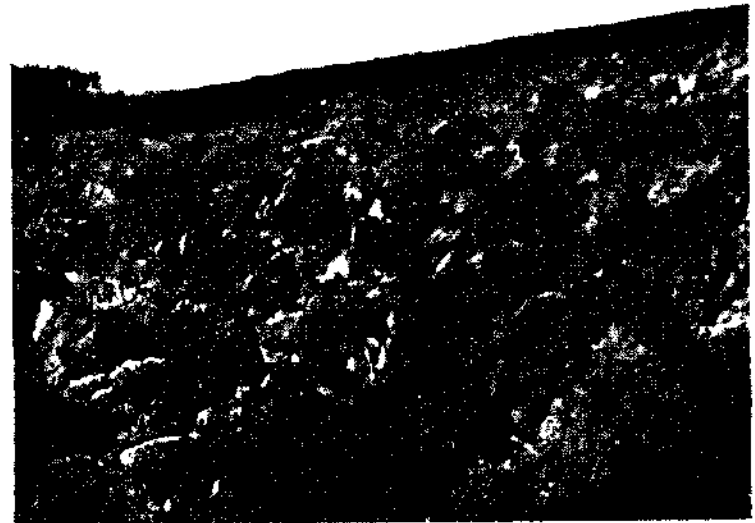

B. Earth-slip 3 miles northeast of Tomales, at Freeman's, E. B. H.



C. Earth-slip at Mussel Rock. Old slide suddenly accelerated by earthquake, 0.



D. Scarp of Mussel Rock earth-slip. 0.



A. Earth-flow at Mount Olivet Cemetery, Source of flow looking down. A. O. L.

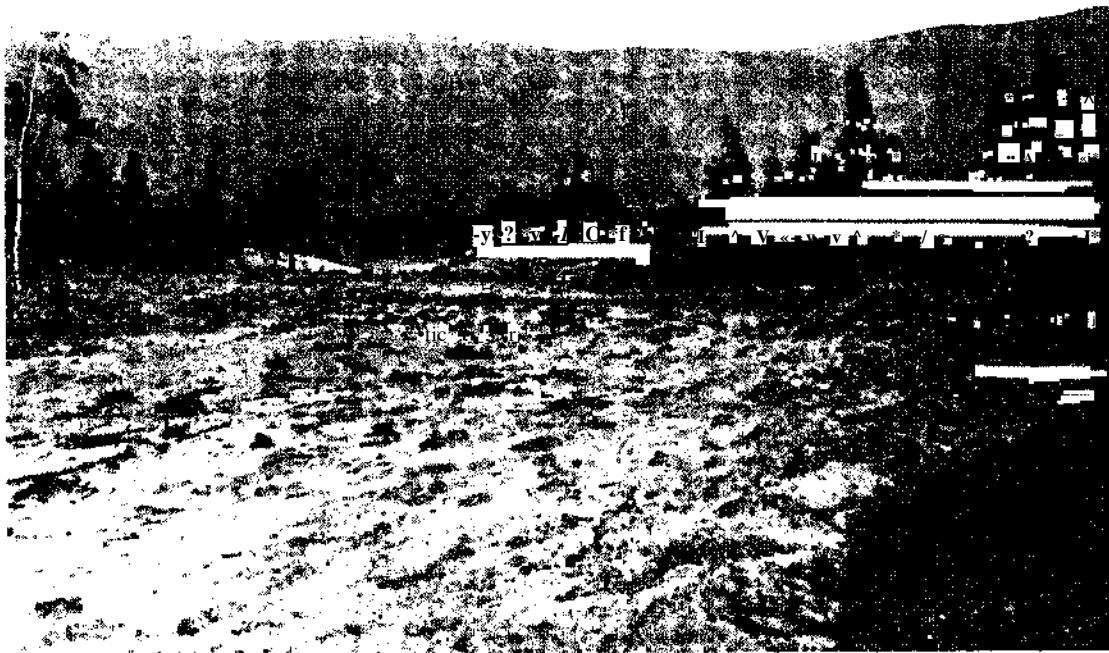

B. Earth-flow at Mount Olivet Cemetery. Path of flow, looking up. A. O. L.



A. Earth-flow, Mount Olivet Cemetery, at base of San Bruno soap. Looking northwest, A. O. L.



B. Earth-flow at Mills east of Half Mora Bay. B. A.

fault at Mussel Rock. The steep slope of the scarp is underlain by hard sandstone of the Franciscan series, with but a thin veneer of soil, or none at all. At the base of the scarp is the gentle slope of Merced Valley, underlain here by Pleistocene and recent sands. The sands, partly eolian, lap up on the lower flanks of the scarp, and mantle the trace of the auxiliary fault which follows its base. The sands thus vary in thickness from a feather edge to an unknown thickness, which it is believed may be as much as a few hundred feet at no great distance from the base of the scarp. Traversing the gentle slope of the valley-floor are several shallow arroyos, which head in incipient ravines in the face of the scarp. At the moment of the earthquake there was a sudden outgush of sand and water at a point at the upper end of the cemetery, close to the base of the scarp and quite near, if not immediately upon, the line of the buried fault-trace. This stream of sand and water, admixed with the loam of the slope, flowed rapidly down the course of a shallow arroyo on a grade of about 1:25 with a depth of from 13 feet in its upper part to about 3 feet in its lower. The front of the stream stopt abruptly at a point just beyond the roadway about half a mile from the origin. The flow was so rapid that it carried away many small trees; a wind-mill was wrecked and the heavy concrete blocks which served for its foundation were swept down, with other debris. One of the pumping stations of the cemetery was demolished by it, and 2 horses were carried off their feet, and were extricated afterwards with difficulty. (See plates 130A, B and 131A.)

According to Mr. M. Jensen, the superintendent of the cemetery, the entire flow had been accomplished within 3 minutes from the time of the shock, and he was at its source within 20 minutes after it occurred. The height of the flow within a few hundred feet of its source was attested by the mud upon the trunks of some eucalyptus trees near its margin. This mud extended up to 13 feet above the bottom of the arroyo. This, however, doubtless indicates the height of the front of the stream as it past this point. As the flow advanced, its surface near its source rapidly dropt; and by the time the front had reached the roadway the stream was probably no deeper at its source than at its terminus. Indeed, it seems to have been somewhat less, as there was a marked tendency for the sand to pile up at the front by reason of the negative acceleration at the front due to loss of water. After the moving mass had come to rest and partially dried out, it was found that it had left a streak of muddy sand on the bottom of the arroyo averaging 100 feet wide and about 3 feet thick. Taking the length of the flow as 900 yards, this gives the total volume of the compacted wet sand as 89,100 cubic yards. The cavity in the slope caused by the evacuation of this sand and loam was not measured, but was estimated to have a width of 150 yards, a length of 300 yards in the direction of the flow, and an average depth of 2 yards. On this estimate, its volume would be about 90,000 cubic yards, which agrees quite closely with the estimated volume of the material ejected.

The sand, after it had ceased flowing and had been drained and compacted, undoubtedly held in the voids between the grains not less than 25 per cent of its volume of water. An additional 15 per cent would probably give it the necessary fluidity for flow down a slope of 1:25. But as the flow was swift, there was an excess of water, so that probably 25 per cent would have to be added to give it the properties manifested in the actual flow. The sand, however, in its original position before the time of the earthquake, probably did not contain more than 20 per cent of water, since the upper or soil layer had been somewhat dried out by the air. To the original sand of the slope, therefore, there must have been added 30 per cent of its volume of water to cause it to behave as it did. This amounts to 27,000 cubic yards. This water came from ground immediately below the source of the flow; and it came in a moment, at the time of the earthquake. It is only another way of stating the facts to say that it was squeezed out. There was



no disturbance of the soil on either side of the cavity, even in its immediate vicinity. On the shoulder to the southeast, where the trace of the auxiliary fault passes over practically bare rock, no evidence of movement was detected on critical examination. The expulsion of the water was a purely local phenomenon. In attempting to explain the cause of it, or to ascertain the local subterranean conditions which conspired with the earthquake shock to bring about the event, it should be noted first that on the line of the fault-trace there are longitudinal depressions, which appear to be in part structural and in part due to erosion following the fault. If one of these depressions should locally have the character of a sink, without free drainage, then the sand which filled it would be saturated with water in consequence of the rains of the previous winter. It is believed that the compressive action of the earth-wave passing through such a pocket of saturated sand, and reflected perhaps more than once from the containing rock walls, would be adequate to expel 27,000 cubic yards of water from the deeper portion and add it suddenly to the more superficial portion of the formation, thus bringing about the earth-flow. It may be stated in this connection, although it has no conclusive bearing upon the question involved, that the sands of the valley generally are an abundant source of well water, and that there is a surface well within a few hundred feet of the source of the earth-flow, lower on the slope. There was very little water in the arroyo before the earthquake and a very insignificant stream afterwards, the latter being probably referable to the drainage from the ejected sand.

*Vicinity of Half Moon Bay* (Robert Anderson).—The earthquake shock caused the appearance of an unusual amount of water at the surface in many places. This was noticeable in the vicinity of San Bruno, where several short streams running into the bay were flooded by an unusual volume of water during the first days following the earthquake, in spite of the fact that it was perfectly clear weather. Instances have been cited in the present writer's notes on the results of the earthquake in the San Francisco Peninsula, of water with a salty taste or milky color issuing from springs after the shock, and of streams being muddy and flowing with increased volume. These facts, and the fact that water continued to issue after the earthquake at the points where earth-flows occurred, and where it had not been in evidence before, and that earth-flows occurred sometimes on convex slopes where the concentration of water under normal conditions would be unlikely, seem to be explainable only by the theory that underground conduits were disturbed and made more open, that new channels of escape for the water were formed, and that water was actually squeezed out of the hills in some cases by compressive movements. This flowage of water to the surface, in increased amounts and sometimes at new places, caused the formation of the earth-flows. The places where these debacles occurred may or may not have been previously points of concentration of seepage water, and the soil already in part saturated. But it is supposed that the content of water was increased by the shock, possibly in extreme cases by the gushing up of a large volume; and that this increment of water, with its disintegrating, weighting, lubricating, and direct forcing power, aiding the attack of the shock on the soil, was the main cause of the earth-flows.

There is little evidence as to when the flows were first set in motion; whether at once during the shock, or later after the lapse of some brief period of time that may have been necessary for the accumulation of the water in extra large quantities.

Earth-flows originated in valleys, in gullies, or on hillsides. Where the weight of the earth, combined with the weight of the added water, was sufficient and the substratum of the soil was rendered plastic, gravity caused it to creep like a lava-stream, leaving a hollow in the place from which it came and a fan or tongue of debris down the slope below. Movement was especially apt to ensue where the ground had been previously wet, the intensity of the earthquake shock being particularly great at such points and



A. Earth-flow in Mills east of Half Moola Bay, R. A.



B. Earth-flow in small valley near Half Moola Bay, E. A.

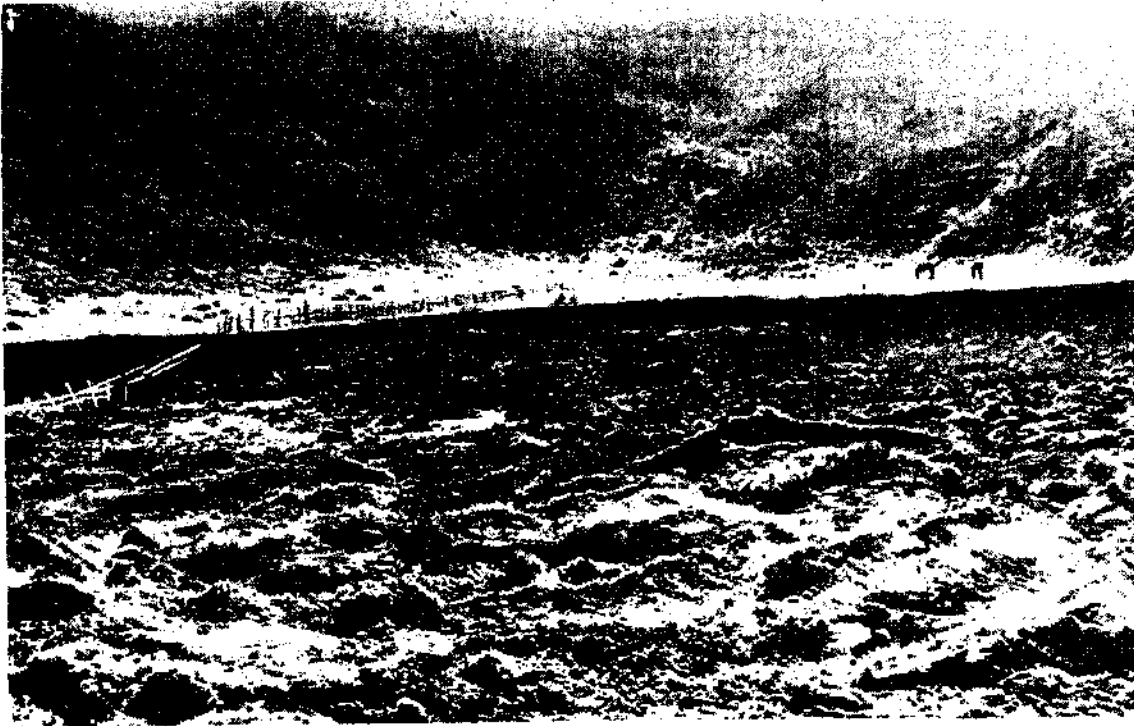

A. Earth-flow shown in Plate 132 B, illustrating floor of cavity from wMoli flow oame. E. A.



B. Earth-iow 4 miles east of Half Meoa Baj. E. A.

the tendency of the vibrations being to set the mass in motion. Earth-flows occurred in many places in the Coast Ranges, and probably thruout the region in which the shock was heavily felt. The writer found many of them, large and small, on the San Francisco Peninsula and in the Santa Cruz Mountains, also in the Mount Diablo and Mount Hamilton Ranges.

Following are descriptions of 5 earth-flows that occurred on the morning of the earthquake in the neighborhood of Half Moon Bay, which is on the coast 25 miles south of San Francisco:

One of them was formed in the hills bordering the terrace at Half Moon Bay, immediately south of Frenchman Creek, 1.5 miles north of the town, and a mile from the sea, at an elevation of 100 feet. It is pictured in plate 132A. At this place the earth caved away in a crescent-shaped area on a slope of only  $18^\circ$ , and flowed out in two long arms so as to leave a hole 4 feet deep, surrounded by vertical walls of unaffected soil. The flow occurred at a fairly high point on a gently undulating incline. The discharged earth was divided by a mound, at a point 150 feet below the summit of the arc, and followed two courses which were determined by gullies on both sides. Much of the débris overflowed the central mound at the same time, and inundated the barley fields to a depth of 2 to 4 feet, for 100 feet farther. On both sides of the central mound the caving away continued to the same depth. In the left-hand fork it stopt within a few feet, and the flow did not extend very far beyond. In the right-hand fork a cut 100 feet long and 50 feet wide was made, the earth flowing down from it 250 feet farther over the grain field, as shown in plate 132A. Thus the whole length of the slide was 500 feet. The width of the main hole was on the average about 100 feet, and the length, as already mentioned, 150 feet not including the arms.

In this hollow in the hillsides many dry blocks of sod carrying growing grain — usually in an upright position — were left stranded 4 feet below the surface of the hill by the removal of the subsoil. The fence that crost this area was broken and carried away and partly buried. Where the caving ceased in the right fork, a ridge of debris was piled up across the mouth of the hole, much higher than the stream of loose material that flowed farther. Similar ridges were heapt up across the path of the flow, where the breaking away of the hill stopt in the other arm and at the upper end of the central mound.

The south or right arm of the flow extended down the hill at an angle gradually decreasing from  $18^\circ$  to less than  $5^\circ$ . Large parts of the fence were carried on its surface for 300 feet.

Plate 132A gives a detailed view of the lower extremity of the right arm. The stream came to an abrupt stop, like a quickly cooled lava flow, and preserved a face 1 to 2 feet in height above the grain field. The surface of the flow consisted largely of blocks of sod, usually almost upright, which were carried down from the hole without much moistening, or transformation into material capable of flowing. The bulk of the flow was a moist aggregate of earth fragments possessing something of their previous form and grading into mud, which assumed a semi-fluid consistency underneath. The bottom of the hole, and the flow itself, remained too muddy to walk on for weeks after the earthquake, and the field below the lower end of the large arm was left marshy, tho it had not been so before. It is to be noted that several fairly heavy rains followed the earthquake after an interval of several days, and before these earth-flows were visited; but these were not sufficient to account for the amount of moisture observed. The chief effect of the water was in the ground at a depth of 3 or 4 feet below the surface. It rendered the soil sufficiently fluid to enable it to flow down the gentle slope, probably partly oozing from under the surface crust ami partly transporting the sod with it. Most of the surface was carried down with the main flow, the stranded sur-

face blocks that remained in the cavity being accountable for as fragments from the broken edges subsequently giving way and being carried only a short distance as the upper end of the flow came to rest. In this way, probably, the walls were trimmed, for the cut in general was left remarkably clean.

Another flow of similar character took place 3 miles north-northwest of the town of Half Moon Bay, on the creek next west of Frenchman Creek. It is shown in plates 132B and 133A. On the morning of the earthquake an acre of the gently sloping alluvial floor of a broad, short valley tributary to the main creek on the east caved and flowed out, leaving an excavation 10 feet deep, where before it had been almost level and where there had been no stream channel. In this case, the water already gathered in this basin-like valley, which here had had no means of prompt escape, was an important aid in the formation of the flow, aside from the sudden accession of water that probably caused the earthquake. The presence of a large amount of water and the forcible movement during the earthquake shock resulted in the loosening and undermining of the ground and its transportation as a fluent mass. The angle of slope was about 5°. The flow carried out thousands of tons of earth in this manner and spread it over about 2 acres of meadow land, to an average depth of 1.15 to 3 feet.

Plate 132B gives a view of this earth-flow, showing the pit from which it was derived. Covering much of the surface of the flow and the floor of the hole are to be seen blocks of sod which have been carried right side up as if the material had moved *en masse*. The amount of water in evidence shows clearly how the earth was softened and enabled to move. The picture was taken two weeks after the earthquake. At that time water was still seeping up from underground, and out of the lower portions of the broken walls, while the ground near the surface of the valley was quite dry. The water had formed two definite rivulets thru the débris, at an elevation above the surrounding meadow, and was running in continuous streams, fast cutting a channel for itself and removing the soft material. Considerable water was dammed back in the hole by a 4-foot ridge of débris piled across the mouth of the hole, as in the case of the previously described earth-flow. This mound of earth, along the line where the stream left the caved-in area and flowed over the preexisting slope, was probably piled up at the last by the remnants of the flow gliding down and heaping themselves up as a barrier at the mouth of the hole.

The cavity, about an acre in extent, has 10-foot walls which gradually decrease in height lower down the valley, the bottom of the hole being more nearly level than the valley-floor. Plate 133A shows part of this flow in detail.

Some of the great blocks of sod around the edges have not been removed, altho the material from underneath has gone. Concentric cracks not visible in the pictures extend around the edge of the hole and for 50 feet above its upper end, showing that the area affected is broader than appears at first sight, and that the work is not yet all accomplished. The material of the valley-bottom is a coarse, arkose earth, derived from decomposing granite, and containing many rock fragments.

A flood of earth covers about 2 acres of the meadow. Water was present in this earth-flow in greater amount than in any other that was examined. The nature of the material may be judged of by the abrupt face of the stream where it stopt. The edge makes a steep angle with the meadow and rises to an average height of 2 feet above it. Yet the fact that this mass of earth was able to move more than 300 feet after it left the lower end of the hole, and spread into an even and thin layer over a wide extent of nearly level meadow, shows that it was fairly soft. It was moved on a basal layer of semi-fluid mud and sand, with the aid of the weight of the overlying and partly disintegrated earth.

The largest of the earth-flows seen occurred in the canyon south of the house of Mr. Nunez, 2.5 miles east-northeast of the town of Half Moon Bay, at an elevation of about 500 feet. It originated in a manner similar to the others, but in a canyon along which there is a distinct but ordinarily dry stream channel. A long, irregular hole from 4 to 7 feet deep was excavated near the head of the valley, and a great volume of earth flowed down its curving course for 0.25 mile, as far as the Nunez house, and there stopt, being in part diverted into the main creek to which the valley is there tributary. According to the testimony of witnesses, the flow reached the end of the 0.25 mile in 0.5 hour after the earthquake shock. It was seen gliding slowly down and engulfing the orchard just back of the house. According to observers on the Nunez ranch, the earth-flow was not accompanied by any water; but two weeks later, when examined by the writer, it preserved every evidence of having been muddy. Especially was this true at the bottom, where great masses of mud still had the consistency of jelly. It is probable that there was no flowing water on the surface of this or other earth-flows at the time of their formation, and that the presence of water in the flow was not evident to the casual observer because of the comparative dryness of the material on its upper surface.

The slope of the canyon down which the moving body of land crawled is about  $25^{\circ}$  near the head and decreases to  $15^{\circ}$  farther down. The flow filled this to a width of 100 feet on the average, and to a depth varying from 10 to 20 feet. The inertia of the mass is illustrated by the fact that in the early stage of the flow the earth was piled 20 feet higher on the hill, on the inside of the big curve made by the canyon, not far below the pit, than it was when the flow came to rest. The marks at this elevation were probably made very soon after the main mass was discharged from the cavity, before it had spread very widely. The central portion of this earth-flow is pictured in plate 131B, where it appears as a ridge many feet high rising above the tall grass on the hillside, on the right of the picture. The pressure of the material at the head of the flow, as it started, was so great that the earth bulged up over the sides in places, in such a way as to force upward great blocks of sod and turn them on edge or completely over, away from the rim of the hole.

The flow assumed the form of two lateral ridges and a central depression, or channel. The ridge on the west or inner side of the curve was considerably the higher. The form was due partly to the concavity of the valley; but chiefly, it is thought, to the tendency of the more fluid material to follow the deepest possible path along the gully under the center of the flow. Thus the drier material was retarded at the sides. Subsequent to the first starting of the flow, a stream of semi-fluid mud and sand continued to run down the central channel, covering its sides with a coating of mud and leaving flowage striations on it. This channel and its markings are exhibited in plate 131B. Two weeks after the earthquake, when the photograph was taken, water was running in this channel and had cut down into it several feet deeper. Its bottom, however, was still from 5 to 10 feet higher than the bottom of the underlying preexistent water course, where water had not flowed before at this time of the year. The man in the picture is standing at the bottom of the gully. To the left of him, the hammer and note-book mark the top of one of the parts of the lateral ridge which is here divided into several hummocks. To the right is the other and higher lateral ridge. The foreground was formerly covered by a dense thicket of willow trees. These willows have been completely buried, except at the sides where some dead brandies protrude. A fence that erost the canyon was torn away for 100 feet, and not a trace of it could be found. The fence shown in the picture is one newly built in its place.

Two other smaller earth-flows occurred just over the hill westward from the last one described. They are shown in plate 133n, the canyon on the left being the one occupied

by the Nunez flow. One of these 2 earth-flows, that at the right of the picture, started near the top of the ridge in a depression in the slope, formed a hole 75 feet long and 40 feet wide, and coursed down a narrow runnel having a gradient of  $25^\circ$  to the bottom of the hill, a distance of 600 feet. Enough earth issued to fill up the rather deep ditch in the gully clear to the bottom of the hill and to bury the grain field on both sides to a depth of 1 to 2 feet. In this case, as in the preceding one, there were formed lateral ridges higher than the center, so as to leave a groove between. Down this channel there flowed softer material, which lined the sides of the lateral ridges with a smooth coat of mud and left conspicuous flowage marks. The flow thus raised a ditch for itself above the level of the slope. The earth-flow probably assumed this form by leaving behind, at the sides, the material least capable of flowing, and by concentrating its most liquid parts along the deep central line.

The other earth-flow was near by, on the convex face of the knoll in the center of the picture. A similar cavity was produced, from which the contents were spread out broadly. It is a good example of the starting of a gully, as there was no depression before. One branch of this earth-flow came straight down the hill and slightly toward the canyon on the left; the other branch came down toward the gully in which the first-mentioned of these 2 earth-flows occurred. Thus drainage lines were started which ultimately may separate the central hill from the ridge on the right, of which it is now a continuation. The left arm of the flow on the hill may develop a channel, as explained below, which will cause the drainage from this hill, which is now toward the foreground, to pass into the canyon on the left.

Similar landslides, tho usually of smaller size, occurred thruout the region neighboring the fault visited by the writer, and even in districts at a considerable distance from the fault. Frequently they were not definitely referable to the earth-flow type, but resembled more closely earth-slumps formed without the aid of a suddenly increased water supply. It was often difficult, especially in cases where the movement was slight, or the slide was in the embryonic stage, to determine whether the earthquake at those points had caused a flow of water or not. In the instances so far described, it was pretty certain that it had; but in many others the phenomena were explainable as being the result of moisture that was already collected before the earthquake. Many slips were formed on hillsides and along the embankments of mountain roads, and along the cracks formed by the shock in moist and loosened soil. Often these slips were arranged one above another, the perpendicular faces due to slipping having the appearance of step faults. In such cases the weight of the moved mass and the amount of water was not sufficient to cause the material to flow. There were examples of such slips along the coast hills north of San Pedro Point, near the road halfway between San Bruno and San Andreas Lake, near the road from Belmont to Crystal Springs Lake, 0.5 mile southeast of the San Mateo Alms House, and in many other places on the San Francisco Peninsula. In some places bare ridges had their lines of symmetry broken into little knolls and irregularities by these slips, a common occurrence in the hills of soft sand formations in the northern part of the San Francisco Peninsula. All the slips just referred to illustrated the gradation between earth-slumps and earth-flows. Doubtless in many of them a small amount of water did gather as a result of the earthquake.

*Relation of earth-flows to rainfall* (Robert Anderson). — The rainfall previous to the earthquake, tho possibly of little importance in connection with the more extreme types of earth-flows, in which practically all the work was done by a head of water brought from underground by the shock, bears a close relation to the less extreme types, and to the geologically very important doubtful types intermediate between the earth-flows and earth-slumps. In a dry year the number and size of all of these would probably have been much less. Had covering of slopes been unsaturated, areas might not

have been so ready to break forth at a sudden accession of water from below; and the rainfall not having been great, there might not have existed such a plentiful source of underground water to be drawn from. The following review of the rainfall conditions may be of value in indicating a relation between the preparedness of the ground and the number and importance of flows and slumps.

During the first three months of 1906 the rainfall was exceptionally heavy thruout California, being on an average thruout the whole State more than 9 inches in excess of the normal for that period. Up to the beginning of 1906, the amount of rain for the season was 4.5 inches below the average; but owing to the great excess during the late winter and early spring months the total for the year up to the first of April, the month in which the earthquake occurred, was nearly 5 inches above the normal. During January, February, and March the rain was heavy and continuous. Nearly all the rain of the season was during these months immediately preceding the earthquake month. Practically no rain fell between April 1 and April 18.

All of the rainfall data available in the monthly reports of the Weather Bureau for California, compiled by Professor McAdie, has been used for calculating the amount of rain in 8 counties south of San Francisco. These are San Francisco, Alameda, San Mateo, Santa Clara, Santa Cruz, Monterey, San Luis Obispo, and Santa Barbara. The average rainfall at 46 different places distributed thru these counties was 22.59 inches from September, 1905, to April 1, 1906, between 2 and 3 inches above the normal for this region. The excess would have been greater but for the lightness of the rainfall during the autumn term, which was 3.55 inches, or several inches less than the average for former years. During the spring season up to April 1, the precipitation was excessive. During the three months that preceded the earthquake, 19.04 inches of rain fell, or 84.30 per cent of the whole precipitation up to that time. During the first half of April, there was practically no rain at all. Thruout this region, as well as thru California as a whole, March was a very rainy month; especially heavy downpours coming everywhere in the State during the last days of the month. It was the rainiest of the months except in parts of Santa Clara and Santa Cruz Counties, where more fell in the month of January.

The majority of the earth-flows and earth-slumps that occurred were near the coast, although the amount of rain that fell was not as large there as it was farther back in the mountains. The coast region, however, is subject to heavy fogs, which precipitate some moisture and help to prevent evaporation of the moisture already present. These fogs were probably a factor in causing the earth-flows and earth-slumps near the sea. The principal cases described were near Half Moon Bay. The records from Point Montara, only a few miles away, showed that the rainfall in this vicinity was heavier than at any other point along the coast south of San Francisco. During the spring season up to April 1, it amounted to 23 inches, and during the autumn season it amounted to 12 inches. The table shows that the heaviest rains wore in the Santa Cruz Mountains. At Boulder Creek, in Santa Cruz County, 55.70 inches of rain fell during January, February, and March alone, and 10 inches fell during the four months preceding.

During the spring of 1900, a large part of the precipitated moisture remained in the ground, which was previously dry, and the amount of evaporation was minimized by the continuous succession of cloudy and rainy days. The year afforded an example of the concentration of an excessive annual rainfall into a short period, with all the conditions favorable for the absorption and retention of the moisture in the ground. For this reason, conditions favored the production of debacles of various kinds in the loose material covering slopes.

The earth-flows that have been diseust are more or less similar to the flows occasioned by the bursting of peat-bogs. The causes of their origin and their nature appear to be



much the same.<sup>1</sup> Sir William Conway has given an account of a mud-avalanche,<sup>2</sup> a swift torrent of mud, water, and great rocks, in the Himalayas, somewhat similar in nature to these earth-flows. Streams and torrents of mud somewhat analogous but usually of glacial or lacustrine origin have been known to flow in the Alps. Mention of these has been made by T. G. Bonney.<sup>3</sup>

Earth-flows are important as giving rise to new drainage lines and modifying old ones. They are also powerful transporting agents. The initiation of a new drainage line is a matter of importance. Once started, it is a point of vantage for the attacks of agents of erosion, which thereupon are able to increase their work at an accelerating rate of speed. Only next in importance is the definition and fixing of embryonic depressions and gullies. Both these processes are carried out vigorously by these earth-flows, besides other processes such as the enlargement of valleys and channels already formed, the transportation of material, the destruction of the regularity of contours, and the transformation of surface rock material into a form easily removable otherwise, thus in every case supplying better leverage for further destructive action.

Earth-flows usually originate in minor depressions or in already well-formed gullies or valleys, these being the places most subject to the concentration of water; but in some instances they occur on the convex face of a slope, where the removal of soil develops a depression for the first time, and a new drainage line is made possible. The soft debris that is removed, although piled higher than the surrounding slope, lends itself easily to the formation of rivulets by the water that rises and collects in the excavation that is left. These small water-courses, once formed, control the line of flowage, and result in a sort of superimposed drainage when they have worn through the debris to the original slope below. Earth-flows of the above varieties, large and small, with the closely related types of earth-slumps, are thus among the important initial steps in the development of drainage lines in the California hills.

#### EARTH-LURCHES.

Of the three kinds of landslides thus far referred to, the first two, earth-avalanches and earth-slumps, occur quite commonly independent of earthquakes. Of the third kind, or earth-flows, the only examples that have been presented are immediately connected in genesis with the earthquake of April 18, although it is conceded that sudden accessions of water to loose earth might arise in other ways and occasion earth-flows. As regards the fourth type, the earth-lurch, it is difficult to conceive for it any other origin than an earthquake, since it is caused directly by the horizontal jerk of the ground and can not be produced in any other way. In the detailed account of the distribution of apparent intensity, a brief account of these superficial movements of the ground has been given and need not here be repeated. They are best exemplified on the flood plain of the Eel River, west and north of Ferndale; the flood plain of the Russian River; the flood plain of Alameda Creek, near Alvarado; the flood plain of Coyote River near Milpitas; the flood plain of Pajaro River; and the flood plain of the Salinas River. (Plates 136A, B and 137A, B.) In all these localities cracks were formed in the alluvium, generally parallel to the stream trench, and the ground between the cracks was caused to lurch horizontally toward the stream, usually with a rotation of the moved mass, which gave to it the profile of a Basin Range fault-block in miniature, the portion of the moved strip farther from the stream collapsing into the vacuity caused by the lurching.

---

<sup>1</sup> f. A. J. Cole, *Nature*, Jan. 14, 1897, vol. 55, pp. 254-256. G. H. Kinahan, *Nature*, Jan. 21, 1897, vol. 65, pp. 208-209.

<sup>2</sup> W. M. Conway, *Climbing in the Himalayas*. New York, 1894, pp. 118, 129-130, 323-324.

<sup>3</sup> T. G. Bonney, *Moraines and Mud Streams in the Alps*. *Geol. Mag.*, January, 11102, p. 8.

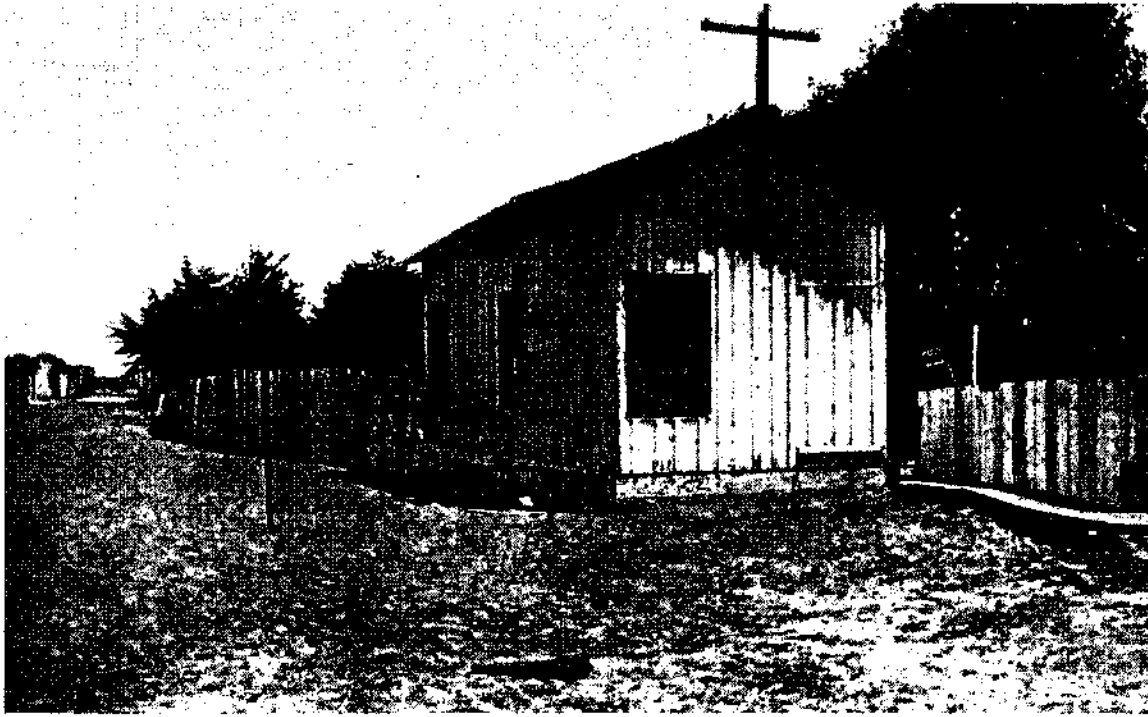

A. Moss Landing. Eonse, tree, and fence moved 12 feet by lurching of ground toward Salinas Eiver, A. 0. Li

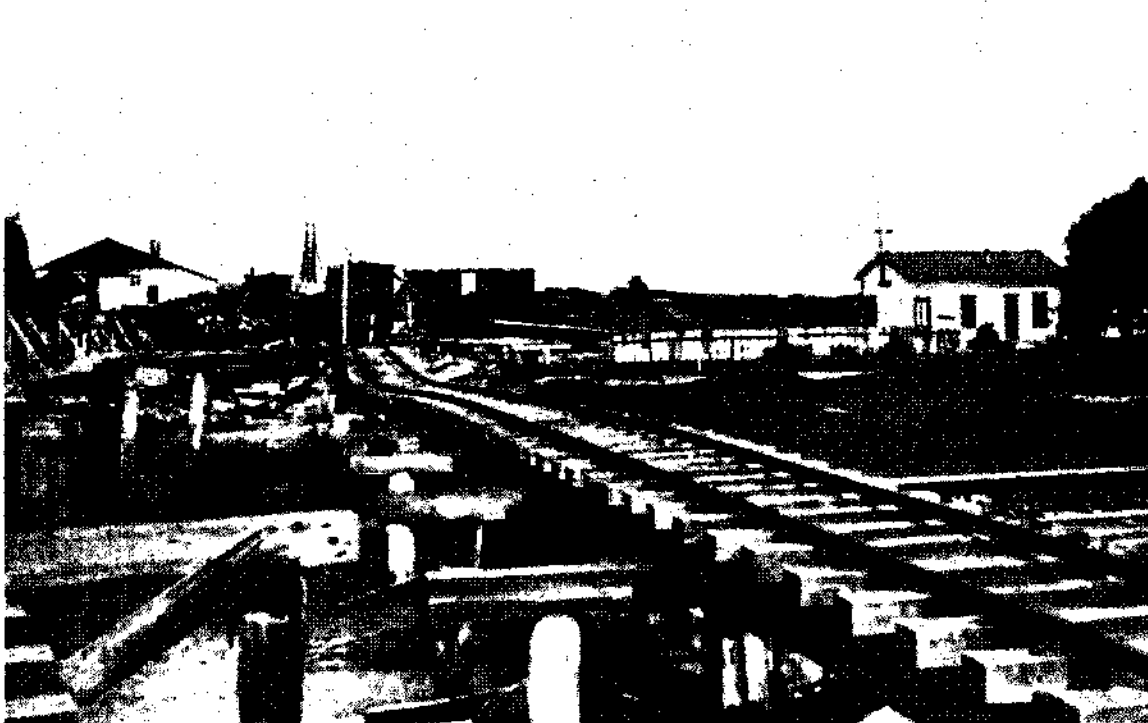

B. Mosa Laafiag. Larehiug of ground toward Saliaas Eirer carried piles fros beneath Ixiige timbers, casiig it to collapse. A. 0. 1.



A. Moss Landing. Inching of ground toward Salinas Eiver, to left, carried piles from "beneath bridge timbers and caused bridge to collapse. Displacement 9 feet. A. G. L.



B. Moss Landing. Deformation of surface due to Inching of ground toward Salinas Ei?er. A. O. L.



A. Lurohing of ground toward Salinas Eiver and consequent collapse. Near Spreokelsi Ai Cd Li



B. A detail of tisw shown ia A, A. 0. I<sup>8</sup>.



A. Lowering of ground toward Salinas River, with consequent collapse. Near Spreckels. Per J. O. B.



B. Destruction of road due to subsidence of ground toward Salinas River. H. K. Brown. A. C. L.

Along the beach, or sand-spit which separates the Salinas River from the Bay of Monterey at Moss Landing, there was a marked lurching of the spit toward the trench of the river as illustrated in plates 134A<sub>7</sub> B and 135A, B.

Lurching of soft ground was also exemplified on the tidal mud flats of Tomales Bay, and on the "made land" of San Francisco; but there being no trench in these cases, the movement caused a ridging of the surface with compensating depressions. In the case of the made land in San Francisco, and perhaps generally, the deformation of the surface due to lurching was complicated by the settling together of the loose material.

#### CRACKS AND FISSURES.

The cracks in the ground which appeared at the time of the earthquake fall into different categories. Of these there are two distinct classes:

1. The crack or fissure of the main fault, which is a superficial expression of the deep rupture of the earth's crust that caused the earthquake. Associated with this as a subclass are the auxiliary cracks and fissures which are superficial expressions of branch ruptures or subparallel ruptures, generally close to the main rupture in the Rift zone. In this class would also belong any cracks due to supplementary faulting in the general zone of disturbance, if such supplementary faulting exists, which is doubtful except in special instances.

2. The second general class includes those cracks and fissures which were caused by the earthquake, as a result of the commotion of the ground, and have, therefore, been designated as secondary.

The main crack, or fault-trace, and the auxiliary cracks satellitic to it, have been described in the section of the report dealing with the earth movement along the fault.

The secondary cracks, inasmuch as they are an indication of the intensity of the shock at any locality, have been described or referred to in the section dealing with the distribution of intensity. A brief review of the phenomena of cracks in the ground, apart from the main fault-trace and the auxiliary cracks in the Rift zone, will, however, be given, even at the risk of some slight repetition.

Since some of the cracks to be referred to can not with certainty be placed in one or the other of the two fundamental classes above indicated, it will be found convenient not to force that classification in all cases. Along the zone of the Rift there were many secondary cracks, as well as those classed as auxiliary; but it was not in every case possible to discriminate between them. These secondary cracks occurred both on hill slopes and in alluvial bottoms. On the hill slopes they were very commonly associated with landslides, or marked the inception of landslides; and these have already been discuss. On the bottom lands of streams or embayments in the Rift zone, cracks in the ground were exceedingly common for the entire length of that portion of the Rift along which the fault extended. In very many cases these cracks were associated with the lurching of soft incoherent materials, just as the cracks on the hillsides were associated with more common phases of landsliding. There were also, however, many cracks quite dissociated from the deformation of the surface due to lurching, although there was doubtless in these cases an ineffective tendency to lurching.

Beyond the zone of the Rift, cracks were observed at many localities. These were most common on the bottom-lands of the streams, notably the Eel River (plate 138A, B), the Russian River (plate 139A, B), Coyote Creek (plate 140A, B), and other streams at the south end of the Bay of San Francisco, Pajaro River (plate 14In), San Lorenzo River, and the Salinas River. Many other smaller streams might also be mentioned. In these cases the cracks were usually associated with the phenomena of lurching of the alluvial deposits, though many cracks *also* occurred where no such association was apparent. They were in nearly all cases found to be parallel or sub-parallel to the nearest

portion of the stream trench. They very commonly extended for several hundred feet, in some instances for several hundred yards, and were characteristically arranged in linear series. The cracks in the series in some cases overlapt *en échelon*, and in others they were in groups of parallel cracks in belts a few hundred feet wide. In no case was there any suggestion that they were more than purely superficial phenomena. A unique manifestation of surface cracks is that described by Matthes and Crandall in the vicinity of Livermore. (See plate 141A.)

On the hillsides and ridge crests, at points not within the Rift zone, cracks were of common occurrence. Most of these were connected with landslides, as has been indicated in the section dealing with that subject. Roadways and artificial embankments were particularly susceptible to damage from such cracks. But some of the cracks had no apparent connection with landslides, actual or incipient, and these are of especial interest. The most northerly are those described by Mr. E. S. Larsen in the region northwest of Covelo, Mendocino County, as set forth in the record of intensity. Some of the cracks described by Mr. Larsen cross the crests of rocky ridges; and altho it was not possible to follow them for great distances, they evidently extend down into the rock. It is remarkable that in the district where these cracks occur, there was no evidence of a local rise in intensity and, therefore, nothing to suggest that they were the seat of a supplementary local earthquake. The probable interpretation of the occurrence is that they are secondary cracks of a rather exceptional kind, in ground that required no very severe shaking to rupture it superficially. Cracks of a similar character were noted by Mr. C. E. Weaver in the Clear Lake district and on the flanks of Mount St. Helena.

On the San Francisco Peninsula, similar cracks were observed by Mr. R. Crandall on Cahill Ridge and Sawyer's Ridge, and are described by him in his account of the distribution of intensity in that region. In the Santa Cruz Mountains, such cracks were common and are, described more or less in detail in the section on the distribution of intensity. In general they appear to be the result of the earthquake rather than a contributory cause, although in some cases it is quite possible that they may have been local ruptures of the nature of auxiliary cracks and so gave rise to subordinate vibration.

## EFFECT OF THE EARTHQUAKE UPON UNDERGROUND WATERS.

### SIGNIFICANCE OF THE PHENOMENA.

Perhaps the most interesting and significant fact which the study of the earthquake has brought to light, apart from the great fault along the Rift, was the general disturbance of underground waters. In earthquakes generally, the phenomena which appear at the surface of the earth have become well known and, indeed, almost commonplace in recent years; but what transpires in the earth's crust below the surface, as the earth-waves generated at the seat of disturbance pass through it, is as yet a matter of uncertainty and inquiry. The effect of the shock upon the movement of underground water, as manifested by the behavior of springs and wells, throws light on this question. A few pages are, therefore, devoted to recording information of this kind.

It appears from the reports that have come in that springs and wells were very generally and variably affected throughout the disturbed area, indicating a sudden derangement in the normal movements of such water. This derangement could only have been effected by the changes in spaces in the rocks in which the waters in the subsurface region are contained, whether flowing or stagnant. These spaces are of 4 general kinds: (1) interstitial spaces, or so-called voids, between the constituent fragments of imperfectly compacted rocks, such as sands, gravels, sandstones, conglomerates, tuffs,



A. Eel Eiver, near Perndale, Oraolra in flood-plain, A. 8. E.



B. Eel Eivar, near Fsmdale, Orackn is led-plsla. A. 8. E.





A. Russian River west of Windsor, OrackB in flood-plain. E. S. H.



B. Bnaakn Ei?er. Orack in flood-plain parallel to river. E. S. H.



C. Fisaxuea in alluvium \ Tevis raioli, near Alma. I. H. S.



D. Upheaval of bottom of artificial lake; TeviB ranch, near Alma. I. H. S.



A. Secondary cracks in alluvium near Milpitas. Per J. O. B.



B. Secondary cracks in alluvium near Cimk. Per J. O. B.



A. Oenothera raoked in ground around an old alkaline spring, 1.5 miles north of Livermore. E. O.



B. Salvia raoked with dense foliage, in alkaline soil. W. A. W.

etc.; (2) the cracks and fissures which traverse the more firmly compacted forms of the same rocks, or others, such as granite, lava, etc., which occur only in a solid or coherent condition; (3) the vesicular spaces and tunnels of lavas, and (4) the spaces of dissolution which occur frequently in relatively soluble rocks, notably limestone. The occurrence of water which does not permeate the rocks nor flow thru them, but is contained in small discrete cavities in rocks, such as the liquid inclusions in igneous rocks and in the constituent minerals of sedimentary rocks, is here ignored. Thruout the Coast Ranges of California, limestones are not abundant and spaces of dissolution are believed to have played no part in the changes which were manifested in the behavior of springs and wells. The same remark holds with reference to vesicular and tunneled lavas. These changes were thus confined to the voids of porous and usually little coherent rocks and to cracks and fissures which traversed the coherent rocks, whether porous or not.

In the discussion of certain earth-flows in the preceding section of this report, the initiation of which is ascribed to a sudden accession of water from the underlying formations, attention has been already directed to an extreme phase of the disturbance of the normal conditions of the ground-water. In those cases the ground-water was suddenly expelled or squeezed out of saturated, incoherent formations at the time of the shock. They are extreme manifestations of a tendency which affected the ground water generally thruout the disturbed region. In this connection, it may be well to direct attention more particularly than has hitherto been done to the behavior of water contained in the alluvium of the river-bottoms. One of the most common phenomena in such situations was the expulsion of water in jets from apertures which suddenly appeared in the flat-lying ground. The water was usually thrown into the air for several feet; in some cases it was reported to be as much as 20 feet, and the ejection continued for several minutes after the earthquake. The continuance of the ejection after the shock indicates that an elastic stress had been generated in the saturated ground, which thus found relief in the expulsion of the contained water or that there was a gravitational settling together of the material, which diminished the spaces occupied by water. The vents thus established were very numerous, and were in many instances closely spaced; more frequently a few to the acre, and occasionally isolated. These vents were easily recognizable for weeks and even months after the earthquake, in the form of craterlets. The water in its passage to the surface brought up considerable quantities of fine sand, which, from its prevailing light bluish-gray color, was evidently derived from considerable depth. On the flood plain of the Salinas River, the sand was recognized by the people of the neighborhood to be the same as that of a stratum of sand pierced by wells at a depth of 80 feet. The craters were usually distinctly funnel-shaped and were rimmed by a circular flat ridge of sand which, by reason of its light color, was in marked contrast to the surrounding surface. They varied in diameter from 1 to perhaps 10 feet. In some instances the funnels were several feet deep; in others the feeble action in the closing stages of the eruption had caused them to fill up with sand. They were quite analogous to the craterlets described and pictured in Button's account of the Charleston earthquake.<sup>1</sup> (See plates 142A, B and 143A, B.)

These craterlets occurred on practically all the saturated alluvial bottoms of the streams within the zone of destructive effects, and also on the tidal mud flats of Tomales Bay. They are significant of the compression to which such water-laden, incoherent formations were subjected by the passage of the earth-waves at the time of the earthquake or by the consequent settling of the ground. They thus afford us, in part at least, a key to the behavior of many springs and wells. Most of the springs of the Coast Ranges are in solid rock, though they may emerge on a hillside mantled with rego-

<sup>1</sup> U. S. Geological Survey, 9th Ann. Report, pp. 296-298.

lith and soil. Such springs, as a general rule, had their flow increased at the time of the earthquake. The tendency to compression in firm rocks would not be so effective as in the case of noncoherent sediments, but it would make itself manifest in the generation of an elastic stress which would die out and merge with the normal gravitative stress very gradually. There would also be an effective tendency to bring together the walls of cracks and fissures whose planes lay transverse to the path of propagation of the compressive wave. Both of these tendencies would make for an expulsion of the water. The expulsion could not, in most cases, be effected suddenly, however, owing to the great frictional resistance; and simply resulted in an increased flow of the springs at the surface, which would continue during the life of the abnormal elastic stress. The duration of this stress appears in some cases to have lasted but a few days; in other cases it continued for 2 months, as inferred from the abnormally large flow of the springs. This variation would depend on local conditions, such as the superficial or deep source of the water, the character of the rocks, the degree to which it was seamed with cracks, etc.

This same general explanation would apply to artesian wells, in which the water acquired and maintained an increased head for some time. In some such wells, where the water stood normally at some little distance below the surface, it overflowed and flooded the ground in some instances. In other cases, where the supply was not artesian, but shallow wells reached the ground-water, the level of the latter rose. This general tendency was complicated in some instances by other effects of the earthquake. Several surface wells had their level lowered, and others went dry. This sudden drop in the level of the ground-water can be explained only by a sudden draining off of the underground waters to lower levels, and this might be effected by the opening up of the ground superficially, in consequence of the shock. A similar explanation would apply to the few springs which had their flow diminished or cut off altogether. This draining off of the waters of higher levels would also augment the flow of springs and wells at lower levels and may in some cases have been the principal cause of observed increases of flow. The noteworthy case of the spring near Ukiah, described below, which ceased flowing and remained dry thruout the following summer and fall, but resumed its flow with the advent of the winter rains, suggests that the fissure in the rock from which the spring welled served as the limb of a siphon and that the water in the siphon was drained off in consequence of the agitation and opening of the ground at the time of the shock. The winter rains refilled the siphon limb and so brought about a resumption of the flow.

One of the most common reports regarding the shallower wells was the roiling of the water by the admixture of earthy matter, doubtless due to the agitation of the ground and the loosening up of the incoherent material at the bottom of the wells.

#### RECORD OF SPRINGS AND WELLS AFFECTED.

A brief and partial record of springs and wells affected by the earthquake follows:

*Montague, Siskiyou County* (C. H. Chambers). — A sulfur spring was formed at a point 2 miles south of the town of Montague. Hot water ran from it for 2 days, after which it cooled off. A soda spring 9 miles east of the town doubled its flow. The water of many springs was muddy for several days after the quake.

*Denny, Trinity County* (P. L. Young). — At a small quartz mine near Denny the shock doubled the amount of water flowing from the tunnel.

*Peanut, Trinity County* (Mrs. E. Diller). — There was an increase in the water in the ditch which comes from a small gulch. The increased flow had not diminished up to May 6, 1906.

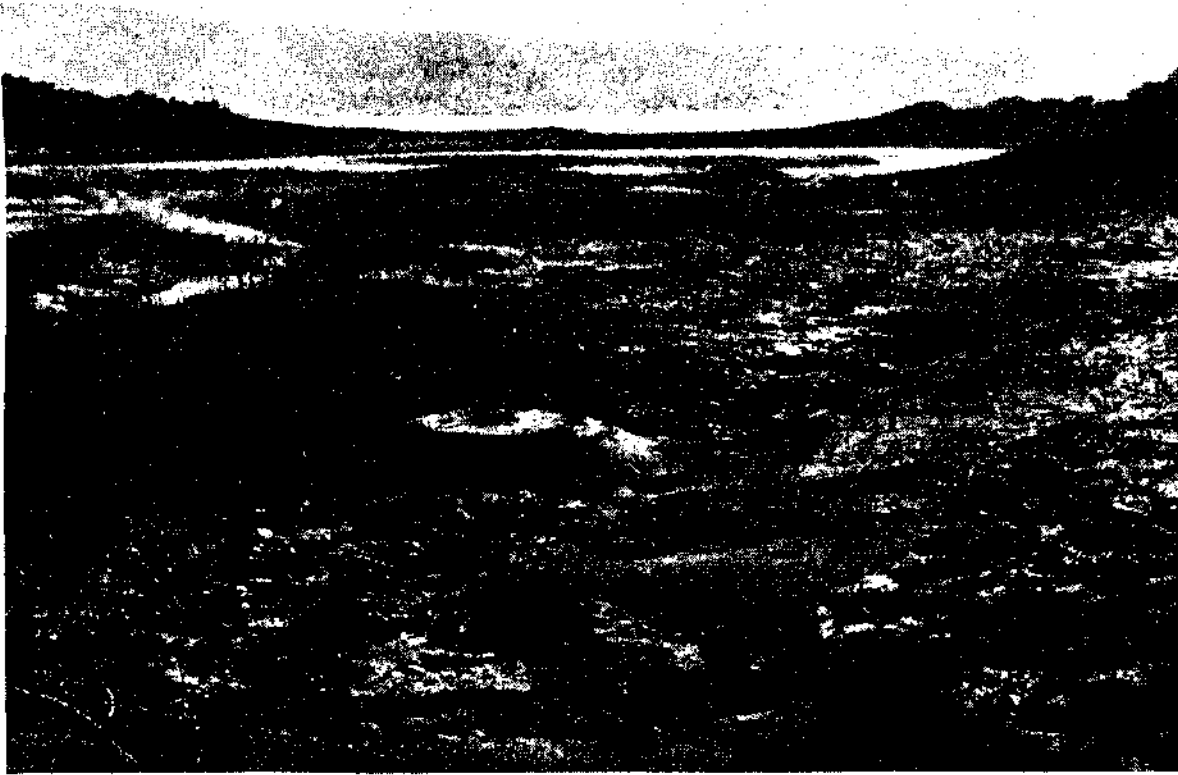

A. Oiatelets in sand near marsh east of Bodega Bay. J. N. L.



B. Oraterlets along fault-trace on sand spit at mouth of Tomales Bay. B. S. H.



A. Craterlets in fields near MilpitaB. Per J. O. B.



B. Craterlets near Watsom-fille. PerJ. C. B.

*Briceland, Humboldt County* (J. W. Bowden).—The pressure on the flow of natural gas was doubled in the vicinity.

*Covelo, Mendocino County* (E. S. Larsen).—Some springs and wells in the vicinity went dry, while others flowed more freely.

*Laytonville, Mendocino County* (A. S. Eakle).—A sulfur spring had its volume of water increased at least threefold by the shock, according to report.

*Mendocino, Mendocino County* (O. H. Ritter).—Wells in the lower part of town became full to overflowing and a heavy seepage of water was observed in the yard of the Alhambra Hotel.

(W. Mullen.)—The flow of a number of springs was increased.

*Ukiah, Mendocino County* (S. D. Townley).—The water in the well at the Observatory was very noticeably roiled for several days after the shock. The Ukiah press for April 27 reports some very marked changes in the flow of springs near Ukiah. A spring near the E. Clemens Horst Company's ranch, which supplied water for domestic and ranch purposes, stopt flowing after the earthquake. The ranch is about 2 miles north of Ukiah and a little west of the center of the valley, and the spring is in the foot-hills on the edge of the valley, nearly a mile to the west of the ranch. Pipes connected the spring with 2 tanks on the ranch, the spring having supplied the ranch with water for a great many years. The foreman, John Eldred, states that the day after the earthquake it was noticed that no water was flowing into the tanks from the spring. Investigation showed that the spring, which comes out of rock, was absolutely dry. Mr. Eldred and his men worked for two or three weeks, digging, drilling, and blasting, in the effort to regain a supply of water; but these efforts were futile and were finally abandoned. A well 75 feet deep was dug on the ranch and a wind-mill erected. Eldred went to the site of the spring several times during the summer and early fall, but there was no water. Upon going to the place in the early part of the winter, after the rains had begun, it was found that the spring was again flowing with a largely increased volume of water. He estimated that the flow was about doubled. The spring was still flowing with the increased volume on March 15, 1907.

*Hemlock, Mendocino County* (C. D. C. Bowen).—Some springs flowed more abundantly after the shock.

*Lake County* (C. E. Weaver).—At Highland Spring, in Lake County, none of the springs dried up, but one new soda spring was formed in the Franciscan rocks. The mineral springs in all parts of the county are reported to have increased in flow and number. The artesian wells in Scott's Valley, west of Lakeport, have diminished in flow, and several have stopt flowing. Many wells have dried up, but this was not confined to any particular locality or part of the county. The shock apparently had no effect upon the waters of the northern part of Clear Lake, nor upon the springs in that part of the district.

*Lakeport, Lake County* (J. Overholser).—The flow of many springs increased on account of the earthquake, while the flow of artesian wells decreased.

*Annapolis, Sonoma County* (G. W. Fiscus).—Wells and springs have gone dry in places, and water has come to the surface where there was none before.

*Sebastopol, Sonoma County* (R. M. Hathaway).—The wells in this vicinity wore all stirred up, the water becoming filled with sediment, as tho a heavy rain had washt in surface water. A small brook a little to the left of a fissure in the soil on the Blundon place had its flow of water so increased that the owner of the place had his attention called to it by the roaring of the water.

*Santa Rosa to Sonoma, Sonoma County* (E. S. Larsen).—At the city pumping station, 1.5 miles east of Santa Rosa, there are 4 wells, dug 50 feet and connected with a tunnel 450 feet long. Within each well there is a bored well 8 inches in diameter and 108 feet



deeper than the dug well. The water began to rise immediately after the shock, and is 15 feet higher than before, altho the pumps have been run to their full capacity.

The warm spring at Peters' ranch was little affected, except that for a day or so after the shock the water in the spring was lower. At Conrad ranch, northwest of Melita, there are numerous warm springs, about 100°, all along the base of a hill, which have had their flow increased very much. Mr. Striddle thinks that there is ten times as much water as before, and that it is a little warmer. He also tells me that the flow is gradually decreasing again. The springs at Melita, along the north side of the hill, have behaved much like those at Conrad's. I am told the creek about 2 miles to the north has risen considerably since the shock.

A mile north of Kenwood there is a well which was dried up about a year ago by an earthquake, and had to be dug deeper. This shock did not seem to affect it.

Glen Ellen Springs continue to be changed, usually increasing their flow, tho a few springs went dry. At McEwan's Ranch, 3 miles west, both cold and hot springs are flowing much more water. At the State Home at Eldridge, a warm spring started about 0.75 mile east of the town. Hot springs at Agua Caliente have nearly trebled their flow, and the temperature has risen from 112° to 114°. A spring which required pumping before now flows.

Boyes Hot Spring has increased a little and now flows without pumping. The temperature has also increased a little. Several years ago an earthquake stopt the flow, so that pumping has been required until this last shock. At Sonoma the wells and springs supplying the city are flowing more than before.

*Veterans' Home, Napa County* (A. Brown); — The earthquake caused the springs to flow more fully for about 2 months, after which they returned to normal.

*Napa, Napa County* (T. Hull). — In many cases springs increased their flow.

*Redding, Shasta County* (L. F. Bassett). — Some springs have been reported to have increased their flow and to have a lower temperature.

*McCloud River, Sliasta County (Chico Enterprise)*.—Springs in the limestone belt above Baird, which were formerly cold and clear, became warm and milky.

*Allegheny, Sierra County* (W. A. Clayton).—The earthquake changed the flow of water in mines and springs.

*Suisun, Solano County* (E. Dinkelspiel). — Mr. Miller's gas well, 3 miles northwest of Suisun, gave threefold greater volume of gas for 2 weeks before the earthquake than it did afterward.

*Martinez, Contra Costa County* (R. Wulzen). — Alhambra Creek is said to have risen 2 feet after the earthquake. A small stream to the east of the town, which is usually dry by May 1, now has considerable water. The same is reported of another stream south of town. A well in the vicinity, in which the water has always been several feet below the surface, is reported to be filled almost to the surface.

*Stockton, San Joaquin County* (R. Crandall). — An old disused gas well at the City and County Jail had a flow of water started in it by the earthquake. This flow continued for about two weeks, after which time it began to diminish. In a gas well, at the City and County Hospital, both the gas and water flow had been doubled and had continued so up to the time of my visit.

*Ripon, San Joaquin County* (T. H. Wren). — I have 18 acres of alfalfa land, which watered with an inch less water over the head-gate in 1905, in 17 to 20 hours. This year it took 25 hours to water 13 acres, all conditions being the same as last year except that the land was more packed and should have watered quicker. Others have made the same observation.

*Sunol, Atameda County* (R. Crandall). —The level of the ground-water around Simol was affected considerably. In most of the wells the water rose, some overflowing for

a short time. The postmaster gave 4.5 feet as the measured rise of the water in his well. The spring which furnishes the town supply is said to have been diminished by one-fourth of its flow. Two other changes in water supply were reported: one being the starting of a new spring near one of the western Pacific camps in Niles Canyon; the other the rejuvenation of an old sulfur spring near Sunol, which had not flowed for many years.

*Calaveras Valley, Santa Clara County* (G. F. Zoffman). —The springs near Mr. Robert Ingleson's house, in section 22 on the ridge east of Calaveras Valley, became muddy after the shock and remained so for two or three days. The volume of water discharged by the springs increased to about four times the usual amount.

*Alvarado* (E. W. Burr). — At the Alvarado Sugar Mill, in several wells, formerly flowing artesian wells, the water-table is now a few feet below the surface, the water-level having risen at the time of the earthquake. In the accompanying table are given the heights of water in a number of wells about the mill, referred to an assumed level 30 feet above an assumed base. These wells were observed daily before and after the earthquake. In most of them the water suddenly rose. The readings show that in a few cases the water rose from 1 to 2 feet. A well which used to be considered nearly dry began showing daily fluctuations, overflowing nearly every morning for some weeks after the earthquake.

The figures here given are for measurements made on April 9 and 14, preceding the earthquake of April 18, 1906, and the measurements made on April 21 and 28 of the same month, and May 5 subsequent thereto.<sup>1</sup>

*Heights of water referred to an assumed level 30 feet above assumed base.*

No. of Well.	Approx. Depth (feet).	April 9.	April 14.	April 21.	April 28.	May 5.
1	470	22.89	24.81	26.14	26.31	26.56
2	312	26.64	26.81	28.14	25.48*	28.23
3	318	26.22	25.47	28.05	27.97	27.30
4	402	26.62	26.87	28.37	28.20	28.28
5	405	26.67	28.17	28.34	28.25	28.42
6	402	26.70	28.28	28.37	28.03	28.45
7	399	26.79	26.87	28.45	28.04	28.45
8	45	26.79	26.87	28.45	28.04	28.45
9	544	25.36	25.36	26.69	26.94	27.19

\* No. 2, April 28. House pump was taking water from this well when measurement was taken.

*San Francisco Peninsula* (R. Anderson). — Thruout the central portion of the San Francisco Peninsula, the chief geological effects, aside from the actual displacement along the fault and the slumping and settling of alluvial ground, were the increased circulation of water and its discharge at the surface. The normal flow of water from springs was much disturbed. The water was usually muddy or milky. It is reported to have flowed salty from one spring for 2 days after the earthquake; after this it returned to its usual purity. Streams were considerably swollen temporarily, and water frequently came to the surface where it had not made its appearance before.

(R. Crarull.)—At Mr. Ebright's place, at the lower end of the lake in Pilarcitos Canyon, the spring water used for house supply is said to have been milky white the day of the earthquake. At Byrne's store, on the Half Moon Bay road, 0.5 mile west of Crystal Springs Lake, it was reported by the keeper that the water from their spring on the day of the shock was muddy and was not tasted; on the second day it had a very salty taste, and on the third day was again normal.

*Santa Clara Valley* (J. C. Brainier). —At Mcnlo Park, a mile nearer Fair Oaks Station, an artesian well flowed faster after the shock. At the Scale place, on the Embareadero

<sup>1</sup> Since the wells in this district fluctuate in level with the rise and fall of the tide in the bay, a correction would have to be made for this influence before the effect of the earthquake upon the underground water could be inferred from the figures given in the table. If the height which the level of the water in the wells was measured is known, the correction may be ascertained and applied at any time.

road, from the railway crossing at Palo Alto toward the Bay of San Francisco, a well was reopened. Other wells showed an increased flow and brought up sand. At Guth Landing, and southward along the road into Mountain View, the flow from bored wells had increased. A wind-mill which had for years pumped water from a well was no longer necessary, but the artesian water was muddy. At the Ynigo Ranch, 3 miles northeast of Mountain View Station, there was an artesian well which had, before the shock, flowed slightly or not at all, and a wind-mill was used to raise the water. After the shock it was found that the casing had been shoved up 2 feet, damaging the pump. The flow of water was increased, and black sand was brought up. Another well at this ranch was unaffected. Along the Jagel Landing road, 2 artesian wells had increased pressure after the shock. An old artesian well filled with stones had begun to flow for the first time in several years.

(H. H. Taylor.)—The water in an artesian well 215 feet in depth, near Millbrae, was roiled by the earthquake and remained so for several days.

*San Jose, Santa Clara County* (G. F. Zoffman). — Water and mud are reported to have spurted from many artesian wells.

(W. S. Prosser.)—A well near San Jose was reported as having increased in flow the day before the earthquake.

*Gilroy, Santa Clara County* (M. Connell). — It is reported on good authority that at Gilroy Hot Springs the temperature of the water rose nearly 10° and the flow increased to 5 times the usual volume.

*Bellvale, San Mateo County* (Miss L. E. Bell).—Some springs dried up and others broke out with a great gush of water, where no water had flowed before. An oil well from which tepid salt water, oil, and gas had been flowing since 1898 became suddenly dry and a similar flow began in another well 2,000 feet deep, at a distance of 600 feet to the east of the first well, where before nothing had been found.

*Wright, Santa Cruz County* (Miss F. Beecher). — Most of the springs are running with a greater flow since the earthquake; but the water in our well on top of the ridge sank rapidly to the level it usually holds in August. The water in all wells was very roily for some days.

*Summit Hotel, near Wright, Santa Cruz County* (H. R. Johnson). — The well at the summit, from which the Summit Hotel obtains its water, has its bottom on solid rock. After the shock the level of the water in the well rose 12 feet.

*Boulder, Santa Cruz County* (J. C. Branner).—At a sawmill near Boulder Creek, water stopt running from a hitherto permanent spring, but another in the neighborhood was flowing more freely than before.

*Felton, Santa Cruz County* (Miss F. Locke).—All the springs on the property of Miss S. Anderson, a mile east of Felton, greatly increased in flow.

*Soquel, Santa Cruz County* (W. E. Wheaton). — I have a drilled or bored well, yielding a magnificent flow of clear water. From three to four weeks previous to the earthquake this 75-foot well began to show signs of agitation below the surface. Every few days water heavily mixed with sand and ground chalk rock was pumped up. I knew that something was going wrong down under the earth, owing to the action of this well. When the quake came, it drove both fine and coarse sand into the casing, which put the well out of commission entirely.

*Chittenden, Santa Cruz County* (G. A. Waring). — Near Chittenden a marked increase was noted in the flow of oil and water, and more gas and sulfur appeared. In the neighborhood of Santa Ana Peak, the flow of springs was increased.

*Prunedale, Monterey County* (H. H. McIntyre). — Water started in many places where there had been little or none before the earthquake.

*Salinas, Monterey County* (G. A. Daugherty).—In many places water came up thru open fissures; in one place about 8 miles from Salinas, the water covered about 80 acres of land.

(B. M. Abbott.)—Water spouted from holes in the ground to a considerable height, and flooded the fields.

*San Ardo, Monterey County* (G. A. Waring). — At San Ardo, quicksand was thrown up in a well, seeming to lessen the flow considerably.

*Paraiso, Monterey County* (A. S. Eakle).—At Paraiso Springs, the quake affected the underground waters. According to the owner, Mrs. Romie, the supply of water from the springs had been diminishing for some time, and the temperature had been decreasing. Immediately after the shock it became necessary to put in a large pipe to carry off the water, and the temperature has resumed its normal state.

*Lonoak, Monterey County* (J. Rist). —The earthquake caused springs to flow more; and the water rose in some wells.

*San Benito Valley to San Joaquin Valley* (G. F. Zoffman). — In some places about 5 miles northwest of Bell's Station, on the Pacheco Pass road, springs were reported to be flowing 2 or 3 times as much water as they had previous to April 18. At a ranch-house 7 miles from the pass, on the east side of Pacheco Pass, the increase in the flow of water from springs in the neighborhood was said to have been noticeable. Springs were reported to have opened up considerably thruout the region around Emmet P. O.

*Stone Canyon, Monterey County* (G. F. Zoffman). — In the neighborhood of Stone Canyon Coal Mine, the people claimed that there was a sudden rise of the water of the wells immediately after the earthquake.

*Dudley, King's County* (O. D. Barton). — The gas spring on sec. 22, township 25 S., Range 18 E. was started into great activity by the earthquake. Formerly there were 7 places where gas could be seen occasionally blowing off through a shallow pool of water. Now there are more than 50 places where gas blows off continuously. The quantity of water was greatly increased. Beneath these gas springs the ground is dry and hot.

*Bakersfield, Kern County* (A. G. Grant).—Artesian wells 30 miles north of Bakersfield were rendered muddy by the earthquake.

*Gold, Madera County* (T. J. Rhodes).—Several springs increased about one-third to one-half in volume.

*Steamboat Springs, Nevada* (J. A. Reid). —At these springs the water is constantly boiling. For about 3 days after the earthquake, the volume was considerably increased, and the water became noticeably turbid with mud. On the north end of the highest sinter terrace, where heretofore the waters had been invariably clear, considerable quantities of mud were discharged. This material is now lying dry on the white surface of the sinter and is gradually being blown away. At the extreme north end of the active springs, where several mud springs have always existed, the change was noticed in the increased activity. One in particular formed a low cone of dark-colored mud, which is now dried and cracked.

RECOBI) OF AFTER-SHOCKS.

The list of after-shocks given below has been compiled by A. O. Leuschner from all reports that have come to hand. These reports include not only communications in answer to the three circulars sent out, but also other reports by interested observers. In addition many shocks in the list were taken from the separate reports printed in this volume. For the sake of completeness the shocks reported by Prof. Alex. McAdie in his monthly reports of the California Section of the Climatological Service of the Weather Bureau have also been included. A number of shocks have been inserted in the first proof from Prof. Alex. McAdie's Catalogue of Earthquakes on the Pacific Coast 1897-1906.<sup>1</sup> It should be stated, however, that this list by no means represents a complete enumeration of all after-shocks felt in California since April 18. In general, it may be said that the list becomes increasingly incomplete with the lapse of time since the great earthquake. This is particularly due to the efforts made by some of the newspapers to suppress all news regarding earthquakes in California. The list may be considered complete only for Berkeley, California, where several observers have endeavored to record every shock. As a rule the observer's name is included in the last column, initials being used for observers who have reported more than one shock. A key to the initials is given at the end of the list. The times are expressed in Pacific Standard Time.

Record of aftershocks.

Day.	Beginning of shock.	Duration.	Intensity.	Locality.	Remarks.
Apr. 18, a.m.	h. m. s.	secs.			
	S 18 57....	6 .....	IV	Berkeley.....	S. A.
	5 19 .....	2 .....	III	San Francisco....	A. G. McA.; J. G. P.
	5 19 10....	.....	III	do .....	Feeble, A. G. McA.
	5 21 .....	2 .....	III	do .....	Feeble, A. G. McA.; J. G. P.
	5 21 54....	3 .....	III	Berkeley.....	A. G. McA.
	5 22 .....	.....	III	Eureka.....	Northwest-southeast followed by a side cross-motion. Persons in beds resting east-west not awakened, A. H. B.
	5 25 54....	4 .....	III	Berkeley.....	S. A.
	5 20 .....	.....	.....	San Francisco....	Feeble, A. G. McA.
	5 27 .....	2 .....	III	do .....	J. O. P.
	5 28 Hi....	2 .....	II	Berkeley.....	S. A.
	5 28 19....	1 .....	II	do .....	
	5 30 .....	.....	.....	Humboldt. Lt. Stn.	
	5 34 40....	.....	II	Berkeley.....	S. A.
	5 35 (11)....	1 .....	II	do .....	S. A.
	5 37 39....	.....	II	do .....	S. A.
	5 39 32....	.....	II	do .....	S. A.
	5 43 .....	3 .....	IV	San Francisco....	Feeble, A. G. McA.; J. G. P.
	5 43 50....	3 .....	III	Berkeley.....	Two separate jerks, S. A.
	5 48 .....	.....	II	Phoenix (Ariz. I) ..	Slight. West to east.
	5 59 13....	.....	.....	do .....	S. A.
	6 00 .....	.....	.....	San Maten Point..	
ti (Hi)....	.....	.....	San Francisco....	Light, N. E.	
0 10 30....	7 .....	III	Berkeley.....	2 max., one at 35 s., one at 41 s., S. A.	
ti 2S 13....	2 .....	II	do .....	S. A.	

<sup>1</sup> Smithsonian Miscellaneous Collections, part of vol. XLIX.

RECORD OF AFTER-SHOCKS.

Record of after-shocks — Continued.

Day.	Beginning of shock.	Duration.	Intensity.	Locality.	Remarks.
Apr. 18, a. m.	<b>h. m. s.</b>	<b>secs.</b>			
	6 30			San Francisco	Light, N. E.
	6 30 +		I-II	Mt. Hamilton	R. G. A.
	6 42			San Francisco	Light, N. E.
	6 44 11	6	II-	Berkeley	S. A.
	6 45			Mt. Hamilton	R. G. A.
	6 46 34		II	Mt. Hamilton	K. B.
	6 50		IV	Scott's Valley	F. L.
	6 52		IV	do.	F. L.
	6 56				San Francisco Light, N. E.
	7 00			Cloverdale	Slight shock about 7 a. in.
	7 07		IV	Scott's Valley	F. L.
	7 20			Sausalito	
	7 30		IV	Scott's Valley	F. L.
	8			Sacramento	Slight shock soon after 8 a. m.
	8 02	2		Bonita Pt. Lt. St.	Nearly vertical; toward NW.; no tremor, just a jar; 1 max. strongest at beginning; no clock stopt, no sound.
	8 07			Yerba Buena	Light.
	8 10			Mile Rocks	Smart
	8 12	1-2		Mare Island	Slight shock.
	8 13			Antioch	
	8 14 14	10	IV-V	Berkeley	Was looking at watch when shock began, S. A.
	8 14 27		IV-V	do.	At Students' Observatory, A. O. L.
	8 14 28 <sup>h</sup> to 8 14 33			San Francisco	Sharp twisting motion, A. G. McA.
	8 14 39		II	Mt. Hamilton	A. M. H.
	8 14 45	3		Sacramento	
	8 15			Alcatraz	
	8 15	5		Oakland	
	8 15			Yountville	Severe.
	8 15	1	V	Mile Rocks	Strongest at middle, sound like cannon shot, following beginning 1 s. Sharp.
	8 15	2	V	San Francisco	
	8 18	4	III	do.	
	8 19			do.	N. E.
	8 19 20	5	V	Oakland	Northeast to southwest; 15 additional shocks by 1 p. in., duration 2-5 s., cast to west, III-IV. 3 shocks between 1 and 3 p.m. 5 shock between Apr. 18, 3 p.m., and Apr. 19, 6 a. in.
	8 20		IV	Scott's Valley	F. L.
	8 25		IV	do.	F. L.
	8 30		II	Tuolumne	About X <sup>1</sup> 30" a.m.
	8 30			Stockton	Very light.
	8 42			San Francisco	N. E.
	8 55		IV	Scott's Valley	F. L.
	8 58		IV	do.	F. L.
9 14			do.	Sharp and short, A. G. McA.	
9 16 52		III	San Francisco	K. B.; A. M. H.	
9 17		IV	Mt. Hamilton	F. L.	
9 19		IV	Scott's Valley	F. L.	
9 20	1-2		do.		
9 22		IV	Scott's Valley		
9 26			Mare Island	Moderate, A. G. McA.	
9 26 10	2	II	San Francisco	S. A.	
9 26	2		Berkeley		
9 28	2	III	San Francisco		
9 30	20		Southampton Shoals	N.-S. Horizontal tremor 10 s. before, 1 sharp shock, nuub.	
9 30			Mt. Hamilton	One other between 1 <sup>h</sup> 4 <sup>m</sup> and 8 <sup>h</sup> 1 <sup>m</sup> . H. G. A.	
9 32	1		Scott's Valley	F. L.	
9 35	ISO		do.	F. L.	

## Record of aftershocks—Continued.

Day.	Beginning of shock.	Duration.	Intensity.	Locality.	Remarks.
Apr. 18, a. m.	h. m. s.	secs.			
	9 40.....	1.....	.....	Scott's Valley.....	F. L.
	9 48.....	.....	.....	do.....	F. L.
	9 48.....	.....	.....	San Francisco.....	N. E.
	9 51 55.....	.....	.....	Berkeley.....	Ewing seismograph by R. T. C. and S. E.
	9 54 30.....	1.....	III	San Francisco.....	
	10.....	.....	.....	Lakeport.....	Slight (about 10.-).
	10.....	.....	.....	Oakland.....	
	10.....	.....	.....	Upper Lake.....	Not very perceptible, but stopt some clocks.
	10 04 39.....	10.....	IV	Ukiah.....	Increasing intensity with principal disturbance near middle of series. No clock stopt, S. D. T.
	10 05.....	.....	IV	Cloverdale.....	Oscillatory motion east-west.
	10 05.....	.....	.....	San Francisco.....	N. E.
	10 05 47.....	.....	.....	Point Reyes.....	Two distinct vibrations from north to south.
	10 05 50.....	.....	.....	Farallones.....	Felt by Mr. Legler at Pt. Reyes, with whom I was talking over telephone at the time, about 3 s. before felt in Farallones. J. A. Boyle.
	10 06 29.....	.....	.....	Berkeley.....	Ewing seismograph by R. T. C. and S. E.
	10 07.....	1.....	II	San Francisco.....	
	10 22.....	.....	.....	Scott's Valley.....	Slight tremor, followed in about 30 s. by hard shake of several seconds. Fully the fifth hard shake since 5 <sup>h</sup> 13 <sup>m</sup> , F. L.
	10 30.....	.15.....	.....	Southampton Shoal	West-east. Apparent direction east. Tremor 5 s. after first shock, no noise.
	10 36.....	1.....	II	San Francisco.....	
	10 50.....	.....	.....	do.....	Moderate, A. G. McA.
	10 50 30.....	1.....	II	do.....	
	11.....	.....	.....	Scott's Valley.....	F. L.
	11 00.....	.....	.....	S. F. Peninsula.....	Distinctly felt on ground and caused falling of loose parts of buildings.
	11 06.....	.....	.....	San Francisco.....	Moderate, A. G. McA.
	11 06 23.....	.....	.....	Berkeley.....	Ewing seismograph by R. T. C. and S. E.
	11 06 27 + 2	.....	.....	do.....	Students' Observatory, A. O. L.
	11 07.....	.....	.....	Antioch.....	
	11 08.....	4.....	III	San Francisco.....	
	11 12.....	.....	.....	Scott's Valley.....	Longer than usual, F. L.
	11 15.....	2.....	.....	Bonita Point.....	Nearly vertical.
	11 22.....	60.....	.....	Scott's Valley.....	F. L.
	11 36 "66" 1.1**	30.....	III	Ukiah.....	Southwest-northeast. No clock stopt, S. D. T.
	11 39.....	.....	III	Cloverdale.....	Oscillatory motion.
11 40.....	.....	.....	Upper Lake.....	Caused some clocks to stop; not all.	
11 47.....	.....	.....	San Francisco.....	Moderate, N. E.	
11 53 34.....	.....	II	Mt. Hamilton.....	A. M. H.	
11 53 37.....	.....	III	do.....	Vertical, K. B.	
Apr. 18, p. m.	12 03.....	.....	Oakland.....	Harbor Lt. St'n, Alameda Pier.	
	12 03.....	.....	San Francisco.....		
	12 03 43.....	.....	Berkeley.....	Ewing seismograph by R. T. C. and S. E.	
	12 03 44.....	2.....	II+	do.....	Faculty Club, S. A.
	12 03 52.....	.....	.....	do.....	B. L. N.
	12 04.....	4.....	III	San Francisco.....	A. G. McA.
	12 11.....	.....	.....	do.....	Very light, A. G. McA.
	12 13.....	3.....	"*Y	do.....	A. (J. McA.
	12 25.....	.....	.....	Eureka.....	Slight and of short duration, A. H. B.

Record of after-shocks — Continued.

Day.	Beginning of shock.	Duration.	Intensity.	Locality.	Remarks.	
	h. m. s.	secs.				
Apr. 18, p.m.	12 31	.....	III	Los Angeles	F. L.	
	1 02	.....	.....	Scott's Valley	F. L.	
	1 55	4	II	San Francisco	F. L.	
	1 57	.....	.....	Scott's Valley	Slight. Four miles south of Wright's Station.	
	2	.....	.....	Wright's Station	A little before 2 p. m.	
	2	.....	15	IV	S. F. Peninsula	Vertical throw north-south tremor 20s. before; no noise.
	2 15	.....	.....	.....	Humboldt Lt. Sta.	Very light.
	2 20	.....	5	.....	Southampton Shoal	F. L.
	2 20	.....	.....	.....	Stockton	Slight.
	2 20	.....	.....	.....	Scott's Valley	F. L.
	2 22	.....	1-2	.....	Mare Island	Slight.
	2 23 40	.....	.....	" II "	Mt. Hamilton	Very light, A. G. McA.
	2 24	.....	.....	.....	San Francisco	Ewing seismograph, R. T. C. and S. E.
	2 24 37	.....	.....	.....	Berkeley	
	2 25	.....	4	III	San Francisco	
	2 25	.....	.....	.....	Salinas	
	2 25	.....	.....	.....	Los Gatos	I. H. S.
	2 25	.....	.....	.....	Oakland	Alameda Pier.
	2 27	.....	1-2	.....	Mare Island	Slight.
	2 28	.....	.....	.....	San Francisco	Very light, A. G. McA.
	2 28 36	.....	.....	III	Mt. Hamilton	A. H. M.
	2 28 50	.....	.....	.....	Berkeley	B. L. N.
	2 29	.....	.....	.....	Sacramento	Very light.
	2 30	.....	.....	.....	Ajntioch	
	2 30	.....	.....	IV	Scott's Valley	Extra hard, stopt clock hanging on wall facing south, 20" pend. Stopt clock facing NW. by WNW., pend. about 5", F. L.
	2 30	.....	.....	.....	4 miles south of Wright's Station	Slight.
	2 30	.....	.....	VI	Ukiah	Stopt clocks (counted 35 shocks up to April 30), S.D.T.
	2 30	.....	4	III	San Francisco	
	2 30	.....	.....	.....	Salinas	
	2 32	.....	.....	.....	Los Gatos	I. H. S.
	2 35	.....	5	III	San Francisco	
	2 35	.....	.....	VI	Ukiah	
	2 35	.....	.....	III-IV	Scott's Valley	Extra hard, F. L.
2 40	.....	.....	.....	Salinas		
2 43	.....	.....	.....	Scott's Valley	Lighter, F. L.	
2 50	.....	.....	.....	do.	Lighter, F. L.	
3	.....	.....	V	Los Gatos	Little if any vertical movement. A muffled sound, like distant blasting heard in a mine, was noticed just preceding minor shocks which followed, including that about 3 p. m., I. H. S.	
4 26	.....	10	IX-X	Raleigh	Three shocks.	
4 28	.....	15	.....	Ballast Point	Vertical prop. SE. Increasing in intensity, strongest at middle. Clock stopt at 4 <sup>h</sup> 25 <sup>m</sup> 15 <sup>s</sup> pend, 18", facing E.	
4 28	.....	.....	.....	Teinemhi		
4 29 45	.....	20	IV-V	San Diego	Northwest and southeast. Strongest apparently at beginning. Clock not stopt, but disturbed, losing about 1 m.; pend. about 26". No sound phenomena.	
4 30	.....	.....	.....	San Diego	Heaviest in 15 years, northeast-southwest.	
4 30	.....	.....	II	Ramna	A few seconds.	
4 30	.....	.....	III	San Bernardino	Southeast.	



## Record of after-shocks — Continued.

Day.	Beginning of shock.	Duration.	Intensity.	Locality.	Remarks.
Apr. 15, p.m.	h. m. s.	secs.			
	4 30.....	.....	.....	San Juan Capistrano	Slight.
	4 30.....	.....	.....	Hemet, Riverside.	Shock increasing and dying away.
	4 30.....	.....	.....	Yuma (Ariz.)	9 or 10 distinct shocks, slight rolling from east to west.
	4 30.....	.....	IX	Brawley.	Northwest-southeast chimneys fell to west. Movable objects in bldgs., thrown west-east. Oscillation followed by tremors. Clock stopt at 4 <sup>m</sup> 30 <sup>m</sup> , facing south.
	4 30.....	Few ..	.....	Ballast Point.	North-south. Horizontal. Clock stopt 4 <sup>m</sup> 30 <sup>m</sup> , facing NW., pend. 17".
	4 50.....	.....	.....	Oakland	Alameda Pier.
	4 50 38.....	1.....	.....	Berkeley	Two tremors within 1 s., B.L.N.
	4 51.....	.....	.....	San Francisco	Very light, A. G. McA.
	4 52.....	.....	.....	Yerba Buena	Light.
	6 02 12.....	2.....	II	Berkeley	S. A.
	6 03 04.....	1.....	II	do.	S. A.
	6 12.....	.....	.....	Yerba Buena	Light.
	6 45.....	.....	.....	Antioch	
	6 50.....	.....	.....	San Francisco	Very light, A. G. McA.
	6 50.....	5.....	.....	Southampton Shoal	North-south. Horizon direction south, two light shocks, rumbling following shock 2 s.
	6 50.....	.....	.....	Oakland	Alameda Pier.
	6 51 29.....	8.....	IV	Berkeley	Faculty Club, S. A.
	0 51 35-45.	.....	.....	do.	Slight tremors during interval, B. L. N.
	6 51 58.....	.....	1-II	Mt. Hamilton	
	6 51 58.....	.....	II	do.	Vertical, K. B.
	6 52.....	.....	.....	Sacramento	Very light.
	6 53.....	.....	.....	Yerba Buena	Light.
	Sunset.....	.....	.....	Angel Island	Strong, rumbling.
	7.....	1-2 ..	.....	Mare Island	Slight.
	7.....	.....	.....	Stockton	Very light. Number of light shocks reported for several days, but hardly perceptible.
	7.....	.....	.....	Scott's Valley	Lighter, F. L.
	7 01.....	.....	.....	San Francisco	Very light, A. G. McA.
	7 23.....	.....	.....	Yerba Buena	Light.
	7 25.....	.....	.....	Scott's Valley	Lighter, F. L.
	9 10.....	.....	.....	do.	Lighter, F. L.
	9 43.....	.....	.....	do.	Lighter, trembling of house kept up for 2 m. or more, F. L.
	10.....	.....	.....	Lakeport	Light, about 10 o'clock.
10 35.....	.....	.....	Scott's Valley	Sharp shock, rather long. Trembling of house kept up for 2 m. or more, F. L.	
11 10.....	.....	.....	do.	Trembling of house kept up for 2 m. or more, F. L.	
11 22.....	.....	.....	do.	Light shock, F. L.	
Apr. 19, a.m.	1 30.....	.....	.....	Paisley, Oregon.	Tremor.
	3.....	20.....	.....	Eureka	Slight, A. H. B.
	3 07 00.....	.....	.....	San Francisco	Light, A. G. McA.
	5 22.....	.....	.....	Eureka	Slight and of short duration.
	5 07.....	23.....	.....	Eureka	Slight, A. H. B.
	6 25 10-1.....	3.....	III	Berkeley	Time is from memory, failed to record shock at time, S. A.
	.....	2-5 ..	11-111	Oakland	Seven shocks between 6 a. m. and 2 <sup>h</sup> 15 <sup>m</sup> p. in.
10 30.....	27.....	.....	Eureka	Slight, A. H. B.	
Apr. 19, p.m.	12 31 00.....	20-30..	.....	Los Angeles	Inm-ased intensity, 1 max., strongest at middle No sound.
	12 31 41.....	.....	.....	do.	

RECORD OF AFTER-SHOCKS.

Record of after-shocks — Continued.

Day.	Beginning of shock.	Duration.	Intensity.	Locality.	Remarks.	
Apr. 19, p. in.	h. m. a.	secs.				
	12 33			Los Angeles	Two shocks about 6 m. apart followed by slight tremors for about 1 h.	
	12 25	15		San Pedro	Horizontal tremors 10 s. before, increased intensity, strongest at end. No sound.	
	1 13			San Francisco	Sharp, main portion with twist, A. G. McA.	
	2 05			Reno, Nevada		
	3 +			Salinas	Another shock later.	
	3 25			Sacramento	Seemed to be north and south.	
	8 15-8 30		III IV-V	Hagen, Wadsworth, etc.	On east slope of Virginia Range, Sierra Nevadas; northwest-southeast. During next 1.5 h. 3 more, G.D. L.	
	10 45		III	S. F. Peninsula	Slight.	
	10 55			Laurel Glen	Tremor with 2 sharp after-shocks.	
	11 06			Yerba Buena	Light.	
Apr. 20, a. m.	11 10	30		Mile Rocks Kureka	Slight shocks during day. A. H. B.	
	12 30	2		Southampton Shoal	Vertical; direction upward. Tremor, 5 s. after; 2 sharp shocks, cracking sound coincident.	
	12 30 53			Ukiah	Shock too light to be felt. It was detected by motion of bubbles of latitude levels. The oscillation was 1 or 1 division (N. and S.) $d = 1.0''$ , S. D. T.	
	3	3		Eureka	South-north, slight.	
	4 45 00			San Francisco	Tremor, A. G. McA.	
	4 50			Napa		
	5			Laurel Glen	Short and sharp.	
	5 31			San Francisco	Moderate, A. G. McA.	
	6 10	3		Mile Rocks	Moderate.	
	7	3		do	Vertical. Strongest at middle.	
	7 13			Laurel Glen	Short and sharp.	
7 15			San Francisco	Moderate, A. G. McA.		
11 30			Tuolumne	About 11 <sup>h</sup> 30 <sup>m</sup> a.m.		
Apr. 20, p. m.	12 33		III	Santa Monica	North-south. Time not accurate.	
	2 30			Laurel Glen	Light.	
	5 26	10	IV	S. F. Peninsula		
	5 49	3	III	do	Followed after 4 s. by another brief motion.	
	8 23	15	III	do	Series of gentle tremors.	
	8 28			Scott's Valley	Light but decided, F. L.	
	9 03			do	Barely felt, F. L.	
	10 26			do		
				Mile Rocks	Slight shocks during day.	
	Apr. 21, a. in.	3			Napa	W. H. M.
		4 4			Scott's Valley	F. L.
5 28				San Francisco	Strung, A. G. McA.	
9 05				Scott's Valley	F. L.	
1 35		7	IV	S. F. Peninsula	Shaking houses 7 s. and repeated after "> s.	
3 15		5		Mure Island	T. J. J. See.	
8 27				Scott's Valley	F. L.	
Apr. 22, a. m.				Mile Rocks	Slight shocks during day.	
	2 or 2 30 4 45			Felton Scott's Valley	Two shocks; barely separated, but running fully 5 s., each a good shake, not wven. but slightly, on the latter. L.	

## Record of after-shocks—Continued,

Day.	Beginning of Shock.	Duration.	Intensity.	Locality.	Remarks.
Apr. 22, a. in.	h. m. s.	secs.			
	5 00.....	1.5..	.....	Mile Rocks.....	Slight.
	6 58.....	.....	.....	Scott's Valley....	Two shocks barely separated, last continuing fully 5s.; each a good shake, not severe but steady, oscillating, F. L.
	7.....	3.....	.....	Mile Rocks.....	Moderate.
	7 03 00....	.....	.....	San Francisco	Light, A. G. McA.
Apr. 22, p. m.	7 10.....	.....	.....	Scott's Valley....	A mere jolt, F. L.
	11 30.....	.....	.....	Saratoga.....	Described as underground explosion, about 11 <sup>h</sup> 30 <sup>m</sup> a. m.
	3.....	.....	.....	Napa.....	W. H. M.
	3.....	3.....	.....	Mile Rocks.....	Moderate.
	3 17.....	2.....	.....	Bonita Point.....	Nearly vertical. Direction NW.; no tremor, just a jar, 1 max., strongest at beginning. No sound, may have been blasting.
	3 18 20....	60+...	III	Berkeley.....	Tremulous motion for 5 m. after shock. Long duration of trem. motion also observed by Mr. Huber, who was in laboratory at time, weighing chemicals, S. A.
	3 18 22....	2.....	III	Oakland.....	C. B.
	3 19.....	.....	.....	Yerba Buena.....	Light.
	3 19 30....	4.....	.....	San Francisco....	Moderate rocking, about four waves, A. G. McA.
	Apr. 23, a. m.	8 35.....	.....	.....	Salinas.....
9 08.....		2.....	.....	Mile Rocks.....	Slight.
10 40.....		.....	.....	Salinas.....	
11 20.....		.....	.....	Scott's Valley....	Tremor, F. L.
12 05 00....		3.....	.....	San Francisco....	A. G. McA.
12 48.....		8.....	.....	Trinidad Head....	East-west tremor 5 s. before, short and heavy; clock stopt 12 <sup>h</sup> 48 <sup>m</sup> a. m., facing east; sound like thunder, preceded and continued during shock; same throughout, no change.
12 55.....		8.....	.....	Cape Mendocino..	Vertical. Southwest-northeast. Direction NE. increasing intensity. Clock stopt. Pend. 22", facing SW. No sound.
1 10.....		.....	.....	Grant's Pass, Ore.	
1 10.....		14.....	V-VI	Eureka.....	South-north. Stopt clocks, A. H. B.
1 11.....		10.....	.....	Ferndale.....	Severe shock, J. A. S.
1 12.....		.....	.....	Scott's Valley....	Light and short, but decided, F. L.
1 15.....		.....	II	Crescent City....	West-east.
1 16.....		.....	.....	do.....	South-north. Woke up everybody, no damage.
Apr. 23, p. m.	1 17.....	.....	.....	Cape Mendocino..	
	3.....	.....	.....	Scott's Valley....	"Just enough to waken me," F. L.
	6 07.....	4.....	.....	Eureka.....	South-north. Slight,
	6 30.....	3.....	.....	Ferndale.....	Severe shock, J. A. S.
	8 10 10....	3.....	III	Salinas.....	
	8 10 10....	3.....	III	Oakland.....	From east, C. B.
	9 15.....	4.....	.....	Mile Rocks.....	Moderate.
	12 45.....	.....	.....	Scott's Valley....	Barely perceptible, F. L.
	12 48.....	.....	.....	do.....	Very light, F. L.
	12 50.....	.....	.....	do.....	More decided, F. L.
2 50.....	30.....	.....	do.....	Decided trembling lasting perhaps 30 s., F. L.	
3 51.....	1.....	.....	San Francisco....	Sharp, downward jolt, A. G. McA.	
5 30.....	.....	.....	Salinas.....		

## Record of after-shocks—Continued.

Day.	Beginning of shock.	Duration.	Intensity.	Locality.	Remarks.
Apr. 23, p. m.	h. m. s.	secs.			
	5 45.....	3-4. ..	.....	Scott's Valley ....	Sharp, lasting 3 to 4 s., F. L.
	10 00.....	.....	III	S. F. Peninsula...	About 10 p.m.
	10 25.....	2.....	.....	Mile Rocks.....	Moderate, 2 max.
	10 34.....	.....	.....	San Francisco....	Moderate, A. G. McA.
	10 36.....	2.....	.....	Bonita Point.....	Nearly vertical. Direction NW., no tremor, just a jar, 1 max. strongest at beginning. No sound, may have been blasting.
	10 38 42....	6.....	IV	Berkeley.....	2 separate shocks, 2d stronger, S. A.?
	10 38 44....	.....	.....	do.....	2 separate shocks, 2d stronger, E. Smith.
	10 38 57?...	.....	III	do.....	Short and sharp. Northeast southwest. Tremulous mo- tion for 6 in. In bed awake, but watch correction uncer- tain, R. T. C.
	10 39.....	3.....	.....	San Francisco ....	East-west.
10 55.....	.....	II	Oakland.....	C. B.	
Apr. 24, a. m.	1 25.....	.....	.....	San Francisco ....	Short, A. G. McA.
	1 32.....	.....	.....	do.....	Tremors, A. G. McA.
	9.....	.....	.....	do.....	Doubtful, A. G. McA.
	5 46.....	.....	.....	Salinas.....	
	10 15.....	95 in. ..	.....	Berkeley.....	Slight continuous trembling, S. A.
Apr. 24, p. m.	1 14.....	.....	.....	San Francisco ....	Light throw, A. G. McA.
	4 45.....	75 m. ..	.....	Berkeley.....	Slight continuous trembling, S. A.
	8 10.....	.....	.....	Mile Rocks.....	Slight.
	10.....	60 m. ..	.....	Berkeley.....	Slight continuous trembling, S. A.
	10 45.....	.....	.....	Oakland.....	
	11 30.....	.....	.....	Berkeley.....	Reported by several. Mr. Wood also reports shock fol- lowed by unsteadiness of ground for over 1 h., S. A.
	11 42.....	.....	.....	Oakland.....	
Apr. 25, a. in.	1 26.....	3.....	.....	Berkeley.....	Light shock, lasted about 3 s. after awake, S. A.
	4 30.....	.....	.....	San Francisco ....	A. G. McA.
	6 30 22....	3.....	III	Oakland.....	Northeast to southwest, C. B.
Apr. 25, p. m.	12.....	.....	V	Mills College ....	Many small shocks.
	12 40.....	.....	III	Cloverdale.....	
	3.....	.....	.....	Mile Rocks.....	Slight.
	3.....	1.....	V-VII	Cliffs about Wood's Gulch..	
	3 12.....	2.....	V	Bonita Point....	Direction NW., no tremor, just a jar, 1 max. strongest at beginning, no sound, may have been blasting.
	3 15.....	15.....	V	S. F. Peninsula...	Strongly felt on ground, caus- ing landsliding along coast cliffs, lasting 10 s. with a slight repetition after 10 s.
	3 15.....	3.....	III	Oakland.....	C. B.
	3 15.....	.....	.....	Napa.....	Sharp, W. H. M.
	3 15.....	7.....	IV-V	Berkeley.....	Walking with Dr. King, not felt by either of us, 8. A.
	3 17.....	.....	.....	Yountville....	Undulatory twist, quite severe.
3 17 10....	.....	.....	San Francisco....	Double waves recorded on seismograph, W. It. E. and A. G. McA.	
3 17 15....	.....	.....	Oakland.....	Noticed by G. K. (J. on clock marked U. S. Observatory.	

THE CALIFORNIA EARTHQUAKE OF APRIL 18, 1906

---

REPORT

OF THE

STATE EARTHQUAKE INVESTIGATION COMMISSION

STATE EARTHQUAKE INVESTIGATION COMMISSION

ANDREW C. LAWSON

G. K. GILBERT

H. IT. REID

J. G. BRANNER

A. O. LEUSCHNER

GEORGE DAVIDSON

CHARLES BURKHALTER

W. W. CAMPBELL

# THE CALIFORNIA EARTHQUAKE OF APRIL 18, 1906

---

## REPORT OF THE STATE EARTHQUAKE INVESTIGATION COMMISSION IN TWO VOLUMES AND ATLAS

---

VOLUME I

---

BY

ANDREW C. LAWSON, CHAIRMAN

IN COLLABORATION WITH G. K. GILBERT, H. F. REID, J. C. BRANNER, H. W. FAIRBANKS, H. O. WOOD, J. F. HAYFORD AND A. L. BALDWIN, F. OMORI, A. O. LEUSCHNER, GEORGET DAVIDSON, F. E. MATTHES, R. ANDERSON, G. D. LOUDERBACK, R. S. HOLWAY, A. S. EAKLE, R. CRANDALL, G. F. HOFFMAN, G. A. WARRING, E. HUGHES, F. J. ROGERS, A. BAIRD, AND MANY OTHERS

---

VOLUME I, PART I

---



WASHINGTON, D. C.

PUBLISHED BY THE CARNEGIE INSTITUTION OF WASHINGTON

1008

Reprinted 1989

CARNEGIE INSTITUTION OF WASHINGTON

PUBLICATION NO. 87, VOLUME 1, PART I

Printed by  
T. S. Gushing Co. — Berwick & Smith Co.  
Norwood, Mass., U. S. A.

Reproduced offset by  
Sauls Lithograph Company, Inc.  
Washington, D. C.



## FOREWORD.

The reprinting of a sixty-year-old scientific publication, for scientific reasons and in response to a scientific demand, is a rare event indeed. Yet it is precisely for such reasons and in response to such a demand that the Carnegie Institution is presenting once again its Publication 87, *The California Earthquake of April 18, 1906*.

Dr. William W. Rubey, whose lifetime of investigation has influenced the course of modern geophysics so widely and deeply, and whose knowledge of the circumstances surrounding the 1906 earthquake is so unique, has honored this edition with an Introduction that provides in detail the setting in which the 1906 Report was made. It was Dr. Rubey who first sensed and emphasized the special timeliness of the Report today. We believe that geophysicists at large in coming years will share our gratitude to him.

The reprinting has been made possible by a grant of \$15,000 from the Harry Oscar Wood Fund for this purpose. The late Dr. Wood, a noted seismologist and fifteen years a Research Associate of the Institution, was also, most appropriately, a Principal Contributor to this volume.

CARYL P. HASKINS  
President, Carnegie Institution



## INTRODUCTION.

Recommendations to republish this book have come from numerous sources—most influentially, from Dr. Ian Campbell. As State Geologist of the California Division of Mines and Geology, Dr. Campbell was very much aware of the current widespread interest, both popular and academic, in earthquakes and of the demand for this report at libraries throughout California and elsewhere.

In order to understand the place and impact of this report when it appeared and to view it in its historical perspective, it is of interest to review briefly the progress of the science of seismology internationally and in the United States up until the publication of this report in 1908 and 1910.

Earthquakes have always been a source of keen interest—and of terror—to man. In ancient and medieval times, they were variously attributed to volcanic action, to the collapse of rock caverns, to explosions or the rushing of winds underground, and to supernatural causes. With such a range of suggested explanations, it is not surprising that individual earthquakes that caused great devastation and loss of life should have become the object of detailed examination by persons of a curious and sceptical turn of mind and with a bent toward natural philosophy. It is in large part the result of a series of monographic studies by such investigators that seismology emerged as a scientific discipline independent of the unrestrained speculation of earlier writers.

The scientific investigation of earthquakes may be said to have begun with a study, published in 1761 by John Michell of Cambridge University, of the great Lisbon earthquake of 1755. Michell broke free from the interpretations of classical writers of the past and relied solely on the evidence of direct observations. A later milestone in the development of seismology was an investigation of a devastating earthquake at Naples in 1857. In 1862 Robert Mallet, a practical engineer of Dublin and later of London, published a classic monograph on this Neapolitan quake that stood without rival until R. D. Oldham's report in 1899 on the great earthquake of 1897 at Assam, India.

In the years following Mallet's work, seismology advanced significantly as a scientific discipline. Michele de Rossi, Guiseppe Mercalli, and associates in Italy; Francois Forel and Albert Heim in Switzerland; Eduard Seuss in Austria; Montessus de Ballore in San Salvador, France, and Chile; and others in Germany and Russia described individual earthquakes, compiled regional catalogs of their occurrences, and systemized the reporting of earthquake intensities. On May 2, 1877, an earthquake was felt widely throughout central Europe, and in the following year the Swiss Seismological Commission was founded. It survives today as the Swiss Earthquake Service and has served as the model for similar organizations in other countries.

Seismology emerged as a quantitative science in the late 1880's in Japan. On February 22, 1880, Yokohama was rocked by a destructive earthquake, which became the subject of a memoir published by John Milne, a British professor of geology and mining at the Imperial College of Engineering at Tokyo. The memoir was published in 1880 and later that year, on Milne's initiative, a group of British and Japanese teachers formed the Seismological Society of Japan. Designers and builders of the first effective seismographs, Milne and his co-workers investigated individual quakes, the nature of earthquake motion, and the distribution of quakes in space and time. Individuals in the group

performed seismic experiments by means of artificial explosions, compiled comprehensive catalogs of Japanese and distant earthquakes, and drew the first travel time-distance curves. These innovative methods of investigation were the foundations of modern seismology.

The study of earthquakes advanced somewhat more slowly in North America than in Europe and Japan. J. D. Whitney, professor of geology at Harvard University, studied the Owens Valley, California, earthquake of 1872 and reported on it that same year. G. K. Gilbert, of the U. S. Geological Survey, in 1884 described numerous recent fault scarps bordering the Wasatch Mountains and elsewhere in the Great Basin and compared them to similar scarps produced by the Owens Valley quake. In 1889 C. E. Dutton, also of the U. S. Geological Survey, published a monograph on the great Charleston, South Carolina, earthquake of 1886. In a series of articles published from 1872 through 1886, C. G. Bockwood, professor of mathematics at Rutgers and then Princeton University, began the compilation of a catalog of earthquakes in the United States. Bockwood's catalog was continued for the earthquakes of California, Baja California, Oregon, and the Washington Territory from 1887 through 1898 by E. S. Holden, director of the Lick Observatory at Mount Hamilton, California, and two of his colleagues. These annual lists were published as Bulletins of the U. S. Geological Survey.

Holden installed the first seismographs in the United States at Lick Observatory and at the University of California at Berkeley in 1887. Probably the first seismic station in North America to use a seismograph with continuous recording was at Toronto in 1896. By 1901, there were continuous recording stations at Baltimore, Maryland; Philadelphia, Pennsylvania; Victoria, B.C.; and Mexico City, Mexico; and by 1904, there were stations in Washington, D. C.; Cheltenham, Maryland; Sitka, Alaska; and Honolulu, Hawaii.

In 1901 the first conference to establish an international organization of seismologists met at Strasbourg. By the time of the second conference in 1903, twenty countries were represented—double the number that had attended the first. H. F. Reid, the author of Volume II of the present study, represented the United States and was also present at the first meeting of the permanent commission in 1906, which meeting led to the founding of the International Seismological Association. That organization met first at the Hague in 1907 and once again Reid was one of the delegates.\*

On April 18, 1906, shortly after 5:00 a.m., a great earthquake struck San Francisco and a long narrow band of towns, villages, and countryside to the north-northwest and south-southeast. Many buildings were wrecked; hundreds of people were killed; electric power lines and gas mains were broken. Fires broke out and burned wildly for days, utterly out of control because of severed water mains.

The ground had broken open for more than 270 miles along a great fault—the San Andreas rift. The country on the east side of the rift had moved southward relative to the country on the west side of the rift. The greatest displacement had been 21 feet about 30 miles northwest of San Francisco.

Nearly all the scientists in California began immediately to assemble observations on the results of the quake. Professor A. C. Lawson, chairman of the geology department at the University of California, took the first steps that led to Governor George C. Pardee's appointment, three days after the shock, of a State Earthquake Investigation Commission to unify the work of scientific investigations then under way. The members of this

---

\* Gutenberg, Beno, Seismology, in *Geology, 1888-1906*, 50th Anniv. Vol. Geol. Soc. Amer., p. 460, 1941. Much additional information about the history of seismology may be found in:  
 Gfikk<sup>1</sup>, Sir Archibald, *The Founders of Geology*, 2nd ed., Macmillan & Co., 1905. Reprinted, Dover Pubs., Inc., 4th ed., 1962.  
 Adams, F. P., *The Birth and Development of the Geological Sciences*, Dover Pubs., Inc., 1938. Reprinted, 1966, 1954.  
 Davison, Charley, *The Founders of Seismology*. Cambridge Univ. Press, 240 pp., 1927.

Commission were Professor Lawson, Chairman; J. C. Branner, professor of geology at Stanford University; Charles Burckhalter, director of the Chabot Observatory at Oakland; W. W. Campbell, director of Lick Observatory; George Davidson, professor of astronomy at the University of California; G. K. Gilbert, geologist of the U. S. Geological Survey; A. O. Leuschner, professor of astronomy at the University of California; and H. F. Reid, professor of geology at Johns Hopkins University. With the exceptions of Gilbert and Reid, none of the Commission members were then known as students of earthquakes. Nevertheless, they were a distinguished and highly competent group of men. Two of the geologists and two of the astronomers were then members of the National Academy of Sciences and three others subsequently became members of that body.

At its first meeting three days after it was appointed, the Commission organized itself into two committees. One, chaired by Lawson, was to determine surface changes associated with the earthquake and to collect data on the intensity at different places. The second committee, with Leuschner as chairman, was assigned the collection of data on the time of arrival of the earthquake at different places. A few weeks later, when the main features of the quake had become known, a third committee, led by Reid, was appointed to consider problems of the geophysics of the earthquake. The three committees consisted of members of the Commission and 21 other scientists, many of whom—such as Fusakichi Omori, professor of seismology at the Imperial University of Tokyo and one of the greatest seismologists of Japan—were already well-known and many others who later became internationally known as leaders in geology, mathematics, meteorology, and other fields of science.

No State funds were available to defray the expenses of the Commission's investigation, but provision for this purpose was made by the Carnegie Institution of Washington.

The Commission submitted a preliminary report of twenty pages to Governor Pardee on May 31, 1906. In November of the same year, the constitution of the Seismological Society of America was adopted. The first president of the Society was George Davidson, followed in successive years by A. C. Lawson, J. C. Branner, and A. G. McAdie, a member of Committee II of the Earthquake Commission. The secretary of the Society for many years was S. D. Townley, also a member of Committee II.

In preparation of the final report, hundreds of people were interviewed and evidence was collected from every damaged area as well as from records from seismograph stations throughout the world. Lawson spent the winter of 1906-1907 in Washington compiling and editing individual reports from more than twenty collaborating scientists. He prepared an introduction, a section on the geology of the Coast Ranges, and many explanatory statements and summaries to weld the work into one unified report. Volume I, parts I and II, and the accompanying folio atlas were published in 1908 by the Carnegie Institution of Washington. Volume II, *The Mechanics of the Earthquake*, by H. F. Reid, followed in 1910.

The exhaustive report was favorably received on its publication and it continues even today to be very highly regarded by seismologists, geologists, and engineers concerned with earthquake damage to buildings. Volume I, established a model of earthquake investigation and reporting that has been widely followed ever since. Furthermore, it affords an invaluable pictorial record against which tectonic and other geologic changes since 1906 can be compared. Reid's masterly presentation of the elastic rebound theory of earthquakes in Volume II, remains today an apparently satisfactory explanation of one of the more important mechanisms of seismic activity. In all, the report stands as a milestone in the development of an understanding of earthquake mode of action and origin.

WILLIAM W. RYBBA



## PEEFAOE.

---

The account of the California earthquake of April 18, 1906, contained in this report, exemplifies the spirit of coöperation which pervades the scientific work in our day. Immediately following the great shock not only was the necessity of a scientific inquiry generally perceived, but it was realized that the occasion afforded an exceptional opportunity for adding to our knowledge of earthquakes. The scientific men of the state, each on his own initiative, began the work of assembling observations; the more intelligent citizens became persistent in their inquiries as to the nature of the earthquake, its extent and intensity, and the causes in general of such terrible disasters; and the state, thru its then Governor, George C. Pardee, unified the work of scientific investigation by the appointment of a committee of eight to direct the work. This committee was appointed on April 21, 1906, and became known as the State Earthquake Investigation Commission. On May 31, 1906, the Commission submitted a "Preliminary Report" to the Governor, which was printed and very generally distributed. In this report the details of the organization of the Commission, the program of its work, and the results attained to that date are set forth. But while the Commission acted under the authority of the Governor of the State, no money was provided by the Government for the conduct of its work. The embarrassment arising from this lack of funds was relieved about June 1, 1906, by a subvention from the Carnegie Institution of Washington^ which enabled the Commission to prosecute its work as it had been planned.

About the end of the year 1906, the greater part of the observational data having been collected, the work of sifting, coördinating, compiling, and editing the same devolved upon the Chairman of the Commission. The results of this work, including several special papers by various investigators, are contained in Volume I, parts I and II, of the report and in the twenty-five maps of the accompanying atlas. In this volume especial effort has been made to give due credit to every contributor, whether he be a scientific writer discussing some particular phase of the general problem, or a citizen assisting with local information. In all cases where there is no ascription of authorship the Chairman of the Commission is responsible for the statements made. The multiplicity of contributors has made it inconvenient to duplicate their names in the already lengthy table of contents.

In general, Volume I is a record of observations with quite subordinate discussion of the facts recorded. The effort to condense the record as far as possible has been tempered by the desire to omit no significant fact, so that the record may be as complete as possible for purposes of comparison with similar events which may occur in years to come. In the preparation of this volume the Chairman of the Commission gratefully acknowledges the kind advice and cordial assistance of Messrs. G. K. Gilbert and H. F. Reid. The Commission is also under great obligation to its Secretary, Mr. A. O. Leuschner, for his very efficient services.

Volume II is chiefly a discussion of instrumental records and of the data bearing upon the mechanics of earthquakes, by Mr. H. F. Reid, who also contributes a general

discussion of the theory of the seismograph, which is the first to appear in English. Accompanying this volume are many seismograms of the earthquake, which appear in the general atlas. These seismograms are records of the shock as registered at almost all the seismological stations the world over, and are published at the suggestion of the International Seismological Association for purposes of comparison with one another, to the end that the best recording devices may be generally adopted, and also for comparison with the similar series of seismograms of the Valparaiso earthquake of August 16, 1906, which has been published by the Association.

ANDREW C. LAWSON,

*Chairman State Earthquake Investigation Commission.*

BERKELEY, May 31, 1908.



# CONTENTS.

## PART I.

	PAGE
INTRODUCTION . . . . .	1
GEOLOGY OF THE COAST SYSTEM OF MOUNTAINS . . . . .	5
Definitions . . . . .	5
Geological History . . . . .	6
Structure . . . . .	12
Marginal Features, Granitic Rocks, Folds, Faults . . . . .	12-17
Geomorphic Features . . . . .	19
THE SAN ANDREAS RIFT AS A GEOMORPHIC FEATURE . . . . .	25
General . . . . .	25
Humboldt County. . . . .	26
Point Arena to Fort Ross . . . . .	26
Bodega Head to Bolinas Bay . . . . .	28
General Note, Characteristics of the Rift . . . . .	28-30
Mussel Rock to Pajaro River . . . . .	35
Pajaro River to the North End of the Colorado Desert . . . . .	38
San Jacinto Fault . . . . .	47
Review of Salient Features . . . . .	48
THE EARTH MOVEMENT ON THE FAULT OF APRIL 18, 1906 . . . . .	53
The Fault-trace . . . . .	53
Humboldt County . . . . .	54
Point Arena to Fort Ross . . . . .	59
Fort Ross . . . . .	63
Bodega Head to Tomales Bay . . . . .	65
Tomales Bay to Bolinas Lagoon . . . . .	66
The Fault-trace, Measurements of Throw, Movement Normal to the Fault-plane, Earlier Fault-traces, Cracks, Springs, Interpretation of Bedrock Cracks and Springs, Landslides, Ridging and Shifting of the Tide Lands . . . . .	66-77
The Question of Local Elevation and Depression of Land . . . . .	80
Introductory, About Bolinas Lagoon, About Tomales Bay, Bodega Bay, Summary, Postscript, Second Postscript . . . . .	80-85
Report on a Biological Reconnaissance of Bodega Bay, by William E. Ritter . . . . .	88
Report on a Biological Reconnaissance of Tomales Bay, by Charles A. Kofoid . . . . .	89
Report on a Biological Reconnaissance of the Bolinas Lagoon Region, by Charles A. Kofoid Bolinas Lagoon, The Seacoast Line, The Clam Patch . . . . .	90
Report on a Reconnaissance of Tomales Bay, by R. S. Holway . . . . .	91
Report on an Examination of Plants on Pepper Island, Bolinas Lagoon, by W. L. Jepson . . . . .	91
Mussel Rock to Crystal Springs Lake . . . . .	92
Course of the Fault-trace, Characteristics of the Fault-trace, Offsets on Fences, Pipes, Dams, etc., Exposures of the Fault-plane, Vertical Movement . . . . .	92-103
Crystal Springs Lake to Congress Springs . . . . .	104
Summary Statement, Crystal Springs Lake to Portola, Road from Judge Allen's Southward, Alpine Road, Black Mountain, Page Mill Road, Stevens Creek, South of Congress Springs . . . . .	104-109

	PAGE
Congress Springs to San Juan . . . . .	109
Cracks and Displacements along the Fault-trace, The Tunnel at Wright Station, Engineers' Measurements of Displacement . . . . .	109-111
Geodetic Measurements of Earth-movements . . . . .	114
General Statement . . . . .	114
Extent of New Triangulation . . . . .	114
The Old Triangulation . . . . .	116
Permanent Displacements produced by the Earthquakes of 1868 and 1906 . . . . .	117
Group 1. Northern Part of Primary Triangulation . . . . .	123
Group 2. Southern End of San Francisco Bay . . . . .	126
Group 3. Vicinity of Colma . . . . .	126
Group 4. Tomales Bay . . . . .	127
Group 5. Vicinity of Fort Ross . . . . .	128
Group 6. Point Arena . . . . .	129
Group 7. Southern Part of Primary Triangulation . . . . .	130
Distribution of Earth Movement. Summary . . . . .	132
Discussion of Assumptions . . . . .	135
Changes in Elevation . . . . .	140
Notes on the Comparison of the Faults of the three Earthquakes of Mino-Owari, Formosa, and California, by F. Omori . . . . .	146
Review of Salient Features . . . . .	147
 PROVISION FOR MEASUREMENT OF FUTURE MOVEMENTS ON THE SAN ANDREAS FAULT . . . . .	 152
Relative Positions of the Monuments . . . . .	153
Olema . . . . .	153
Description of Monuments, Leveling Record, Base-line Measures, Level Correction . . . . .	153-155
Crystal Springs Lake . . . . .	156
Description of Stations, Base-line Measures, Relative Elevations, Method of observing Angles, Abstracts of Horizontal Angles . . . . .	156-158
 ISOSEISMALS: DISTRIBUTION OF APPARENT INTENSITY . . . . .	 160
Introductory . . . . .	160
Southern Oregon . . . . .	163
Klamath Mountains and Northeastern California . . . . .	163
Crescent City, Klamath, Peanut, Montague, Gazelle, Sisson, Dunsmuir, Etna Mills, Denny, Big Bar, Papoose, Altruras, Susanville, McArthur, Stella, Redding, Cotton- wood . . . . .	163-165
Humboldt County. . . . .	165
Arcata, Eureka, South of Eureka, Freshwater, Ferndale, Cape Mendocino Light Station, Petrolia, Fortuna, Pepperwood, Briceland, Thorn . . . . .	165-170
Northern Mendocino County. . . . .	170
Shelter Cove to Alder Creek . . . . .	172
Monroe, Hardy, Westport, High-nook, Cleone, Bransconib, Fort Bragg, Caspar, Men- docino, Navarro, Greenwood, Albion and Little River, Bridgeport . . . . .	172-176
Alder Creek to Fort Ross . . . . .	176
Manchester, Point Arena, Gualala, Annals, Stewart's Point, Gualala Valley, Planta- tion House, Timber Cove, Fort Ross . . . . .	176-182
Between the Coast and the Russian River . . . . .	182
Healdsburg to Willets . . . . .	183
Healdsburg, Alexander Valley to Mt. St. Helena, Cracks in the Russian River Flood Plain, Maesaum Slide, Geyserville, Cloverdale, Ukiah, Willets . . . . .	183-188
Clear Lake District . . . . .	188
Hoplund to Lakeport, Upper Lake, Laurel Dell, Lakeport to Lower Lake, Cache Creek Canyon, Vicinity of Upper Lake, Bartlett Springs, Lower Lake, San- hedrin . . . . .	188-190
Fort Ross to Bodega Head . . . . .	190
Duncan's Mills . . . . .	191

CONTENTS.

XV

	PAGE
Tomales Bay to Bolinas Bay . . . . .	191
Along the Fault, Bolinas, Olema, Point Reyes Station, Inverness, Inverness to Point Reyes Light-house, Sunshine Ranch and Vicinity, Bear Valley, Seven Lakes, West of Bolinas, North of Point Reyes Station, Sausalito to Point Reyes Station, Ross to Bolinas, Mill Valley to Bolinas, Distribution, Notes by Other Observers . . . . .	191-198
Between the Coast and Santa Rosa Valley . . . . .	198
Tomales, Dillon's Beach, Tomales to Pefcaluma, Valley Ford, Bloonifield, Bodega . . . . .	198-199
Santa Rosa . . . . .	199
Vicinity of Santa Rosa . . . . .	203
Cotate, Wells East of Santa Rosa, Sebastopol, Altruria, Mark West Springs, Windsor, Guerneville . . . . .	203-206
Santa Rosa Valley to San Francisco Bay. . . . .	206
Petaluina, Lakeville, Petaluma northwai'd up Sonoma Mountain, Petaluma to Sebas- topol, San Rafael, Novato, Sausalito, Mt. Tamalpais, Angel Island Light Station, Yerba Buena Island, Alcatraz Island, Southeast Farallon Island . . . . .	206-209
Sonoma Valley. . . . .	209
Melita, Kenwood, Glen Ellen, Eldridge State Home, Aqua Caliente, Boyes Hot Springs, El Verano, Sonoma, Shellville. . . . .	209-210
Napa Valley to Sacramento Valley . . . . .	210
Napa Valley, Calistoga, St. Helena, Rutherford, Veterans' Home, Napa State Hospital, Napa, Wooden Valley, Pope Valley, Berryessa Valley, Vallejo, Mare Island, Vallejo Junction, St. John's Quicksilver Aline, Benicia . . . . .	210-214
Sacramento Valley . . . . .	214
Red Bluff, Corning, Chico, Willows, Williams, Elk Creek, Colusa, Meridian, Marys- ville, Yuba City, Black's Station, Knight's Landing, Lincoln, Fair Oaks, Sacramento, Gait, Lone, Suisun, Elmira, Vacaville, Esparto, Capay, Guinda, Rumsey, Woodland, Davisville, Maine Prairie, Rio Vista, Collinsville . . . . .	214-217
Northern Sierra Nevada . . . . .	217
Butte County, Plunias County, Sierra County, Nevada County, Placer County, George- town, Nashville, Pino Grande, Drytown, Milton, Railroad Flat, West Point, Gold King Mine, Blanchard, Columbia, Sonora, Tuolumne, Jupiter, Sequoia, Yosemite Valley . . . . .	217-219
Distribution of Appareut Intensity in San Francisco . . . . .	220
Introduction . . . . .	220
Physiography. . . . .	220
Geology. . . . .	221
Destructive Effects and Intensity Scales . . . . .	222
Detailed Description of the Evidence by Localities . . . . .	227
Localities of Lesser Importance affected by Intensity of Grade B. . . . .	231
Phenomena of Especial Interest . . . . .	233
Conclusions . . . . .	241
Addenda . . . . .	241
Subsidence of Made Land, Possible Premonitory Movements, Effect of the Shock near the Beach, Effect of the Shock on the Gas Plant and Pipes, Effect on Certain Street Railways, Deformation of the U. S. Government Buildings, New Post-office, Appraiser's Building, Mint . . . . .	241-245
The San Francisco Peninsula . . . . .	24f
The San Mateo District . . . . .	246
San Carlos, Belmont, San Mateo, Burlingarne, Millbrae, San Bruno . . . . .	2HJ-247
TIH Merced Valley District . . . . .	247
Baden, South San Francisco, The Cemeteries, Landslides, The Coast North of Mussel Rock, Lake Merced . . . . .	217-251
The Area Southwest of the San Andreas Fault . . . . .	251
Difference of Apparent Intensity on the Two Sides of the Fault, Laguna Salada Valley, Cak'nt Valley, San Pedro Point, Moutara Point, Landslides, Pilarcitos Can- yon, Cahill's Ridge, Sawyer's Ridge . . . . .	251-253
Conclusions . . . . .	253
Notes by Other Observers . . . . .	254
San Mateo, Redwood . . . . .	254

## PART II.

	PAGE
Area of the Santa Cruz Quadrangle of the U. S. G. S.	255
Stanford University, Palo Alto, Menlo Park, Fair Oaks, Redwood, East of Palo Alto, Mayfield to Guth Landing, Mountain View, Saratoga to Congress Springs, Stanford University to Portola and Woodside, Page Mill and Alpine Roads, King's Mountain down Purisima Creek, Bear Creek, Half Moon Bay, Purisima and San Gregorio, La Honda, Congress Springs to Boulder Creek, Ben Lomond Mountain to the Coast, Santa Cruz, Road into Scott Valley, Felton, Pescadero to Butano Creek, Pomponio Creek, The Coast from Pigeon Point to Ano Nuevo Bay	255-274
Los Gatos to San Juan.	274
Los Gatos, Lexington, Summit Hotel, Wright Station, Burrell School, Morrell Ranch, About Four Miles South of Wright Station, Skyland, Soquel, Chittenden, San Juan.	274-279
Santa Clara Valley.	279
Newark, Centerville, Mission San Jose, Irvington, Milpitas, Agnews, Alviso to Milpitas, Warm Springs, Milpitas-San Jose Road, Alum Rock Road, Calaveras Valley to Evergreen and Vicinity, Santa Clara, Cemeteries, San Jose, County Road South of San Jose, Los Gatos to Gilroy.	279-288
Hollister to Priest Valley.	288
Hollister, From Hollister to San Benito, Priest Valley.	288-291
Monterey Bay and Eastward.	291
Pacific Grove, Monterey and Del Monte, Castroville to Soquel	291-293
Salinas to San Luis Obispo and Westward.	293
Effect of the Shock on Alluvium, Effect upon Structures, Objects, etc., Prunedale, Salinas, Spreckels and Vicinity, Southward from Salinas, South and West of Salinas Valley.	293-299
San Luis Obispo to San Bernardino	299
Arroyo Grande, Santa Maria, Casmalia, Surf, Lompoc, Point Conception Light-house Station, Santa Barbara, Carpenteria, Saticoy, Hueneme Light-house Station, Calabassas, Santa Monica, Los Angeles, Anaheim, San Bernardino	299-300
Bay of San Francisco to the San Joaquin Valley	300
Berkeley, Oakland, Oakland Cemeteries, Alameda, Southeast of Oakland, Mt. Eden, Decoto, Alvarado, Lick Observatory, Niles, Sunol, Verona, Pleasanton, Livermore, Santa Rita, Dublin, San Ramon, Danville, Walnut Creek, Clayton, Concord, Martinez, Cornwall and Black Diamond, Antioch, Bethany, Byron Hot Springs, Tracy, Lathrop, Stockton, Farmington, Central San Joaquin County, Modesto, Ceres, Oakdale, Westley.	300-316
The Coast Ranges East of the Kift and South of Mt. Hamilton and West Side of the San Joaquin Valley from Westley to Dudley	316
Pacheco Pass Road, Mountain House, San Luis Ranch, Los Baños, Volta, Newman, Crow's Landing, Grayson and Westley, From Westley to Mt. Hamilton, Faicenes, Elkhorn, Emmet Post-office, Panoche Valley, Mendota, Meudota to Coalinga, Coaliuga, Dudley, Cholame, Parkfield, Stone Canyon Coal Mine, Peachtree, Cantua Creek.	316-319
East Side of the San Joaquin Valley South of Modesto and the Adjacent Portions of the Sierra Nevada	319
Merced, Madera, Fresno, Reedley, Visalia, Dinuba, Bakersfield, Isabella	319-320
East of the Sierra Nevada, by George D. Louderback	321
General Note, Round Hole, Peavine Mountain, Reno, Olinghous, Wadsworth, Hazen, Virginia City, Wabuska, Yerington, Fallon, Fairview, Lovelock, Mill City, Unionville, Winnemueca, Hawthorne, Mina, Bodie, Mono Lake, Candelaria, Laws, Tonopah, Goldfield, Eureka, Bishop, Independence, Lone Pine, Keeler	321-324
The Earthquake of April 19, 1906, about 2" 5" p. M.	324
The Earthquake of April 19, 1908, 5 <sup>th</sup> 30" p. M.	324
Observations by J. A. Reid.	325
Experiments with a Shaking Machine.	326

CONTENTS.

xvii

	PAGE
Review of the Distribution of Apparent Intensity . . . . .	335
General Disposition of the Isoseismals . . . . .	335
Relation of Apparent Intensity to Valleys . . . . .	336
Relation of Apparent Intensity to Known Faults . . . . .	346
DIRECTIONS OF VIBRATORY MOVEMENT. . . . .	351
General Note . . . . .	351
Effects of the Earthquake on Houses in San Mateo and Burlingame . . . . .	354
Criteria . . . . .	354
Damages . . . . .	355
The Effects upon Brick and Stone Buildings, Wooden Buildings, Foundations, Brick Chimneys, Chimneys Other than Brick, Plaster, Dishes, etc., Windows, A Resistant Type of Structure . . . . .	355-358
The Manner and Direction of Movement . . . . .	358
Kinds of Movement, Movement of Houses, Movement of Chimneys, Movement of Dishes, Books, etc., Movement of Furniture, etc., Experience and Testimony of People, Splashing of Liquids, Movement of Various Other Bodies, Predominance of Northwest and Southwest Movements, Cause of Shifting, Relative Intensity of the Main Movement . . . . .	358-364
Intensities . . . . .	365
Conclusions . . . . .	366
Directions in the Tumbales-Bolinas District . . . . .	367
Directions Indicated by Monuments in Cemeteries . . . . .	367
MARINE PHENOMENA . . . . .	369
The Effect of the Earth Movement on the Sea-level, The Shock felt by Ships, Shocks felt at Sea subsequent to April 18, 1906 . . . . .	369-372
NUMBER OF MAXIMA IN THE MAIN SHOCK . . . . .	374
SOUNDS CONNECTED WITH THE EARTHQUAKE . . . . .	377
VISIBLE UNDULATIONS OF THE GROUND . . . . .	380
PATHOGENIC EFFECTS OF THE EARTHQUAKE . . . . .	382
EFFECT OF THE EARTHQUAKE ON ANIMALS . . . . .	382
Horses, Cattle, Cats, Dogs, Chickens, Wild Animals . . . . .	382-383
MINOR GEOLOGICAL EFFECTS OF THE EARTHQUAKE . . . . .	384
Landslides . . . . .	384
Earth-avalanches . . . . .	387
Earth-slumps . . . . .	390
Cape Fortunas Earth-slump, San Pablo Earth-slump . . . . .	390-391
Earth-flows . . . . .	392
Mount Olivet Cemetery, Vicinity of Half Moon Bay, Relation of Earth-flows to Rainfall . . . . .	392-398
Earth-lurches . . . . .	400
Cracks and Fissures . . . . .	401
Effect of the Earthquake upon Underground Waters . . . . .	402
Significance of the Phenomena . . . . .	402
Record of Springs and Wells Affected . . . . .	404
RECORD OF AFTER-SHOCKS . . . . .	410
COMPARISON WITH OTHER SKVERE EARTHQUAKES IN THE SAME REGION . . . . .	434
The Earthquake of 1808 . . . . .	434
The Fault-trace . . . . .	434
The Effect of the Earthquake in San Francisco . . . . .	430
The Distribution of Intensity thruout the State . . . . .	439
Summary . . . . .	447
The Earthquake of 1817 . . . . .	448
The Earthquake of 1807 . . . . .	449

## LIST OF ILLUSTRATIONS.

PLATE	TO FACE PAGE
1. A, Wood Gulch, Hiunboldt County. . . . .	26
2. A, Rift above Shelter Cove, Hurnboldt County. B, Rift on divide between the upper Gualala and coast north of Fort Ross . . . . .	26
3. A, Rift above Shelter Cove. B, Northeast of Shelter Cove. Rift in middle ground. C and I), Looking up Garcia River along Rift . . . . .	26
4. Characteristic Rift features southeast of Fort Ross . . . . .	26
5. Characteristic Rift features near Fort Ross . . . . .	28
6. A, Looking down Tomales Bay from near Olema. B, Looking down Bolinas Lagoon Bay toward the Golden Gate . . . . .	32
7. A, Looking north in Bolinas-Tomales Valley. B, Fault-sag and side-hill ridge near Bondi-etti's ranch . . . . .	32
8. A, Fault-sag 6 miles south of Olema. B, Side-hill ridge 4 miles south of Olema . . . . .	34
9. A, Side-hill ridge south of Olema. B, Rift topography, with pond, south of Olema . . . . .	34
10. A, Rift topography, with pond, near Bondi-etti's ranch. B, Fault-trace near same . . . . .	34
11. A, Fault-sag 2 miles south of Olema. B, Fault-sag 3 miles south of Olema . . . . .	34
12. A, Looking northwest along Rift. B, Great landslide at Mussel Rock, where Rift enters Coast from the Pacific . . . . .	36
13. Characteristic ponds along Rift southeast of Mussel Rock. . . . .	36
14. Features of Rift between Mussel Rock and San Andreas Lake. . . . .	36
15. Geomorphologic and Geologic Map of San Francisco Peninsula . . . . .	38
16. A, Rift valley between San Andreas and Crystal Springs. B, Rift valley 5 miles west of Stanford University. . . . .	38
17. A, Rift followed by Pajaro River at Chittenden. Dislocated bridge supported by false work. B, Rift a mile southeast of Chittenden. . . . .	38
18. A, Rift 3 miles southeast of Chittenden. B, Ponds along Rift near San Benito . . . . .	40
19. A, Rift south of Dry Lake Valley, San Benito County. B, Ancient scarp on line of Rift west of Parkfield, Cholame Valley. . . . .	40
20. Branch of Rift 2 miles southeast of Parkfield, Cholame Valley. . . . .	40
21. Rift, Carissa Plain. . . . .	40
22. A, Cuddy Valley from head of San Kmedio Canyon. B, Old Fault-scarp in Rift . . . . .	42
23. A, Rift from Emerson's place, near Pattiway. B, Looking east along Rift from Gorman Station . . . . .	42
24. A, Pond and scarp in Rift east of Gorman Station. B, Lower Lake Elizabeth in Rift . . . . .	42
25. A, Rift between Lake Elizabeth and Palmdale. B, Rift scarp west of Palmdale . . . . .	42
28. A, Sink between 2 scarps of Rift south of Palmdale. B, Pond in Rift 2 miles west of Big Rock Creek, Mojave Desert . . . . .	44
27. A, Fault-scarp in Rift, Mojave Desert west of Big Rock Creek. B, Ridge in Rift near head of Swartout Valley. . . . .	44
2X. A, Rift across mountain crest west of Swartout Valley. North slope of San Gabriel Range. B, Lone Pine Canyon across lower end of Cajon Canyon . . . . .	44
29. A, Rift from Cajon Pass, showing double scarp. B, Double fault-scarp in Rift north of Highland, at base of San Bernardino Range. . . . .	44
30. A, Looking across Borego Valley toward south end of San Jacinto fault-scarp. H, Nearer view, upper end of Borego Valley. . . . .	47
31. A, Fault-scarp passing thru saddle, at head of Wood Gulch. B, Auxiliary fault-trace following old warp in saddle between Wood Gulch and Hiunboldt Creek. C Telegraph Hill along fault-trace. I), Looking north-northwest along main fault. . . . .	51
ii). A, Kooky .4re;mi eliff .7d feet, hi^h on north side of Alder Creek. B, Fault passing under bridge over Alder Creek. C, Barn of E. E. Fitch, north of Manchester. D, East-west fence d.2,"j mile north of Manchester offset by fault . . . . .	51

## LIST OF ILLUSTRATIONS.

XIX

PLATE	TO FACE PAGE
33. A, East-west fence near saddle between Garcia River and Brush Creek. B, Small railway trestle, Little North Fork, Gualala River. C and D, Buckled track, Little North Fork, Gualala River . . . . .	6 0
34. A, Fault-trace in redwood forest near Fort Ross. B, Dislocation in fence near Fort Ross . . . . .	64
35. A, Accentuation of old scarp by new fault 1.5 miles north of Fort Ross. B, Fault-trace on grass-covered slope near Fort Ross . . . . .	6 4
36. A, Offset of fence a mile east of Fort Ross. B, Fault-trace and dislocated fence near Fort Ross. C, Roadway offset 12 feet above Fort Ross. D, Accentuation of old fault-scarp by new fault, near Fort Ross . . . . .	6 4
37. A, Offset stream trench by fault and ponding water by fault-scarp. B, Fault-trace a mile northwest of Bolina Lagoon. . . . .	.64
38. A, Fault-trace in old depression, Doda's ranch a mile southeast of Fort Ross. B, Fault-trace marked by scarp 3± feet high on west side. C, Fault-trace across tidal flats of Tomales Bay near its mouth. 1), Fault-trace between garden and house, Skinner's ranch near Olema . . . . .	.66
39. A, Branch of fault-trace in north part of Bolinas. B, Branch of fault-trace near Bondiotti's ranch. . . . .	.66
40. A, The fault-trace a mile northwest of Olema. B, Fault-trace west of Olema . . . . .	60
41. A, On Pepper Island. B, Looking north from hill west of Woodville . . . . .	66
42. A, Sag followed by fault-trace north of Strain ranch. B, Looking southeast from point near Shafter's ranch, Olema. . . . .	.68
43. A, Fault-trace south of Olema. B, Looking southeast across hill-top a mile south of Olema . . . . .	68
44. Fault-trace northwest of Olema . . . . .	.68
45. A, Fault-trace on Papermill delta. B, Branch of fault-trace in "Second Valley," at Inverness . . . . .	68
46. A, Fault-trace on Papermill delta. B, Fault-trace at Skinner place, near Olema . . . . .	72
47. A, Branch of fault-trace on "north mesa," at Inverness. B, Road offset by fault . . . . .	72
48. A, Fault-trace a mile northwest of Olema. B, Fault-trace near Bondiotti's ranch . . . . .	7 2
49. A, Fence offset by fault. B, Cracks in tidal mud near head of Bolinas Lagoon . . . . .	7 2
50. A, Road embankment broken by shaking of soft ground beneath. B, Faults in road embankment southwest of Point Reyes Station . . . . .	76
51. A, Roadside crack between Inverness and Point Reyes P.O. B, Roadside crack southeast of Inverness. . . . .	.76
52. A, Group of earthquake cracks southwest of head Pine Gulch Creek. B, Earthquake cracks in Bolinas at edge of an earthquake sag. . . . .	76
53. A, Fault-scarp on earthquake crack. B, Landslide from road-cliff west of Inverness . . . . .	76
54. A, Landslide 4 miles northwest of Bolinas Lagoon. B, Ridged mud-plain a mile from Inverness. . . . .	78
55. A, Landslide 2.5 miles northwest of Bolinas Lagoon. B, South part of Inverness shoal, at low tide, April 28, 1906. . . . .	78
56. A, Ridges on tidal flat of Tomales Bay, 1 mile south of Inverness. B, Bedrock shoal near Bolinas, with clam patch near outer edge. C, Clam patch near Bolinas. D, Salicornia in Limantour Bay. . . . .	78
57. A, Martinelli's pier at Inverness. B, Bailey's pier at Inverness. . . . .	80
58. Bailey's pier at Inverness . . . . .	80
59. A, Rupture of 30-inch water-pipe by fault, northwest of San Andreas Lake. B, Thrust of 10-inch water-pipe by fault, northwest of San Andreas Lake. . . . .	100
60. A, Offset in 30-inch water-pipe by fault, northwest of San Andreas Lake. B, Collapse of same. C, Offset of 6.5 feet in fence, northwest of San Andreas Lake. D, Offset of 6.5 feet in fence between San Andreas and Crystal Springs Lake . . . . .	100
61. A, Fault-trace where it passes into San Andreas Lake. B, Offset fence near Crystal Springs Lake. . . . .	100
62. A, Exposure of slicken-sided fault-plane near Crystal Springs Lake. B, Offset of road by main fault near Searsville reservoir . . . . .	100
63. A, Offset of Alpine road 5 miles west of Stanford University. B, Offset of 8 feet in fence on Folger ranch, near Woodville . . . . .	108
64. A, Reservoir in saddle south of Saratoga traversed by main fault. B, Offset in fence at Morrell's ranch, above tunnel at Wrijht station. . . . .	110

## LIST OF ILLUSTRATIONS.

PLATE	TO FACE PAGE
65. A, Offset in road near Wright. B, Steel bridge over Pajaro River, near Chittenden	110
66. A, Wrecked stores, Ferndale, Humboldt County. B, Wrecked buildings, Fort Bragg	172
67. A, Odd Fellows' Hall, Fort Bragg. Looking east. B, U. O. Co. mill, Fort Bragg	172
68. A, Point Arena. Brick house destroyed; wooden houses little affected. B, Wreck of suspended flume across Garcia River. C, Collapsed wagon bridge over Gualala River	176
69. A, Sound redwood tree snapped off 42 feet from top. Near Fort Ross. B, Redwood tree snapped off, above Fort Ross. C, Uprooted tree about half mile west of Garcia River. D, Bridge over South Fork, Gualala River.	176
70. A, Bell and Kinslow building, Healdsburg. B, Odd Fellows' Hall, Healdsburg	183
71. A, Buckled water-pipe, Inverness. B, Wrecked water-tank, near Inverness	194
72. A, Ruin of Inverness Reservoir. B, Wrecked water-tank, near Inverness	194
73. A, Cold-storage plant, Petaluma. B, Buckner Hotel, Willets. C, Corner Main and Washington Streets, Petaluma	198
74. Santa Rosa	200
75. Santa Rosa	200
76. Santa Rosa	200
77. Santa Rosa	200
78. City Hall, Santa Rosa	202
79. A, House moved 7 feet by collapse of underpinning, Santa Rosa. B, House lurched to north, Santa Rosa. C, Wrecked dwelling, Santa Rosa. D, Wreck of brick structure, Santa Rosa	202
80. A and B, Cemeteries, Santa Rosa. C and D, Cemeteries, Sebastopol	202
81. A, East side of main street, Sebastopol. B, Wrecked buildings, Sebastopol. C, Stone house, 15 miles southeast of Tomales. D, Wrecked church, Tomales	202
82. City Hall, San Francisco	228
83. A, Near view of wreck at City Hall, San Francisco. B, Cattle killed by falling masonry, San Francisco	228
84. Observatory, Strawberry Hill, Golden Gate Park, San Francisco	230
85. Observatory, Strawberry Hill, Golden Gate Park, San Francisco	230
86. Restaurant at Children's Playground, Golden Gate Park, San Francisco	230
87. A, O'Farrell Street, San Francisco, after earthquake and before fire. B, Geary Street, between Filmore and Steiner Streets, San Francisco	230
88. A, Frame building on west side of Eleventh Avenue, just south of California Street, San Francisco. B, Slip of a fill on Union Street, just west of Steiner Street, San Francisco. C, Russ Street, between Folsom and Howard Streets, San Francisco. D, Moss Street, between Folsom and Howard Streets, San Francisco	236
89. A, Columbia Street just south of Folsom Street, San Francisco. Slumping, depression, and furrowing of block pavement. B, Bryant Street, near Fourth Street, San Francisco. Flexure of heavily ballasted car tracks in block pavement. C, Sixth Street, near Howard. Sidewalk held up by piling foundation of building. D, Looking along Dore Street, from Bryant toward Brannan	236
ML A, Dore Street from Brannan toward Bryant. B, Dore Street, near Brannan. C, Eighteenth Street, just east of Shotwell. D, Southwest corner Portola and Waller Streets	236
HI. Ninth Street, between Bryant and Brannan	237
92. A, St. Dominic's Church, Bush and Steiner Streets. B, Looking south on Howard Street from near Seventeenth Street. Compressional flexure of car rails	238
83. A, East side of Howard Street, between Seventeenth and Eighteenth Streets. B, Valentia Street, near Eighteenth	240
94. A, View along Nineteenth Street, from Guerrero Street. B, San Francisco Post-office, Mission and Seventh Streets	240
95. A, WTKlawn Cemetery, south of San Francisco. B, Hills of Eternity Cemetery, south of San Francisco	250
M. A, Holy Cross Cemetery Station, south of San Francisco. B, Holy Cross Cemetery, south of San Francisco	250
II7. A, Overthrown monument, Holy Cross Cemetery. B, Brick building and high chimney left standing. South San Francisco. C, Roadbed and rails of electric railway on marsh west of Saw Bruno. D, Roadbed and rails of electric railway between Baden and San Bruno	250



LIST OF ILLUSTRATIONS.

xxi

PLATE	TO FACE PAGE
98. A, Wreck of 1-story brick railway warehouse, San Mateo. B, Brick stable, San Mateo . . . . .	250
99. A, Wreck of 2-story brick building, San Mateo. B, Wreck of 2-story brick building, San Mateo . . . . .	256
100. A, Trestle carrying a 30-inch water pipe across Frawley Gulch demolished by shock. B, Statue of Agassis: thrown from its niche above arches, Stanford University . . . . .	256
101. A, Destruction of arcade at Sacred Heart Convent, Menlo Park. B, Gateway of Campus, Stanford University . . . . .	250
102. A, Geology Building, Stanford University. B, Panorama of destruction, Stanford University. Memorial chapel in middle right . . . . .	250
103. A, Ruin of Memorial Arch, Stanford University. B, Front view of Memorial Church, Stanford University. . . . .	258
104. A, Wreck of the Library Building, Stanford University. B, Wreck of the Gymnasium Building, Stanford University. . . . .	258
105. A, Wrecked arches, Geology Building, Stanford University. B, Arches that moved on their supporting columns, Stanford University. . . . .	258
106. A, Tree overthrown by earthquake, west of Searsville Lake. B, Live oak uprooted by earthquake, west of Seai'sville Lake . . . . .	258
107. A, Shortening of railroad track between Los Gatos and Santa Cruz. B, Morrell house, near Wright Station. . . . .	276
108. A, Agnew's Insane Asylum. North end of female wards. B, Agnew's Insane Asylum. North side. C, Phelan Building, San Jose. D, Hall of Records, San Jose . . . . .	282
109. A, High-school, San Jose. B, Hotel Vendome, Annex, San Jose. . . . .	282
110. A, Post-office, San Jose. B, Box factory, corner Fifth and Julian Streets, San Jose . . . . .	284
111. San Jose. . . . .	284
112. San Jose. . . . .	284
113. San Jose. . . . .	284
114. A and B, Gilroy. C, Hollister. Demolition of brick building shown in D. D, Hollister. Same building as shown in C, before earthquake. . . . .	289
115. A, Alvarado. Wreck of molasses tanks, Alameda Sugar Company. B, Salinas. Wreck of corner store . . . . .	294
116. A, Near Watsonville. Concrete pier of bridge shattered. B, Salinas. Wreck of store. C, Salinas. Walls of building thrown out. D, Moss Landing. Wreck of wooden warehouse. . . . .	296
117. A, Spreckels Sugar Mill, near Salinas. Entire building buckled. B, Spreckels Sugar Mill . . . . .	296
118. A, Berkeley. Institute for Deaf, Dumb, and Blind. South wing. B, North wing . . . . .	300
119. A, Berkeley. Barker Block. Shattuck Avenue and Dwight Way. B, Berkeley. High-school. . . . .	300
120. A, Oakland. Central Bank Building. B, Smokestack of power plant, Oakland Traction Company. . . . .	302
121. A, Oakland. Flax Works, Union and Third streets. B, Prescott School, Ninth and Campbell Streets. . . . .	302
122. A, Oakland. First Baptist Church, Telegraph Avenue. B, Fourteenth Street, between Washington and Broadway. . . . .	302
123. A, Bridge over Salinas River, 4 miles south of Salinas. B, Los Banos Hotel. C, Los Banos Bank. D, Coalinga . . . . .	316
124. A, Maacama earth-avalanche. B, Close view. C, Earth-avalanche in granite on road near Half Moon Bay. D, Deer Creek, Santa Cruz Mountains. Earth-avalanche from Grissly Peak. . . . .	388
125. A, Deer Creek, Santa Cruz Mountains. B, Scarp of landslide, near Cantua . . . . .	389
126. A, Earth-avalanche on side of canyon, near Chittenden. B, Earth-avalanche in sandstone, near Half Moon Bay. . . . .	390
127. Earth-slumps at Cape Fortunat, Humboldt, County. . . . .	390
128. Earth-slumps east of San Pablo. . . . .	392
129. A, Earth-slump north of Toniales, carrying railway roadbed with it. B, Earth-slump north-east of Tomales, at Freeman's. C, Earth-slump at Mussel Rock. D, Scarp of Mussel Rock earth-slump . . . . .	392
130. Earth-flow at Mount Olivet Cemetery. . . . .	392

PLATE	TO FACE PAGE
131. A, Earth-flow, Mount Olivet Cemetery, at base of San Bruno scarp. B, Earth-flow in hills east of Half Moon Bay. . . . .	392
13*2. A, Earth-flow in hills east of Half Moon Bay. B, Earth-flow in small valley near Half Moon Bay. . . . .	394
14. A, Earth-flow illustrating floor of cavity from which flow came. B, Earth-flow 4 miles east of Half Moon Bay. . . . .	394
14. A, Moss Landing. House, tree, and fence moved 12 feet by lurching of ground toward Salinas River. B, Moss Landing. Lurching of ground toward Salinas River carried piles from beneath bridge timbers, causing it to collapse . . . . .	400
15. A, Moss Landing. Lurching of ground toward Salinas River, to left, carried piles from beneath bridge timbers and caused bridge to collapse. B, Moss Landing. Deformation of surface due to lurching of ground toward Salinas River . . . . .	400
15. A, Lurching of the ground toward Salinas River and consequent collapse, near Spreckels. B, Detail of view shown in A. . . . .	400
17. A, Lurching of ground toward Salinas River, with consequent collapse. B, Destruction of road due to lurching of ground toward Salinas River near Spreckels . . . . .	400
138. Eel River, near Ferndale . . . . .	402
139. A, Russian River, west of Windsor. B, Russian River. Crack in flood plain parallel to river. C, Fissures in alluvium, Tevis ranch, near Alma. D, Upheaval of bottom of artificial lake, Tevis ranch, near Alma . . . . .	402
140. A, Secondary cracks in alluvium near Milpitas. B, Secondary cracks in alluvium on banks of Coyote Creek. . . . .	402
141. A, Concentric cracks in ground around an old alkaline spring, north of Livermore. B, Secondary crack in alluvial floodplain on Pajaro River . . . . .	402
142. A, Craterlets in sand near marsh east of Bodega Bay. B, Craterlets along fault-trace on sand spit at mouth of Tomales Bay . . . . .	404
143. A, Craterlets in fields near Milpitas. B, Craterlets near Watsonville . . . . .	404
144. A, Flour mill, Haywards. B, Edmouson's warehouse, Haywards. C, Flour mill and warehouse, Haywards. D, Pierce's house, Haywards. E, Haywards. Wreck of buildings by earthquake of 1851. F, Court-house, San Leandro . . . . .	434
145. Effects of the earthquake of 1851 in San Francisco . . . . .	434
146. Map of San Francisco, showing distribution and degree of damage caused by the earthquake of 1851 in relation to the made land. . . . .	436

## LIST OF MAPS AND SEISMOGRAMS IN ACCOMPANYING ATLAS.

## MAPS.

- No.
1. Geomorphic map of California and Nevada with parts of Oregon and Idaho, showing' diastrophic character of relief, the steep descent from the subcontinental shelf to floor of the Pacific, and the more important faults of California.
  2. Map of a part of the coast of California, etc.
  3. Detail map of a typical part of San Andreas Rift near Fort Ross, Sonoma County, California, showing geomorphic features and trace of fault.
  4. Map of region about San Francisco Bay, etc.
  5. Map of part of San Francisco, etc.
  6. Map of California, Mount Pinos Quadrangle.
  7. Map of California, Tejon Quadrangle.
  8. Map of California, Palmdale Quadrangle, of the U. S. Geological Survey, showing San Andreas Rift.
  9. Map of California, Rock Creek Quadrangle.
  10. Map of California, San Antonio Quadrangle.
  11. Map of California, Hesperia Quadrangle.
  12. Map of California, San Bernardino Quadrangle.
  18. Map of California, Redlands Quadrangle.
  14. Map of California, San Geronio Quadrangle.
  15. Map of California, San Jacinto Quadrangle.
  16. Map of the City of Santa Rosa, Sonoma County, California, showing parts destroyed by earthquake of April 18, 1906, and fire consequent thereto.
  17. Geological map of the City of San Francisco.
  18. Geological profiles with corresponding intensity curves across the City of San Francisco.
  19. Map showing distribution of apparent intensity of the earthquake shock.
  20. Map of the City of San Francisco, showing streets and burnt area, 1906.
  21. Map of California, San Mateo Quadrangle, of the U. S. Geological Survey, showing distribution of apparent intensity, known faults, and routes examined.
  22. Map of California, Santa Cruz Quadrangle, of the U. S. Geological Survey, showing distribution of apparent intensity, known faults, routes examined, and numbered localities referred to in the text.
  28. Map of California and Nevada, showing distribution of apparent intensity in region affected by the earthquake of April 18, 1906.
  24. Map of Coast Range region of Middle California, showing distribution of earth movement on April 18, 1906, as revealed by displacement of triangulation stations of the Coast and Geodetic Survey, as determined by resurvey, 1900-1907.
  25. Distribution of the earth movement on April 18, 1900, and in 1808, as revealed by displacement of triangulation stations of the Coast and Geodetic Survey, as determined by resurvey in 1900-1907.

## SEISMOGRAMS.

TABLE NII.

1. Toronto, Canada; Victoria, Canada; Baltimore, Md.; Coimbra, Portugal; San Fernando, Spain ; Pilar, Argentina; Calcutta, India; Kew, England; Paisley, Scotland; Ponta Delgada, Azores; Bidston, Phigland ; Edinburgh, Scotland ; Cape of Good Hope, Africa; Cairo, Egypt.
2. Irkutsk, Siberia (Milne instrument); Island of Mauritius; Perth, Australia; Honolulu, H. I.; Wellington, N. Z.; Kodaikanal, India; Bombay, India; Taschkent, Turkestan (Hepsold-Zöllner instrument) ; Kremsmunster, Austria.
2. a. — Irkutsk, Siberia (Repsold-Zöllner instrument); Ucele, Belgium.
8. Berkeley, Cal.; San Jose, Cal.; Yonntville, Cal.; Cleveland, Ohio; Oakland, Cal.; Los Gatus, Cal.; Alameda, Cal.; Mt. Hamilton, Cal.; Carson City, Nevada.
4. Manila, P. I.; Potsdam, Germany (Von Rebeur-Puschwitz instrument).
6. Munich, Germany; Potsdam, Germany (Wieehert }>eiiduluiii) ; Kobe, Japan.
- tj. Florence, Italy.

## SHEET NO.

7. Shide, England (heavy horizontal pendulum); Porto D' Ischia, Italy; Grande Seutinella, Italy; Pavia, Italy.
8. Washington, D. C.; Cheltenham, Md.; Albany, N. Y.; Porto Rico, W. I.
9. Vienna, Austria; Upsala, Sweden; Tacubaya, D. F. Mex.
10. Jurjew, Russia; Ottawa, Canada.
11. Sitka, Alaska; Tokyo, Japan; Jena, Germany.
12. Göttingen, Germany; Shide, England (Milne instrument, open scale); Messina, Italy.
13. Sofia, Bulgaria; Krakau, Austria; Irkutsk, Siberia (Bosch-Omori instrument); Taschkent, Turkestan (Bosch-Omori instrument); Catania, Italy.
14. Rocca di Papa, Italy; Granada, Spain; Strassburg, Germany.
15. Zi-ka-wei, Shanghai, China; Osaka, Japan; Taihoku, Formosa; Batavia, Java; Sarajevo, Bosnia; Calamate, Greece; Bombay, India (Coloba horizontal pendulum).

## THE CALIPOKNIA EAKTHQUAKE OF APEIL 18, 1906.

---

### INTRODUCTION.

On the morning of April 18, 1906, the coastal region of Middle California was shaken by an earthquake of unusual severity. The time of the shock and its duration varied slightly in different localities, depending upon their position with reference to the seat of the disturbance in the earth's crust; but in general the time of the occurrence may be stated to be 5<sup>h</sup> 12<sup>m</sup> A. M. Pacific standard time, or the time of the meridian of longitude 120° west of Greenwich; and the sensible duration of the shock was about one minute.

The shock was violent in the region about the Bay of San Francisco, and with few exceptions inspired all who felt it with alarm and consternation. In the cities many people were injured or killed, and in some cases persons became mentally deranged, as a result of the disasters which immediately ensued from the commotion of the earth. The manifestations of the earthquake were numerous and varied. It resulted in the general awakening of all people asleep, and many were thrown from their beds. In the zone of maximum disturbance persons who were awake and attending to their affairs were in many cases thrown to the ground. Many persons heard rumbling sounds immediately before feeling the shock. Some who were in the fields report having seen the violent swaying of trees so that their top branches seemed to touch the ground, and others saw the passage of undulations of the soil. Several cases are reported in which persons suffered from nausea as a result of the swaying of the ground. Many cattle were thrown to the ground, and in some instances horses with riders in the saddle were similarly thrown. Animals in general seem to have been affected with terror.

In the inanimate world the most common and characteristic effects were the rattling of windows, the swaying of doors, and the rocking and shaking of houses. Pendant fixtures were caused to swing to and fro or in more or less elliptical orbits. Pendulum clocks were stopt. Furniture and other loose objects in rooms were suddenly displaced. Brick chimneys fell very generally. Buildings were in many instances partially or completely wrecked; others were shifted on their foundations without being otherwise seriously damaged. Water or milk in vessels was very commonly caused to slop over or to be wholly thrown from the vessel. Many water-tanks were thrown to the ground. Springs were affected either temporarily or permanently, some being diminished, others increased in flow. Landslides were caused on steep slopes, and on the bottom lands of the streams the soft alluvium was in many places caused to crack and to lurch, producing often very considerable deformations of the surface. This deformation of the soil was an important cause of damage and wreckage of buildings situated in such tracts. Railway tracks were buckled and broken. In timbered areas in the zone of maximum disturbance many large trees were thrown to the ground and in some cases they were snapt off above the ground.

The most disastrous of the effects of the earthquake were the breaking out of fires and, at the same time, the destruction of the pipe systems which supplied the water necessary to combat them. Such fires caused the destruction of a large portion of San Francisco, as all the world knows; and they also intensified the calamity due to the earthquake at Santa Rosa and Fort Bragg. The degree of intensity with which the earthquake made itself felt by these various manifestations diminished with the distance from the seat of disturbance, and at the more remote points near the limits of its sensibility it was perceived only by a feeble vibration of buildings during a brief period.

The area over which the shock was perceptible to the senses extends from Coos Bay, Oregon, on the north, to Los Angeles on the south, a distance of about 730 miles; and easterly as far as Winnemucca, Nevada, a distance of about 300 miles from the coast. The territory thus affected has an extent, inland from the coast, of probably 175,000 square miles. If we assume that the sea-bottom to the west of the coast was similarly affected, which is very probably true, the total area which was caused to vibrate to such an extent as to be perceptible to the senses was 372,700 square miles. Beyond the limits at which the vibrations were sufficiently sharp to appeal to the senses, earth waves were propagated entirely around the globe and were recorded instrumentally at all the more important seismological stations in civilized countries.

The various manifestations of the earthquake above cited, including the cracking and deformation of the soil and incoherent surface formations, were the results of the earth jar, or commotion in the earth's crust. The cause of the earthquake, as will be more fully set forth in the body of this report, was the sudden rupture of the earth's crust along a line or lines extending from the vicinity of Point Delgada to a point in San Benito County near San Juan; a distance, in a nearly straight course, of about 270 miles. For a distance of 190 miles from Point Arena to San Juan, the fissure formed by this rupture is known to be practically continuous. Beyond Point Arena it passes out to sea, so that its continuity with the similar crack near Point Delgada is open to doubt; and the latter may possibly be an independent, tho associated, rupture parallel to the main one south of Point Arena. It is most probable, however, that there is but one continuous rupture. The course of this fissure for the 190 miles thru which it has been followed is nearly straight, with a bearing of from N. 30° to 40° W., but with a slight general curvature, the concavity being toward the northeast, and minor local curvatures. The fissure for the extent indicated follows an old line of seismic disturbance which extends thru California from Humboldt County to San Benito County, and thence southerly obliquely across the Coast Ranges thru the Tejon Pass and the Cajon Pass into the Colorado Desert. This line is marked by features due to former earth movements and will be referred to in a general way as a *rift*, the term being adopted from the usage for analogous features in Palestine and Africa.<sup>1</sup> To distinguish it from other rifts of similar origin, it will be referred to more specifically as the San Andreas Rift, the name being taken from the San Andreas Valley on the peninsula of San Francisco, where it exhibits a strongly pronounced character and where its diastrophic origin was first recognized in literature.

The plane or zone on which the rupture took place is, so far as can be determined from a study of the surface phenomena, nearly vertical; and upon this vertical plane there is a horizontal displacement of the earth's crust or at least of its upper part. The displacement was such as to cause the country to the southwest of the rift to move relatively to the country on the northeast side of that rift. The differential displacement in a horizontal direction was probably not less than 15 feet for the upper part of the Rift; in many places it measured over 15 feet, and in some places as much as 21 feet.

<sup>1</sup> H. y. Oograph. Sue. v. 1. iv, 4, 1894. The Great Rift Valley, by J. W. Gregory, London, 1896.

This differential displacement of the earth's crust along the plane of rupture constitutes & *fault*, and will be so referred to in the text of the report. It is named the San Andreas fault. The intersection of the fault plane or narrow zone with the surface of the ground is manifested by cracks, heaved sod, scarps, etc., and these manifestation<sup>^</sup> are designated the *fault-trace*. As a result of this fault, all the fences, roads, railways, bridges, tunnels, dams, pipes, and other structures which cross its path were dislocated. All property lines and other survey lines which were intersected by it were offset. Inasmuch as the movement of the earth which caused the fault was not confined to its immediate vicinity, but was distributed over a considerable belt of country on either side of the trace of the rupture, the latitudes and longitudes of a large portion of the Coast Ranges of California were changed, and the triangles established by the Coast and Geodetic Survey in its triangulation of the region were distorted.

In addition to the horizontal displacement there was, particularly toward the northern end of the fault, a vertical displacement probably nowhere exceeding 2 to 3 feet, whereby the country to the southwest was raised relatively to that to the northeast. In many places, however, particularly toward the southern end of the fault, no vertical displacement can be detected; and there is some indication that, if there was vertical displacement in this region, it was the reverse of that observed in the northern portion of the fault. This rupture of the earth's crust gave rise to certain manifestations at the surface which resemble those described above as a result of the vibratory commotion of the earth, due to the sudden displacement. The cracking and rending of the surface along the line of the fault is a direct expression of the rupture and displacement which originated the earthquake, whereas the cracks, fissures, and lurching of the soft bottom lands and the landslide cracks on the hillsides, whether near the fault line or remote from it, are referable to the oscillation of the crust. The two classes of phenomena must, therefore, be discriminated, particularly<sup>^</sup> as there has been a tendency on the part of some observers to class the secondary phenomena with the primary and interpret the former as indicative of fault lines in the earth's crust, when in reality they are merely superficial phenomena\*

While the shock was perceptible to the senses to the extent above indicated in California, Nevada, and Oregon, the distribution of the higher grades of intensity was remarkably linear and was definitely related to the fault line, and to the general trend of the coast of California. This may be brought out in a preliminary way by stating that a zone of destructive effects extends parallel to the Rift from Humboldt Bay, in Humboldt County, to the vicinity of King City in Monterey County, a distance of 350 miles. If we take the throw of brick chimneys and allied phenomena as indicating the limits of what may be called destructive effects, the width of this zone may be fairly approximated at about 70 miles, or about 35 miles on either side of the fault, or its prolongation where no actual fault is observable at the surface. The length of this zone of destruction is thus five times greater than its width, and the total area within which the shock was sufficiently severe to throw brick chimneys may be placed at something over 25,000 square miles; it being assumed that the severity to the southwest of the fault, beneath the waters of the Pacific, was equal to that on the land. If the fault near Point Delgada be regarded as distinct from that extending from Point Arena southeasterly, then the total area of these high intensities would be considerably larger in the direction of the Pacific.

Within this outer limit of destructive effects the intensity increased toward the fault. But proximity to the fault was not the only factor determining the degree of intensity. The soft, more or less incoherent, and water-saturated alluvial formations of the valley-bottoms were much more severely shaken than the rocky slopes of the intervening ridges, and the structures upon them were consequently more commonly and more completely wrecked. It is not understood by this excessive damage on the valley-

bottoms that the vibratory movement due to the passage of the earth-wave was characterized by greater energy than where it traversed elastic rocks; but that this energy was manifested in a form of movement more destructive to structures upon the surface. The intensity of the shock upon the valley-bottoms, as inferred from damage, seemed abnormally high. In terms of energy it was probably not abnormal. It thus became necessary to discriminate between *apparent intensity* and *real intensity*. Inasmuch as we have to deal primarily with observable effects and record these as a basis for inference, it has been found convenient to use the term "apparent intensity" in a technical sense thruout the report; and all the grades of intensity specified, even when the qualification "apparent" is omitted because of the wearisomeness of its reiteration, are grades of "apparent intensity" arrived at by applying literally the criteria of the Rossi-Forel scale.



## GEOLOGY OF THE COAST SYSTEM OF MOUNTAINS.

---

### DEFINITIONS.

In common with many other mountainous tracts the world over, the Coast System has limits which are difficult of precise definition. The criteria which serve to discriminate one tract from another are various and have different values in different cases. Any attempt at precise definition must be more or less arbitrary. An outline of the extent and subdivisions of the system will, however, be presented in summary fashion.

On the north the Coast System extends to the northern end of Humboldt County, and in that county and in southern Trinity County the last typical ridge is South Fork Mountain. This is a remarkably linear ridge beginning near the coast and extending with a northwest-southeast course to the vicinity of North Yallo Bally Mountain. Beyond South Fork Mountain to the northeast lie the Klamath Mountains, a group more nearly allied in the history of its uplift and in its constituent rocks to the Sierra Nevada than to the Coast Range. On the south the Coast System is sometimes regarded as ending in Santa Barbara County; and the mountains of Southern California; thence east-southeast and south to the Mexican boundary, are regarded as a distinct system, being viewed as a northerly prolongation of the orographic axis of the peninsula of Lower California. The chief consideration favoring this distinction is the change in trend of the mountain ridges, which becomes apparent just north of the Santa Barbara Channel. Other facts favor this discrimination, such as the prevailing absence of the Franciscan formations in the mountains of southern California and the greater abundance of granitic rocks; but more especially the greater incisiveness of the structural lines, indicating, on the whole, more intense orogenic action. But these considerations are largely offset by the unmistakable continuity of the tectonic lines of the northern ranges into the mountains of southern California, and by the fact that the movements to which their larger features are due date from the close of the Tertiary. It would seem, therefore, that there is sufficient unity of character in these coastal mountains, in spite of their change of trend, to warrant their being classed as the Coast System from South Fork Mountain south to the Mexican boundary and beyond. That term may be used in a comprehensive sense, significant of the genetic and structural unity which runs thru them.

It will nevertheless be very convenient to recognize three subdivisions of the Coast System thus outlined. The first of these subdivisions extends from South Fork Mountain on the north to the Valley of the Cuyama River on the south, and may, in accordance with popular usage, be referred to simply as the Coast Ranges, the term "system" being used only when it is intended to express the more comprehensive view. The second subdivision is a broad chain extending from Santa Barbara County to the far side of the Colorado desert with a general trend of west northwest-east southeast, and including the San Rafael, Santa Ynez, Santa Susannah, Santa Monica, San Gabriel, and San Bernardino Ranges, and also, perhaps, the Chocolate Range. This chain is sometimes referred to as the Sierra Madre, tho the full application of the term in popular usage is not clear. The third subdivision embraces the mountainous country south and southeast of the valley of Southern California, the principal ranges of which are the Santa Ana and the San Jacinto. These have the northwest-southeast trend of the Coast Ranges and, in accordance with the suggestion of some of the earlier writers on Californian geology, may be referred to as the Peninsular chain.

## GEOLOGICAL HISTORY.

The Coast Ranges of California have had a long and varied geological history. Their structure is complex and the sequence of formations differs at different points. Several of the more important groups of sedimentary rocks contain, so far as known, but few fossils or none at all. Only in recent years have the topographic maps necessary for an adequate study of the stratigraphy and structure of the region become available, and then only for limited areas. Nevertheless the general outlines of the geology of the Coast Ranges are known, and in some of the localities which have been topographically mapped, a considerable body of detailed information is at hand.

The oldest sedimentary rocks of the Coast Ranges are of unknown age. They comprise impure and somewhat magnesian limestone, quartzites, and various crystalline schists. The limestones are usually in the form of coarse marble varying in color from dark gray to white and containing frequently some graphite and less commonly lime silicate. The quartzites are thoroly indurated, as a rule, sometimes to the extent of being vitreous, and usually show well-marked stratification. The schists have as yet been little studied, and no adequate observations upon their character in detail have been put on record. They are known, however, to comprise both micaceous and hornblendic varieties.

These marbles, quartzites, and crystalline schists are known only in more or less fragmentary form, associated with considerable bodies of granitic rocks which have invaded them as batholiths. The most common occurrence of the marbles, quartzites, and schists is in the form of limited belts and isolated patches embedded in the granitic rocks, or in limited areas flanking the margins of the batholiths, and showing evidence of contact metamorphism. It is evident in most cases, and is probably generally true, that the granite of the Coast Ranges is of later date than the metamorphic sedimentary rocks associated with them. While the age of these pregranitic sedimentary formations is at present unknown, the age of the granite is suggested by its seeming identity with the granite of the Sierra Nevada. The latter is a vast batholith known to be intrusive in Paleozoic and Mesozoic strata as late as the Upper Jurassic. This granite has been followed thru the Sierra Nevada to Tehachapi and Tejon Pass, where the range curves sharply around and passes into the Coast Ranges. Passing northerly thru the Coast Ranges, granite identical in character with that of the Sierra Nevada, and carrying identical inclusions of older sedimentary rocks, is traceable in more or less extensive areas from the upper reaches of the Cuyama River to Bodega Head on the coast north of the Golden Gate. It thus seems probable that the granite of the Coast Ranges, like that of the Sierra Nevada, is of late Jurassic or post-Jurassic age. The granitic rocks of the Coast Ranges, together with the pregranitic rocks into which they are irruptive, constitute a complex which is thus the probable analogue of the Bedrock Complex of the Sierra Nevada.

This Coast Range Complex was subjected to vigorous erosion and then submerged to serve as the sea floor upon which the series of rocks known as the Franciscan was deposited. This series consists for the most part of medium coarse, dark gray or greenish-gray sandstone, strongly indurated, with subordinate shales and conglomerates. Intercalated with these sandstones are important horizons of foraminiferal limestone and radiolarian chert and admixtures of volcanic rocks, chiefly basaltic in character. In the vicinity of the Bay of San Francisco, where the series is best known, it falls into seven stratigraphic divisions. These are in ascending order:

- (1) A group of arkose sandstones with some conglomerates and shales reposing unconformably upon the Montara granite and with an aggregate thickness of about 800 feet.
- (2) A formation of light-gray, very compact and fine-textured foraminiferal limestone ranging in thickness from about 60 to possibly a few hundred feet.

- (3) Sandstones aggregating 2,000 feet in thickness.
- (4) A formation of radiolarian cherts from 100 to 900 feet.
- (5) Sandstone, 1,000 feet.
- (6) Radiolarian cherts, 500 feet.
- (7) Sandstone, 1,400 feet.

In this sequence of sedimentary strata, particularly toward its upper part, there are intercalated lavas at various horizons.

After their accumulation, but before the next higher series of rocks was deposited upon them, the Franciscan strata were invaded by intrusive rocks at points so numerous and so widespread thruout the Coast Ranges that these intrusive bodies constitute one of their most characteristic associations, in contrast to the series which succeed them. The intrusive rocks are of two general types. One is a highly magnesian rock, usually a peridotite, but with facies of pyroxenite and gabbro, the peridotite being generally almost completely serpentized. The other is a basaltic rock grading into diabase and having in many of its occurrences the peculiar structure characteristic of the spheroidal basalts. In addition to the spheroidal structure on the gross scale, it is in some cases variolitic. Associated with both of these intrusives are areas, generally of limited extent and sporadic distribution, of glaucophane and other crystalline schists, which appear, where they have been most thoroly studied, to be the result of a peculiar kind of contact metamorphism.

The stratigraphic composition of the Franciscan series indicates an interesting to-and-fro migration of the shore line of that time, probably due to a vertical oscillation of the continental margin. The basal group of sandstones, shales, and conglomerates is clearly a terrigenous deposit laid down in proximity to the margin of the continental area from which the sediments were derived. The next succeeding formation, the foraminiferal limestone, on the contrary, is nonterrigenous. Its character as nearly pure carbonate of lime, except for the flinty lenses and nodules it contains, and the abundance of foraminifera, indicates that the sea-bottom over the present position of the San Francisco Peninsula was too remote from the shore to receive an admixture of sand or clay. That is to say, the conditions which favored the deposition of the limestone were inaugurated by a withdrawal of the shore line from the position which it occupied during the deposition of the underlying sandstones. And this lateral migration of the shore was doubtless the result of a sinking of the coast.

Above the foraminiferal limestone sandstones again occur, indicating a return of the shore to about its former position, doubtless due to an uplift of the sea-bottom and coast. These sandstones are in turn followed by a nonterrigenous formation of radiolarian cherts. These are for the most part flinty rocks containing abundant remains of radiolaria, marine organisms which secrete a siliceous test instead of a calcareous one, as in the case of the foraminifera. They contain no admixture of sand, and the shaly partings which separate the layers of chert are very doubtfully referable to land waste. Here again the sea bottom must have been depressed and the shore line caused to withdraw. These radiolarian cherts are followed again by sandstones, and these by a second formation of radiolarian cherts, the former as before indicating uplift of the sea-bottom and the latter depression. The last movement in Franciscan time was uplift, indicated by the sandstones, which rest upon the second horizon of radiolarian cherts and which constitute the topmost formation of the Franciscan series.

The age of the Franciscan is not positively known. Certain general considerations, however, contribute data upon which a tentative judgment as to this question may be based. Stratigraphically, the Franciscan lies upon the eroded surface of the Coast Range granites, the correlation of which with the post-Jurassic granites of the Sierra Nevada has been suggested. If such correlation be adopted, the age of the Franciscan must be

post-Jurassic. On the other hand, the Franciscan is clearly pre-Knoxville; and the Knoxville has usually been regarded as the local base of the Cretaceous. Fossils are scarce in the Franciscan, but such fragmentary forms as have thus far been found point to a Cretaceous age. It would seem not improbable/ therefore, that the Franciscan represents a pre-Knoxville division of the Cretaceous, which has not as yet been recognized in the geological scale. The question, however, requires further investigation before a final decision can be reached.

After the accumulation of the Franciscan strata as thus characterized, and perhaps in connection with the invasion of the series by peridotitic and basaltic intrusives, the region was folded and broken, and elevated within the zone of erosion. The elevatory movement was probably quite general. The Franciscan, while subjected to general denudation, was probably nowhere stripped down to the underlying basal complex before it was submerged to receive the next succeeding sedimentary strata. These comprize the Knoxville formation, consisting wholly of shales and sandstones with quite subordinate layers and lenses of limestone, all in very regular and rather thin strata, significant of deposition in a shallow basin under fluctuating conditions of transportation. The Knoxville varies in volume from a few hundred to several thousand feet and is widely distributed over the Coast Ranges. It is succeeded in the vicinity of the Bay of San Francisco, and to a less marked degree in other parts of the Coast Ranges, by a formation of coarse conglomerate known as the Oakland conglomerate. This conglomerate attains a thickness of over 1,000 feet in places and follows the Knoxville shales in apparently conformable sequence. The change in the character of the deposits from shales to coarse conglomerates, without any interruption in the continuity of sedimentation, suggests an orogenic disturbance of the margins of the basin within which the Knoxville beds were accumulating, whereby the grades of the streams were greatly accentuated and the degradation of the continental region correspondingly accelerated.

The Oakland Conglomerate, or, where that is missing, the Knoxville shale, is directly followed by a formation of thick bedded sandstones and shales known as the Chico formation. It has a thickness in places of many thousands of feet. The entire volume of strata, from the base of the Knoxville to the top of the Chico, is usually referred to as the Shasta-Chico Series, the Shasta comprizing the Knoxville and Oakland formations, together with certain other paleontological subdivisions not here particularly mentioned. The series is remarkable for its great volume. In the northern Coast Ranges to the west of the Sacramento Valley, the thickness of the sedimentary section, comprizing practically only sandstones and shales, is as much as 29,000 feet. This vast accumulation of strata clearly signifies the development of a great geosyncline, or depression of the sea-bottom in that region in which deposition kept pace with subsidence thruout this portion of Cretaceous time. The Shasto-Chico series is usually regarded as comprizing the whole of the California Cretaceous, but the considerations cited above in regard to the Franciscan indicate that the latter may perhaps be included in the lower Cretaceous section of this region.

The movements which brought the Mesozoic to a close and inaugurated the Tertiary in the Coast Range region were not those of violent orogenic deformation such as characterize this period of geological time in many other parts of the world; but were rather of the nature of a partial elevation of the region, with quite gentle deformation, resulting in a notable restriction of the basin of deposition. The earliest Eocene strata show no marked structural discordance with the Chico. It is nevertheless very probable that a notable unconformity exists, since the abundant and characteristic Cretaceous fauna disappeared and was supplanted by an almost totally distinct assemblage of life forms. The Eocene of the California Coast Ranges falls into two paleontologically distinct groups which have been classed together as the Karquines series. The lower of these

comprizes about 2,000 feet of sandstones, portions of which are green sands, together with some shales. These make up the Martinez group. Its distribution, so far as known at present, is quite limited and is confined to the middle Coast Ranges on their eastern side, between Clear Lake and Mount Diablo. The upper division of the Karquines is known as the Tejon group, and comprizes also about 2,000 feet of sandstones, often somewhat ferruginous and weathering reddish, but very strongly cemented. The Tejon strata are apparently conformable upon the Martinez, but the sharp contrast in the faunal contents of the two groups suggests rather widespread physiographic changes at the close of the Martinez which may be regarded as indicative of unconformity. The Tejon strata are much more widely distributed than the Martinez, a fact which suggests the enlargement of the Karquines basin of deposition by subsidence of the coast during the progress of Eocene time.

The next succeeding group of rocks, belonging to the Oligocene division of the Tertiary, has been named the San Lorenzo Formation.<sup>1</sup> It is known in Santa Cruz County, where it attains a thickness of 2,300 feet, made up chiefly of gray shales and fine sandstones. Its stratigraphic relations to the Tejon are not yet known, but its fauna is said by Arnold to contain many species which appear to be closely related to Tejon forms. It may thus be considered as following the Tejon conformably. It is in certain sections known to be unconformable beneath the oldest formation of the Miocene, known as the Vaqueros Sandstone, indicating that after the deposition of the San Lorenzo formation, the region of the Coast Ranges was disturbed and uplifted into the zone of erosion; and the following facts regarding the transgression of the Miocene Sea indicate that this uplift was a very extensive one. Such an uplift in time immediately preceding the Miocene is further indicative of a much closer relationship between the San Lorenzo and the Tejon than between the former and the Monterey.

Miocene time in the Coast Range region was characterized by a progressive subsidence with oscillations of the coast. The Miocene sea gradually transgressed the continental margin from the southwest, and as it did so spread a formation of arkose sands and conglomerates over the greater part of the southern Coast Ranges. This was followed, as the water deepened with progressive subsidence, by a remarkable deposit of bituminous shales. These shales are usually whitish or cream-colored, tho often of a purplish or other dark tint, and may be either of a soft chalky consistency, or opaline, or hard and flinty. It is thruout an essentially siliceous formation and is largely diatomaceous in character, tho more or less admixt with volcanic pumiceous ash. In some portions the ash is a prominent constituent, and in San Luis Obispo County there is a deposit aggregating about 1,000 feet in thickness of well-stratified volcanic tuff and agglomerate. In San Mateo County there are basalts which were erupted at this period. Interstratified with these siliceous shales, thin beds of more or less ferruginous and somewhat magnesian limestones are by no means uncommon. They are, however, lenticular or non-persistent, and are of a very compact texture and usually nonfossiliferous. There are also in some places thin but persistent beds of a peculiar, very hard, fine-grained, light-colored sandstone intercalated with the shales. In the southern portion of the Coast Ranges the bituminous shales accumulated to a thickness of several thousand feet, but in the middle Coast Ranges, in the vicinity of the Bay of San Francisco, the Miocene sea was characterized by an oscillatory or to-and-fro migration of its eastern shore line, due to alternate uplift and subsidence of the coast, quite analogous to that described for the Franciscan period. This gave rise to an alternation of shallow water in which sandstones were deposited, and deep water in which siliceous ooze accumulated with but little admixture of terrigenous material. We have thus in the territory between Mount Diablo and the Bay of San Francisco an alternation of four formations of bituminous

---

<sup>1</sup> Arnold, U. S. G. S. Professional Paper No. 47, p. 16.

shale with five formations of sandstone, the latter being at the bottom and top of the series. The series is known as the Monterey series, and its various members have distinctive formational names. While the oscillation of the coast so clearly recorded in the strata near the Bay of San Francisco is not apparent in the southern Coast Ranges, it is by no means certain that they were not affected in a similar way. The vertical movement involved was not great, and such a movement might have extended over the deeper portions of the area of deposition in Monterey time without effecting a sufficient change in the depth of the water to alter the character of the sediments. The Monterey sea apparently did not, even at the time of its maximum transgression, extend far over the region of the northern Coast Ranges, and a line drawn from Tehachapi to Cape Mendocino would probably represent the general position of the shore at the close of Monterey time.

At the close of the Miocene, the Coast Range region was disturbed by orogenic movements and uplifted into the zone of erosion. It was then depressed irregularly so as to give rise to local basins of sedimentation in which accumulated great thicknesses of Pliocene beds, particularly about the Bay of San Francisco and southward. The oldest of these Pliocene formations is the San Pablo, which lies unconformably upon the Monterey strata. This is essentially a sandstone formation with a thickness of from 1,000 to 2,000 feet. It occurs on both sides of the Coast Ranges from the vicinity of the Bay of San Francisco southward and appears to have been laid down in two basins, separated by a barrier corresponding to the general axis of the present Coast Ranges. The formation on the east side of the range is characterized by a notable admixture of dark andesitic ash, which gives the unweathered exposures of the sandstones a distinctly blue color. This formation has a fauna of over 100 species, of which more than 40 per cent are living forms. This fact, and the unconformable superposition of the formation upon the Monterey, are warrant for placing it in the Pliocene. On the west side of the Coast Ranges, the San Pablo is best known in San Luis Obispo and Santa Barbara Counties, and is there free from volcanic admixtures, though the basal beds are very commonly characterized by the presence of asphaltum, which cements the sand together and constitutes the well-known bituminous rock of the region. This asphaltum appears to have originated in part as a seepage from the upturned bituminous shale of the Monterey along the shores of the San Pablo sea, and molluscan remains of San Pablo age are often embedded in it.

Succeeding the San Pablo, but nowhere, so far as the writer is aware, reposing directly upon it, is the Merced series. The sediments composing this series were laid down in rather acute geosynclinal troughs, resulting from orogenic deformation of the coast in middle Pliocene time. Three of these troughs are known. The most northerly is that now occupied by the Valley of the lower Eel River in Humboldt County; the second is largely occupied by the Santa Rosa Valley in Sonoma County; the third is on the Peninsula of San Francisco, extending thence south to the coast of Santa Cruz County. The Merced strata in the Valley of the lower Eel River, and the typical Merced section near San Francisco, show each a thickness of something over a mile. In Sonoma County the marine Merced beds grade eastward into fluvial conglomerates, admixed with volcanic ashes. The maximum thickness is about 3,500 feet. The lower part of the series is here characterized by a considerable volume of white volcanic pumiceous tuffs, which thin out rapidly to the westward. These were in part laid down directly on a land surface, burying forests of huge sequoia, whole trees being now completely silicified.<sup>1</sup> On the coast of Santa Cruz County, the series is represented by strata of lower stratigraphic horizons than nearer San Francisco, these lower beds having been called the Purissima formation, although the sedimentation was continuous with that of the Merced. The

<sup>1</sup> For description of the Merced beds of Sonoma County and the underlying pumiceous tuff, a paper by V. C. Osmond, Bull. Dept. Geol., Univ. Cal., vol. 4, No. 3, should be consulted.

lower horizon of the beds on the Santa Cruz Coast, as compared with the beds nearer San Francisco, indicates a transgression of the Merced sea from the south. The upper portion of the Merced section contains so large a proportion of molluscan remains of existing species that it has been regarded by Arnold as Pleistocene rather than Pliocene.

The accumulation of the Merced series to the great thickness above indicated in middle and northern California proves local depressions of the coast of over a mile below sea level in later Pliocene time. Similar orogenic deformation was in progress at the same time on the eastern side of the barrier corresponding to the then axis of the Coast Ranges. These movements gave rise to great troughs from which the sea was excluded, but which were occupied by fresh water, and filled with sediments equal in volume to those of the marine troughs to the west of the barrier. The greater part of these fresh-water beds are comprized in the Orindan formation, which may be the equivalent of the Cache Lake beds of the Clear Lake district \* and of the Paso Robles in the southern Coast Ranges. They have an extensive distribution on the eastern side of the Coast Ranges, and in the vicinity of the Bay of San Francisco there intervenes between the base of the Orindan and the San Pablo a formation of white pumiceous tuff entirely similar to that at the base of the Merced series in Sonoma County, but containing here fresh-water fossils. This tuff attains a maximum thickness of about 1,000 feet and is known as the Pinole tuff. Thruout the Orindan there are occasional intercalated strata of volcanic tuff of moderate thickness. The Orindan lacustrine period was brought to a close in the region of the middle Coast Ranges by volcanic eruptions which resulted in extensive flows of lava and showers of ashes. Upon these lavas lake basins were later established and some hundreds of feet of fresh-water deposits (Siestan formation) accumulated in them, which were in turn buried by other lavas.

The accumulation of the Merced marine beds and the corresponding lacustrine and volcanic rocks was brought to a close by an acute and widespread deformation regarded as part of the general mountain-making movements which ushered in the Pleistocene in western North America. As a result of these movements, the Merced and Orindan basins were folded and faulted, and the basement upon which their contained strata had been laid down was lifted in part from a position over a mile below sea-level to one far above sea-level. The Pliocene formations were brought within the zone of active erosion and the evolution of the present geomorphic features of the Coast Ranges was inaugurated. When the degradation of the folded Orindan strata was well advanced, a lake basin was established across the edges of these strata and in it accumulated the various fresh-water beds and volcanic lavas and tuffs comprizing the Campan series. At a time within the Pleistocene when the geomorphic evolution of the coast had been well advanced to its present condition, the coastal belt was deprest 1,000 to 2,000 feet lower than it is at present, and then uplifted in stages marked by marine terraces along many parts of the coast. Since this there have been oscillations of the region about the Bay of San Francisco, the net result of which has been a depression allowing the sea to invade the valleylands and thus make the magnificent harbor to which San Francisco owes its existence.

In the foregoing sketch of the formations of the Coast Ranges and their historical significance, it is desired to emphasize particularly the remarkable series of subsidences and uplifts which have affected the coastal region from the beginning of the Franciscan to the present. This record of oscillation is in marked contrast to the comparative stability of the Sierra Nevada. Except for a marginal strip of its foot-hill slopes, the region of the present Sierra Nevada has not been submerged beneath the sea. During the geological ages in which the Coast Range region has been repeatedly deprest to receive marine sediments, the sum of the maximal sections of which amounts to 65,000 feet of strata, the western edge of the Sierra Nevada region has probably never been

---

<sup>1</sup> Described by G. F. Becker, U. S. G. S. Monograph x m, pp. 219-221, 238-242.

depress over 1,000 feet. The geological record for the latter region is in terms of degradation rather than of deposition; and such deposits as have here accumulated are referable wholly to fluvial, lacustral, and volcanic agencies. It is thus apparent that from the point of view of the stability of the earth's crust, the Coast Range region has been very much more mobile than the Sierra Nevada. The long comparative stability of the latter was, it is true, interrupted at the close of the Tertiary by a very notable uplift, whereby it took the form of a tilted orographic block of great size and remarkable unity; but this does not detract from the force of the contrast. The difference in behavior with respect to crustal stability makes the Coast Ranges a totally distinct and different geological province from the Sierra Nevada.

Between these two strongly contrasted provinces lies the great valley of California, one of the very notable geomorphic features of the continent. This valley is but one of a long series of similar depressions which lie along the western border of the North American continent, between the coastal uplands and the western edge of the continental plateau. In the north it has its probable analogues in Hecate Strait, the Gulf of Georgia, Puget Sound, the Willamette Valley, the Ashland Valley, and the depression between the Sierra Nevada and the Klamath Mountains. On the south we see its analogues in the Colorado Desert, the Gulf of California, and in the valley which lies between the southern border of the central plateau of Mexico and the Sierra Madre del Sur. In the Californian region we must interpret the axial line of this depression as a tectonic hinge, upon which the mobile coastal region has swung in a vertical sense upon the edge of the interior plateau, here represented by the Sierra Nevada. Whether this tectonic hinge is a more or less flexible zone upon which movement has taken place without rupture, or whether it represents a zone of dislocation, is not clear; but that differential movement has taken place along the valley line is one of the salient facts in the geological history of California.

#### STRUCTURE.

A detailed account of the structure of the Coast System would involve a discrimination between features referable to the different orogenic movements which have affected the region at various periods of its history. Owing to this succession of movements, new structures have been superimposed upon older structures, or upon remnants of older structures, so often that the resultant effect is extremely complicated and not only difficult to unravel but difficult to state or describe in any simple way. In this summary review of the subject, no such detailed discrimination will be attempted. The only effort will be to call attention to the salient features, which are for the most part referable to the orogenic movements of later Tertiary and post-Tertiary time.

*Marginal Features.* — In a consideration of the structural features of the Coast System, its marginal lines on the east and west first claim attention. The eastern slope of the Coast Ranges rises from the floor of the Great Valley much more abruptly in general than does the western slope of the Sierra Nevada from the same valley floor. Turner<sup>1</sup> has suggested that the Great Valley east of the Coast Ranges is determined by a fault. There is some warrant for this view and it is certainly true in part. The very precipitous mountain front which rises from the valley at its southern end is without doubt a degraded fault-scarp, tho whether or not this fault or a series of similar faults can be followed along the edge of the mountains to their northern end is questionable. It is, however, safe to say that the eastern margin of the Coast Ranges represents a line of acute deformation, with the probability of that deformation having taken the form of faults in certain places. No one has yet made a sufficiently careful study of the question to make a more precise statement possible. In general, this line of acute deformation is not

<sup>1</sup> Am. Geologist, vol. xm, p. 248.



straight, but is curved, with the concavity toward the northeast. Between the southern end of the valley and the vicinity of Coalinga its course is about N. 35° W. From Coalinga, where there is an offset or jog in the general trend north to Tracy, the course is about N. 30° W. From Tracy to Suisun there is a marked westerly embayment in the Coast Ranges which is probably due, in part at least, to the depression of the region about the Bay of San Francisco. From Suisun northward to the vicinity of Red Bluff the general course of the margin of the Coast Ranges is north and south. At Tejon Pass the eastern margin of the Coast System receives the abutment of the southern end of the Sierra Nevada; thence southward, with a course swinging more easterly, it determines the southwest limit of the Mojave Desert.

On the seaward side the Coast System is usually regarded as being limited by the shore line. The precipitous coast rising to elevations of from 2,000 to 5,000 feet, extending from Cape Mendocino to Point Conception, and the popular notion that mountain ranges are confined to the land areas of the earth, are justification for this view. But in a more comprehensive view, embracing all inequalities of the earth's surface both above and below the sea-level, the western margin of the mountainous area, the familiar portions of which we call the Coast System, will have to be placed farther seaward. Off the coast of California the sea-bottom slopes down to the 3,000-foot submarine contour at a moderate angle and then plunges steeply to depths of over 12,000 feet. Beyond the foot of this steep slope the sea-bottom has very flat gradients and the 15,000-foot contour is far out to sea. From the Oregon line to Point Conception the 3,000-foot submarine contour, or the brink of the steep slope, lies off shore at a distance of from 15 to 35 miles; but at Cape Mendocino and at the Bay of Monterey this line is found much closer in. South of Point Conception this steep slope has the same general trend as to the north. That is to say, it shows no embayment in its course corresponding to that at the Santa Barbara channel and southward. This is particularly true of the course of the 6,000, 9,000, and 12,000-foot contours. The slope is by no means uniform for its entire length. From Point Arena to the latitude of the Golden Gate the grade is notably steep from the 3,000 foot to the 9,000-foot contour. This is also true off Point Conception. From the latter point southeastward the steep portion of the slope is from the 6,000-foot to the 12,000-foot contour; and the same statement holds for the slope off San Simeon Bay. In general, the steepest profile lies between the 6,000 and the 9,000-foot line.

This steep drop from the subcontinental platform to the broad floor of the Pacific must be regarded as the geomorphic expression of a rather acute deformation of the earth's crust, and those portions of the slope where the contours are crowded together, as for example between Point Arena and the latitude of the Golden Gate, off San Simeon Bay, off Point Conception, and off the platform of the Channel Islands, can scarcely be interpreted as other than fault-scarps. The slopes at the localities mentioned are quite comparable to the great fault-scarp which forms the eastern front of the Sierra Nevada. At the base of the slope off the Channel Island platform, the recent dredging operations of the *Albatross* brought up from a depth of 12,000 feet numerous fragments of rock similar to the bituminous shale of the Monterey series of the southern Coast Range. With this rock was found much asphaltum. This indicates that at the base of the slope there are talus accumulations of so recent a date that they have not yet been buried by oceanic sediments.

This line of acute deformation of the crust off the entire length of the coast of California can not be ignored in any consideration of the orographic features of the region. The slope referred to is doubtless devoid of those sculptural features characteristic of mountains within the zone of erosion, and which we are too apt to look upon as essential, but it constitutes nevertheless a notable mountain front rising from the floor of the Pacific. It is the natural western boundary of the mountainous tract which we call the

Coast System. The course of this mountain from its curvature, with convexity to the Pacific, observable in the Coast Ranges, in the Great Valley of California, and in the Sierra Nevada. This convexity toward the Pacific is, it may be observed in passing, characteristic of the dominant tectonic lines about the border of that great ocean. It is very marked in the Aleutian belt, in Kuriles, in the Japanese Isles, in the festoon extending from Formosa thru the Philippines, the Moluccas, and Java to Sumatra, which is convex to both the Pacific and the Indian Oceans; and in the chain including the Salomon Islands, the New Hebrides, and New Zealand. It is also apparent in the trend of the Sierra Madre Occidental and Sierra Madre del Sur of Mexico, and in the course of the Andes thru Colombia, Ecuador, and Peru.

Having indicated the east and west boundaries of the Coast System as their dominant structural lines, we may now consider those features which pertain to the internal structure of the mountain tract. Here we must first take note of the coast line. The coastal slope of California characteristically rises abruptly from sea level to elevations of from 2,000 to 5,000 feet within a short distance from shore, from Cape Mendocino to Point Conception, with certain notable breaks in its continuity which are susceptible of special explanation. If along the shore line at the base of this abrupt slope we draw straight lines which are tangent to the headlands or chords to the minor embayments of the coast, these lines fall into two fairly constant orientations and clearly bring out the fact that the shore line has in reality a zigzag course, due apparently to the alternate control of two systems of structural lines, one of which is between N. 37° W. and N. 40° W., and the other between N. 10° W. and N. 15° W., thus intersecting at an angle of about 26°. Under this scheme of discrimination of the orientation of different portions of the coast line, the bearings of the following divisions may be thus listed:

LOCALITIES.	BEARING OF MEAN LINE.	DISTANCE IN GEOGRAPHICAL MILES.
Cape Mendocino to Punta Gorda . . . . .	N. 12° W.	14
Punta Gorda to Shelter Cove . . . . .	N. 40° W.	25
Shelter Cove to Point Arena . . . . .	N. 10° W.	64
Point Arena to Golden Gate, thru Tomales Bay.	N. 40* W.	90
Golden Gate to Pigeon Point » . . . . .	N. 15° W.	40
Pigeon Point toward Santa Cruz . . . . .	N. 40° W.	21
Point Pinos to Point Sur . . . . .	N. 13° W.	19
Point Sur to Port Hartford . . . . .	N. 37° W.	89
Port Hartford to Point Conception . . . . .	N. 6° W.	44

Now it is difficult to regard any considerable portion of the abrupt coastal slope of California between Cape Mendocino and Point Conception as other than a more or less degraded fault-scarp. If this view be accepted, it is clear that the trend of the coast and its geomorphic profile have been determined by two systems of faults meeting or intersecting at an angle of about 26° on their strike. Making some allowance for cliff recession, the base of both systems of scarps must lie some little distance off shore and be buried by the notable embankment of littoral sediments which conceals the true profile of the submarine rock surface.

Of the two systems of faults thus recognized as controlling the trend of the coast, one, viz. that which bears N. 37° W. to N. 40° W., conforms, as will be shown later, more or less closely with the prevailing structural lines, such as faults, folds, and belts of igneous rock found in the Coast Ranges; while the more meridional system is not a prominent feature of the Coast Ranges. It follows that since the mean trend of the California coast lies between the bearings of the two fault systems, the tectonic lines of the Coast System, if followed northwesterly, eventually emerge upon the coast. This obliquity of the

tectonic lines of the Coast System to the general trend of the coast has long been familiar to California geologists and has been particularly noted by Fairbanks,<sup>1</sup> but the probable explanation of it has not heretofore been set forth.

The coastal scarp is interrupted at a number of points and in a variety of ways. The most notable and interesting interruption is that of the Bay of Monterey. This is not only an embayment of the coast, but is a depression in the Coast Ranges extending down over their submarine portion to the 12,000-foot contour below sea-level. It brings the 3,000-foot submarine contour well inside the general line of the coast. This submarine valley has been regarded by some writers as a submerged valley of subaerial erosion, but there is little warrant for this view and much that conflicts with it. The valley of the Bay of Monterey, subaerial and submarine, is a synclinal trough the axis of which is approximately normal to the trend of the coast and of the Coast Ranges as a belt. In the axis of the syncline, and probably parallel to it, is a fault seen in the canyon between Pajaro and Chittenderi, which brings down the Tertiary rocks on the north side against the pre-Cretaceous granitic rocks of the Gavilan Range. Another interruption of the continuity of the coastal scarp is at the Golden Gate. Here the Coast Ranges have been locally deprest and the land valleys which were formerly drained by a trunk stream, where the Golden Gate now is, have been flooded by the waters of the ocean. The axis of this depression is, however, not well known. A third, apparent rather than real, interruption of the coastal scarp occurs at the place where the Point Reyes Peninsula projects out beyond the general line of the coast. Inside of the peninsula, however, there is a long narrow valley, the northern end of which is occupied by Tomales Bay and the southern end by Bolinas Lagoon, which separates it from the mainland proper; and to the east of this valley the coastal scarp rises with exceptional boldness.

The coastal scarp has had its profile modified in many places by wave-cut terraces formed during the uplift of the coast by stages in Pleistocene time, as previously stated. The relation of the coastal scarp to deformed basins of Merced (late Pliocene) strata indicate that it originated, in its essential features, at the period of orogenic activity which brought the Tertiary to a close. South of Point Conception the twofold system of faults which determines the configuration of the coast gives out and we enter upon a region of probably more complicated structure. The Santa Barbara channel appears to lie in a geosynclinal trough between the Santa Ynez range and the island chain from Anacapa to San Miguel. On the northeast side of San Clemente is a sharply defined fault-scarp, indicating that the island is a portion of an uplifted and tilted orographic block. The fault along which the scarp has been formed probably extends as far as the east side of Santa Barbara Island. San Clemente Island presents a magnificent series of wave-cut terraces up to an elevation of 1,500 feet. San Pedro Head is similarly uplifted and terraced, while the intervening island, Santa Catalina, shows no evidence of corresponding uplift, but has on the contrary been deprest. On the whole, the channel island platform between the edge of the subcontinental shelf and the coast presents the characters of a sunken mountainous tract, the inequalities of the surface of which are partly due to acute deformation and partly to erosional sculpture when the region was above sea-level. A more detailed interpretation of the structure of this region is rendered difficult by the absence of adequate soundings of the sea-bottom.

*Granitic Rocks.* •—Coming now to the consideration of the more important structural features of the Coast System, in the territory between the coast and its eastern margin, it must be stated that even here our information is very scant. One of the most important features of the Coast System from a structural point of view is the occurrence of a belt of granitic rock having a very notable linear extent thruout the ranges. This granite, as has been already stated, appears, in the vicinity of Tejon Pass, both from

<sup>1</sup> Am. Geologist, Vol. xi, Feb. 1893, p. 70.

its character and from the continuity of its exposure, to be identical with the granite of the Sierra Nevada. To the south of the Mojave Desert, it is very extensively and boldly exposed in the San Gabriel and San Bernardino Ranges and in other portions of the Coast System, as far south as the Mexican boundary. It also has broad exposures in the comparatively low-lying desert floors of Southern California, as shown by Hershey,<sup>1</sup> and in the Perris plain.

To the northwest of Tejon Pass, this granite appears in a series of linearly disposed areas extending thru the ranges. It forms a notable feature of the Santa Lucia Range on the west of the Salinas Valley, and also of the Gavilan Range to the east of the same valley. The granite of the Santa Lucia Range runs out to sea at Point Pinos near Monterey, while that of the Gavilan Range extends into Santa Cruz County and appears on the coast at Point San Pedro, a few miles south of San Francisco. Farther north it is seen in the Farallon Islands, the Point Reyes Peninsula, and on Bodega Head. The Santa Lucia and the Gavilan thus expose two quite distinct lines of granitic outcrop, practically parallel, and both crossing the general trend of the Coast Ranges obliquely and reaching the coast. Indeed, the easterly limit of all the granite of the Coast Ranges crosses the entire breadth of the latter obliquely between the Tejon Pass and Bodega Head. This signifies, of course, that whatever manifestations of crustal deformation elevated these belts of granite, the lines or axes of such deformation were not coincident in direction with the mean trend of the Coast Ranges, or with the mean trend of either of the margins of the Coast Ranges. It is noteworthy, too, that all of the Coast Range granite as far south as the vicinity of Tejon Pass lies to the southwest of the Rift along which the movement occurred which generated the earthquake of April 18, 1906. It is further noteworthy that near the northern end of the granite belt at Tomales Bay and Bodega Head, the Rift actually follows the line of contact between the granite on the west and the sedimentary rocks which are faulted against it. These facts suggest that very probably the Rift is similarly situated in the more southern Coast Ranges with reference to a deeper-seated contact between granite and sedimentaries; in other words, that the eastern edge of the Coast Range batholith, whether that edge be an original feature of the batholith or a feature determined by faulting, is with some degree of probability the line which determines in part the course of the modern Rift. Southward from the vicinity of Tejon Pass, however, the Rift passes into the granitic terrane.

*Folds.* — The pre-Knoxville folds of the Coast Ranges are little known, owing partly to the burial of the Franciscan rocks by later deposits, and partly to the complexity of the structures where the rocks are exposed and the difficulty of discriminating the effects of the earlier and the later movements; but chiefly owing to the absence of adequate topographic maps, so necessary for such studies. The conspicuous folds of the Coast Ranges are those which have been impressed upon the Tertiary and older strata together. These are usually rather sharp and more or less symmetrical synclines and anticlines, involving usually many thousands of feet of strata. In some cases these are asymmetric and even overturned, as in the Mount Diablo region, but they are never so closely appressed as to induce general and important deformation of the internal structure of the rocks affected. The folding has been effected without flowage, except perhaps locally where soft clays or shales were involved, and there has been no development of slaty cleavage or schistosity. In general the axes of the folds have a northwest-southeast trend, but there are numerous deviations from this rule and the axes of the minor folds are usually more or less divergent, as is of course generally true. There is, however, a pronounced parallelism in the dominant synclines and anticlines, the axes of which extend for many miles. Several of these are more or less oblique to the mean trend of the Coast Range belt, and thus appear to be truncated on the coast line, or on the eastern margin of

---

<sup>1</sup> Bull. Dept. Geol. Univ. Cal., vol. 3, No. 1.

the ranges. The coincidence of many of the larger valleys with a synclinal axis is very marked.

*Faults.* — In the Coast Ranges there are numerous faults, but our knowledge of them is limited, owing to the small amount of geological mapping which has been done in the region. With the extension of cartographic work, many more than are now known will doubtless come to light. Of those at present known, the great majority have a general northwest-southeast strike, but there are several minor faults which trend transverse to the general strike. The faults of the Coast Ranges, as well as those of other parts of California, are indicated, as to position and extent, on Map No. 1. A summary reference to them is all that will be here attempted.

The most northerly fault of the Coast Ranges is one which Mr. O. H. Hershey calls Redwood Mountain fault. It is an overthrust, according to Mr. Hershey, heading to the northeast and having a throw of probably over 5,000 feet. It trends southeast along the southwest flank of South Fork Mountain for scores of miles, and doubtless determines the very straight trend of this great ridge. Parallel to it, on the southwest side of Redwood Creek, near Acorn, there is another fault having a throw of at least 1,000 feet, according to Mr. Hershey. Its extent is unknown. The precipitous southwest front of Mount St. Helena has been shown by Osmond\* to be a degraded fault-scarp; and the downthrow on the southwest side of the fault is estimated by him to be not less than 2,500 feet. The western edge of the Sacramento Valley, from Benicia to Cordelia, is probably determined by a fault with an easterly downthrow.

In the Mount Diablo region, there is a pronounced overthrust fold which causes Miocene strata to rest upon Pliocene strata with a dip of 30° to 45° to the northeast. Louderback's work on the structure of Mount Diablo has shown that this over-tipt fold passes into a thrust fault whereby a considerable proportion of the mountain has been shoved to the southwest.<sup>2</sup> The west side of San Ramon and Livermore Valleys is bounded for the most part by a steep mountain wall at the base of which, near Pleasanton, the Tertiary rocks are faulted down against the Franciscan. This fault extends southward thru Calaveras Valley and past Mount Hamilton. Its general course is about N. 35° W. It has an extent of at least 60 miles and may be very much longer. In the Berkeley Hills to the east of this there are many minor faults, both overthrust and normal, which will not be described in detail. In the Mount Hamilton Range, between the crest and the Santa Clara Valley, there are several faults, notably the Mission Creek, Mission Peak, Mount Hamilton, and Master's Hill faults, which have a more or less regular northwest-southeast trend; and there are several shorter faults transverse to these, and of variable strike.

The valley of the Bay of San Francisco and its prolongation southward in the Santa Clara Valley is bounded on the northeast side by a range of hills which presents a very even, straight, and on the whole, but little undulated, front to the southwest. This even front extends from near Point Pinole, on San Pablo Bay, to the vicinity of Hollister, a distance of about 100 miles, forming a very striking geomorphic feature of the Coast Ranges. At Berkeley and Oakland, and southeast of the latter, there is evidence that this even front represents a somewhat degraded fault-scarp, or series of scarps, and this interpretation may with very probable truth be placed upon it for its entire extent. Near Berkeley the slope of this degraded scarp is traversed by supplementary step faults, which are not improbably characteristic of it in other places; so that in regarding the feature as a fault-scarp it is not intended to apply that term too narrowly, but to include rather the idea of a zone of acute deformation traversed by step faults. This line has a course of about N. 35° W. North of San Pablo Bay, on the geographic prolongation of the line, a similar feature, though by no means so straight, is found on the east side of the

<sup>1</sup> Hull. Dept. Geol., Univ. Cal., vol. 4, No. 3, p. 78.

\* Results not yet published.

Santa Rosa and Russian River Valleys up to about Cloverdale. Here, however, evidence of faulting is lacking, altho it is known in places to be a line of flexure. Along the base of this line of scarp, between Oakland and San Jose, occurred the fault which caused the earthquake of 1868. It may be referred to as the Haywards fault, from the fact that it passes thru that town.

An interesting and important fault traverses the peninsula of San Francisco, a little south of the city. The course of this fault can not be precisely determined, as its trace at the surface is obscured by Pleistocene and recent deposits. Its approximate position is at the southwest base of San Bruno Mountain, with a strike of about N. 43° W. By this fault the Merced strata, which are well exposed on the sea-cliffs south of Lake Merced to the thickness of over a mile, are dropt down against the Franciscan rocks, the throw being estimated at not less than 7,000 feet. To the northeast of the main fault, and close to the face of the mountain, is an auxiliary fault, and between these two faults there is a block of the Franciscan which has dropt only to a limited extent, and which is of the same character as the kernbutts of the Kern River.<sup>1</sup> The bold and precipitous southwest face of San Bruno Mountain is thus a fault-scarp with two facets, one for the main fault and the other for the auxiliary, both being well exprest in the geomorphic profile of the mountain. This fault-scarp appears to be the southern prolongation of the scarp which forms the coastal steep slope to the north of the Golden Gate, and seems to converge upon the San Andreas fault, off the Golden Gate, making a very acute angle with it. It affords an excellent illustration of the general fact above alluded to, that the northwesterly members of the fault system controlling the configuration of the coast are prolongations of fault-lines within the Coast Ranges. Knowledge of the extent of this fault, altho its throw is so notable, is limited to the peninsula of San Francisco.

Outside of Fort Point, at the Golden Gate, and a little south of the point, is a very well exposed fault which appears to strike southeast across the city of San Francisco. The fault is nearly vertical and has a throw of at least some hundreds of feet, whereby the serpentine on the north has beer dropt against a formation of radiolarian cherts.

The most interesting fault traversing the Peninsula of San Francisco is the San Andreas fault, on which movement was renewed on April 18, 1906, causing the earthquake. The extent and course of this fault are described in detail elsewhere. To the southwest of the San Andreas fault, on the Peninsula of San Francisco, and in the Santa Cruz Mountains, are several other faults of notable extent. Of these may be mentioned the Fifield, Pilarcitos, Castle Ridge, Butano, Boulder Creek, and San Gregorio faults, all of which are important features of the structure of the region.

On the southwest side of Montara Mountain is a very precipitous seaward slope, at the base of which strata of Miocene age are tilted at rather abrupt angles against the granite. The strata of arkose sandstone at the base still rest against the original floor of deposition, but it is difficult to see how such an acute uplift could take place in a granite *massif* without deformation of the granite. Such deformation might take the form of plastic flow if it were sufficiently deep-seated, or it might find its expression, in a zone of faults; and as there is no evidence of plastic deformation, it is concluded that the uplift of Montara Mountain was effected by faulting within the granite, the same deformation appearing as flexure in the stratified rocks which flank the mountain on this side.

Northeast of the San Andreas fault are the Belmont and Black Mountain faults, the latter a branch from the San Andreas fault. In the gap between the Santa Cruz and Gavilan Ranges is a fault followed by the canyon of Pajaro River near Chittenden, which drops the Tertiary formations on the north against the pre-Franciscan granitic rocks of

---

<sup>1</sup>Bull. Bept. Geol., Univ. CaL, vol. 3, No. IS.

the Gavilan Range on the south. This fault is interesting for several reasons: it lies approximately in the axis of the geosyncline of the Bay of Monterey; it is transverse to the San Andreas Rift and intersects it; and it is near the place where the surface rupture of the San Andreas fault ceased on April 18, 1906.

South of the Bay of Monterey, one of the dominant structural lines of the Coast Ranges is the Santa Lucia fault, at the base of the Santa Lucia Range on the border of Salinas Valley. It is traceable from the vicinity of Bradley to the Bay of Monterey and it is probably the chief factor in determining the course of the Salinas-Valley and the steep easterly front of the Santa Lucia Range. Near its southern end, the Santa Lucia fault is paralleled on the southwest by another fault which probably determined to some extent the course of the valley of San Antonio River. Farther south a fault parallels the last two, between Dove and Templeton; and to the southwest of this lies the much longer fault which passes close to San Luis Obispo, extending from near San Simeon to the drainage of the Santa Ynez.

The northeastern flank of the San Emidio Range, at the southern end of the great valley, is with little question a fault-scarp. The same may be said of the north flank of the Santa Ynez Range and the south flank of the Santa Monica Range. The San Gabriel fault, which bounds the range of that name on the south, branches from the San Andreas fault near San Bernardino and follows the base of the range with an east-west trend. Beyond Pasadena it bends slightly to the north and extends thru to the coast in the vicinity of Carpenteria. Near Pasadena a branch fault leaves it, with a northwesterly strike, on the northeast side of the Verdugo Mountains. Southeast of Los Angeles, the most notable faults are the San Jacinto and Elsinore faults, both of which have very pronounced scarps. There are, however, several others. All the faults in this region have a northwest-southeast strike, and are thus in contrast to the system of faults extending from Point Conception to the Colorado Desert along the Sierra Madre, in which the dominant trend is east and west.

The foregoing summary enumeration of the more important faults at present known in the Coast System of mountains makes it clear that the San Andreas fault, upon which movement took place on April 18, 1906, is not a singular or unique feature of the structure of these mountains. It is only one of many faults, on all of which in time past there have occurred many differential movements, each productive of an earthquake. Map No. 1, upon which the above faults are represented, indicates other faults in California, Nevada and Oregon at present known to geologists.<sup>1</sup> Perhaps the most interesting of these, from the present point of view, is the fault at the eastern base of the Sierra Nevada, upon a portion of which the movement took place that caused the earthquake of 1872. The map may be regarded as a preliminary attempt to bring together, in cartographic form, our knowledge of the position of faults in this region. A full discussion of these features, with references to the literature bearing upon them, would be out of place here, altho their occurrence suggests seismic possibilities.

#### GEOMORPHIC FEATURES.

Certain of the geomorphic features of the Coast Ranges, particularly as regards their margins, have necessarily been alluded to in the discussion of the structure. It is proposed here to describe quite briefly the salient characters of the relief, in their relation to the structure.

The Coast Ranges in general, between the coast and the Great Valley and north of Santa Barbara Channel, comprize a series of ridges and intervening valleys of mature aspect.

<sup>1</sup> In compiling the data for the representation of the faults of California, free use has been made of information kindly supplied by Messrs. H. W. Turner, W. Lindgren, W. C. Mendcnhall, H. W. Fairbanks, J. S. Diller, P. M. Anderson, It. Arnold, J. C. Branner, G. D. Louderbaek, and O. H. Herahey.

The ridges exhibit for the most part a pronounced parallelism in a direction more or less oblique to the mean trend of the coast and of the Coast Ranges as a belt. The highest of these ridges rarely exceed 5,000 feet in altitude and their crests usually range between 2,000 and 4,000 feet above sea-level. Rarely the tops of the ridges are more or less flat, presenting the character of a rolling upland, the rule being that the crests are determined by the intersection of the valley slopes on either side. In the northern Coast Ranges, however, it is generally true that the ridge crests over wide areas reach about the same altitude and give the observer the impression of a dissected upland of fairly uniform and gentle slope. The valleys in which the streams flow are usually wide-bottomed in the softer formations and narrow in the harder rocks. In such portions of the region as have been geologically examined, it appears clear that the courses of these streams are closely, tho of course not wholly, controlled by the strike of the rocks or the strike of faults. The general scheme of drainage is that which might be termed subsequent, the streams having adjusted themselves to the structural lines, and having been greatly extended by headwater erosion along those lines at the expense of original consequent streams, traversing the region transversely to the trend of the structure to the sea on the one side, and to the Great Valley on the other. This interpretation is rendered more plausible by the fact that, in a general way, the broad structure of the Coast Ranges appears to be that of a geanticline, with various subordinate folds, the dissection of which by erosion reveals the Franciscan rocks in the central portion of the ranges, flanked on either side by rocks of later age. This interpretation appears to be quite acceptable for the Eel River and its various branches, which constitute the chief drainage of the northern end of the region. This drainage has all the characters of a subsequent system, and is in harmony with the mature aspect of the ridges and valley slopes. All the numerous tributaries of the river flow in longitudinal valleys, parallel or subparallel to one another, and connected by short transverse streams cutting thru the intervening ridges; and the course of the longitudinal valleys is that of the strike of the rocks, being, like the latter, oblique to general trend of the Coast Range belt. Thruout this region, within the hydrographic basin of the Eel River, there are below the crests of the ridges numerous instances of high valleys and broad, more or less obscure terraces, representing an inheritance from earlier stages of the geomorphic evolution of the region, when it stood at lower levels than at present. These have been described<sup>1</sup> in a valuable paper by Diller.<sup>1</sup>

between the headwaters of Eel River and the Bay of San Francisco the interpretation of the drainage as subsequent is not so certain, altho here the general geomorphic profile is even more mature than it is on the north, a fact referable to the softer character of certain geological formations which prevail. Here we have, as before, a system of stream valleys, notably Russian River Valley, Sonoma Valley, Napa Valley, and Berryessa, and Clear Lake Valleys, which are clearly evolved by stream erosion under the control of structure. The transverse connecting link from one longitudinal valley to another, which is so characteristic of subsequent drainage, is not apparent on the maps, but its absence may be more apparent than real. The lower stretch of Russian River, from Healdsburg to the sea, has the appearance of a transverse stream tapping a longitudinal valley of very mature character, and may be the remnant of an original consequent stream. This view, however, is open to the objection that the lower stretch of Russian River near the sea has a more youthful aspect than might reasonably be expected under the hypothesis. On account of the rather immature character of the transverse outlet of Russian River, it has been suggested that it is of later date than Russian River and represents a small stream which has cut its way back from the coast and captured the waters of the river, which formerly went to the Bay of San Francisco, the capture being

<sup>1</sup> U.S. Geol. Surv. Bulletin, 196.



facilitated by the deformation of the region. The offsetting consideration to this objection, based on the less mature aspect of this part of the valley, is that it traverses much harder rocks than are found in the wider valley above. In a word, the view that the lower transverse stretch of Russian River may be the remnant of an original consequent stream, from which, by subsequent development, has been evolved the longitudinal Russian River Valley, has not yet been satisfactorily negated.

Somewhat similar features occur on the east side of the Coast Ranges. Cache Creek and Putah Creek, draining longitudinal valleys within the Coast Ranges, both emerge upon the Great Valley thru transverse gorges in the Blue Ridge, the most easterly of the Coast Ranges. These transverse gorges can scarcely be regarded as other than consequent trunks crossing a hard barrier within which, in softer formations, longitudinal or subsequent valleys have been evolved. The apparent absence of the transverse connecting links between Napa, Sonoma, and Petaluma Valleys is explained when it is recalled that while the streams draining these valleys flow directly to salt water, they nevertheless flow to a drowned valley. The trunk stream trench from which Petaluma, Sonoma, and Napa Creeks are subsequent branches lies below the waters of San Pablo Bay. In general, Santa Rosa Valley (lower part of Russian River Valley), Petaluma Valley, Sonoma Valley, and Napa Valley have been evolved by erosion along synclinal axes. This fact also tends to weaken their interpretation as due to subsequent development by headwater erosion; since, if the synclinal folds were expressed as troughs at the surface at the time of the folding, then the drainage would have been both consequent and parallel to the structure.

Coming farther south, the valley of the Bay of San Francisco and its extension in the Santa Clara Valley is a large feature in which deformation and erosion have probably played equal rôles. Its trend is strictly determined by the Hayward fault line previously described. Southward from Hollister, the valley loses its breadth and passes into the much more constricted valley of the San Benito River, draining the Coast Ranges to the east of the Gavilan Range. The Bay itself and its inland extensions afford a magnificent illustration of a drowned valley-land due to subsidence of the valley-bottoms below sea-level.

Livermore Valley, a few miles to the east of the Bay of San Francisco and separated from it by the ridge of the Berkeley Hills, is a very noteworthy feature. It is a broadly expansive alluviated valley, bounded on the west by the degraded fault-scarp which limits the Berkeley Hills to the east; on the east by the slopes of Mount Diablo; and on the south by the slopes of Mount Hamilton. On the north it is open by way of the wide and low San Ramon Valley to Suisun Bay, and the northern portion of the valley drains this way. The greater part of the waters which come to it from Mount Diablo and from Mount Hamilton, however, are carried off by Alameda Creek thru Niles Canyon, a narrow gorge which transects the bold ridge separating it from the Bay of San Francisco. Alameda Creek has a hydrographic basin of 600 square miles, and it is a remarkable fact that it finds its outlet across the strike of the range thru a bold ridge, instead of following the wide open valley leading directly to Suisun Bay with no barrier in its path. It is a fair inference that Livermore Valley is structural rather than erosional in its origin and that, anterior to the acute deformation of the region, the drainage was consequent in the path followed by Niles Canyon. The deformation involved the uplift of the Berkeley Hills and the complementary depression of the Livermore Valley tract, and this deformation proceeded at a rate which was sufficiently slow to permit the stream, by downward corrosion across the rising mass, to maintain its course. Alameda Creek in Niles Canyon is thus a remnant of the consequent drainage of the region and is antecedent to the uplift which gave rise to the Berkeley Hills.

In the Coast Ranges between the Bay of Monterey and the Santa Barbara Channel, the chief valleys are those of Salinas River and its tributary, the San Juan; the Carissa Valley, and the valleys of the Cuyama and Santa Ynez Rivers. Of these the Salinas Valley is the largest. It is a wide, terraced valley cut by the river out of rather soft Tertiary and later deposits, which appear to have been in part let down against the older rocks of the Santa Lucia Range by the Santa Lucia fault. In its lower part it lies between the Gavilan and Santa Lucia Ranges, and the trend thus established is maintained by the main stream as far as San Miguel. Beyond that the same general trend is continued up its tributary, the San Juan, and thence thru the Carissa Plains to a point close to the southern end of the Great Valley. The eastern side of the upper end of the valley, particularly the eastern side of the Carissa Plains, follows closely the line of the modern earthquake rift to be presently described; and there can be little doubt, not only that in so far as the valley is an erosional feature its erosion has been controlled by structural features, but also that deformational processes have had a considerable share in its evolution. The axis of the valley thus indicated is singularly straight and has a length of about 175 miles. Its upper part, the Carissa Plains, is an arid plain without drainage and contains a very saline lake. This plain is a surface of alluviation. The lower end of the valley opens widely on the Bay of Monterey and the fine stream terraces which flank its sides afford an excellent record of the recent uplift of the region.

The valley affords another striking illustration of the obliquity of the geomorphic as well as the structural features to the general trend of the Coast Range belt, and their constant tendency to emerge upon the coast. From the eastern margin of the valley at the south end of the Carissa Plains, one can look down upon the Great Valley, near Sunset, a few miles distant; and only a narrow ridge separates the two valleys, altho they differ greatly in altitude. From this point in its course of 175 miles, Salinas Valley crosses the entire width of the Coast Ranges. South of San Miguel, the Salinas River proper lies in a less open valley with north and south trend as far as Templeton, a distance of about 15 miles, and then opens out into a wider valley having a northwest-southeast trend for about 35 miles to the headwaters of the stream. Several of the minor tributaries of the Salinas show a marked tendency to the development of subsequent valleys. On the east side of the river, this is particularly marked on San Lorenzo Creek in Priest Valley, and on Chalome Creek in Chalome Valley. These comparatively large valleys may be referable in part, however, to deformation, inasmuch as they are on the line of the Rift. Their geomorphic history has not yet been studied. On the west side of Salinas Valley the two chief tributaries, the San Antonio and the Nacimiento, have developed well-defined subsequent valleys in the heart of the Santa Lucia Range.

In the valley of the Cuyama or Santa Maria River, the effect of a twofold structural control is apparent. The upper reaches of the river flow thru a broad valley with an alluviated bottom on the northeast side of the San Rafael Range. The general trend of the river in this part of its course is northwest-southeast, and it is separated from the Carissa Plains by a high mountain ridge with a very precipitous southwest front, which probably represents a fault-scarp. Below this expansive high valley, the stream enters a rather narrow canyon and shortly after this bends at right angles and flows southwest toward the coast, entering eventually on the broad Santa Maria Valley which is open to the sea. The contrast in the geomorphic character of the upper and lower reaches of the river, the greater age of the former, and the sudden change in the course of the stream where the two types of geomorphy meet, suggests that the high valley of the upper reaches was once connected with the Salinas drainage and that it has been captured from the latter, in comparatively recent time, by a stream cutting back from the coast at the northwest end of the San Rafael Range.

In the valley of the Santa Ynez, there is a marked departure from the northwest-southeast trend which characterizes the geomorphic features of the Coast Ranges in general, and a more striking instance than any yet cited of the obliquity of those features to the general trend of the Coast Range belt. The valley lies nearly east and west and its general slope is southward to the base of the precipitous northern face of the Santa Ynez Range. This face is, as has been indicated, a fault-scarp; and the course of the valley is thus seen to be in intimate relation to this dominant structural feature. To the west the valley opens widely to the sea, while to the east it loses its individuality in the headwater canyons of eastern Santa Barbara County and western Ventura County.

Between the Santa Ynez Valley and the upper Cuyama is the rugged and deeply dissected country culminating in the San Rafael Mountains on the northern side of the tract. This mountainous belt has a trend intermediate between the pronounced east-west trend of the Santa Ynez Range and the northwest-southeast trend of the Coast Range ridges and valleys to the north. For a portion of its length the belt is bounded on the south by the Santa Clara Valley, with a general east and west course; but across the headwaters of Santa Clara River the mountainous tract persists and finds its prolongation, with the same general trend, in the San Gabriel Range, and beyond Cajon Pass in the San Bernardino Range, both bold and lofty sierra. It may even be considered as extending, under the name of the Chocolate Mountains, to the Colorado River above Yuma. From Tejon Pass southeast to Cajon Pass, the northern side of this mountain tract presents a very abrupt front with a very straight course. At the base of the abrupt slope lies the San Andreas Rift. To the north of this, and between it and the southeast scarp of the southern Sierra Nevada, lies the Mojave Desert. To the south of the southeast end of the San Bernardino Range and west of the Chocolate Mountains lies the Colorado Desert. As has been already indicated, the south side of the San Gabriel Range is determined by a profound fault. Lying thus between two faults, the range is a magnificent example of a horst which has been thrust up between its bounding faults. It is the convergence of these two bounding faults which segregates the San Gabriel Range from the San Bernardino Range in the vicinity of Cajon Pass. The latter range is similarly bounded on the south by the same fault as that which determines the south front of the San Gabriel Range, but here it is coincident with the Rift. Between Los Angeles and Ventura lie the short ranges known as the Santa Monica and the Santa Susannah Mountains, inclosing San Fernando Valley. The Santa Monica Range is probably on the same line of orogenic uplift which finds its expression farther west in the Santa Cruz and Santa Rosa Islands.

South of the San Gabriel Range lies the fruitful valley of southern California, extending with an east-west course from the sea to San Bernardino. South of this valley, and between the Colorado Desert and a somewhat elevated coastal plain bordering the Pacific, is a mountainous tract, the ridges of which swing around into a more northwest-southeast trend, and so conform again with the prevailing trend of the ridges and valleys of the Coast Ranges north of the San Rafael Mountains. The valleys in this region are, however, less regular in their orientation than those of the northerly Coast Ranges, and the geomorphic features are less mature, if we except certain very old features which have survived from an earlier cycle of geomorphic evolution. The consequent character of the streams on the seaward slope is much more pronounced than in any part of the northern Coast Ranges, and on the whole the geomorphology of the region must be regarded as less advanced than to the northward, and more closely allied in its morphogeny with the Sierra Nevada than with that of the Coast Ranges of northern California.

The notable ranges of this region are the Santa Ana Mountains and the San Jacinto Mountains. The former present the features of a seaward sloping, tilted, orographic

block, with a very straight and abrupt fault-scarp facing the northeast and overlooking the Perris Plain. This is an elevated, and as yet little dissected, peneplain with remnants of Tertiary or later deposits resting upon it, indicating that it has, in part at least, but recently been resurrected from a buried condition. In San Diego County the Santa Ana Mountains find their prolongation in a less regular and broader group of ridges, but doubtless the same tilted block structure prevails to the international boundary and beyond, since the northeast scarp appears to persist in the same general trend, and the same type of consequent drainage characterizes the seaward slope. Still east of the line of the scarp in southern San Diego County, there is another orographic block, bounded on the east by a very recent and very precipitous scarp looking out over the desert.<sup>1</sup> To the northwest the range becomes subdued in the Puente Hills, where a broad anticlinal structure replaces in part the deformation by faulting. In two notable instances, and perhaps in others, the seaward streams of the Santa Ana Mountains cut entirely thru the range and drain the valley-land beyond its northeasterly scarp. These are the Santa Ana and the Santa Margarita Rivers. They are both probably antecedent to the more acute phases of the tilting, of the region and have persisted in their course during the development of the fault-scarp.

The San Jacinto Mountains form an important feature of the region as a bold ridge with northwest-southeast trend lying between Perris Plain and the northern end of the Colorado Desert. Both sides of the range are precipitous and are probably determined by faults. On the southwest side there were notable ruptures of the ground in the earthquake of 1898, indicating that the fault on that side is still in active development.

---

<sup>1</sup> Verbal communication from Dr. H. W. Fairbanks.

## THE SAN ANDREAS EIFT AS A GEOIOEPHIC FEATURE.

### GENERAL.

Extending thru the greater part of the Coast System of mountains from Humboldt County to the Colorado Desert, a distance of over 600 miles, is a line or narrow zone characterized by peculiar geomorphic features, referable either directly to the modern deformation of the surface of the ground or to erosion controlled by the lines upon which such deformation has taken place. This peculiar feature has been known, both to Californian geologists and to residents of the sections where its characters are most prominent, but its extent and importance were not fully appreciated until after the earthquake of April 18, 1906. It is commonly reported among the residents of the southern interior Coast Ranges, particularly in San Benito, Monterey, and San Luis Obispo Counties, that displacement of the ground occurred on this line in the earthquake of 1857 and in certain later earthquakes. The first reference in scientific literature to this feature appears to have been in the year 1893, in a paper entitled "The Post-Pliocene Diastrophism of the Coast of Southern California," by Andrew C. Lawson, which is quoted in the sequel. The next reference to this peculiar line is in the eighteenth annual report of the U. S. Geological Survey for 1896-1897, Part IV, in a paper by Schuyler on "Reservoirs for Irrigation," where, pp. 711-713, the significance of the line is fully recognized in the following words quoted in full:

This reservoir has especial interest, not only as the first one of any magnitude completed on the Mojave Desert or Antelope Valley side of the Sierra Madre in southern California, but because it lies directly in the line of what is known as "the great earthquake crack" of this region, which is marked by a series of similar basins behind a distinct ridge that appears to have been the result of the great seismic disturbance.

This remarkable line of fracture can be traced for nearly 200 miles thru San Bernardino, Los Angeles, Kern, and San Luis Obispo Counties, and deviates but slightly here and there from a direct course of about N. 60° to 65° W. There appears to have been a distinct "fault" along the line, the portion lying south of the line having sunken and that to the north of it being raised in a well-defined ridge. In many places along the great crack, ponds and springs make their appearance, and water can be had in wells at little depth anywhere on the south side of the ridge before mentioned. A tough, plastic, blue clay distinguishes the line of the break, in this portion of its course at least; and where the line crosses Little Rock Creek, the blue clay has formed a submerged dam, which has forced the underflow near the surface and created a "cienega" immediately above it. After crossing the line, the water of the creek drops quickly away into the deep gravel and sand of the wash. The same effect is noticeable at other streams, and it has been suggested as the probable cause of the very distinct rim marking the lower margin of the San Bernardino Valley artesian basin and confining its waters within well-defined limits, as this rim is nearly on a prolongation of the line that is traceable on the north side of the mountains —\* the break having crost the mountains thru the Cajon Pass on the line of Swartout Canyon.

In 1899 the essential features of the same line in the region north of the Golden Gate were recognized and discust by F. M. Anderson.<sup>1</sup> In later years Dr. H. W. Fairbanks has traced out the line in various field trips and has given several public lectures descriptive of its features and its significance, but has published no systematic account of his studies.

The fact that the earthquake of April 18, 1906, was caused by a rupture and displacement of the earth's crust along this line for a distance of about 190 miles, immediately focussed the attention of local geologists upon it. Among those engaged upon

---

<sup>1</sup> The Geology of the Point Reyes Peninsula, Bull. Dept. CJeol., Univ. Cal., vol. 2, No. 5, p. 143 *ei Seq.* Anderson, however, supposed, as is indicated by the last paragraph of his paper, that the faulting antedates entirely the Pleistoeene terrace formations.

its investigation, it became known as the "rift line." Since the earthquake it has been traced as a geomorphic or physiographic feature from Humboldt County to the Colorado Desert, with a possible gap between Shelter Cove and Point Arena, where, if continuous, it lies beneath the Pacific. Its continuity has, however, been satisfactorily established from Point Arena to Whitewater Canyon, at the northern end of the Colorado Desert, a distance of 530 miles. Thruout this entire distance it lies along depressions or at the base of steep slopes which are either the direct result of crustal displacement or of stream erosion, operating with exceptional facility along lines of displacement. There can be no doubt that the displacements have been recurrent thru a considerable part, if not the whole of Pleistocene time, and that in parts of its extent, at least, the movements have taken place on fault-lines which originated in pre-Miocene time. The later movements on this line have given rise to minor features which subaerial and stream erosion have not yet obliterated, and it is these minor features chiefly which have attracted attention to the Rift by reason of their striking contrast with more common geomorphic forms due to erosion. These minor features are chiefly low scarps and troughs bounded on one or both sides by low, abrupt ridges in which frequently lie ponds or swamps of quite small extent.

A summary account will now be given of this rift line as a geomorphic feature.

#### HUMBOLDT COUNTY.

The most northerly point in California at which geomorphic features directly referable to the violent rupture of the earth's crust have been observed are those noted by Mr. F. E. Matthes in the vicinity of Petrolia in Humboldt County. Here south of Petrolia, on high bare mountain spurs between Cooskie, Randall, and Spanish Creeks, he reports the occurrence of several small ponds and ridges such as have been familiar to those engaged in the field study of the earthquake phenomena as characteristic Rift features. Similar features are also found at the base of these spurs near the shore. These are in line with similar features found by the same observer between Telegraph Hill and Shelter Cove, a few miles to the southeast. Here, particularly in Wood Gulch (plate 1) is a narrow depression with ponds, ridges, and saddles, which appears to be essentially a feature due to deformation and to have determined the course of the drainage. The course of the depression is about  $F. 25^{\circ} W.$ ; In this depression lies the trace of the fault upon which movement took place on April 18, 1906. Its course, if followed southward to the cliffs above Shelter Cove (plates 2A, 3A, B), heads out to sea with a trend nearly parallel to the coast. Great landslides occur along the coast in proximity to this line, and are in part on the Rift. The rocks traversed by the Rift in this part of Humboldt County appear to consist wholly of shales, sandstones, and conglomerates which are probably of Cretaceous age, altho since the geology of the region has not been studied, positive statements in this regard can not be made. The region, is high and rugged, with a very precipitous descent to the sea, King Peak having an elevation of 4,090 feet at a distance of about 2 miles from the shore.

#### POINT ARENA TO FORT BOSS.

From Shelter Cove to near Point Arena, the Rift, if continuous, lies beneath the waters of the Pacific. The continuity for this stretch is of course open to question, and in another place the considerations bearing upon this point will be presented. At the mouth of Alder Creek, 4.5 miles northwest from Point Arena, the Rift enters the coast from the sea and is thence traceable continuously to a point about 2 miles southeast of Fort Ross, a distance of about 43 miles, with a nearly but not quite straight course, being slightly curved with the convexity toward the ocean. (See map No. 2.) For our knowledge



A. Wood Gulch, Humboldt County. The Eift near its northern end. A. S. E.



B. Another view of the Rift. Wood Gulch. A. S. E.

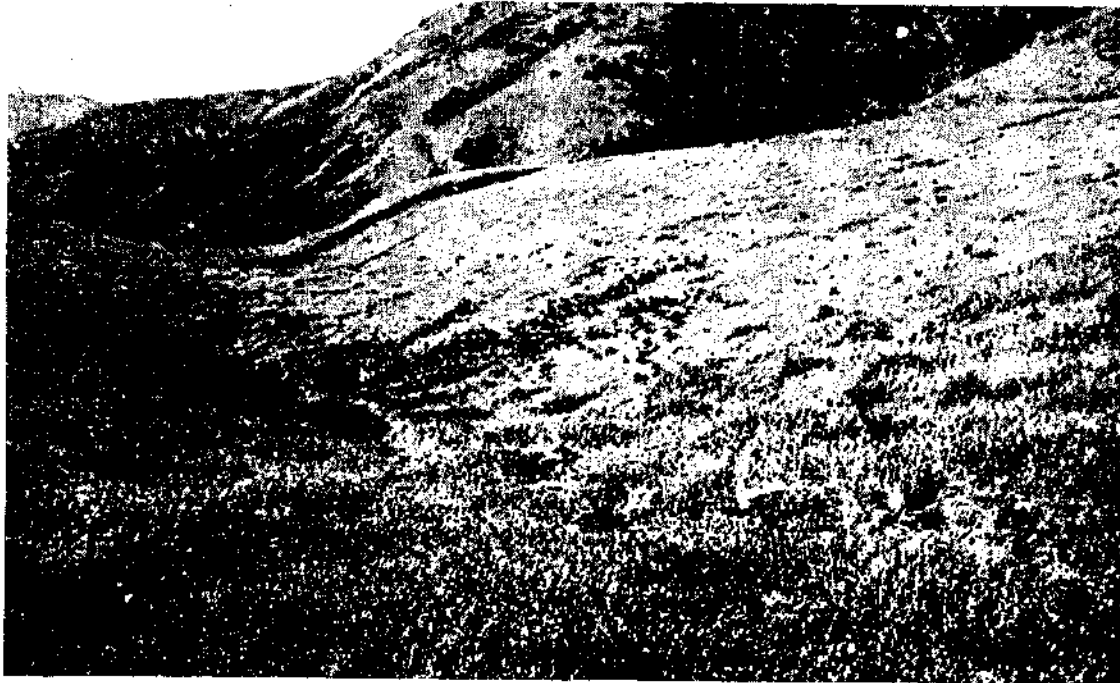

A. The Bift above Shelter Cove, Humboldt Comity. A, S. E.



B. The Eift on the divide between the upper Guaiala and the coast north of Port Rosa. H. W. F.





A. The Eift above Shelter Oove, looking northwest. The fault-line follows old diatrophic features. P.E.M.



B. Northeast of Shelter Oove. Eift in the middle ground. F. B. M.



C. Looking up Garcia Eiver along the Eift. F. E. M.



D. Looking up Garcia Eiver along the Eift. F. E. M.



A. Characteristic Rift features southeast of Fort Eosa. Figure on fault-trace, A, C. L.



B. Characteristic Eift features southeast of Fort Eosa. Fault trace in foreground. A. C. L.

of the features of the Rift for this part of its course, we are chiefly indebted to the observations of F. E. Matthes and H. W. Fairbanks. For this stretch, its course is somewhat more meridional than the trend of the coast, so that it converges steadily southward upon the shore line, and finally intersects it below Fort Ross. Between the mouth of Alder Creek and the Garcia River the Rift is marked across a low, rolling country by a series of depressions, swamps, and ponds, many of which are without outlet. At the point where it intersects the Garcia River, the valley of the latter from that point upstream for a distance of 9 miles follows the Rift (plate 3c, D), and its course has with little question been determined by the structural conditions inherent in the Rift. On the southwest side of the valley the minor features of low ridges and swamps are common, and there are in places two sets of parallel ridges. From the head of the longitudinal valley of the Garcia, the Rift passes over a sag in the mountains to the Little North Fork of the Gualala River. From this point southeast, the Rift follows the common and very straight valley of the Little North *Fork* and the South Fork of the Gualala. This valley is separated from the coast by a ridge varying in height from 300 to about 1,000 feet. The Rift follows the valley, or rather the valley follows the Rift, for a distance of about 18 miles, and is characterized by the usual abnormal features of low ridges, with elongated swamps and ponds between, extended parallel to the river. The ridges again evince a tendency to appear in pairs, which is peculiarly marked near Stewarts. North of Plantation House the Rift passes over a broad, swampy divide in the coastal ridge (plate 2B), and at the House is marked by two small ponds. South of the Plantation House is a series of swampy hollows extending toward Buttermore's ranch. The latter lies in a broad, swampy saddle. From Buttermore's ranch southeastward the Rift is marked by a line of deformation traversing the uplifted wave-cut terraces and sea-cliffs which are notable features of this part of the coast. Low ridges with northeasterly scarps form barriers which pond the surface waters and give rise to numerous ponds and small swamps or elongated hollows. Several small ravines and gulches lie in its course, and occasionally a landslide is clearly related to the path of the Rift. In the vicinity of Fort Ross, the geomorphic forms of the Rift are particularly well exemplified and a typical stretch of the latter is cartographically represented on map No. 3. Low ridges up to 10 feet in height, some with mature rounded slopes, others with abrupt slopes to the northeast, mark its course. Alined with these are scarps which, by reason of their monoclinical slopes, can scarcely be called ridges. Behind the ridges and scarps are pools and small swamps. Some of the small streams follow the Rift and have established notable ravines along its course. (Plates 4 and 5.)

With regard to the geology of the territory traversed by the Rift from the vicinity of Point Arena to Fort Ross, Dr. H. W. Fairbanks has kindly examined the ground and supplied the following note:

Except for a strip of sandstones (Walalla beds) of upper Cretaceous age extending along the coast north and south of the mouth of the Gualala River, and a triangular area of Monterey shale and sandstone underlying the coastal terraces in the vicinity of Point Arena, the rocks of almost the entire mountainous region between the upper Russian River Valley and the coast belong to the Franciscan. There seems to be but one fault in this region, and that is on the line followed by the Rift. The Walalla beds begin upon the coast a little south of Fort Ross and, extending inland, form the ridge between the Gualala River and the ocean. The formation thins out against the ridge bounding the Gualala Valley upon the northeast. The line of junction is an irregular one, for in places the soft sandstones reach quite to the top of the ridge referred to. These beds extend along the coast to the northwest for more than 30 miles, finally terminating 7 or 8 miles south of Point Arena, where they are overlain by the Monterey sandstones and shales. The Rift does not follow the contact between the Walalla and Franciscan formations and the vertical displacement does not appear to have been very great, as in only one place was it enough to bring up the underlying Franciscan rocks upon one of its walls. The Rift, for something more than a mile after emerging from the ocean southeast of Fort Ross, lies in the Franciscan formation, and the latter is greatly

crushed and broken along it. Back of Fort Ross, the surface rocks traversed by the Rift belong to the Walalla formation, and from this point for a number of miles to the northwest no other formation appears.

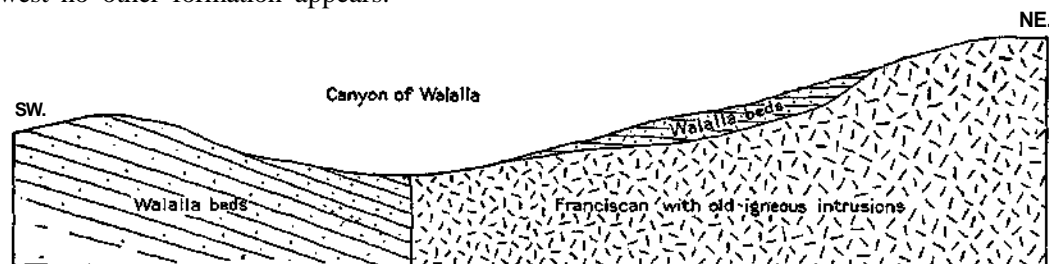

FIG. 1.—Geological section transverse to the Rift where it is followed by the Walalla (Gualala) River.

At the point where the road from Stewarts to Geyserville crosses the Gualala River, faulting and erosion have exposed the underlying Franciscan formation. This appears upon the northeast side, showing that the opposite side, that toward the ocean, has dropt. The Franciscan occupies but a narrow strip and is replaced for some distance up the ridge upon the northeast, by Walalla sandstones. These relations are shown in the cross-section sketch shown in fig. 1. Near the mouth of the Walalla River the formation upon the coast side of the Rift still appears to be the Walalla sandstones; the rocks upon the opposite side are buried under the alluvium of the valley. After leaving the valley of the Garcia River, the Rift lies wholly within the Franciscan formation until it disappears in the ocean. The Monterey shales with sandstones at their base form nearly the whole of the coastal terraced plain in the vicinity of Point Arena. They rest unconformably upon the Franciscan rocks and dip at a steep angle to the southwest. The Monterey formation nowhere appears to come in contact with the fault.

#### BODEGA HEAD TO BOLIFFAS BAY.

*General Note.* — From the point 2 miles south of Fort Ross where the Rift in its southeasterly course leaves the shore, it passes beneath the Pacific for a distance of 12 or 13 miles. Its observed course to the northwest of Fort Ross, if projected southeasterly with a slight curvature, would strike the shore again at Bodega Head; and here it is found on the low ground of the isthmus that connects the head with the mainland. The Rift here coincides in position with a fault described by Osmont,<sup>1</sup> whereby the Franciscan rocks to the east are dropt down against the pre-Franciscan dioritic rocks of the headland. Immediately to the east of the fault-trace is a marsh. Across the mouth of the bay formed by the headland is a sandspit and the fault-trace should cross the spit near its abutment upon the shore line, but the drifting sands preclude its finding an expression here in geomorphic forms.

To the south of Bodega Head the Rift follows Tomales Bay (plate 6A) to its head near Point Reyes Station. This is a remarkably linear inlet of the ocean lying between Point Reyes Peninsula and the mainland, having a length of about 15 miles and not exceeding a mile in width. It has generally been regarded as a feature determined by a fault,<sup>2</sup> the same as that noted by Osmont at Bodega Head, whereby the Franciscan rocks of the mainland were brought against the pre-Franciscan granitic and dioritic rocks of the peninsula. The bay is quite shallow, but both of the slopes above the shore line are rather precipitous, and the ridge crests on either side attain elevations of over 1,000 foot. On the mainland side of the bay there are some rather vaguely defined terraces, both in the form of wave-cut benches and delta embankments. On the same side of the bay there are marine deposits of late Pleistocene age, containing abundant molluscan remains which have been elevated to about 25 feet above sea-level, and which are the equivalent of similar deposits at a similar elevation on the east side of San Pablo Bay.

<sup>1</sup> Hull. Dept. Geol., Univ. Cal., vol. 4, No. 3.

<sup>2</sup> Cf. Anderson, Geology of Point Keyes Peninsula, Bull. Dept. Geol., Univ. Cal., vol. 2, No. 5.

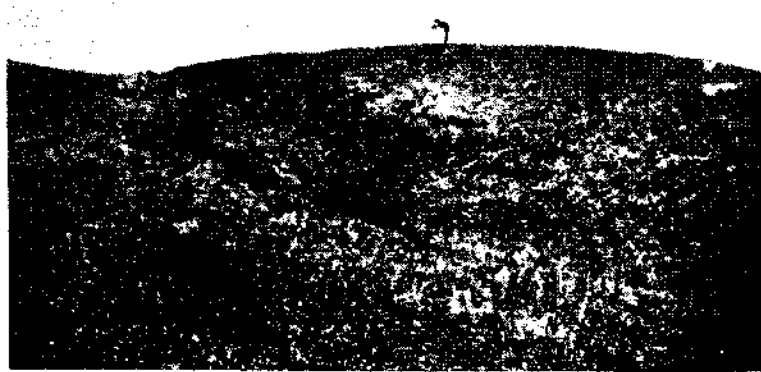

A



B



C



D

Characteristic Rift features near Fort Ross, Old scarps accentuated by new fault, Undrained ponds. F. E. M.

To the south of Tomales Bay the Rift lies in a remarkable defile with abnormal and ill-adjusted longitudinal drainage, which extends thru to Bolinas Bay, a distance of about 14 miles. On the east side of the defile is the steep coastal slope of the mainland, rising to a ridge crest from 1,000 to 1,700 feet in height. The transverse gullies in this slope are shallow, and detract but little from the general effect of a fairly regular but uneven steep slope. On the west is an even steeper but more incised and rugged slope, which forms the eastern edge of the peninsular land mass. This slope culminates in crests having an altitude of about 1,500 feet. The most striking geomorphic feature of the bottom of the defile is the presence of low ridges with intervening ravines or gullies elongated parallel to the general axis of the depression. More or less hummocky surfaces, with hillocks and hollows having no regular orientation, also occur. In the hollows ponds are fairly common features. The chief drainage is to Tomales Bay by Olema Creek, which heads within 2.5 miles of Bolinas Lagoon; and the divide between this stream and the parallel one which flows to the southeast has an altitude of about 400 feet above sea-level. The southeast end of the depression is submerged beneath sea-level, and is cut off from Bolinas Bay by a sandspit. The very shoal water inside of the sandspit is known as Bolinas Lagoon. (See plate 6B.)

The rocks on the east side of the defile belong wholly to the Franciscan series. On the west side, at the north end, we have chiefly the granitic and dioritic rocks of the peninsula with limited masses of crystalline limestone into which these rocks are intrusive. Farther south the granitic rocks are overlain by the shales of the Monterey series, and these rocks form the west side of the defile for several miles. The shales have inconstant and often very high dips. Still farther south the sandstones of the Merced series lie unconformably upon the Monterey shales, and near the town of Bolinas dip uniformly at moderately low angles toward the axis of the defile. It is thus apparent that the axis of the defile crosses more or less obliquely or transversely the contact between the Monterey and the granitic rocks, and also the contact between the Merced and the Monterey. It is also a remarkable fact that altho on the east side of the defile the Franciscan rocks constitute the mountain mass to a thickness of several thousand feet, this entire series, together with the Knoxville, Chico, Martinez, and Tejon, is almost entirely absent between the Monterey and the granitic rocks on the peninsula in the immediate vicinity. This indicates clearly that in pre-Monterey time the peninsular mass had been uplifted on a fault along the present coastal scarp, so that the granite was brought against the Franciscan and denuded of its unconformable mantle of sedimentary strata before it was submerged to receive the deposits of Monterey time. It is also clear that inasmuch as there is a great volume of Monterey shales on the peninsular or seaward side of this fault line, and no trace of the same formation on the mainland to the east of the fault line, one of two things must have happened. Either the submergence which permitted the deposition of the Monterey shales was confined to the peninsula and was effected by a downthrow of that block on the same fault as that upon which it had earlier been upthrust, so that there was no sea over the territory east of the fault; or, if the regions on both sides of the fault were submerged together, then in post-Monterey time the east side of the fault was lifted into the zone of erosion and denuded of its covering of Monterey shales so thoroly that no trace of them now remains. There is no escape from one or the other of these conclusions, and each of them involves a movement on the fault with relative downthrow on the southwest side, or the reverse of that which occurred in earlier, pre-Monterey time. From this interpretation it follows that the defile extending from Tomales Bay to Bolinas Bay lies along the trace of a fault which dates from pre-Miocene time, and that upon this fault there have been large movements in opposite directions so far as the vertical component of such movements is concerned. The trace of this ancient fault is also the line of the modern Rift.

The dip of the Merced beds at Bolinas toward the Franciscan rocks of the mainland is quite analogous to the dip of the same beds toward the Franciscan of San Bruno Mountain on the San Francisco Peninsula,<sup>1</sup> and has the same significance, viz., that the Merced beds have been relatively downthrown on the west against the older rocks. The fault in the Tomales-Bolinas defile has usually been regarded as identical with and a continuation of the San Bruno fault of San Francisco Peninsula, and there seems to be no good reason for changing this judgment, altho, as will appear shortly, the modern Rift to the south of the Golden Gate does not coincide with the trace of the San Bruno fault, but leaves it at a small angle and pursues a course nearly parallel, but to the southwest of it. It is noteworthy, also, that while on the Point Reyes Peninsula, particularly in the vicinity of Bolinas, there is a magnificent wave-cut terrace at an altitude of about 300 feet, with a width of 1 to 1.5 miles between the base of its sea-cliff and the brink of the present sea-cliff, no such feature is to be found on the landward side of the fault-line on the coastal scarp between Bolinas Lagoon and the Golden Gate.

*Characteristics of the Rift* (G. K. Gilbert, pp. 30-35).— In a broad sense the structural trough in which lie the two bays is a feature of the great Rift. In a narrower sense the Rift follows the lowest line of the trough, controlling the topography of a belt averaging 0.75 mile in width. The physiographic habit of the trough is that of a depression occasioned by faulting. It is remarkably straight. One wall, the southwestern, is comparatively steep; the other is comparatively gentle. The gentler slope is an inclined plateau with incised drainage. Viewing the trough from any commanding eminence, the physiographer readily frames a working hypothesis of faulting and tilting. He sees in the southwestern wall a fault-scarp of moderate freshness, and in the northwestern wall a slope originally less steep, in which erosion has been stimulated by uplift and tilting. The general facts of the geology of the district, as worked out by Anderson/ agree with this theory. The axial line of the valley is recognized by him as the locus of a fault, or fault-zone, and the rocks of the southwest wall are everywhere older than those which adjoin them at the base of the opposite slope. The gentler slope is well shown by plate 7A. Plates 8B and 41B also show something of the gentler slope, and plate 7B of the bolder.

In a general way the two slopes are drained by streams which descend to the axis of the valley, and are there gathered in two longitudinal trunk streams which flow severally to Tomales Bay and Bolinas Lagoon; but in a central belt following the lowest part of the trough the details of drainage are comparatively complex, and their complexity is associated with peculiarities of the relief which serve to distinguish the central belt from the bordering slopes. In the bordering slopes the subordinate ridges conform in normal manner to the drainage, having evidently been developed by the erosion of the canyons which separate them. In the axial belt the ridges are evidently independent of the drainage, often running athwart the courses which would normally be followed by the drainage. In part the ridges divert or control the drainage; in part the drainage traverses and interrupts the ridges.

The influence of the ridges on the drainage is illustrated by the accompanying diagrams. Fig. 2 shows the actual drainage system; fig. 3 the system which would be developed if there were no special conditions along the axial zone. The small ridges of the axial zone trend parallel to the axis, and their interference gives parallel courses to various streams which would otherwise unite. The influence of the drainage on the ridges is illustrated by fig. 4, which shows a small ridge resting on the side slope of a larger ridge. The drainage of the larger ridge breaks thru the smaller, making gaps. Plate 7B shows the slope of a greater ridge at the right; and at the left two bushy hills

<sup>1</sup> Cf. A Sketch of the Geology of the San Francisco Peninsula. U. S. G. S., 15th annual report.

<sup>8</sup> Geology of Point Reyes Peninsula, by F. M. Anderson. Bull. Dept. Geol., Univ. Cal., vol. 2, No. 5.

which are part of a flanking ridge dissected by cross-drainage. The flanking ridge appears also in the distance. In plate 8A the flanking ridge is broader; in plate 9A it is more nearly a terrace than a ridge.

Similar relations between ridges and drainage lines are found in regions of steeply inclined strata, each ridge being determined by the outcrop of a resistant formation, or at least all of the preceding description might apply to the topography of such a region; but other characters remain to be mentioned, and these serve for discrimination.

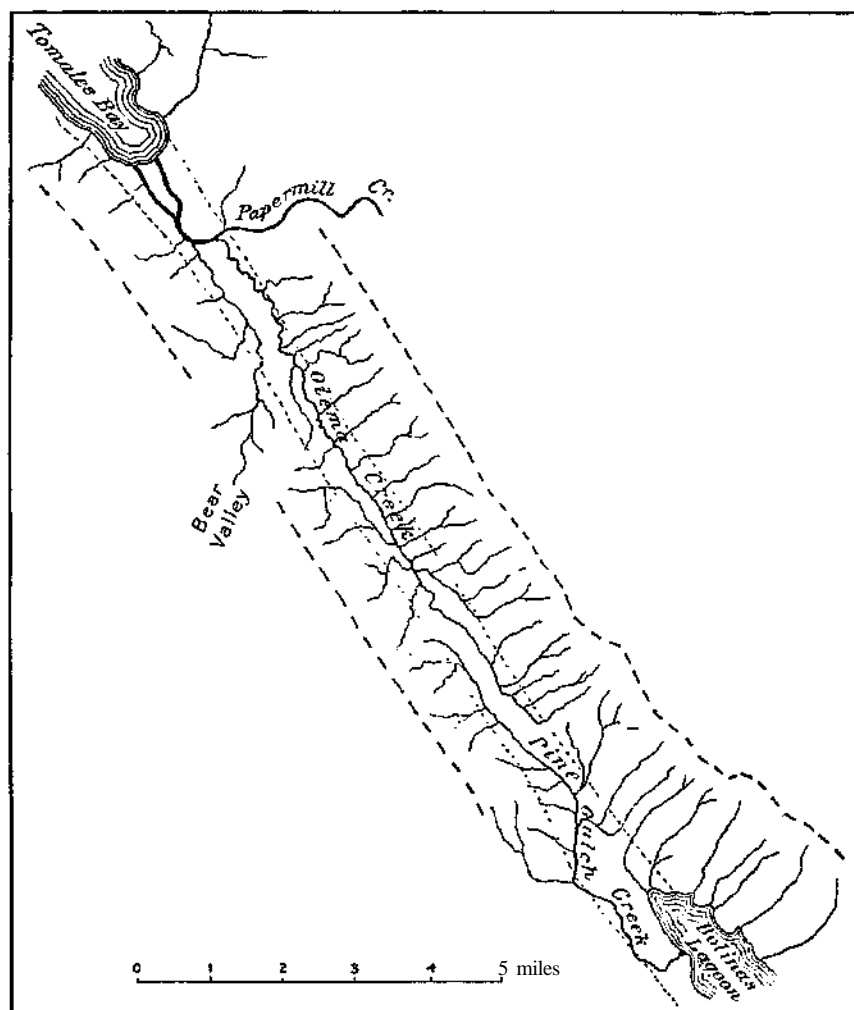

FIG. 2.—Drainage map of Bolinas-Tnmales Valley. Heavy broken lines show crests of bounding ridges. Light broken lines indicate limits of Rift topography.

Where a steep-sided ridge is determined by the presence of a resistant formation, the determining rock follows and usually outcrops along its crest; but in the ridges under consideration there are few rock outcrops, and such as occur are not systematically related to the crest lines. The formation of the crest is not always the same thru the whole length of the ridge, and it is not always a rock of such character as to resist erosion. Between the ridges are linear valleys, and many of these are occupied by streams, but in a number of instances they are crost by the drainage. Often they include local depressions, with ponds or small swamps, this character being so pronounced that forty-seven such ponds were seen between Papermill Creek and Bolinas Lagoon, a distance of 11



miles. (See plates 9B, 10, 43, 54A.) The valleys range in width from 20 or 30 feet to about 500 feet, the majority falling between 100 and 200 feet; and each of them is approximately uniform in width, unless occupied by a stream. In a typical cross-profile, the side of the valley is somewhat definitely distinguished from the bottom by a change of slope (see fig. 5), the distinction appearing at one or both sides.

In view of these characters, and especially of the abundance of ponds, it is evident that these little valleys are not products of stream erosion; and that in so far as they are occupied by streams the streams are adventitious. Their true explanation is suggested by their relation to certain of the earthquake phenomena of April, 1906. As will

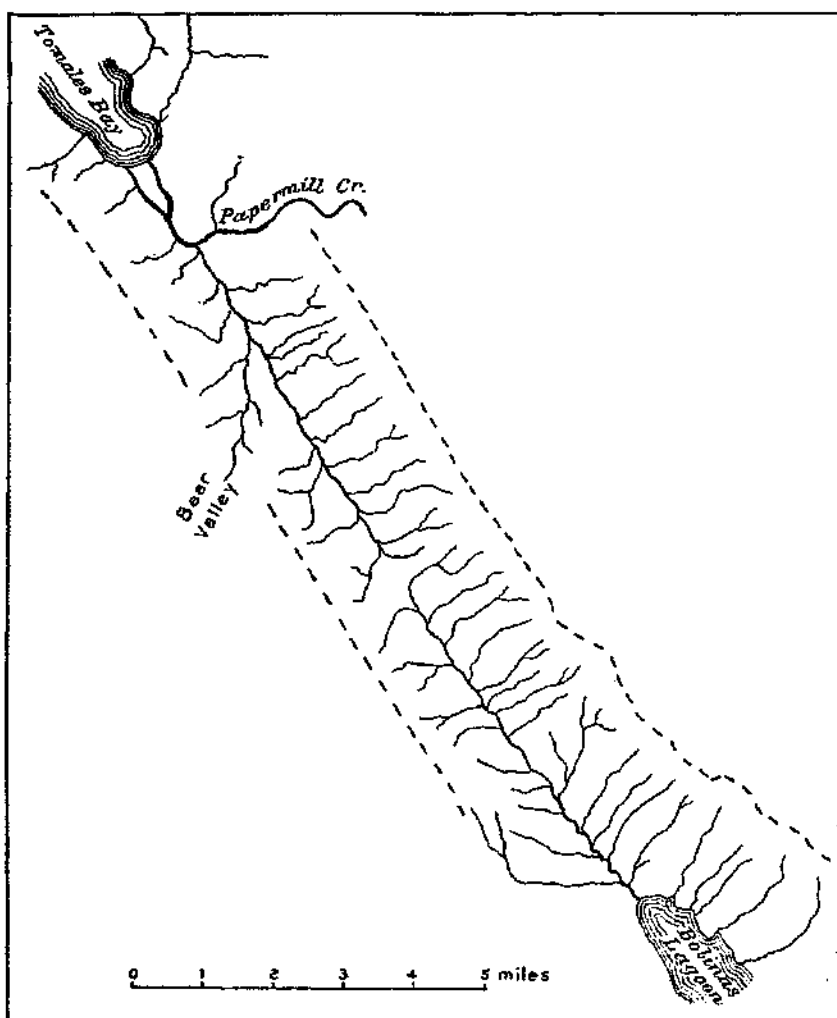

FIG. 3.—Hypothetic drainage map of Bolinas-Tomales Valley, if developed without influence of Rift displacement. Compare fig. 2.

presently be described in detail, the trace of the earthquake fault thru the greater part of its course in the larger valley follows the edge of one or another of these small valleys; and in places where the fault movement included vertical dislocation, such dislocation nearly always tended to increase the depth of the valley. (See plate 10B and fig. 6.) Of the numerous minor or secondary cracks developed by the earthquake in the immediate vicinity of the main fault, a considerable proportion occurred at the edges of the *Yitth*\* valleys, following more or less closely the line along which the bottom meets the side; and with these cracks also there was usually a little vertical dislocation, the ground



A. Looking down Tomales Bay from near Olema. H.W.F.



B. Looking down Bolinw Lagoon and Bay toward the Golden Gate. ViUage of Boli« » foregromd. H.W.F.



A. Looking north in the Bolinas-Tomales Valley. G. K. &

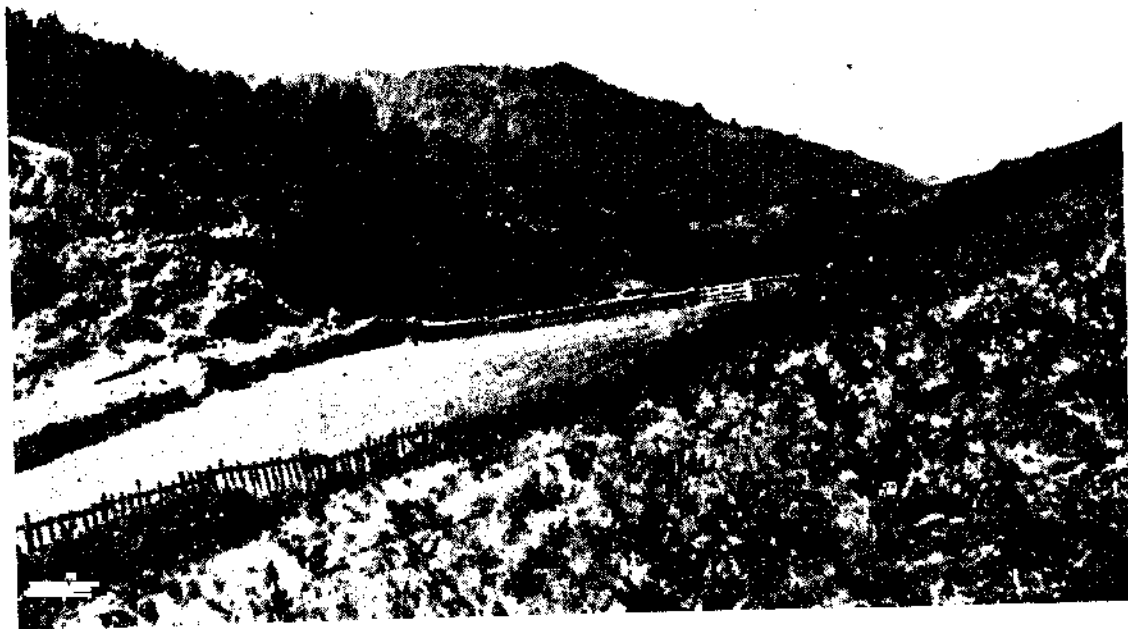

B. Fault-sag and side-Mil ridge near Boaditti's ranch. The fault-trace follows sag and appears, at left of field. O.K.O.

sinking a few inches on the side toward the middle of the valley. Thus the surface changes associated with the earthquake tended, within this belt, to increase the differentiation of the land into ridges and valleys; and it is easy to understand that the inception as well as the perpetuation of the ridges and valleys was due to faulting.

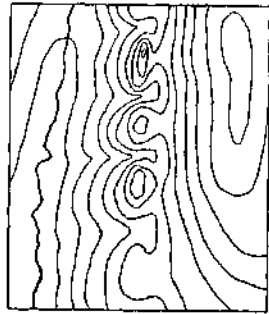

FIG. 4.—Map of side-hill ridge.

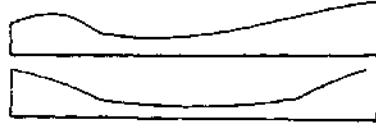

FIG. 5.—Cross-profiles of fault-sags.

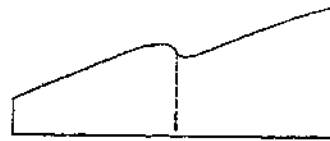

FIG. 6.—Cross-profile of side-hill sag shown in plates 7B and 10B.

Collectively these ridges and valleys occupy a belt from 0.5 to 1 mile in width, and constitute the local development of the Rift, using that term in its narrower sense. They make up the entire surface of the belt, except where overpowered by some vigorous creek. The individual ridges are not of great length, being 2 or 3 miles at the most, and usually much less. Some of them end by wedging out, others by dropping down until replaced in the same line of trend by valleys. Their greatest height above base, except where the adjacent valleys have been deepened by erosion, is about 150 feet. The narrower have straight, acute crests; the broader have undulating backs with more diversity of form than is shown by the associated valleys. Some are crossed by curved or straight depressions, and these depressions have all the characters of the parallel valleys, including the association of earthquake cracks.

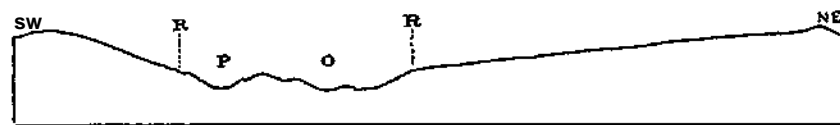

FIG. 7.—Cross-profile of Bolinas-Tomales Valley. Vertical and horizontal scales the same. RR = limits of Rift. P = valley of Pine Gukh Creek running SE. O = valley of Olema Creek running NW.

In the remainder of this report the term Rift will be applied only to the narrow belt just described. Regarding it as the surface expression of a great shear zone or compound fault, the ridges are the tops of minor earth-blocks, and the valleys are in part the tops of relatively depressed blocks and in part depressions resulting from the weathering of crushed rock. Considering the Rift as a physiographic type, I find it convenient to have a specific name for one of its elements, the small valley; and in some of the descriptions which follow I shall speak of it as a *fault-sag*. (See plates 7B, 8A, and 11.)

The general relation of the Rift to the greater valley is illustrated by the cross-profile in fig. 7. Along its northeastern side it everywhere lies lower than the adjacent slope of the greater valley, the produced profile of the valley slope passing above the fault-ridges as well as the fault-sags. Along its southwestern side some of the fault-ridges appear to project above the restored profile of the greater valley, while the fault-sags lie below. If I interpret the structure correctly, the great compound fault concerned in the making of the valley trough — a fault of which the vertical dislocation amounts to several thousand feet — includes a certain amount of step-faulting, which



FIG. a.—Ideal section across Rift corresponding to profile in fig. 7.

is responsible for some of the western ridges of the Rift belt; but with that exception, the ridges and sags of the Rift are occasioned by the unequal settling of small crust blocks along a magnified shear zone. (Fig. 8.)

The limits of the Rift are not definite. The boundaries drawn in fig. 2 serve to indicate the belt in which the Rift structure dominates the topography, but do not indicate the limits of the Rift structure. Within the belt the dislocations have been so re-

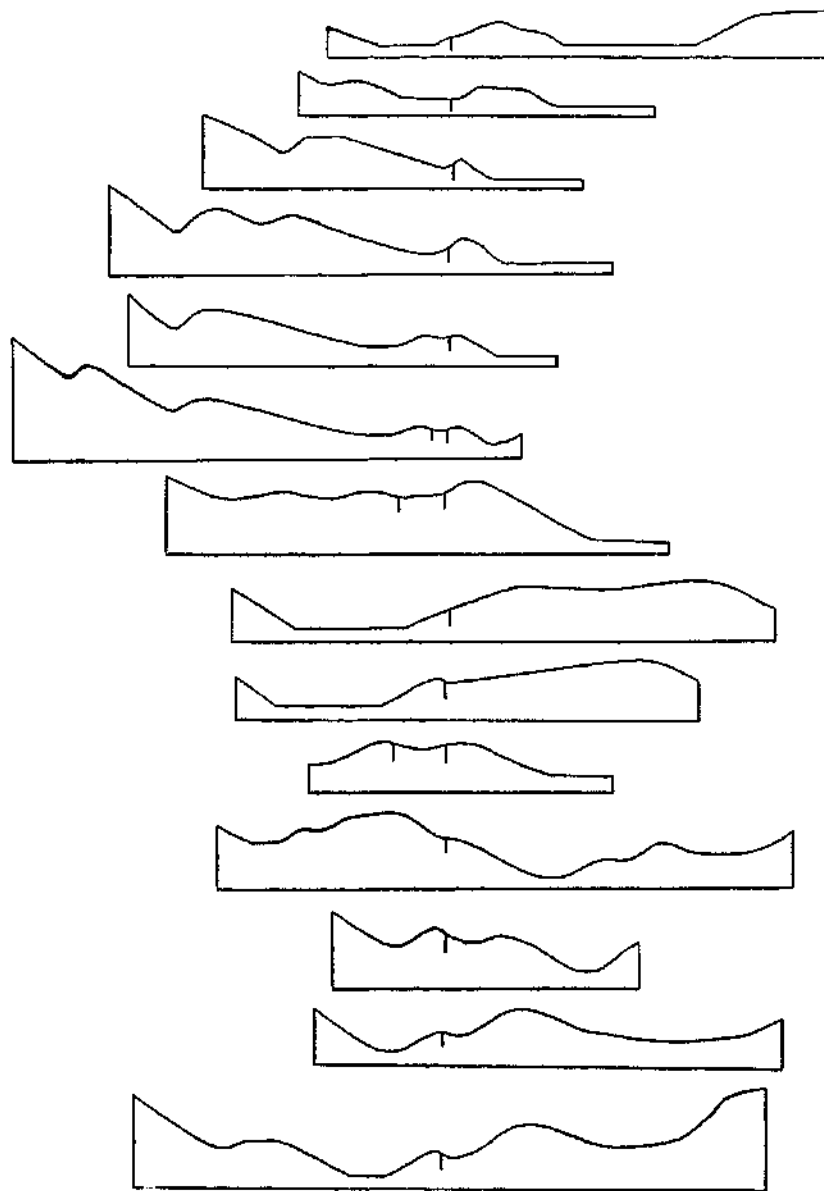
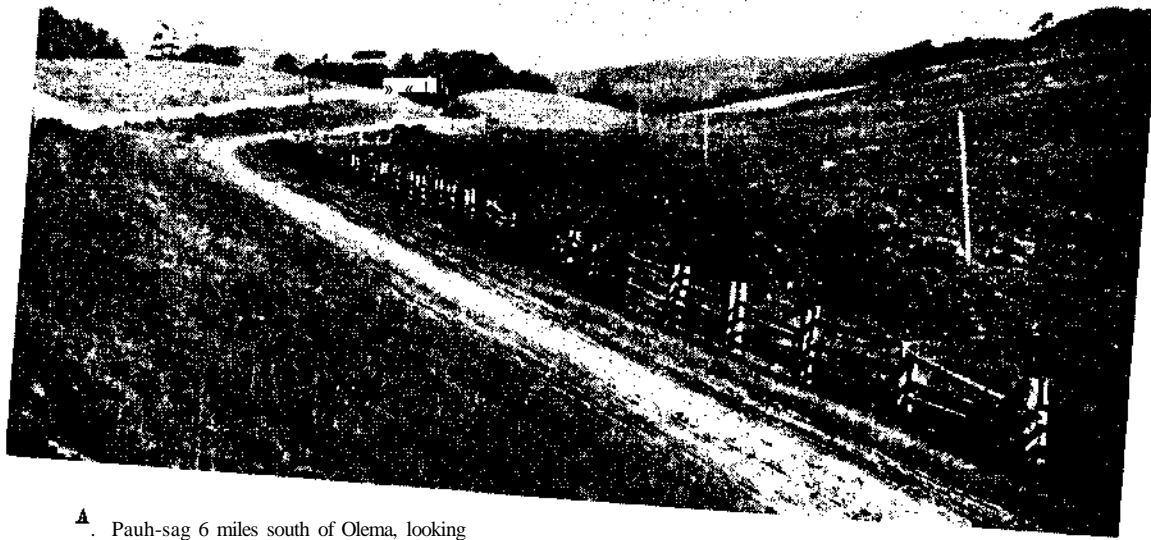

FIG. 9.—Cross-profiles of the Rift arranged in geographical order with the most northerly at top and northeast ends at the right. Positions of fault-trace and its branches are indicated. The profiles are copied from field sketches made without measurement.

cent and of such amount as to keep ahead of weathering and erosion, so that their expression has been little dimmed by the processes of aqueous sculpture. Outside the belt the evidences of recent dislocation are less striking, but nevertheless exist. The inter-stream ridges of the northeastern slope are here and there indented and creased in such a way as to indicate recent faults of small amount trending parallel to the Rift. In the vicinity



A. Pauh-sag 6 miles south of Olema, looking northwest. The drainage crosses the sag from right to left, *Q.Z.G.*



B. Side-hill ridge 4 miles south of Olema, looking northwest.



A. Side-hill ridge *i* miles south of Olema, looking southeast. G. K. Q.



B. Eift tepsgraphy, with pond, a mij« \$mtk ef OS«a, lookiag seatleagt. Q. K. G.



A. Eift topography, with pond, near Bondietti's ranch, looking southeast. G. K. G.



B. The fault-trace near Bondietti'a ranch, looking west. Ilkitrafes the aisociatios of Tertical displacement with faait-sags aad ponds. G. K. Gh



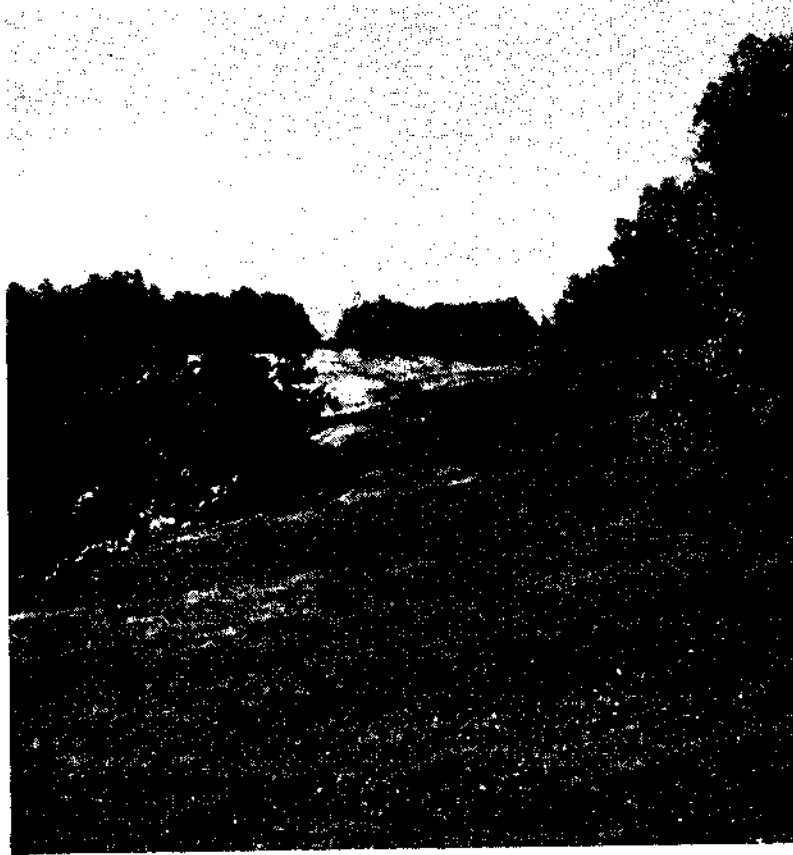

A. Fault-sag 2 miles south of Olema, looking southeast. G. K. G.

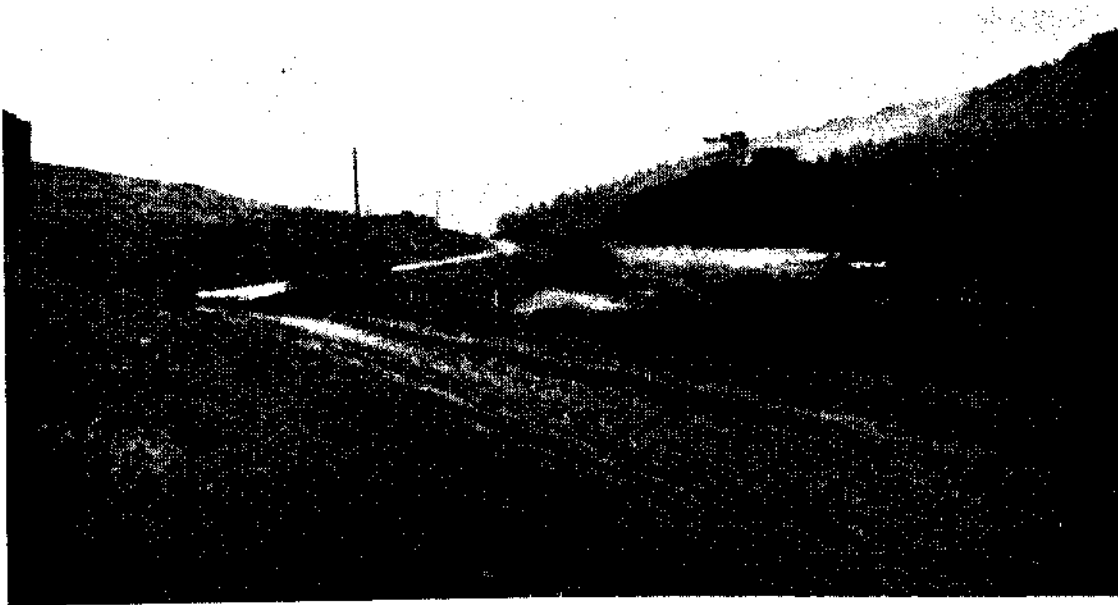

B. Fault-sag 3 miles south of Olema, looking southeast. G. K. G.

of both Bolinas Lagoon and Tomales Bay such features grade into dislocation terraces of greater magnitude, which originated at earlier dates but may have been recently accentuated. There are also narrow terraces of displacement on the comparatively steep face of the ridge southwest of the Rift, and at two points there are minor crests and associated canyons parallel to the main crest and to the Rift. So little is known of the local details of geologic structure that a different explanation of these creases, terraces, and spurs is not altogether barred; but their physiographic relation to the Rift features is so intimate as to leave little question in my mind of their genetic similarity. Assuming that they are correctly explained as the product of minor faulting of only moderate antiquity, they serve to connect the great trough containing the bays with the narrow belt of peculiar and striking topography, and indicate these as parts of a single great phenomenon — a belt which has been the locus of complicated fissuring and dislocation during the later geologic epochs.

#### MUSSEL ROCK TO PAJARO RIVER.

From Bolinas to the vicinity of Mussel Rock, about 8 miles south of the Golden Gate, the course of the Rift is beneath the waters of the Pacific, across the bar in front of the entrance to the harbor. Near Mussel Rock it intersects the shore at a great landslide (plate 12A) in rocks of the Merced series. At Mussel Rock, the basal beds of the Merced series rest directly upon an old land surface of worn-down Mesozoic rocks, and the basal bed contains abundant cones of *Pinus insignis* resting upon cemented alluvium. The cone-bearing bed immediately underlies marine strata and numerous fossils occur near the base of the series at the top of the ridge. The Merced strata here have a dip of about 15° to the northeast. The contact between the Merced and the older rocks trends southeast across the peninsula; and for some miles the Rift is approximately coincident with the trace of the contact and, for some portions of this distance, exactly so. From the shore line the course of the Rift is the same as that of the steep cliffs which rise at the back of the Mussel Rock slide to an altitude of over 700 feet. From the top of these cliffs, at an elevation of about 500 feet above sea-level, the course of the Rift as far as San Andreas Lake is marked by a line of shallow longitudinal depressions, ponds, and low scarps. (See plate 12B, 13, and 14.) There are eight ponds in this stretch of about 4.5 miles. This portion of the modern Rift was recognized as such in 1893.<sup>1</sup>

At a point about 4 miles from the Mussel Rock slide, the longitudinal depression which marks the course of the Rift becomes much more pronounced and passes into a remarkably straight and deeply trenched valley, the greater part of which has been converted by large dams into the San Andreas and Crystal Springs Lakes, used as reservoirs by the Spring Valley Water Company as water supply for the city of San Francisco. This straight valley (see plate No. 15) has an extent of 15 miles with a steady course of S. 34° E. to a flat divide southwest of Redwood City, whereby one passes over into the end of a similar but less pronounced valley, in which are situated Woodside and Portola. The San Andreas and Crystal Springs Lakes valley is almost wholly in the Franciscan terrane and the axis of the valley is discordant with the structural lines and contact planes of its constituent formations and intrusive masses. At the upper end of San Andreas Lake, however, the southwest edge of the Merced terrane forms in part the boundary of the valley on the northeast side for a short distance. The valley as a geomorphic feature (plate 16A) dates back fairly well into the Pleistocene. It is drained

<sup>1</sup> "The line of demarkation between the Pliocene and the Mesozoic rocks, which extends from Mussel Rock southeastward, is in part also the trace of a post-Pliocene fault. The great slide on the north side of Mussel Rock is near the land terminus of this fault-zone, where it intersects the shore line. Movement on this fault-zone is still in progress. A series of depressions or sinks, occupied by ponds, marks its course. Modern fault-scarps in the Pliocene terrane are features of the country traversed by it." The Post-Pliocene Diastrophism of the Coast of Southern California, by Andrew C. Lawson, Hull. Dept. Geol., Univ. Cal., vol. 1, No. 4, pp. 15U-151.

by San Mateo Creek which flows in a sharp gorge thru the wider part of the broad, flat-topped ridge which separates the valley from the Bay of San Francisco. This stream is regarded as a relic of the original consequent drainage of the northeast slope of Montara Mountain, which became superimposed upon the Franciscan terrane by the denudation of the overlying soft and little coherent Merced formations. From this consequent trunk the valley in which San Andreas and Crystal Springs Lakes now lie was evolved by subsequent erosion along the line of the Rift, its present features dating from a period in the Pleistocene later than the removal of the Merced formations. A small portion of the upper end of the valley has been captured by the headwater erosion of San Bruno Creek.

To the southeast of Crystal Springs Lake, the valley followed thus far bifurcates about 2 miles beyond the lake, on either side of a median ridge. The two branches are nearly parallel. The east branch rises to a wide and rather flat divide, with streams heading in it from both sides. The other branch, altho it is more incisive, has no well-defined stream, but has a small swamp at its lower end. It rises to a sharper divide, from which there is a descent into the narrow straight canyon of West Union Creek. It is this western depression that the Rift follows. Near Woodside the canyon of West Union Creek expands into a more open valley, with steep mountains on the southwest and lower hills on the northeast. The Rift follows this straight valley (plate 16B) to its southeastern end, and then ascends to the saddle which separates Black Mountain from the mountains to the west. From this saddle it descends to the narrow canyon of Stevens Creek. It crosses the canyon at a small angle near its upper end and parallels the creek on the southwestern side, at an elevation of about 500 feet above it. It then passes thru the saddle between Stevens Creek Canyon and Congress Springs, and keeps well up on the slopes to the west of Congress Springs behind a series of shoulders and knolls to a reservoir on a saddle thru which it passes. From this saddle southeastward the line of the Rift again lies along the southwest side of a longitudinal valley and so continues on a line independent of the present drainage to the pronounced notch in the crest line of the range at Wright Station.

In this stretch of the Rift from Crystal Springs to Wright, the coincidence of the Rift with the major geomorphic features is very striking for the first half of the distance. In the second half, if we judge by the fault-trace, it appears to be quite independent of, tho parallel to, the canyons; and its only manifest relationship to the geomorphic features is its coincidence with a series of saddles or windgaps in the transverse spurs of the mountains. Its general parallelism with, and proximity to, the crest of the range thruout the entire stretch is pronounced. In the notch at Wright, the Rift intersects the crest line and passes from the northeastern flank of the range to the southwestern.

The general features of the Rift from Wright to Chittenden are described by Mr. E. S. Larsen in the following note:

From the hills above Wright Station to the village of Burrell, a distance of about 2 miles, the Rift follows along the ridge above Los Gatos Creek, which drains to the east. The drainage of the western slope of the ridge is to the Pacific. For most of this distance the Rift is a short distance on the Los Gatos Creek side. It usually occupies a small, trough-like depression; or, where it cuts just above the heads of the small gullies, there are low, rounded knolls between the gullies. These knolls are seldom over 30 feet higher than the trough. Just southeast of Burrell, the Rift traverses the ridge and follows a gully into Burrell Creek, which it crosses. It continues in a southeasterly direction, parallel to the creek and about halfway up the ridge to the southwest of it. The elevation of the ridge is only about 400 or 500 feet above the creek bed, and the top is rounded, with a steep slope below this to the Rift, and a gentle slope below the Rift

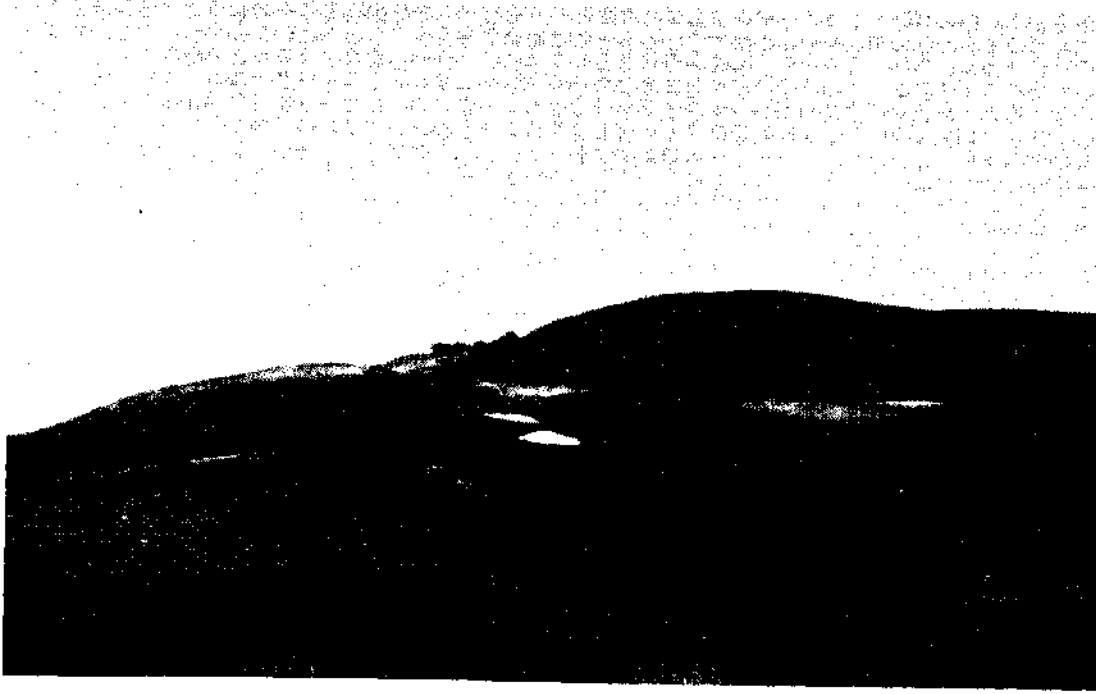

A. Great landslide at Mussel Eook, where the Eift enters the Ooast from the Paiofio. H. O. W.

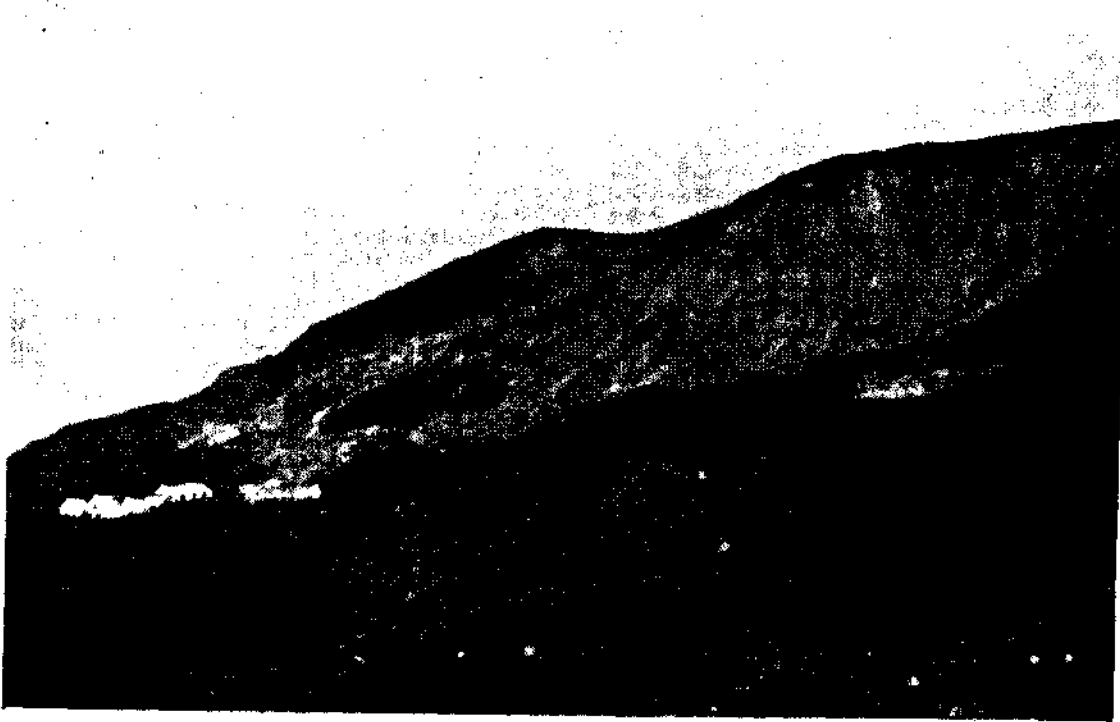

B. Looking northwest along the Eift. The iandalide is jwtt beyond the bonne, H. O. W.

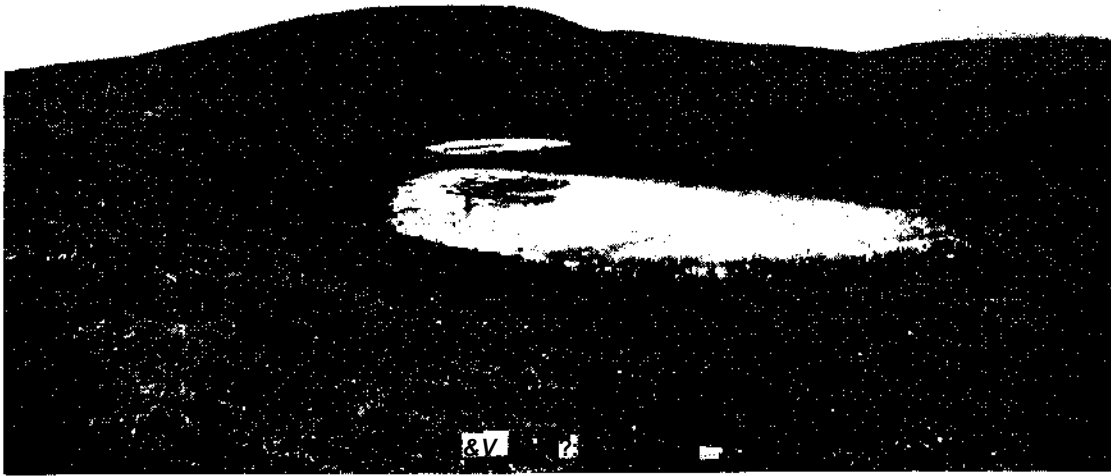

A



B

Characteristic ponds along the Eift soatht«t of Mass«l Bock. H. O. W.



A



C



B



D

Features of the Rift between Mussel Rock and San Andreas Lake, H. O. W.

to the creek. Near Burrell the slope is very gentle at the Rift, for from 20 to 50 feet, but is steep above and below. Looking up the Rift and the creek from this point, one gets the impression of a long straight creek, but in reality the view is over the divide, down a small tributary of Soquelle Creek to its junction with the main stream and thence up the main Soquelle Creek. About 2.5 miles from Burrell the Rift follows a small gully into Soquelle Creek, which it crosses where the creek makes a sharp turn to the west. For the next 4 miles, or to the point where the new county road crosses the divide between a branch of Soquelle Creek and Eureka Creek, it follows near the top of the timbered ridge to the southwest of Soquelle Creek. The heavy timber obscures the topography, but the Rift, wherever crossed, is marked by a bench or trough on the hillside.

Following the Rift to the southeast, it passes at the divide into the head of Eureka Canyon, rises on the northeast bank, and slowly gets farther away from the creek, cutting across the tributary creeks and rarely following one of the smaller gulches for a short distance. The typical section here gives a steep slope on the high hills to the northeast, then about 0.25 mile of gently sloping, rolling hills, and finally the steep slope to the creek itself. The Rift is on the gentle slope, generally at some distance from either of the changes in slope. This continues for about a distance of 2 miles on to Grizzly Flat. Here the high steep hills to the northeast are separated from the lower hills to the southwest by a flat about 500 feet across. The Rift is on this flat near its center, and usually marks the northeast boundary of a series of low knolls. It continues on the flat for about 0.5 mile to where the hills close together and leave a rather steep-walled gulch. The Rift follows up this gulch for about a mile, and then crosses into the head of another creek, which it follows down for about 3 miles, where the stream turns sharply to the north. For the upper mile the gulch is rather sharp and deep, but at Hazel Dell the hills on both sides are low and rolling, while the lower mile is again rather steep, opening at the turn to a rather flat country. At Hazel Dell and other points, the Rift occupies a small but distinct trough very near the southwest bank of the creek. From here to Chittenden, a distance of about 8 miles, it follows parallel to Pajaro Valley, well up on the hills, and cuts across the canyons at almost right angles.

The typical section up one of these ridges gives a gentle slope from the valley to an elevation of about 1,000 feet; a steep slope for about 50 feet in the opposite direction, which marks the Rift; a very gentle slope for about 1,000 feet across; and finally, the steep upper slope of the hills. Over this area the Rift is nearly always marked by a trough, which often gives rise to a small lake perched on a ridge between two steep canyons. At a few points, especially about a mile northwest of Chittenden, small streams and gullies tend to follow the Rift, and they then make a sharp turn where they leave it. At Chittenden the Rift again passes thru a pronounced notch in the crest of the range occupied by the canyon of Pajaro River (plate 17A), from the western flank of the dominant ridge of the Santa Cruz Range to the eastern flank of the Gavilan Range.

The rocks traversed by the Rift from Mussel Rock to Pajaro River are, so far as known, almost wholly confined to the Franciscan and Monterey series, the former prevailing in the northern part and the latter occurring only in the southern. At Pajaro River the Rift encounters the granitic rocks of the Gavilan Range, but these lie wholly on its western side.

## PAJARO RIVER TO THE NORTH END OF THE COLORADO DESERT.

BY H. W. FAIRBANKS.

The earthquake of April 18, 1906, opened and displaced the walls of the old fault along the Rift as far south as the town of San Juan in San Benito County. The fault-trace passes directly under the western span of the Southern Pacific Railroad bridge across San Juan River, as shown by the displacement of the piers at the end of the bridge, a distance of 3.5 feet. For a distance of nearly half a mile on either side of the bridge, the river has established itself in the Rift. To the northwest the steep slopes of Mount Pajaro facing the canyon do not show any regular fissure. This does not, however, indicate any discontinuity in the fault, for the surface of the whole mountain is more or less broken by auxiliary cracks, secondary fissures, and slides.

Southeast over the hills from the point where the Rift leaves the river, the characteristic features of the Rift make their appearance. It is marked by a small pond (plate 17B), springs, and a more or less continuous ridge with its steeper face toward the southwest. The fissure of the recent earthquake follows this series of features (plate 18A), and, at a point halfway between the bridge and San Juan, there is shown in a broken fence a horizontal displacement of 4 feet. A mile before reaching San Juan, granitic rocks are exposed upon the southwest side of the Rift. Shortly beyond this point the Rift leaves the hills and traverses the western edge of the valley of the San Benito River. The ridge which we have been following is now lost in the level floor of the valley, but as far as traceable its course is directly toward the low bluff upon the eastern edge of the town of San Juan. The fissure of the recent earthquake is to be seen where it crosses the road 0.5 mile northwest of San Juan, but has not been noted farther along the old Rift line. It appears to bend more easterly, and this probably connects it with the disturbances of the earth between Hollister and San Juan. Mr. Abbe, of San Juan, states that the earthquake of 1890 opened the old Rift and that the displacement of the walls, tho small, was in the same direction as in the recent earthquake.

The town of San Juan stands upon a bench of gravel which dips gently in a southwesterly direction, but upon its northeastern side presents a steep face which, near the old mission, has a height of about 50 feet. This bluff is marked thruout its length of 0.5 mile by several springs; and there can be little doubt that it owes its existence to a fault movement uplifting and tilting toward the southwest a portion of the floor of the valley, and that it thus originated in the same way as other similar features which we shall find to be characteristic of the Rift. The Rift leaves the valley southeast of San Juan and gradually rises along the eastern slope of the Gavilan Range. It intersects the head of San Juan Canyon, and has here given rise to an interesting modification of the drainage. San Juan Canyon is long and narrow and is formed by the union of several small streams which, rising upon the higher slopes of the range, pursue a normal course toward the San Benito Valley, until reaching the Rift, they turn northwest and slightly away from the fracture line, giving rise to San Juan Canyon. At the point where the Rift intersects the canyon, the narrow ridge between the canyon and the valley has been broken thru, and the whole drainage passes directly down the mountain, abandoning the canyon, which is now filling with delwis fan material.

For about 10 miles southeast from the head of San Juan Canyon, the Rift follows the eastern slope of the Gavilan Range. It is marked by small valleys and gulches, by hollows and ridges upon whose sides oak trees are growing; and it is followed almost continuously by a wagon road. One of the most interesting features along this portion of the Rift is Green Valley, a broad cienega due to the filling up with gravels and silt of a valley lying close under the steeper portion of the Gavilan Range. There are two fault-lines below the valley and about 0.25 mile apart. The cienega is due to vertical



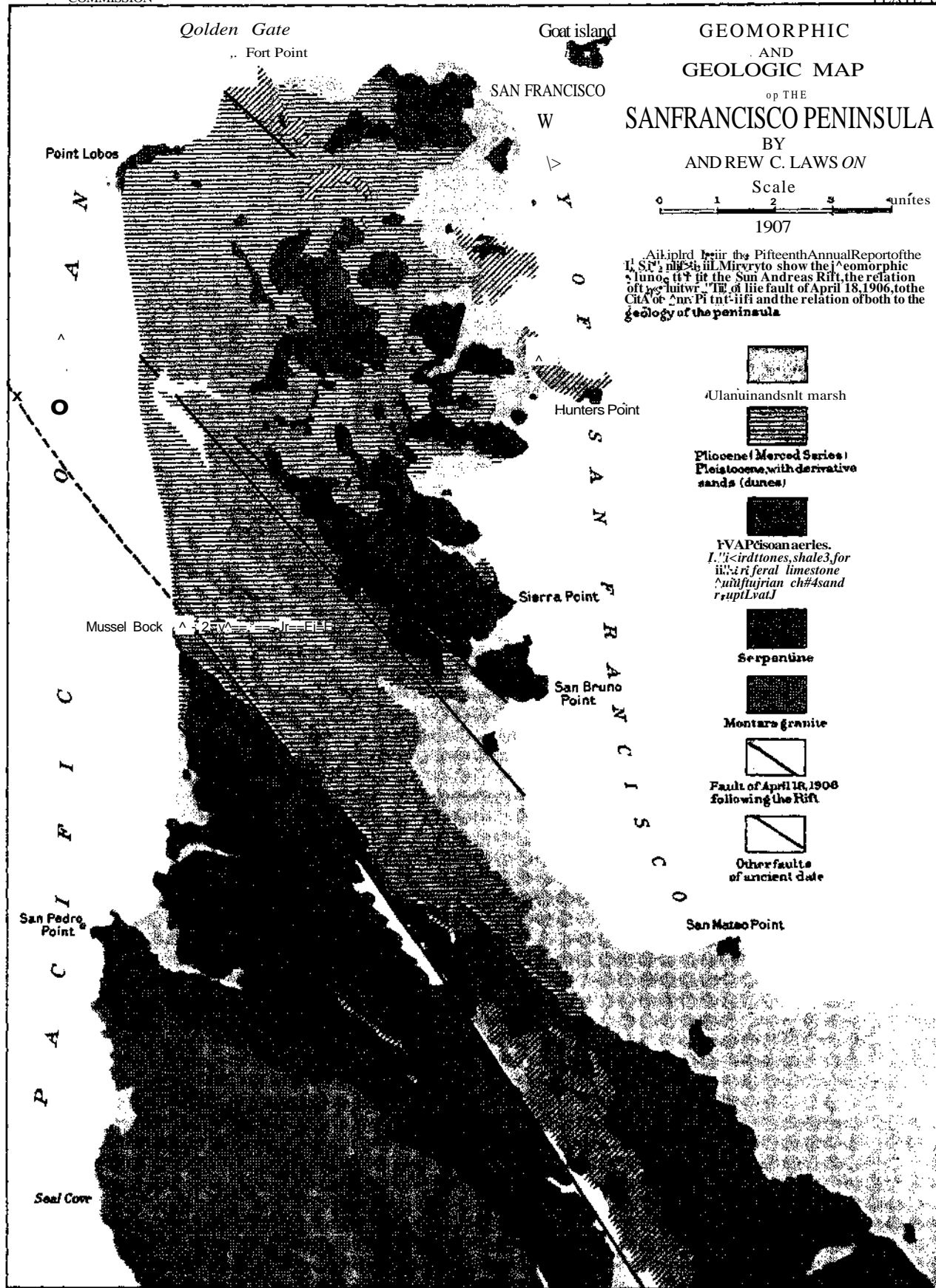



A. The Eift valley between San Andreas lake and Crystal Springs, looking southwest. ^It-trace parallel to fence about 50 feet beyond. Auxiliary cracks in the foreground at an angle of 40° with it. J. U. B.



B. The Eift *mlhj* 5 milei west of Stanford Unirenty. Faalt-traoe in fowground. Per J. O.B.



A. The Eift followed by tie Pajaro River at Ohittenden, Dislocated bridge supported by false work. H.W. F.



B. The Eift a mile soatheast of CiitteadsE, Poad oa apper slope of hill. H. V. F.

displacement along the upper line, which has raised a ridge of the old crystalline rocks across the valley. This dam must first have given rise to a lake, but as this filled up with the wash brought down from the mountains, a marshy meadow took its place. The oldest resident in the district says that the earthquake of 1868 formed a small lake in the lower portion of the cienega. The great body of gravels filling the old valley acts as an important reservoir of water. The city of Hollister has taken advantage of this fact to secure a water supply. By tunneling thru the rock barrier, the gravels are reached and the water led away in pipes.

The Rift comes out upon the San Benito River 4 miles above Paicenes P.O. For several miles up the river from this point, the Rift line is masked by the recent flood plain. Above Mulberry P.O., and just before coming to the bridge across the river, a most striking and interesting feature appears. Upon the east side of the river, and separated from it by a ridge, is a narrow depression half a mile long and 75 feet deep, without any external drainage. The ridge between it and the river extends a mile northwest of the sink, and presents a steep face to the northeast. The road passes along the eastern base of the ridge and opposite the sink makes use of its even crest. The river makes a sharp bend at the bridge, and the Rift crosses to the west side. Faulting has here brought to the surface, upon the west side of the Rift, limestones associated with the crystalline schists and granitic rocks of the Gavilan Range.

In order to follow the Rift beyond the mouth of Willow Creek, we leave the San Benito River road at the mouth of the creek and follow to its head a long narrow canyon which has evidently been eroded on the line of fracture. At the head of the canyon we come out upon a bit of open rolling country which, but for a low ridge, would drain into the San Benito. This ridge has evidently been raised along the Rift, diverting a stream which would naturally be tributary to the San Benito, so that now it forms the head of Bear Creek and flows down past the Chelone peaks into the Salinas River. Several undrained hollows (plate 18B) mark the Rift as it follows the ridge between Bear Valley and San Benito River. The formation of both walls is probably of Tertiary age up to a point near San Benito P.O., where the Franciscan series constitutes the southwest side and the Tertiary the northeast. South of San Benito P.O., there is a considerable area where the surface has been much changed as a result of some one of the movements along the old Rift. A fertile valley, perhaps 0.5 mile long, appears to have been formed thru subsidence, while on the southwest is an abrupt ridge 200 feet high and fully a mile long. The ridge without doubt has been produced by faulting. Its abrupt northeastern face and long, gentle, southwesterly slope suggest in a remarkable manner the great fault blocks of the west, such as the Sierra Nevada Range. The ridge gradually sinks in a southeasterly direction, blending with Dry Lake Valley. The latter is about 2 miles across and has no external drainage. The fault-scarp already mentioned extends as a low ridge part way across the valley and is utilized by the road.

Looking southeast across the valley in the direction which the Rift pursues, a mountain is seen which seems to have been sharply cut off. Descending a narrow valley to the southeast of Dry Lake Valley, we reach the foot of a steep escarpment (plate 19A) where there are apparent two, and possibly three, lines of displacement. The middle one passes at the foot of the main cliff, which is between 400 and 500 feet high. It can not be said with certainty that the whole cliff is the result of faulting, altho it is certainly so in part. The formation in the cliff is sandstone of either Tertiary or Cretaceous age. About 5 miles northwest of Bitterwater there is an interesting valley which has been so disturbed that it has no external drainage, while thru its center passes a ridge formed along the Rift. The ridge forms a fine roadbed. Descending toward Bitterwater Valley and P.O., another ridge appears which is as even and regular as a railroad grade. Bitterwater Valley is occupied during the wet season by a marshy lake.

The depression is probably associated in some manner with one of the movements along the Rift. Upon the eastern edge of the valley there is an escarpment about 100 feet high, due to an upward movement upon the northeast side of the Rift.

Southeast of Bitterwater, the Rift leaves the younger formation, and at Lewis Creek both walls are in the Franciscan rocks. For 20 or 25 miles now, the peculiar features of the Rift by which we have followed it are almost absent. The Franciscan series, including old sedimentary rocks, serpentines, and other basic igneous rocks, does not lend itself well to the preservation of such records, but appears to be greatly broken and crushed and marked by enormous landslides in the vicinity of the Rift. The Rift crosses Lewis Creek about 2 miles above its mouth and then passes up over a high ridge lying between Lewis Creek and San Lorenzo Creek. On the north side of Lewis Creek there is an enormous landslide, which has nearly blocked the valley. The slide is undoubtedly hundreds of years old. The ridge on to which the Rift passes after leaving Lewis Creek is crossed by it at such a small angle that it does not reach the southern base until we get to the head of Peach Tree Valley, a distance of 20 miles. The ridge its whole length is shattered and broken, and, as before said, marked by innumerable rockslides. The rather steep slopes appear to move every wet season. The headwaters of the San Lorenzo Creek (Peach Tree Valley) have been robbed by Gaviota Creek, possibly as a result of some movement connected with the Rift. Just above where the stream has been diverted, there is another great landslide which the road crosses to reach Slack Canyon.

At the mouth of Slack Canyon, the Rift leaves the Franciscan series, and coincides again with an ancient fault in which the Miocene sandstones are thrown down upon the southwest against the older formation just referred to. Passing from Slack Canyon over a divide, we come to the headwaters of Indian Creek and Nelson Canyon. As the Rift occupies steep slopes much of this distance, it is distinguished chiefly by landslides and rapid gullying of the surface. In Nelson Canyon the Rift follows an old fault in which the Miocene formation has been thrown down upon the southwest side, and the northeast wall so raised that the granite on which the Franciscan series rests is exposed. Ascending the divide toward the head of Nelson Canyon, a long, nearly straight ridge of Miocene clays divides the drainage and appears to be due to some one of the movements along the Rift.

The Rift can be traced thru the hills at the head of the Cholame Valley by its characteristic features, as well as by bluffs which are undergoing rapid erosion. It crosses the road a mile west of Parkfield and exhibits here a regularly rounded ridge 200 feet wide and 20 feet high at the most elevated point. (Plate 19B.) That the ridge must be hundreds of years old is shown by the great oak trees that are growing upon it. One white oak is fully 8 feet thru. Large springs mark the fissure at this point, and are found along it the whole length of the Cholame Valley. According to a resident, the Rift opened along the ridge in the earthquake of 1901, the opening being distinctly traceable for several miles. Southeasterly from the point just described thru the Cholame Valley, there appears no very prominent ridge or escarpment, altho springs and cienegas, marking a gentle swell in the flat open surface of the valley, indicate the line of the Rift.

The region about Parkfield, in the upper Cholame Valley, has been subjected to more frequent and violent disturbances than almost any other portion of the entire Rift. An auxiliary fissure begins near the main Rift a little west of Parkfield, and extends in a more easterly direction along the east side of Cholame Creek. (See plate 20.) The once flat, open valley has been broken along this line, and a bluff nearly 200 feet high formed facing the Creek. This bluff, now deeply eroded, must have been formed during one of the most disturbances. The lowland between this bluff and Cholame Creek shows the effect of great disturbance over a considerable area. Innumerable hollows interlace and extend in all directions. They resemble nearly obliterated creek beds except that they have no outlets. Parallel with the front of the dissected bluff, but a little back from



A. Looking northwest along the Eift 3 miles southeast of Ohittenden. H. W. P.



B. Ponds along lift near San Benito. H. W. P.



A. The Eift 2 miles soTith of Dry Lake Valley, San Benito Oouty. H.W.F.



B. Ancient scarp <a the line of the Rift a mile weit of Parkfield, Cholame Valley. H.W.F.



A. A branch of the Rift 2 miles southeast of Paikfield, Oholame Valley. H.W.P.



B. Another view of the same. H. W. P.



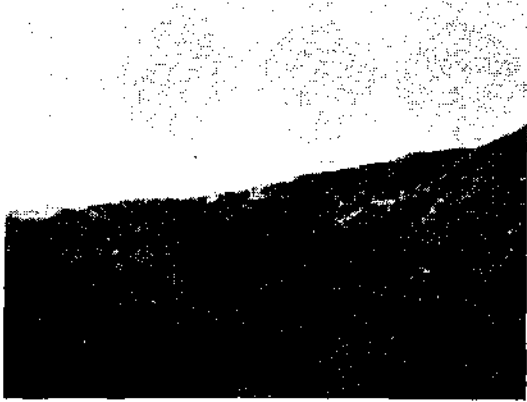

A. Rift, northeast side Oarissa Plain. A. O. L., Jan., 1906.



B. Eift, northeaat aide Oarissa, Plain. A. O. L., Jan., 1906.



C. Eift, northeast side Oarissa Plain. A. O. L., Jan., 1906.



D. Eift, jnst beyond southeast end Oarissa Plain, A. O. L., Jan., 1908.



E. Eift, jnst beyond southeast end Carissa Plain. A. O. L., Jan., 1906.

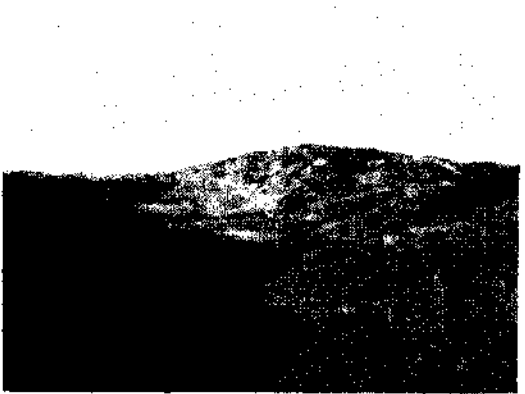

F. Eift, just beyond southeast end Carissa Plain. A. G. L., Jan., 1906.

its upper edge, are two parallel lines of faulting, probably made at a later date than the bluff itself. A small lake occupies a hollow in one. The slopes of one of these V-shaped depressions are quite steep, pointing to a comparatively recent origin.

The people living along the Rift for 150 miles southeastward from the Cholame Valley tell wonderful stories of openings made in the earth by the earthquake of 1857. The first settler in Cholame Valley was erecting his cabin at that time, and it was shaken down. The surface was changed and springs broke out where there had been none before. In 1901 a fissure opened in the road which crosses the branch fault just described. After each successive shake it is reported that the fissure opened anew, so that the road had to be repaired again in order to be passable.

Upon the western side of the Cholame Valley, near its southern end, the main Rift again exhibits an interesting bluff which cuts off the debris fans of the back-lying hills. This bluff faces northeasterly. Where the Rift crosses the creek as it passes out of the Cholame Valley, a low escarpment was formed upon the west side which must for a time have dammed the creek and given rise to a lake. From the outlet of the Cholame Valley the Rift line can be seen as it rises along the low rolling hills, and disappears over their tops. It is marked by a distinctly steeper slope facing northwesterly, showing that an uplift of 30 to 50 feet took place upon the west side. The region traversed thru the Cholame Valley southeast to the Carissa Plain and for some miles beyond, exhibits no older formation than the Miocene Tertiary, the effects of older faulting, if such has occurred here, being masked by recent deposits. Continuing the examination toward the southeast, the writer came upon the Rift at the northern end of the Carissa Plain, 4 miles northeast of Simmler P.O., and in direct line with its course where last seen. Here the width of the broken country is much greater than usual, being nearly a mile. A number of lines of displacement can be distinguished; some nearly obliterated, others comparatively fresh. This is a region of light rainfall and of gentle, grass-covered slopes, presenting just such conditions as would preserve for hundreds of years the effects of moderate displacements.

The Rift zone continues to be traceable along the western base of the Temblor Range, finally passing out on to the gently rolling surface of the eastern edge of Carissa Plain. Broken and irregular slopes, cut-off ridges, blocked ravines, and hollows which are white with alkaline deposits from standing water mark the Rift. Carissa Plain has a length of about 30 miles. About halfway the Rift begins to be marked by a low and nearly obliterated bluff upon its northeastern wall. This is at first little more than a succession of ridges or hills cut off on the side next to the level plains. These detached ridges finally become connected in a regular line of hills with a steep but deeply dissected slope toward the southwest and long gentle slopes toward the northeast. This ridge is clearly a fault block, and now separates the southeastern arm of Carissa Plain from Elkhorn Plain. It probably originated during some one of the earlier movements along the Rift; in fact, it is reasonable to suppose that it is of the same age as other important scarps which mark the Rift thruout its whole course, and which came into existence as a result of some mighty movement opening the earth for several hundred miles.

Except for one slight bend, the ridge which we have been describing follows a straight course toward the southeast for a distance of nearly 20 miles, finally blending in a much larger mountain-like elevation. This has a height of perhaps 500 feet above the sink at its southern base. Its deeply dissected front is in line with the front of the ridge already described and the two appear to have originated together. The steeper face is deeply sculptured into gullies and sharp ridges, while the back slopes off gently toward the southern end of Elkhorn Plain. Plainly visible along the steep front of the line of hills described are the lesser ridges and hollows produced during the last violent earthquake in this region, probably in 1857. (See plate 21A, B, C.)

A gentle divide separates the southern end of the Carissa Plain from a long narrow sink extending along the Rift line toward the southeast. (Plate 21D, E, F.) This sink includes an area 6 miles long and in places its drainage is fully 3 miles wide. Several depressed alkali flats, covered with water during the wet season, receive the scanty run-off of this dry region. These depressions are several hundred feet wide and are bordered upon opposite sides by quite sharp bluffs, in some places 100 feet high. The phenomena suggest the sinking of long narrow blocks between two walls. This reach of 6 miles between the ranches of Job and Emerson is one of the most interesting areas examined. The larger scarps belong to some ancient disturbance, while the last one, probably dating from 1857, is marked by features comparatively insignificant.

As we ascend the long grade from the sinks just described, to Emerson's place, near Pattiway P.O., the Rift features become smaller and less regular, altho easily followed. (See plate 23A.) At Emerson's the Rift passes thru a sag in the hills and across the head of Bitter Creek. It then rises and crosses a flat-topped hill between this creek and the west fork of Santiago Canyon; and descending to the east fork keeps along the steep mountain slope upon the south until it finally crosses the divide between San Emedio Mountain and Sawmill Mountain. Thru this section the Rift gradually bends toward the east, and in Cuddy Canyon, farther east, it has an east and west direction for a few miles.

The Rift itself is scarcely distinguishable in Bitter Creek and Santiago Canyons, owing to steep slopes and rapid erosion, as well as numerous landslides. Santiago is one of the deepest and narrowest canyons in this portion of the mountains. Its whole southern slope, that traversed by the Rift, has been more or less affected by slides producing many little basins along the edge of the flat-topped divide between the drainage into the San Joaquin Valley and Cuyama River. Huge masses of earth and rock are still moving, as shown by fresh cracks and leaning trees. In one place the edge of the divide has split away in such a manner as to produce long narrow ridges with depressions behind them, closely imitating the real Rift features. Santiago Canyon marks a great fault of earlier times. Soft Tertiary formations are faulted down thousands of feet upon the south side of the canyon, while upon the north appear the steep granitic slopes of the western spur of San Emedio Mountain.

The Rift appears upon the north side of the pass which leads from Santiago Canyon to San Emedio Canyon. Two lines of disturbance are here plainly visible. Going down the west branch of San Emedio Canyon, the Rift zone is plainly traceable, but nowhere does it form important features. Passing to the east fork of the canyon, we continue on the line of the Rift to the divide leading over to Cuddy Valley. (See plate 22A.) Beginning upon the divide, a broad rounded ridge, fully 50 feet high upon its southern side, extends down the slope in a direction a little south of east. Cutting thru the center of this ridge longitudinally is a deep V-shaped depression, as tho a movement later than that which formed the ridge had opened a fissure thru its center. On the sides of the ridge, as well as the slopes of the fissure in it, large pine trees are growing in an undisturbed condition. Continuing down the ridge, we find that in the course of a mile it gives place to an escarpment facing northerly. A valley 4 miles long and 0.5 mile wide lies below the escarpment and contains meadows and a small lake without any outlet. Springs mark the Rift line. The escarpment has been much eroded, but toward its eastern end it has a height of nearly 300 feet and is covered with a growth of pine trees among which are stumps of large dead trees in an undisturbed condition. The valley and the bluff are doubtless the product of the earliest movement in the epoch of which we are treating. The last movement left a comparatively small ridge traceable here and there along the base of the greater.

Continuing on the line of the Rift, we enter and pass for 10 miles down Cuddy Canyon.



A. Looking south-southeast along the Kift toward Onddy Valley from lead of San Emedio Canyon. H. W. F.



B. Old fault-scarp in Eift. East end of Caddy Valley. H.W.F.



A. Looking northwest along the Rift from Emerson's place, near Pattitway. H. W. F.



B. Looking east along the Rift from Gorman Station. The low scarp was probably made in 1857! E. W. F.

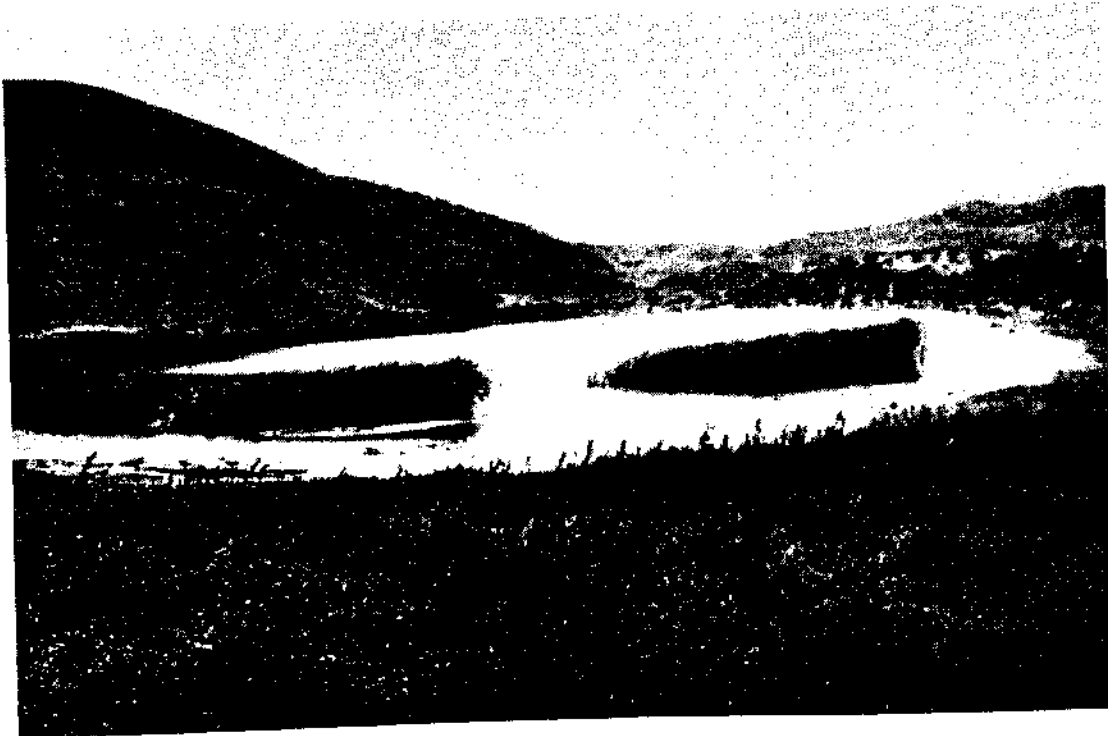

A. Pond and soarp in Rift east of Gorman Station, H. W. P.



B. Lower Lake Elisabeth. In the Rift. H. W. F.



A. Looking southeast along the Eift between Lake Elizabeth and Palmdale. H.W.P.



B. Looking east along the Eift »carp west of Palmdale. H.W.F.

(See plate 22B.) The fissure follows its northern side for several miles and then, bending a little toward the south, crosses the canyon and takes a course for Tejon Pass. The granitic mountains upon the north of the canyon rise with exceedingly steep slopes, the rocks of which have been thoroly shattered. Immense quantities of rock débris have been brought down the gulches, building up in the main canyon a succession of large and steep débris fans. So much débris has been carried down the canyon that it has been blocked at the point where it turns toward old Fort Tejon, and has thus given rise to Castac Lake. The Rift crosses the divide at the gap known as Tejon Pass. Here there are features due to two movements. Descending a few hundred feet, we find ourselves in a long valley, extending about 10 miles in a direction a little south of east. Springs, marshes, and two ponds mark the line of the Rift from Gorman Station easterly. (Plates 23B and 24A.)

At Gorman Station, several miles below Gorman, there is a wonderfully regular ridge forming a marsh. In this vicinity the earthquake of 1857 is reported to have done much damage, shaking down an adobe house and breaking up the road. The little lake upon the divide halfway between Gorman Station and Neenach P.O. is due to débris brought down from the hills upon the south thru which the Rift zone passes. The Rift follows a very regular and straight course, a little south of east, along the mountain slopes south of Antelope Valley. Thru the most of the distance, as far as Palmdale, it occupies a series of valleys shut off by considerable elevations from the open slopes of Antelope Valley. After traversing the northern slopes of Libre and Sawmill Mountains, the Rift crosses the head of Oak Grove Canyon, then another small canyon with branches eastward and westward along the break, and eastward of this a long canyon opening out to the fertile valleys about Lake Elizabeth.

Lake Elizabeth and Lower Lake (plate 24B) are both due to the blocking of the drainage of two valleys extending along the Rift. These valleys lie on the slope of the range toward the desert (Antelope Valley), but their outlet is southward by a narrow canyon thru the heart of the mountains lying between the desert and Santa Clara River. A low escarpment along the southern side of the valley in which Lake Elizabeth lies, and eastward, is replaced by a lofty rounded ridge which appears to be due to some one of the movements along the old fault. For several miles east of the lake (plate 25A) the distinctive and characteristic features of the Rift are not as easily made out, altho the ridge just mentioned is full of springs and exhibits a widespread landslide topography. Toward the eastern end of this ridge small hollows and a low, indistinct escarpment again appear. The ridge separates Leones Valley, a fertile and well-watered district 5 or 6 miles long, from the open Mojave desert on the north.

From Leones Valley to and beyond the point where the Rift zone crosses the Southern Pacific Railway, a constant succession of cienegas is found on the upper side; that is, on the side toward the mountains. Movements have evidently been so often repeated and so intense along the Rift as to grind up the rocks and produce an impervious clayey stratum, bringing to the surface the water percolating downward thru the gravels of the waste slopes. A mile west of Alpine Station on the Southern Pacific Railway, there begins another escarpment with its abrupt face toward the south. This extends to and across the railroad. South of the escarpment the surface has sunk so as to form a basin. (Plates 25B and 26A.) This has been artificially enlarged and used as a reservoir for irrigation about Palmdale. The main escarpment is 40 to 50 feet high in places, and where the railroad crosses it there appear to be two, an older and a younger one. From the summit of the ridge marking the Rift west of Alpine, an extensive view eastward is obtained. The long desert waste plain leading up to the foot of the mountains on the south (San Gabriel Range) exhibits a strikingly interesting feature. It is not continuous across the line of the Rift, but shows a break with the uplift upon the lower side. The amount of displacement appears to be between 200 and 300 feet.



An extended study would be necessary to determine in detail the geology of the Rift from Gorman Station eastward. Near Gorman a dike of basaltic or andesitic lava extends parallel with it for some distance. Granitic rocks often form one side, while soft Tertiary beds of a light or reddish color frequently appear in the raised ridges. Between Palm-dale and Big Rock Creek, low discontinuous ridges, springs, and cienegas point out the line of the Rift, altho there are stretches of several miles at a time where either the original displacement was not great or erosion has removed its effects. Four miles west of Big Rock Creek there is one fine escarpment 0.333 mile long and 40 feet high, facing the mountains on the south. (Plate 27A.) In this section there are indications of at least two movements. (See plate 26B.) The Rift passes just below Big Rock P.O. east of Big Rock; a trail on the northern slope of the mountains and a wagon road on the southern side of the divide follow the Rift continuously to a point near the mouth of Cajon Canyon. On the north side of the mountains (San Gabriel Range) there is no important depression on the Rift between Big Rock Creek and Swartout Valley; nevertheless the comparatively recent movements have been of sufficient magnitude to produce ridges and hollows giving a continuous and easy route for the trail along the slope of the mountains.

Before reaching the divide leading over to Swartout Valley, we encounter some striking features. Near the head of Mescal Canyon a ridge has been split away from the mountain, diverting the little streams from above and making two drainages where one would normally appear. In places this ridge (plate 27B) is as sharp and as perfect as tho formed but yesterday; but the great pine trees, growing upon its top and sides (the altitude here being nearly 7,000 feet), tell us that it must be hundreds of years old. At the head of the canyon the trail leads thru a sharp V-shaped cut where the bare sliding surfaces make it appear as if movement had recently taken place in the Rift. (See plate 28A.)

Passing over a sag in the mountains to Swartout Valley, the Rift is less prominent as a topographic feature, but a line of springs marks its course. Lone Pine Canyon is remarkable for its length and straightness. The Rift passes down its whole length but it is not very prominent. Springs appear at several points, also small cienegas with a slight escarpment below them. At the mouth of Lone Pine Canyon and a little above its junction with the Cajon Canyon (plate 28B) are more interesting features. Two lines of displacement appear here, and between them a long, narrow sunken block with a small lake in its lowest portion. (See plate 29A.)

The line of disturbance now crosses Cajon Canyon, giving rise to broken and sliding cliffs; and then, passing over a spur of the San Bernardino Range, comes out at its foot before reaching Cable Canyon. From this point the Rift continues on southeasterly at or near the junction of the gravel slopes of the San Bernardino Valley and the steep mountain slopes of crystalline rocks. The uniformly straight course which the Rift exhibits in this portion of its length takes it diagonally across the mountains from the northern and desert side of the San Gabriel Range to the southern side of the San Bernardino Range.

The torrential streams emerging from the San Bernardino Range upon the gravel slopes of the broad valley at its base have cut wide flood plains in the ancient gravels which accumulated along the foot of the mountains. The remaining portions of this old slope lying between the stream plains are called mesas. Back of Devore Heights there appears a rounded ridge formed out of the mesa gravels. As we continue toward Cable? Creek, springs and cienegas are found to be numerous just above it. East of Cable? Creek the ridge becomes an escarpment facing the valley, and in places shows a height of about 75 feet. Viewed in profile, this escarpment breaks the uniform slope of the mesa gravels, almost reversing their slope on the upper side. On the west side of Devil Canyon there is a double escarpment in the gravels, both apparently being due to movements along the Rift. (See plate 29B.) Back of the Museupiabe Indian reservation and north of the



A. Sink between 2 soarps of the Rift a mile south of Palmdale, H. W. P.



B. Pond in the Eift 2 milei west of Big Kock Creek, Moja« Desert. H. W. F.

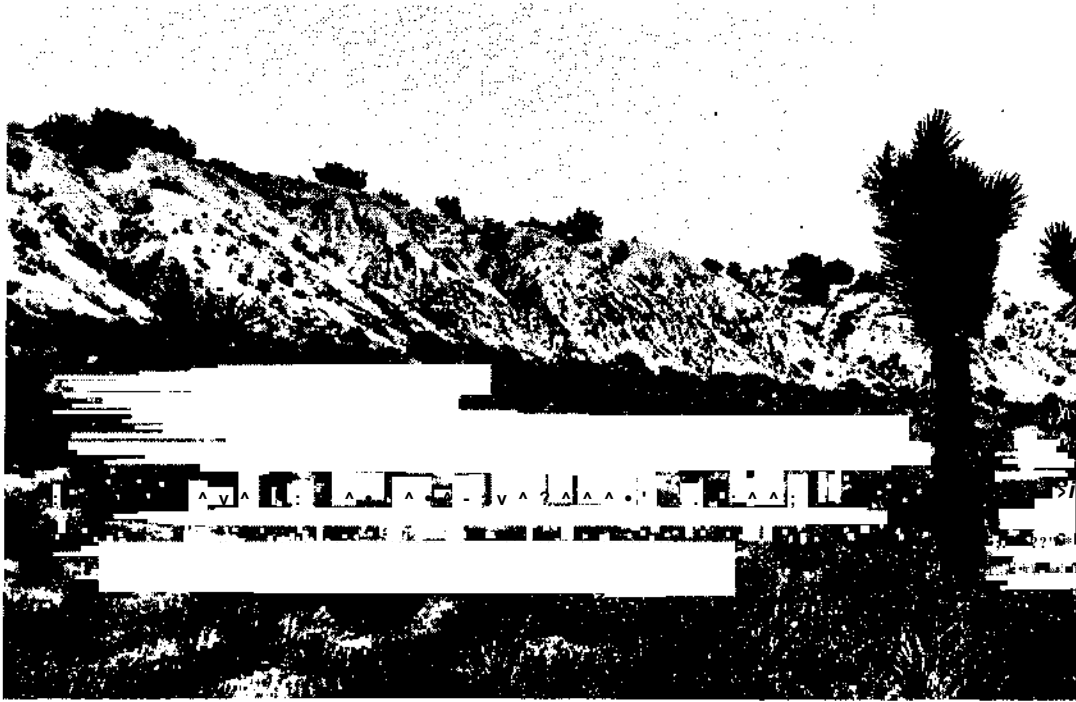

A. Fan-t-scarp in the Eift. Mojave Desert west of Big Eock Oreet, H.W.F.



B. Ridge in the Eift near the head of gwartoat Valley. H.W.F.



A. The lift across the mountain crest west of Swartout Valley. North slope of San Gabriel Range. H. W. F.



B. Looking southeast from lower end of Lone Pine Canyon across lower end of Cajon Canyon. Lake and meadow due to ridge in Eift. H. W. P.



A. Looking west along the Eift from Cajon Pass, showing double scarp. H. W. F.



B. Double fault-scarp in Rift north of Hightod, at base of Ba. Ben-idiuo Ea. g. H. W. P.

Asylum, there is a much dissected fault cliff 200 to 300 feet in height. Plainly traceable in the front of this cliff is a small break, possibly made in 1857. No definite information could be gained as to whether the earth opened here at that time, but reports say the earthquake was very severe, throwing animals from their feet, etc.

East of City Creek begins a huge rounded ridge formed in the mesa gravels, and this can be traced nearly to Plunge Creek. This ridge is 150 feet wide and steeper upon its upper side, where the greatest displacement shown is about 40 feet. The structure and shape of the gravel ridge make it appear likely that faulting and folding were both concerned in its making. Above this ridge and at the highest point where it crosses the mesa, water is obtained in abundance for irrigation at a depth of 18 to 20 feet, while in the mesa below the ridge no water is found at a depth of 200 feet.

The Santa Ana River has cut out a wide stretch of the mesa gravels, and has exposed upon its eastern bank a good section of these gravels. The gravels at their upper edge do not lap over the crystalline rocks but appear faulted down against them. A 0.25 mile below the fault is the mouth of Morton Canyon, the stream issuing thru a long, narrow canyon eroded in the mesa gravels. Morton Canyon emerges from the steep mountains about 2 miles to the southeast and has taken this peculiar course thru the gravels to the Santa Ana River, instead of flowing directly down across them, as do all the other streams. The explanation of the turning to the northwest of this canyon at the point where it meets the gravels is found in the peculiar appearance of the gravel slope when viewed in profile. This, instead of rising with normal slope, becomes steeper toward the upper edge, and then descends abruptly to Morton Canyon. The movement on the Rift has broken and lifted up the gravels to such an extent that the waters of Morton Canyon were diverted and turned down to the Santa Ana River along the upper side of the ridge. Since this displacement took place, they have had time to cut the canyon in which they are now flowing. Southeast of the point where the Rift crosses Mill Creek, the peculiar topographic features which have characterized it for so many miles become very indistinct. It was at first thought that the Rift terminated in this vicinity but closer examination made it clear that such is not the case.

The southern portion of the San Bernardino Range lying between Mill Creek and the Conchilla Desert appears to have undergone great disturbance at a recent date. As a consequence, erosion has been rapid and extensive, and surface features which farther north made the Rift easy to follow have in this region been almost completely obliterated. Potato Canyon extends along the line of the Rift to the southeast of Mill Creek. Its features indicate that the history of the fault is a complex one. The canyon originated thru erosion upon the fault contact between the crystalline rocks of the San Bernardino Range and the older Pleistocene deposits along its base. Following this period of erosion was one in which gravels were again deposited and this was succeeded by the present period in which erosion is active. Potato Canyon is the last of the longitudinal depressions of any size marking the line of the Rift. Between its head and the desert to the southeast the main drainage features pay little attention to the structural conditions, because of the steep grades of the stream channels and consequent rapid erosion. Nevertheless small lateral canyons have been formed along the fault contact of the gravels with the crystalline rocks of the higher portion of the San Bernardino Range, so that from the proper viewpoint the fault line can generally be traced in the topography. The drainage of Potato Canyon is clearly influenced by the fault, for instead of there being one stream course in it, there are two — one upon each side.

A mile southeast of Oak Glen, which is at the head of Potato Canyon, there are large springs which issue upon the line of the fault. Near this point a depression appears upon a gravel ridge, where it meets the crystalline rocks. The depression is in line with the course of the fault, and may with reason be attributed to dislocations similar to those so

clear farther north. Two miles southeast of Oak Glen is Pine Bench, a mesa-like remnant of gravel having an elevation of about 5,000 feet. At the northern edge of this mesa, and upon the line of the fault, there is a regular escarpment facing the higher mountains. It is most reasonable to interpret this as indication of the same displacement referred to previously.

To the east of the San Gorgonio River, the topography as shown upon the San Gorgonio quadrangle gives little indication of the presence of an important fault-line. However, an examination of Potrero Creek shows small transverse canyons and one broad, grassy flat with springs upon the line of the fault. In Stubby Canyon and other small canyons north of Cabazon Station, the fault is finely shown. Here, as at the point where the Santa Ana River issues from the mountains, the older Pleistocene gravels have been faulted down against the crystalline rocks. Rapid erosion of both the Pleistocene deposits and the crystalline rocks has given rise to steep and precipitous slopes in this section, and upon these the fault is clearly shown. The schists and gneisses thru a width of hundreds of feet adjoining the fault have been so crushed by pressure and movement that they quickly crumble upon exposure. Dark clay marks the plane of movement which inclines to the north at an angle of about 80 degrees. Later than the period of main faulting has come an elevation of the range as a whole, giving rise to rapid erosion upon both sides of the line of fracture. Remnants of gravel mesas and mature topographic forms appear in places. A notable example of an area of old topographic features now being destroyed by the modern canyons is shown to the west of Stubby Canyon and 1,000 feet above it.

There are traces here and there of recent displacements along the Rift. These are of the nature of little sags without outlets and low ridges or escarpments not easily explainable as a product of ordinary erosion. These may have arisen as the product of landslides, but the landslides themselves are doubtless related to fault movements. The great debris fans built up along the north side of San Gorgonio Pass indicate rapid removal of a vast amount of rock material from the adjoining slopes of the San Bernardino Range consequent upon recent uplift.

Before investigating this region it was thought that the Rift, if it continued on southeasterly, would be found crossing the San Gorgonio Pass in the neighborhood of Cabazon and skirting the eastern base of the San Jacinto Range; but this proved not to be the case. Instead, it was found to turn more and more easterly and finally to extend parallel with the pass without reaching it. The course of the Rift, then, instead of being in the direction of the Salton Sink, is toward the Conchilla Desert north of Palm Spring Station.

Looking east from a point near the mouth of Stubby Canyon, the gravel mesa thru which the Whitewater River issues from the mountains, appears to be faulted upward, giving rise to a well-defined escarpment facing north toward the crystalline rocks. This northward facing escarpment accords in relative position with the traces of escarpments farther north near Oak Glen, and shows that the latest displacement has been the reverse of the earlier. The last seen of the Rift is in the sides of the Whitewater Canyon, where the gravels are faulted down against the crystallines. East of the Whitewater one enters upon the Conchilla Desert over which has been spread the wash of Mission Creek. For a distance of 6 or 8 miles, and perhaps much more, the bedrock is completely buried by the recent accumulations.

The San Bernardino Range rapidly decreases in height to the southeast of Mission Creek, but appears to be continuous with the desert range lying north of the Salton Basin. The latter range of crystalline rocks appears to be separated from the lowlands of the basin by a more or less continuous line of barren yellow hills formed of soft late Tertiary rocks. Judging from a cursory examination, these yellow hills are separated from the higher mountains behind by a structural break indicated by a series of longitudinal valleys. A prolongation in a northwesterly direction of the supposed fault line indicated by these

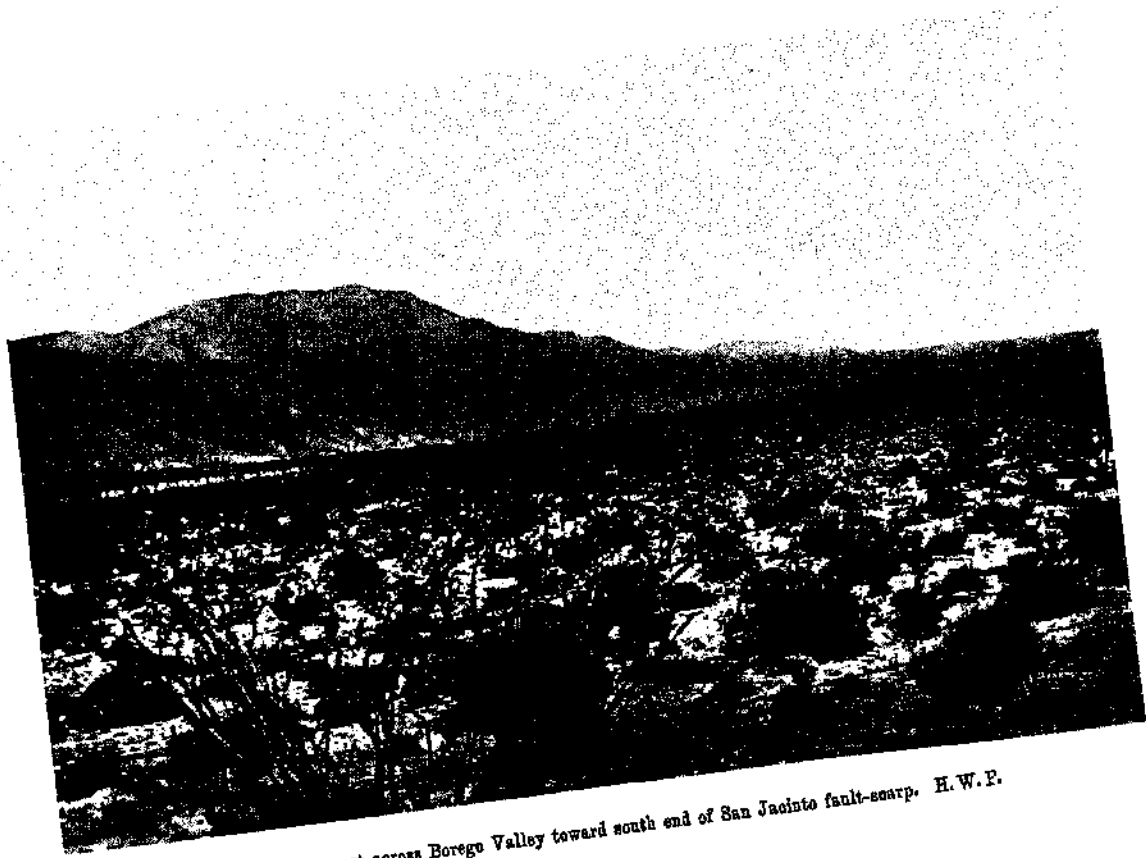

A. Looking east across Borego Valley toward south end of San Jacinto fault-scarp. H.W.F.

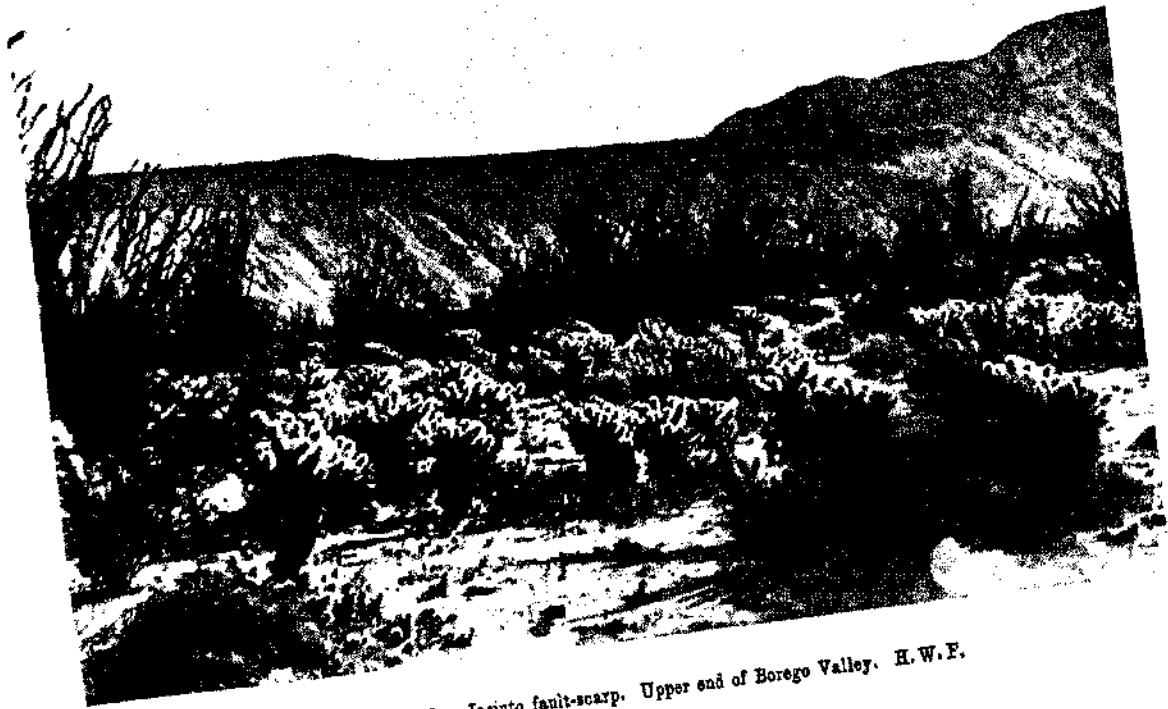

B. A nearer view of the San Jacinto fault-scarp. Upper end of Borego Valley. H.W.F.



valleys would carry it into the San Bernardino Range at the point where Mission Creek emerges upon the wash plain. Continuing still farther northwest, we follow a marked topographic break which leads across the southern slope of San Gorgonio Peak to the head of Mill Creek. It is very probable that the great fault followed so far joins the above fault-line at some point easterly from Palm Spring Station, altho the many miles of gravel-covered desert makes a positive statement impossible with present knowledge.

An examination of the northerly and easterly base of San Jacinto shows conditions opposite to those characterizing the southern slope of the San Bernardino Range. Erosion is generally slow upon the slopes of San Jacinto, while the rapid erosion from the opposite side of San Gorgonio Pass has crowded the stream channels close to the base of the former range. In fact, the base of the San Jacinto Range appears to be deeply buried by the stream deposits. The desert face of San Jacinto has long been free from disturbances. Long, jagged ridges project out into the desert, while the intervening canyons, instead of furnishing material for extensive débris fans, are floored by accumulations characteristic of the desert as a whole.

Toward the southern end of that spur of the San Jacinto Mountains which projects into the Colorado Desert and is known as the Santa Rosa Mountains, the débris fans are larger and remains of gravel deposits appear high up on the sides of the mountains. The only suggestion that a fault traverses the Salton Basin in the direction of the mouth of the Colorado is the presence of mud volcanoes and several small pumiceous eruptions near the center of the basin. These are, however, so far removed from any known fractures in the crust that their evidence is of little value. Besides, it is entirely possible that the mud volcanoes may be due to chemical action in the deeply buried sediments of the Colorado delta.

It may be reasonably assumed, then, from our best knowledge, that the southern end of the great Rift is to be traced for an unknown distance along the base of the mountains bordering the Salton Basin upon the northeast, in all probability gradually dying out.

#### SAN JACINTO FAULT.

The San Jacinto fault (plate 30), with which there has been associated at least one severe earthquake since the region has been known, has a length of at least 75 miles. The course of the fault is northwest and southeast, and it is marked by canyons or steep mountain scarps nearly its whole length. The fault first appears upon the south in the form of a regular mountain wall inclosing the north end of Borego Valley. The latter is a western arm of the Colorado Desert lying between the Santa Rosa Mountains and the main watershed of the Peninsular Range. At the northern end of Borego Valley beds of late Tertiary age appear faulted down upon the southwest side of the mountain wall referred to. The peculiar topographic features of this fault-block ridge, and the presence of gravels along portions of its summit, make it appear of recent origin. Northwest of Borego Valley the canyons entering Coyote Creek have brought down immense quantities of rock débris, a fact which indicates recent disturbance along their headwaters. Terwilliger Valley includes a broad expanse of country of low relief upon the summit of the range between San Jacinto and Borego Valley. A portion of the valley is scarcely drained at present, having apparently undergone some subsidence next to the fault-line which forms the southern face of Mount Thomas.

In a northwesterly direction, the fault can be traced in continuous mountain scarp or canyon until within about 8 miles of the town of San Jacinto. A broad valley intervenes until we get north of the town, when a mountain wall commences again, and extends for many miles in the direction of Colton. Reports state that the San Jacinto earthquake of 1899 was most severe along the line of the fault thus traced. Great masses of rock are

reported to have been thrown down in Palm Canyon, which issues from San Ysidro Mountain. Ten miles southeast of San Jacinto, on the line of the fault, it is said that a considerable area of land sank with formation of open fissures. Upon the Coahuila Indian Reservation, adobe buildings were thrown down and much damage was done in the town of San Jacinto.

The regular mountain wall facing southwest and extending northwest from San Jacinto appears to be older than that toward the southern end of the fault. Mineral springs occur near or on this line, and the marshy area at the point where the San Jacinto River ceases following this fault-scarp and turns toward the southwest suggests very strongly a subsidence.

#### REVIEW OF SALIENT FEATURES.

It will be of advantage briefly to review the salient features of the San Andreas Rift, in the light of the facts presented in the foregoing detailed description of its extent and character, and of other facts to which attention will be directed.

The San Andreas Rift has been traced with three interruptions from a point in Humboldt County, between Point Delgada and Punta Gorda, to the north end of the Colorado Desert, a distance of over 600 miles. These three interruptions are: The stretch between Shelter Cove and the mouth of Alder Creek, where for a distance of about 72 statute miles it traverses the bottom of the Pacific Ocean; the stretch from the vicinity of Fort Ross to Bodega Head, where for 13 miles it is similarly on the ocean bottom; and the stretch from Bolinas Lagoon to Mussel Rock, where it lies beneath the Gulf of the Farallones for about 19 miles. Of these interruptions only the first involves any doubt as to the continuity of the feature, and this doubt is in large measure removed by the evidence cited hereafter as to the position of the trace of the fault of April 18, 1906.

Thruout its extent the Rift presents a variable relation to the major geomorphic features of the region traversed by it. In Humboldt County it lies within the mountainous tract inland from the coast but to the seaward side of the higher land. From Shelter Cove to Alder Creek it lies to the west of a steep, terraced, coastal slope. From Alder Creek to Fort Ross, it finds its expression in a series of rectilinear, sharply incised valleys, the alinement of which converges upon the coast line to the south at a very acute angle. But near Fort Ross the Rift, without deviation of its general trend, crosses the divide to the coastal side of the ridge which separates these valleys from the ocean, and traverses the terraced coastal slope. Beyond Fort Ross it again lies to the west of a steep coastal slope. From Bodega Head to Bolinas Lagoon the Rift is a remarkably pronounced depression, lying between the main coastal slope and the rather high and precipitous easterly side of the Point Reyes Peninsula. About 0.6 of this depression is below sea-level, forming Tomales and Bodega Bays. This defile is one of the most remarkable and interesting phases of the Rift. It has been a line of repeated faulting in past geological time, and evidently separates a well-marked and probably relatively mobile crustal block from the main continental land mass.

South of Mussel Rock the Rift traverses for a few miles a rolling upland, marked by ponds and old scarps, but with no very marked contrast in relief, and then passes into the very marked and rectilinear San Andreas Valley, along the base of the northeast flank of the Santa Cruz Range. From here to the gap at Wright Station it lies along the base of the range at a distance nowhere greater than 2 miles from the crest. Passing thru the gap at Wright, it crosses from the northeast flank of the range to the southwest flank. Similarly passing thru the gap between the Santa Cruz and Gavilan Ranges at Chittenden, it is again found on the northeast flank of the latter. In effecting this last-mentioned change of position relatively to the mountain crests, a distinct deviation in the trend of the Rift is observable (see map No. 5) as if the path of the Rift accommodated itself to

the mass of the mountain blocks. Farther south, near Bitterwater, the Rift leaves the northeast flank of the Gavilan, and lies along the southwest base of a straight ridge of the Mount Hamilton Range. Still farther south in Cholame Valley it follows the northeast base of the ridge which separates Cholame Valley from San Juan Valley. In the Carissa Plain it hugs the southwest flank of the Temblor Range. But the most noticeable reversal of the relative position of the Rift to the adjacent mountain slopes is beyond Tejon Pass. From Tejon Pass to near Cajon Pass, the Rift lies along the steep northerly flank of the San Rafael and San Gabriel Ranges, on the southern edge of Mojave Desert; but at Cajon Pass it passes thru between the San Gabriel and San Bernardino Ranges, and thence easterly lies on the south side of the latter range. Thus from the San Francisco Peninsula to its southern end, so far as the extent of the Rift is at present known, there is a fairly regular and rather remarkable alternation of the relative positions of the Rift and the mountains adjacent to it.

The Rift as a whole, when plotted upon a general map of the state on a scale of about  $\frac{1}{100,000}$  appears as a sensibly even line with marked curvature, convex toward the Pacific. This curvature is for the most part due to change in the course of the Rift between the southern end of Carissa Plain and Tejon Pass. In this segment of its course its trend changes from about S.  $40^{\circ}$  E., along the edge of Carissa Plain to S.  $65^{\circ}$  to  $70^{\circ}$  E., along the southern edge of the Mojave Desert, the change being gradual and distributed over an arc about 40 miles in length. The general curvature is also accentuated by the change in course between Point Arena and Shelter Cove, on the assumption of continuity between these points. If, however, we take the segment of the Rift between Point Arena and the south end of Carissa Plain, the curvature is very much less marked; and its path on the small scale map referred to approximates a straight line. The curvature is distinct, however, and, as in the general case, is convex to the Pacific. The chord of the arc found by stretching a line from the south end of Carissa Plain to the mouth of Alder Creek has a bearing of about N.  $40^{\circ}$  W. and a length of about 360 miles. The point on the arc most distant from this chord is on a normal to the latter thru San Jose, the distance being about 15 miles.

When the Rift is plotted on larger scale maps (see maps Nos. 2, 4, 5, 21, and 23), it becomes apparent that the course of the Rift is not a smooth uniform curve, but is characterized by several minor curvatures in opposing directions. In locating these curves, advantage is taken of the fault-trace, as far as it extends, as a sharp line within the Rift indicating its mean trend at any point on its course. These curvatures are most interesting features on a line of diastrophic movement, where that movement may be, as it was on April 18, 1906, essentially horizontal on a nearly vertical plane or zone.

The most northerly curvature susceptible of measurement is that shown by the segment of the Rift between the mouth of Alder Creek and Fort Ross. The line connecting the two ends of this segment, at the points where it intersects the shore line, is a little more than 43 miles in length, and has a bearing N.  $37^{\circ}$  W. The Rift, as located for this purpose by the fault-trace, lies wholly on the southwest side of this chord. The bearing of the fault-trace at the mouth of Alder Creek, where it converges upon the chord, is N.  $30^{\circ}$  W., and at Fort Ross its bearing is N.  $40^{\circ}$  W. The fault-trace is at its maximum distance from the chord about the middle of this segment, the distance being about 0.75 mile, and here the bearing of the Rift is sensibly the same as that of the chord, N.  $37^{\circ}$  W. Between Fort Ross and Bodega Head, where the Rift passes under the Pacific, there is probably a slight reversal of this curvature; since, if the course of the fault-trace at Fort Ross were continued, even as a straight line, it would pass to the eastward of the point where it actually intersects the neck of the headland. This slight concavity to the southwest probably extends as far as the mouth of Tomales Bay. From Bodega Head south thru Tomales Bay to Bolinas Bay, the course of the Rift as a large geomorphic feature is

practically straight, with a bearing of N. 37° W., for 35 miles; but there are slight curvatures in the fault-trace within the Rift. For example, the fault-trace, in its path thru Tomales Bay, must be slightly convex to the southwest to clear the little headlands on the northeast side of the bay, as it apparently does. There is a similar slight convexity to the southwest between the head of Tomales Bay and Bolinas Bay. The complementary concavity between these two convexities is near the head of Tomales Bay.

Between Mussel Rock and San Andreas dam, the fault-trace has a slight concavity to the southwest. The projection of its course seaward from Mussel Rock would not meet the southward projection of the fault-trace from Bolinas. There can be little question as to the continuity of the fault-trace across the Gulf of the Farallones; and its path on the bottom of the Gulf must, therefore, take the form of a very flat sigmoid curve, with a slight concavity to the southwest in the Bolinas moiety of the submarine segment and a corresponding convexity at the Mussel Rock end. Between San Andreas dam and Chittenden, the fault-trace indicates a pronounced curvature in the general trend of the Rift. The chord between these two points is about 55 miles in length and bears N. 44° W. The fault-trace lies wholly to the southwest of this line, with convexity toward the Pacific. The point on the curve most distant from the chord is about its middle part, the distance being about 2.25 miles. On this segment of the Rift there is locally a rather abrupt reversal of the curve, south of Black Mountain, which is best seen on map No. 22.

Between Chittenden and a point near Priest Valley there is another pronounced curvature in the general course of the Rift, where it passes over to the northeast flank of the Gavilan Range. Here the curvature is concave toward the southwest. The chord is 60 miles long, and bears, as before, N. 44° W., and the Rift lies wholly on the northeast side. The point on it most distant from the chord is near the middle of the segment, and the distance is 2.4 miles. From Priest Valley to the south end of Carissa Plain, the Rift is nearly straight, but with minor curvatures which can not be more particularly defined, owing to the absence of good maps. The general bearing for this segment is about N. 40° W.

The marked curvature between the south end of Carissa Plain and Tejon Pass has already been noted. From the latter place to the north end of the Colorado Desert, beyond which the Rift has not been traced, there are numerous curvatures in the course of the Rift; but since the Rift for this segment is indicated on maps Nos. 6 to 15 on a scale of 1 or 2 miles to the inch, it will be unnecessary to do more than refer to these maps for their characterization. The general course of the Rift in this region is a flat curve concave to the south-southwest.

It thus appears that the Rift, as a whole, has a curved course convex to the Pacific; and that this general curvature is characterized by a succession of slightly curved, rather than straight, segments. The amount of the curvature, as it appears upon the maps, is determined to some slight extent by the character of the projection. But the general conclusion above reached without quantitative expression is independent of the projection adopted for the maps.

A most interesting general feature of the Rift is in relation to the granitic rocks of the Coast Ranges. The granites of the southern Sierra Nevada pass into the Coast Ranges in the vicinity of Tejon Pass, and extend thence in a series of more or less elongated but discrete areas thru the Santa Lucia, Gavilan, and Santa Cruz Ranges, and beyond the Golden Gate to Point Reyes Peninsula and Bodega Head. From the southern end of Carissa Plain to Bodega Head, this granite lies wholly to the southwest of the Rift. At one point in the Rift, however, in Nelson Canyon, Fairbanks has found the granite exposed on the northeast side of an old fault having a downthrow on the southwest. Southward it passes into a region where granitic rocks prevail on both sides of the Rift. The Rift in the Coast Ranges thus appears to serve as a line of demarkation between two

somewhat contrasted geological provinces; one in which granitic rocks are extensive and important features, and the other in which granitic terranes are wanting. This fact further suggests that the two provinces will be found to be contrasted in other respects when the details of the Coast Range geology are better known. The general fact is indicative of relatively greater uplift on the southwest side of the Rift, and consequently deeper denudation, whereby the rocks of the granitic complex have been stripped of their covering and so exposed to view. In that portion of the Coast Ranges south of the Bay of Monterey, the Santa Lucia Range along the coast is much higher than any of the other ranges which intervene between it and the great valley.

In a discussion of the Rift as a geomorphic feature, it becomes a matter of interest to determine the relative importance of diastrophism and erosion in its evolution. There can be no doubt that where the Rift is coincident with pronounced longitudinal valleys, the latter, altho controlled as to orientation by the faulting along the Rift, owe their features in a large measure to erosion. This is true, for example, of the valleys of the Garcia and Gualala Rivers and the San Andreas Valley. It is not so clear, however, as regards the depression between Point Reyes Peninsula and the mainland. It has been pointed out that in past geological time there has been a recurrence of faults with large vertical displacement on this portion of the Rift, dating back to pre-Miocene time and possibly to the Cretaceous; and it may be that here the depression is essentially diastrophic in origin and only modified to a minor degree by erosion; similarly with some of the valleys along the Rift, and extending from it in the Southern Coast Ranges. The Cholame Valley and the valley of Carissa Plain may be essentially diastrophic in origin, modified by erosional degradation on their sides and by aggradation of their bottoms. The depressions which constitute the Rift along the southern margin of Mojave Desert appear to be practically wholly diastrophic, altho somewhat aggraded. Where the Rift hugs the steep northeast flank of the Santa Cruz Range as far as Wright Station, and the similarly steep southwest flank of the same range from Wright to Chittenden, it is difficult to avoid the conclusion that these steep mountain flanks are in reality degraded fault-scarps, and are, therefore, the walls proper of a great asymmetric Rift valley. The same conclusion applies to the steep north flank of the San Rafael and San Gabriel Ranges, on the south side of Mojave Desert. The complete discrimination of effects of diastrophism and erosion in the larger features of the relief associated with the Rift will require many years of patient field work.

With regard to the minor features which characterize the Rift in detail, thruout its extent, the discrimination is less difficult chiefly because the diastrophic effects are of comparatively recent date and their distinctive features are not yet obliterated by the ravages of erosion. These consist chiefly of scarps, low ridges, and sinks or ponds. In many cases it is apparent that both erosion and aggradation are controlled by these minor features, and that the latter tend to become obliterated. These minor scarps, ridges, and sinks are not referable to any single earth-movement, but are referable to a recurrence of movement on the same general line. In the southern Coast Ranges the observations of Fairbanks show that one of these movements was of exceptional importance. By its displacements and disturbances of the surface were effected which dwarf all similar events in historic times. For miles at a stretch the earth, upon one side or the other of the fault line, sank, giving rise to basins and to cliffs 300 to 400 feet high. These features, in the opinion of Fairbanks, who personally examined them, were the result of one movement. This displacement probably occurred not less than 1,000 years ago. It is certainly older than the great trees growing upon the ridges and hollows formed by it. Since then it is probable that numerous displacements of less extent have taken place, but the geomorphic effects of the smaller movements have, in some considerable measure, been effaced. Since the settlement of the state, the strain in the earth's

crust has continued to manifest itself, and several slight movements have been observed by residents of the country. In 1857 there was a movement extending from San Benito County probably as far as San Bernardino Valley. The earthquake caused by this movement was not less severe than that of 1906, but we have unfortunately no measure of the extent or direction of the displacement. In this southern region described by Fairbanks, the displacements, even from the first, do not appear to have been of such a nature as to give rise to a continuous cliff or scarp upon either side of the fault; and this observation is generally true throughout the Rift. In one place the scarp faces southwest, in another northeast. In other places the vertical displacement has been very small and the scarps correspondingly insignificant. In several places, as, for example, at Fort Ross and between Mussel Rock and San Andreas Lake, displacements have occurred on subparallel lines, giving rise to opposing scarps, as if a wedge of ground, perhaps several hundred feet across, had dropt in. In such depressions lie the sinks; but the latter are more commonly formed by a low scarp facing up a slope, or by a ridge of surface compression formed across the path of the drainage from a slope. They have also been formed by landslides, which have shown little tendency to move save under seismic impulse.

It remains to call attention, in a word, to the alinement of the Rift with certain of the larger continental features. The Rift is known from Humboldt County to the north end of the Colorado Desert. As a line of small displacements it has not been traced farther; and in the usage of the term it has been understood as terminating at the point where it eluded field observation. But it is by no means certain that, as a larger feature, it does not extend far to the south. The Colorado Desert and its continuation in the Gulf of California are certainly diastrophic depressions, and may with much plausibility be regarded as a great Rift valley of even greater magnitude than the now famous African prototype first recognized by Suess. This great depression lies between the Peninsula of Lower California and the Mexican Plateau. All three of these features find their counterpart in southern Mexico. The Sierra Madre del Sur is the analogue of the peninsular ridge; it lies on the line of its prolongation, and is similarly constituted geologically. Inside of this range, and between it and the edge of the Mexican Plateau, is a pronounced valley system which is the analogue of the Gulf of California.

On this valley-line lies the depressed region about Salina Cruz, well known to be subject to repeated seismic disturbances. On the same general line lies Chilpancingo, the seat of the recent disastrous Mexican earthquake. Following these great structural lines southward, they take on a more and more latitudinal trend; and beyond Salina Cruz the geological structure indicates that this seismic belt crosses the state of Chiapas and Guatemala, to the Atlantic side of Central America with an east and west trend, and falls into alinement with Jamaica. It thus seems not improbable that the three great earthquakes of California, Chilpancingo, and Jamaica may be on the same seismic line which is known in California as the San Andreas Rift.

## THE EARTH MOVEMENT ON THE FAULT OF APRIL 18, 1906,

### THE FAULT-TRACE.

The successive movements which in the past have given rise to the peculiar geomorphic features of the Rift, either directly or by control of erosion, have with little question been attended in every case by an earthquake of greater or less violence. The earthquake of April 18, 1906, was due to a recurrence of movement along this line. The movement on that day was of the nature of a horizontal displacement on an approximately vertical fault plane or zone, whereby the country on the southwest side was moved to the northwest and the country on the northeast side to the southeast. This displacement was manifested at the surface by the dislocation and offsetting of fences, roads, dams, bridges, railways, tunnels, pipes, and other structures which cross the line of the fault. The surface of the ground was torn and heaved in furrow-like ridges. Where the surface consisted of grass sward, this was usually found to be traversed by a network of rupture lines diagonal in their orientation to the general trend of the fault. Small streams flowing transverse to the line of the fault had their trenches dislocated so that their waters became impounded. These and similar phenomena of disruption constitute the *fault-trace*.

The width of the zone of surface rupturing varied usually from a few feet up to 50 feet or more. Not uncommonly there were auxiliary cracks either branching from the main fault-trace obliquely for a few hundred feet or yards, or lying subparallel to it and not, so far as disturbance of the soil indicated, directly connected with it. Where these auxiliary cracks were features of the fault-trace, the zone of surface disturbance which included them frequently had a width of several hundred feet. The displacement appears thus not always to have been confined to a single line of rupture, but to have been distributed over a zone of varying width. Generally, however, the greater part of the dislocation within this zone was confined to the main line of rupture, usually marked by a narrow ridge of heaved and torn sod.

The amount of the horizontal displacement, as measured on dislocated fences, roads, etc., at numerous points along the fault-trace, was commonly from 8 to 15 feet. In some places it exceeded this and at one place it was as much as 21 feet. Toward the south end of the fault the amount of displacement was notably less and finally became inappreciable. Nearly all attempts at the measurement of the displacement were concerned with horizontal offsets on fences, roads, and other surface structures at the point of their intersection by the principal rupture plane, and ignore for the most part any displacement that may be distributed on either side of this in the zone of movement. The figures thus obtained may, therefore, in general be considered as representing a minimum for the amount of differential movement. In one or two cases, however, when the displacement has been measured on soft ground subject to slumping, and the measured offset is higher than usual, the results may be in excess of the true crustal displacement.

Besides this horizontal displacement of the crust, there was also, particularly in the region north of the Golden Gate, a distinct **uplift** of the country to the southwest of the Rift, relatively to that on the northeast. This differential vertical movement was made

manifest by the appearance of low, abrupt fault-scarps, ranging from less than a foot up to 3 feet. Many of these occurred along the slope of somewhat degraded fault-scarps due to former movements, and served to revivify them. In other cases the new scarps have been developed on slopes where no trace of a previous scarp can be detected. The low scarp which was formed on April 18 is by no means a continuous feature, but appears at a great many places not widely spaced along the fault-trace, extending often for hundreds of yards at a stretch, with intervals where no abrupt scarp can be detected. In the latter places it is probable that the differential vertical movement has been distributed over a zone of some width, underlain by formations in which the deeper seated fracture would be taken up by plastic deformation. The scarp almost invariably faces the northeast, but a few cases have been noted in which a fresh scarp on the fault-trace faced the southwest for a short distance. These will be mentioned more particularly in the detailed descriptions which follow. Associated with the fault-trace, it is quite common to find secondary or induced movements of the soil, particularly on steep slopes. These partake of the nature of landslides, and very commonly exhibit the characteristic landslide scarp. This is usually, however, easy to distinguish from the scarp on the fault proper, or on the auxiliary cracks, since it lacks evidence of horizontal displacement, and the broken sod is not traversed by diagonal, torsional cracks.

The differential displacement of the earth's crust above indicated occurred only on the northern portion of the Rift. South of San Juan, in Benito County, there is no indication along the Rift in the shape of rupture of the soil, or the dislocation of transverse structures, which points to the displacement of the underlying formations. It is not, however, to be certainly inferred from this that there was no deep-seated rupture south of that point. Many earthquakes are known which are referable to sudden slips in the earth's crust for which there is no corresponding rupture at the surface. It is probable that the slip, which is so manifest as a surface rupture to the north of San Juan, was continued as a subsurface movement for many miles south of that point.

North of San Juan the displacement on the fault-trace has been followed practically continuously to a point on the northern coast of California a little beyond Point Arena, a distance of 190 miles. At this point the fault-trace as a continuous feature passes out to sea, and the evidence of displacement is lost. At Shelter Cove, in southern Humboldt County, however, where as previously stated the Rift features appear again, evidence of displacement due to movement on April 18 is also found. The doubt as to whether the Rift in Humboldt County is continuous with that which leaves the coast near Point Arena, of course also applies to the question of the continuity of the rupture on the day of the earthquake. If we assume that the line of rupture is continuous thruout, then its full extent from San Juan to Telegraph Hill is about 270 miles.

Beginning with southern Humboldt County, a somewhat detailed account will now be given of the phenomena of the displacement which occurred on April 18, 1906.

#### HUMBOLDT COUNTY.

We are indebted to the observations of Mr. F. E. Matthes for our knowledge of the facts concerning the portion of the coast from Shelter Cove northward. The low headland north of Shelter Cove, known as Point Delgada, is traversed by several fissures trending roughly parallel with the general sweep of the coast and presenting essentially the same surface appearance as the fault fractures observed in Sonoma and Mendocino Counties. While it has been found impracticable to demonstrate by actual measurement the existence of a horizontal displacement along any of these new fissures — in the absence of fences or other objects of sufficiently defined outline — yet it has seemed warranted to regard them as true fault or shear fractures, to be classed in the same



category with those found farther south, merely on the strength of their superficial resemblance.

The effects of a horizontal shear on thick grass sod in open country, as observed in a number of localities along the zone of faulting in Sonoma and Mendocino Counties, are as follows: On fairly level ground, where conditions are simplest and no vertical movement is evident, the sod is torn and broken into irregular flakes, twisted out of place and often thrust up against or over each other. The surface is thus disturbed over a narrow belt, whose width apparently varies with the magnitude of the displacement. Along the main fault, where the throw amounts to 10 feet or more, a width of 5 or 6 feet is not uncommon; on the secondary fractures, where the throw does not exceed a foot, the belt is generally only a foot wide. Whatever the width of the belt, the sod within it, as well as the unconsolidated material underneath, appears loosened up and not compact. It consequently takes up more space than before it was disturbed, and the surface of the belt is therefore slightly raised above the level of the ground, from an inch to a foot or more, according to the magnitude of the disturbance. Within such a belt there is seldom, if ever, a well-defined, continuous, longitudinal crack, the toughness of the sod precluding a clean shear fracture. Rather, there is a marked predominance of diagonal fractures resulting from tensile stresses.

To sum up, a horizontal displacement produces and may therefore be recognized in grassy country by a fault-trace showing:

1. The disturbance of the sod over a narrow belt.
2. The generally raised surface of this belt.
3. The absence of a single continuous, longitudinal crack.
4. The tearing of the sod along numerous diagonal fractures.
5. The twisting and thrusting of sod flakes against and over each other.

It was mainly by the aid of these criteria that the fault lines in the vicinity of Shelter Cove were determined as fault or shear fractures, distinct from the innumerable cracks due to the settling of earth masses consequent upon the jar of the disturbance. In practically all of these the sod had been ruptured by mere tension, or tension accompanied by more or less vertical shearing. Furthermore, as will presently appear, the location of the fault fractures was in many instances facilitated by their association with the characteristic fault topography observed all along the line.

What appears to be the main fault-trace was first observed in the bottom of Wood Gulch, where it runs immediately along the wagon road for a hundred feet or more. It was thence traced south to its southern terminus on the beach of Shelter Cove, and then north across Humboldt Creek up Telegraph Hill. Subsequently several apparently detached lines of a similar character were discovered in the neighborhood of the main fault, as shown on the sketch map. Beginning at the south end, this line may be traced as follows:

On the beach of Shelter Cove, 100 yards west of the frame hut of Snider (at the mouth of Deadman Gulch), the fault passes thru the bluffs obscured by dislocated masses of dark conglomerates. From the top of the escarpment, however, it is easily traced for some distance down. The approximate contour map of the fault (fig. 10) sufficiently describes the topography here. A notable feature is a small elongated pond on the steep hillside, walled in by a small ridge. Thru this the fault-trace passes longitudinally. Continuing north, the line remains east of the upper valley of Wood Gulch until it joins the wagon road in the bottom. The line is by no means straight, as the bearings on the map indicate. A pronounced angle in its course exists at *A* (fig. 10), and the coincidence in this change of azimuth with the abrupt topographic change at this point is strongly suggestive of a hade to the west. Near the loop in the road at *B* the fault is easily recognized, except where the road has been repaired. The fault-trace here passes thru a

characteristic little gap or saddle (plate 31A), and south of *B* follows closely an old fault line, with a slight upthrow on the west. North of the road the fault-trace follows a ravine for some distance, then passes along the west side of a low ridge, as indicated in the contouring, and finally drops down to Humboldt Creek. Thence it ascends the

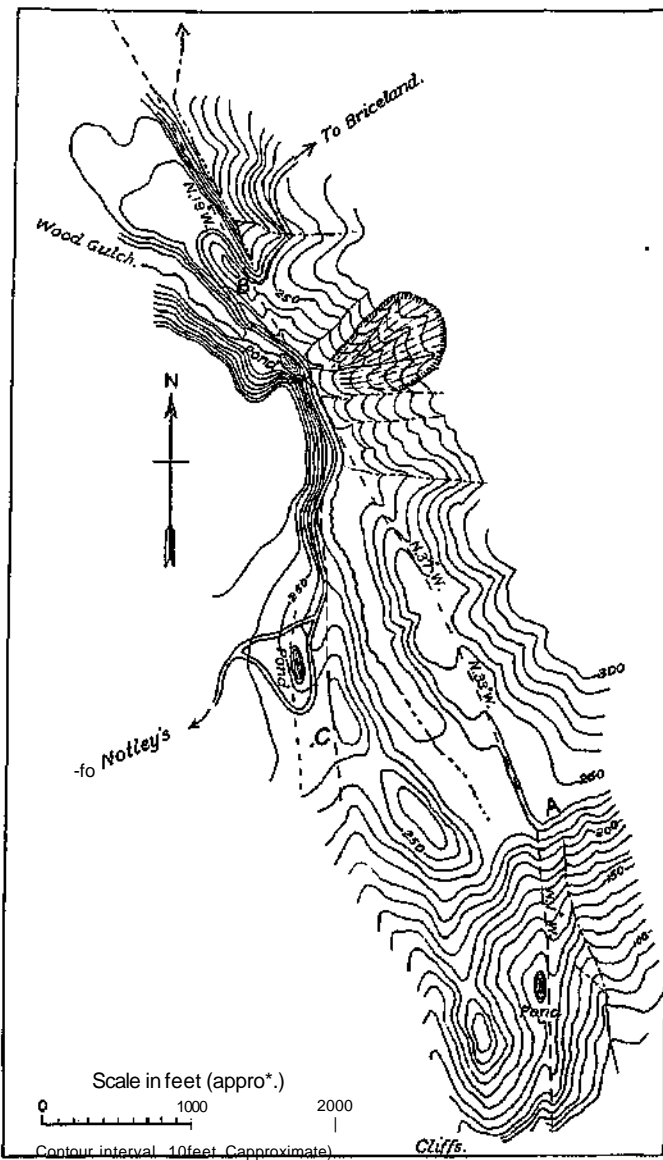

FIG. 10.—Map of country traversed by fault to north of Shelter Cove, Humboldt County.

impression that it past close to King's Peak an ascent of this mountain was made, but without result.

Of the auxiliary cracks, the first one, *C* (see fig. 11), is a less pronounced disturbance than the main fault-trace, passing thru a depression bordered on its east side by a low scarp due to former faulting. A small pond encircled by the road lies on this fault-trace. Its bearing (not measured) is such as to make the line converge toward the main fault-trace and intersect the same in the vicinity of the pond in the bottom of Wood Gulch. The horizontal displacement along this line is probably small, much like that on the

south slope of Telegraph Hill, following for a considerable distance a characteristic fault feature on the steep brushy spurs indicated in plate 31D. Immediately south of the summit of Telegraph Hill the disturbance is the most pronounced, being accompanied apparently by an upthrow on the west side, resulting in a sharp-crested ridge some 4 feet high. It is possible, however, that this ridge is not the result of the recent disturbance, but of a former one, modified into a more acute form by the shaking off of the sod. (See plate 31c.) From the summit of Telegraph Hill a bearing was taken over the entire length of the line down to Shelter Cove: N. 25°W. Projecting the line north from the hill on the azimuth, it appears to head for a number of high mountains of the King's Peak Range, altho no visible traces of the disturbance are found north of Telegraph Hill. Immediately north of its crest is the upper end of a great hopper-like landslide, clean swept for over a thousand feet. The fault-trace is entirely obliterated by this slide. The exact location of the fault north of Telegraph Hill was not ascertained. Under the



A. Fault-soaTp passing thru saddle at head of Wood Gulch, looking south-southeast, F.E.M.

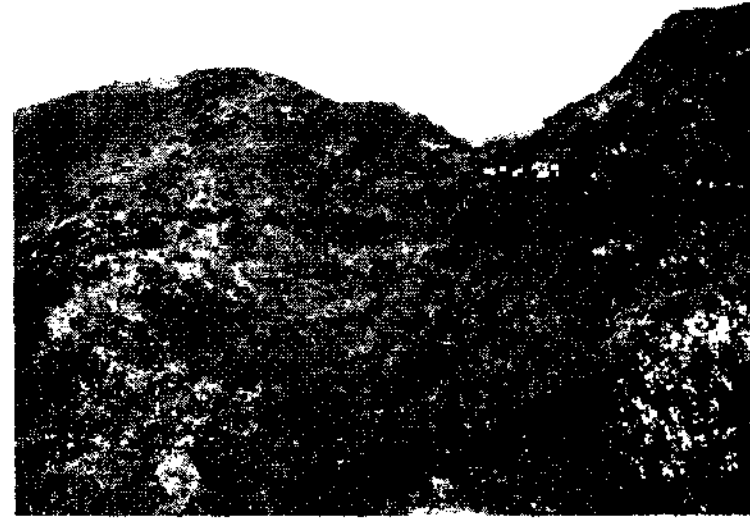

B. Auxiliary fault-trace following old scarp in saddle between Wood Gulch and Humboldt Greek. F. E. M.



C. Looking south-southeast from Telegraph Hill along fault-trace marked by sharp-crested ridge in foreground, with upthrow of  $4\pm$ feet, F,E,M.

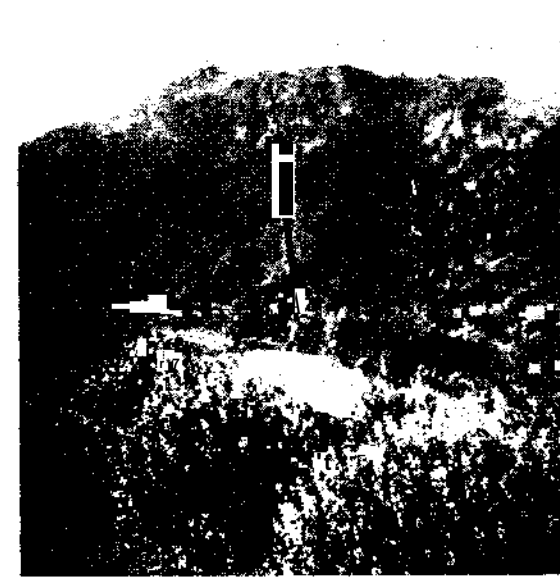

D. Looking north-northwest along main fault marked by small ridges on spurs of Telegraph Hill. P. E. M.

auxiliary fault cracks accompanying the main fault-trace in Sonoma and Mendocino Counties, which it greatly resembles in surface characteristics. Another line of some prominence was discovered near the mouths of Humboldt Creek and Wood Gulch. As fig. 11 indicates, this fault-trace, *D*, follows for some distance along Wood Gulch, then crosses over to the little gorge of Humboldt Creek (plate 31B), which it follows out to its mouth. The divide at *D* has a marked depression along the line of faulting. The fence cross-

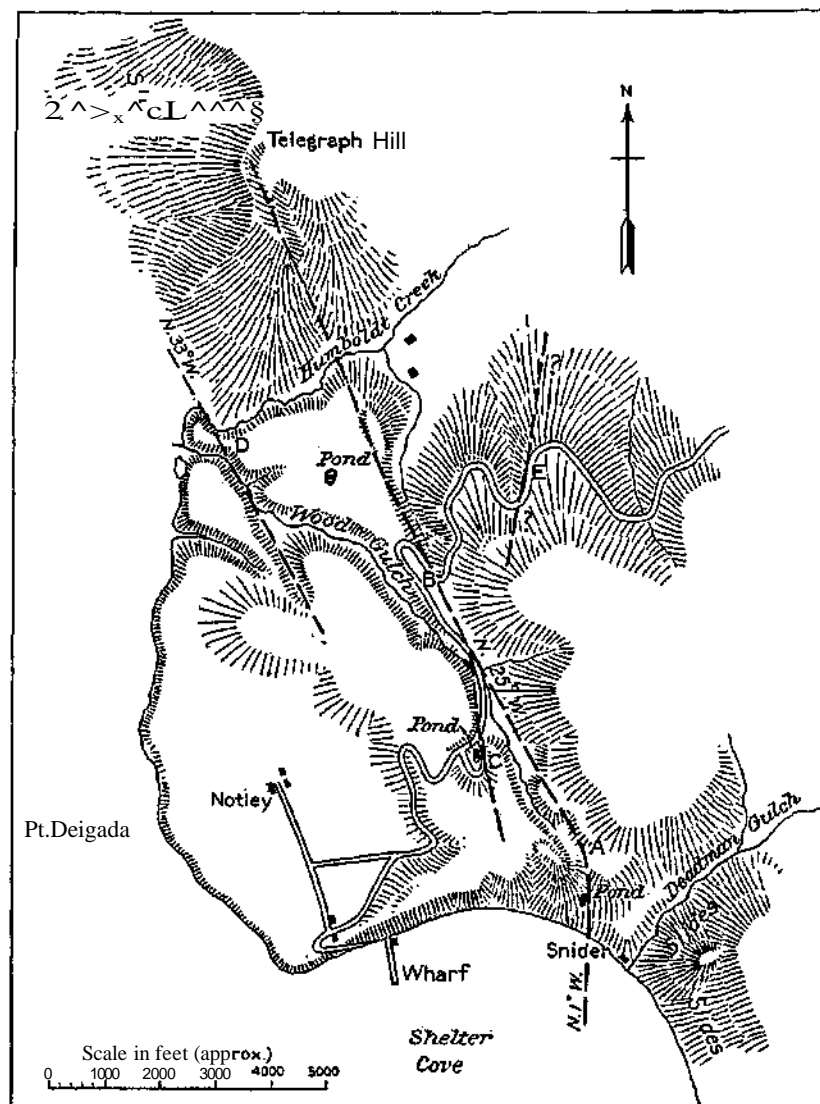

FIG. 11.—Map of country north of Shelter Cove, Humboldt County, showing auxiliary faults in relation to main fault.

ing it shows no signs of horizontal shifting. It was not learned whether or not it has been repaired since the quake. Tracing it to the south up over the grassy hills, it is found to disappear somewhere near the head of the little gulch shown on the map. A third line was found along the wagon road at *E*, following an old fault ridge descending the hillside on a slant. Its probable connection with the *C* line suggests itself.

In search of the north end of the fault, the following itinerary was made: From Telegraph Hill northeast to the old ridge road, to Albert Boots' ranch, thence up King's

Peak and its sister peak to the north; thence to Upper Mattole and Petrolia, *via* the stage road; from Petrolia north across the North Fork of the Mattole River, and along the same over the high terraces to the north branch of the North Fork; also westward over the hills, north of the river, to the summit of the last hill next to the coast, and back along the river; from Petrolia south to the bridge, and up the hills south of the town to the top of the great slide existing there; south to Cummings<sup>5</sup> ranch; and thence across Cooskie Range, between Squaw Creek, Spanish Creek, and Cooskie Creek. It was on the high bald spurs between Cooskie, Randall, and Spanish Creeks, close to the coast, that old Rift topography was for the first time encountered in this district. Several small ponds and ridges are found both on the spurs and close to their bases next to the beach. No sign, however, of a fresh disturbance could be found here.

Finally, an excursion up the coast to Cooskie Creek and then south along the beach to Shelter Cove served to encompass the entire area under investigation. A short side trip was made up the creek flowing from King's Peak, but nothing definite could be learned regarding the location of the fault. South from Hadley's ranch at Big Flat, the precipitous mountain slopes have been destroyed by extensive and high landslides, the dislocated materials of which have frequently advanced out upon the beach in the form of glacier-like tongues. The waves at high tide have since nipt these protruding masses and truncated them at their ends. Many of the slides occurred apparently on the sites of older ones. Their continuity and extent made the discovery of the fault in this neighborhood impracticable. The prevalence of great slides along the coast, back inland, seems to suggest the possibility of the fault curving along the coast, and gradually leaving it south of the Big Flat Ranch. In the belief that this might be the case, and that the fault might continue closely along the coast for some distance, to reënter farther north, a visit was made to the great slide at Cape Fortunus — the most extensive slide along the north coast. No trace of the fault could be discovered here, however. No visit was made to Cape Mendocino nor to Needle Rock, a small promontory south of Shelter Cove. As seen from the cove, this rock has a pronounced saddle suggestive of faulting. Should the fault-trace run thru it, it would have a very strongly curved course, parallel with the coast.

Mr. Matthes' account of the conditions in the vicinity of Shelter Cove may be supplemented by the following note by Professor A. S. Eakle:

Shelter Cove appears as a broad slope spreading out and forming a circular coast line of about 2 miles in length, with a flat plain 6 to 10 feet above the sea. The ocean is constantly wearing away the land and no beach surrounds it. Half a mile from the ocean the land begins to rise in grassy hills which are abruptly cut off from the high mountains behind by a deep canyon. The formation of the cove indicates that it has been broken off from the hills above by a huge landslide, perhaps by a former earthquake. The gorge which separates it from the mainland is on a line with the general coast. On the south side of the cove there are three parallel deep gorges which extend a short distance into the hills; and their continuation over the hills is shown by slight depressions which appear to have been clefts which have become almost filled with the wash of the hills. Along all these lines of weakness fissures were opened and the ground subsided 2 to 3 feet. Cross fissures running from one depression to another are also present. The trend of the main fissures followed the coast, which is northwest-southeast. On the high crests of the Cooskie and King Mountains, which border the coast north of the town, fissures and landslides were reported by ranchers looking for cattle, but this region was not visited. In the range south of the cove landslides were also reported and a photograph of a large one was taken. The rocks of the coast are sandstones and black shales, and the hills and plain of the cove were composed of blue and yellow sandy clay, evidently derived from the decomposition of the shales.

## POINT ARENA TO FORT ROSS.

For the course of the fault and the phenomena of earth movement along it for the stretch of 43 miles between the mouth of Alder Creek and the point on the shore south of Fort Ross where it passes beneath the Pacific, we are again indebted to Mr. F. E. Matthes, who, on behalf of the Commission, made an examination of this territory. In the vicinity of Fort Ross, however, several observers contributed notes as to the phenomena there. For this entire distance, the rupture of the ground and its differential displacement are strongly marked and, except for the occasional local obscuration of the phenomena by brush and timber, are easily traced. The fault-trace enters the shore less than half a mile north of the mouth of Alder Creek and crosses with a course of  $S. 28^{\circ} E.$  the bench-land, or wave-cut terrace, to the banks of the creek about 500 feet in from its mouth (fig. 12). Over the surface of the bench it is marked by characteristic rending and heaving of the sod. At the point where it reaches Alder Creek, the stream bank is rocky and steep, and the course of the crack can be traced down the rocky bluff, tho somewhat obscured by talus. The face of the bluff is shown in plate 32A. On the edge of the bench above the stream cliff (B, fig. 12), there is a rocky knob projecting above the general level. The earth crack passes close to the southwest side of this knob. The hade of the crack on the face of the bluff for a height of about 50 feet is very nearly vertical, but its deviation, if any, from the vertical could not be accurately measured on account of the ragged character of the bluff and the loose rock upon its face. On the northeast side of the rocky knob above referred to, there is evidence of a less well-marked parallel crack, as indicated on the sketch (fig. 12). This also appears on the rocky bluff of the stream cliff, but is less distinct than the main crack.

Southeast of this point, the fault-trace follows the broad stream bed of Alder Creek for nearly a mile, passing beneath a bridge, the wreck of which is shown in plate 32B. In this view, the horizontal offset of the bridge along the fault-line is well shown. It is apparent that this offset is not less than the width of the bridge. On the southwest side of the stream, near the bridge (A, fig. 12), the fault-trace is flanked by peculiar, isolated, rocky knobs similar to that on the northeast side. It is not clear, however, that these rocky knobs have more than an accidental relation to the fault, since they may possibly be residual sea-stacks upon the uplifted wave-cut terrace.

After leaving Alder Creek, the phenomena of surface rupture and displacement were traced thru a series of ranches to the divide passing over to Brush Creek, and down to the vicinity of Manchester. Along nearly this entire distance between Alder Creek and Brush Creek, the line passes thru a series of depressions, swamps, and ponds, the majority of which are not connected with the neighboring streams. Offsets due to the displacement were measured on two fences of Mr. E. E. Fitch's ranch, and the amount of movement was found in each case to be 16 feet, the southwest side having moved relatively toward the northwest. The vertical displacement was, as a rule, quite small; only in a few places did it amount to a foot, presenting a low scarp of that height facing the northeast. To the north of Manchester, an east-west fence line was offset in three places,

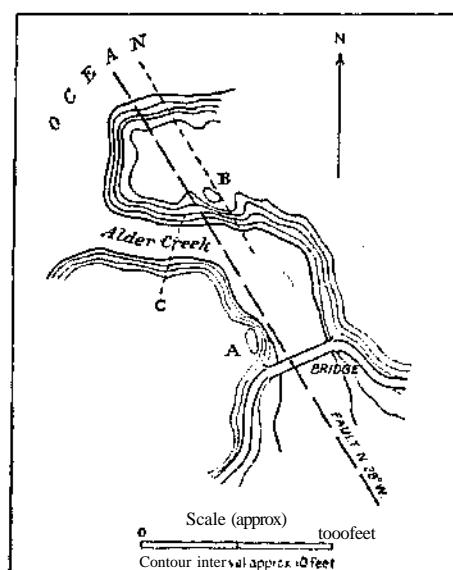

FIG. 12. — Map of mouth of Alder Creek, showing position of fault-trace.

the zone of dislocation being in low, marshy ground. At another place near Manchester, where an east and west fence follows the north side of a wagon road, both fence and road have been offset as shown in plate 32D. In both cases the relative movement on the southwest side was to the northwest. The dairy barn on the ranch of Mr. E. E. Fitch stood astride the line of movement and was demolished by the torsion to which it was subjected. The wreck of the barn is shown in plate 32c. At two places along the stretch between Alder and Brush Creeks the bearing of the fault-trace was measured, the readings being N. 28° W. and N. 30° W.

Southeasterly from Manchester the line of dislocation passes over the dividing ridge between Brush Creek and Garcia River, presenting the same general features. The upthrow is distinctly on the southwest side, but amounts, as a rule, to only a few inches. The horizontal displacement was measured on a line fence south of the divide. The fence is offset in two places. The principal displacement amounts to 13 feet; while on the minor offset, a little to the east, the displacement is 2.5 feet. The relative movement in both offsets is in the same direction, making the northwesterly displacement of the southwest side 15.5 feet. This fence is shown in plate 33A. South of this divide the main fissure passes thru a depression immediately east of a prominent knob projecting south from the divide; while a subordinate fissure traverses featureless hillsides from 100 to 150 feet farther east.

For some distance up the Garcia River from the point where the Rift intersects it, the line of dislocation traverses the flat alluvial bottom land, crossing and recrossing the stream bed. At David Jones' ranch it leaves the bottom and ascends obliquely the side of the valley; and from this point to its head waters it remains on the western side of the valley. Its path is thru a belt of ridges and swamps. Part of the way there are two sets of ridges, the lower or eastern of which coincide with the new line of rupture. Looking along the valley, the more prominent of these ridges appear as notable features of the transverse profile. Opposite Button's ranch, the line is found about 500 feet west of the river, and about 60 feet up on the valley slope. It crosses a road and fence here, producing offsets of 10 feet in both, in the same sense as before noted. At the head of the Garcia River, the fault-trace passes thru a low saddle into the valley of the Little North Fork of the Gualala River.

Down the Little North Fork, the fault-trace follows the axis of the valley on its west side; at a point 1.5 miles north of its junction with the North Fork it runs lengthwise for over 100 yards with the grade of an abandoned logging railroad, tearing the same to pieces. Interesting evidence of the condensation or shortening of the ground in this vicinity is afforded by the buckling of the rails as seen in plate 33D. Here the main line of dislocation lies about 100 feet to the east of the track in the stream bed. The effect of the movement was to shorten the steel rails either by buckling or telescoping after the snapping off of the fish plates. The small trestle in the distance is traversed at an acute angle by an auxiliary line of dislocation and is similarly shortened. At the locality shown in plate 33c, the buckling in the foreground resulted in the breaking of the rails. Similar instances of the shortening of the steel are shown in the distance. Here the main line of dislocation of the earth lies about 50 feet to the east of the track, and parallel with it. Plate 33B is a nearer view of the trestle above referred to. Below this point the fault-trace lies in the stream bed for some distance, crossing the North Fork at a point 200 feet east of its junction with the Little North Fork. Two lines of faulting appear here, both of which caused considerable damage to the railroad track; but the latter having been repaired before the elate of Mr. Matthes' visit, no measurements of offsets were obtainable.

From this point southeasterly, evidence of dislocation along the line of the Rift, in its course up the valley of the South Fork of the Gualala, is obscured by the dense brush to



A. Bocky stream oliff 50 feet high on north side of Alder . Fault vertical on left of knolli auxiliary fault on right of knoll. F.E.M.

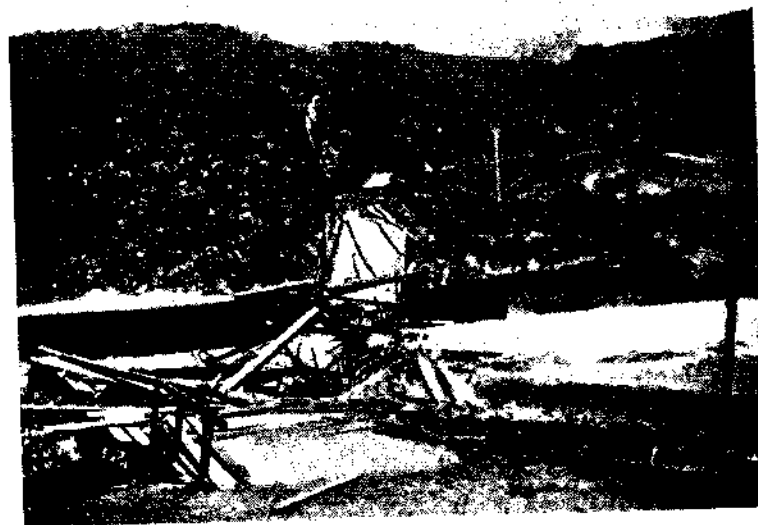

B. Fault passing under bridge over Alder Creek. Bridge displaced not less than its width. F. B. M.



C. Barn of E. E. Fitch, north of Manchester. Astride the fault. F. E. M.



D. East-west fence 0.25 mile north of Manchester offset by fault. Fence and road were formerly straight and have been repaired. Looking east, 7 b. M.



a point east of Stewart's Point. Here the line runs on the lower side of a double series of low ridges, interspaced with elongated swamps, and all trending parallel with the river. (See fig. 13.) Its bearing is N. 33° W.; altho only short sights could be obtained on account of the timber and brush. The bearing noted is nearly in line with the axis of the valley of the South Fork of Gualala River. The amount of dislocation could be estimated only in a rough way from the offsets in the road leading east from Stewart's Point to Lancaster's ranch. A few neglected picket fences gave doubtful results, the alinement of the pickets having been previously disturbed by forest fires, fallen trees, etc. The horizontal movement is distributed over two strong, and one or more dim, lines of

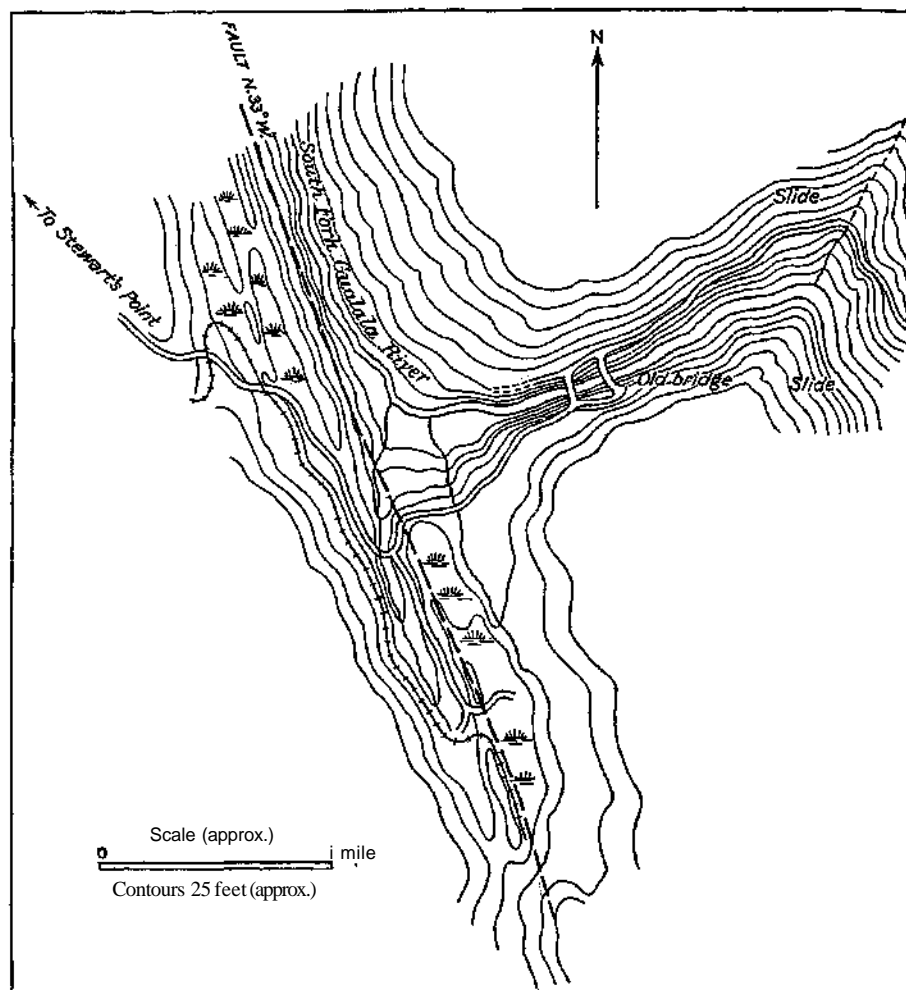

FIG. 13. —Map of valley of South Fork of Gualala River, showing relation of fault-trace to geomorphic features.

faulting, all of them producing offsets ranging from a few inches to several feet. The total displacement apparently did not reach 8 feet. As will be apparent from fig. 13, a logging road runs southeast parallel with the fault for 0.75 mile, and then crosses the same at an abrupt turn. It so happens that the road at this point has been cut thru one of the narrow ridges referred to, the depth of the cut being about 7 feet. The movement on the fault has practically closed the cut, so that it is now barely passable on foot. The bridge over the South Fork of the Gualala River, 3 miles east of Stewart's Point, had

its floor and end panels bent and the tension rods in the last two panels were buckled and twisted.

The upthrow on the fault east of Stewart's Point is on the west side; but farther up stream, where the fault runs along the steep west side of the valley below Casey's ranch, the upthrow is apparently on the east side. The foot trail from Casey's ranch to the river follows a marked longitudinal depression in the steep slope for 100 feet, and it is along the abrupt west side of the small ridge flanking the hollow (see fig. 14) that the fault-trace is located. The upthrow measures fully 2 feet, while the height of the ridge above the hollow varies from a few feet to more than 10 feet. The depression pitches to the north and is drained by a tiny brook. The fault-trace happens to coincide with the latter at a point where the trail crosses the watercourse over a rough wooden bridge. The horizontal movement along the fault practically destroyed the bridge. No measure of the displacement could be obtained here, but the indications are such as to warrant the belief that it did not amount to 15 feet, and that probably some of the horizontal shear had been distributed over minor lines of displacement higher up the slope, and marked by landslides. These landslides above the depression in which the

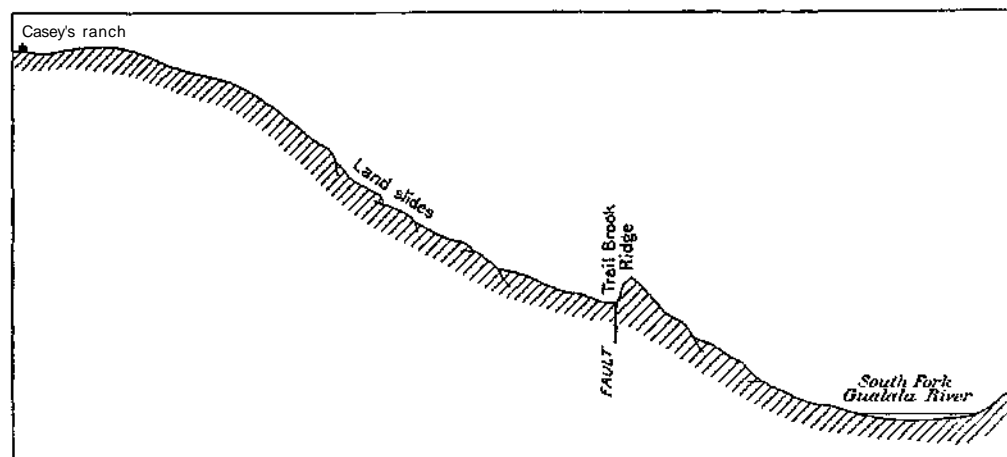

FIG. 14.—Profile of southwest side of South Fork of Gualala River, showing relation of fault to geomorphic features.

fault-trace lies are an important factor in the interpretation of the phenomena. It is easily possible that the scarp looking southwesterly over the depression referred to does not represent the real movement on the fault plane, but is a landslide effect. In any event, the proximity of the landslide weakens very much any judgment that might be formed, implying a reversal of the vertical movement which normally prevails along the line of the fault.

From Casey's ranch southeast, detailed observations were found to be impracticable owing to the dense tangle of brush and fallen timber. The ridge between the upper stretch of the river and the coast is crossed by the fault-trace through a swampy saddle above Plantation House, and the fault-trace traverses the swamp. Plantation House stands practically on the line of disturbance, about midway in a zone 270 feet wide traversed by six roughly parallel lines of rupture. The general bearing of the principal line was found to be N. 38° W. Southward the main fault passes through a series of swampy hollows along an abandoned road, now impassable because of the cracks through it. The line was traced south for 2 miles, its general appearance being found to remain the same throughout. There is a marked upthrow along its west side, not exceeding a foot at any place. Where

it crosses the stage road at the Plantation House, the vertical displacement on the main fault measured 6 inches; that on the secondary lines did not exceed an inch.

At Buttermore's ranch, about a mile east of Timber Cove, the displacement is distributed over three fissures, the principal one running 30 feet west of the dwelling. It intersects three fences, all of which show offsets of about 8 feet. The original crookedness of the fences and the repairs made since the earthquake make the accurate determination of the displacement impossible. The fault-trace was followed for some distance south and north from the ranch thru the forest, and found to follow the swampy depressions most of the way with low scarps or ridges to the west. The ranch and its fields lie for the most part in a broad swampy saddle. The upthrow in this neighborhood is on the west side, not exceeding 15 inches anywhere.

#### FORT ROSS.

North and south of Fort Ross, the phenomena of displacement are well displayed, both on the open-terraced coastal slope and in the timber. The rupture follows for the most part a single well-defined line in the path of the old Rift, coinciding in many places with ancient scarps and the slopes of low ridges. (See plates 35A and 36D.) The fault-trace is commonly marked by a ridge of heaved sod with diagonal cracks as illustrated in plates 35B and 36B. New scarps occur as shown in plates 36c, and 38A, B, as well as accentuations of old scarps. There are, however, several subparallel cracks. Two of these, having each a length of about 150 feet, lie to the west of the main line at a point 1,250 yards northwest of Doda's ranch-house, one 50 and the other 100 feet distant from the main crack and disposed *en échelon*. Within 300 yards to the southeast of this are two short cracks still closer to the main one, and springing from it, at about 450 yards northwest of Doda's ranch-house, is a parallel crack 440 feet in length and 60 feet from the main line. In this case the scarp appears upon the auxiliary crack, and not upon the main line of rupture. Between the short discontinuous crack and the main line is a swampy depression. On the southeast side of the ravine, southeast of Doda's house, the main crack is paralleled by two subordinate cracks, one on each side. That on the southwest side is about 250 feet long and 50 feet from the main line. It has a low scarp facing northeast, but not so pronounced as that on the main line of rupture. The crack on the northeast side of the main line has a length of about 1,125 feet and converges upon the latter toward the northeast. At its northwest end it is 190 feet from the main crack and at its southeast end only 50 feet distant. It has a low, discontinuous scarp facing northeast.

In a distance of 7,250 feet measured along the line of the fault, there are twelve stretches of scarp ranging in length from 125 feet to 1,000 feet, counted both on the main and on the auxiliary cracks and aggregating 3,000 feet in length. Of these eight face northeast and four southwest. The eight scarps facing northeast aggregate 2,250 feet in length, while the four facing southwest aggregate 750 feet. Two of the southwesterly facing scarps, however, aggregating 375 feet in length, are on the descent to the ravine southeast of Doda's house, where there is considerable sliding of the ground, and they may possibly be accounted for as secondary features due to landslides. The other two scarps facing the southwest are unexplained. They are abnormal and are so exceptional that they scarcely weaken the general conclusion that the vertical component of the movement on the fault was upward on the southwest side. The amount of this vertical movement in the vicinity of Fort Ross probably does not exceed 3 feet. In the first hasty examination of the ground, it appeared as if the amount of vertical movement might have been as much as 4 feet. This impression was due to the fact that in places preëxisting scarps were closely followed by the fault-trace, and a sufficiently careful discrimination was not made between the proportion of the scarp due to the new displacement, and that due to

earlier movements. A review of the facts indicates that the addition to the height of the old scarps and the total elevation of the new ones rarely, if at all, exceeded 3 feet. In general it was less than 2 feet.

The distribution of the line of faulting for a typical stretch of the Rift near Fort Ross,

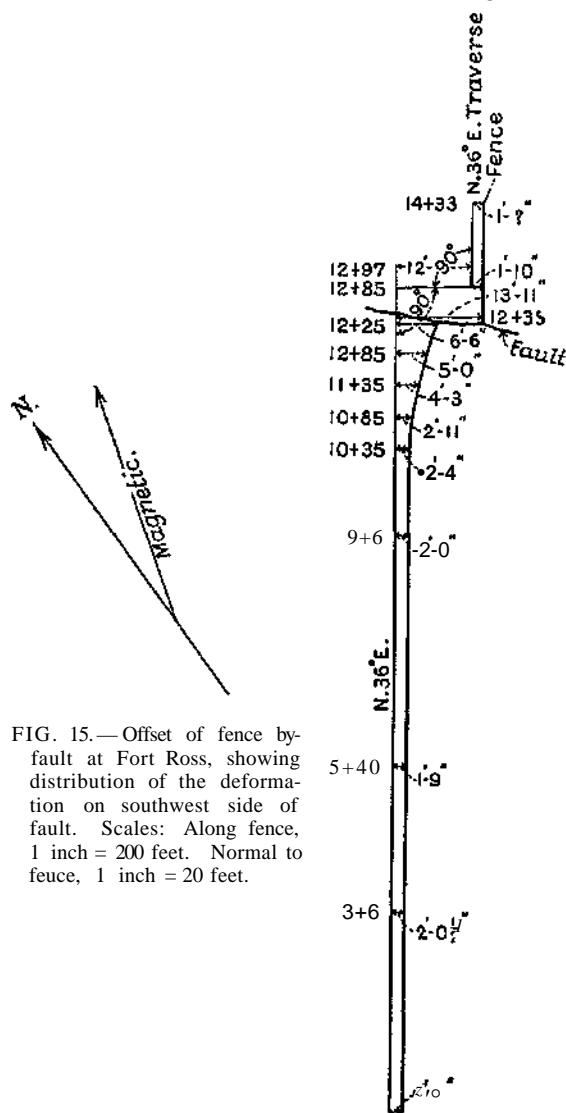

FIG. 15.—Offset of fence by fault at Fort Ross, showing distribution of the deformation on southwest side of fault. Scales: Along fence, 1 inch = 200 feet. Normal to fence, 1 inch = 20 feet.

the auxiliary cracks, the disposition of the scarps upon these, and the relation of the whole to the old Rift features, are well shown on map No. 3 by Mr. F. E. Matthes. The horizontal displacement is also indicated on the map, but this needs more detailed statement.

On the line of the fault, about 300 yards northwest of the road from Sea View to Fort Ross, a steel water-pipe was dislocated by the earth movement, and found to be offset 8 feet, the southwest portion having moved northwesterly. This of course affords only a minimum measure of the relative movement. Where the road just mentioned intersects the fault-trace, both the road and the bordering fences were offset about 7.5 feet, with a slight sag on the northeast side. The zone of shearing here was from 10 to 20 feet wide. A wagon road on the Call ranch, south of the one above referred to, was offset 12 feet 3 inches, the line of dislocation being marked by an open fissure in the soil a few feet deep, and several short diagonal cracks, as shown in plate 36c. Another offset fence is shown in plate 36A, the displacement being here 8 feet at the fault-trace. The effects of the earth movement in the timber to the south of this are well shown in plate 34A. Several large trees standing on the fault line were split or torn asunder. The offset of the south line fence of the Call ranch was carefully surveyed by Mr. E. S. Larsen, and the

results of his survey are shown in fig. 15. The bearing of the fence is N. 36° E. He reports that for the first 1,000 feet from the southwest end of the fence the greatest error in alinement was about 1 inch, and that practically there was no deformation in this stretch. In the next 125 feet going northeast there was found a deviation from this alinement of 4 inches to the southeast. In the next 50 feet the deviation in the same direction was 7 inches more. In the next 140 feet the deviation in the same direction was 3 feet 7 inches more. Then came the fault-trace with an abrupt displacement of the fence of 7 feet 5.1 inches. Northeast of the fault-trace the fence retained its line very well. In 100 feet it was out only 1 inch. Beyond this it enters the timber and its course is somewhat influenced by the larger trees, but maintains its line within a few inches. These measurements give a total horizontal displacement of 12 feet distrib-



A. Fault-trace in redwood forest near Fort Ross. J. N. L.



B. Dislocation of fence near Fort Boss. J. N. L.



A. Accentuation of old scarp by new fault 1.5 miles north of Fort Ross. J. N. L.



B. Fault-trace on grass-covered slope near Fort Ross. E. L. H.

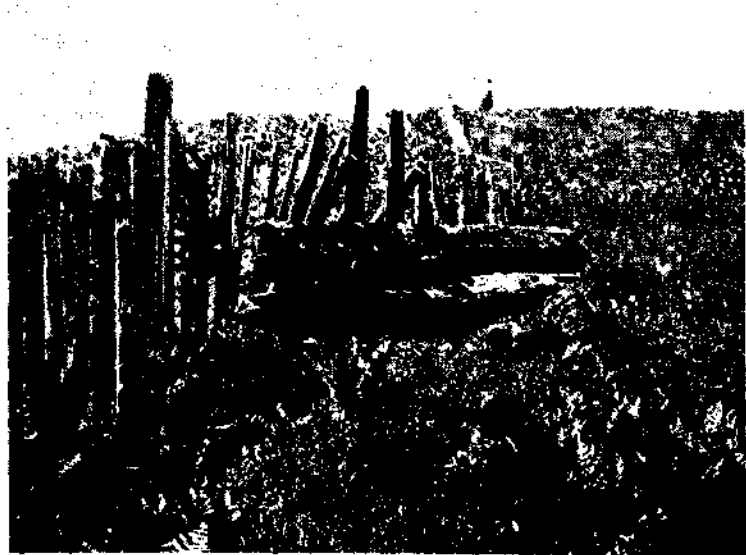

A. Offset of 8 feet on fence a mile east of Fort Boss. R. S. H.



B. Fault-trace and dislocated fence near Fort Boss. B. S. H.



C. Roadway offset 12 feet. New fault-scarp 3 feet high, facing northeast. Above Fort Boss. F. E. M.



D. Accentuation of old fault-scarp by new fault. Near Fort Boas. F. E. M.



A. Offset of stream trench by the fault and ponding of water by the fault-soarp. Doda's ranch, a mile southeast of Fort Boss. A. O. L.



B. The fault-trace a mile northwest of Bolin's Lagoon, looking southwest! Illustrates the ridge phase. G. K. G.



uted over a zone 415 feet in width. Another fence farther southeast on Doda's ranch, having a bearing of N. 36° E., was offset on the fault-line 15 feet; the southwest side, as usual, having moved relatively to the northwest. This fence is shown in plate 34B. One of the most interesting effects of the displacement due to the fault is that seen where the latter intersects a small stream at Doda's ranch-house. The stream flows transversely to the line of the fault, and has a trench across the terrace about 5 feet deep. On the lower or southwest side of the fault, the stream trench has been moved northwesterly about 12 feet, so as to bring a fault-scarp across the entire width of the upper part of the trench and impound its waters in the form of a pool. The result is shown in plate 37A and also on Mr. Matthes' map of the Rift at this place (map No. 3). The impounding of the waters on the line of the fault is interesting evidence of the absence of any open crack.

#### BODEGA HEAD TO TOMALES BAY.

The location of the fault across the neck of land which connects Bodega Head with the mainland was determined by Prof. J. N. LeConte. He reports that on the south side of this neck the main earthquake fissure was found passing about 50 yards west of a house occupied by Mr. Johnson. It could be traced as a multitude of small cracks in the swampy land from the bay to the road, then as a well-defined fissure up the small depression west of the house for 200 yards to where it disappeared in the sand dunes. No trace of it could be detected in the sand dunes, which reach from this point entirely across the peninsula. Only one fence crosses the fissure and this had been repaired so that no measurement of the displacement was possible. The movement was evidently northward on the west side, as was shown by the direction in which the bushes were bent. The vertical movement was about 18 inches, the uplift being on the west side. The sand spit which closes the bay on the south was examined for evidence of movement, but nothing could be detected in the drifting sand.

At the mouth of Tomales Bay there are two points projecting westward from the east shore, and both of these, according to the observations of Prof. R. S. Hoiway, are crossed by the fault-trace. The first is a long, flat sand-spit extending well across the mouth of the Bay just south of Dillon's. The line of the fault was still visible in the sand on June 11, 1906, in spite of the obliterating action of the wind and the recent rains. The line lies near the base of the spit and has a northwest-southeast course. On each side of the crack are crater-like depressions, some of them being double or overlapping. Mr. Keegan, the owner of Dillon's Beach, reported that these craterlets were numerous and distinct. In some instances a great deal of sand and water had been ejected. Others are reported on the southwest side of the fault-trace, from which the belt containing them extends some 70 feet. The craterlets vary in size up to 6 feet in diameter and it is reported that on the day after the earthquake the water which stood in them could not be bottomed by a fishing pole.

About 1.5 miles southeast of this spit is a promontory about 100 feet high projecting into the bay. Some 400 yards from the end of this promontory on top of the ridge is a line of depression with two or three small ponds. The main fault fissure here divides into two cracks, one each side of this depression, which is about 150 feet in width. Standing on this ridge, the line of the fault can be traced at low tide for nearly 1.5 miles across the bottom of the bay to the sand-spit to the northwest, its course in general being parallel to the axis of Tomales Bay. (See plate 38c.) The horizontal displacement where the fault crosses the promontory is about 8 feet, as determined by the line of tall grass at the edge of the little ponds, the westerly side having shifted to the northwest.

## TOMALES BAY TO BOLINAS LAGOON.

BY G. K. GILBERT.

*The Fault-trace.* — The trace traverses the zone of the Rift. Its general course is N. 35° W. and it nowhere departs more than a few hundred feet from the straight line connecting its extreme points. For considerable distances it is a single line of rupture; elsewhere it is divided into parts which separate and reunite; and in yet other portions it is composed of unconnected parts arranged *en échelon*. There are no vertical sections exhibiting hade, but the relation of the trace to sloping surfaces indicates that the fault-plane is approximately vertical.

For considerably more than half its length the surface expression is a ridge from 3 to 10 feet wide and ranging from a few inches to about 1.5 feet high. (See plates 37B and 40A.) The ground constituting the ridge is in fragments, loosely aggregated, so that there are considerable voids. Where pasture lands are crossed the turf is torn into blocks, and these, in conjunction with the cracks which separate them, make up a pattern. This pattern is always irregular and sometimes gives no evidence of system, but usually its lines have a dominant direction, traversing the ridge obliquely, the northern ends of the cracks pointing toward the eastern boundary of the ridge, and the southern ends toward the western boundary. The cracks have resulted from stresses connected with the horizontal faulting, in which the southwest block moved northwest with reference to the northeast block. (See plate 39.)

In other places, and usually for short distances, the surface expression is a shallow trench (plates 40B and 46B), with ragged vertical sides from 2 to 5 or 6 feet apart, and occupied by loosely aggregated fragments of the ground, the pattern of the fragments and interstices being similar to that observed in the case of the ridges. This phase suggests that just below the surface the fault may be somewhat open, so that there has been an opportunity for fragments to drop into it.

In a third phase the ground is not notably elevated nor depressed but is traversed by a system of cracks obscurely parallel one to another and making an angle of about 45° with the general direction of the trace. Their orientation is such that they run nearly north and south. The cracks do not meet, but leave the intervening strips of ground in full connection with the undisturbed ground outside the trace. This phase occurs chiefly in wet alluvium.

There are a few spots where for short distances the surface expression is a simple straight fracture along which horizontal motion took place.

In the detailed descriptions which follow, the first three phases described above will be spoken of as the *ridge phase*, the *trench phase*, and the *echelon phase*.

The most southerly observation of the fault-trace was on the spit separating Bolinas Lagoon from the ocean. Near the west end of the spit its surface is covered by small dunes, and among these the trace was seen in its echelon phase. After a lapse of nine months the drifting of the sand had obliterated most of the cracks, but a few were still visible. Inside the spit lie a number of islands, the largest of which, Pepper Island, has a nucleus of sand (the vestige of an ancient spit), but superficially consists mainly of a fine tidal deposit. In the earlier field excursions the fault-trace was here overlooked by the echelon cracks by which it is represented being mistaken for secondary cracks, but at the present time (spring of 1907) it is easily traced, even from a distance, because the vegetation on the two sides of it has acquired different colors. Unfortunately the camera does not discriminate these colors. (Plate 41A.) The echelon phase here dominates, but the ground east of the trace is depressed about a foot, and this depression has so changed the relation of certain plants to the tides that they now find the conditions of life unfavorable and are dying out. This matter will be considered more fully in another connection.



A. Fault-trace in old depression marked by scarp  $3 \pm$  feet high, with auxiliary scarp above Doda's ranch, a mile southeast of Fort Boss. Looking southwest. F. E. M.

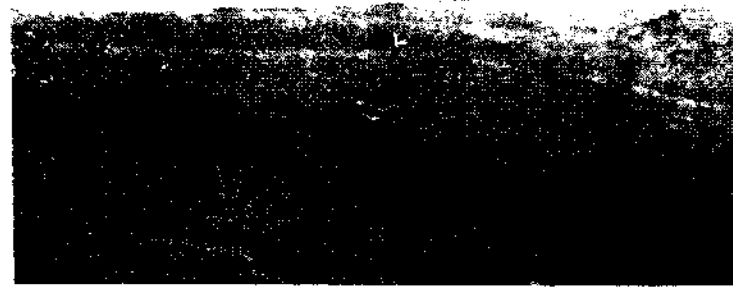

B. Fault-trace marked by scarp  $3 \pm$  feet high on west side, Southeast of Fort Eosg, looking southwest. F. E. M.



C. Fault-trace extending from cliff in foreground across tidal flats of Tomales Bay, near its mouth. E. S. H.



D. Fault-trace between garden and house, Skinner's ranch, near Olema. Before earthquake center lines of path and steps were coincident | afterwards offset was 15 feet 9 inches.

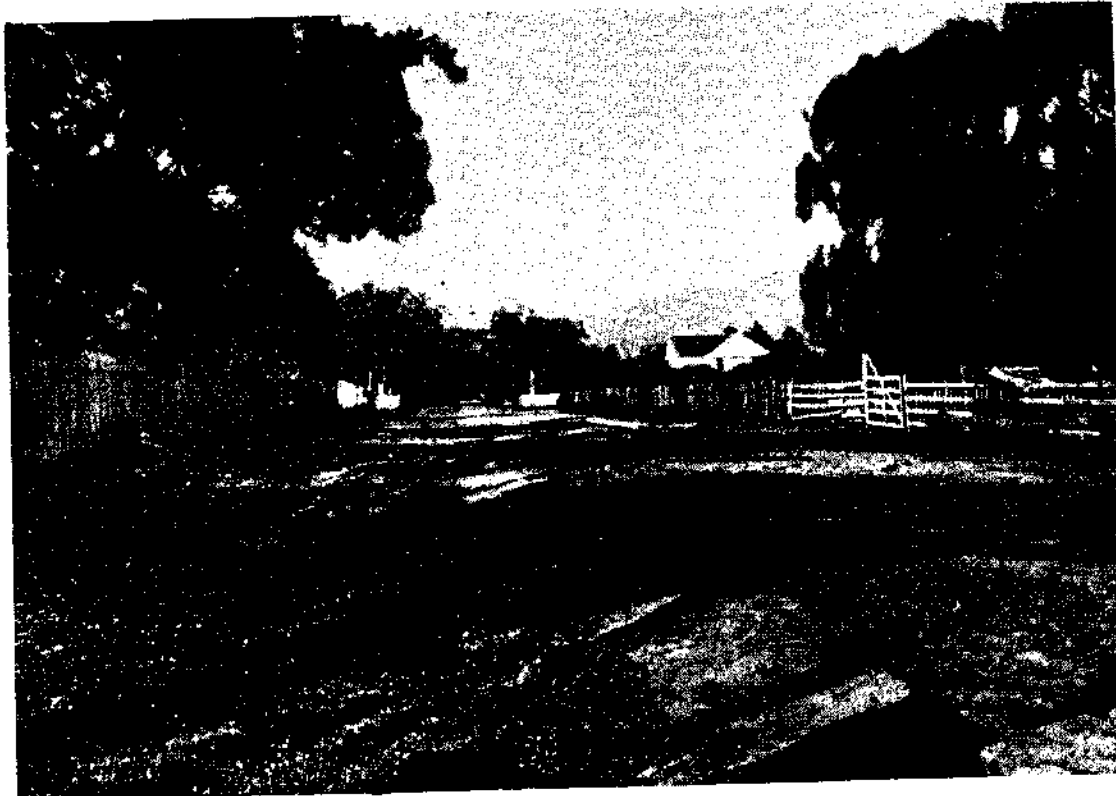

A. Branch of fault-trace in north part of Bolinas. Looking north-northwest. Illustrates diagonal cracks. & K. G.



B. Branch of fault-trace, near Buaditti's ranch. Looking tooth. Illaatrates diageaai cracks. G. K. G.



A. Fault-trace a mile northwest of Olema. Looking northwest. Illustrates ridge phase. G. K. G.



B. The fault-trace west of Olema. Looking southeast. Illustrates the trench phase. G. K. G.

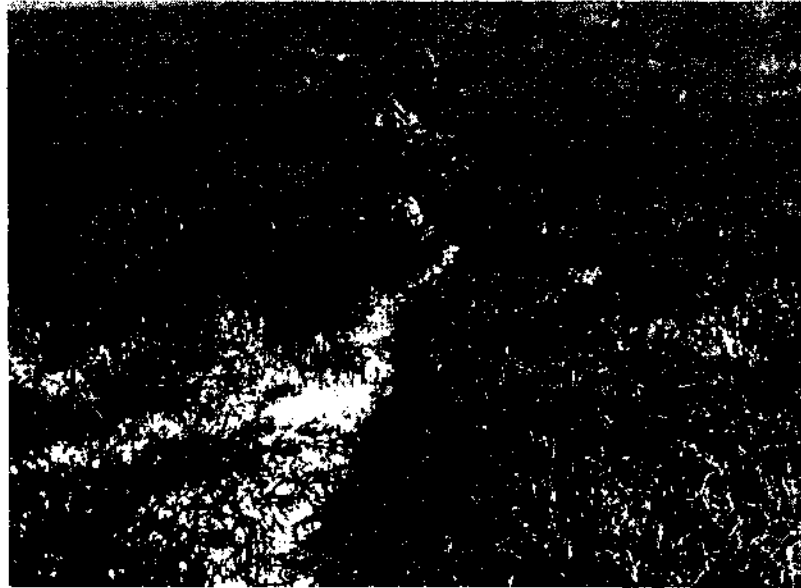

A. Looking southeast OE Pepper Island. In the foreground the fault-trace is central. It trends toward the distant +. Q. K. Gh



B. Looking north from hill west of Woodville. From trailings (Strain ranch) a large rift ridge rans northwest between 2 lanlt-sags. The western sag is followed by Pine Gulch Creek. Fault-trace raas from right of pond in foreground to left of buildings and follows gag for a mile, gradually crossing it, Q. K. G.

In the XI. S. Geological Survey map of this region the islands are not represented. In fig. 28 they are represented as they appear at half-tide, or, more strictly, the parts shown are those covered by vegetation. This figure also shows the corresponding part of the delta of Pine Gulch Creek. After crossing Pepper Island and a smaller island immediately adjacent, the fault-trace disappears under the water of the lagoon and it was next seen on the mainland of the southwest shore near the head of the lagoon. In the interval it probably crosses the delta of Pine Gulch Creek between the lines of high and low tide, but this tract was not examined until after the floods of March, 1907, which overspread it with alluvium. A disconnected group of cracks opening in the alluvial plain of the creek about 400 yards to the west (plate 39A) probably marked the position of a divergent branch of the fault. This line of disturbance crossed the creek and road near the bridge in the northern settlement of Bolinas, trending approximately north and south and fading out in both directions.

The trend of the fault-trace on Pepper Island is about N. 34° W., and if continued would bring the trace to the shore at the head of the lagoon, but its actual position on the mainland is farther west, indicating that there is either a swerving, or an offset in the part not seen. Near the shore the fault occasioned a number of landslides which obstructed the road until removed; and beyond the confusion occasioned by the landslides the trace consists of a number of subparallel cracks occupying a belt several yards in width. There is also a nearly parallel branch of the trace in a fault-sag lying a little farther west, but this could be followed only a short distance, and has since been largely obliterated by plowing. Mr. Nunes, who cultivated this sag, states that it once contained a pond or marsh, and this he had drained, but the water stood there again after the earthquake, showing that the earthquake had caused a depression of the bottom of the sag.

The diffused cracks on the main line soon gather into a narrow belt and descend into a narrow sag, containing the barn and other farm buildings of the Steele place. After following the sag for a short distance, the trace gradually rises on its eastern wall, crosses obliquely an intervening ridge, and enters a parallel sag toward the east. In this sag, which also is narrow, the trace intersects one of the roads leading from Bolinas to Woodville and immediately begins to ascend the narrow ridge bounding the sag on the east. Crossing this ridge obliquely, it skirts for 0.25 mile the western border of the much broader sag in which the water of Pine Gulch Creek gathers before it enters the canyon from which it is named. This wall it descends obliquely, and, just before reaching the bottom of the sag, intersects and offsets a line of eucalyptus trees marking a property and township boundary. The ridge phase dominates in this region (plate 37B), and near the line of eucalyptus trees the trace itself has a small offset to the west. (See fig. 18.)

Now for nearly half a mile the trace follows a valley-bottom, being divided on the way between two or three branches. The ridge phase obtains, but there are several places in flat alluvial ground where the ordinary group of cracks is replaced by a single crack with clean shear. On Mr. Strain's place two fences were crossed which afforded measurement of horizontal displacement. Beyond them the fault-trace becomes once more single, and, after passing a group of very small ridges and sags, begins to climb the eastern wall of a larger sag, which here contains Pine Gulch Creek. (See plate 41B.) Along its line there soon develop a small sag and ridge constituting a sort of shelf or notch on the wall of the deeper sag (plate 42A), and in this small sag are several ponds. (Plates 10A, 54A, and 55A.) The sag first rises for a distance and then gradually descends. The fault-trace exhibits here in alternation the ridge and trench phases, and at many points there is an apparent vertical displacement with throw of 1 or 2 feet toward the northeast. (Plates 10B and 48B.) Near Bondiotti's house the individuality of the sag is lost, and the fault-trace swerves somewhat to the east. A parallel trace develops west of it, and the two come together near Beisler's place. Northwest of Beisler's is a relatively high fault

ridge, and the fault-trace climbs the end of this, following a narrow groove or ascending sag. Here also are ponds. Farther on it passes to the east of the ridge crest and follows a side-hill sag similar to the one followed 2 miles farther south, except that it is on the eastern instead of the western face of the fault ridge. (Plates 8B and 9A.) The apparent vertical displacement is here in the opposite sense, the west side having apparently dropt, but the throw is small.

Thence the trace descends obliquely to the canyon of Olema Creek 150 feet below. Where the creek makes a decided bend toward the west the trace crosses it twice, and then follows near its west bank for several miles. Not far from the second crossing it is

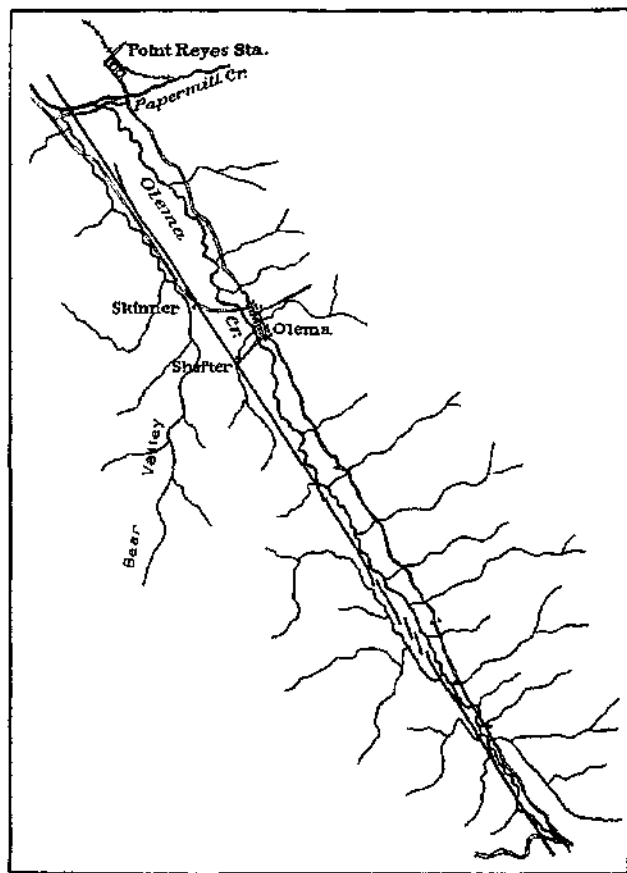

FIG. 1(i). — Map of fault-trace from Papormill Creek southward. Scale, 1:112,500.

subject to a series of offsets, giving to the trace as a whole the same echelon character commonly observed in the arrangement of its details. It is noteworthy that where these offsets occur the trace swerves somewhat toward the right and the new line begins at the left, so that the arrangement is essentially a magnification of the arrangement of cracks in what I have called the echelon phase of the fault-trace. There is this difference, however, that the elements of the larger echelon make a comparatively small angle with the general course of the trace. At several points in this part of its course the trace follows steep slopes from which the timber has not been cleared. On these slopes, which face the northeast, its course sometimes coincides with that of a very narrow sag occupied by marshy ground. Elsewhere it crosses an upland to which a series of sags gives gentle undulation and here it touches or passes near a number of ponds. (Plate 43.) The route

of the fault-trace in this region and thence north to Papermill Creek is shown by fig. 16, a compilation based on data from several sources, including a few original measurements.

A mile south of the village of Olema the trace enters a sag which is followed continuously for nearly 3 miles. At first the sag is narrow and is attached to the northeast slope of a ridge, but approaching the Shafter place the ridge crest sinks and a broad sag replaces it in the line of trend. (Plate 42B.) In following the eastern edge of this sag from the Shafter place to Papermill Creek the fault-trace also follows the western base of a line of hills. The hills are peculiar in that their western, or more strictly southwestern, base, being determined by faulting, is nearly straight (plate 42B); while their northeastern base, modified by the erosive action of Olema Creek, is scalloped. In this region the ridge; phase of the fault-trace dominates, being occasionally replaced by the trench phase. (See





A. Sag followed by fault-trace a mile north of Strain ranch, Looking southeast. Trace, concealed by bushes, runs near ponds, G.K. Q.



B. Looking southeast from point near Shafter's ranch, Okma. Fault-trace follows base of hill and includes water-filled depression. Q. K. Q.



A. Fault-trace 1.5 miles south of Olema. Looking southeast. Trace touches both ponds, being best seen between them. G. K. G.



B. Looking southeast across hill-top a mile south of Olema. Shallow sag gives hill double crest and makes a pond basin. The fault-trace, both in foreground and beyond, is divided into several branches. G. K. &



A. Fault-trace a mile northwest of Olema. Looking northwest. G. K. Q.



B. Fault-trace a mile northwest of Olema. Looking southeast. G. E. G.



A. Fault-trace on Papermill delta. Looking northwest. The water lanes are largely at right of main line of fracture. O. I. G.

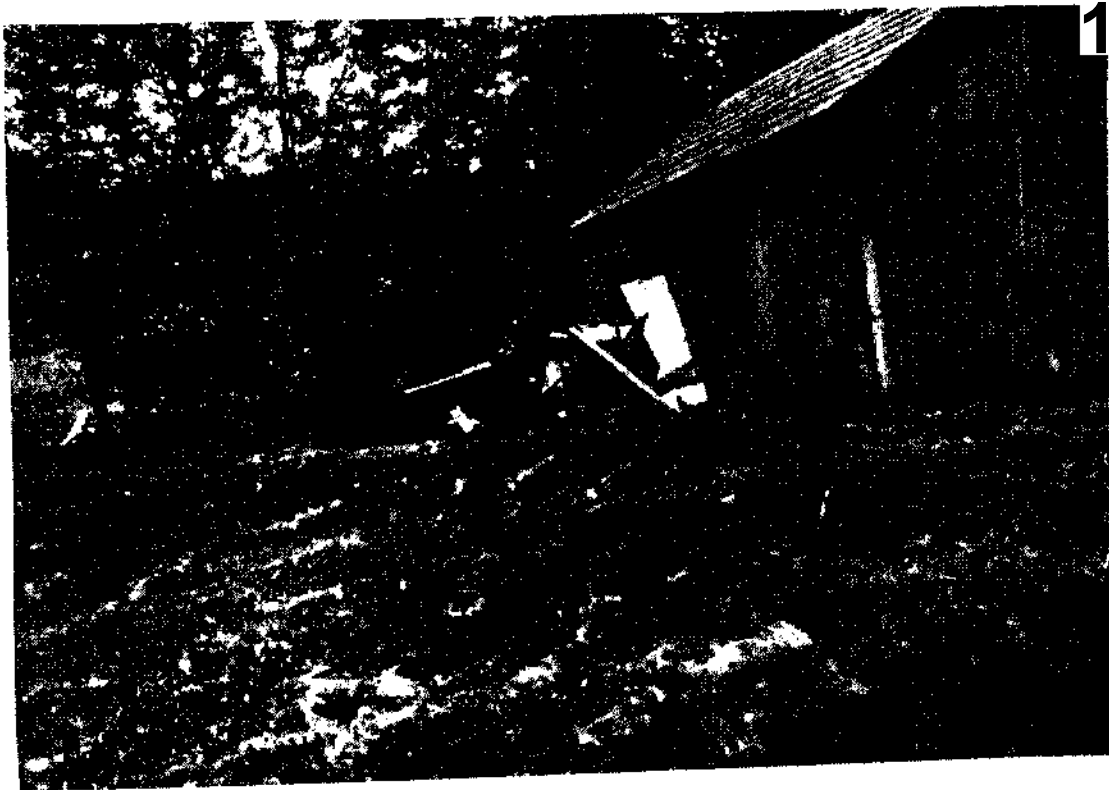

B. Branch of fault-trace in "Second Vrtflr." at Inverness. Looking south-west. G. K. G.

plate 44.) A few minor branches were seen on the east side. The pool or lane of water shown in plate 42B is about 2 feet deep. Mr. Shafter states that the ground here was dry and under cultivation before the earthquake. Shortly after the shock he noticed that the current of a creek close by was reversed.

Just south of the head of Tomales Bay, Papermill Creek enters the valley from the east, crosses to the southwest side of the valley and then turns toward the bay, in which it has built a delta. The delta occupies the whole width of the bay and is about 3 miles long, the greater part of it being submerged at high tide. At the head of the delta Olema Creek joins Papermill, bringing its tribute of detritus; and on the opposite side of the valley Papermill Creek receives the water of Bear Valley Creek, which brings no sediment but filters for some distance through a marsh. At the head of the delta a road crosses the valley, resting partly on the delta and partly on the marsh just mentioned, and furnished with an embankment to lift it above the floods. Just before reaching this road the fault-trace enters the marsh, where it quickly expands to a width of nearly 60 feet and exhibits the trench phase. Not only was the road offset by the fault and earthquake, but the portion between the walls of the trench was dropt down, the embankment sinking into the soft earth until nearly flush with the marsh. In restoring the embankment about 3.5 feet of earth were added. Close to the road Papermill Creek was crost, with offsetting of banks, and thence the fault was continued thru the delta to its end. (See plate 46A.) Its course is nearly straight and of such direction as to pass just outside the end of the cape near Millerton, the bearing being N. 35° W. At several points it is margined on the northeast by a lane of water (plate 45A), indicating that a narrow tract on that side is deprest, but no evidence was found of a general depression of land on one side of the fault as in Bolinas Lagoon. The echelon phase is dominant; the ridge phase does not appear. The trench phase obtains for short distances, and is combined for larger distances with the echelon. Where the trench phase occurs, it coincides with the zone of abundant cracks and is thus distinguished from the sag holding the lane of water.

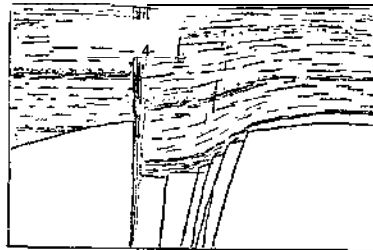

FIG. 17. Hypothetic section of fault under Papermill Delta.

The general relation of the sag to the fault-trace is shown in fig. 17. It occurs only on the northeast side, but is so persistent that, from a commanding position, the fault can be traced out by means of the water lanes. The depression will probably average more than 50 feet wide, but it eludes measurement because it fades out gradually on the side away from the fault. The greatest noted depth is 17 inches, but the average is probably less than a foot. In attempting to interpret this feature I assume that beneath the smooth plane of the delta, and buried by its soft deposits, is a variegated topography of the rift type; and the hypothesis I advance is that the new-made sag on the delta plain is the surface echo of a fault-sag of the buried topography which was made deeper by the event of April, 1906. It has already been pointed out (page 67) that the sags of the Rift which were touched by the new fault were apparently deepened; and if the true explanation of the delta-sag has been suggested, we have in that feature an indication that the deepening was not only apparent but real.

At the northern edge of the Inverness settlement is an outlying or branch fault-trace about half a mile long. (Plates 45B and 47A.) Starting in what is called the "Second Valley," it ascends to a mesa and then descends toward the "Third Valley," its course being about N. 20° W. In crossing the upland it is associated with a fault-sag and there exhibits the trench phase with horizontal displacement of 2.5 feet. Two shorter traces, trending northward, occur on the slope between the "First Mesa" and the "Second Valley."

*Measurements of throw.* — At all points where horizontal throw was observed, the ground at the southwest, as compared to ground at the northeast, moved northwestward. On Pepper Island in Bolinas Lagoon a horizontal displacement was shown by jogs in the directions of the south coast, of the limit of vegetation at the north, and of a well-defined change of flora dependent on the relation of land levels to tide. These various features are too indefinite to give value to measurement of offset, but the general indication is that the amount of throw is somewhat larger on the island than at the nearest points of measurement on the mainland.

A mile northwest of the head of Bolinas Lagoon the fault-trace intersects a row of eucalyptus trees which had been set to mark a property line, the boundary between lands of S. S. Southworth and S. McCurdy. The row is now both dislocated and curved, and as there is reason to believe it was originally alined with care, its present condition shows the distortion of the ground at the time of the earthquake. The fault-trace, as shown by the accompanying map (fig. 18), is here offset *en Echelon*, and the row of trees is not only crost by one section of the trace but approached by the other. At the point of crossing the dislocation is 10 feet. On the northwest side of the fault are six trees, all in line. On the southwest side are a dozen or more trees of which all but three are in line. If the line of either straight division be projected across the fault (broken lines in map) it passes 13.5 feet to the left of the line of the other division. The three trees nearest the

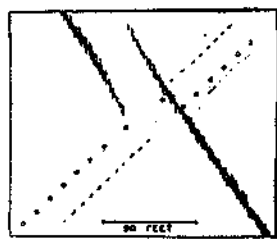

FIG. 18.—Dislocated row of eucalyptus trees.

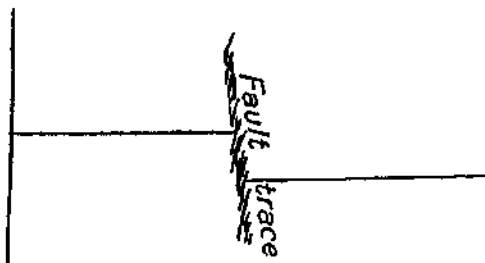

FIG. 19.—Dislocated fence on farm of S. S. Southworth, near Woodville.

fault on the southwest side follow a gently curving line. The indication is that about three-fourths of the whole displacement occurred on the main plane of the fracture, and the remainder was diffused thru the ground adjoining on the southwest. A closely related condition exists at the southern limit of the same field, where the fault-trace intersects a fence at right angles. The offset is 7 feet 8 inches, and this is accompanied by a change of direction. (Fig. 19.) Unfortunately the fence is too short to indicate in full the changes of the ground, but the suggestion is that in addition to the visible offset, there is a diffused shear affecting the ground southwest of the fault so that the entire displacement is greater than the amount shown by the offset. Assuming the fence to have been originally straight, the total displacement here was more than 12 feet.

On Mr. E. R. Strain's place, west of Woodville, measurements are afforded by the disturbance of two fences. The more southerly (fig. 20) is crost by two visible branches of the fault, and there is probably more or less diffused shear in the intervening ground. The fence, said by Mr. Strain to have been originally straight, has now two straight portions, *AB* and *CD*, and the distance from *AB* to *E*, on the line of *CD* produced, is 15 feet. The second fence, standing a little farther north, is intersected by one visible fault-trace, the continuation of the trace which crosses the first fence near *B*. On this line the fence is broken and offset 8.5 feet. The remnant of fence to the southwest is straight, but swerves in approaching the fault-trace, as indicated in fig. 21 and in plate 49A. The total displacement of the straight portions of the fence is about 11 feet.

The four localities last mentioned are included in the space of 0.5 mile. Their several indications of the total displacement, in the order of position from south to north, are 12 +, 13.5, 15, and 11 feet. The range of these determinations is 4 feet and their approximate mean 13 feet. At each locality the indicated displacement consists partly of definite faulting along one or two planes of fracture, and partly of diffused shear, distributed thru a belt of rock, or at least a belt of soil. At each locality the indicated shear is all in one direction. At each locality the measurement depends for its authority on the assumption that the disturbed fence or row of trees was originally straight.

Eight miles farther north, at Mr. W. D. Skinner's place, near Olema, the entire fault is apparently concentrated in a single narrow zone, and the several measurements made are in close accord. The fence south of his barn (fig. 22) was offset 15.5 feet. The barn, beneath which the fault-trace past, remained attached to the foundation on the southwest side, but was broken from it on the northwest side and dragged 16 feet. A path in the garden, originally opposite steps leading to the porch, was offset 15 feet. (Plate 38D.) A row of raspberry bushes in the garden was offset 14.5 feet. The mean of these four measurements is 15.25 feet, and their range is 1.5 feet.

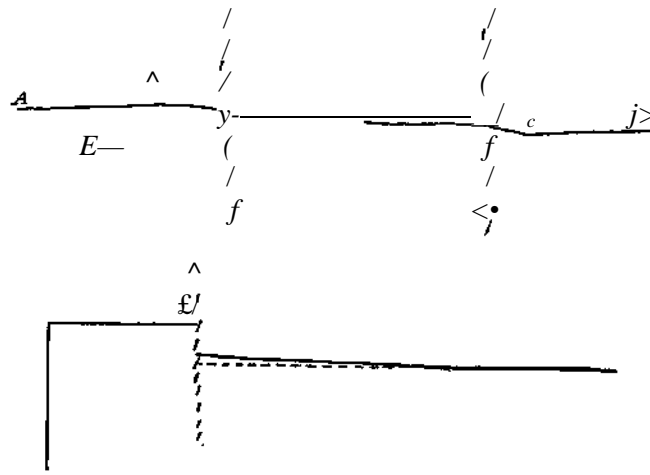

FIGS. 20 and 21. Dislocation of fence near Olema, Calif. Strain, near

The road running southwest from Point Reyes Station and crossing the valley at the head of Papermill Creek delta was offset 20 feet. (Fig. 23 and plate 47B.) AS the fault-trace at this point was between 50 and 60 feet wide, and as the embankment of the road for that distance was broken into several pieces, it was not possible to make certain that the dis severed remnants of the road had originally been in exact alinement. It is probable, however, that the road was approximately straight before the earthquake, and that the exceptionally great offset at this point is to be explained as the result of a horizontal shifting of the surface materials. The embankment of the road rested on marshy ground so soft that a portion of the embankment sank into it, and material of this character was in other localities demonstrably shifted.

A number of other measurements of displacement were made, but these, for various reasons, do not seem worthy of record, altho some of them were noted in an earlier report. Several were connected with the dislocation of trails, but in every such instance the trail made only a small angle with the strike of the fault and part of it was broken up along with the fractured turf. The endeavor to find more favorable angles of intersection drew attention to the fact that because the dominant trend of hills and valleys in the Rift is northwest-southeast, the lines of easy travel, minor as well as main, are largely parallel to the fault-trace. Other measurements were connected with the offset of fences, and, altho definite in themselves, have little value because there is reason to believe they represent only a part of the local displacement. The part represented by them is in every case less than 10 feet. It is noteworthy in this connection that most farm fences which were intersected by the fault-trace either terminated within a few yards of it or changed direction at about that place. Like the trails, they were adjusted to topographic peculiarities created by earlier faulting along the same line.

The phenomena of vertical displacement are in general so irregular as to indicate that they were determined chiefly by surface conditions. Where the ground sloped toward

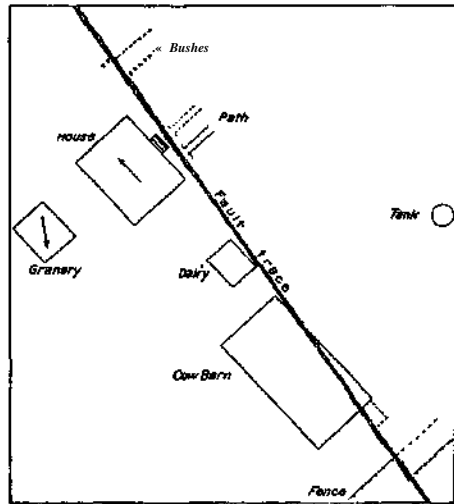

FIG. 22.—Plan of Skinner premises, showing character of displacements measured. The broken lines show positions of hushes, path, and fence before earthquake in relation to objects west of fault; also position before earthquake of corner of barn with reference to ground east of fault.

the northwest the horizontal throw caused an apparent vertical downthrow to the northeast. (Plate 48A.) Where the ground sloped toward the southeast an apparent vertical throw to the southwest was produced. Where the fault-trace followed a narrow sag interrupting the side slope of a ridge, the apparent vertical throw was on the side toward the ridge, as indicated in the diagram, fig. 6. (See also plates 10B and 48B.) The only unqualified record of vertical displacement is on Pepper Island in Bolinas Lagoon, where the mean of seven measurements shows a downthrow of 12 inches on the northeast side. The question whether the faulting along the plane of rupture was accompanied by the elevation or depression of large areas will be discussed in another place.

*Movement normal to the fault-plane.* — Where the fault-trace is a trench, imperfectly filled by fragments of soil and rock, it is clear that the walls of the fault stand farther apart than before the earthquake. Where the fault-trace has the echelon phase and consists of a system of cracks, not accompanied by visible elevation of the surface, it is also evident that the walls stand farther apart. Where the fault-trace is a ridge, composed of fragments of soil, with more or less interstitial void, it may be assumed that the voids are at least equivalent to the ridge in volume. As the fault-trace is made up almost wholly of these three phases, it follows that in the visible part of the fault its walls did not approach as a result of the faulting but receded a little.

In this connection mention may be made of the fact that at the Shafter ranch a fault crevice was momentarily so wide as to admit a cow, which fell in head first and was thus entombed. The closure which immediately followed left only the tail visible. At this point the fault-trace was a trench 8 or 8 feet wide, and the general level of the soil blocks within it was 1 or 2 feet below that of the adjacent undisturbed ground.

One suggestion in connection with the recession of the fault walls near the surface of the ground is that temporary stresses incidental to the faulting caused permanent compression of the adjacent terranes. It is a fact familiar to engineers that most superficial formations, while in their natural, undisturbed condition, have a structure involving voids, and that they may be compressed by overpowering this structure. But, if I understand the matter, such formations are not compressible (except elastically) when their voids are full of water, so that accommodation for dilatation of the fault-zone could have been made in this way only so far as the ground was dry. As the ground was full of water in many places — including,

the northwest the horizontal throw caused an apparent vertical downthrow to the northeast. (Plate 48A.) Where the ground sloped toward the southeast an apparent vertical throw to the southwest was produced. Where the fault-trace followed a narrow sag interrupting the side slope of a ridge, the apparent vertical throw was on the side toward the ridge, as indicated in the diagram, fig. 6. (See also plates 10B and 48B.) The only unqualified record of vertical displacement is on Pepper Island in Bolinas Lagoon, where the mean of seven measurements shows a downthrow of 12 inches on the northeast side. The question whether the faulting along the plane of rupture was accompanied by the elevation or depression of large areas will be discussed in another place.

*Movement normal to the fault-plane.* — Where the fault-trace is a trench, imperfectly filled by fragments of soil and rock, it is clear that the walls of the fault stand farther apart than before the earthquake. Where the fault-trace has the echelon phase and consists of a system of cracks,

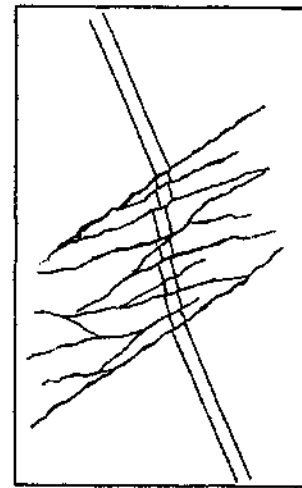
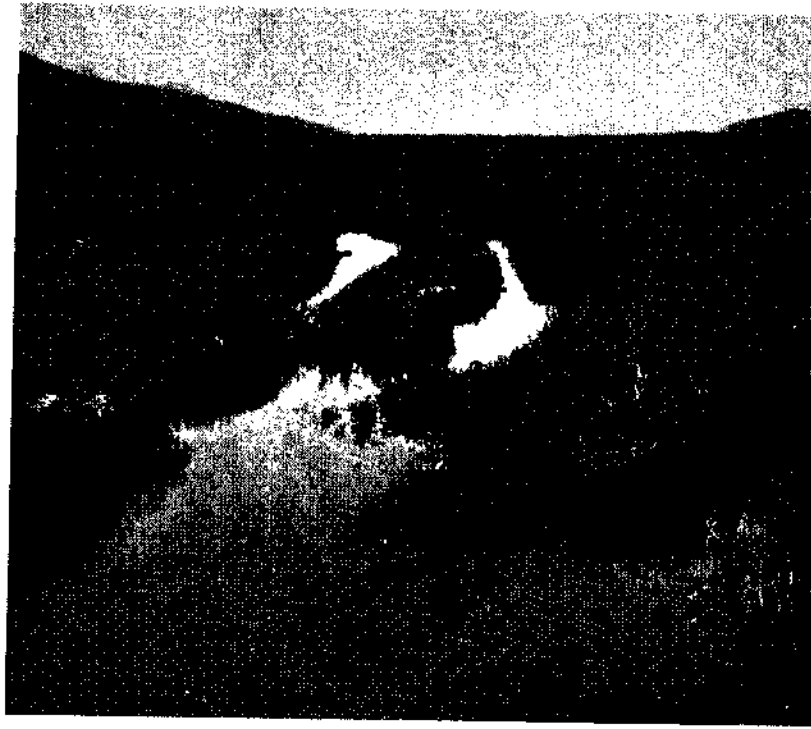

FIG. 23.—Dislocated road shown in plate 47B. Parallel lines represent wheel tracks. Ramifying lines indicate cracks of fault-zone.





A. Fault-trace on Papermill delta. Looking northwest, ff. K. G.



B. Fault-trace at the Skinner place, near Olesna. Illustrating trench ph<sub>aw</sub>. O. X. &



A. Branch of fault-trace on "north mesa" at Inverness, Looking southeast. Q. K. Q.

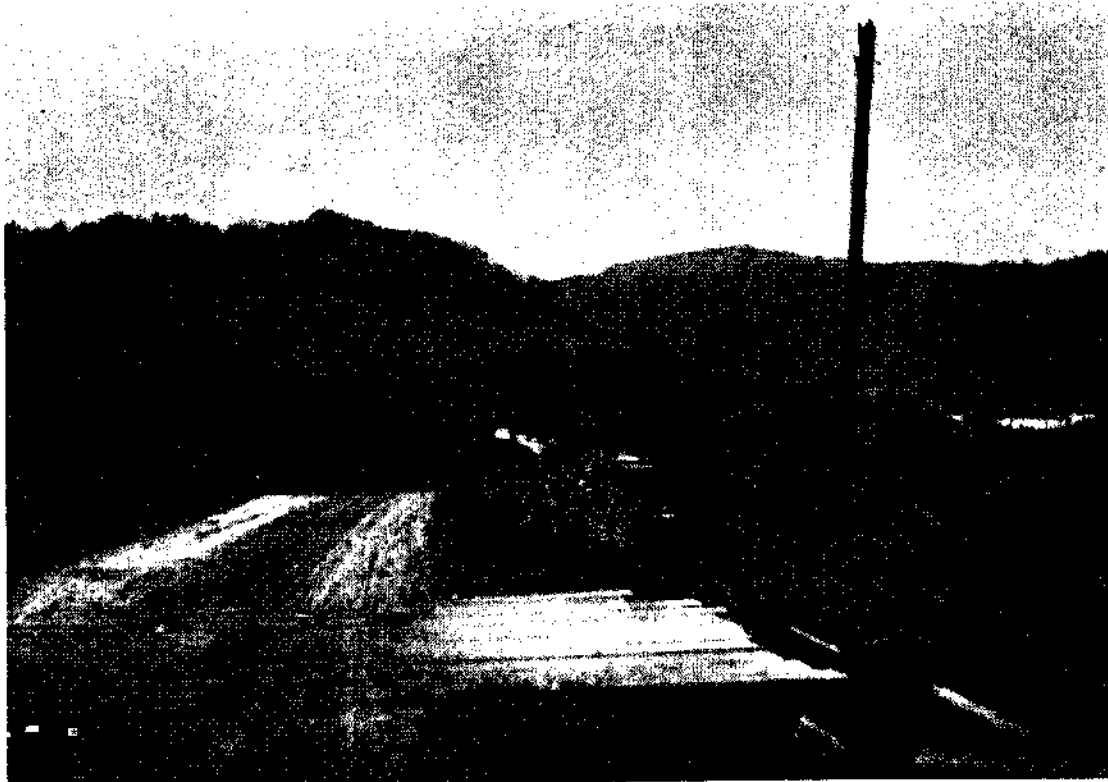

B. road offset by fault. Looking toward Mt. G. K. Q.



A. Fault-trace a mile northwest of Olema. Looking south, Appearance of vertical displacement largely due to combination of horizontal displacement with slope of ground. G. TL, Q.

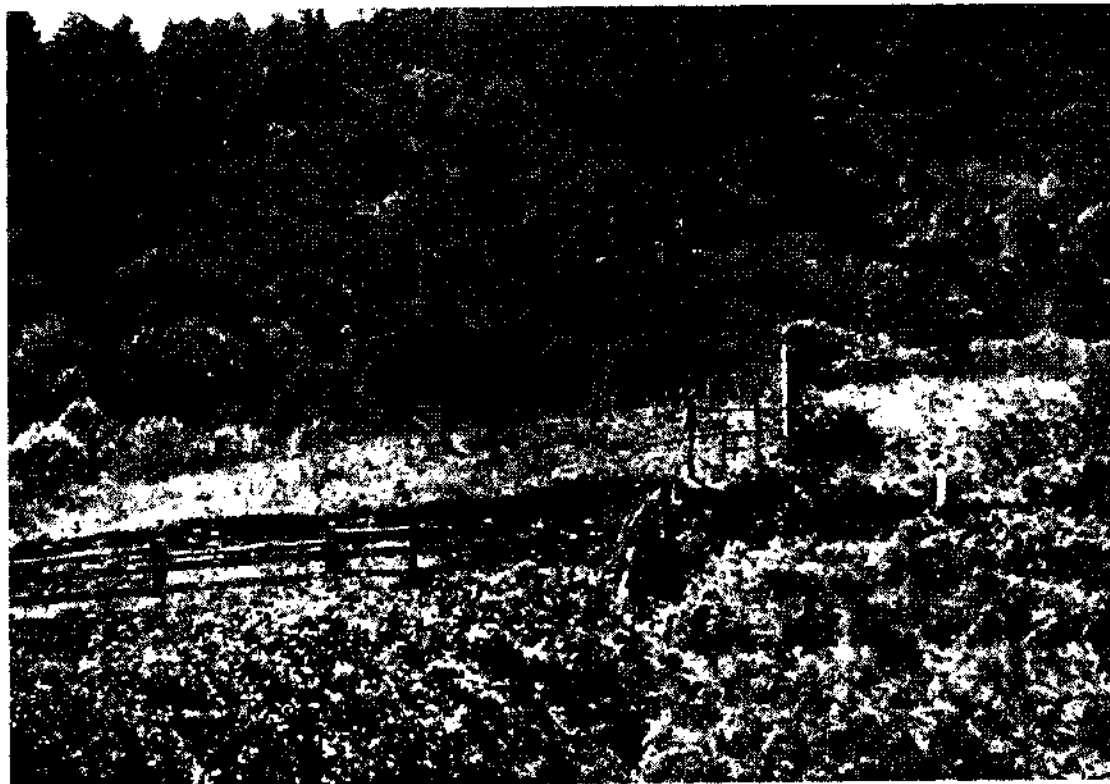

B. Fault-trace near Bear BoEdietti's ranch. Looking south. Shows vertical displacement at a sag. Horizontal displacement shows a fence, which had horizontal displacement. G. K. Q.

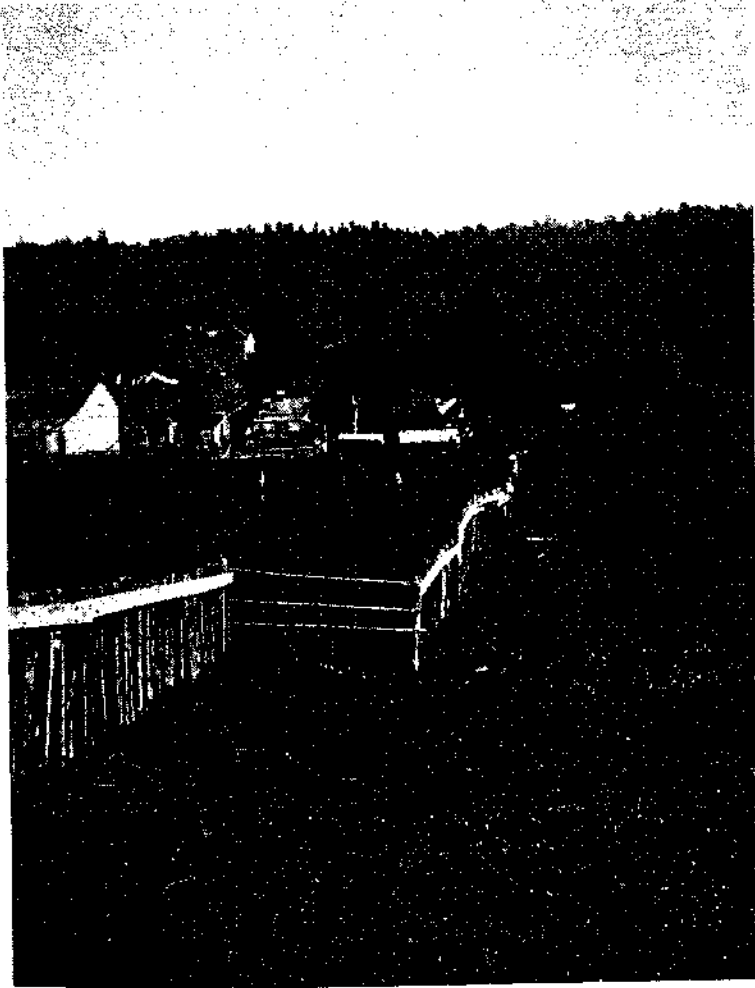

A. Fence offset by fault. Looking northwest. Camera was alined with straight part offence beyond the disturbance, to bring out flexure as well as offset of fence. Q. K. G.

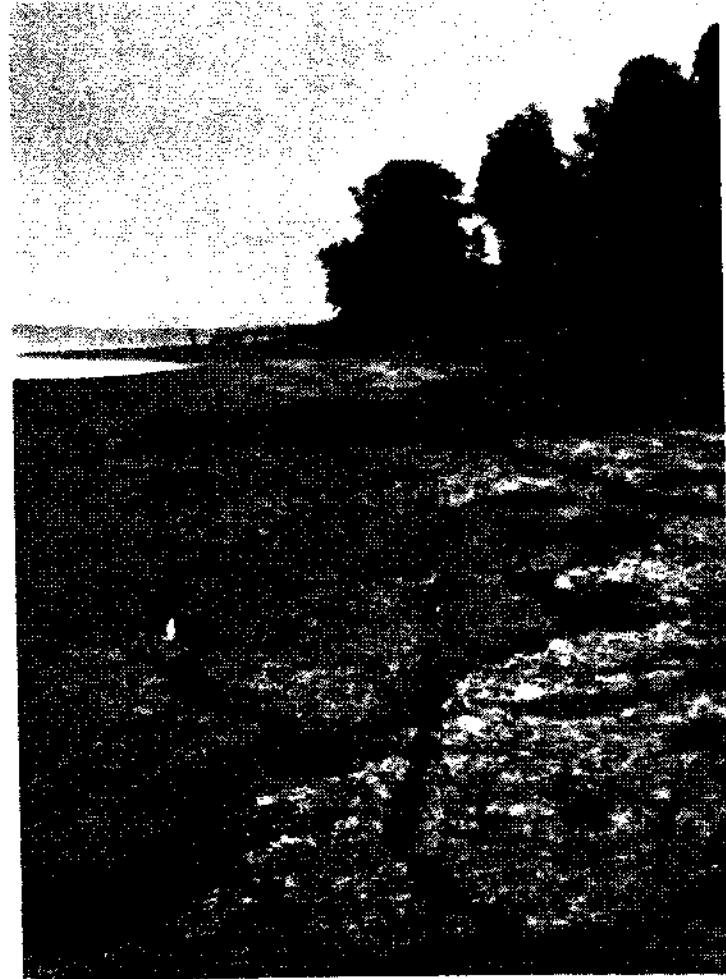

B. Cracks made by earthquake in tidal mud near head of Bolinas Lagoon. O.K.G.

for example, the locality of the cow incident, the Papermill delta, and Pepper Island — the suggestion of lateral compression seems of little avail.

Another suggestion is that the surface phenomena are essentially representative of what occurred at greater depths — that is, that in depth, as well as superficially, the faulting left the fault walls farther apart than they were before. Fissure veins show that voids have often resulted from subterranean faulting. Unless the surface along which the movement occurred is mathematically plane — or conforms to some equally difficult geometric condition — the two fault walls should not accurately fit together after the movement, but should tend to maintain contact thru only a part of their extent. If thru a part of their extent they are separated, the walls are on the average farther apart than before.

There would necessarily be some adjustment thru changes within the rock masses on the two sides of the fault. Compressive strains would be locally increased and reduced, and there would be subordinate movements among the minor earth blocks of the great shear zone whose surface features appear in the Rift. We have evidence of such adjustments, in fact, in branches of the fault-trace and in a system of bedrock cracks presently to be described; as well as in the subsidence of the bottoms of sags in the immediate vicinity of the fault. Interpreting other sag phenomena in the light of the long sag of the Papermill Creek delta, the fault of 1906 appears to have permitted a very considerable volume of material to sink into its fissure.

The general tendency of this discussion falls in line with a generalization as to the Rift, which in the Bolinas-Tomales region appears to show distinctly more local subsidence than local elevation.

*Earlier fault-traces.* — Because the future is to be judged by the past, there is much interest in the question of the frequency and recency of fault movements along the Rift previous to 1906. In my later studies of the Rift belt, I have had in mind the possibility of discovering fault-traces similar to that of 1906 but less fresh in appearance. In the little bluffs at the edges of sags, and in the ponds and marshes, there is abundant evidence of early faulting, but it is essentially geologic and does not necessarily pertain to occurrences of the past century or two. The fault-trace, however, is a relatively perishable and transient phenomenon, and its preservation might have comparatively definite meaning.

At two localities I thought I discovered old "traces" of the ridge type. In each case the features occur on a hill slope where the trace made in 1906 appears in several divisions or branches; and what I took to be old traces are distinguished chiefly by the absence of cracks. The localities are close together, about 0.5 mile south of the Shafter ranch, and may be identified by means of plate 43B. The features occur on the slope at the left, but are too indefinite to be recognized in the view. If these old traces have been properly identified, they are of very moderate antiquity. I should suppose that the ridges of the recent trace would lapse to such a condition in four or five years and that they might persist, under pasture conditions, for two or three decades. The history of the recent trace shows that a single plowing means effacement, but the general appearance of the field in which the old traces occur indicates that it was never plowed.

*Cracks.* — In preliminary reports I have classified the earthquake cracks as primary and secondary, the primary being occasioned by strains which existed before the earthquake, and the secondary being caused by the earthquake. With the multiplication of observations this classification has become increasingly difficult, and I now find it more convenient to group the cracks as superficial and deep, or superficial and bedrock.

Many of the superficial cracks are in alluvium. In the field excursions of April and May, 1906, they were seen in all alluvial formations within the Rift belt and for some distance on each side. The greater number appeared to be merely partings without

vertical or horizontal throw. In general they were not parallel with one another nor were they otherwise systematically arranged, except that some of them were apt to occur along the boundary between alluvium and a firmer formation. They were rambling rather than straight and were often branched. They ranged in width from a fraction of an inch to several inches. They were seen from the train in the bottom-land of Papermill Creek within a mile of Point Reyes Station. They were also seen in the delta of Papermill Creek, in the bottom-land of Olema Creek near Olema, and in the delta of Pine Gulch Creek. They were seen in the bottom-lands and deltas of a number of small creeks entering Tomales Bay from the west between Inverness and the head of the bay. Other localities were tidal marshes at the head of Bolinas Lagoon (plate 49B), at the head of Tomales Bay, and in small estuaries near Inverness. They were seen in the marsh of Bear Valley Creek near where the stream joins Papermill Creek; and a road embankment crossing that marsh was elaborately cracked and faulted thru much of its extent.

It is noteworthy that the neighboring road crossing a marshy portion of the Papermill delta was much less cracked, and the difference is probably to be ascribed to the difference in height and strength of the two embankments. The thinner one suffered the more.

The localities enumerated are merely those which came under observation. Within the zone of high intensity no marshes and no bottom lands were seen which did not exhibit cracks, and I regard their cracking as a general phenomenon. The elaborate cracking of a roadway across one of the marshes seems specially significant. In the adjacent soft marsh close attention was necessary to discover cracks. To a large extent they were concealed by the vegetation, and it is probable also that many which were opened during the earthquake agitation immediately closed again and were practically obliterated by the welding of the mud. But the road embankment, being free from vegetation and composed of comparatively rigid and brittle material, retained all the cracks made during the agitation, and thus served to record the thoro shattering of an unconsolidated formation when subjected to strong vibration. (Plate 50.)

Another class of superficial cracks affected hillsides, penetrating only the coating of loose material — decomposed rock and talus. The conspicuous individuals of this type are those that follow contours. Along these there was often a notable width of crack, accompanied by a settling on the down-hill side, and many cracks of this type are still visible. They are in effect the heads of incipient landslides and might with equal propriety be described under another caption. They are numerous thruout the Rift belt and fairly abundant on steep hillsides for more than a mile to the west. East of the Rift they are inconspicuous and believed to be rare. Some of the best examples are on the northeastern slope of Mount Whittenberg, about a mile from the fault-trace, the locality being favorable for observation because of the absence of forest.

Superficial cracks of a third type are connected with side-hill roads. (See plate 51.) In such roads there is usually a notch cut in the hillside and the excavated material is thrown outward so as to make an embankment. The roadbed thus consists in part of the natural formation and in part of an artificial and relatively loose embankment. In the loose material, and frequently along the line separating it from the firmer ground, cracks were extensively developed, often accompanied by evident settling of the outer bank. Their magnitude depended in part on the character of the material, but in large part also on the intensity of the earthquake. Where they were of such magnitude as to injure the roadway they were soon obliterated by road repairers, and elsewhere they tended to disappear in consequence of the traffic; but while they lasted they constituted an excellent gage of intensity, and much use was made of them in districts where there were few buildings\*

Bedrock cracks occurred at many points within the Rift, usually appearing as branches from the faults. They were seen also at a number of points west of the Rift, their distribution reaching to the ocean in the vicinity of Point Reyes, ten miles from the fault-trace. At the more remote points they were quite small, often barely discernible, and no system of arrangement was discovered. They are peculiarly prominent along the summit of the ridge constituting the southwestern rim of the main Bolinas-Tomales trough. This summit was visited on four lines of road, and at each locality conspicuous cracks were found. On the road from Inverness to Point Reyes Post Office, about a mile in a direct line from Tomales Bay, a crack was traced for more than 800 feet. Its general trend is east and west, but its course is not straight and it has a branch diverging at  $45^\circ$ . Along this crack there is a horizontal throw of from 2 to 6 inches, the south side having moved westward with reference to the north side.

On the next road to the southward a group of cracks was seen at a point a mile from the shore of Tomales Bay. These cracks occur on a crest trending northwest and southeast, and their trend makes a small angle with that of the crest. The arrangement of the cracks suggests horizontal shear, but no definite observation was made on this point. They extend for several hundred feet at least, but were not traced out.

On Mount Whittenberg there are two bedrock cracks. One of these crosses the northeastern spur of the peak near its junction with the main crest. Its trend is approximately northwest and southeast and at one point it margins a fault-sag. As it assumes in one place the ridge phase of the fault-crop, I infer that it has horizontal displacement. On the opposite side of the main crest is a crack which was traced for about 1,000 feet. Its general course is northwest-southeast, but it is not straight and exhibits a vertical throw of 1 or 2 feet to the southwest. At one point it touches a fault-sag. Between these two long cracks a group of short cracks occurred, with similar trend, on a knob constituting a portion of the main divide.

About 6 miles farther south, at the head of Pine Gulch Creek, another road crosses the range, and in following this a group of cracks was seen. A short distance west of the divide, and about a mile in a direct line from the fault-trace, is a fault-sag trending northwest-southeast. On each side of it a crack was seen, the eastern crack being the wider and showing a small throw to the southwest. This crack was traced for about 0.75 mile and found to curve thru an arc of nearly  $90^\circ$  from southeast to southwest. At its southwest end, or at least the southwestern limit of tracing, it is on a ridge, and it there expands into, or else is replaced by, a group of cracks diverging fan-wise. On each member of the group faulting took place, the downthrow being toward the northwest except in the case of two apparently short cracks with downthrow to the southeast. On four of these cracks the throw was greater than 1 foot, and at one place it was about 5 feet. Each crack was associated with a preëxistent bluff or scarp, indicating that earlier movements have occurred at the same place. The field in which the principal phenomena occur is cultivated with the exception of the steeper scarps, whose faces retain a bushy growth. (See plates 52A and 53A.)

A tract lying between this locality and the coast, and extending several miles in each direction, exhibits a peculiar topography intermediate in type between that of the Rift and that commonly associated with landslides. Near the coast are a number of basins with ponds or lakes of much larger size than those along the Rift, and in association with these are seen a number of sags similar to the fault sags of the Rift. On several lines which were thought from the physiography to represent partings between dislocated blocks, earthquake cracks were seen, and on one of these near the coast there was a vertical displacement of 3 feet, the downthrow being to the southwest.

All thru the Rift there is association of earthquake cracks with fault-sap; probably half of the sap were bordered by such cracks on one side or the other, the crack usually

following the line of separation between the side slope and bottom slope. In some instances there was a crack on each side of the sag, but more frequently on one side only. Where the sag contained a pond the crack was usually present. With little or no exception these cracks exhibit downthrow on the side toward the sag. (See plate 52B.) At least two explanations of these cracks are possible. As the bottom of the sag usually shows no outcrop of rock and appears to consist wholly of soil washed down from the sides, it is possible that the earthquake caused a settling of the alluvium toward the middle of the sag and that the marginal crack is due to this settling. On the other hand, it is possible that a bedrock wedge underlying the sag was permitted to settle during the earthquake and that such settling caused the marginal crack. In the first case the cracks would belong to the superficial class; in the second, to the bedrock class. While the data at hand are not decisive, I am of opinion (as already stated) that the cracks resulted from some sort of readjustment of the small earth blocks whose upper surfaces determine the Rift topography.

*Springs.* — The general testimony of residents is that the flow of springs was modified all thru the peninsula west of the Rift. As it was practically impossible to get quantitative data, I made few records of specific instances, but every farm owner or farm tenant of that region with whom I talked told me of some spring whose flow had been increased, diminished, or stopt at the time of the earthquake, the change being either temporary or permanent. Several lakes of the group near the coast (known as Seven Lakes) experienced changes, the greater number having their levels lowered. A pond known as Mud Lake, on the divide at the head of Pine Gulch Creek and about a mile from the fault-trace, suddenly and permanently lost its water at the time of the earthquake. At the same time a small spring on the east side of the ridge and about 0.75 mile in a direct line from the pond, was suddenly enlarged, a torrent of water gushing from it for several hours and then gradually diminishing. It is suggested with much plausibility by residents that these two phenomena were connected, the earthquake opening a subterranean course thru which the water of the pond was conveyed to the hillside spring. I heard of no changes in springs east of the fault-trace, altho a number of inquiries were made.

*Interpretation of bedrock cracks and springs.* — The changes in springs are of course the results of changes in the conditions of underground circulation, and in a general way may be ascribed to the influence of newly-formed cracks. The spring phenomena and the visible cracks may be grouped together as indications of bedrock fracturing, and their distribution indicates the regions in which the rocky foundation of the land was more or less shattered. That region includes the Rift and extends from it to the ocean. The phenomena diminish somewhat with distance from the Rift, but the fracturing appears to have been important and general thru a belt 4 or 5 miles broad.

*Landslide®.* — The earthquake started a number of landslides. A few of these were on the line of the fault, especially where its trace intersected a cliff facing Bolinas Lagoon. Others were from cliffs of earth or weak rock bordering the ocean, one of the bays, or a creek. None were seen of unusual type or of great importance, except from the obstructions to roads which they occasioned. South of Willow Camp a road overlooking the sea had been cut in the face of previous landslides, and the renewed movement put it out of commission. In the same manner roadways were obstructed at the entrance to Bolinas Lagoon, at two points near the head of the lagoon on the west side, and on the coast of Tomales Bay at Inverness.

There were many landslides of the dry type on hillsides, masses of earth and rock breaking away on steep slopes and tumbling to the bottom. The largest seen were on the high ridge west of Tomales Bay, in the vicinity of Sunshine Ranch. Closely related to these were small falls of earth and rock from the low cliffs created in the construction of side-hill roads. (Plate 53B.) They occurred at a few places within the Rift and



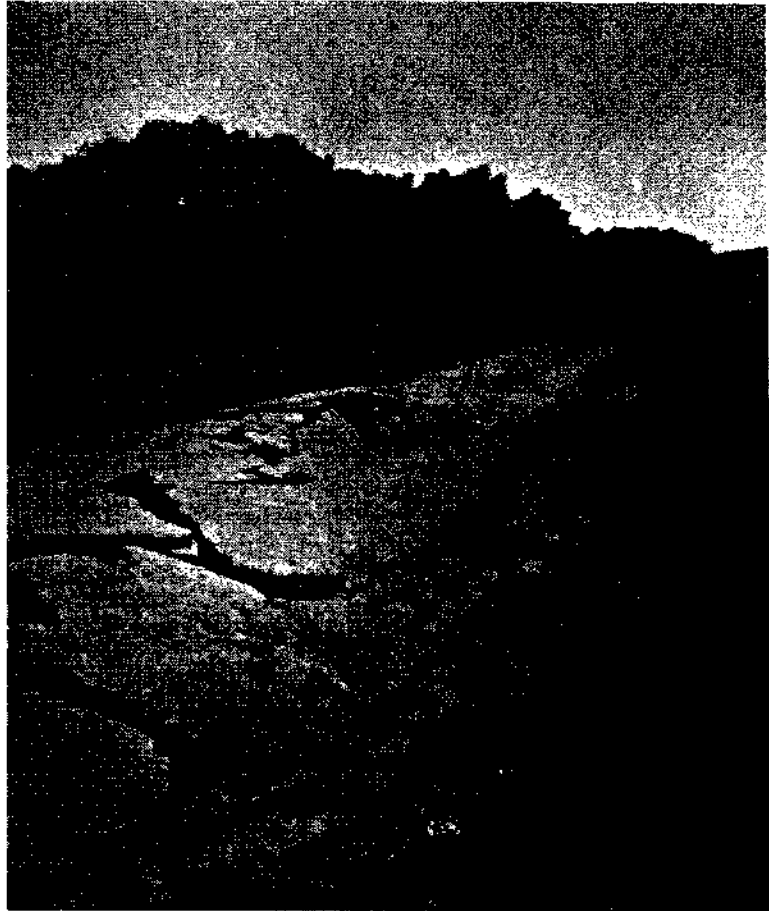

A. Road embankment broken by shaking of soft ground beneath. Southwest of Point Beyes Station and 10 rods from fault-trace. Q. K. Q.



B. Faults in road embankment, southwest of Point Beyes Station. Fault-trace is beyond fence. Ground level toward marsh of Bear Valley Creek. Q. K. G.



A. Roadside crack 2 miles west of fault, between Inverness and Point Reyes P. O. G. K. G.



B. Roadside crack a mile southeast of Inverness. G. K. G.



A. Group of earthquake cracks southwest of head of Pine Onion Creek. Looking southwest. Structure well indicated by sky line. Since dislocation field has been plowed and farm road graded up fault-scarpi. Compare Plate 53 A. G. I. &



B. Earthquake cracks in BolinM at tip of aa M4rtfefwi» ••{. Q- K. Q.

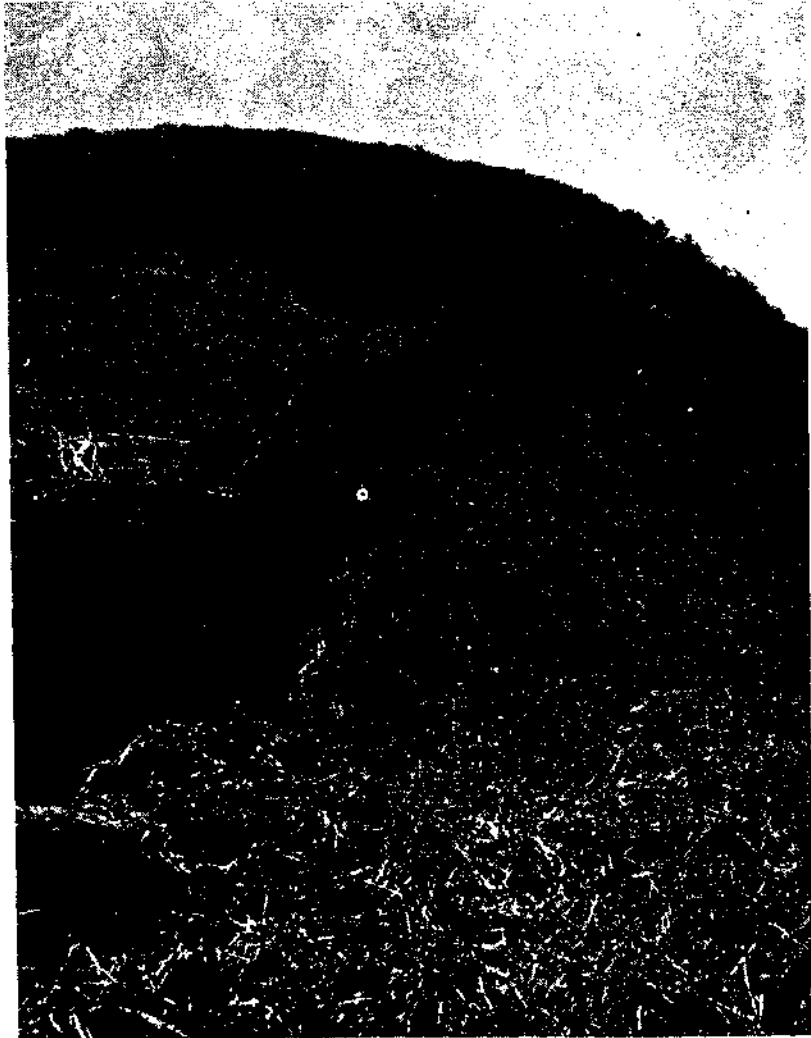

A. Fault-scarp on earthquake crack. Throw is about 5 feet. Compare Plate 52 A. (J. T. J.)



B. Landslide from road-cliff about two miles west of Inverness. Slide occurred at time of earthquake. (G. K. &)

east of it, but mostly in the district to the west, where all of the country roads were more or less obstructed.

On the west side of the main ridge west of the head of Tomales Bay there occurred two wet slides. In one case a hillside bog was loosened from the slope on which it rested and descended as a flow of mud to a canyon bottom 100 or 200 feet below. In the other case the earth beneath a wet meadow in a rather steep canyon flowed down the canyon for about 0.5 mile, overpowering trees on its way and leaving a deposit 15 or 20 feet deep in places. This was the largest individual slide observed.

In all the cases mentioned the conditions were such that slides would have taken place at some time had the earthquake not occurred. But this statement may not properly apply to the cases about to be mentioned.

On the steep southern face of Mount Tamalpais a number of rocks were loosened and rolled down the slope, some of them being large enough to cut swaths thru the thicket which were visible for months afterward. Similar swaths were seen under a crag in the vicinity of Willow Camp. In the bottom-lands of creeks it happened at many places that a slice of the alluvium was separated by a crack parallel to the bank and slid into or toward the stream. In some cases alluvium lying with a gentle slope adjacent to a marsh slid toward the marsh, opening a crack along its upper edge.

Mention has already been made of numerous hillside cracks which marked incipient landslides. In such cases the downward motion apparently began during the earthquake agitation, but the momentum acquired was not sufficient to continue the motion after the earthquake stopt. In a very large number of these localities motion was resumed and landslides occurred during a period of excessive rainfall in the spring of 1907. (Plates 54A and 55A.) SO far as my observation goes, all of the landslides having this history were wet, the material usually flowing freely down the slope as a thin mud. The probable explanation is that the cracks made in April, 1906, served to admit the water flowing over the surface during the rains of 1907, so that the material which was too dry to flow in 1906 acquired the proper consistency and continued its course the following year. The number of landslides which the earthquake induced in this indirect way is possibly as large as the number which were an immediate consequence of the shock.

The phenomena of landslides bring to attention certain conditions of flow which affect a variety of earthquake features. Consolidated formations hold steep slopes by virtue of cohesion. Incoherent formations maintain the "slope of repose" —  $30^{\circ}$  to  $35^{\circ}$  — by virtue of the resistance to sliding, or the static friction, of their particles. Certain formations, including some clays and clay mixtures, become coherent by drying and incoherent by wetting. Incoherent formations, as a rule, have a less coefficient of friction when wet than when dry. For these reasons the addition of water is the ordinary immediate cause of a landslide; it overcomes cohesion, or else it reduces the frictional resistance, and slipping or flowing is the result. During a strong earthquake, agitation overcomes the cohesion of feebly-coherent formations and suspends the operation of static friction between the particles of incoherent formations, thus affecting the materials somewhat as water affects them. In the case of landslides, it may enable an incoherent dry formation to flow as if wet; and it may temporarily give to an incoherent formation, wet or dry, a condition of quasi-liquidity.

*Ridging and shifting of tide lands.* — The general width of Tomales Bay near its head is about a mile, tho it is constricted at one point by a promontory jutting out from the east shore. (Fig. 24.) Papermill Creek, entering at its head, has built a delta which slopes so gently toward the deeper water that the tides range over it for a distance of about 3 miles. The upper half of the slope is covered by vegetation of various kinds and the lower half is of bare mud. In the region of vegetation the soil has sand as well as mud, and the bed of the stream is of sand and gravel. As the delta deposit has been

built up in connection with a shifting of the stream channel, or channels, it is probably composed of an irregular alternation of mud, sand, and gravel. The fault-trace, as already described, passes thru the midst of the tide lands, following the axis of the depression which contains the bay. Continuous with the mud of the lower slope of the delta is a mud shoal following the western shore of the bay past Inverness. This shoal and other parts of the tide lands were seen soon after the earthquake from the road which follows the west shore of the bay to Inverness, and a few photographs were made. Other photographs were made at various dates afterwards, and the tide lands were explored on foot on April 18, 1907.

A large portion of the delta was thrown by the earthquake into gentle undulations, the difference in height between the swells and hollows being usually less than a foot.

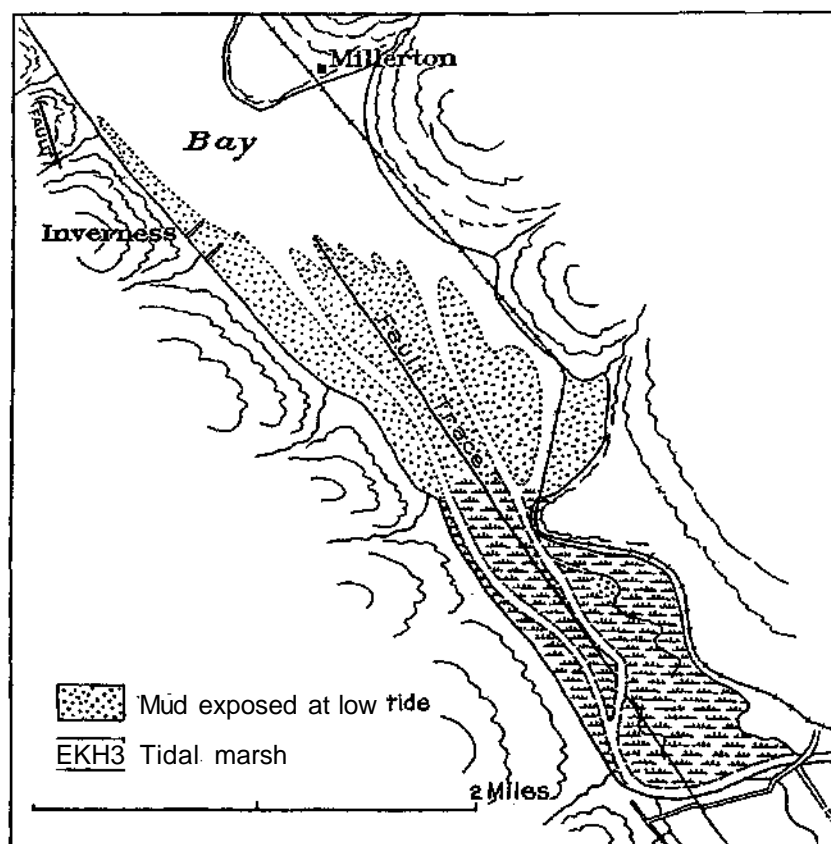

FIG. 24. —Map of Papermill Delta at head of Tomales Bay.

The chief evidence of this is found in the distribution of pools at low tide, and where vegetation is present the evidence from pools is supplemented by that from the condition of the plants. The undulations were not elongate and were not found to have a systematic relation to the fault.

When the tidal mud was first seen after the earthquake, it was observed to be covered with ridges and troughs. (Plate 54B.) This corrugation was gradually smoothed out by the action of the waves (plates 55B and 56A), SO that at the expiration of a year its expression was largely lost, tho a few of the larger ridges could still be traced, and much of the plain retained a pattern imprest on it by the ridging. It is probable that the entire tract of tidal mud was thus affected, altho the ridges were not seen on the area lying nearest to the east shore. That area did not come under observation until after the spring floods



A. Landslip 4 miles northwest of Bolinas Lagoon. Looking south-southwest. Slide caused by rains early in 1907, indirectly by earthquake of 1906. <sup>caused directly</sup>



B. Bidgod and plain 1 mile from Bolinas Lagoon. Looking south-southwest. Haass's bar at right. April 38, 2906. Tide us low, Pools occupy the depressions. U. S. G.



A. Landslides 2.5 miles northwest of Bolkas Lagoon. Looking northeast. Storm waters of 1907, guided by earthquake cracks, converted earth into soft mud. G. K. G.



B. South part of Inverness shoal, at low tide, April 23, 1906. Looking north-northwest. Lane of water separates firm, gravelly beach from mud shifted shoreward by earthquake. G. K. G.





A. Edges caused by earthquake on tidal flat of Tomales Bay, 1 mile south of Inverness. Looking north. December, 1906, & K. Q.

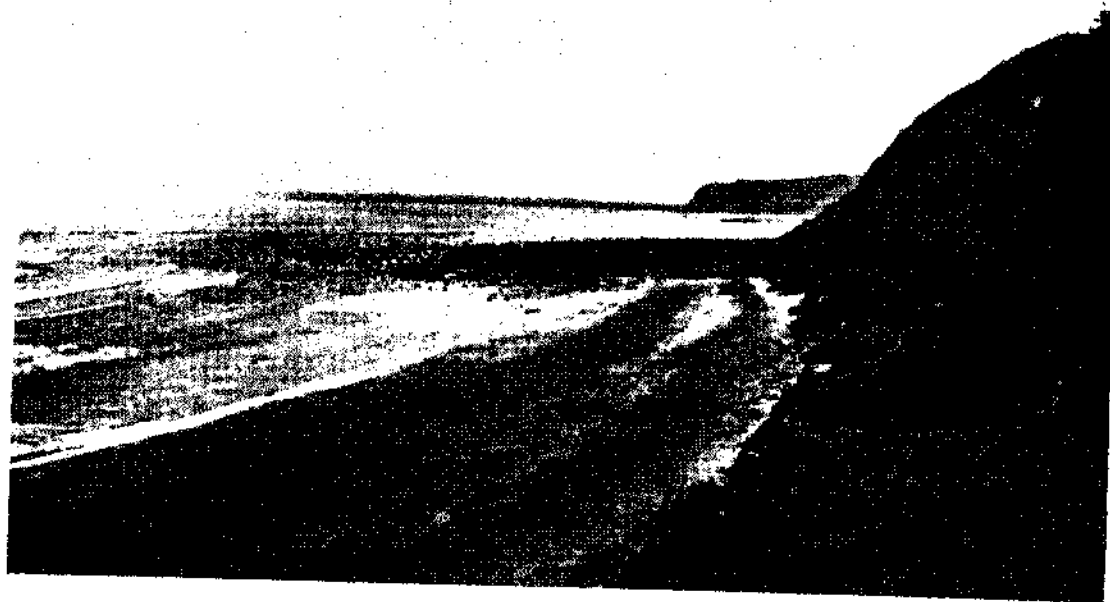

B. Bed-rock shoal Bear Boliaas, with clam patch near water edge. Dnxttry Point au3 reef is the distance. G. K. Q.



C. Olam patch near Bolinas. A bed-rock platform, exposed at low tide. Photographed November 25, 1906.



D. Salicornia in Liraantoor Bay. Photographed Jnns 5, 1907, during low tide. Shows a platform covered by »B older growth, and a colony of yobHger plants at a lower level.

of 1907, and it was then overspread by a fresh deposit brought by Papermill Creek. The ridges varied somewhat in height, the amplitude from crest to trough ranging from 1 to 3 feet and possibly more. Their general trend was parallel to the fault-trace, but there were notable exceptions, and over small tracts the direction was even at right angles to it. In some cases, where the minor ridges were parallel, there were larger ridges traversing them obliquely. Fig. 25 reproduces a sketch map of the locality showing the greatest complexity. So far as the broad undulations of the tide lands were seen in conjunction with the ridging, the greater ridges were on the swells and not in the hollows.

Without going deeply into the question of interpretation, it would seem that in the production of this ridging the tidal mud must have behaved as a quasi-liquid, being thrown into waves by the agitation to which it was subjected. When the agitation ceased it became once more a quasi-solid, and preserved the form it had at the moment of change.

There was also a horizontal shifting of mud over a considerable area. Residents familiar with depths of water in the vicinity of Inverness stated that the earthquake caused a decided shoaling along the coast, but that the relation of water levels to firm ground was unchanged. It was also stated that a channel which had existed parallel to the west shore of the bay, and to which piers had been run, was obliterated by the earthquake. The shoaling might have been caused either by an uplift of the bottom or by a shifting of the mud of which it is composed toward the shore. That the second of these explanations is correct seems to be shown by the following facts.

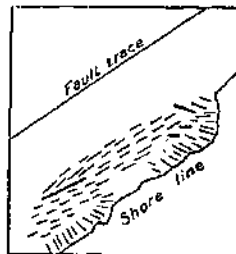
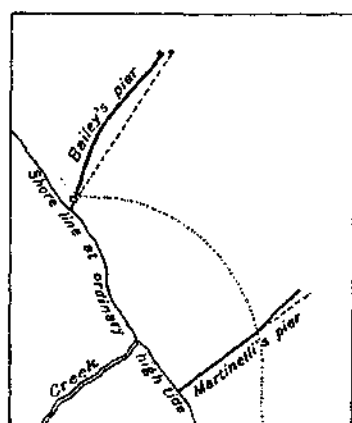
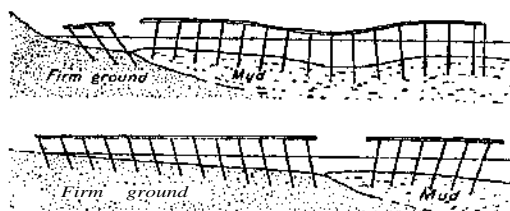

FIG. 25.—Arrangement of ridges on tidal flat near Inverness. Map.



26.



27.

FIG. 26.—Sketch of Inverness piers. Full lines show positions of piers after earthquake; broken lines show positions before earthquake. Dotted line shows shoreward limit of the shifting of bottom.

FIG. 27.—Diagrams with exaggeration of vertical scale, to illustrate deformation of Inverness piers by shifting of mud toward the shore. Bailey's pier above; Martinelli's below.

At various places along the shore, from Inverness to a point 1.5 miles southward, the tidal mud seemed to be crowded against the firmer ground at the shore, being pushed up in a ridge, as shown in the accompanying photograph. (Plate 55B.) TWO piers at Inverness, light wooden structures, resting on piles and extending out several hundred feet from the shore, were telescoped. (Figs. 26 and 27.) In the case of Martinelli's pier the telescoping was shown by the inclination given to piles at the landward and bayward ends, from which it appears that the ground in which the piles were set was crowded together, so that the foundation of the pier was shortened, while the superstructure resisted shortening. The resistance was temporary only, for before the agitation ceased the pier was broken in two; and the inclination of the piles is supposed to have been given during the early stages of the tremor. Coincident with the movement of the

ground toward the shore, there was a movement parallel to the shore which had the effect of offsetting the outer end of the pier about 25 feet toward the northwest. (Plate 57A.) The resultant of the two movements, or the actual direction of shifting of the mud, was westward, or a little to the north of west; and the maximum shifting in that direction was not less than 30 feet. Rather more than half the pier, the part nearer the shore, remained straight and suffered chiefly from the slanting of its supporting piles. This part stands on the submerged delta of a small creek, and its foundation appears not to have shifted. The outer part suffered most violence near the junction of the shifting mud with the firmer ground, being there so completely wrecked that its platform fell. The photograph and map represent it after repairs had been made.

In the case of Bailey's pier, which is beyond the delta, the most important telescoping, as shown by the slanting of piles (fig. 27), was close to the shore, and nearly the whole structure was transported by the shifting mud. It also sagged more than a foot just beyond the middle, and the attitudes of the associated piles suggest that the sag corresponds to a hollow made in the surface of the mud. The pier was so badly broken as to require extensive repairs, and in making these repairs Mr. Bailey used the old material for flooring, but found that he had enough lumber remaining for 12 feet of flooring, so that he inferred a shortening of 12 feet. The whole pier was shifted to the northwest, being given a curved form (plates 57B and 58), and the maximum amount of shifting in that direction was at least 25 feet, altho the circumstances did not admit of accurate measurement. Combining the movement toward the shore with the offset parallel to the shore, it is probable that the direction and the maximum amount of shifting were about the same as in the case of the Martinelli pier.

It is a notable feature of this displacement that the disturbed material moved up the slope instead of down, so that the transfer was not only independent of gravity but opposed to it. The phenomenon, therefore, does not fall in the same category with landslides, and if properly interpreted it may throw light on the mechanics of the earthquake pulses.

The area thru which the shifting of the mud took place is indeterminate. It affected a shoal parallel to the west shore of the bay and more than a mile long. At the piers the width of the affected region was at least 400 feet and may have been much more. The reported closing of the channel suggests 700 or 800 feet as a minimum estimate, but the outer margin of the affected area was probably beneath the water of the bay and outside the range of observation. The firmer part of the Papermill delta appeared not to be included in the movement. All of the area known to be affected lies southwest of the fault-trace, which in that neighborhood is about 2,000 feet from the shore.

#### THE QUESTION OF LOCAL ELEVATION AND DEPRESSION OF LAND.

*Introductory.* — Dr. C. Hart Merriam was told by an Indian living near Marshall, on the northeast shore of Tomales Bay, that since the earthquake the clam belt on that shore had been less accessible. The tides also came higher than formerly, the highest tides surrounding his cabin, whereas formerly they did not reach it. Mr. C. J. Pease, of Olema, also stated that the clam industry on the northeast shore of Tomales Bay had been much injured by changes due to the earthquake. Thru President D. S. Jordan I was put in communication with Dr. S. S. Southworth, of Bolinas, who reported various phenomena indicating a lowering of the land on the east side of the fault, and a lifting on the west side. On September 27 and October 15, 1900, being in Bolinas and its vicinity, I made a preliminary examination of some of the features described by Dr. Southworth. They were of such a character that it seemed desirable to enlist the aid of zoölogists and botanists, and to this end a conference was soon afterward called in



A. Martinelli's pier at Inverness. Originally straight; shifted and broken by earthquake. Repaired before photograph was taken. G. K. & G.

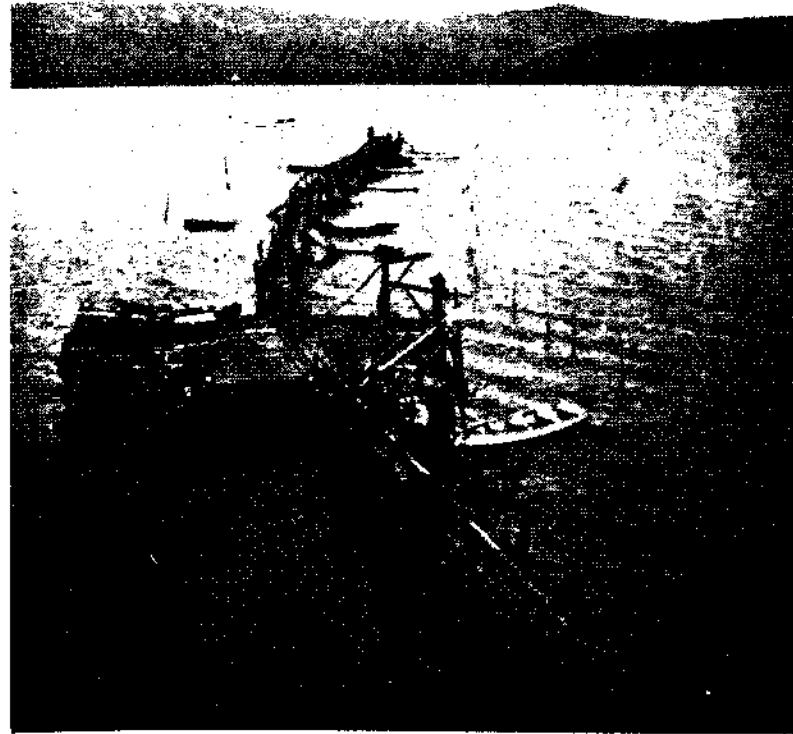

B. Bailey's pier at Inverness. Originally straight; shifted and much broken by earthquake. In subsequent repairs curvature caused by earthquake was retained. G. K. & G.

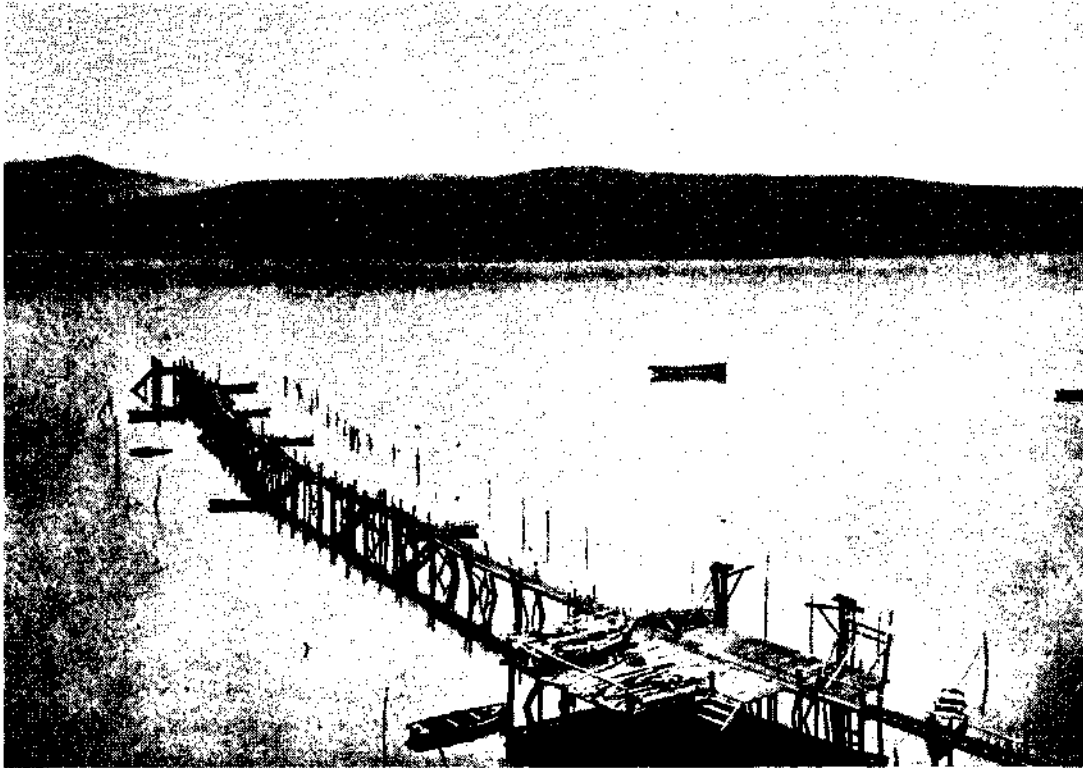

A. Bailey's pier at Inverness. Another view, position of camera being approximately same as in making photograph below, taken before the earthquake. G. K. Gh



B. Bailey's pier at Inverness, before earthquake. Photographed by Martha F. Schreiber. Compare A of this plate.

Berkeley, and arrangements were made for field examinations by naturalists. On October 26 Professor William E. Bitter and Mr. E. L. Michael went to Bodega Bay, where they spent several days, and at the same time Profs. Chas. A. Kofoid, H. B. Torrey, and R. S. Hoiway visited various points on the shores of Tomales Bay and Tomales Peninsula. On November 24 and 25 Professor Kofoid accompanied me to Bolinas for the purpose of gathering such evidence as might be afforded by marine invertebrates. On March 8-9, 1907, Professor Holway and I visited Bolinas, and on April 9-10 I was accompanied by Professor Willis L. Jepson in the same locality. On April 18 I made an examination of the Papermill Creek delta at the head of Tomales Bay, and on April 22 visited the sand-spit separating Bolinas Lagoon from the ocean. The results of these various excursions are summarized below, and reports by Professors Ritter, Kofoid, Holway, and Jepson are appended.

*About Bolinas Lagoon.* — In presenting the evidence as to land-movements in the vicinity of Bolinas Lagoon, first place will be given to testimony of residents, and this again will be classified according to locality, beginning with the features west of the fault-trace.

Dr. Southworth has lived in Bolinas several years, and his activities during that period have led him into almost continuous observation of the coast and the tide. There is a clam patch on the ocean front between Bolinas and Duxbury reef (see fig. 28 and plate 56B), to which he has frequently resorted at suitable stages of the tide. It has been his custom regularly to consult the tide tables to ascertain whether the water stage would expose the patch. He reports that before the earthquake there were ordinarily about four low tides in the month, occurring by daylight, during which clams might be obtained, and that since the earthquake twenty or more days are available. He infers that the land was lifted at least a foot, possibly more, at the time of the earthquake. He states also that about 5 miles to the northwest there is a tract, exposed only at low tide, where abalones are abundant, and that people living near there have found them much more accessible since the earthquake than before. In Bolinas Lagoon a channel between Pepper Island and the mainland is not now navigable at certain tide stages which formerly made it entirely navigable.

Dr. Gleason, owner and master of a vessel plying between Bolinas and San Francisco, states that formerly it was his custom to turn his vessel in the channel between Pepper Island and the west end of the sand-spit, but that after the earthquake he found the place too shoal, so that, after a number of trials in which his vessel was grounded, he has adopted the practice of entering the lagoon stern first, to avoid the turn.

The following observations pertain to localities east of the fault. A road which skirts the northeast shore of the lagoon is not altogether on the mainland, but in places follows the strand between high and low water, and if it is used at high water the horses must ford. Dr. Southworth states that since the earthquake these fords have become more difficult, so that to pass them safely or comfortably they must be reached when the tide, as indicated by the tables, is lower than was formerly necessary. Mr. B. C. Morse, however, who lives on the mainland east of McKennan Island, and who ordinarily crosses the lagoon to Bolinas every day, states that he has noticed no change in the relation of

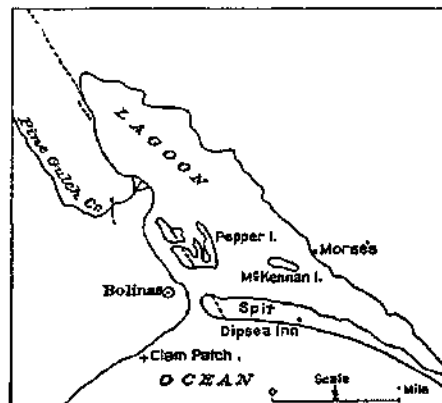

FIG. 28. — Sketch map of Bolinas Lagoon. Broken lines show fault-trace and its branches.

water to land along his water-front. Dr. Southworth has found the navigation improved at various places in the eastern part of the lagoon, the water being deeper than formerly for the same normal state of the tide, and this observation is confirmed by Mr. Morse, who now at high tide sails over a portion of McKennan Island which could not formerly be crossed with a boat. Various residents are of opinion that the sand-spit, except at its extreme western end, is lower than formerly. A lady who has lived at Dipsea Inn several years states that before the earthquake the spit was overtopped by waves only during storms with heavy winds, but that since the earthquake waves frequently wash over it.

It will be observed that all this testimony, with the single exception of Mr. Morse's observation of water-levels near his house, tends to show a general sinking of the land east of the fault, and a general rising of that to west of it.

Professor Kofoid, in seeking evidence from the distribution of marine life, found the barnacle the most available form. It is abundant at many places; its shell remains as a witness after the death of the animal, and its upward limit bears, at many places, a definite relation to the line of high tide. The best places found for observation were certain groups of piles at Bolinas and along the northeast shore of the lagoon. From a study of these localities it appeared that in the upper part of the barnacle zone the percentage of dead shells is notably greater on the west side of the fault than on the east side, but there is not a well-marked zone of dead barnacles on the west side, nor is there a zone of exclusive young barnacles on the east side. The evidence thus gives a qualified support to the theory of elevation and subsidence. Outside the lagoon, on the open sea-front, the upper limit of barnacles is too indefinite and irregular to be available for a study of this character.

Visiting Pepper Island in company with Professor Holway, I found the position of the fault-trace clearly indicated by a difference in the color of the vegetation. The island is low, only a narrow strip at the south remaining above water at ordinary high tide, and from this strip there is a gentle slope toward the north and northwest. The vegetation on the highest part is somewhat varied, but the lower slopes are occupied almost wholly by a single species of *Salicornia* (pickle-weed). This is locally the lowest lying of the shore forms, and it descends the slope to a somewhat definite line beyond which the mud is bare. It is evident, therefore, that its lower limit is determined purely by physical conditions and not at all by the competition of other plants. It is thus peculiarly sensitive to changes in the relation of land to water. West of the fault a broad area covered by this plant presented, at the time of the visit, a brownish-green color, while the adjacent areas east of the fault had a dull brown color. The contrast was so strong that the eye could readily trace the line of the fault. We found also that the ground east of the fault was, in general, lower than the ground at the west, and I afterward made a series of measurements showing the average difference in elevation to be 12 inches.

Pepper Island was subsequently examined by Professor Jepson, who not only traced the brown color of the *Salicornia* to an abundance of dead and dying plants, but found considerable corroborative evidence in the condition of other species living at slightly higher levels. On McKennan Island a similar condition was found. The island is girt by a zone of *Salicornia*, the outer or lower belt of which was found to be brown. A single measurement of the vertical range of dead and dying plants gave 10 inches.

The northeastern shore of the lagoon was examined for evidence of similar character, but the result was less satisfactory. The lowest plant growth is not everywhere the same and the local conditions are materially different. The slope is less gradual, the soil is more gravelly, and there is deposition of detritus eroded from the land by streams and waves. At some points a belt of plants at the extreme limit appeared to be suffer-



ing from some adverse condition, but elsewhere the normal green color was continued to the lowest limit. At the head of the lagoon and just to the east of the fault-trace is a considerable tract of *Salicornia*, of which the low-lying parts showed a brown color, but the distribution of vigorous and sickly plants was less simple than on the island and its causes were not fully understood. I afterwards visited the north slope of the spit to see if the condition of its vegetation corresponded to that on the islands, but found the evidence complicated by another factor. The overflow of the spit by waves during the past winter had washed a considerable amount of sand down the north slope, and this sand suffocated large tracts of *Salicornia* and other plants.

In the discussion of these data, the first point to be noted is that the killing of *Salicornia* thru the lower part of its zone definitely indicates a lowering of the ground on which it stands. The plant normally travels down the slope as far as it can tolerate the tidal submergence and there stops; and its inability to sustain itself in a well-defined belt constituting the lower part of its former range shows that the submergence in the belt has become intolerable. The amount of submergence is shown by observation on McKennan Island to be at least 10 inches, and if allowance is made for a certain amount of lag in the response of the plant to change of condition, the lowering of the land may have been several inches more than this. If McKennan Island and the eastern part of Pepper Island subsided the same amount, it is probable that the only change on Pepper Island was a subsidence of its eastern part, the western part remaining at its former level. In that case the amount appears sufficient to account for the overwashing of the spit, altho no measurement is there practicable.

The tract of land, whose subsidence appears to be demonstrated by the botanic evidence and the overtopping of the spit by waves, is bounded on the southwest by the fault, but its other limits are not known. In the immediate vicinity of the fault it may reach the head of the lagoon; that it does not extend beyond is rendered probable by the fact that there is no vertical dislocation in the fault-trace at a point about one mile northwest of the lagoon where the trace is favorably exposed on flat ground. It may be possible that the area of subsidence is limited on the northeast along an old line of dislocation which coincides approximately with the northeast side of the lagoon. This dislocation has not been determined by a study of the geologic structure, but is indicated by the physiography, and was presumably concerned in the making of the basin occupied by the lagoon.

The evidence of elevation west of the fault is less coherent. Dr. Southworth's observations on the clam patch give a presumption in favor of elevation, but they are not well supported by the evidence from barnacles and plants. The botanic evidence indicates that the entire dislocation shown by the measurement on Pepper Island is a subsidence on the east and does not include elevation on the west. The evidence from the barnacles suggests, without proving, a slight elevation at the Bolinas wharfs, but by no means indicates so great an elevation as would be necessary to account for the increased facility in reaching the clam patch. Dr. Gleason's report of the shoaling of water in a channel near Pepper Island undoubtedly shows a local change, but such a change may have been produced by a horizontal shifting of unconsolidated material such as occurred in Tomales Bay. On the other hand, it is not possible to explain the phenomena of the clam patch by a hypothesis of shifting bottom, for the sand in which the clams live is contained in shallow basins of visible bedrock, and any change in the relation of surface to tide at that point is a bedrock change. As the Rift belt with its numerous earlier dislocations extends nearly to the clam patch, it is not impossible that there were differential movements west of the fault-line and that the ground occupied by the clam patch and the abalone patch rose independently of the western division of Pepper Island.

*About Tomales Bay.* — Professors Kofoed<sup>3</sup>, Torrey, and Holway examined practically the whole shore of Tomales Bay, and also visited the outer or ocean side of Tomales Point. Their attention was directed especially to the condition of barnacles at the upper limit of the zone of marine life, and the evidence they found does not show any change in level, either by elevation or subsidence. It is their opinion that the injury to the clam industry along the northeastern shore of the bay is referable to other causes, including at some points the exceptional inwash of detrital material from the shore, and at others the shifting of loose material toward the center of the bay.

After the discovery of the vertical dislocation in Pepper Island, I visited the Papermill delta at the head of Tomales Bay in search of similar evidence of displacement, but failed to discover it. There are on the delta several tracts on which water stands after the fall of the tide, and the plant growth, especially *Salicornia*, shows deterioration in these areas; but the areas are not systematically related to the fault-trace. They occur on both sides and at least one of them is intersected by the trace. They constitute part of the evidence of a gentle, broad undulation of the delta surface, which appears to have been occasioned by the earthquake. A tentative theory to account for this undulation is that lenticular bodies of soft clay, included in the delta deposit, experienced a certain amount of flow during the earthquake period. The lane of water following the fault-trace, and described on an earlier page, is an independent phenomenon closely associated with the fault, and the depression causing it does not extend indefinitely toward the east. In a general way, the half of the delta east of the fault stands as high as the half at the west. On the lower slope of the delta, beyond the region of plant growth, there is a tract east of the fault which received the principal deposit of sediment brought by the floods of 1907. The localization of this deposit suggests that the transporting current may have been guided by a depression of the surface, but if so the depression was not bounded on the one side by the fault line; its southwestern boundary is a distributary of the creek. As the tract on which this deposit took place is opposite a portion of the tract in which mud was shifted toward the southwest shore, it seems possible that the area of shifting here included practically the whole width of the bay, and that the resulting elevation of the bottom toward the west was accompanied by a lowering of the bottom toward the east. In that case, the apparent lowering of the clam zone at various points on the northeast shore may be correlated with the phenomena near the head of the bay, and the whole ascribed to a general shifting of loose material in the bottom of the bay toward the west.

*Bodega Bay.* — As the title of Bodega Bay is variously applied on different maps, it is proper to specify that the body of water here intended is the land-locked lagoon east of Bodega Head, and not the open roadstead farther south. Professor Hitter examined this with care, studying especially the distribution of barnacles, and found no evidence of absolute or differential change of level.

*Summary.* — At Bolinas Lagoon, subsidence occurred east of the fault, its vertical amount being approximately a foot. The subsided tract included the greater part of the area of the lagoon, and may have had its eastern limit along the eastern shore of the lagoon. The subsidence was possibly a continuation of the local movement of dislocation by which the basin containing the lagoon was created. There may have been local elevation of a tract extending from Bolinas westward and northwestward. The evidence is not demonstrative, but leaves a presumption in favor of such elevation.

About Tomales Bay and Bodega Head there was probably no appreciable change in the general elevation of the land, most facts which tend to show such change being explained by assuming that in Tomales Bay there was a general shifting of mud and other incoherent material toward the west. Such shifting had been fully demonstrated in the vicinity of Inverness.

*Postscript.* — Since the preceding paragraphs were written, some additional data have been gathered bearing on the question of the elevation of land between Bolinas and Point Reyes. As the most satisfactory biological evidence with reference to changes in level had been found in the response of the plant *Salicornia*, it occurred to me that pertinent information might be obtained by examining the lower limit of land vegetation at Limantour Bay. That bay is an extensive, ramifying, drowned valley lying east of Point Reyes promontory. It is separated from the ocean by a spit, past the western end of which a channel is maintained by tidal currents, just as in the case of Bolinas Lagoon. The eastern end of the bay is at the western base of the ridge bounding the Bolinas-Tomales trough, and is 8 or 10 miles northwest of the abalone locality.

If the land in this locality was raised at the time of the earthquake, the height of the tide at all stages, with reference to the land, would be lower; and the lower limit of *Salicornia*, being dependent on the relation of the land to tide water, would descend the slope in response to the change in level. The feature, therefore, to be looked for was a new growth of *Salicornia* at a lower level than the older growth. Such new growth was actually found (June 5, 1907), not in a continuous belt, but in numerous patches having certain common characteristics.

At the points visited the tide marsh characteristically ends in a little step or bluff about 8 inches high. Above this step the gentle slope is covered by a mat of vegetation in healthy condition, the dominant plant near the step being *Salicornia*. Below the step is a mud surface, which usually inclines more rapidly than the platform above. If I understand the origin of this topography, the step has arisen from the gradual bayward extension of the platform, which, by reason of its vegetal covering, is enabled to arrest mud suspended in the water. There is also doubtless an accumulation of the roots and stems of the *Salicornia*. In places there are outlying platforms of the nature of islands and similarly covered by *Salicornia*. On the other hand, the broader platforms are interrupted by channels thru which the tidal waters escape, and there are also lake-like hollows abruptly margined by steps a few inches high. The slope below the step is ordinarily of bare mud, but on it are numerous patches of young *Salicornia*, and there are similar tracts in tidal channels and in some of the lake-like hollows inside the platform. The vertical range of this young growth is quite definite, its lower limit being from 13 to 16 inches below the outer edge of the platform. In some cases the young growth is straggling, but usually it makes a mat as close and complete as on the platform above, and the height is nearly as great. It is distinguished from the older growth chiefly by a slight difference in color. Whether such a luxuriant and dense growth of *Salicornia* could be produced in the period of 13.5 months, I am not prepared to say. Except for that doubt, however, the phenomena are just such as would be expected to follow an elevation of the land.

In an estuary at the edge of the bay were two fence stakes on which barnacles were set. At the upper limit of the barnacles, I examined a dozen individuals, finding them all alive, and I saw none of the adherent plates which remain after the death of the old barnacles. I did not learn the history of these stakes. If placed after the earthquake, the evidence of the barnacles would not be in point. If placed before the earthquake, the evidence of the barnacles, so far as it goes, is opposed to that of the new colonies of *Salicornia*.

*Second Postscript, added to proof sheets in November, 1907.* — Early in October, 1907, Dr. S. S. Southworth reported that the clam patch near Bolinas had again become less accessible, its relation to tides being practically as before the earthquake. The apparent change was not associated with any precise date, but it had been suspected since the middle of summer. On October 17 I visited the locality, selecting a time when the predicted sea-level at low tide was approximately the same as on November 25, 1900, when I had taken the photographs reproduced in plate 56B and plate 56c.

For November 25, 1906, the predicted height of low-water at the San Francisco entrance was 2.1 feet; for October 17, 1907, 2.2 feet. The comparison of the clam patch with the view made eleven months earlier showed a marked difference, a much larger area being submerged at the later date. Four days afterward, when the predicted height of low-water was 0.3 foot, I again compared the appearance of the clam patch with the photograph, finding the water-stage somewhat lower than when the photograph was made. As the tide rose its stage was found to coincide with that shown by the photograph one hour after low-water, and the calculated allowance for the corresponding change in water-level at the San Francisco entrance is about 0.3 foot, so that the predicted tide-stage for that moment was 0.6 foot. As the predicted stage at the time represented by the photograph was 2.1 feet, there was an apparent discrepancy of 1.5 feet. If this was occasioned by a change in the height of the ground at the clam patch, then there was a subsidence of 1.5 feet between November 25, 1906, and October 21, 1907. Before accepting so important a conclusion it should be checked in every practicable way, and especially by comparing the water-stages at the clam patch with simultaneous water-stages as recorded at the tide-gage station of the U. S. Coast Survey in the entrance to San Francisco Bay. The distance of that station from the clam patch is about 15 miles, of which one mile is inside the narrowest constriction of the Golden Gate. On the days of observation at the clam patch the sea was calm, except for a moderate groundswell, so that the normal equilibrium of the water-surface between that point and the tide-gage was presumably not impaired by meteorologic influences. Off the clam patch the groundswell broke at a distance from the shore, leaving the water so quiet at its actual margin that its level could be observed with little error. The general and local conditions were thus favorable for a comparison of water-stages at the two points; and the numerous details of the photograph of November 25, 1906, made it possible to identify, with close approximation, the arrival of the tide at the same plane on October 21, 1907. The observations at the tidal station, for which I am indebted to Capt. Aug. F. Rodgers, Assistant U. S. Coast Survey, were made with the tide-staff at low-water, and are referred to the arbitrary zero of the tidal station.

	FEET
At low-water on the afternoon of Nov. 25, 1906, the tide-staff reading was . . . . .	6.10
At low-water on the afternoon of Oct. 21, 1907, the tide-staff reading was . . . . .	5.61
In the hour following low-water the computed rise of the tide was 0.3 ft.; and this gives as the height of water at the time of the observation at the clam patch . . . . .	5.91
Difference . . . . .	<u>.19</u>

Thus the discrepancy of 1.5 feet, deduced from a consideration of the predicted tides, is reduced by a comparison of the observed tides to about 0.2 foot, a quantity so small as to be referable to errors of observation.

Before tide-gage records were obtained I had revisited Pepper Island and Limantour Bay. On Pepper Island the vertical dislocation was remeasured and found to be unchanged. At Limantour Bay the subject of examination was the condition of the new growth of *Salicornia*. If the land had subsided since the preceding June, the colonies of *Salicornia* which had invaded the mud flat (plate 56D) would have been subjected to unfavorable conditions, and might be expected to show the influence of those conditions. All the colonies that had previously been observed were reexamined and they were found, without exception, to have deteriorated. The green heads, which had formerly testified to their lusty growth, had become much less numerous and were modified in color; their stems were blackened on the surface and had become somewhat curled, and in general they appeared less healthy than the plants of the same species growing at higher levels. Where the slope was continuous, there was a fairly sharp line of separation between the healthy and unhealthy plants, and two measurements indicated the zone of impairment to have a vertical range of 10 inches.

The comparative observations of water-stages show that the land at the locality of the clam patch has not recently undergone the suspected depression, as compared to land at the tidal station near San Francisco. If an important change has taken place at one locality, it has affected the other also. On the other hand, it is noteworthy that Dr. Southworth's observations at the clam patch (first of its increased accessibility, and after of its decreased accessibility) led to two predictions as to the condition of *Salicornia* in Limantour Bay, both of which were verified. Their success in prediction gives assurance that they record an actual change of some sort — a change not restricted to the locality of the clam patch. The two lines of evidence taken together — the leveling by water-plane from the tide-gage to Bolinas, and the observation of shore conditions at Bolinas and Limantour Bay — suggest the possibility of a general change in the relation of land to sea, affecting the whole coast from San Francisco to Limantour Bay. So far as the observations go, such a change might pertain to either land or sea. In the line of this suggestion it is to be noted that November 25, 1906, falls within a period of exceptionally low tides at San Francisco entrance. For 21 low tides, from November 20 to November 30, the mean of the observed heights was 1.08 feet below the mean of the predicted heights. From October 17 to October 21, 1907, on the other hand, the mean of 10 observed tides was only 0.32 foot below the corresponding mean of predicted tides. The subject appears to deserve further investigation and discussion than is practicable while these pages are in press.

The observations which occasioned this postscript, while suggesting lines of enquiry which may profitably be followed, do not materially affect the conclusion already summarized as to local changes in the elevation of the land. A tract, including the east part of Pepper Island and much of the area of Bolinas Lagoon, subsided at the time of the earthquake, the amount of subsidence at the point of most satisfactory measurement being 12 inches. The region west of the fault, including the ocean coast from a point near Bolinas to Limantour Bay, may or may not have been uplifted at the same time, and may or may not have subsequently subsided. The evidence is incomplete and apparently somewhat conflicting.

Special reports on the biologic evidence follow.

## REPORT ON A BIOLOGICAL RECONNAISSANCE OF BODEGA BAY REGION.

BY WILLIAM E. RITTEK.

Accompanied by Mr. E. L. Michael, I examined the Bodega Bay region on October 26-30, for evidences of a faunal modification resulting from the earthquake of April 18, 1906.

My first effort was to secure information from residents of the district bearing on the question. A number of families living on the shores of Bodega Bay have their dwellings close to the water's edge. Since the bay is small, closely land-locked, and hence especially free from surf, and since these families spend much time on the water with their small boats, which they beach on the gradually shelving shores or tie to their little private piers, it seemed that their testimony would be peculiarly reliable. It appeared that any appreciable change of level of the water along the shore or any noticeable effects on the shore life would hardly escape detection. I talked with five persons of this sort, each by himself. All were unequivocal in affirming that neither the level of the water nor the animal life of the bay were in any wise altered by the earthquake.

The earthquake fault at the only point at which it has been located here, passes thru the sand-dunes at the head of the bay; and from its general course and the place where next observed to the south, must have past nearly parallel with the eastern shore of the bay and either have followed the shore or have been to the landward of the shore. In other words, nearly if not the whole of the bay, together with the peninsula of which Bodega Head is a part, is on the west or seaward side of the fault. All the facts we were able to gather by direct observation pertain to the rocky shore of the bay side of the peninsula. Since the rock here is a firm granite, and since in some localities the walls are nearly perpendicular, are even-faced, and are washed by the waters thruout the day excepting at extreme low tide, they are very favorable for furnishing testimony of the kind sought. The question to be answered was: Do the organisms that live immovably fixed to the rocks show evidence of having either extended or withdrawn the upper limit of their vertical distribution within recent time? The organisms that would be available as testimony would be those that are most permanent in structure, and extend up to the very limit of the high tide. Of first importance are the barnacles, two species, *Balanus balanoides* and *Chthamalus stellatus*. A species of *Mytilus*, and perhaps one or two species of marine algae, are also more or less available. Our attention was given to the barnacles chiefly, but somewhat to the mussels also. Neither of us was sufficiently familiar with the algae to make much use of them.

We could get no evidence that any of these organisms had either extended or withdrawn their limits of distribution. In the absence of accurate knowledge on the rate with which barnacles develop, there might be some uncertainty as to whether the limits had been extended; since, however, the individuals at the upper limit were not found to be in general smaller than those farther down; and further, and still more importantly, since the remains of dead individuals were quite as numerous proportionally in the upper zone of distribution as in the lower, we could but conclude that there was an absence of evidence of extension. In other words, there was no evidence of subsidence of the shore.

As to the question of whether the shore has been elevated at this point, the evidence I think is more positive. Not only is there lack of proof that elevation has occurred, but there is ample proof that it has not. This is furnished by the barnacles chiefly. On the vertical granite walls above mentioned, these organisms almost completely cover the surface up to about 7 feet above mean low water. As already stated, the remains of dead individuals are uniformly distributed thruout the area; or, to speak more accurately, they are not more numerous proportionally in the upper limit of distribution than in any other portion, as would surely be the case had the upper limit been lifted above the former high-water mark. It should have been pointed out that the 7 feet to which the barnacles extend must be very near, if not quite the limit, of high tide.

^ The character of the remains of dead animals is such as to preclude, I believe, being misled by the facts. In addition to the heavy calcareous wall which characterizes the superstructure of the animal, there is a well-defined continuous platform closely fused to the substratum to which the animal adheres. After death the superstructure of the shell falls away, leaving the platform as a smooth, hard, calcareous scab clinging to the rock. This is very durable, as one can see by observing old piles that have been taken from the water and to which these barnacle remains cling. Had any appreciable elevation of this shore occurred, there would surely be a zone of dead barnacle shells at the upper range of the distribution. The testimony of the mussels, so far as it goes, is confirmatory of that furnished by the barnacles.

## REPORT ON A BIOLOGICAL RECONNAISSANCE OF TOMALES BAY REGION.

BY CHARLES A. KOFOID.

On October 26-28, 1906, in company with Profs. H. B. Torrey and R. S. Holway, I made an examination of the shore of Tomales Bay to obtain evidence of faunal modification resulting from the earthquake of April 18, 1906. The places specially examined were as follows: the northeast shore from Millerton to Preston Point; Hog Island near the mouth of the bay; the southwest shore from near Tomales Point to the region opposite Marshall, and from Inverness to the head of the bay. The outer face of Tomales Point was also explored for a short distance near "Shell Beach."

Search was made for evidence of a change in level in the two sides of the bay and especially for evidence of depression of the northeast shore and elevation of the southwest shore. For this purpose critical examination was made of barnacles *in situ* on rock in place along the shores between tide levels. The fauna of the bay includes no generally distributed organisms attached to rock within tide levels except the barnacles (*Balanus* sp.). Mussels are rare and there are very few attached seaweeds far from the mouth of the bay.

The barnacles are, however, sufficiently abundant and widely distributed to afford an excellent index to any recent change in levels. If the northwest shore line, about 0.5 to 1.5 miles from the main earthquake trace, had been depressed even a few inches we might expect to find young barnacles, the young of the year which are easily distinguished by their brownish-gray color, softer texture of the shell, and certain structural features, invading the new territory above the old to an extent equivalent to the depression. If the southwest shore had been elevated, we should expect to find a number of dead barnacles in the region above the old barnacle limit and a relative absence of young in the upper levels. The upper limit of the growth of barnacles lies below the level of highest tides, and is more or less distinctly marked, according to the exposure to prevalent currents and wind and to exposure to the sun; and it is also modified by the slope and texture of the substratum.

The two shores present strong contrasts in the matter of exposure to prevalent winds, to the sunshine and in the texture of the substratum, the rocks of the northeast shore belonging to the Franciscan, more or less metamorphosed, and those of the southwest shore being of a granitic nature. These contrasts produce considerable modifications in the distribution of the barnacles.

A critical examination of the data reveals *no conclusive evidence of any recent change in the distribution of barnacles that can be attributed to a change in the levels of rocks in place.* There is no sharp and uniform contrast between the two sides of the bay in the matter of the distribution of these organisms. There is no uniform or extensive invasion of higher levels by young barnacles on the northeastern shore and no marked destruction of old barnacles and absence of the young at high levels on the southwestern shore. The conclusion is reasonably certain that there has been no appreciable change in levels of either shore as a whole.

Especial care was taken with the examination of the rocky shores of Preston Point which is crossed by the main fault, but even here there is no biological evidence of a change in levels on the two sides. In many regions barnacles have been killed in great numbers, apparently by silt in the waters. In other cases barnacle-coated substrata have been shifted with the mud, sand or gravel in or on which they lie, but such changes are of a local or superficial character. Hog Island, which lies very near the line of the fault but is not crossed by it, shows no uniform change in its barnacle fauna. The outer sea-cliff of Tomales Point, though very much shattered and with considerable talus from rock falls resulting from the earthquake, shows no disturbances in its fauna traceable to seismic movement. Local testimony of dealers in fish, of fishermen and of clam diggers indicates a great falling off in shipment of clams since the earthquake, traceable to departure of clam diggers, destruction of clams in places, by shifting of clam beds or their burial with detritus from cliffs. No change of levels which might not be traceable to shifting of loose deposits was noted.

There was local testimony of increased wash along the railroad embankment skirting the northeastern shore, or sinking or rising of known shoals in the bay, and of a depression of the gravel spit on which the fishing village stands. Probably all of these phenomena are explicable as the results of local loosening up of the railroad embankment and shifting of loose deposits, rather than as a result of a general movement of the earth's crust.

REPORT ON A BIOLOGICAL EXAMINATION OF THE BOLINAS LAGOON REGION,  
NOVEMBER 24-25, 1906.

BY CHARLES A. KOFOID.

*Bolinas Lagoon.* —The distribution of barnacles along the shore, on the piles, etc., was examined with reference to possible changes in level, near Bolinas wharf on the western side of the lagoon and on Morse's wharf on the eastern side, the principal locations on which barnacles occur about the bay. In neither case was there evidence or local testimony of disturbance in levels of the ground on which the barnacle-bearing substrata were located. The possibility of local slumping of soil is not, however, entirely excluded. No barnacles on rock in place were observed in the bay.

There is no evidence from the distribution of barnacles of any change in level of the eastern side of the bay. There is neither any marked destruction of old or absence of young in the upper levels such as would follow elevation, nor any marked recent occupation of an upper belt by young barnacles such as would follow depression. On the western side of the bay, on the piles of the warehouses at the landing, there was a faintly defined zone 6 to 8 inches wide in which the proportion of dead barnacles was unusually large. The percentage of dead in the uppermost levels on Morse's pier on the eastern side of the bay varied from 2 to 35 per cent with predominant range of 10 to 20 per cent. On the piles on the western side at similar levels, the proportion of dead was predominantly 40 to 60 per cent and not infrequently ran above these figures. Below this upper belt there was frequently less destruction and a relatively greater number of young than was found in the uppermost levels. It may be that this destruction was due to elevation, tho the uppermost belt of barnacles is still just submerged at a 5.4-foot tide. It might also be due to the considerable increase of silt attendant upon the large amount of talus shaken into the bay and along the adjacent shore line by the earthquake. The fact that barnacles attached themselves to and thrived on buildings thrown into the bay not far from the piles in question, would indicate that destruction by silt was confined to the time of the earthquake or that destruction did not take place as a result of silt.

The "studio building" at Bolinas, which was thrown into the bay by the earthquake and raised some months later, was well covered on submerged portions by barnacles, mainly half or two-thirds grown. This fact makes it certain that the young barnacles have been attached in large numbers since the earthquake, and that their distribution, therefore, affords critical evidence of change in levels.

*The Sea Coast Line.* — The evidence here from the distribution of barnacles is inconclusive, owing to the great range of movement of water in the breakers and the relative scarcity and small size of the barnacles present. There was no evidence of any change of levels, but their numbers are probably too small to afford evidence of a movement of a few feet only.

*The Clam Patch.* — The evidence of elevation here is entirely in the nature of testimony. The barnacles on rock in place in this region are too near the low-tide level to afford a satisfactory criterion. A few rocks in place near the upper levels show no trace of extensive destruction of barnacles such as might follow an elevation of 1.2 feet which Dr. Southworth believes to have taken place. But here again the biological evidence is too incomplete to have much weight. There is no doubt that there were clams in a shallow gravel bed resting on rock in place and abundantly exposed at a 2.1-foot tide.

In my opinion, from the evidence in hand, there was no depression of the eastern margin of Bolinas Lagoon as the result of the earthquake of April 18, 1906. Dr. Southworth's testimony, taken in conjunction with the destruction of barnacles in the upper levels on the western side of the bay, suggests the possibility of a small elevation on that side.



## EXTRACT FROM REPORT ON A RECONNAISSANCE OF TOMALES BAY REGION.

BY R. S. HOLWAY.

Below is a copy of the few notes made by me during the trip to Tomales Bay, October 26-28, 1906. The object of the trip was to examine the shore lines of the bay for indications of recent changes in level as shown by the effects on animal life. Drs. Kofoid and Torrey, the biologists of the party, recorded observations in detail and I have merely the general note as follows:

"The upper limit of barnacles was found to be a quite sharply defined line on the rocky shores of the bay. Any recent change in level of a foot or more would have been easily detected in *my* judgment. No evidence of such change was found. . . ."

## REPORT ON AN EXAMINATION OF PLANTS ON PEPPER ISLAND, BOLINAS LAGOON, APRIL 9, 1907.

BY WILLIS L. JEPSON.

*Salicornia ambigua* Michx. Pickle-weed. — This is the most abundant species and forms extensive colonies on both sides of the fault-trace. The difference in color of the areas on the two sides of the trace at once strikes the eye, the east area being dull or dead brown, the area west a livelier or greenish brown. This difference in color was found to be correlated with a difference in health. The plants west of the fault are in normal condition; the plants east of it are either dead or dying. Dead plants still standing show wasted or shrunken black stems. Dying plants show shrunken main axes bearing above a few short joints of green which are very much thicker than the main axis. In the normal plant the joints are no thicker or scarcely thicker than the main axis. A broad and very marked zone of dead or dying *Salicornia* surrounds McKennan Island which lies east of the fault.

*Statice Limonium* L. var. *californica* Gray. Sea Lavender. — Rather common in small areas on both sides of fault-trace. West of the fault plants are in normal condition, with large bright green leaves. East of the fault plants are dead or unhappy. Dead plants consist of nothing but caudices or short branching stems which form miniature forests of black stumps in the lowest places. Unhappy plants are those struggling to maintain existence and showing only a small tuft of small leaves. Similar colonies of dead plants were found on McKennan Island.

*Grindelia cuneifolia* Nutt. Marsh Grindelia. — The majority of the plants east of the fault are dead. Many plants west of the fault are dead, especially immediately west of the fault. The dying out is, in the main, doubtless due to old age in the colony.

*Mesembryanthemum cequilaterale* Haworth. Sea Fig. — Plants immediately west of the fault were healthy. One plant was found immediately east of the fault; this was killed completely.

*Distichlis spicata* (L.). Salt-grass. — Plants west of fault were thriving more than plants east in adjacent areas. (This species ranges to 600 feet above the sea.)

*Frankenia grandifolia* C. and S. Yerba Reuma. — Similar slight differences as in the preceding case.

*Triglochin maritima* L. Arrow-grass. — Coming up freely like young blades of grass west of the fault. Not appearing at all or reluctantly on east side.

*Jaumea carnosa* Gray. Fleshy Jaumea. — Less readily found on the east side of the fault. Plants on the west side were in somewhat better condition.

*Populus* species. Planted. — All individuals on east side of fault were dead.

*Summary.* — The difference in the health of the plants east and west of fault-trace indicates comparatively recent changes in conditions and would be explained by the assumption that there had been a change of level east of the fault. If there has been no such change it would be difficult to say why the affected areas should conform closely to the fault-trace. The plants on McKennan Island were also examined. The argument in favor of assuming a depression for Pepper Island east of the fault would hold good for McKennan Island. On the other hand, I should be strongly against the opinion that the condition of shore-line plants indicated a change in level on the east shore of Bolinas Lagoon.

## MUSSEL ROCK TO CRYSTAL SPRINGS LAKE.

*Course of the fault-trace.* — The point at which the fault-trace intersects the shore, on emerging from the ocean on the south side of the Golden Gate, is only approximately known. About 0.875 mile to the southeast of Mussel Rock, it has been located with precision at its intersection with the wagon road on the west side of the coastal ridge a little below its crest, and thence followed continuously for many miles. Projecting its course, there determined, in a northwesterly direction, it would pass out to sea in the midst of the large landslide which scars the coast immediately to the north of Mussel Rock, where the basal beds of the Merced series rest upon the older rocks. At the time of the earthquake there was an extensive movement of the landslide, and a tongue of landslide material, about 50 feet high and about 200 feet wide, was projected into the ocean across the narrow strip of beach.<sup>1</sup> This movement naturally obscured all evidence of the position of the fault-trace, which was doubtless overridden by the slide. All about the crest to the east of the landslide, and on its south side, the ground was greatly disturbed by fresh landslide cracks, scarps, and fissures, extending well back from the edge of its encircling cliffs. It appears to be probable that not only did the movement of the landslide obscure the evidence of the fault-trace, but also that the latter was here diffuse and scattered, and that the displacement was superficially taken up by the plasticity of the landslide material.

From the point southeast of the Mussel Rock slide where the fault-trace resumes its definite and easily recognizable character, to Crystal Springs Lake, our information regarding the course of the fault-trace and the earth movement on the fault is in part from observations made by Mr. Robert Anderson, and in part from observations recorded in a paper by Herman Schussler,<sup>2</sup> supplemented by the observations of Mr. H. O. Wood, Andrew G. Lawson, and others.

South of the road, at a point 0.875 mile southeast of Mussel Rock, begins the furrow which marks the surface path of the fault. The furrow as such does not cross the road to the north of this point. The side-hill slope, however, is very much fissured by landslide movements both above and below the road, and scarps are seen. From this point, the furrow runs uninterruptedly southeastward to the east side of the north end of San Andreas Lake, where, with a course of about S. 33° E., it passes beneath the waters of that reservoir. As it approaches the lake, the trace of the fault does not lie in the axis of the valley, but runs along its eastern side. It thence passes thru the lake on the north-east side, crossing a number of small promontories, to the east end of San Andreas dam; thence, with a course of S. 37° E., it traverses the east side of the valley between this dam and Lower Crystal Springs Lake, passes thru the latter and intersects the old dam between Upper and Lower Crystal Springs Lakes. Beyond this it skirts the southwest side of the upper lake, partly in the water and partly on the projecting points, and finally leaves the lake about a 0.25 mile from its end, for the stage of the water of April, 1906, having here a course of S. 40° E.

The mean course of the fault, as thus closely followed from the vicinity of Mussel Rock to the end of Upper Crystal Springs Lake, a distance of about 15 miles, is S. 36° 30' E. But the trace is not a perfectly straight line. Between Mussel Rock and San Andreas

<sup>1</sup> According to the observations of Mr. H. O. Wood, this projecting tongue of landslide had been entirely removed by the action of the waves, and alinement of the beach and sea-cliff had been reestablished.

<sup>2</sup> The Water Supply of San Francisco before, during, and after the Earthquake of April 18, 1906, and the Subsequent Conflagration. New York, 1906.

dam, the trace of the fault is slightly concave to the straight line connecting these two points on the fault, the concavity being to the southwest. Between San Andreas dam and the end of Upper Crystal Springs Lake, the trace of the fault is again slightly concave to the straight line between these points, but is on the opposite side of the fault, the concavity here facing the northeast.

*Characteristics of the fault-trace.* — For this stretch of from 14 to 15 miles, Mr. Robert Anderson, who examined this territory under direction of Prof. J. C. Branner, describes the trace of the fault as marked by a belt of upturned earth resembling a gigantic mole-track. The rupture may be traced along every foot of the way when not below the waters of the lakes. It varies in width from 2 or 3 feet to 10 feet, but at times branches out into several furrows that include a space of 100 feet or more in width. Such branches sometimes join again after a short interval. Sometimes it forms a crack 2 or 3 feet wide and several feet deep, and in other places shows a vertical wall of soil on one side or the other, several feet high. The typical occurrence in turf-covered fields is a long, straight, raised line of blocks of sod broken loose and partly overturned. It is thus shown in plate 61A,B.

Associated with the fault fractures are many lateral cracks, extending away from the fault in a northward, or north slightly eastward, direction; that is, at an oblique angle to the northeast side. These cracks were especially abundant along the northeast side of the northern half of Crystal Springs Lake, and between there and San Andreas Lake. In places they run off every foot or few feet for a distance of 100 yards or more, and again they do not form for some distance. They vary in size from minute crevices in the earth to fractures a foot or more in width. Here and there they form lines of broken sod very like the main furrow in size, while they have a length of from a few feet to several hundred feet. At the great dam at the head of San Mateo Canyon, these cracks emerged from the lake and ran northward up on the hills for several hundred yards, breaking the fences where they crost. Plate 16A shows large lateral cracks of this description, already partly filled up, crossing a road that runs parallel to the fault at the upper end of Crystal Springs Lake. The main line of fracture is about 50 feet beyond the fence, and the cracks extend into the foreground at an angle of from  $35^{\circ}$  to  $40^{\circ}$  with the main fault-trace. The fence is pulled apart 40 inches in the two places which are shown in the photograph, and a total of 10 feet in ten different breaks in this locality, within a distance of 200 yards. Such lateral cracks as these were not noted on the southwest side of the fault.

The lateral cracks described above make an angle of  $45^{\circ}$  to the general line of the fault fracture. They appear to have been produced very much like the fracture lines in compression tests of building stones. There was evidently great pressure holding together the two faces along the fracture. A dam made of earth and rock divides Crystal Springs Lake into two parts. This dam crosses the fault-trace at right angles, and was offset but not badly cracked or injured by the movement. The fences that line the road were warped and their boards buckled thruout the distance across the dam. The earthquake rendered them too long for the distance from the hills on one side of the valley to those on the other. The inference is that a strong compression took place. The slicken-siding shown in plate 62A furnishes further evidence of compression. In the same way the heaving up of the sod into a long, raised mound, for most of the extent of the furrow, suggests lateral pressure. The formation of cracks a few inches to 2 or 3 feet wide in places along the furrow seems to contradict the theory of compression; but these are regarded as due to the irregular, crooked fracturing of the surface and the faulting of irregularities into juxtaposition with one another near the surface. The open cracks

were never found to be of great extent, but were usually followed by stretches along which the earth was heaped up into a mound, as if by being prest together. The surface furrow indicates that there was a zone of crushing some 2 or 3 or more feet wide. Where a similar cross-section of the fault is viewed from the opposite direction, no such face is exhibited on the northeast side, but instead a mass of crushed earth projecting beyond its former position.

*Offsets of fences, pipes, dams, etc.* — About a mile southeast from the point near Mussel Rock where the furrow was first noted as a clearly defined feature, the fault-trace passes thru the trough of a well-marked saddle. This feature is more accentuated than similar features at other points along this portion of the rift, tho many such are found. Southeast from this saddle there is recognizable in the topography a distinct line of former movement, lying east of the fault. No furrow follows the line continuously, but an occasional

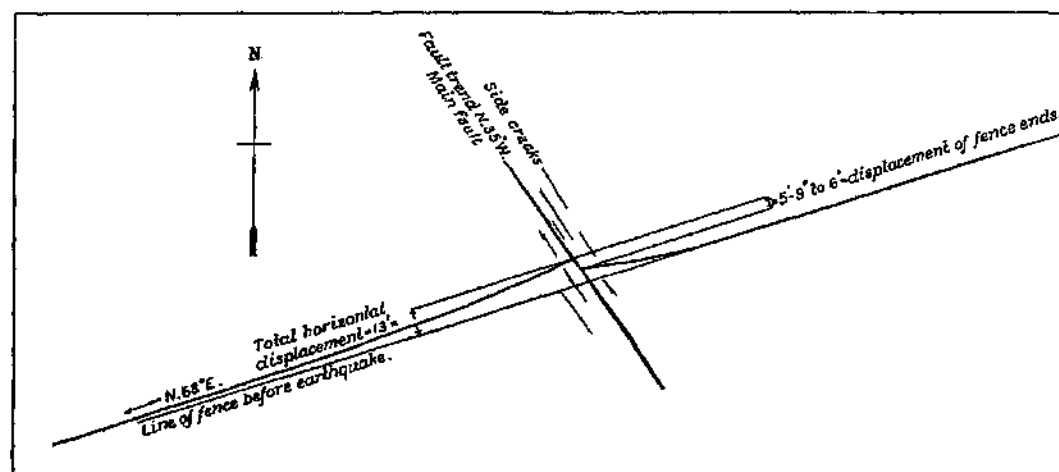

FIG. 29. — Offset fence southeast of Mussel Rock, showing distribution of deformation on either side of fault.

short fissure or crack runs along it for a little way. To the west of the place is a similar, but less well marked, topographic indication of a former movement. There is no evidence of any movement on this line at the time of the earthquake. At the point where the fault-trace crosses the road, less than half a mile farther on, the roadway and fence were broken, but the effects were so confused that the measure of the offset could not be determined. The apparent horizontal displacement was slight.

Still farther to the southeast, about 1.25 miles, the fault intersected a fence and not only caused it to be offset, but the intersection showed clearly the effect of the drag in the earth movement. The bearing of the fence is N. 68° E., so that it is approximately transverse to the line of the fault. On the west side of the latter, the fence suffered a displacement to the northwest of 13 feet from its former position, and this displacement was effected by a bending or curvature in the fence line extending westerly from the fault for a distance of over 200 feet. On the east side of the fault, the fence was bent away from its former position, *in the same direction*, about 7 or 7.25 feet, the bent portion extending easterly from the fault-trace about 45 feet. The two ends of the fence were thus offset on the line of the fault only 5.75 to 6 feet, altho the total displacement was 13 feet. The displacement is shown diagrammatically in fig. 29. At a point 330 yards beyond this, on the Rift, the fault-trace was found to be confined to a furrow about 6 feet wide, passing thru a little trough between an outcrop of Franciscan on the west and a fine conglomerate (Merced) on the east.

Nowhere along this portion of the fault-trace between the slide at Mussel Rock and San Andreas Lake was there observed any definite evidence of vertical displacement. There was a hint of slight upthrow on the western side, but it could not be tested by measurement. There were, in general, furrows on either side of the main fault, at various distances up to 200 feet. Some of these were persistent for considerable distances.

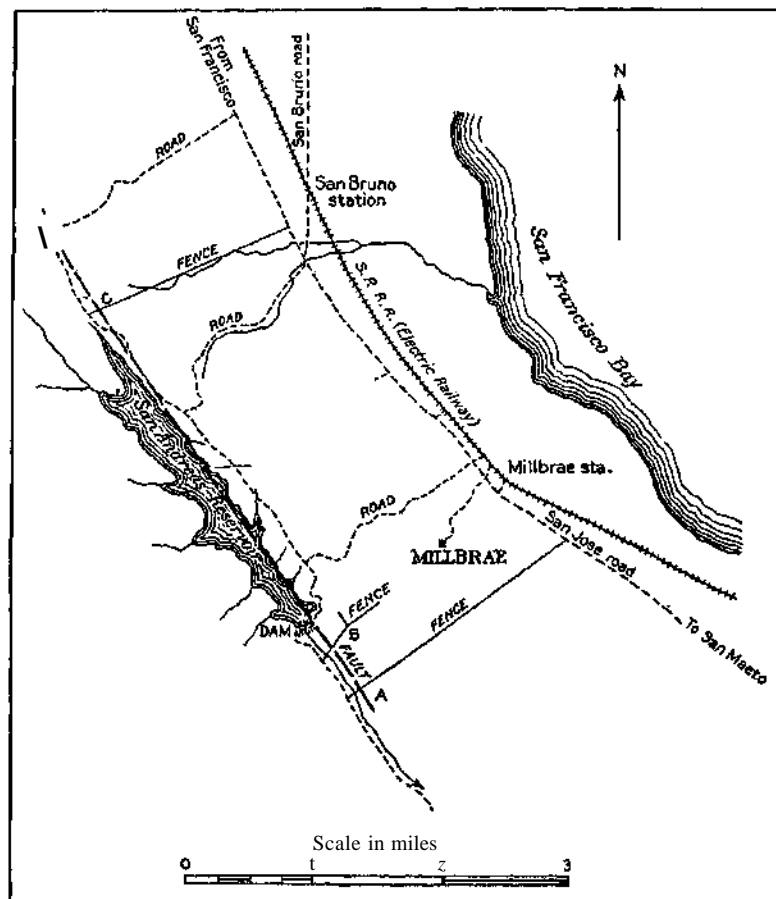

FIG. 30.—Index map showing positions of three fences, A, B, and C, the offsets of which are shown in figs. 31, 37, and 38.

About 2 miles from the upper end of San Andreas Lake the fault encounters the 30-inch, laminated, wrought-iron pipe of the Spring Valley Water Company, which prior to the earthquake conveyed the water from Pilarcitos Lake to San Francisco. The metal of the pipe is about 0.1875 inch thick and coated with asphaltum. The pipe is buried in the soil at a depth of 3 to 4 feet. The point of intersection is near Small Frawley Canyon. Here the course of the pipe swings from a northwesterly to a more northerly course, and the fault consequently intersects it at an acute angle. At the point of intersection, the pipe was obliquely sheared apart and telescoped upon itself, effecting a shortening of about 6 feet. The amount of the transverse offset involved in the shear was about half the diameter of the pipe. The portion north of the break was moved east and telescoped southerly. For 0.875 mile southeast of this point, the path of the fault lay on the northeast side of the pipe and nearly parallel to it, but a short distance away. About 220 yards southeast of the intersection, where the pipe, buried a few feet below the surface, ascends a rising slope, the pipe had completely collapsed for a distance of several

yards, due doubtless to the establishment of a partial vacuum within the pipe by the sudden withdrawal of the water from the arch in the pipe at the time of the shock, owing either to the leakage below, or the propulsion of the water induced by the shock. (See plate 60B.)

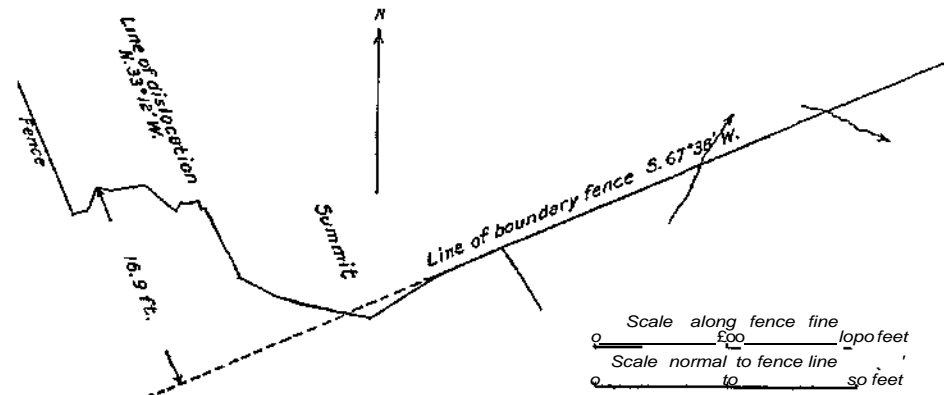

FIG. 31.—Fence C of fig. 30.

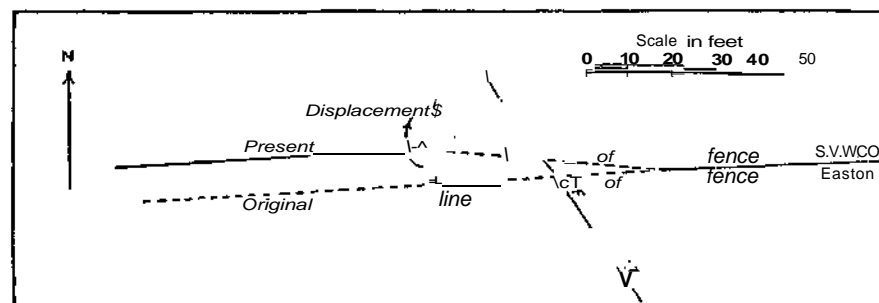

FIG. 32.—Dislocation of fence near San Andreas Lake. After H. Schiussler.

At a point about a mile from the upper end of San Andreas Lake, the fault intersects a bend in the pipe at two places, and here again the pipe was telescoped. (See plate 60A.) The conditions at one of these intersections are thus described by Mr. Robert Anderson:

The pipe makes an angle of about  $15^\circ$  with the fault-trace, the end of the pipe on the north side of the fault running that much nearer the north. The ends of the pipe on opposite sides of the fracture were therefore thrust into each other. The furrow was at this place divided into several smaller ones, the disturbed zone covering an area of considerable width. The pipe was broken in three places within 100 feet. In one place it was telescoped 58 inches, as shown in plate 59B; in another 17 inches, and in a third, the one farthest north, 41 inches.

Near the head of the lake, the pipe was again intersected by the fault, with results described by Mr. Anderson as follows:

The pipe line runs almost parallel with the fracture, but slightly more to the west at this point, so that the acute angles made by the ends of the pipe with the furrow were in this case on opposite sides of the furrow to those in the two previous instances. In other words, the southeast end of the pipe was farther to the east than the southeast end of the

furrow. The movement was in the same direction as before, therefore a pulling apart of the pipe took place instead of a compression. There occurred two breaks in the pipe (see plate 59A), the main one at the crossing of the fault, and the other 150 yards away on the northeast side of the fault, but very near it, the pipe being almost parallel with it. At the main break, the pipe was pulled apart 59 inches, and at the other one 21.5 inches, making a total displacement of 6.666 feet. The pipe was not quite parallel with the fault and therefore there was a slight offset, at right angles to its direction, of 4 inches at the main break and 2 inches at the minor one, or a total of 6 inches. A fence which crossed the fault at the main break is offset 6.5 feet. (Plate 60c.)

The index map, fig. 30 (p. 95), indicates the position of three dislocated fences which were surveyed by R. B. Symington, C.E. The fences are marked A, B, C. One of these fences, C, near the upper end of San Andreas Lake, is nearly normal to the trace of the fault, and its deformation extends over a zone 1,200 feet wide, the total displacement aggregating 16.9 feet. Here, as usual, the portion on the southwest side of the fault moved relatively to the northwest, but there was a distinct drag on the northeast side in the same direction. (See fig. 31.)

The offsets in three other fences southeast of San Andreas Lake are shown in figs. 32, 33, and 34 and plates 60D and 61B.

Thruout this 2-mile stretch within which the pipe line nearly parallels the fault-trace, the path of the latter is strongly marked by a prominent furrow in the sod, with the usual diagonal cracks and variable width. This furrow lies on the northeast side of the

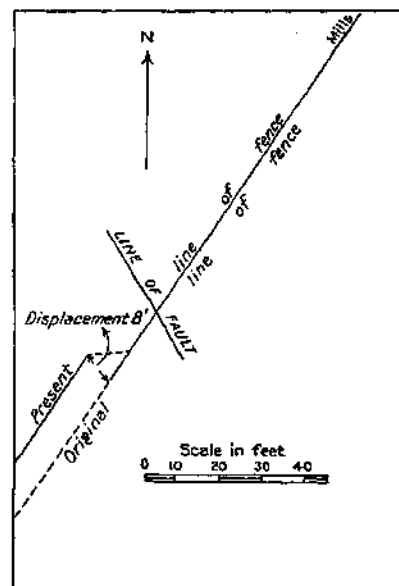

FIG. 33.—Dislocation of fence near San Andreas Lake. After H. Schussler.

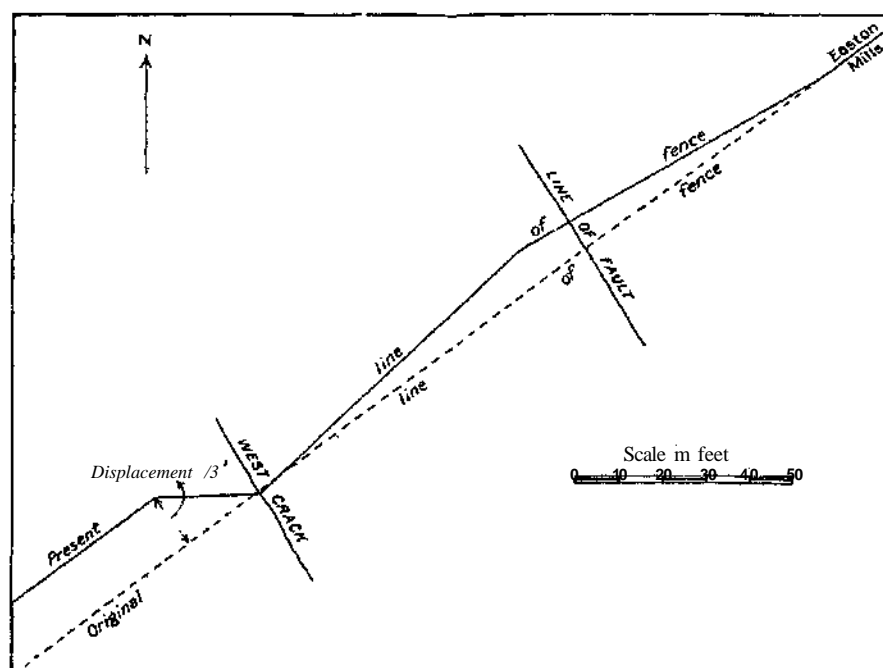

FIG. 34.—Dislocation of fence near San Andreas Lake. After H. Schussler.

lake for the first 0.875 of a mile of its length. It then enters the water (plate 61D) and follows the northeast side of the lake, a little distance from shore, to the San Andreas dam at the lower end of the lake. In this distance of nearly 2 miles, the fault-trace emerges from the water at a number of points where little capes project into the lake. The crossing of these capes by the fault-trace indicates that it follows a very straight course beneath the water of the lake. On the last of these promontories traversed by the fault, the main fault-trace has associated with it a number of auxiliary cracks. Between the main fault-trace and one of the diverging cracks, on the southwest side of the fault, is a brick and cement gate-well in connection with the tunnel which takes the waters from the lake toward Millbrae. This gate-well was circular in cross-section, the inside diameter being about 26 feet. The nearest point of the structure to the main fault-trace is within 5 feet.

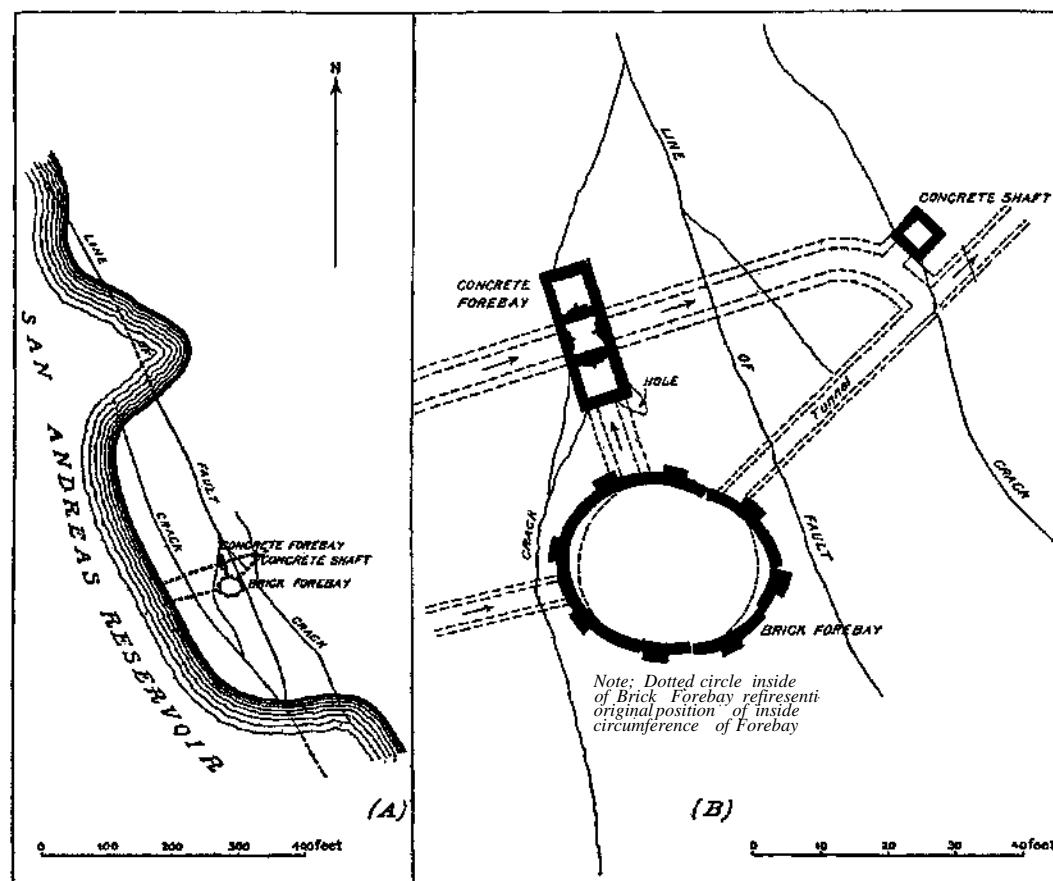

FIG. 35. — Main and auxiliary faults, San Andreas Lake. A. General Plan. B. Detail. After H. Schussier.

The walls are about a foot thick, and are strongly buttressed. As a result of the shock this gate-well was shattered and deformed so that it became oval in cross-section, the east and west diameter becoming 30 feet and the north and south diameter about 21 or 22 feet, as shown in the accompanying figure. A new concrete gate-well a few feet to the north, rectangular in cross-section and having three compartments, each 2.5 x 2.5 feet, was uninjured, altho on the line of the same branching crack. A concrete manhole 45 feet northeast of the damaged gate-well, also on an auxiliary crack, was similarly unaffected, (See fig. 35.)



At the San Andreas dam, the fault past through a rocky knoll which serves as an abutment for the dam on both sides, the embankment being in 2 parts. The rocks were shattered and the road over the dam and the fence paralleling it were offset several feet in the usual direction. The ground here was traversed by several cracks, those on the south-

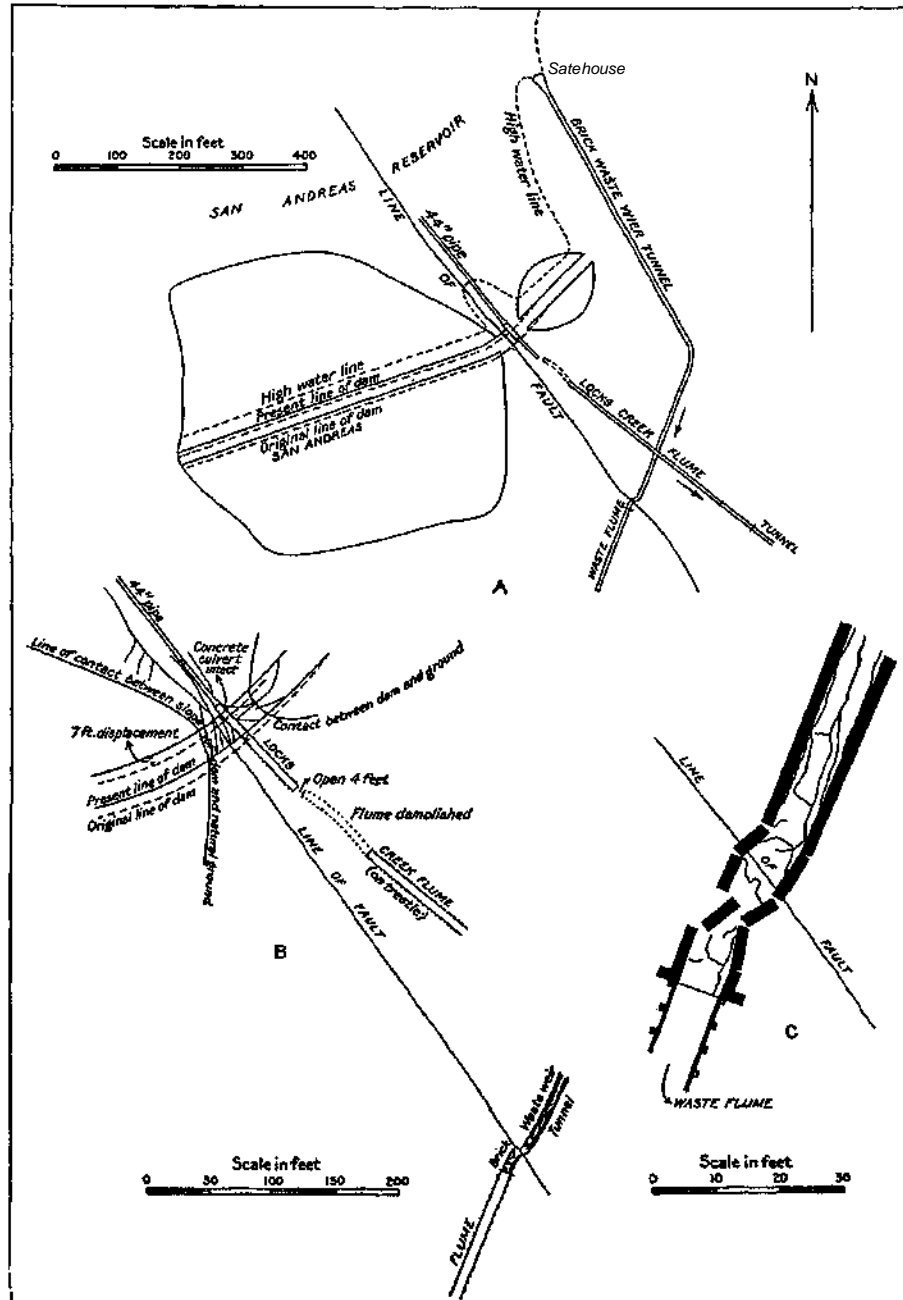

FIG. 3.— Intersection of San Andreas dam by fault. A. Plan of dam in two parts, with rock between. B. Relation of dam to waste weir tunnel. C. Detail of waste weir tunnel.

west side of the fault branching southerly from it and those on the northeast side branching northerly. Below the dam a heavy wooden flume on a trestle within 50 feet of the fault-trace was demolished for about 60 feet of its length.

About 125 yards below the dam the fault past thru the lower end of a massively built brick and cement waste weir tunnel. The inside diameter of the tunnel was about 7 or 8 feet and the walls were 17 inches thick. At the intersection of the fault within this structure, the latter was stove in and smashed in pieces for a distance of about 28 feet. The tunnel was offset about 5 feet. In the shattering of the brick work, the cracks and ruptures in no case followed the cement between the bricks, but broke across the latter; the cement and its adhesion to the bricks being stronger than the bricks themselves, altho the bricks were evidently carefully selected and of good quality. Several cracks traversed the tunnel longitudinally and obliquely to the northeast of the part that was demolished. (See fig. 36.)

About 550 yards below the San Andreas dam, the fault-trace crost a boundary fence

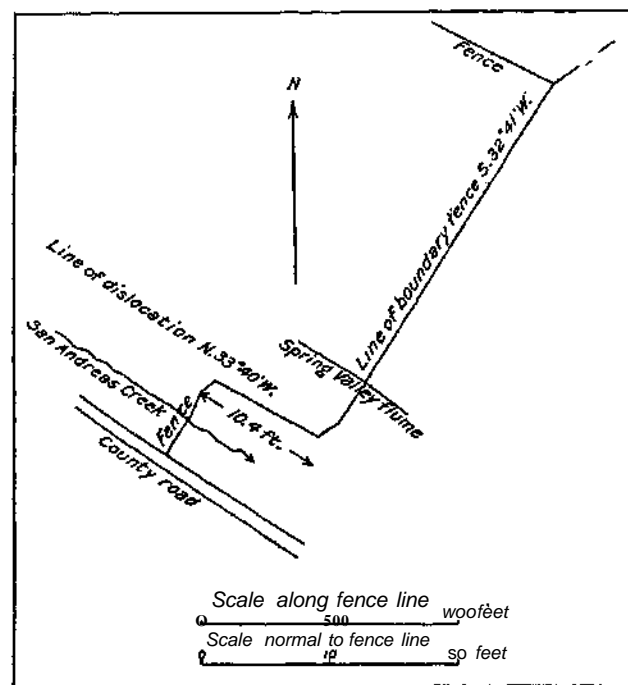

FIG. 37.—Fence B of fig. 30. Dislocated by fault.

between the estate of D. O. Mills and the property of the Spring Valley Water Company, causing an offset of about 10 feet. Here the deformation of the fence was distributed over a zone 300 feet wide in the direction of the fence, or about 250 feet in a direction normal to the trace of the fault. A survey of the dislocated fence made by R. B. Symington, C.E., is shown in fig. 37. Half a mile below the dam, the fault again crost the Pilarcitos pipe. A note by Mr. Anderson as to the conditions at this intersection is as follows :

It is a 2-foot pipe made of iron 1 inch thick. The fault broke it at an upward bend. An elbow at the bend was crushed by the compression and thrown down, while the two remaining ends were brought about 22 inches nearer together. At the same time they were faulted past each other a distance of 20 inches.

The pipe runs N. 25° E., making an angle of 65° with the fracture, which here runs N. 40° W. The telescoping at this angle, being 22 inches, represents 52 inches of faulting.

In this neighborhood the fault crost a wire fence nearly normally, the line of which had been carefully established by a series of stone monuments. The fence marks the boundary between the estates of D. O. Mills and A. M. Easton. The deformation of the fence as shown in the accompanying diagram, fig. 38, from a survey by R. B. Symington, C.E., extended over a zone at least 2,200 feet wide. On the southwest side of the fault-trace, the fence was displaced to the northwest a distance of 9.3 feet, and on the northeast side it was displaced to the southeast 3.4 feet, making a total displacement of 12.7 feet and showing a slight drag close to the line of the fault. There were two parallel cracks representing the fault about 90 feet apart, and the chief displacement took place on the west crack.

About 0.625 mile farther southeast, near the upper end of Crystal Springs Lake, the fault crost another fence showing a displacement of 9 feet. About 0.25 mile southeast of this place, the fault crost the Locks Creek 44-inch pipe line. Regarding this intersection Mr. Anderson writes:



A. Rupture of 30-inch water-pipe by fault. Northwest of San Andreas Lake, A. O. L.



B. Break of 30-inch water-pipe by fault, northwest of San Andreas Lake. Annotated by Meopig if 58 beta. A. O. L.

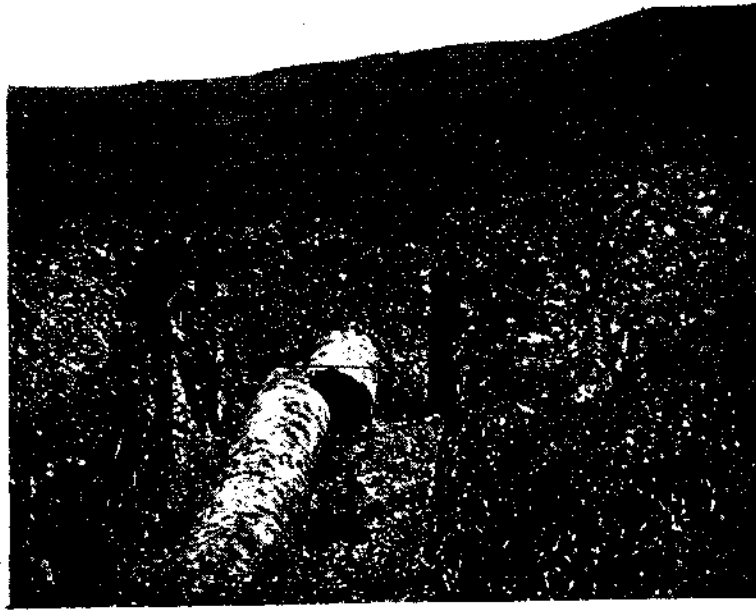

A. Offset in 30-inch water-pipe by fault. Northwest of San Andreas Lake. E. L. H.



B. Collapse of 30-inch water-pipe northwest of San Andreas Lake. E. L. H.

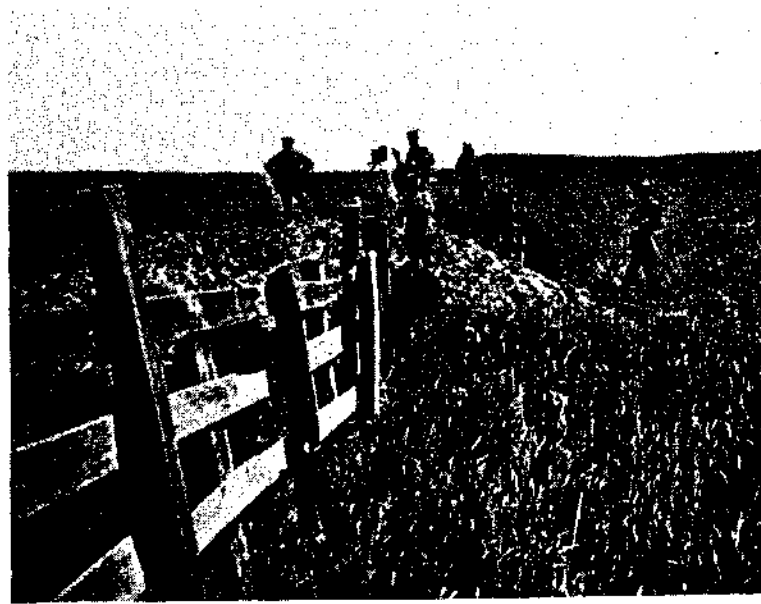

C. Offset of 6.5 feet in fence, northwest of San Andreas Lake. E. L. H.



D. Offset of 6 feet in fence between San Andreas and Crystal Springs Lakes. Per J. O.B.



A. Fault-trace where it passes into San Andieas Lake, D.



B, Ofikrtfitto\*WMurG;.!V7-:jfsLO». B. A.



A. Exposure of slickensided fault plane near north end of Crystal Springs Lake, E. A.



B. Offset of road by main fault near Seartrille reservoir. Per J. C. B.

Just above the northern end of Crystal Springs Lake, a 44-inch water main made of iron 0.125 inch thick runs up the hill from the lake valley in a direction about N. 28° E. This line is buried all the way under several feet of soil. The fault crosses it at the base of the hill, in its N. 37° W. course, thus making an acute angle of 65° with the pipe line. At the intersection of the fault and the pipe line, the heavy rivets of the pipe were torn out all the way around at a section joint and the two sections were jammed into one another a distance of 4 feet 4 inches. In addition to the telescoping of this pipe, a slight change in course was induced, so that the northeast end trended one or two degrees more toward the east than the other end. This was shown by the fact that the broken ends did not fit into each other squarely. There was no lateral displacement, the whole movement having been taken up by the telescoping, but there was a bending of the pipes at the point of the break, as mentioned. The main part of the pipe, at a distance from the fault, must have moved with the land. At the fault-trace there was a bend amounting to one or two degrees. Supposing the bowing to be simple, this amount indicated that the land must have carried the pipe the distance represented by the telescoping, or about 10 feet, within 300 to 500 feet

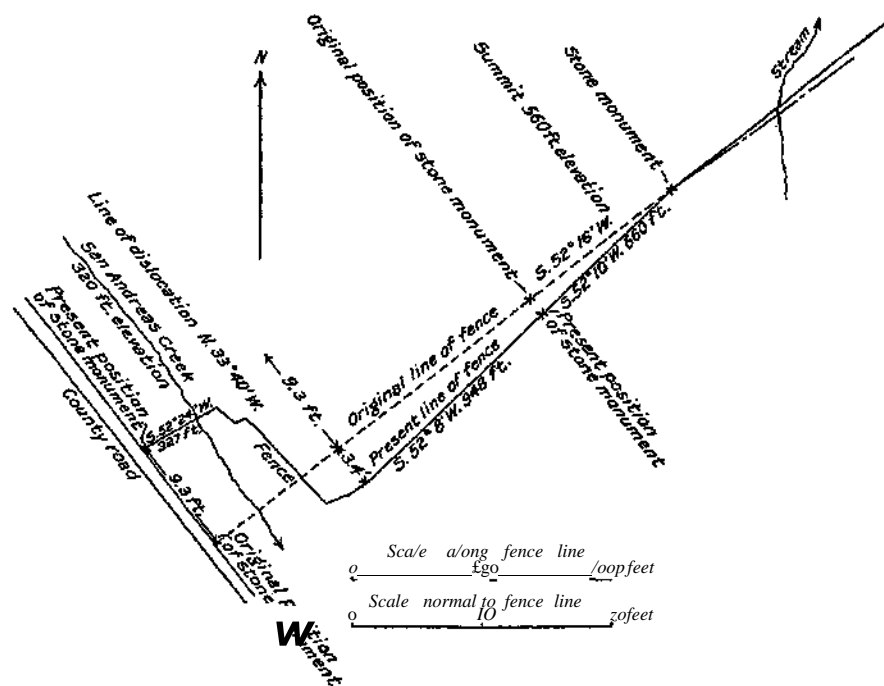

FIG. 38.—Fence A of fig. 30. Dislocated by fault.

of the fault on one side, and that beyond such a point the pipe must have preserved its normal course. As a matter of fact, this same pipe was broken on the northeast side of the fault about 400 feet further up the hill. The break occurred at the junction of 2 sections, the rivets having been sheared off and part of the rim torn away at the rivet holes. The ends were pulled apart 3.375 inches. Here the pipe resumed its former course, but owing to the slight amount of the pipe displayed by the excavation, it was impossible to see whether a return bend occurred or not. Beyond the break the direction was as before measured, approximately N. 28° E. No such break occurred on the southwest side of the fault. A crack was formed in the earth at right angles to the pipe for several yards on either side of the break.

The measurements of the engineers of the Spring Valley Water Company on the break and displacement of this pipe at the intersection above described by Mr. Anderson are given in the accompanying diagram, fig. 39.

About a mile southeast of the Locks Creek pipe line, the trace of the fault entered Crystal Springs Lake for the stage of water of April, 1906. At 2.5 miles farther

southeast, it crosses a small point projecting into the lake from the northeast side. Half a mile beyond it passes thru the dam between Upper and Lower Crystal Springs Lakes. This dam is now simply a causeway across the lake, the water on both sides standing at the same level. The dam was rendered superfluous except as a causeway by the construction of the great concrete dam at the outlet of the present Lower Crystal Springs Lake. The latter was uninjured by the earthquake, a careful examination having failed to reveal even a crack in the splendid structure.

Where the fault intersects the causeway dam between Upper and Lower Crystal Springs Lakes, the dam was dislocated and offset about 8 feet. (Fig. 40.) This displacement was well marked in the roadway across the dam and in the fences which parallel it. The fences on both sides of the road were broken and the boards were buckled and shoved over each other; the telephone wires crossing the lake sagged considerably, showing that the movement brought the poles closer together. The facts indicate, as previously stated, that, in addition to the offset of the dam along the line of the fault, there was a notable compression in the direction normal to it. Beyond this dam the trace of the fault is partly beneath the lake and partly skirts its southwest shore (for the water level of April, 1906), and finally leaves the lake on that side about 0.25 mile from its southeast end.

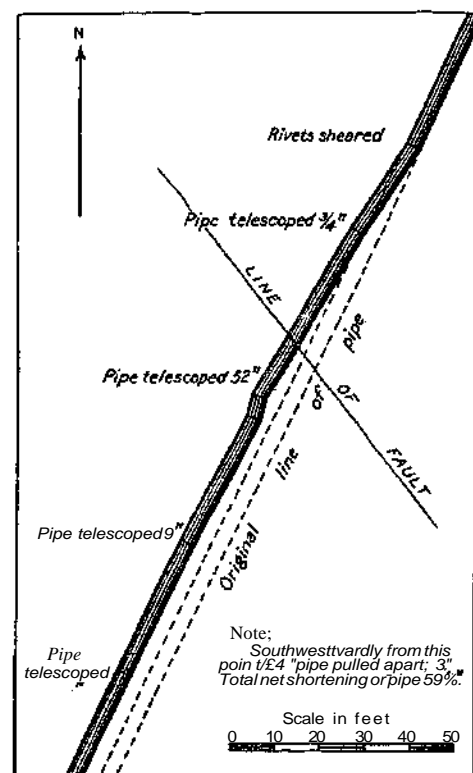

FIG. 39.—Intersection of fault and Locks Creek pipe. After H. Schussler.

relatively, leaving a portion of its lower slope in juxtaposition with the higher slope of the other side. A horizontal line across the exposed face would give the distance moved, provided no subsidence had taken place, which does not seem to have been the case. The distance could be only approximately measured, but it is at least 8 or 10 feet. A crack 2 to 3 feet wide and several feet deep separates the two walls locally. Looking at the oilier side of the same mound an irregular face several feet in height is exposed on the northeast side of the fault, the natural result of a longitudinal slipping. The faulting of raised surfaces after this fashion was discovered in various other instances. Large hills were crost only two or three times in this stretch of the fault. They were not so affected.

The banks of stream channels sometimes preserved evidence of the movement even more completely than did mounds. Almost every gully crost by the fracture suffered

considerably, showing that the movement brought the poles closer together. The facts indicate, as previously stated, that, in addition to the offset of the dam along the line of the fault, there was a notable compression in the direction normal to it. Beyond this dam the trace of the fault is partly beneath the lake and partly skirts its southwest shore (for the water level of April, 1906), and finally leaves the lake on that side about 0.25 mile from its southeast end.

*Exposures of the fault-plane* (R. Anderson). — In addition to the evidence given by fences and pipes, there is the displacement of land surfaces and actual exposures of the fault face at the surface. Examination of mounds, embankments, and shore lines crost by the rupture usually revealed a displacement of the surface, and an interruption of the old topographic outlines. In the case of mounds cut by the fracture, the displacement makes itself apparent in vertical scarps in consequence of the curved surfaces being faulted past each other. At the northwest face of a hillock, near where the furrow emerges from Crystal Springs Lake, the northeast side of the mound —the side away from the lake—has retreated



a disjoining, resulting in a narrowing and bending of the channel at one point. The banks on the northeast and southwest sides of the fault were thrust past each other southeast and northwest, respectively. Usually the movement resulted in the crushing of the loose earth at the surface, while the roots of plants tended to hold it in place, so that the displacement was not evident in its full effect. An example where this is well shown occurs in the channel of a small stream running at right angles to the fault valley just north of the north end of Crystal Springs Lake. The banks of the gully were about 20 feet high. Where the fault crosses the southeast bank, the parts on either side of the crack faulted past each other horizontally, the result being a relative displacement of the northeast side of the fracture at least 8 feet toward the southeast. There is no vertical movement apparent. An escarpment is left exposed on the southwest side of the fault from top to bottom of the embankment. The material of the bank, plastic, argillaceous earth derived from weathered shale, was slightly moist at the time. The fault planes are closely apprest and the clay was left slicken-sided and lined with distinct horizontal striations. (Plate 62A.) The opposite bank of the stream gives evidence of a similar movement, but the loose earth was held by large roots and the displacement of the underlying earth was obscured. The two projecting faces of the opposite banks almost met, making the channel very narrow and curved.<sup>1</sup>

A steep embankment of weathered serpentine and soil occurs at the southern end of San Andreas Lake, where it is crost by the fault. The zone of rupture is several feet in width and the broken material on the northeast side is shown projecting several feet beyond its previous position in continuity with the serpentine slope. A displacement of the shore line is observable at several places where the fault fissure enters the lake. Wherever cracks were opened, search was made for the disjoining of squirrel holes and other discrepancies due to shifting, but with rather unsatisfactory results. Roots, however, were found broken and displaced in accordance with the general movement as shown by other things. In general, the search for evidence in the separation of different zones of vegetation or of color in the earth, etc., failed to add anything of value to evidences of other kinds.

*Vertical movement* (R. Anderson). — No proof was found of a vertical movement along the fault line. Here and there occur small escarpments along the fissures, varying from a few inches to several feet in height. They were only local, however; they exhibited no constancy in the side of the fault upon which they appeared, and were invariably explainable either as fault exposuras such as are discust in the previous paragraphs, or as

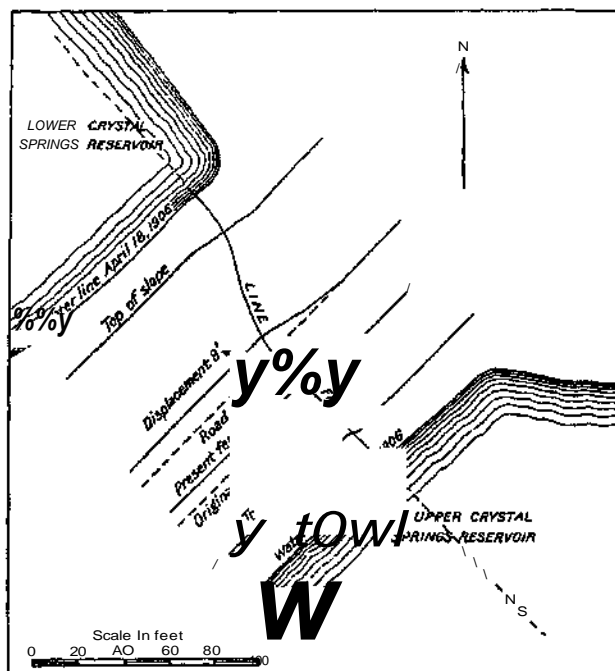

FIG. 40. — Map of fault-trace across old dam between Upper and Lower Crystal Springs Lakes. After H. Schussler.

<sup>1</sup> The writer is indebted to Mr. C. E. Durrell and Mr. F. D. Posey, of St. Matthews School, San Mateo, for the discovery of this interesting example of faulting.

due to settling of loosely accumulated or unsupported earth. For this reason no credence is given to the idea that an uplift or downthrow occurred along this part of the fault. This statement is based entirely on the evidence collected on the ground shortly after the earthquake and has nothing to do with the direction or amount of earlier displacement along this same fault-line. In some places an upward thrust seems to have taken place, as in the case of raising 7 pipes. This may, however, have been caused by wave-like movement in the ground near the surface or simply by the local heaving up of the ground as the result of compression.

#### CRYSTAL SPRINGS LAZE TO CONGRESS SPRINGS.

For our knowledge of the character and extent of the earth's movement on the fault for that portion of its course lying within the limits of the Santa Cruz quadrangle of the U. S. Geological Survey, or between Crystal Springs Lake and the vicinity of Congress Springs, we are indebted to observations made by Messrs. H. P. Gage, F. Lane, S. Taber, and B. Bryan, under the direction of Professor J. C. Branner. The notes of these gentlemen are preceded by a summary statement, and are arranged as far as possible in sequence from northwest to southeast in the following section:

*Summary statement* (J. C. Branner). — The fault-trace that follows the San Andreas Valley continues southeastward in a nearly straight line. Beyond Crystal Springs Lake, it passes thru the village of Woodside, the Portola Valley, crosses Black Mountain a mile southwest of the triangulation station, follows down the general course of Stevens Creek a distance of 5 miles, and thence, following the same general direction along the eastern slope of Castle Rock Ridge, passes off the eastern side of the Santa Cruz quadrangle near latitude  $37^{\circ} 10'$ . West of Stanford University it follows along the northeastern base of the mountains that lie between the Pacific Ocean and the Bay of San Francisco, but as it passes toward the southeast, it cuts into the range and leaves Black Mountain and Monte Bello Ridge on the northeast side, while south of Saratoga it keeps well within the mountains. A singular feature of the fault, as it appears at the surface, is that instead of following the bottoms of the valleys, it often skirts along the base of one of the enclosing ridges, as shown in the accompanying sections. (Fig. 41.) This is not an invariable rule, however.

It will be seen from the map/No. 22, of the isoseismal lines on the Santa Cruz quadrangle that there are several other faults within the area of the quadrangle, but evidences of movement at the time of the earthquake have been found only on this San Andreas fault-line, with the possible exception of slight movements along part of the Black Mountain fault. Cracks in the ground occur here and there almost all over the area covered by the sheet, but the cracks away from the San Andreas fault are due to incipient landslides or to the settling of loose or wet ground, and are not otherwise related to the more profound faults.

The movement that took place along the fault in this portion of its course at the time of the earthquake was almost entirely a horizontal one. At several places evidences were seen of vertical displacement, but further examination showed in many instances that the appearances were deceptive or due to local causes. For example, where the fault crosses the top of Black Mountain there was apparently an upthrust on the northeast side of the fault. But it was found later that a great wedge-shaped piece nearly half a mile across had settled on the southwest side of the fault, producing this appearance.

The direction of the horizontal displacement is uniformly a relative southeastward movement of the land on the northeast side of the fault. The amount of displacement varies in this area from near zero to 8.5 feet. This variation appears to be due to the character and condition of the ground. Usually ground that was wet and incoherent at

the time of the rupture yielded and was crushed so as to distribute the displacement through the surrounding soil. In such places, but little or no horizontal thrust appeared at the surface. Where the land was well drained and the surface materials were dry, the ground held together better except along the fracture itself, and the displacement was more apparent. It seems highly probable, however, that, owing to the deep decomposition of the rocks and the frequent movements and fractured condition of the beds along the fault, the maximum displacement does not appear at the surface anywhere within the area of the Santa Cruz quadrangle. Nowhere has the fracture been found passing through freshly broken beds; and in view of the antiquity of the fault itself, and the evidence of many movements upon it, such an exposure is not to be expected.

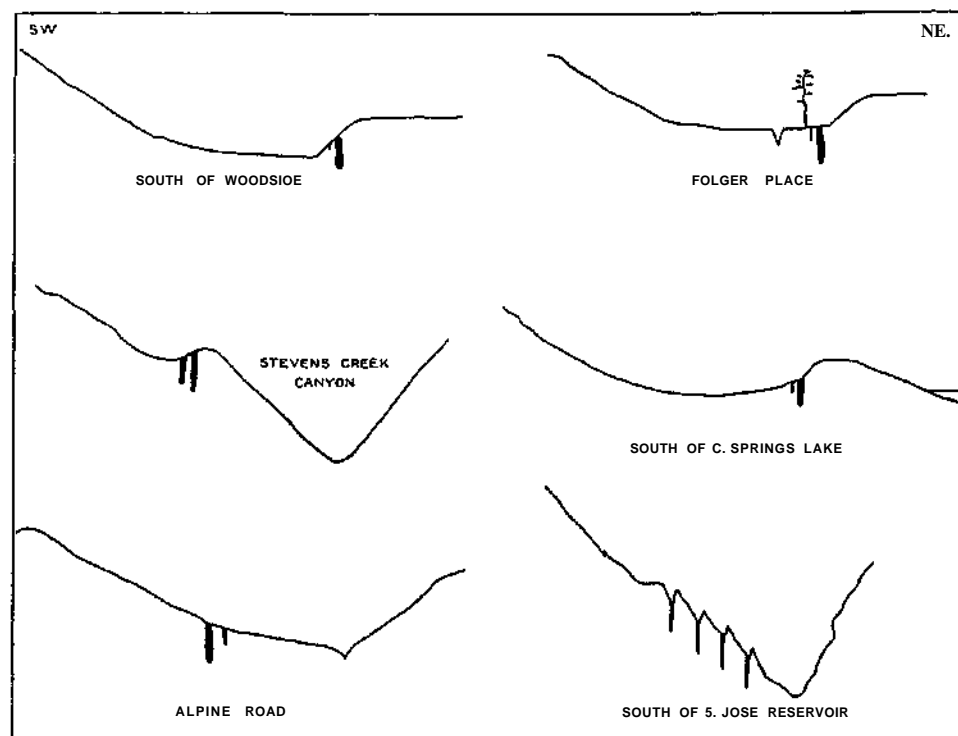

FIG. 41. —Profiles of Rift, showing relation of fault to slopes.

*Crystal Springs Lake to Portola.* — Southeast of the southern end of Crystal Springs Lake are numerous cracks along the line of the fault. One less than 0.5 mile from the southern end of the lake past directly under a house, the chimney of which had fallen, and the building had burned to the ground. (28, map 22.) About 100 feet southeast of the road near this house (29, map 22) a crack 1.5 feet wide in places runs approximately parallel to the road. The cracked belt adjoining is about 4 feet in width, the downthrow being about 6 inches on the northeast side, the lateral thrust about 1 foot on the same side, the northeast side moving southeast relative to the opposite side.

About a mile southeast of the lake are large cracks, running approximately north and south, in places 1.5 feet wide. At a point 2 miles southeast of the lake, a crack about a foot wide is crossed by a fence running N. 53° W. (27, map 22.) The top wire of this fence was broken by tension during the shock, and the post nearest the crack was snapped off at the ground, the adjoining post being uprooted, and bent over in the same direction as the broken one. The posts are of split wood about 5 inches in diameter, and the wires

are 2-strand barbed wire. This belt of cracks continues for about 300 yards along the road. Near Woodside there was a 2-inch crack trending northwest-southeast, with an upthrust of about 2 inches on the northeast side. A crack 1.5 feet wide in places runs N. 23° W. across the road, entering Woodside village from the southwest, just west of the bridge, and in places shows an upthrust of about 2 feet on the northeast side. A small tree on this crack was uprooted in the western part of the village. On the King's Mountain road, southeast of Woodside, a large crack of the main fault-trace crossed the road, and the fences on both sides were pulled apart. (See plate 62B.) NO vertical throw was observable. About 200 feet west of the fault fracture were several smaller cracks parallel to it.

Further southeast, down the road toward Portola, the main fault-trace crosses the road just north of the creek and within 12 feet of a giant redwood. The ground was raised and crumpled across the road, and the cracks extend both up and down the stream from this place. In a cluster of young redwoods southeast of this road a board fence is bent out of line, and huge cracks opened among the roots of the trees. A wire fence was pulled in two and one of the posts split. In this cluster of trees the fault passed thru and split a big redwood stump.

Two fences crossing the crack at right angles near 12 (map 22) had been thrown out of line, their northeast portions being moved southeast relative to their southwest portions. They had been given an offset of 8.5 and 8 feet respectively. (Plate 63B.) A large oak tree standing on the crack was uprooted, while branches were snapped on a big white oak tree just south of the fault line.

Northwest of Searsville Lake, about a mile, there is a belt of cracked ground 7 or 8 feet wide, one crack being 1 foot in width. The apparent upthrust was in some places 2 feet on the northeast side. At other places there is no change of level. On the Portola road, just southwest of the Searsville Lake, parallel cracks with a trend N. 43° W., some of them 1.5 feet wide, were formed across the road and extended into the marsh to the northwest and into the woods on the southeast. Where they crossed the road, the fence boards were broken and the earth shoved up in ridges; the northeast side of the crack moved southeastward.

The main fault fracture passes thru the Portola Valley and crosses the public road in front of a small 1-story house southeast of the village store. Where the fault crosses the road, the fences on both sides were torn in two, and in the prune orchard south of the road the rows of trees were displaced in some instances about 2 feet. The cracks in the road were about 6 inches wide, approximately parallel, and running nearly north-south, while the direction of the fault line itself was about northwest-southeast.

About a mile beyond Portola, a crack, measuring 2.5 feet in width in some places, crossed a field, the cracked ground spreading out for 10 feet at intervals. Wooden fences crossing it were broken, water pipes bent and pushed up to the surface of the ground, and a dead tree near the line of the crack was thrown down. There was an apparent upthrust of about 2 feet on its northeast side.

*Road from Judge Allen's southward.* — Between 3 and 4 miles southeast of Portola, many cracks were visible extending in all directions. Several showed an uplift on the east or northeast side, which is also the downhill side. Some cracks were from 4 to 5 inches wide, and had a vertical throw of nearly a foot. In other places the downhill side had been thrust upward, and pieces of the crust shoved as much as 4 inches over the uphill side. Near the top of the ridge, just before reaching the point where the trail branches off, a 4-inch crack running S. 63° E. showed a 4-inch upthrow on the northeast (downhill) side. Southwest of the ridge and about 100 feet below the trail, an old landslide dating back to some time within the past year, covers about 2 acres. Around this slide the ground appeared to have been much cracked recently.

Along this trail the direction of the cracks varied considerably. One an inch wide in places, elsewhere branching into several smaller ones, was traced for about 150 yards, chiefly along the crest of the ridge. Its direction varied from due east to southeast, and the upthrust on the west was sometimes as much as 3 feet. Going northwest down the crest of the ridge, numerous cracks crossed in directions varying from southeast-northwest to northeast-southwest, several showing an upthrust varying from a few inches to a foot on the southwest side. At the foot of the trail, a large crack running down the center of the valley followed the road for about 100 yards, then cut across the fields. In places the crack was 2 feet wide, but in other places a ridge 3 feet high had been raised beside the road, and there were many parallel cracks within 50 feet of either side. There were upthrusts and downthrows, some as much as 1.5 feet, but the total change of level seemed to be nil.

*Alpine road.* — A fault branches from the main San Andreas fault in the Portola Valley and crosses the Alpine road just where the Portola road leaves the latter. At this fork several cracks were formed at the time of the earthquake. A water pipe 2 inches in diameter was buckled and lifted out of the ground here, and farther along the Portola road this same pipe was pulled apart. Following southward along the Alpine road, the next evidence of disturbance by the earthquake was where the main fault-trace crosses the road 0.75 mile south of where the Portola road forks. Here the road was so badly broken and cracked that it was not possible to ride or drive across the fracture until the place was repaired. (Plate 63A.) The fracture followed along the south side of the road for a distance of 300 feet, tearing up the bank with cracks, some of which were a foot or more across. Where the road bends toward the south, the fracture crossed to the north side of the road, making cavities several feet deep. These cracks continued toward the northwest thru the underbrush, pulling apart a barbed wire fence and leaving many well-marked furrows thru the adjoining fields. About 30 feet north of the road, a white oak, somewhat weakened by decay and fire, was jerked off by the violence of the shock. To the southeast the fault-line is traceable by a well-marked furrow thrown up in the fields. Where the fracture crosses the Alpine road, there appears to have been an uplift of about 2 feet on the northeast side of the fault. This appearance may be due to the settling of a part of the ridge of incoherent materials to the south, or it may be due to the lateral thrust along a sloping surface.

*Black Mountain.* — The great mass of Black Mountain lies between the San Andreas fault and a branch fault (Black Mountain fault) which, starting in the Portola Valley, crosses the Page Mill road on the north side of the mountain about a mile south of Clarita vineyard. This area between the faults was badly shattered by the earthquake, tho it is not clear whether the abundant cracks found over the surface are to be attributed to the boldness of the topography or to the crushing of the wedge-shaped end of the fault block. Several days after the earthquake, 345 cracks, large and small, were counted along the county road (Page Mill) in a distance of less than 3 miles between these faults. These cracks ran in every direction, and some of them were clearly attributable to local topography, while others cut thru the mountains in apparent disregard of the topography.

The main fault-trace crosses the Page Mill road in a topographic saddle near three frame houses. The displacement occurred along two parallel and well-defined cracks some 30 feet apart. These cracks can be traced across the fields on both sides of the road. Toward the northwest they converge until they are only a few feet apart. Where they cross the road, the fracture was not a single clean-cut break, but made up of a series of small short cracks from 3 to 5 inches across, parallel with each other and "splintering" across the general direction of the fracture. The fences on both sides of the road were displaced about 3 feet, and there was an apparent drop of 18 inches on the southwest side of the fault. The horizontal displacement showed the northeast side to have moved

relatively toward the southeast. The apparent vertical displacement seems to be deceptive, or rather, it appears to be due to the settling of a wedge-shaped mass on the southwest side of the fault. The south side of this mass was indicated by a crack about 300 yards farther south along the road where a crack showed a drop of several inches on the northeast side. On the Monte Bello Ridge, a mile southeast of the Black Mountain triangulation station, there were a few inconspicuous cracks, without any uniformity of direction. Just south of the triangulation station, the cracks were more conspicuous; one of them was 200 feet long, and had a bearing of N. 13° W. At and about Hidden Villa, a small ranch in the deep valley 2 miles northwest of Black Mountain triangulation station, there were no cracks in the low ground, even where they were expected, as this is on the line of the Black Mountain fault that crosses this region from the direction of Portola.

*Page Mill road.* — In following the Page Mill road up Corde Madera Creek from Mayfield, the first noticeable trace of the earthquake was a crack crossing the road due east and west, its width varying from 0.5 to 1 inch. Wagon-tracks showed a lateral displacement of 1 inch, the north side of the crack having moved west, relatively to its south side. This crack was traced a short distance into the fields beside the road, where it disappeared. Several smaller cross-cracks intersected it at intervals. There was no apparent vertical displacement. About 100 yards farther south were 3 smaller cracks varying from 0.25 to 0.75 inch in width. One ran N. 53° W., and another N. 23° W. The latter, being only 8 feet from a culvert crossing under the road, appears to have been deflected by this from a course running more nearly east. Here again was no evidence of vertical throw. Going on up toward the Alpine road from this point, more and more cracks were found, running approximately east and west, with the exception of several north and south ones where the road ran closely parallel to the stream. Less than a mile from the first crack, groups of cracks were accompanied by small slides of dirt from the hill to the west of the road, and farther on from the bluff to the east of it. The cracks ran nearly parallel with the axis of the branch-valley lying northeast and southwest. Farther up the road, large cracks began to appear among smaller ones running parallel. The first of these was 2.5 inches across and ran S. 13° E., with a downthrow of 1 inch on the east side, and could be traced from 50 to 100 feet on either side of the road. For a mile farther up the road, the cracks became so numerous and complicated that it was impossible to map any individual ones. They intersected and ran in all directions, and were all of varying widths, the largest seen measuring 8 inches across. The size of this crack, however, was probably partly due to its position on the side of a hill. The larger cracks could be traced for several hundred feet. In some places crushing had taken place, and the layer of macadam on the road had been humped up and broken. In this same area are many small landslides, some large enough to cover the road; one has occurred since the earthquake.

*Stevens Creek.* — Following the road from the junction of the Castle Rock Ridge road with the road from Stevens Creek to Boulder Creek toward Stevens Creek, small cracks appeared crossing the road in a direction of N. 1° E. Further east nearer Stevens Creek, the road was badly broken up by the land sliding in two directions, N. 18° W. and N. 47° E. All along this region cracks varying from a fraction of an inch to 2 inches in width, and running from N. 43° W. to due north and south, appear every 10 feet or more, showing a badly broken-up area. Here and there such cracks resulted in landslides from the bank to the road. A crack about 2 inches wide ran N. 53° W. for some distance above the house, at the junction with the Stevens Creek road. On the Stevens Creek road, just after leaving the Saratoga road, there were cracks every 20 or 30 feet, running in the same direction, about N. 43° W. A mile and a half northwest of the place where Stevens Creek turns northeast, a strip of ground 2 feet in width and about 100 yards long had been broken up, with a downthrow of about 6 inches on the west side. The cracks ran N.



A. Offset of Alpine road 5 miles west of Staaford University. Per J. O. B.



B. Offset of Alpine road 5 miles west of Staaford University. Per J. G. B.

43° W. From here northwest the disturbance continues in the same general direction. A number of breaks often occurred together, arranged as steps, in each case the downthrow being on the east side and measuring about 4 inches, the direction varying from N. 33° W. to N. 3° W. Following the Stevens Creek road on down toward Congress Springs, several landslides were noted, mostly small ones due to caving in of the banks of the creek. Just west of the springs the road was badly broken, twisted, and shoved up in places, the downthrow being first on one side and then on the other. In some places along the bank the west side projected 2 inches farther than the other, while the fence showed an offset of 2 feet. The large stone bridge across the creek appeared intact, but west of it a large patch of ground had slipped down 2 feet.

*South of Congress Springs.* — Near and northwest of the reservoir 2.5 miles southeast of Congress Springs, fissures from 4 to 6 feet wide ran nearly north and south, and past through the earthen dam at the northwest end of the reservoir. (Plate 64A.) The intake pipes at the south end of the reservoir were disconnected, and the escaping water undermined a part of the southern dam of the reservoir. This reservoir is in a topographic saddle and has dams at both ends. The fault-trace passes through this saddle. Where the bottom of the reservoir was exposed by the escape of the water, cracks of the fault-trace were exposed in the mud. Fences crossing the fissures showed but little displacement; the displacement moved the northeast side toward the southeast, relatively. The hills southeast of the reservoir have steep slopes of from 20 to 50 degrees. The cracks follow the east-facing slopes and the east side of these cracks had raised about 6 or 8 inches. Southeast of the reservoir the chimneys and water-tanks were down.

#### CONGRESS SPRINGS TO SAN JUAN.

Mr. G. A. Waring, under the direction of Prof. J. C. Branner, studied the displacement along the fault from the vicinity of Congress Springs to its southern end near San Juan. The following is an account of the phenomena observed by him:

*Cracks and displacements along the fault-trace* (G. A. Waring). — Starting at the upper reservoir about 2 miles south of Congress Springs, the fault-trace was followed to its southern end near San Juan. From the upper reservoir, through which the fault passes, cracking the dams at each end, a fairly continuous series of cracks a few inches wide runs down the southwest side of Lyndon Creek about 2 miles to Mr. Edwards' place, "Glendora." Throughout this distance the individual cracks run S. 3° to 13° E., while the line as a whole trends S. 33° E. The relative movement of the northeast side of the fault is from 14 to 20 inches southeast. From Glendora the fractured zone becomes wider and not so distinct. The lower reservoir is slightly cracked and several fissures appear near it, but the main line of fracture seems to be nearly 0.5 mile west of it, showing in two or three cultivated fields. The whole ridge west of the reservoirs was severely shaken, however, for cracks 4 or 5 inches wide opened near Grizzly Rock and several large slides occurred in its neighborhood. One water-pipe running north and south on the Beatty place was broken, while one trending east and west was unhurt. No cracks were found crossing the ridge between Grizzly Rock and White Rock. The cracks were next found on the road about a mile east of B. M. 2135 of the U. S. Geological Survey, but they do not show in the vineyard to the southeast. On the ridge road, about 5 miles northwest of Wright Station, the fault again shows slightly in a few 2-inch cracks bearing S. 3° E., with a slight relative movement of the east side toward the north. Going down the slope from here to Wright, the cracks rapidly become larger.

At Patchin, 3 miles west of Wright Station, there are fissures over a foot wide trending mainly in the direct line of the fault (S. 33° E.). Several stretches of numerous small



cracks alternating with a few long, continuous fissures, mark the course from Patchin to Wright Station. Thru the Morrell ranch it is especially evident. (See plate 64B.) At Wright Station the movement is well shown in the railway tunnel. (Fig. 42.) This tunnel runs southwest, and about 400 feet in from the eastern end of it there is a nearly vertical slicken-sided plane, showing a shear movement of 5 feet. Apparently the southwest side moved northwestward. Between Wright and Alma, the railway track was badly bent in places (see plate 107A), but the ground did not crack noticeably. It seems to have been subjected to compression, for 7 inches had to be cut from the rails when the track was repaired. A large landslide also occurred close to Wright Station, partly damming up the stream. The fault past a little west of Wright, tearing up the public road at several places (plate 65A), especially at the blacksmith shop, near Burrell Schoolhouse. Sulfurous fumes are said to have risen from this crack for several hours. From this place the cracks run up over the ridge just west of Skyland. Large fissures show in the orchards and fields on the eastern side of the ridge, but are not so evident on the western slope. Here, instead, great landslides occurred, and redwoods were snapped off or uprooted. Thru the timbered region from Skyland to Aptos Creek, the course of the fault-trace is marked almost its entire length by a swath of felled trees, true fault fissures being found at only two places. On the northern side of Bridge Creek Canyon there are typical cracks from 1 to 8 inches wide, and here also occurred a great landslide which buried the Loma Prieta Mill. The second place where fault fractures are found is on the ridge between Bridge and Aptos Creeks, where there are well-defined fissures up to 18 inches in width, trending S. 3° E., with a downthrow of the western (upper) side of from 2 to 6 feet, and a relative movement of the east side a few inches toward the south. The cracked zone is about 50 feet wide. Great slides on both sides of Aptos Creek have almost made a valley of the canyon for fully 0.75 mile. Following across the ridges and canyons, the discontinuous line of slides and sinks in upland marshy places marks the course of the fault-line down into the lowland.

The road at Corralitos is said to have been slightly cracked, and in the low hills between Valencia and Corralitos a few cracks were found; but the fault evidently runs fully 0.5 mile east of Corralitos. The mountain roads east and northeast of Corralitos were rendered impassable by landslides and by the bridges being injured. Crossing the road near Hazel Dell Creek is a band of small cracks 35 yards wide, trending S. 3° E. The fence on either side is not displaced, but the posts lean 30° to the southwest. About 0.25 mile farther northeast the stake fence on the northwestern side of the road is moved 10 inches out of line, and the ground just beyond has sunk a few inches. The fissures appear to die out in the marshy land west of Wm. McGrath's house, and they begin again a mile eastward, halfway up the slope. Thru this upland meadow region is a series of slides and sinks gradually rising in elevation. At a small ravine, fissures again appear and follow up it (S. 33° E.) for 0.25 mile, mainly as a great furrow from 2 to 6 feet wide. Three ponds near the divide lie directly in its path, but the cracks are only a few inches wide here. Thru the grain fields beyond they are not very evident until at the divide between the steep slope to the Pajaro River and the gentle westward drainage. Several cracks a foot or less in width show on the ridge, but the fault seems to set off about 100 yards to the northeast and to consist of east and west cracks, having loosened the whole slope for nearly a mile northward of Chittenden, causing great landslides. The fault-line crosses the Pajaro River at the railway bridge at Chittenden. The movement is shown by the disturbance of the concrete bridge piers. (See plates 17A, 65B, and fig. 43.) Thence straight across the low hills and fields on the opposite side of the river a line of cracks extends, passing 0.5 mile west of Mr. Canfield's house, "just where the earth cracked 16 years ago." This crack crosses the Sargent-San Jose road a mile north of San Juan,



A. Reservoir in saddle south of Saratoga traversed by main fault, D.



B. Offset in rocks at Morrell's tract, above tunnel at Wright's station. This particular emplacement was not found in tunnel. G. A. W.

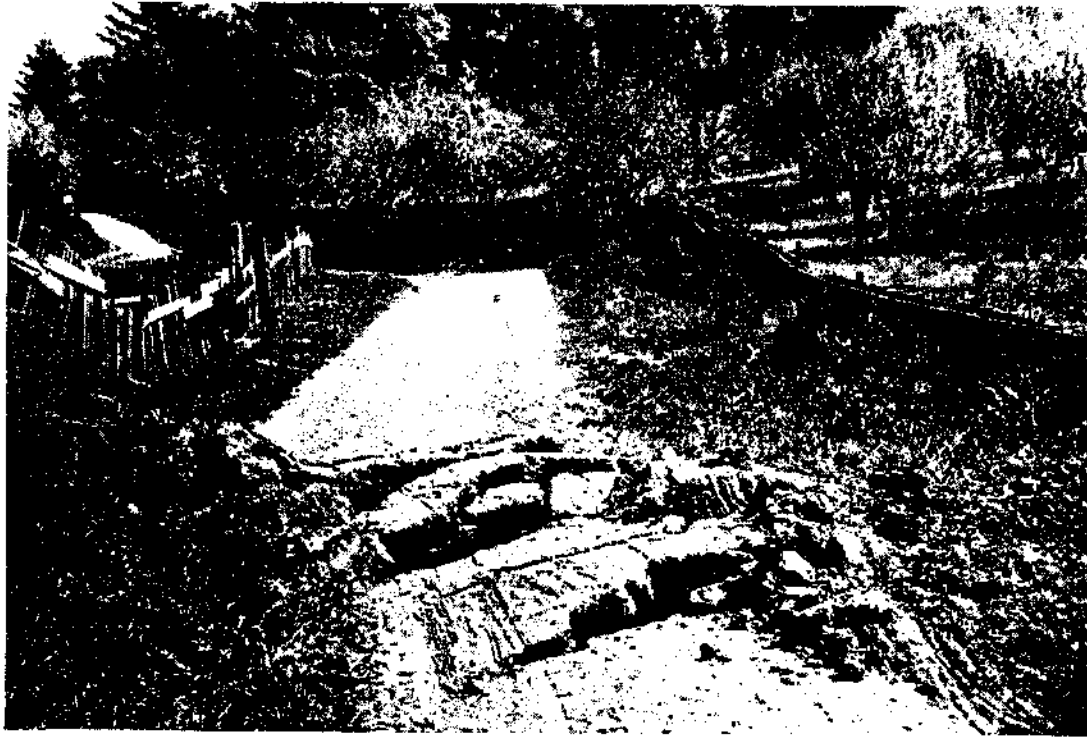

A. Offset in road near "Wright. Q. A. W.

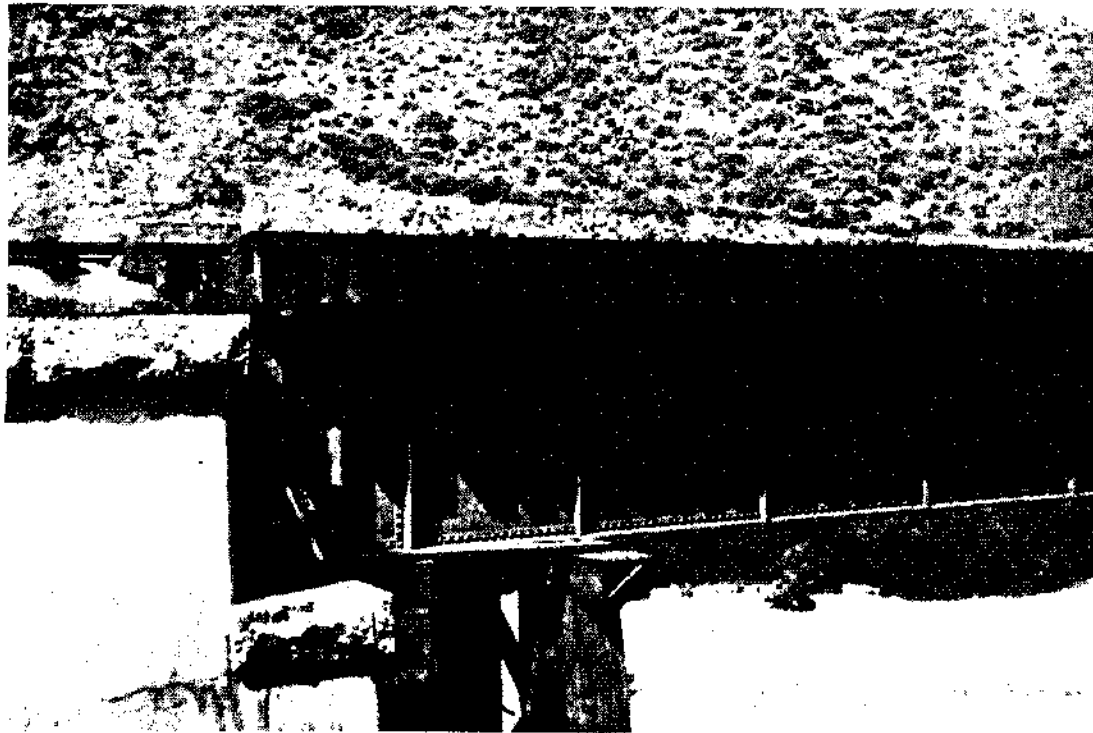

B. Steel bridge over Pajtro Eirer, near Oiiittenden, dragged from its abutment 3.5 fwt. Compare Fig. 43. A. O. L.

as a single fissure 3 inches wide, trending S. 53° E. In the lowland to the southeast there is little evidence of the fault, but crossing at right angles the county road running north and south about a mile east of San Juan, is a band of small cracks 15 feet wide, causing the road to sink 8 inches and making a marsh of the field beyond. This is believed to be the southernmost point of the recent opening of the fault. No trace of it could be found where it would have crossed roads beyond, nor were other cracks found or reported in this neighborhood. The disturbance affected the banks of the Pajaro River from Chitenden to Sargent, causing a cracking and sloughing of the banks into the stream but not a settling of the stream bed. The San Benito River was similarly shaken for about 3 miles up from its junction with the Pajaro. Cracks are also noticeable all along the Riverside road wherever it runs close to the river bank. The damage to the concrete abutments of the county bridge across the Pajaro River is due to this crowding in of the alluvial banks of the stream.

*The tunnel at Wright Station* (E. P. Carey). — Mr. Everett P. Carey reports that he made an examination of the tunnel at Wright Station soon after the earthquake, and again on February 17, 1907. The result of his observations is incorporated in the following memorandum:

The length of the tunnel is 6,200 feet. Its direction is S. 48° 24'.5 W. A fissure crossed the tunnel 400 feet from the northeast portal, along which there was a lateral displacement of 4.5 feet. The movement on the southwest side was northerly with reference to the northeast side. Nothing of this fissure can now be seen, as the tunnel along that part has been excavated, the walls timbered and entirely obscured from view. My description rests on my examination soon after the earthquake, before any work had been done. The strike of this fissure is N. 52° W., making an angle of 80° with the trend of the tunnel, and it dips at an angle of about 75° to the west. The walls of the fissure were well smoothed and slicken-sided, but I did not determine the direction of the strike. Specimens from this fissure indicate that the fault occurred in sandstone, and that much movement had already taken place along the same fault in apparently a variety of directions. Specimens secured at the time have changed from a damp, sticky, clay-like mass to a relatively dry, hard, and crumbled condition. Streaks of light-colored sandstone occurred in this dark attrition material.

The damage to the tunnel itself consisted in the caving in of overhead rock; the crushing in toward the center of the tunnel of the lateral upright timbers, and the heaving upward of the rails, due to the upward displacement of the underlying ties. In some instances these ties were broken in the middle. In general the top of the tunnel was carried north or northeast with reference to the bottom. This seems to be the prevailing condition in the exposed part of the tunnel not yet repaired.

I examined with particular care the walls of the tunnel at several points where the damage to the timbers appeared to be greatest, more especially between 1,400 feet and 2,200 feet in from the opening at Wright. At each place I found several fissure lines running somewhat irregularly, but in general parallel to the fissure already described 400 feet in from the entrance at Wright. These fissures all contained more or less attrition material. Three of them I had an opportunity to examine better than the others. In each case two distinct sets of striae were found, one set vertical and the other set horizontal. The horizontal set was clearly more recent than the vertical set, and to all appearances might have been formed the day before. The three slicken-sided faults mentioned were the only ones that look as if recent movement had occurred. The rocks in the tunnel look like sandstones and jaspers of Franciscan age. According to the evidence, so far as it went, the whole of the top of the mountain is fissured thruout in such a way that a large movement could be distributed among several fissures and thus account for a relatively slight motion along any one fissure. The measuring of any minor movements in the tunnel would be difficult because of the caving in of the rocks at such points. It would seem, too, that such movement could occur without materially altering the line of the tunnel at that point, so far as the timbering is concerned.

As far as learned no recognized fissures or faults have been crossed by the workmen thus far, except the one 400 feet from the northeast portal. Nothing corresponding to the fissure passing Morrell's house has yet been found in the tunnel.

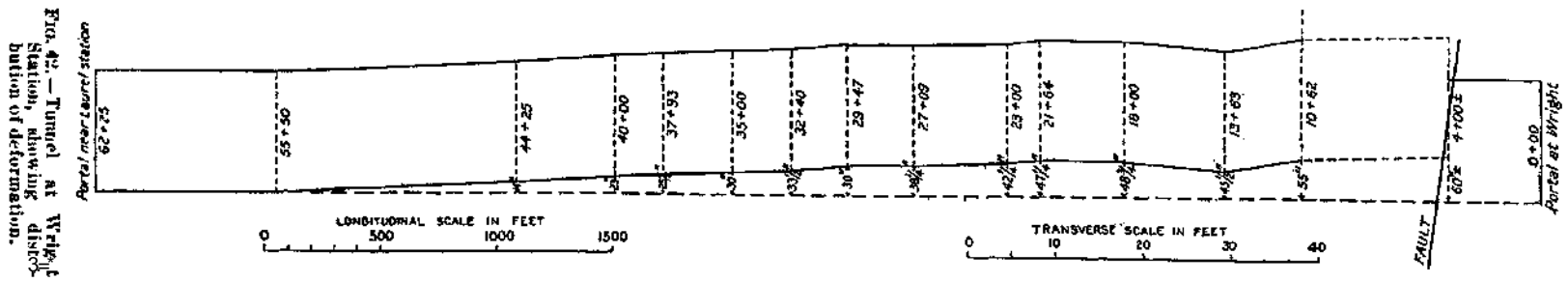

FIG. 42.—Tunnel at Wright Station, showing distribution of deformation.

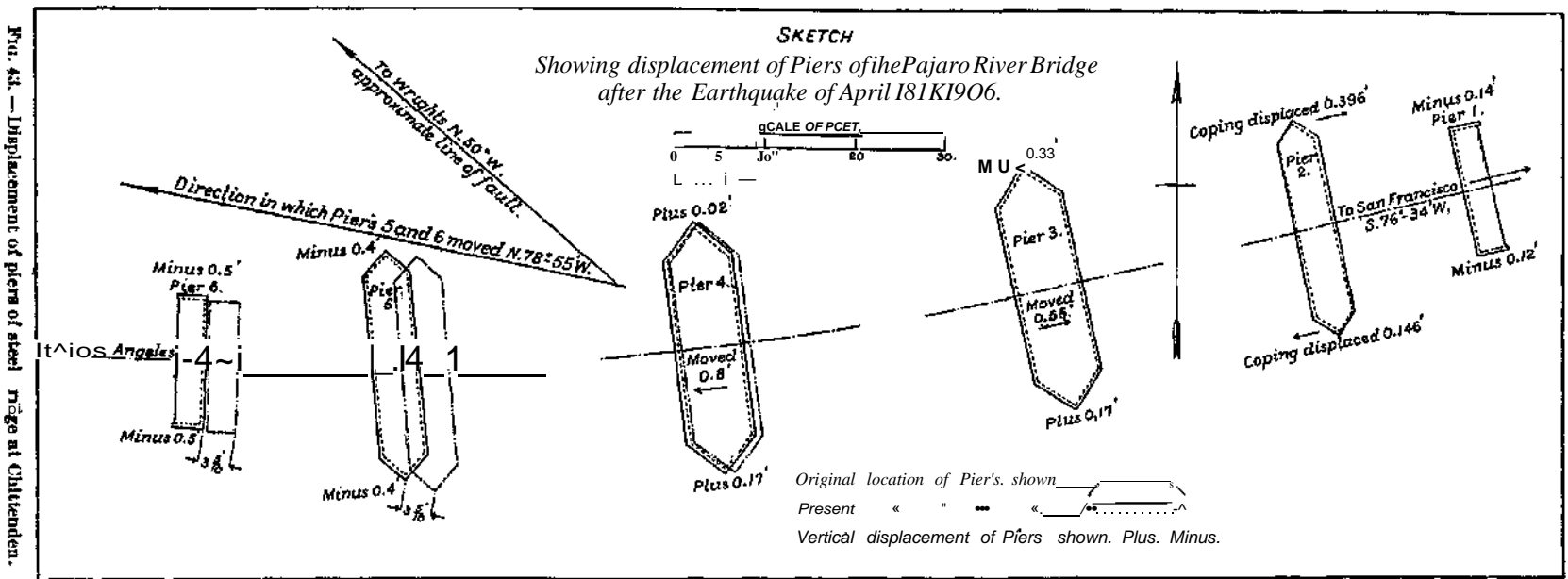

FIG. 43.—Displacement of piers of steel bridge at Chittenden.

*Engineers' measurements of displacement.* — The reconstruction of the tunnel at Wright Station necessitated an instrumental survey of the displacement in so far as it immediately affected the structure. The results of this survey have been placed at the disposal of the Commission by Mr. J. D. Matthews, assistant resident engineer in charge of the work. The plot of the survey is given in fig. 42. The plot shows that, while the tunnel is traversed by only one fault fracture, at a distance of about 400 feet from the northeast portal the deformation has been distributed over a distance of nearly a mile. This deformation of the tunnel, or its departure from a straight line, is measured from a line drawn from the northeast portal to a point on the same side of the tunnel 675 feet in from the southwest portal. It indicates a bending of the ground to the northwest in the direction of the relative displacement on the southwest side of the fault. That is to say, the bending is in the opposite direction to that which would be characteristic of the drag of a fault. A possible explanation of this phenomenon is that the ground pierced by the tunnel was in a state of excessive elastic stress, even at the time the tunnel was constructed; and that the relief effected by the rupture rendered resilience operative and so caused the ground to be flexed in the sense opposite to that of a drag. The nature of the deformation of the ground on the northeast side of the fault is not yet known. It may be here mentioned, in regard to the effect of the fault upon the steel bridge at Chittenden, that, in addition to the cracking and displacement of the supporting piers, as noted by Mr. Waring, the distance between the abutments was lengthened about 3.5 feet, according to measurements supplied to the Commission by Mr. J. H. Wallace, Assistant Chief Engineer, Southern Pacific Company, and illustrated in the accompanying diagram, fig. 43.

## GEODETIC MEASUREMENTS OF EARTH MOVEMENTS.<sup>1</sup>

BY JOHN F. HAYPORD AND A. L. BALDWIN.

### GENERAL STATEMENT.

The Coast and Geodetic Survey has done much triangulation in California to serve as a control or framework for its surveys along the coast and other surveys. The results of all the triangulation, south of the latitude of Monterey Bay, together with the primary triangulation to the northward, have already been published.<sup>2</sup> In 1906 the results of the triangulation in California, from the vicinity of Monterey Bay northward, were being prepared for publication. The reports from various sources in regard to the effects of the earthquake of April 18, 1906, indicated that there had been relative displacements of the earth's surface of from 2 meters (7 feet) to 6 meters (20 feet) at various points near the great fault accompanying the earthquake. These were relative displacements of points on opposite sides of the fault and had been reported along all parts of the fault for 185 miles, from the vicinity of Point Arena, in Mendocino County, to the vicinity of San Juan, in San Benito County.<sup>3</sup> The average relative displacement was said to be about 3 meters (10 feet). Displacements of that size would so change the relative positions of points which had been determined by triangulation and so change the lengths and directions of the lines joining them that the triangulation would no longer be of value as a means of control for accurate surveys. The value of the triangulation could be restored only by repeating a sufficient amount of it to determine definitely the extent and character of the absolute displacements. It was, therefore, decided to repair the old triangulation, damaged by the earthquake, by doing new triangulation.

If the displacements of a permanent character had occurred in a narrow belt only, close to the fault, but a few triangulation points would have been affected. The available evidence, however, indicated that the movements probably extended back from the fault for many miles on each side, and that the new triangulation necessary for repair purposes must, therefore, cover a wide belt.

The new triangulation to repair the damage was completed in July, 1907. In addition to serving this practical purpose, it has shown the character of the earth movements of 1906, which were found to extend back many miles on each side of the fault. These are very interesting results from a purely scientific point of view. Moreover, there came to light, during the study of the movements of 1906, entirely unexpected evidence of earlier earth movements, probably in 1868, which also affected a large area.

The purpose of this paper is to set forth fully the amount and nature of these two great displacements of large portions (at least 4,000 square miles) of the earth's crust and to indicate the degree of certainty in regard to these displacements warranted by the evidence.

### EXTENT OF NEW TRIANGULATION.

The new triangulation done during the interval July 12, 1906, to July 2, 1907, extends continuously northwestward from Mount Toro, in Monterey County, and Santa Ana Mountain, in San Benito County, to Ross Mountain, and the vicinity of Fort Ross, in Sonoma County. This new continuous triangulation, as indicated on map No. 24, extends over an area 270 kilometers (170 miles) long and 80 kilometers (50 miles) wide, at its widest part. It includes the station known as Mocho, about 11.1 miles northeast from Mount Hamilton

<sup>1</sup> Published by permission of the Superintendent of the Coast and Geodetic Survey.

<sup>2</sup> See Appendix 9 of the Report of the Coast and Geodetic Survey for 1904, *Triangulation in California*, Part I, by A. L. Baldwin, Computer.

<sup>3</sup> Preliminary Report, State Earthquake Investigation Commission, Berkeley, May 31, 1906.

and a station on Mount Diablo, both on the eastern side of the fault and 53 kilometers (33 miles) from it. It also includes the Farallon Light-house on the west side of the fault and 36 kilometers (22 miles) from it. There were, in all, 51 old triangulation stations which were recovered and their new positions accurately determined by the new triangulation. The stations had been marked upon the ground by stone monuments, by bolts in rock, etc., or by permanent structures such as the Farallon Light-house, Point Reyes Light-house, and the small dome of Lick Observatory, or were themselves permanent marks; as, for example, Montara Mountain peak (a sharp peak).

This continuous scheme consists of a chain of primary triangulation comprizing the eleven occupied stations, Mount Toro, Gavilan, Santa Cruz Azimuth Station, Loma Prieta, Sierra Morena, Mocho, Mount Tamalpais, Point Reyes Hill, Tomales Bay, Sonoma Mountain, and Ross Mountain; triangulation of the secondary grade of accuracy extending from the stations, Mount Tamalpais, Mount Diablo, Rocky Mound, and Red Hill, to the Pulgas Base near the southern end of San Francisco Bay, and triangulation of a tertiary grade of accuracy in three different localities; namely, in the vicinity of Colma, west of San Francisco Bay, along Tomales Bay, and in the vicinity of Fort Ross, Sonoma County.

The primary and secondary triangulation are shown on map No. 24, and the tertiary triangulation on map No. 25. On these two maps the straight blue lines indicate lines over which observations were taken in the new triangulation. The small red circles indicate stations marked upon the ground, of which the relative positions were fixed by the triangulation. Observations were taken in both directions over each blue line which is unbroken, thruout its length. Observations were taken in one direction, only, from the solid end toward the broken end, over each blue line which is broken at one end. A station from which no blue line is drawn unbroken was not occupied. The position of such a station was determined by intersections from the occupied stations.

In addition to this continuous triangulation, a detached piece of new triangulation of the secondary grade of accuracy, connecting old triangulation stations, was done in the vicinity of Point Arena. (See map No. 25.) This makes the total number of old triangulation stations which were recovered and redetermined 61.

In connection with the new triangulation, astronomic determinations of azimuth or true direction were made by observations on Polaris at the stations Mount Tamalpais, Mocho, and Mount Toro.

Four different observers, each with his own complete outfit and party, were engaged in the new work for an aggregate period of 35 months. The observers were all field officers of the Coast and Geodetic Survey, with previous experience in triangulation.

Mr. J. F. Pratt, Assistant, was in the field from August 4, 1906, to July 2, 1907, and made the observations at the five primary stations, Ross Mountain, Sonoma Mountain, Tomales Bay, Point Reyes Hill, and Mount Tamalpais.

Mr. W. B. Fairfield, Assistant, was in the field from August 11, 1906, to May 29, 1907. He did nearly all of the Tomales Bay triangulation, made the observations at the primary stations, Mocho and Sierra Morena, and did a part of the secondary triangulation in the vicinity of Pulgas Base.

Mr. C. H. Sinclair, Assistant, was in the field from July 14, 1906, to April 10, 1907. He made the observations at the primary stations, Santa Cruz Azimuth Station, Loma Prieta, Gavilan, and Mount Toro, and also did a part of the secondary triangulation in the vicinity of Pulgas Base.

Mr. Edwin Smith, Assistant, was in the field from July 12 to July 24, 1906, engaged in making the reconnaissance and other preparations for triangulation along Tomales Bay. He was then called away on other duty and Assistant Fairfield completed the Tomales Bay triangulation. Between September 26, 1906, and February 26, 1907, Mr. Smith did



the secondary triangulation in the vicinity of Point Arena and the tertiary triangulation in the vicinity of Fort Ross and in the vicinity of Colma.

These observers remained at their work continuously in spite of many delays and discomforts due to fog, rain, snow, gales, and roads which were at times nearly or quite impassable. To them must be given the credit for overcoming the difficulties and securing the observations of the necessary high grade of accuracy.

#### THE OLD TRIANGULATION.

The old triangulation fixing the positions of the points before the earthquake of April 18, 1906, was done in many years, extending from 1851 to 1899, as a part of the regular work of the Coast and Geodetic Survey and without reference to the possible future use of this triangulation as a means of determining the movements of permanent character due to earthquakes. During the earlier years certain parts of this old triangulation had existed as detached triangulation not connected with other parts. Before 1906, however, all parts of the old triangulation had been connected with each other by triangulation to form one continuous scheme. It was also connected with other triangulation extending to many parts of the United States, including many of the interior states, as well as the Atlantic and Gulf Coasts.

In connection with studies of the evidence as to the earth movements set forth in this paper, it is important to note briefly the dates of the old triangulation which serves, in connection with the new triangulation of 1906-1907, to determine changes in positions of marked points on the earth's surface.

During the years 1854-1860 primary triangulation was carried from the stations, Rocky Mound, Red Hill, and Mount Tamalpais, northward to Ross Mountain, thru a primary scheme practically identical with that shown on map No. 24, except that the station Bodega was occupied in this earlier triangulation, tho not in 1906-1907.

Tertiary triangulation, following substantially the scheme shown on map No. 25, was also done in 1856 to 1860, along Tomales Bay, starting with the line Tomales Bay-Bodega, of the primary triangulation referred to in the preceding paragraph. In connection with this work, the station Chaparral of the Fort Ross triangulation, shown on map No. 25, was also determined.

Primary triangulation was done during the years 1851 to 1854, connecting the group of stations, Mount Diablo, Rocky Mound, Red Hill, with the Pulgas Base, the scheme being somewhat different from that shown on map No. 24, but equally direct and strong.

During the years 1854-1855, 1864, 1866, primary triangulation was done connecting the stations in the vicinity of Rocky Mound, referred to in the preceding paragraph, with stations Gavilan, Santa Cruz, and Point Pinos Light-house around Monterey Bay. This triangulation, for the greater part of its length, consists of a single chain of triangles, affording, therefore, comparatively few checks upon the results.

This practically completes the statement of triangulation done before 1868 which is concerned in the present investigation. The extent of the triangulation done between 1868 and 1906 is stated separately in the following paragraphs.

Northward of the line Mount Diablo-Mount Tamalpais, but one station of the primary scheme, shown on map No. 24, was determined by primary triangulation in the interval 1868-1906; namely, Ross Mountain. It was determined directly from the stations Mount Tamalpais, Mount Diablo, and Mount Helena of the transcontinental triangulation.<sup>1</sup>

During the years 1876-1887, primary triangulation was extended southward (by substantially the same scheme as that shown on map No. 24, except that station Gavilan was omitted) from the line Mount Diablo-Mount Tamalpais to the line Mount Toro-

<sup>1</sup> See The Transcontinental Triangulation, Special Publication No. 4, pp. 597-608.

Santa Ana. Some pointings were also taken on Gavilan, Point Pinos Light-house, and other stations in this vicinity, but not from a sufficient number of stations to furnish checked determinations independent of earlier determinations made before 1868.

Secondary triangulation near Point Arena, forming the western extremity of the transcontinental triangulation, was done in the interval 1870-1892, the scheme being substantially the same as that shown on map No. 25, except that all stations were occupied. The triangulation fixing the initial stations, Fisher and Cold Spring, has been published.<sup>1</sup>

Tertiary triangulation in the vicinity of Fort Ross was done in 1875-1876, following a scheme similar to that shown on map No. 25, and starting from the line Bodega Head-Ross Mountain, as determined before 1868.

Tertiary triangulation was done during various years from 1851-1899, extending from the vicinity of the Pulgas Base northward, spanning San Francisco Bay, to the Golden Gate, and thence southward to the vicinity of Colma, including stations shown on sketch No. 4 on map No. 25. The greater portion of this triangulation was done before 1868, but it is impracticable to separate the computations into two parts dealing with triangulation before and triangulation after 1868, respectively.

#### PERMANENT DISPLACEMENTS PRODUCED BY THE EARTHQUAKES OF 1868 AND 1906.

The following tables, Nos. 1, 2, and 3, show the permanent displacements of various points as caused by the earthquakes of 1868 and 1906. These permanent displacements were determined by comparisons of the positions of identical points upon the earth's surface as determined by triangulation done before and after the earthquakes in question.

While for the sake of brevity in statement these movements are referred to the earthquakes of 1868 and 1906, the evidence furnished by the triangulation simply indicates the fact that the displacements in question took place sometime during the two blank intervals within which there was no triangulation done fixing the points in question; namely, the interval 1866-1874, including the 1868 earthquake, and the interval 1892 to July, 1906, including the 1906 earthquake. Neither does the triangulation furnish any evidence indicating whether the displacements took place gradually, extending over many months and possibly years, or whether they took place suddenly. The evidence connecting the displacements of 1906 with the particular earthquake and indicating that they were sudden comes from other sources and will be commented upon later in this report.

The permanent displacements indicated in tables 1, 2, and 3, must be carefully distinguished from the vibrations of a more or less elastic character which take place during earthquakes. These vibrations die down in a few seconds, minutes, or hours. While they are in progress, a given point on the earth's surface is in continuous motion along a more or less complicated path which turns upon itself and leaves the point, at the end of the vibration, near the initial position. The displacements indicated in tables 1, 2, and 3, on the other hand, remain for years, possibly for centuries. They are of a permanent character. The displaced point remains in the new position until another displacement occurs in some later earthquake, or possibly by slow relief of strain accompanied by a creeping motion which causes a new permanent displacement. In tables 1, 2, and 3, the first column gives the name of the station by which it may also be identified on map 24 or on map 25, or both. The second column gives its latitude at the time indicated in the heading. The third column gives the seconds, only, of the new latitude at the later time indicated in the heading. The fourth and fifth columns have the same significance with reference to the longitude that the second and third have with reference to the latitude of each point. The sixth column gives the north and south component of the displace-

<sup>1</sup> See The Transcontinental Triangulation, Special Publication No. 4, pp. 597-010.

Table 1.—Displacements of 1906.

STATION	LATITUDE AFTER 1868		LATITUDE in Oct-07	LONGITUDE AFTER 1868		LONGITUDE 1906-07	SOUTHWARD COMPONENT OF DISPLACEMENT	EASTWARD COMPONENT OF DISPLACEMENT	DIRECTION OF DISPLACEMENT	AMOUNT OF DISPLACEMENT		RELATION TO FAULT		DEGREE OF CERTAINTY	
	°	'		°	'					Meters	Feet	Km.	Miles		Dir.
GROUP 1.															
Rocky Mound . . . . .	37°	52'	57.253"	57.262"	122°	14'	30.507"	30.515"	-0.28	-0.20	145°	0.34	1.1	32 20 E	Doubtful.
Red Hill . . . . .	37	33	04.730	04.738	122	05	40.982	40.975	-0.25	+ 0.17	215	0.30	1.0	19 12 E	Do.
Sierra Morena . . . . .	37	24	38.266	38.305	122	18	28.006	28.054	- 1.20	-1.18	136	1.68	5.5	4.3 2.7 W	Certain.
Mount Tamalpais . . . . .	37	55	27.507	27.492	122	35	45.242	45.228	+ 0.46	+ 0.34	324	0.58	1.9	6.4 4.0 E	Do.
Farallon Lighthouse . . . . .	37	41	58.250	58.277	123	00	03.605	03.669	-0.83	-1.57	118	1.78	5.8	37 23 W	Do.
Pt. Revest Light-house . . . . .	37	59	45.458	45.572	123	01	20.577	20.618	-0.43	- 1.00	113	1.09	3.6	19 12 W	Doubtful.
Point Reyes Hill . . . . .	38	04	48	.....	122	52	01	.....	(- 2.96)	(- 2.25)	(143)	(3.72)	(12.2)	2.7 1.7 W	Inferred, certain.
Tornales Bay . . . . .	38	10	55	.....	122	56	47	.....	(- 3.06)	(- 2.41)	(142)	(3.89)	(12.8)	2.1 1.3 W	Do.
Bodega . . . . .	38	18	24	.....	123	00	04	.....	(+ 1.16)	(+ 0.89)	(323)	(1.47)	(4.8)	2.0 1.2 E	Inferred, reasonably certain.
Ross Mountain . . . . .	38	30	20.583	20.572	123	07	09.221	09.204	+ 0.34	+ 0.41	309	0.53	1.8	7.0 4.3 E	Doubtful.
GROUP 3.															
Black Ridge 2 . . . . .	37	44	54.214	54.207	122	27	59.502	59.505	+ 0.22	-0.07	19	0.23	0.7	7.0 4.3 E	Doubtful. <sup>1</sup>
Bonita Pt. Light-house . . . . .	37	48	57.447	57.363	122	31	43.569	43.554	+ 2.59	+ 0.37	352	2.62	8.6	6.0 3.7 E	Do.
San Bruno Mountain . . . . .	37	41	16.130	16.129	122	26	05.344	05.334	+ 0.03	+ 0.24	277	0.25	0.8	5.1 3.2 E	Do.
Black Bluff . . . . .	37	43	10.158	10.149	122	30	12.684	12.672	+ 0.28	+ 0.29	313	0.40	1.3	2.5 1.6 E	Do.
Road . . . . .	37	37	57.595	57.665	122	28	28.512	28.559	-2.16	-1.15	152	2.45	8.0	1.5 0.9 W	Do.
Flat . . . . .	37	36	51.991	52.060	122	27	35.197	35.236	-2.13	-0.96	156	2.33	7.7	1.5 0.9 W	Do.
False Cattle Hill 2 . . . . .	37	36	50.401	50.460	122	29	40.926	40.967	- 1.82	- 1.01	151	2.08	6.8	4.1 2.5 W	Do.
Montara Mountain Pk. . . . .	37	33	42.506	42.549	122	28	36.940	36.904	- 1.33	+ 0.88	214	1.59	5.2	6.1 3.8 W	Do.
San Pedro Rock . . . . .	37	35	44.158	44.239	122	31	22.422	22.441	-2.50	-0.47	169	2.54	8.3	7.4 4.6 W	Do.
GROUP 4.															
Bodega Head . . . . .	38	18	29	.....	123	03	45	.....	(- 3.56)	(- 0.52)	(172)	(3.60)	(11.8)	2.2 1.4 W	Inferred, certain.
Tomales Point . . . . .	38	12	46	.....	122	58	14	.....	(- 2.81)	(- 2.24)	(141)	(3.59)	(11.8)	2.0 1.2 W	Do.
Foster . . . . .	38	08	13	.....	122	54	23	.....	(- 3.61)	(- 2.83)	(142)	(4.59)	(15.1)	1.9 1.2 W	Do.
Smith . . . . .	38	14	52	.....	122	56	09	.....	(+ 1.46)	(+ 0.80)	(331)	(1.66)	(5.4)	2.6 1.6 E	Do.
Mershon . . . . .	38	10	55	.....	122	54	06	.....	(+ 1.90)	(+ 0.42)	(348)	(1.95)	(6.4)	1.1 0.7 E	Do.
Hans . . . . .	38	07	58	.....	122	52	02	.....	(+ 1.94)	(- 0.23)	(7)	(1.95)	(6.4)	0.5 0.3 E	Inferred, doubtful.
Hammond . . . . .	38	04	45	.....	122	48	35	.....	(+ 1.79)	(-1.42)	(38)	(2.28)	(7.5)	1.2 0.7 E	Do.

U.S. GEOLOGICAL SURVEY  
 GEOLOGICAL DIVISION  
 WASHINGTON, D.C.

Station	Group	38	25	53.725	53.704	0	0	0	04.05	+ 0.65	+ 1.09	801	1.27	4.2	C0	E	Reasonably cert.
Peaked Hill	Group 5.																
Lancaster		38	25	16.134	16.086	18	44.2	0	44.28	+ 1.48	+ 0.97	317	1.77	5.8	13.5	E	Assumed.
Chaparral		38	25	33.964	33.927	10	56.2	0	56.28	+ 1.14	+ 0.70	318	1.84	4.4	11.2	E	Unmoved.
Dixon		38	25	30.735	30.703	11	54.4	0	54.48	+ 0.99	+ 0.94	319	1.37	4.5	3.9	E	Do.
Henry Hill		38	25	47.724	47.688	14	27.5	0	27.58	+ 1.11	+ 0.84	320	1.46	4.8	3.8	E	Do.
Salt Point		38	25	00.302	00.360	19	57.7	0	57.78	- 1.48	- 1.36	321	2.01	6.6	0.2	W	Do.
Horseshoe Point		38	25	27.969	28.004	22	09.4	0	09.48	- 1.08	- 1.02	322	1.48	4.9	0.9	W	Do.
Stockhoff		38	25	57.016	57.013	18	11.8	0	11.88	- 1.45	- 1.04	323	1.78	5.9	1.6	W	Do.
Timber Cove		38	25	59.557	59.615	16	35.5	0	35.58	- 1.70	- 1.31	324	2.22	7.3	1.2	W	Do.
Fort Ross		38	25	46.084	46.152	15	12.6	0	12.68	- 2.19	- 1.86	325	2.50	8.2	1.2	W	Do.
Pinnacle Rock		38	25	02.982	03.056	14	02.9	0	02.98	- 2.28	- 0.94	326	2.47	8.1	1.0	W	Do.
Kunke		38	25	34.972	35.029	18	07.3	0	07.38	- 1.76	- 1.52	327	2.33	7.6	0.2	W	Do.
Cold Spring	Group 6.	39	01	21.8	21.8	31	20.468	0	20.468						13.5	E	Assumed.
Fisher		39	01	59.721	59.721	123	35	0	35.08	+ 0.68	+ 0.41	328	0.79	2.6	11.2	E	Unmoved.
Dunn		39	01	39.986	39.986	123	38	0	38.08	+ 0.71	+ 0.43	329	0.83	2.7	3.9	E	Do.
Clark		39	01	37.744	37.744	123	37	0	37.08	+ 1.23	+ 0.89	330	1.51	5.0	3.8	E	Do.
Spur		39	01	16.549	16.549	123	41	0	41.08	+ 1.42	+ 0.53	331	3.27	10.7	0.2	W	Do.
Lane		39	01	34.636	34.636	123	41	0	41.08	- 3.14	- 0.89	332	2.67	8.8	1.5	W	Do.
Sh		39	01	58.425	58.425	123	40	0	40.08	- 2.56	- 0.77	333	2.46	8.0	5.7	W	Do.
Pt		39	01	45.079	45.16	123	41	0	41.08	- 2.31	- 0.80	334	2.57	8.4	6.4	W	Do.
Light-house		39	01	18.722	18.722	123	44	0	44.08	- 2.44	- 0.82	335	2.78	9.1	6.7	W	Do.
High		39	01	03.866	03.866	123	41	0	41.08	- 2.59	- 1.01	336	2.54	8.3	6.8	W	Do.
ema		39	01	18.927	19.045	123	43	0	43.08	- 2.40	- 0.82	337	2.54	8.3	7.6	W	Do.
Lick	Group 7.	37	20	31.511	31.511	121	38	0	38.08	+ 0.12	+ 0.12	338	0.12	0.1	88	E	Unmoved.
Let		37	20	40.912	40.912	121	50	0	50.08	+ 0.82	+ 0.82	339	0.97	0.0	88	E	Do.
Santa		36	37	08.821	08.821	122	01	0	01.08	+ 0.37	+ 0.37	340	0.62	0.0	108	W	Do.
Al		36	31	34.712	34.712	121	36	0	36.08	+ 0.30	+ 0.30	341	0.95	0.0	88	W	Do.
Santa Cruz Az. Sta.		36	58	42	42	122	03	0	03.08	- 1.78	- 1.78	342	(1.88)	0.0	108	W	Inferred, very doubtful.
Gavilto		38	45	21	21	121	31	0	31.08	+ 1.48	+ 1.48	343	(2.19)	(7.2)	6.4	W	Do.
Pt. Pinos Light-house		36	58	01	01	121	55	0	55.08	+ 2.86	+ 2.86	344	(3.09)	(10.1)	39	W	Do.
Point		36	37	59	59	121	55	0	55.08	+ 2.31	+ 2.31	345	(2.32)	(7.6)	39	W	Do.

\* Though the absolute displacements are all doubtful, only two of the relative displacements are doubtful, namely, Bonita Point Light-house and Montara Mountain Peak.

Table 2.—Permanent Displacements in 1868.

STATION-	LATITUDE BEFORE 1868		LONGITUDE BEFORE 1868		LONGITUDE AFTER 1868	SOUTHWARD COMPONENT OF DISPLACEMENT	EASTWARD COMPONENT OF DISPLACEMENT	DIRECTION OF DISPLACEMENT	AMOUNT OF DISPLACEMENT		DEGREE OF CERTAINTY <sup>1</sup>
	Latitude	Longitude	Latitude	Longitude					Meters	Feet	
<b>GROUP 1.</b>											
Rocky Mound . . . . .	37°	52' 57.237"	57.253"	122° 14' 30.510"	30.507*	-0.49	+ 0.07	188°	0.50	1.6	Doubtful.
Red Hill . . . . .	37	33 04.717	04.730	122 05 41.003	40.982	-0.40	+ 0.52	232	0.65	2.1	Do.
Mount Tamalpais . . . . .	37	55 27.455	27.507	122 35 45.228	45.242	- 1.60	-0.34	168	1.64	5.4	Certain.
Farallon Light-house . . . . .	37	41 58.210	58.250	123 00 03.579	03.605	- 1.23	-0.64	153	1.39	4.6	Do.
Point Reyes Hill . . . . .	38	04 48.325	.....	122 52 00.801	.....	(- 1.51)	(- 0.31)	(168)	(1.54)	(5.0)	Inferred, certain.
Tomales Bay . . . . .	38	10 55.456	.....	122 56 46.733	.....	(- 1.56)	(- 0.22)	(172)	(1.57)	(5.2)	Do.
Bodega . . . . .	38	18 23.680	.....	123 00 03.726	.....	(- 1.62)	(- 0.11)	(176)	(1.62)	(5.3)	Inferred, reasonably certain.
Ross Mountain . . . . .	38	30 20.528	20.583	123 07 09.223	09.221	- 1.70	+ 0.05	182	1.70	5.6	Reasonably certain.
<b>GROUP 4.</b>											
Bodega Head . . . . .	38	18 29.249	.....	123 03 45.417	.....	(- 1.62)	(-0.11)	(176)	(1.62)	(5.3)	Inferred, certain;
Tomales Point . . . . .	38	12 45.732	.....	122 58 14.449	.....	(- 1.57)	(- 0.19)	(173)	(1.58)	(5.2)	Do.
Foster . . . . .	38	08 13.410	.....	122 54 23.271	.....	(- 1.54)	(- 0.26)	(170)	(1.56)	(5.1)	Do.
Smith . . . . .	38	14 51.518	.....	122 56 08.865	.....	(- 1.58)	(-0.17)	(174)	(1.59)	(5.2)	Do.
Mershon . . . . .	38	10 55.295	.....	122 54 06.016	.....	(- 1.56)	(- 0.22)	(172)	(1.57)	(5.2)	Do.
Hans . . . . .	38	07 58.492	.....	122 52 02.072	.....	(- 1.54)	(- 0.28)	(170)	(1.57)	(5.2)	Inferred, doubtful.
Hammond . . . . .	38	04 45.046	.....	122 48 34.993	.....	(- 1.51)	(- 0.31)	(168)	(1.54)	(5.1)	Do.
<b>GROUP 5.</b>											
Chaparral . . . . .	38	29 33.905	33.964	123 10 56.207	56.216	- 1.82	-0.22	173	1.83	6.0	Reasonably certain.
<b>GROUP 7.</b>											
Loma Prieta . . . . .	37	06 40.971	40.912	121 50 36.521	36.423	+ 1.82	+2.42	307	3.03	9.9	Certain.

Table 3.—Combined Displacements of 1868 and 1906.

STATION	LATITUDE BEFORE 1868	LATITUDE 1906-07	LONGITUDE BEFORE 1868	LONGITUDE 1906-07	SOUTHWARD COMPONENT OF DISPLACEMENT	EASTWARD COMPONENT OF DISPLACEMENT	DIRECTION OF DISPLACEMENT	AMOUNT OF DISPLACEMENT	RELATION to FAULT	DEGREE OF CERTAINTY
GROUP 1.										
Rooky Mound . . . . .	37° 52' 57.237"	57.262"	122° 14' 30.510"	30.515"	-0.77	- 0.12	171°	Meters Feet	Km. Miles Dir.	Doubtful.
Red Hill . . . . .	37 33 04.717	04.738	122 05 41.003	40.975	-0.65	+ 0.69	227	0.78 2.6	32 20 E	Certain.
Mount TamalpaLs . . . . .	37 55 27.455	27.492	122 35 45.228	45.228	- 1.14	0.00	180	0.94 3.1	19 12 F	Do.
Farallon Light-house . . . . .	37 41 58.210	58.277	123 00 03.579	03.669	-2.07	-2.20	133	1.14 3.7	6.4 4.0 E	Do.
Point Reyes Hill . . . . .	38 04 48.325	48.470	122 52 00.801	00.906	-4.47	-2.56	150	3.02 9.9	37 23 W	Do.
Tomales Bay . . . . .	38 10 55.456	55.606	122 56 46.733	46.841	-4.62	-2.63	150	5.15 16.9	2.7 1.7 W	Do.
Bodega . . . . .	38 18 23.680	23.695	123 00 03.726	03.694	-0.46	+ 0.78	239	5.32 17.5	2.1 1.3 W	Do.
Ross Mountain . . . . .	38 30 20.528	20.572	123 07 09.223	09.204	- 1.36	+ 0.46	199	0.90 3.0	2.0 1.2 E	Reasonably certain.
Sonoma Mountain . . . . .	38 19 24.539	24.579	122 34 27.894	27.891	- 1.23	+ 0.07	183	1.43 4.7	7.0 4.3 E	Do.
GROUP 2.										
Pulgas E. Base . . . . .	37 28 36.265	36.258	122 08 08.143	08.129	4-0.22	+ 0.34	302	1.24 4.0	34 21 E	Certain.
Guano Island . . . . .	37 34 23.655	23.649	122 15 43.475	43.479	+ 0.18	-0.10	28			Doubtful.
Pulgas W. Base . . . . .	37 28 48.787	48.764	122 15 15.681	15.673	+ 0.71	+ 0.20	344	0.41 1.3	12 7 E	Do.
GROUP 4.										
Bodega Head . . . . .	38 18 29.249	29.417	123 03 45.417	45.443	- 5.18	-0.63	173	0.21 0.7	10 6 E	Reasonably certain.
Tomales Point . . . . .	38 12 45.732	45.874	122 58 14.449	14.549	-4.38	-2.43	151	0.74 2.4	3.5 2.2 E	Certain.
Foster . . . . .	38 08 13.410	13.577	122 54 23.271	23.398	-5.15	-3.09	149	5.22 17.1	2.2 1.4 W	Do.
Smith . . . . .	38 14 51.518	51.522	122 54 08.865	08.839	-0.12	+ 0.63	259	5.01 16.4	2.0 1.2 W	Do.
Mershon . . . . .	38 10 55.295	55.284	122 54 06.016	06.008	+ 0.34	+ 0.20	330	6.01 19.7	1.9 1.2 W	Do.
Hans . . . . .	38 07 58.492	58.479	122 52 02.072	02.093	+ 0.40	- 0.51	52	0.64 2.1	2.6 1.6 E	Do.
Hammond . . . . .	38 04 45.046	45.037	122 48 34.993	35.064	+ 0.28	- 1.73	81	0.39 1.3	1.1 0.7 E	Do.
GROUP 5.										
Chaparral . . . . .	38 29 33.905	33.927	123 10 56.207	56.187	-0.68	+ 0.48	216	0.65 2.1	0.5 0.3 E	Doubtful.
GROUP 7.										
Black Mountain . . . . .	37 19 09.810	09.761	122 08 49.462	49.402	+ 1.51	+ 1.48	316	1.75 5.7	1.2 0.7 E	Do.
Lorna Prieta . . . . .	37 06 40.971	40.895	121 50 36.521	36.390	+ 2.34	+ 3.23	306	2.11 6.9	14 0.9 E	Certain.
Santa Cruz Az. Sta. . . . .	36 58 42.106	42.027	122 03 18.728	18.702	+ 2.44	+ 0.64	345	3.99 13.1	4.8 3.0 E	Do.
(Javilan . . . . .	36 45 21.068	20.961	121 31 11.504	11.341	+ 3.30	+ 4.04	309	2.52 8.3	19 12 W	Do.
Pt. Pinos Light-house . . . . .	36 38 01.551	01.399	121 55 58.939	58.795	+ 4.68	+ 3.58	323	5.22 17.1	6.4 4.0 W	Do.
Point Pinos Lat. Sta.. . . . .	36 37 59.413	59.279	121 55 31.685	31.578	+ 4.13	+ 2.66	327	5.89 19.3	39 24 W	Do.
								4.91 16il	39 24 W	Do.

THE EARTH MOVEMENT ON THE F OF APRIL 18, 1906. 121

ment along a meridian. A plus sign in this column means that the point moved toward the south. The seventh column shows the east and west component of the motion. A plus sign in this column means that the point moved toward the east. The sixth and seventh columns were computed by converting the changes in latitude and longitude, respectively, into meters.

By combining the values given in columns 6 and 7, the direction and amount of the displacement were obtained as shown in columns 8, 9, and 10. In column 8 the direction of displacement is given, reckoned as geodetic azimuths are usually reckoned, clockwise around the whole circumference from south as zero. In this reckoning, west is  $90^\circ$ , north,  $180^\circ$ , and east,  $270^\circ$ . Column 9 gives the amount of displacement in meters and column 10 gives it in feet. Column 11 shows the approximate distance of the point from the fault of 1906, measured approximately at right angles to the fault. In this column E indicates that the point is to the east of the fault and W that it is to the west.

For example: The fifth line of table 1 indicates that during the earthquake of 1906 the Farallon Light-house moved 0.83 meter north and 1.57 meters west, or, in other words, moved 1.78 meters (5.8 feet) in azimuth  $118^\circ$ , or  $62^\circ$  west of north, and that it is 37 kilometers (23 miles) from the fault of 1906 and to the west of it.

In the heading, the expression "Before 1868" refers to years within the interval 1851-1866. The expression "After 1868" refers to years within the interval 1874-1891, and "1906-1907" refers to dates within the interval July, 1906-July, 1907.

The latitudes and longitudes given in tables are all computed upon the U. S. Standard Datum and differ somewhat from those now in use on the charts and maps of this region. They are, however, the latitudes and longitudes to which all charts and maps should ultimately conform.

Table 1 shows the displacements which occurred on April 18, 1906; table 2 shows the displacements which occurred in 1868, and table 3 shows the total, or combined displacements in both 1868 and 1906.

For some cases, as, for example, Point Reyes Hill, the separate displacements were not directly determined by the triangulation but only the combined displacements. In such cases, if probable values could be derived for the separate displacements, indirectly, by inference from surrounding points, they were so derived and placed in the table. In each case, such inferred displacements are clearly distinguished in the table from others which were determined directly by measurement, by leaving the third and fifth columns blank and by having the values in the sixth to tenth columns enclosed in parentheses.

All of the displacements given in tables 1-3 are computed upon the assumption that the two stations, Mount Diablo and Mocho, remained unmoved during the earthquake of April 18, 1906. The reasons why this assumption is believed to be true will be set forth fully in a later part of this report.

In the tables the points are separated into seven groups for convenience of discussion. Each group of points is fixed by a portion of the triangulation which may conveniently be considered as a unit in discussing the magnitude of the possible errors of the triangulation. The discussion of the observed displacements and the degree of certainty in regard to them is given after the tables and deals with each group in succession.

The apparent displacements, as shown in the above tables, are of course in part due to the unavoidable errors in the triangulation and in part are doubtless actual displacements of the points. The triangulation furnishes within itself the means of estimating its accuracy. If the observations were absolutely exact, the sum of the observed angles of each triangle would be exactly  $180^\circ$  plus the spherical excess of that triangle, and moreover the computation of the length of the triangle sides would show no discrepancies, starting from a given line and ending on a selected line, but proceeding thru the various alternative sets of triangles which it is possible to select connecting said lines. In any

actual case, neither of these ideal conditions is found. Each triangle has a closing error, and the lengths computed along different paths thru the triangulation show discrepancies. These closing errors and discrepancies are a measure of the accuracy of the triangulation.

The triangulation, both old and new, was adjusted by the method of least squares. This method of computation, as applied to triangulation, takes into account simultaneously all the observed facts in connection with a group of triangulation stations and also all the known theoretical conditions connecting the observed facts; such, for example, as those mentioned in the preceding paragraph, in regard to closures of triangles and discrepancies in length. It is the most perfect method of computation known. The results of the computation are a set of lengths and azimuths (true directions) of lines joining the triangulation stations and of latitudes and longitudes defining the relative positions of the stations which are perfectly consistent; that is, contain no contradictions one with another and are the most probable values which can be derived from the observations. In such a computation, the measures of the accuracy of the computed results appear in the form of corrections to observed directions from station to station, which it is necessary to apply in order to obtain the most probable results given by the computation. The greater the accuracy of the observations the smaller are the corrections to directions.

In the problem in hand, in which, at least for some points, the observed apparent displacement is of about the same magnitude as the possible error in the apparent displacement due to accumulated errors of observation, it is necessary to make a careful estimate of the errors of observation and of the uncertainties of the computed displacements. This has been done and the estimates are given in general terms in the following text and are indicated in the last column of the tables. These estimates will help the reader to avoid drawing conclusions in detail not warranted by the facts.

*Group 1. Northern part of primary triangulation.*—In this group, as shown by tables 1-3 (see also map 24), there are 11 points of which the positions were redetermined after the earthquake of April 18, 1906. Of these, 9 had been determined before 1868 and 7 between 1868 and 1906.

There is about 1 chance in 3 that each of the two apparent displacements of Rocky Mound, 0.50 meter (1.6 feet), in 1868 (table 2), and 0.34 meter (1.1 feet), in 1906 (table 1), is simply the result of errors of observation. Similarly there is about 1 chance in 3 that the apparent displacement of Red Hill in 1868, 0.65 meter (2.1 feet), is the result of errors of observation. The chances are about even for and against the apparent displacement of Red Hill in 1906, 0.30 meter (1.0 foot), being simply the result of errors of observation. The effect of errors of observation upon the apparent displacements are larger at these two points than they otherwise would be on account of the difficulty in this vicinity of separating the triangulation into two complete schemes, one before 1868 and one after that date, each strong and complete.

According to the evidence furnished by the triangulation, the apparent displacement of Ross Mountain in 1906, 0.53 meter (1.8 feet) in azimuth  $309^\circ$  ( $51^\circ$  E. of S.), is probably the result of errors of observation. This apparent displacement as computed depends on the accumulated errors of the two triangulations from Mount Diablo to Ross Mountain, a distance of 130 kilometers (81 miles). The apparent displacement of 0.53 meter almost directly toward Mount Diablo corresponds to a shortening on the line Ross Mountain-Mount Diablo by 1 part in 250,000, too small a change to be detected with certainty by the triangulation.

On the other hand, there is about 1 chance in 15 that the apparent displacement of Ross Mountain in 1868, 1.70 meters (5.6 feet), is due to errors of observation. It is reasonably certain that this is a real displacement.

The chances are about even for and against the apparent displacement of Point Reyes Light-house in 1906, 1.09 meters (3.6 feet), being due simply to errors of observation.



There is about 1 chance in 7 that the apparent displacement of Bodega, shown in table 3, is due to errors of observation. It is reasonably certain that this is a real displacement.

For the remaining six points in group 1, Sierra Morena, Mount Tamalpais, Farallon Light-house, Point Reyes Hill, Tomales Bay, and Sonoma Mountain, each of the apparent displacements given in the tables as observed is real, being in each case clearly beyond the maximum which could be accounted for as errors of observation.

Prof. George Davidson has believed for many years that Mount Tamalpais moved during the earthquake of 1868 and that the triangulations made before and after that date showed such a displacement. Accordingly in 1905, at his request, a reëxamination was made at the Coast and Geodetic Survey office of the evidence furnished by the triangulations, and the conclusion was reached that a real displacement of Mount Tamalpais occurred in 1868. At that time, however, convincing evidence was not discovered that any other triangulation station moved in 1868. In the more extensive studies made in connection with the present investigation, and with the additional skill acquired in recognizing the effects of earthquakes upon triangulation, it became evident, as shown in table 2, not only that Mount Tamalpais moved in 1868, but also that the Farallon Light-house and Ross Mountain moved at that time, the three apparent displacements being clearly beyond the range of possible errors of triangulation. The displacements for these three stations are similar. The amount of the displacement is least at Farallon Light-house, 1.39 meters (4.6 feet), and greatest at Ross Mountain, 1.70 meters (5.6 feet). The azimuth of the displacement is least at the Farallon Light-house,  $153^{\circ}$  ( $27^{\circ}$  W. of N.), and is greatest at Ross Mountain,  $182^{\circ}$  ( $2^{\circ}$  E. of N.). (See map 24.) The apparent differences in direction and amount of the three displacements may or may not be real. It is certain therefore that in 1868 the large part of the earth's surface included between these three stations, at least 700 square miles, moved about 1.5 meters (4.9 feet), in about azimuth  $168^{\circ}$  ( $12^{\circ}$  W. of N.).

Within the triangle defined by the three stations, Mount Tamalpais, Farallon Light-house, and Ross Mountain, which certainly were displaced in 1868, are the three stations, Point Reyes Hill, Tomales Bay, and Bodega, of group 1. It is therefore believed to be reasonably certain that these stations were displaced at that time. The probable displacements were interpolated from the three displacements observed at the first three stations, taking into account the relative positions of the stations. The resulting interpolated displacements are shown in table 2. Other evidence, tending to show that these interpolated values of the displacements are real, will be brought forward later.

For the three stations, Point Reyes Hill, Tomales Bay, and Bodega, the positions were determined before 1868 and after the earthquake of 1906, but not during the interval 1868-1906; hence the computation of the positions determined by triangulation for these stations furnishes simply the combined displacements of 1868 and 1906 as shown in table 3. As noted in the preceding paragraph, the displacement of 1868 has, for these three stations, been interpolated from surrounding stations and entered in table 2. The differences<sup>1</sup> between these inferred displacements in table 2 and the observed combined displacements in table 3 were then taken and are shown in table 1, as inferred displacements in 1906. As indicated in the marked column of table 1, these inferred displacements are believed to be certain for two of these points and somewhat doubtful for the third, Bodega.

The doubtful apparent displacements at Rocky Mound and Red Hill in 1868 (see table 2) agree with other displacements which are certain, in having a decided northward component.

In table 1, showing the displacements of 1906, there are three stations, Sierra Morena, Mount Tamalpais, and Farallon Light-house, at which observed displacement is certain,

<sup>1</sup> The differences were taken separately for the meridian components and the prime vertical components and then combined to secure the direction and amount of the resultant.

and two others. Point Reyes Hill and Tomales Bay, in group 1, at which the displacement inferred from indirect evidence is considered certain. Of these five stations, the four which are to the westward of the fault of 1906 moved northwestward and the one which is to the eastward of the fault, Mount Tamalpais, moved southeastward (see map 24). The displacements of four of the five points were nearly parallel, their azimuths being for Sierra Morena, Point Reyes Hill, and Tomales Bay,  $136^\circ$ ,  $143^\circ$ , and  $142^\circ$  respectively, with a mean of  $140^\circ$  ( $40^\circ$  W. of N.), while that of Mount Tamalpais was  $324^\circ$  ( $36^\circ$  E. of S.). The azimuth of the displacement at the fifth, Farallon Light-house, is  $118^\circ$  ( $62^\circ$  W. of N.) at an angle of about  $22^\circ$  with the other four. The portion of the fault near these points has an azimuth of about  $145^\circ$  ( $35^\circ$  W. of N.), hence the displacement of four of the five points was practically parallel to the fault, the departure being in each case within the range of possible error of the determination of the displacement. For the four points to the westward of the fault, the amounts of the displacement are in the inverse order of their distances from the fault, with the exception of Sierra Morena. For Tomales Bay, which is only 2.1 kilometers (1.3 miles) from the fault, the displacement is greatest, 3.89 meters (12.8 feet), and for the Farallon Light-house, which is 37kilometers (23 miles) from the fault, the displacement is much less, 1.78 meters (5.8 feet).

From these five stations, one may deduce four laws governing the distribution of the earth movement which occurred on April 18, 1906. First, points on opposite sides of the fault moved in opposite directions, those to the eastward of the fault in a southerly direction and those to the westward in a northerly direction. Second, the displacements of all points were approximately parallel to the fault. Third, the displacements on each side of the fault were less, the greater the distance of the displaced points from the fault. Fourth, for points on opposite sides of the fault and the same distance from it, those on the western side were displaced on an average about twice as much as those on the eastern side.

If the proof of these four deduced laws rested upon the evidence of these five stations only, it would be insufficient to convince one. Much other evidence in proof of these four deduced laws will be shown in this report. The laws are here stated in order that they may be kept in mind and tested by the evidence as presented.

The apparent displacements of the remaining five points of group 1 may now be compared with the stated laws.

The displacement of Point Reyes Light-house, believed to be determined with reasonable certainty, is apparently about 1.6 meters (5 feet) greater than and differs about  $32^\circ$  in direction from the displacement which might be inferred from the above laws and comparison with the surrounding stations.

The displacement of Bodega, of which the determination is somewhat doubtful, is just what would be inferred from the deduced laws, as its amount is greater than for Mount Tamalpais, corresponding to the fact that it is closer to the fault, and its azimuth agrees within  $2^\circ$  with that of the fault.

The displacement of Ross Mountain, of which the determination is doubtful, agrees very closely in amount with that at Mount Tamalpais and differs only  $15^\circ$  in direction. Ross Mountain is on the same side of the fault as Mount Tamalpais and at practically the same distance from it.

The apparent displacements of Rocky Mound and Red Hill, 32 and 19 kilometers (20 and 12 miles) from the fault and to the eastward of it, of which the determinations are doubtful, agree with the laws in being small but are contradictory as to direction.

For Sonoma Mountain the triangulation serves to determine the combined displacements of 1868 and 1906 as shown in table 3, but not the separate displacements, as this station was not involved in triangulation done between 1868 and 1906. The combined displacements at Sonoma Mountain are of about the same amount and are in approximately the same azimuth as displacements of 1868 at Mount Tamalpais, Point Reyes Hill, Tomales

Bay, Bodega, and Ross Mountain (see table 2). Some of the internal evidence of computations of triangulation indicate that Sonoma Mountain moved in 1868. According to the general laws of distribution of the earth movement of 1906 as derived from other stations Sonoma Mountain did not move much, if any, being far to the eastward of the fault, 34 kilometers (21 miles). For these three reasons it is believed to be probable that the whole displacement of Sonoma Mountain, 1.24 meters (4.0 feet), in azimuth  $183^{\circ}$  ( $3^{\circ}$  E. of N.), which certainly took place sometime between 1860 and July, 1906, all occurred in 1868.

*Group 2. Southern end of San Francisco Bay.* — In this group there are three new points not yet considered and Red Hill which has already been considered in group 1. The three new stations, Guano Island, Pulgas East Base, and Pulgas West Base (see map 24), were determined in 1851-1854 and again after the earthquake of 1906. No determination was made between 1868 and 1906, hence these points are entered in table 3, the combined displacements of 1868 and 1906 being determined, but not the separate displacements.

A study of the errors of the triangulation shows that the apparent displacement of Guano Island, 0.21 meter (0.7 foot), is probably due to errors of observation, and that there is one chance in three that the apparent displacement of Pulgas East Base, 0.41 meter (1.3 feet), is also due to errors of observation.

The determination of the displacement of Pulgas West Base, 0.74 meter (2.4 feet), is reasonably certain, there being about one chance in twelve that it is due to errors of observation.

Tho the determinations of the separate apparent displacements of Red Hill in 1868, 0.65 meter (2.1 feet), and in 1906, 0.30 meter (1.0 foot), are each doubtful, the combined displacement as observed, shown in table 3, 0.94 meter (3.1 feet), is certain.

It is therefore reasonably certain that there was a relative displacement of Pulgas West Base and Red Hill as indicated in table 3, Red Hill moving 0.94 meter (3.1 feet), in azimuth  $227^{\circ}$  ( $47^{\circ}$  E. of N.), and Pulgas West Base 0.74 meter (2.4 feet), in azimuth  $344^{\circ}$  ( $16^{\circ}$  E. of S.). This lengthened the line Pulgas West Base to Red Hill, 16 kilometers (10 miles) long, 0.50 meter (1.6 feet), or one part in 32,000. It also changed the azimuth of this line by  $11''$ , from  $240^{\circ} 44' 35''$  to  $240^{\circ} 44' 24''$ , rotating it in a counterclockwise direction.

The red arrows on map 24, showing apparent displacements, indicate that the apparent displacements of Guano Island and Pulgas East Base, which are considered doubtful, are not inconsistent with the displacements of Red Hill and Pulgas West Base. Apparently the area included between these four stations was distorted by stretching and rotated in a counterclockwise direction.

There is no evident method of ascertaining whether the displacement of Pulgas West Base took place in 1868 or 1906 or in part at each time. The displacement is nearly in the direction corresponding to the laws governing the displacements of 1906, as already stated in connection with group 1. Pulgas West Base is to the eastward of the fault of 1906 and slightly nearer to it than Mount Tamalpais and Ross Mountain and hence, according to the laws referred to, should be displaced in the same direction as these two points (see table 1), and by a similar amount. This is the fact.

*Group 3. Vicinity of Colma.* — There are nine points in group 3 all determined by triangulation in 1899 or earlier, and redetermined after the earthquake of 1906 (see table 1). The earlier determination was made by secondary and tertiary triangulation, extending from the vicinity of Pulgas Base northwest, spanning San Francisco Bay to the Golden Gate, and thence southward to Colma. The earlier positions of these nine points are subject to the effect of accumulated errors in this chain of triangulation about 60

kilometers (40 miles) long. They are subject, therefore, to an error of position common to them all, which may be as great as 7 meters (23 feet). With the exception of Montara Mountain Peak and Bonita Point Light-house these points are all within 13 kilometers (8 miles) of San Bruno Mountain and therefore their relative positions were determined with considerable accuracy.

In the triangulation of 1906-1907, the position of San Bruno Mountain, which is in the midst of this group, was determined by secondary triangulation in connection with group 2 as indicated on maps 24 and 25, a direct and strong determination. The new azimuth was also carried into the triangulation of group 3 with a high degree of accuracy in this same manner. No new determination was made of the starting length in group 3. It was assumed that the length San Bruno Mountain to Black Ridge 2 had remained unchanged during the earthquake of 1906 and the old value of that length was used in the computation of the triangulation of 1906-1907. As a check upon the assumption that this length remained unchanged, it is to be noted that the azimuths of this line before and after the earthquake of 1906 were found to differ only by 9.3", which is within the possible range of errors of observation in the earlier triangulation.

For the reasons stated above, the apparent absolute displacements shown in table 1 for group 3, as referred to Mocho and Mount Diablo as fixt points, are probably due to errors of observation.

On account, however, of the fact that seven of the nine points in this group are within a rather small area, their relative displacements are determined with considerable accuracy, the errors of length and azimuth having less effect in producing errors in relative positions, the smaller the area covered by a triangulation. Montara Mountain Peak and Bonita Point Light-house are each determined with a low grade of accuracy. They are each far from the stations occupied in the triangulation and the lines which determine them intersect at a small angle; hence even their relative displacements are uncertain. The relative displacements observed for the remaining seven points after omitting these two are certain, being beyond the possible range of errors of observation.

The apparent absolute displacements for this group of points (see table 1 and map 25) indicate that all points on the eastern side of the fault moved in a southerly direction, and those on the western side in a northerly direction; that the displacements tend to be parallel to the fault, the more doubtful displacements showing the greater angles with the fault; and that the amounts of the displacement are in the inverse order of the distances of the stations from the fault, with two exceptions. These exceptions are San Pedro Rock, of which the relative displacement is determined with sufficient accuracy to establish this as a real exception; and Bonita Point Light-house, for which the apparent displacement as observed is so uncertain that this apparent exception has but little significance. Of the four points, all on the western side of the fault, of which the relative displacements are believed to be certain, as indicated in table 1, the azimuths of the displacements vary from 151° to 169°, with a mean of 157° (23° W. of N.). The azimuth of the fault in this vicinity is 144° (36° W. of N.).

The relative displacements on opposite sides of the fault and near to it are less in this group (2 to 3 meters) than for points at a similar distance from the fault in group 1; namely, Point Reyes Hill, Tomales Bay, and Bodega (5 to 6 meters).

*Group 4. Tomales Bay.* — There are seven points in this group (see tables 1 to 3 and maps 24 and 25). These were fixt in 1856-1860 by tertiary triangulation extending southeastward along Tomales Bay from stations Tomales Bay and Bodega of group 1. They were fixt again in practically the same manner in 1906 after the earthquake.

With these seven points may advantageously be considered the three points, Point Reyes Hill, Tomales Bay, and Bodega, which were fixt in group 1.

No one of these ten points was determined between 1868 and 1906, hence the observations served to determine the combined displacements of 1868 and 1906, as shown in table 3, but not the separate displacements. The separate displacements have been determined by interpolation from surrounding stations for the three points, Point Reyes Hill, Tomales Bay, and Bodega, as indicated in the discussion of group 1. The same process has also been applied to the seven points of group 4.

Starting *with*, the interpolated displacements of 1868 for the three points, Point Reyes Hill, Tomales Bay, and Bodega, as shown in table 2, and with map 25 before one, it was a simple matter to interpolate separately the meridian components and the prime vertical components of the displacements of 1868 for the seven stations of group 4. This amounts practically to interpolating the displacements for these points from the three observed displacements of 1868 at Mount Tamalpais, Farallon Light-house, and Ross Mountain. The resulting interpolated displacements of 1868 are shown in table 2. Each of these being subtracted, component by component, from the corresponding combined displacement of 1868 and 1906, as shown in table 3, leaves the displacement of 1906 as shown in table 1.

A study of the possible accumulated errors in the triangulations shows that all of the seven displacements of 1906 in group 2 are certain except for Hans and Hammond. There is about one chance in five that the apparent-displacements of 1906 for these two points are simply due to errors of observation.

The ten displacements of 1906 in this group show clearly the four laws already suggested in regard to such displacements. All points to the eastward of the fault moved southerly and those of the western side, northerly. Four of the five points to the westward of the fault moved in azimuths between  $141^{\circ}$  and  $143^{\circ}$  with a mean of  $142^{\circ}$  ( $38^{\circ}$  W. of N.). The azimuth of this part of the fault is about  $145^{\circ}$  ( $35^{\circ}$  W. of N.). The azimuth of the fifth displacement on the west side, at Bodega Head, is  $172^{\circ}$  ( $8^{\circ}$  W. of N.). The azimuths of the three reasonably certain displacements of points to the eastward of the fault vary from  $323^{\circ}$  to  $348^{\circ}$  with a mean of  $334^{\circ}$  ( $26^{\circ}$  E. of S.), which is within  $9^{\circ}$  of being parallel to the fault. Of the five points to the westward of the fault, the one nearest to the fault, Foster, has the greatest displacement. The other four, all between 2.0 and 2.7 kilometers from the fault, have nearly equal displacements. The five displacements for points to the eastward of the fault show a slight tendency to stand in inverse order from the distances from the fault. But one only of these displacements differs by more than 0.42 meter (1.4 feet) from the mean of the five, and the estimated distances from the fault vary only from 0.5 to 2.6 kilometers. When the uncertainty of the position of the fault beneath Tomales Bay is considered, as well as the small variation in distance of these ten points from the fault, difficulties are to be expected in detecting the relation between displacement and distance from the fault in this group. The mean displacement of the points to the eastward of the fault is 1.86 meters (6.1 feet) and of the five points to the westward 2.1 times as much, namely, 3.88 meters (12.7 feet).

*Group 5. Vicinity of Fort Ross.*—There are twelve points in this group, all determined by secondary triangulation in 1875-1876 and again in 1906, the scheme of triangulation being in each case substantially the same as that shown on map 25. The base from which these positions are determined is not independent of observations made before 1808, but is gotten by making the observations preceding that date conform to those made between 1868 and 1906. From the small size of the necessary corrections to the observed angles, and from the fact that the position of Ross Mountain, which predominates the group, is determined by observations made entirely after 1808, the error of assuming that these twelve points belong to the period between 1808 and 1900 is deemed negligible.

For one point, Chaparral, observations made in 1860 furnish a determination, of the position before 1868, and hence the displacement of this point in 1868 (see table 2) is determined as well as its displacement in 1906. The displacement of 1868 agrees closely, within less than 0.13- meter (0.4 feet) in amount and 9° in direction, with the displacement at that time at Ross Mountain, 5.7 kilometers (3.5 miles) to the eastward.

A study of the possible accumulated errors in the triangulation shows that five of the observed displacements in this group, as referred to Mocho and Mount Diablo, are clearly beyond the range of possible errors of observation; namely,, those at Fort Ross, Funcke, Timber Cove, Stockhoff, and Pinnacle Rock. For the remaining seven displacements, there are from one to two chances out of ten that they are due entirely to errors of observation, and these displacements are therefore reasonably certain. The relative displacements of pairs of points on opposite sides of the fault and near to each other in this group are certain, being in every case clearly beyond the range of possible errors of observation.

The apparent displacements in 1906 of the twelve points in this group conform closely to the four deduced laws governing such displacements. The seven points to the westward of the fault moved in a northerly direction, in azimuth varying from 137° to 158°, with a mean of 144° (36° W. of N.). The azimuth of the fault in this region is about 141° (39° W. of N.). All five points to the eastward of the fault moved southerly, in azimuth varying from 301° to 328° with a mean of 318° (42° E. of S.). All of the points in this group are within 3.2 kilometers (2.0 miles) of the fault and therefore give little opportunity to ascertain whether the amounts of the displacements show any relation to distances from the fault. Such a relation is not clearly discernible among the observed displacements. The evidence of the apparent displacement at Ross Mountain (see table 1), 6.2 kilometers (4.2 miles) to the eastward of the fault, indicates a decrease of displacement with increase of distance from the fault in that direction. The average displacement of the five points to the eastward of the fault is 1.44 meters (4.7 feet) and that of the seven points to the westward is 1.5 times as great, namely, 2.11 meters (6.9 feet).

*Group 6. Point Arana.* — In this group there are ten points determined by secondary triangulation in 1870 to 1892 that were redetermined by secondary triangulation in 1906, starting from the stations Fisher and Cold Spring, 11.2 and 13.5 kilometers eastward from the fault respectively. (See map 25.) A study of the possible errors in the triangulation shows that all of the observed displacements in this group are certain, each being clearly greater than the maximum possible errors of observation. There is a possibility that the assumption that the two stations, Fisher and Cold Spring, remained unmoved in 1906 is in error. The movement, if any, of these stations was probably about the same for both stations and in a southerly direction and parallel to the fault. If such a movement of these stations occurred, the computed displacements in 1906, shown in table 1 and on map 25, are all too small for stations to the eastward of the fault, and too great for stations to the westward of it.

The agreement of the observed displacements of the ten points in this group with the four deduced laws is close. The six points to the westward of the fault moved in azimuths varying thru a range of 5° only, from 159° to 164°, with a mean of 162° (18° W. of N.). The fault in this vicinity is said to change in azimuth, near the point where it crosses the coast-line, from about 144° to about 164° (16° W. of N.), curving to the eastward. The four points to the eastward of the fault moved in azimuths varying from 324° to 340° with a mean of 330° (30° E. of S.). The station Shoemake, comparatively near to the fault, 1.5 kilometers (0.9 mile), on the west side, showed a displacement much larger than any of the other five points on that side, all of which are from 5.7 to 7.6 kilometers from the fault. The two points to the eastward of the fault which are within less than 1 kilometer of it were displaced nearly twice as much as the other two which are nearly 4 kilometers from the fault. The average displacement for the four points to the east-

ward of the fault is 1.16 meters (3.8 feet) and for the six to the westward is 2.3 times as great, namely, 2.71 meters (8.9 feet).

*Group 7. Southern part of primary triangulation.*— In this group, extending southward from the line Mocho-Sierra Morena, there are nine points (see map 24) of which the positions were redetermined after the earthquake of 1906. Of these, one, Loma Prieta, had been formerly determined both before and after the earthquake of 1868; five others had been determined before 1868 but not after, and three had been determined after but not before 1868. (See tables 1 to 3.) In this group, therefore, but one point is available to show the displacement of 1868.

The triangulation of 1854-1855, starting from the line Ridge to Rocky Mound near the Pulgas Base, consisted of a single chain of triangles with all angles measured, down to the line Loma Prieta-Gavilan. The Point Pinos Light-house and the Point Pinos Latitude Station were connected with this chain, and with checks, by observations in 1854, 1864, and 1866.

The main triangulation of 1876-1887, from the line Mount Diablo-Mocho to the line Mount Toro-Santa Ana, consisted of a strong chain of figures with many checks, being substantially as shown on map 24 if Gavilan be omitted and all stations occupied. In this triangulation, however, no complete independent determinations with checks were made of Black Mountain, Santa Cruz Azimuth Station, Gavilan, Point Pinos Light-house and Point Pinos Latitude Station.

The triangulation of 1906-1907 was made as shown on map 24. Two separate least square adjustments were made of the main scheme connecting the points Mount Diablo, Mocho, Sierra Morena, Loma Prieta, Mount Toro, Gavilan, and Santa Ana.

In the first adjustment, it was assumed, as for the computations of other groups, that Mount Diablo and Mocho only remained unmoved during the earthquake of 1906. This first adjustment showed an apparent displacement of Santa Ana in 1906 of 3.26 meters (10.7 feet), in azimuth  $288^{\circ}$  ( $72^{\circ}$  E. of S.), but an examination in detail of the possible accumulated errors in the triangulation showed that this apparent displacement was probably due to errors of observation. The new primary triangulation is much weaker in the figure defined by the five points, Mocho, Loma Prieta, Mount Toro, Gavilan, and Santa Ana, than elsewhere for two reasons. First, the length must be carried without a check thru the triangle Loma Prieta, Mocho, Mount Toro, of which only two angles were measured and this triangle is very unfavorable in shape for an accurate determination of length. Second, it so happened that the least accurate observations made in the primary triangulation were in this triangle or in its immediate vicinity.

In the second and adopted adjustment it was assumed that Santa Ana, as well as Mount Diablo and Mocho, remained unmoved during the earthquake of 1906. The astronomic azimuth had been observed at Mount Toro in 1885 and again after the earthquake of 1906. These two observations measured the absolute change in azimuth of the line between Mount Toro and Santa Ana and indicated it to be 2.5", the later azimuth being the greater. This was utilized to strengthen the adjustment.

In view of the evidence of stations farther north, the assumption that Santa Ana remained unmoved is reasonably safe. Santa Ana is about 27 kilometers (17 miles) to the eastward from the point at which the fault disappeared near the village of San Juan. There is no station anywhere in the triangulation more than 6.4 kilometers to the eastward of the fault for which any displacement in 1906 was determined with certainty.

If Santa Ana was displaced in 1906, the erroneous assumption introduces an error into the computed displacements at the stations Gavilan, Mount Toro, Point Pinos Light-house, and Point Pinos Latitude Station, of about the same amount as the actual displacement at Santa Ana. The error produced in the computed displacement at Santa Cruz Light-house and Santa Cruz Azimuth Station must be much smaller, and no error

would be produced at Loma Prieta. Taking the uncertainty in regard to the estimated stability of Santa Ana into account as well as the possible errors in the triangulation, the following estimates of the uncertainties of the apparent displacements were made.

The displacements of Loma Prieta in 1906 and 1868 (see tables 1 and 2) are both certain.

The displacements of Black Mountain, Santa Cruz Azimuth Station, Gavilan, Point Pinos Light-house, and Point Pinos Latitude Station, as shown in table 3, are also certain. These are all combined displacements of 1868 and 1906. These stations were not determined between 1868 and 1906, hence it is not possible to determine directly from the observations the separate displacements. If it be assumed that the displacements in 1868 of the last four of these points were the same as that observed for Loma Prieta (see table 2), then the inferred displacements for each of these points in 1906 is as shown at the end of table 1. These inferred displacements for these points are, however, very doubtful as they depend upon a determination of the displacement of 1868 at a single point, Loma Prieta, which is 24 kilometers (15 miles) from Santa Cruz Azimuth Station and more than 48 kilometers (30 miles) from each of the other stations. It should be noted also that the displacement of Loma Prieta in 1868, which is certain, is very different from that of the other four points, Mount Tamalpais, Farallon Light-house, Chaparral, and Ross Mountain, for which the displacements of 1868 have been determined directly by observations. It is a displacement to the southward instead of to the northwestward and is much larger than for the other three points.

The determination of the displacement of Mount Toro as shown in table 1 is somewhat uncertain. There is still more uncertainty in regard to the apparent displacement at Santa Cruz Light-house.

The very small apparent displacement, 0.12 meter (0.4 foot), of the Lick Observatory small dome in 1906 is probably due to errors of observation.

The two points in this group to the eastward of the fault show apparent displacements in 1906 in accordance with the laws deduced from other groups: Lick Observatory, far from the fault, 36 kilometers (22 miles), having an apparent displacement so small as to be uncertain; and Loma Prieta, within 4.8 kilometers (3.0 miles) of the fault, having an apparent displacement of 0.97 meter (3.2 feet) in a southerly direction and within  $9^\circ$  of being parallel to the fault which here has an azimuth of about  $312^\circ$  ( $48^\circ$  E. of S.).

Mount Toro is the only station to the westward of the fault in this group for which a determination of the displacement of 1906 is not very doubtful. The displacement in 1906 of 0.95 meter (3.1 feet) at Mount Toro is in a northerly direction with a slight inclination to the westward in fair agreement with the deduced laws. Mount Toro is beyond the end of the portion of the great fault of 1906 which has been traced on the surface.

The apparent displacement of Santa Cruz Light-house in 1906, of which the determination is doubtful, is closely parallel to the fault and in a northerly direction, corresponding to other points to the westward of the fault.

The inferred displacements of 1906 for four points shown at the end of table 1 are all very doubtful, and little significance should be attached to them or to the fact that they are somewhat contradictory to each other and all have a southerly tendency, whereas all other points to the westward of the fault of 1906 moved in a northerly direction. As a check on this conclusion, it should be noted that the inferred displacement for 1900 for Santa Cruz Azimuth Station differs by  $72^\circ$  in direction and 1.26 meters (4.1 feet) in amount from the observed displacement of 1906 for Santa Cruz Light-house, a point only 3.9 kilometers (2.4 miles) away. The observed displacement for Santa Cruz Light-house is much less uncertain than the inferred displacement for Santa Cruz Azimuth Station and hence the contradiction throws additional doubt on the latter and the other three points for which the inference is made in like manner.



Tho the inferred displacements of these four points for 1906 are all very doubtful, the observed combined displacements of 1868 and 1906 for these four points, as shown in table 3, are all certain, being clearly beyond the possible range of errors of observation. So also are the combined displacements of 1868 and 1906 for Loma Prieta and Black Mountain. It appears then that the combined effects of the earthquakes of 1868 and 1906 were to move the whole region from Black Mountain to Point Pinos to the southeastward by from 2.11 to 5.89 meters (6.9 to 19.3 feet). The mean azimuth of these six displacements is  $321^\circ$  ( $39^\circ$  E. of S.). The most startling evidence of the combined effects of the two earthquakes is the increase of 3 meters (10 feet) in the width of Monterey Bay from Santa Cruz Azimuth Station to Point Pinos Light-house, both of these points having moved in a southerly direction, but the latter much more than the former. The length of the line Santa Cruz Azimuth Station to Point Pinos Light-house is only 39.8 kilometers (24.7 miles). The increase is therefore one part in 13,000.

Not much significance should be attached to the fact that Point Pinos Latitude Station has apparently moved one meter less than Point Pinos Light-house. This one meter is the difference of the combined displacements of two earthquakes. It is subject to the errors of observation in two determinations of each point by triangulation in somewhat different ways. Moreover, the determination of the position of the Latitude Station after the earthquake of 1906 was made without a check. It is for this reason that the displacement at Point Pinos Light-house is considered to be the more reliable determination of the two.

#### DISTRIBUTION OF EARTH MOVEMENT, SUMMARY.

In reaching the conclusions stated below, the evidence has been studied much more in detail than it has been given in the preceding pages. The conclusions are based on both the positive and negative evidence. The positive evidence is given by the displacements marked "certain" or "reasonably certain" in tables 1, 2, and 3. The negative evidence is given by displacements marked "doubtful," of which Rocky Mound is an example. At this point the observed apparent displacement of 1906 was only 0.34 meter (1.1 feet). The accuracy of the triangulation is such that it is practically certain that any displacement of this station as great as one meter would be detected. Hence the evidence given by this station is that the displacement, if any, was less than one meter and probably was less than 0.3 meter.

Maps 24 and 25 should be consulted while reading the following conclusions.

During an earthquake in 1868 or about that time, about 1,000 square miles of the earth's crust, comprized between the four stations Mount Tamalpais, Farallon Light-house, Ross Mountain, and Chaparral, were permanently displaced to the northward about 1.6 meters (5.2 feet), in azimuth  $169^\circ$  ( $11^\circ$  W. of N.). The indications are that this whole area moved as a block without distortion or rotation; at least the triangulation furnishes no evidence competent to prove either distortion or rotation of the block (about a vertical axis), or to locate accurately any boundary of the block. It is probable that the block included Sonoma Mountain. It is reasonably certain that Rocky Mound and the group of points near the southern end of San Francisco Bay, Red Hill, Pulgas Base stations, and Guano Island, were not on this block, tho they were probably displaced somewhat irregularly during the earthquake of 1868.

During the earthquake of 1868, or about that time, Loma Prieta was permanently displaced about 3.03 meters (9.9 feet), in azimuth  $307^\circ$  ( $53^\circ$  E. of S.). This displacement is in a direction at an angle of  $138^\circ$  with that of displacements of same date, referred to in the preceding paragraph. Loma Prieta moved to the southeastward, whereas Mount Diablo, Farallon Light-house, Ross Mountain, and Chaparral moved to the northward.

It is reasonably certain that Santa Cruz Azimuth Station, Point Pinos Light-house, Point Pinos Latitude Station, and Gavilan were similarly displaced. It is probable that the last

three stations named were displaced to the southeastward in 1868, being about 3 meters (10 feet) more than Santa Cruz Azimuth Station and Loma Prieta, and consequently the width of Monterey Bay was increased then by about one part in 13,000.

The combined effects of the earthquakes of 1868 and 1906 have increased the distance between Mount Tamalpais and Black Mountain, see map 24 and table 3, by 3 meters (10 feet). The distance is 79 kilometers (49 miles) and the increase is therefore one part in 26,000. The Golden Gate lies between these two stations. It is interesting to note that the length of part of the Pacific Coast including the Golden Gate has been increased just as the distance across Monterey Bay has been increased.

During the earthquake of April 18, 1906, displaced points on opposite sides of the great fault accompanying the earthquake moved in opposite directions, those to the eastward of the fault in a southerly and those to the westward in a northerly direction. Among all the points there are but two apparent exceptions to this rule, namely, Rocky Mound and Red Hill. For both these stations the apparent exceptional movement is so small as to be probably due simply to errors of observation and therefore it is not significant.

During the earthquake of 1906, the permanent displacements of all disturbed points were approximately parallel to the fault. When the difficulties encountered in determining the direction of these displacements are considered, it is remarkable that the observed displacements follow this law so accurately as they do. The nearest fixed points to which each displaced point is referred are from 30 to 140 kilometers distant (20 to 90 miles). The total displacements are from 0.5 to 4.6 meters (2 to 15 feet). Among all the points examined, there are but five for which the apparent changes in distance from the fault are not so small as to be probably due to errors of observation. The Farallon Light-house apparently moved at an angle of about  $27^\circ$  with the fault and its increase in distance from the fault of 0.8 meter is reasonably certain. As Mount Tamalpais, nearly opposite to Farallon Light-house across the fault, moved practically parallel to the fault, there was either an opening of the fault beneath the sea in this region or an increase in length of the earth's crust, in a direction at right angles to the fault, of one part in 50,000 (0.8 meter on 44 kilometers, or 3 feet on 27 miles). Point Reyes Light-house also apparently receded from the fault, moving in about the same direction (within  $5^\circ$ ) as the Farallon Light-house, but the determination of the displacement of the Point Reyes Light-house is so weak that this apparent displacement has little significance. It is reasonably certain that Bodega Head approached the fault from the western side, while Bodega, on the eastern side of the fault, about opposite, moved parallel to the fault. The apparent closing up of the fault or shortening of the crust at right angles to the fault is 1.6 meters (5.2 feet) between these two points only 5.4 kilometers (3.4 miles) apart. This is one part in 3,400. It is possible that as much as one-half of this apparent closing up is due to errors of observation, but it is reasonably certain that not all of it is due to that cause. Similarly it is reasonably certain that Peaked Hill in the Fort Ross group receded from the fault on the east side and Pinnacle Rock approached it on the west side, the apparent amounts being 0.4 meter (1.3 feet) and 0.7 meter (2.3 feet) respectively. It is reasonably certain that San Pedro Rock in the Colma group approached the fault from the west side, the apparent amount being 1.1 meters (3.6 feet).

During the earthquake of 1906, the displacements on each side of the fault were less the greater the distance of the displaced points from the fault. On the eastern side of the fault, ten points at an average distance of 1.5 kilometers (0.9 mile) from the fault have an average displacement of 1.54 meters (5.1 feet); three points at an average distance of 4.2 kilometers (2.0 miles) have an average displacement of 0.86 meter (2.8 feet), and one point, Mount Tamalpais, at 6.4 kilometers (4.0 miles) from the fault, has a displacement of 0.55 meter (1.9 feet). These fourteen points are the only ones on the eastern side of the fault for which the observed displacements were determined with reasonable certainty. For no point to the eastward of the fault at a greater distance than 6.4 kilometers (4.0

miles) was any displacement detected with certainty. To the westward, twelve points at an average distance of 2.0 kilometers (1.2 miles) from the fault have an average displacement of 2.95 meters (9.7 feet). Seven at an average distance of 5.8 kilometers (3.6 miles) have an average displacement of 2.38 meters (7.8 feet). The only other point to the westward of the fault of which the displacement was determined with certainty was Farallon Light-house, distant 37 kilometers (23 miles) and displaced 1.78 meters (5.8 feet).

In receding from the fault, either to the eastward or to the westward, the displacement decreases more rapidly near the fault than it does farther from the fault. According to the averages given in the preceding paragraph, the decrease in displacement on the eastern side near the fault is at the rate of 0.25 meter per kilometer (that is, 0.68 meter on 2.7 kilometers) and farther away the rate is 0.13 meter per kilometer (that is, 0.28 meter on 2.2 kilometers). Imagine a straight line before the earthquake of April 18, 1906, starting at the fault and extending eastward at right angles to it. According to this investigation, after the earthquake this line became a curved line concave to the southward, the point at the fault being displaced southward and distant points on the line remaining fixed. Also according to the above figures, the part of the line which is from 1.5 to 4.2 kilometers from the fault was deflected from its former direction about 52 seconds and that part from 4.2 to 6.4 kilometers from the fault was deflected about 26 seconds, and the deflection probably decreased gradually to zero at distant points. To the westward of the fault the rate of decrease of displacement, according to the averages in the preceding paragraph, near the fault is 0.15 meter per kilometer (that is, 0.57 meter on 3.8 kilometers), and farther away only 0.02 meter per kilometer (that is, 0.60 meter on 31 kilometers). Accordingly the imaginary straight line at right angles to the fault and extending westward from it has become concave to the northward, the point at the fault being displaced to the northward and very distant points remaining fixed. The deflection from its original direction is about 31 seconds for the part from 2 to 6 kilometers from the fault and about 4 seconds on an average for the part from 6 to 37 kilometers from the fault.

For points on opposite sides of the fault of 1906, and at the same distance from it, those on the westward side are displaced on an average twice as much as those on the eastern side. This statement applies especially to points within 10 kilometers (6 miles) of the fault. For points farther away, the ratio becomes more than two to one. It is important to note that this statement applies to displacements, not distortions. The distortion, expressed in angular measure, discussed in the preceding paragraph, is nearly the same on the two sides of the fault, being somewhat less close to the fault on the western side than on the eastern side.

The amount of relative displacement of the two sides of the fault by sliding along the fault, as detected by the triangulation, shows no variations for different parts of the fault along its whole length from Point Arena to San Juan, with one exception, which are sufficiently large to be clearly not due to errors of observation. This exception is the region near Colma where, as already noted, relative displacements seem to be unusually small.

The permanent displacements and distortions which took place at the time of the earthquake of April 18, 1906, may be pictured by imagining a series of perfect squares drawn on the surface of the ground before the earthquake, with their sides parallel and perpendicular to the fault. At the time of the earthquake every square to the eastward of the fault moved bodily in a southerly direction parallel to the fault, the squares more distant from the fault moving less than those near to it. All sides of squares parallel to the fault remained straight lines, unchanged in length and direction. For the squares to the eastward, the sides perpendicular to the fault became curved lines concave to the southward and changed direction as a whole by rotation in a counterclockwise direction, the change being 52 seconds or more for squares near the fault, and less for more remote squares\*. The angles of the squares all took new values differing from  $90^\circ$  by quantities

ranging from more than 52 seconds to zero. The squares to the westward of the fault were moved bodily in a northerly direction parallel to the fault, their sides parallel to the fault remaining straight and unchanged in length and direction. Their sides perpendicular to the fault became curved lines concave to the northward and each changed in direction by rotation in a counterclockwise direction, the change being more than 31 seconds for squares near the fault and less for more remote squares. The displacement of squares near the fault was twice as great for squares on the western side as for squares on the eastern, but the distortion was slightly less for squares on the western side than for those on the eastern side. The appreciable displacements extended back much farther from the fault on the western side than on the eastern side.

It is not probable that the actual displacements and distortions were perfectly regular as indicated in the word picture of the preceding paragraph, but the apparent departures from this perfectly regular ideal, of the displacements and distortions detected by the triangulation are nearly all so small as to be possibly due to errors of observation. Attention has been called to the few exceptions, of which one can be certain, which have been detected. The earth-movements of April 18, 1906, were remarkable for their regularity of distribution.

The triangulation of 1906-1907 has extended eastward clearly beyond the region of appreciable permanent displacements by the earthquake of 1906. The disturbed region evidently extended to the westward out under the Pacific beyond the possible reach of the triangulation. To the northward of Point Arena there is little probability of much success if an attempt were made to determine additional displacements by triangulation, for the known fault of 1906 touches the coast for but a short distance anywhere north of Point Arena, and triangulation to the northward of Point Arena before the earthquake consisted simply of a narrow and weak belt of tertiary triangulation. It had been intended to extend the triangulation of 1906-1907 far enough to the southward to reach outside of the disturbed region. It was supposed until after the observing party left the southern end of the triangulation that this had been accomplished, but when the additional evidence given by the office computations became available, it was evident that the most southern points determined are still within the disturbed region. The fact that the visible evidence of the fault of 1906 does not extend farther southward than San Juan indicates that there are probably few points to the southward of Mount Toro and Point Pinos for which the displacements were large enough to be detected by triangulation.

#### DISCUSSION OF ASSUMPTIONS.

Certain things have apparently been assumed in this investigation; for example, that appreciable permanent displacements occurred during the earthquake of 1868 as well as during the earthquake of 1906; that the permanent displacements in 1906 occurred suddenly, and that the stations Mocho and Mount Diablo remained unmoved in both earthquakes.

These are called apparent assumptions because in a real sense they are not assumptions but are instead facts detected gradually in studying for fifteen months upon a steadily increasing mass of evidence. However, treating them as assumptions, their validity has been reexamined in the light of all the evidence, and to make this report complete, it is now necessary to state why they are believed to be true.

It has been tacitly assumed that the permanent displacements of 1906, detected by the triangulation, took place suddenly. It is certain from evidence entirely distinct from the triangulation that on April 18, 1906, relative displacements by sliding along the great fault of that date took place suddenly, that is, within an interval of a few seconds, without much crushing or separation of the sides of the fault, and that these relative displacements;

amounted from 2 to 6 meters (7 to 20 feet). These relative-displacements were evident at every road, fence, or line of trees crossing the fault, but such evidence does not enable one to ascertain how far back from the fault in each direction the displacement extended. The repetition of the triangulation after the earthquake showed that many points at various distances from the fault had all been displaced parallel to the fault, that the distribution of the displacements is regular, and that for points nearest the fault, the relative displacements corresponded in amount to those observed at roads; fences, tree lines, etc., at the fault and which were known to have taken place suddenly. Hence it is certain that the widely distributed displacements shown by the triangulation are a part of the same phenomenon and took place at the same time as the displacements at the fault, that is, suddenly on April 18, 1906.

For the displacements credited to the year 1868 in this report, the cases differ. It had been known from previous examination of the evidence given by triangulation that Mount Tamalpais had moved between 1859 and 1876. In the course of the detailed studies of the triangulation in connection with the present investigation, it was found that other triangulation stations had moved at or about 1868. It was discovered that wherever triangulation in this part of California before 1868 had been connected with triangulation done after 1868, it was necessary, in order to obtain consistent results, to apply abnormally large corrections to the observed angles. By trial it was found that wherever the observations of angles were separated into two groups and separate computations made connecting identical points marked upon the ground, one group comprising observations before 1868 and the other observations after that year, that the corrections necessary to obtain consistent results from each set of angles were much smaller than before, and about the normal size to be expected from the instruments and methods of observation used. The evidence proves that permanent displacements took place at or about 1868 of a magnitude which the triangulation could detect with certainty. The particular year in which the displacements took place is not fixed, however, by the triangulation, but simply the fact that they occurred within the interval of several years which elapsed in each part of the triangulation between the last observation before 1868 and the first observation after that year. For this reason considerable care has been taken in stating the dates of the triangulation for each locality. In 1906, it was known that sudden permanent displacements took place on a certain day, hour, and minute along a great fault-line and these displacements were similar to those detected later by triangulation. So far as the writers know, no evidence has been found that such large sudden relative displacements took place in 1868 or about that year, but it is known that a very severe earthquake in this region occurred in 1868. Hence the observed displacements, referred in this report to 1868 for the sake of brevity, may have occurred in some other year near 1868 and may have occurred by a gradually creeping motion extending over several years.

No other abnormal discrepancies in the triangulation within this region are known to exist. If there are such discrepancies, produced by displacements of the triangulation stations by earthquakes, they are so small as to be effectually masked by the unavoidable errors of observation. In other words, any other permanent horizontal displacements by earthquakes within this region between 1850 and 1907 must have been much smaller than the displacements of 1906 and 1868.

It has been assumed that there was no permanent displacement of stations Mocho and Mount Diablo during the earthquake of 1906. What is the evidence that this assumption is true?

The true direction or azimuth from Mocho to Mount Diablo was determined by observations upon the stars in 1887 and found to be  $144^{\circ} 57' 35.71''$ . In 1907 it was redetermined by observations upon the stars and found to be  $144^{\circ} 57' 35.66''$ , differing by only  $0.05''$ .

from its former value. The maximum possible difference between the two determinations of azimuth which could occur simply as errors of observation is about 1".<sup>1</sup> Hence these observations show positively that the true direction from Mocho to Mount Diablo had not changed between these dates by as much as 1" and probably had not changed by as much as 0.3".

The true direction or azimuth of the line Mount Tamalpais to Mount Diablo was determined by observations upon the stars in 1882 and again in the same manner in 1907. In 1882 it was found to be  $274^{\circ} 15' 15.04''$  and in 1907,  $274^{\circ} 15' 14.49''$ , 0.55" less than before. The azimuth of the line Mount Tamalpais to Mount Diablo was computed separately from the triangulation between 1868 and 1906, and from the triangulation after the earthquake of 1906 and the two values found to be  $274^{\circ} 15' 19.46''$  and  $274^{\circ} 15' 17.89''$  respectively, the second being 1.57" less than the first. This apparent decrease of azimuth as determined by the triangulation agrees within 1.02" with the decrease of 0.55" determined independently by astronomic observations.<sup>2</sup> This agreement is within the range of possible errors of observation. In the two computations of the triangulation, the line Mocho-Mount Diablo was assumed to have the same azimuth before and after April 18, 1906; hence the close agreement noted indicates that the azimuth Mocho-Mount Diablo remained unchanged.

In the investigation which has been made, it was found that the absolute displacement decreased with increased distance from the fault and that no displacement sufficiently large to be detected with certainty was found farther to the eastward of the fault than Mount Tamalpais, 6.4 kilometers (4.0 miles) from it. Mocho and Mount Diablo are 53 kilometers (33 miles) from the fault; hence it seems certain that the displacements, if any, at Mocho and Mount Diablo must have been extremely small. It may be objected that this is reasoning in a circle, inasmuch as the computed displacements depend upon the assumption that Mocho and Mount Diablo stood still. Cleared of this objection, the argument reduces to the following. The triangulation shows no relative displacements in 1906, large enough to be determined with certainty, of Mocho, Mount Diablo, Rocky Mound, Red Hill, and Lick Observatory, a group of points far to the eastward of the fault, whereas many points nearer to the fault showed large relative displacements as referred to each other, with a marked tendency to be greater the nearer to the fault are the groups of points compared. Hence the reasoning is valid that Mocho and Mount Diablo remained unmoved, these being two points in a group showing no displacements relative to each other, the whole group being far from the fault and these two particular stations being the two points most distant from the fault.

If either Mocho or Mount Diablo had moved in April, 1906, in such a direction as to decrease (or increase) the azimuth of the line joining them, the effect of the erroneous assumption, used in the computation of the triangulation done after the earthquake that the azimuth had remained unchanged, would have been to produce a set of computed apparent displacements which would be represented by red arrows on map 24, all indicating a rotation in a clockwise (or counterclockwise) direction around Mount Diablo, the lengths of the arrows being proportional to their distances from Mocho and Mount Diablo. The fact that the computed apparent displacements of 1906, as shown by the red arrows on maps 24 and 25, do not show any such systematic relation to each other, indicates that the line Mocho-Mount Diablo remained unchanged in azimuth on April 18, 1906.

<sup>1</sup> The probable error of observed azimuth in 1887 was  $\pm 0.21''$  and in 1907  $\pm 0.20''$ . The expression "probable error" is here used in the technical sense in which it is used in connection with the least square method of computation.

<sup>2</sup> The discrepancy of about 4" on each date between the azimuth determined by astronomic observations and the azimuth determined by triangulation is what is known as "station error" in azimuth and is due to the deflection of the vertical at the observation station. It does not enter into the present discussion, which is based on differences of azimuths of the same kind, either astronomic or geodetic, on different dates at the same station.

Similarly, if either Mocho or Mount Diablo had moved on April 18, 1906, in such a direction as to increase (or decrease) the distance between them, the effect upon the computations of apparent displacements would have been to produce a set of red arrows on maps 24 and 25, all pointing toward (or from) Mocho and Mount Diablo, the lengths of the arrows being proportional to their distances from Mocho and Mount Diablo. No such systematic relation appears among the arrows.

Another item of evidence is still available which indicates that the absolute displacement of points far to the eastward of the fault was zero on April 18, 1906. From 1899 to date a series of observations of latitude by observations upon the stars has been in progress continuously for the International Geodetic Association at Ukiah, California. The purpose of these observations is to detect variations in latitude due to any cause. The observations are of an extremely high grade of accuracy and they are made on every clear night. Dr. S. D. Townley, in charge of these observations, made a special study of the 233 observations made during the interval April 4-May 4 inclusive, 1906, to determine whether any sudden change of latitude took place on April 18.<sup>1</sup> He found no such change. The observations are competent to determine with reasonable certainty any change as great as 0.03", corresponding to 1 meter (3 feet). It is therefore reasonably certain that the southward component of the motion, if any, of the pier on which Dr. Townley's latitude instrument was mounted at Ukiah, was less than one meter on April 18, 1906. Ukiah is about 42 kilometers (26 miles) from the fault and to the eastward of it. Mocho and Mount Diablo are much farther from the fault (53 kilometers). It is important to note that latitude observations determined the absolute displacement rather than the relative displacement and that they are independent of observations at any other station.

For the reasons set forth above, it is believed to be certain that the permanent displacement, if any, of either Mocho or Mount Diablo on April 18, 1906, must have been extremely small.

During verbal discussions of the earthquake of April 18, 1906, it has been suggested more than once that one of its possible effects may have been to change the position of the earth with relation to its axis of rotation and so produce a change of latitudes. If an appreciable effect of this kind were possible, the validity of the above reasoning in regard to the latitude observations at Ukiah would be questionable. Accordingly, a computation of this possible effect has been made.<sup>2</sup> It was found that if it be assumed that the mass displaced in a northerly direction to the westward of the fault comprized 40,000 square kilometers (15,600 square miles) of the earth's crust, having a mean latitude of 38° and thickness or depth of 110 kilometers (68 miles), that this material had an average density of 4.0 and that the northerly component of the displacement was 3 meters (10 feet), the position of the pole of maximum moment of inertia would be displaced by 0.0007", corresponding to 0.002 meter (0.006 foot). This is a limiting value certainly much larger than the actual value, for all assumptions entering the computation as to the area, depth, density, amount of displacement, and mean latitude have been made such as to make the computed value certainly too great. Moreover, the similar displacements of contrary direction to the eastward of the fault would partially cancel those on the westward side which have been considered. When the pole of maximum moment of inertia is displaced, the pole of rotation is not immediately changed with reference to the earth. The pole of rotation tends always to seek the pole of maximum moment of inertia and travels around it in an irregular path. It is the instantaneous position of the pole of rotation with reference to the earth which fixes the latitude at any instant. Hence

<sup>1</sup> W. S. P. Atgatiimii \*\* Published in the Publications of the Astronomic Society of the Pacific Vol. 4, No. 10, 1910, under the title The Latitude of the Ukiah Observatory before and after

<sup>2</sup> and method of computation is shown in *Traité de Mécanique Céleste*, par F. Tisserand, thier-Villars, Tome II, pp. 485-487.

even this extremely small displacement of the pole of maximum moment of inertia computed above, 0.002 meter, does not immediately affect the latitude of points in California, but only tends to change them by that average amount in the course of a year or more. The effect of the earthquake on the latitudes of points outside the region of actual displacement of the surface is therefore entirely negligible. The earthquake changed the latitude of marked points on the earth's surface within the disturbed region by the amount of the northward or southward components of the displacement of the points.

Similarly, the possible effect of the displacements on the deflections of the vertical, that is, upon the direction of gravity at any point, is too small to be considered.

The displacements near Point Arena were computed upon the assumption that the triangulation stations Fisher and Cold Spring remained unmoved during the earthquake of 1906. Is this assumption true? The station farthest to the eastward from the fault at which a displacement in 1906 has been detected with certainty is Mount Tamalpais, distant 6.4 kilometers and displaced 0.53 meter. Also the rate of decrease of displacements at this distance has been found to be 0.13 meter per kilometer of increase of distance from the fault. At this rate, the displacement would become zero at about 11 kilometers from the fault. Fisher is 11.2 and Cold Spring 13.5 kilometers from the fault; hence it is reasonably certain that if the displacement was not zero, at these two stations, it was so nearly zero that it could not have been detected with certainty.

A high degree of accuracy has been claimed for the triangulation. There is abundant evidence available from which to determine the actual accuracy, as has been indicated in an earlier part of this report. A large amount of time has been spent in studying this evidence in order to insure that the estimates of the accuracy of the determination of the various apparent displacements might be reliable. The methods necessarily followed in estimating the accuracy are too technical and too complicated to be included in this report. Two illustrations of the degree of accuracy attained in the observations may prove interesting, however.

The position of the Lick Observatory small dome was determined after the earthquake of 1906 by intersections upon it from four stations, Loma Prieta, Sierra Morena, Red Hill, and Mocho. There were discrepancies among these observations which were adjusted by the method of least squares and a resulting most probable position adopted and used in computing the apparent displacement given in table 1. The mean observation from Loma Prieta hit 0.38 meter (1.2 feet) to the left of the position adopted for the dome. The mean observation from Sierra Morena hit 0.22 meter (0.7 foot) to the right, that from Red Hill 0.01 meter (0.03 foot) to the left, and that from Mocho 0.11 meter (0.4 foot) to the left of the adopted position. The words "right" and "left" refer in each case to the Lick Observatory dome as seen from the station named. The distance of the four observation points from the Lick Observatory were, Loma Prieta 31 kilometers (19 miles), Sierra Morena 59 kilometers (37 miles), Red Hill 46 kilometers (29 miles), and Mocho 17 kilometers (11 miles).

Similarly the determination of the position of the Lick Observatory before the earthquake depended upon observations taken from seven stations, Santa Ana, Mount Toro, Loma Prieta, Sierra Morena, Mount Tamalpais, Mount Diablo, and Mocho. The line from Mount Tamalpais, 106 kilometers (66 miles) long, mist the adopted position by 0.36 meter (1.2 feet). The other six all came nearer than this to the adopted position.

The Farallon Light-house was determined between 1868 and 1906 by intersections upon it from three stations, Mount Helena, Mount Tamalpais, and Sierra Morena. The mean observation from Mount Helena, distant 112 kilometers (70 miles), mist the adopted position by 0.30 meter (1.0 foot) and the other two lines came closer. In 1906-1907 the Farallon Light-house was determined by intersections upon it from the six stations Ross Mountain, Tornaes Bay, Point Reyes Hill, Sonoma, Mount Tamalpais, and Sierra Mo-



rena. The line from Sonoma, 79 kilometers (49 miles) long, mist the adopted position by 0.10 meter (0.3 foot) and all the others came closer.

One other assumption remains to be examined. The displacements of 1868 were computed on the assumption that the line Mount Tamalpais to Mount Diablo had a certain length and azimuth before 1868 and a certain different length and azimuth after 1868; Mount Tamalpais being supposed to be in a new position, but Mount Diablo unmoved. The two positions for Mount Tamalpais *were* derived from certain computations based in turn on assumptions that certain other stations remained unmoved in 1868, or practically so.

The azimuth of the line Mount Tamalpais to Mount Diablo was determined by observations upon stars in 1859, and again in 1882; the later observations made the azimuth 7.84" greater than earlier observations. The two adopted azimuths from the computations of triangulation referred to above also differ by 5.38\*, the later adopted value being the greater.

The fact that the two independent determinations of change of azimuth, one astronomical and one geodetic, agree within 2.46" is a strong proof that the adopted geodetic azimuths are correct, 2.46" being within the possible range of the various observations.

Following the same reasoning as for Mocho and Mount Diablo, the computed displacements of 1868, as shown by red arrows on maps 24 and 25, indicate that the two azimuths and two lengths used for the line Mount Tamalpais to Mount Diablo, before and after 1868, must be very close to the truth.

#### CHANGES IN ELEVATION.

The preceding portions of this Report have dealt with permanent horizontal displacements caused by the earthquake of 1906. It is important to know whether permanent displacements in the vertical sense also occurred. Upon this point the observations of the Coast and Geodetic Survey furnish evidence for a small area, involving parts of San Francisco, both sides of the Golden Gate, and Sausalito, 1.25 miles north of the Golden Gate.

At the time of the earthquake an automatic tide-gage was in operation at the Presidio Wharf, in San Francisco, on the southern side and about 1.25 miles to the east of the narrowest part of the channel thru the Golden Gate. The gage had been in operation at that point continuously since July 17, 1897, and is still in operation.

The record made by this gage on April 18, 1906, showed an oscillation, with a range of about six inches, in the water surface evidently produced by the earthquake, but it showed no evidence of a change in the relation of the gage zero to mean sea-level. In other words, the record for that day does not indicate that the tide-staff had been changed in elevation by the earthquake.

To detect any possible small change in elevation it is, of course, necessary to examine much more record than that for a single day. The examination has now been extended by computation to include a whole year of observations since the earthquake for comparison with nine years of observations before it.

The following table shows the reading of mean sea-level on the fixed tide-staff for each of ten years, as determined by taking the mean of the hourly ordinates of the tidal curve. The annual means are taken rather than means for any other period in order to eliminate annual inequalities, presumably due to meteorological causes, which affect the means for separate months. May 1 is taken as the beginning of the complete year available after the earthquake. Since it is not convenient, in the computation, to separate any month's observation into two parts, the year is commenced on May 1, rather than on April *IK* the date of the earthquake. The first year, 1897-1898, is incomplete because the observations were not commenced until July 17, 1897.

Table 4. — Readings of Mean Sea-level on the Fixt Tide-staff.

PERIOD	READING OF MEAN SEA- LEVEL ON TIDE-STAFF	MEANS
	<i>Feet</i>	
July 17, 1897 to Apr. 30, 1898 . . . . .	8.339	8.318
May 1, 1898 to Apr. 30, 1899 . . . . .	8.298	
May 1, 1899 to Apr. 30, 1900 . . . . .	8.528	
May 1, 1900 to Apr. 30, 1901 . . . . .	8.550	8.520
May 1, 1901 to Apr. 30, 1902 . . . . .	8.430	
May 1, 1902 to Apr. 30, 1903 . . . . .	8.584	
May 1, 1903 to Apr. 30, 1904 . . . . .	8.509	8.652
May 1, 1904 to Apr. 30, 1905 . . . . .	8.667	
May 1, 1905 to Apr. 30, 1906 . . . . .	8.659	
May 1, 1906 to Apr. 30, 1907 . . . . .	8.631	

The ten annual means show an unmistakable tendency to fall into three groups, as indicated by the means shown in the last column of the table. Within each group there is no apparent tendency to increase or decrease. Between the first and second groups the reading of mean sea-level increased 0.202 foot and between the second and third groups, it again increased 0.132 foot. Such an increase corresponds to a subsidence of the zero of the tide-staff with reference to mean sea-level. An examination of the monthly means indicates that probably the subsidence occurred suddenly in each case, the movements taking place about June, 1899, and April, 1904. The record must not be considered as proving positively that these two subsidences took place. The changes are not clearly beyond the range of possible error in the determination of mean sea-level on account of irregular changes in the water surface due to causes not clearly understood, tho they are beyond the possible range of instrumental errors.

The annual mean for the one year after the earthquake, 1906-1907, agrees with the two preceding annual means within less than 0.04 foot. In no other case in the table do three successive annual means agree so closely with each other as these three. Apparently, therefore, no change in the elevation of the zero of the tide-staff occurred at the time of the earthquake.

As further evidence that no appreciable change in the elevation of the tide-staff took place on April 18, 1906, the following table is submitted. Corresponding months of two years, one before and one after the earthquake, are compared to avoid the effects of annual inequalities. The comparison indicates that no change took place in April, 1906.

Table 5. — Monthly Mean Readings of Mean Sea-level on Tide-staff.

	1905-1906	1906-1907	DIFFERENCE
	<i>Feet</i>	<i>Feet</i>	
May . . . . .	8.507	8.462	+ .045
June . . . . .	8.416	8.506	- .090
July . . . . .	8.668	8.688	- .020
August . . . . .	8.676	8.797	- .121
September . . . . .	8.648	8.632	+ .016
October . . . . .	8.690	8.442	+ .248
November . . . . .	8.751	8.295	+ .456
December . . . . .	8.479	8.625	- .146
January . . . . .	8.701	8.784	- .083
February . . . . .	8.877	8.725	+ .152
March . . . . .	8.934	8.944	- .010
April . . . . .	8.558	8.669	- .111
		Mean—	+ .028

The zero of the tide-staff was connected by leveling with the group of bench-marks near the gage at various times during the interval 1898-1907, including a determination after the earthquake. The leveling showed no appreciable change in the relation in elevation of the bench-marks and the tide-staff. Hence, the preceding statements in regard to a possible subsidence of the tide-staff on two occasions and in regard to its constancy of elevation on April 18, 1906, also apply to this group of bench-marks.

Before the earthquake the Coast and Geodetic Survey had done leveling which connected the gage at the Presidio Wharf with various bench-marks in San Francisco from Fort Point to the Union Iron Works, and with bench-marks at Sausalito. This leveling was not of the grade of accuracy known as precise leveling nor was it done continuously. There are also available for use in the present investigation certain relative elevations of bench-marks before the earthquake furnished to the Coast and Geodetic Survey by the city engineer of San Francisco. These include a bench-mark near the gage at the Presidio Wharf.

After the earthquake Mr. B. A. Baird, Assistant, Coast and Geodetic Survey, ran a line of precise levels from the Presidio gage to Fort Point and Sausalito, and to the eastward thru San Francisco, to the Union Iron Works, connecting with various old bench-marks.

There were 26 bench-marks connected by the leveling before the earthquake which were recovered with certainty by Mr. Baird and the elevations redetermined by him. The following table shows the elevations of these bench-marks before and after the earthquake and their apparent changes in elevations. All of the elevations in the table are referred to the same datum, which is the reading 8.514 feet (2.5951 meters) on the fixed tide-staff at the Presidio Wharf, that being approximately mean sea-level. All the elevations are computed on the supposition that the zero of the tide-staff at the Presidio Wharf remained unchanged at the time of the earthquake.

The table shows no appreciable change of elevation of the bench-marks at the Presidio Wharf. The maximum apparent change in elevation is 7.0 mm. (0.3 inch), a quantity within the possible range of error of the leveling. Mr. G. K. Gilbert, Geologist of the U. S. Geological Survey, at the close of an examination made soon after the earthquake and before the leveling had been done, expressed the opinion that if this group of bench-marks had not changed their relative elevations, they probably had not changed in relation to the tide-staff. It is probable, therefore, that these two bench-marks and the tide-staff maintained their absolute elevations unchanged.

At Fort Point, the three bench-marks near the shore show an apparent rise of 74 mm. (2.9 inches) on an average, and bench-mark 9, high up on Fort Point, shows a slightly smaller apparent rise, 59 millimeters (2.3 inches). All these are on ground supposed to be stable. The rise indicated by the city leveling, in the last column, is considerably smaller.

The two bench-marks at Sausalito show an apparent rise of 37 millimeters (1.5 inches). It is not certain that this represents a real change in elevation as referred to the zero of the Presidio tide-staff. The errors of the old and new leveling, including the crossing of the Golden Gate (about 1.25 miles) in each case, may account for the apparent change. In the leveling before the earthquake the elevation was transferred from Presidio to Sausalito by water-levels and also by wye leveling with a difference of 13 millimeters (0.5 inch). In the precise leveling after the earthquake, the two independent crossings of the Golden Gate, each depending on many hours of observation, differed by 30 millimeters (1.2 inches).

The three bench-marks at and near Fort Point showed small apparent changes in elevation.

From an examination made soon after the earthquake Mr. G. K. Gilbert, Geologist, expressed the opinion that the bench-marks at Lafayette Park were probably more stable

Table 6. — Elevations of bench-marks before and after the earthquake.

LOCALITY	CHARACTER OF BENCH-MARK	B.M.	ELEVATIONS			NEW-OLD (Coast and Geodetic Survey)	NEW-OLD (CITY)
			After Earthquake Coast and Geodetic Survey 1906-1907	BEFORE EARTHQUAKE			
				Coast and Geodetic Survey 1877-1905	City Levels 1901-1906		
			<i>Meters</i>	<i>Meters</i>	<i>Meters</i>	<i>Mm.</i>	<i>Mm.</i>
Presidio Wharf. ....	Zero of tide-gage	11	- 2.5951	-2.5951	.....	0.0	.....
	Hinge socket of door of brick warehouse.	12	3.8932	3.9002	3.9002	- 7.0	- 7.0
	Copper bolt in granite post.	15	2.7426	2.7371	.....	+ 5.5	.....
Fort Point .....	Copper bolt in natural rock.	4	6.7585	6.6797	.....	+ 78.8	.....
	Copper bolt in granite post.	5	14.7958	14.7237	.....	+ 72.1	.....
	Copper bolt in granite sea-wall.	6	3.9275	3.8554	3.8895	+ 72.1	+ 38.0
	Brass plate on con- crete emplacement.	9	60.7745	60.7151	60.7232	+ 59.4	+ 51.3
Sausalito. ....	Copper bolt in rock ...	2	1.3909	1.3564	.....	+ 34.5	.....
	Granite post .....	3	11.6073	11.5672	.....	+ 40.1	.....
Van Ness and Lom- bard Aves.	Star on iron plate in street.	27B	29.4047	.....	29.3967	.....	+ 8.0
Fort Mason .....	Granite post .....	28	32.5727	32.5606	32.5493	+ 12.1	+ 23.4
Fort Mason .....	Granite post .....	29	31.0876	31.0854	31.0649	+ 2.2	+ 22.7
Lafayette Park. ....	Granite post .....	24A	101.7846	.....	101.7412	.....	+ 43.4
	Pendulum pier. ....	25	113.9662	114.0414	.....	- 75.2	.....
	Transit pier. ....	27	115.3477	115.4222	.....	- 74.5	.....
Union Iron Works ...	Brass spike in brick bldg.	50	3.7860	3.8384	.....	- 52.4	.....
	Window shutter socket	47	4.4482	4.4004	4.4299	+ 47.8	+ 18.3
	Bolt in wall of bldg	48	6.2121	6.1695	.....	+ 42.6	.....
19th and Bryant Sts...	Copper bolt in brick bldg.	58	13.6176	13.5889	13.5883	+ 28.7	+ 29.3
Magdalen Asylum, Po- trero Ave.	Copper bolt in brick bldg.	61	23.3281	23.3063	23.2977	+ 21.8	+ 30.4
Appraisers' Bldg. .... Potrero Ave. and Divi- sion St.	Iron Rod .....	40B	3.3068	.....	3.3241	.....	- 17.3
	Fire hydrant .....	441	5.9000	.....	5.9695	.....	- 69.5
17th and Carolina Sts. Mariposa St. between Penn. and Iowa Sts.	Nail in doorstep. ....	City	6.0238	.....	5.9978	.....	+ 26.0
	Bolt in concrete on bridge over S. P. tracks.	S. P.	10.4666	.....	10.4110	.....	+ 55.6
Cal. and Montgomery Sts.	Water table of Parrott Bldg.	41	5.1488	5.0173	.....	+ 131.5	.....
East and Mission Sts.	Iron pillar of brick bldg.	43	2.4828	2.8523	.....	- 369.5	.....
Folsom between Main and Beale Sts.	Granite post set in brick wall.	44	5.4835	5.5516	.....	- 68.1	.....

than any of the others examined by him. The table indicates that the two of these bench marks, formerly determined by the Coast and Geodetic Survey leveling, subsided 75 millimeters (3.0 inches) and that the one, determined by the city leveling, rose 43 millimeters (1.7 inches). There is no apparent reason for the contradiction among the three bench-marks of this group.

For the three bench-marks at the Union Iron Works, the table shows a contradiction, two of them having, apparently, increased in elevation and one having decreased. The greatest change is, however, only 52 mm. (2.0 inches). The Union Iron Works is said to be partly on filled ground.

The two bench-marks near the Magdalen Asylum apparently increased in elevation as shown by both the Coast and Geodetic Survey and city leveling.

Of these bench-marks, the thirteen in the five groups at Fort Point, Sausalito, Fort Mason, Union Iron Works, and Magdalen Asylum, showed an average apparent rise at the time of the earthquake of 35 millimeters (1.4 inches) as determined by the Coast and Geodetic Survey leveling. As the leveling simply gives relative elevations the question arises, Does this quantity represent an average rise of the thirteen bench-marks or does it represent a settlement of the zero of the tide-gage and the adjacent bench-marks at the Presidio Wharf? The tidal observations are not competent to determine this question with certainty. The general experience with determinations of mean sea-level, from long series of tidal observations, warrants the statement that the error in determination from a single year is as apt to be greater as less than 0.75 inch (19 millimeters) and that it may sometimes be as great as 2.5 inches (64 millimeters). It is possible, therefore, that the two bench-marks at the Presidio Wharf and the zero of the tide-gage have settled 35 millimeters or that it is, in part, a subsidence at the Presidio and in part a rise at the other places.

The elevations of the group of four bench-marks in the table commencing with 40B at the Appraisers<sup>3</sup> Building, were determined before the earthquake by the city engineer, but not by Coast and Geodetic Survey leveling. These four, in various parts of the city, show no apparent change in elevation greater than 69 millimeters (2.7 inches). Two of them apparently rose and two subsided.

The apparent changes in elevation of the three bench-marks in the table, commencing with 41 at California and Montgomery Streets, are not supposed to have much significance in connection with the question of whether a general change of elevation took place. These three bench-marks were each subject to local disturbances during the earthquake or were near or on filled ground.

In ten cases the old leveling determined elevations of hydrants and the new leveling determined elevations on hydrants in the same locations but known, from the descriptions, to be different from the old hydrants. Similarly, in seven other cases, the old leveling established the elevations of points on curbstones, steps, or doors, and in each of these cases in the new leveling it was found to be impossible to recover the old point accurately. In all of these 17 cases there is, therefore, only an approximate connection between the old and the new leveling. The evidence from these bench-marks has all been examined carefully and does not lead to any different conclusion from that which may be drawn from the table above.

The general conclusion from both the leveling and the tidal observations is that, within the region examined, there occurred no general change of elevation of sufficient magnitude to be detected with certainty.

It is an opportune time, at present, on account of local changes in elevation at various bench-marks, to adopt the best possible determination of mean sea-level which is available up to date and to refer all new elevations determined since the earthquake to that datum. Accordingly, the reading 8.652 feet (2.7371 meters) on the tide-staff at the Pro-

sidio, given in column 5 on page 143 which is the mean for the three complete years, May 1, 1904, to April 30, 1907, is adopted as being mean sea-level. The values given in column 4 of the table on page 143 are referred to the reading 8.514 feet (2.5951 meters) as mean sea-level. Hence, a correction of  $-0.138$  foot ( $-0.0420$  meter) should be applied to these values to obtain the elevations now adopted as best.

It is uncertain, as already indicated in this report, whether this correction of  $-0.0420$  meter is due to improvement in the determination of the relation of mean sea-level to the tide-staff or to a subsidence of the tide-staff and adjacent bench-marks in 1904 or earlier, or to both.

## NOTE ON THE COMPARISON OF THE FAULTS IN THE THREE EARTHQUAKES OF MINO-OWARI, FORMOSA, AND CALIFORNIA.

BY F. OMORI.

The three great earthquakes of Mino-Owari (Central Japan) on October 28, 1891, of Kagi (Formosa) on March 17, 1906, and of California on April 18, 1906, were each accompanied by the formation of remarkable geological faults, whose total lengths were about 100, 50, and 430 kilometers respectively. The dislocation in the California earthquake was formed partly along, and partly off, the coast of California, belonging to the category of longitudinal faults.

The dislocation in the Mino-Owari and Kagi earthquakes were, on the other hand, formed nearly at right angles to the course of the Main Island (Nippon) and the axis of Formosa Island respectively, both belonging to the category of transverse faults.

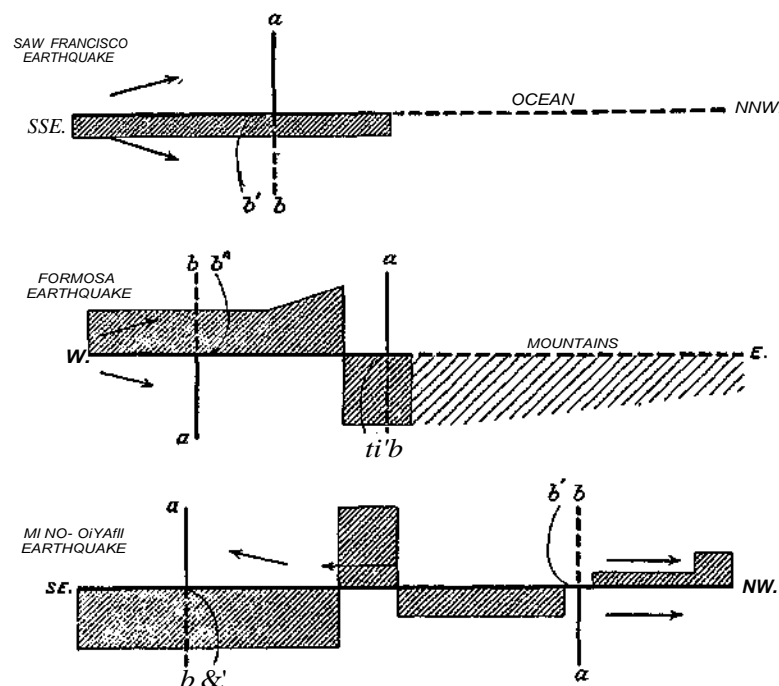

FIG. 43 a. — Full line is fault (ascertained). Shaded part is depressed region. Dotted line is probable continuation of fault. Lightly shaded part represents probable depression. Arrow indicates the direction of maximum (vibratory) motion.

Notwithstanding these differences, there are certain similarities among the three cases. Thus, in each of the three earthquakes, the direction of motion at different places in the immediate neighborhood of the fault was not perpendicular, but more nearly parallel, to the strike of the latter. This seems to indicate that the formation of the faults was mainly due, in each case, not to such actions as a simple falling down or sudden creation of a cavity underground, but to the existence of shearing stresses in the plane of fracture possibly of two opposing forces acting either from the center toward both ends of the fault-line, or toward the center from both ends.

The accompanying figure is a diagrammatic illustration of the three faults, the line  $ab$  indicating, in each case, a straight line (say, road) which suffered a shearing movement in such a way that the part  $b$  on the depressed side was displaced to the new position  $b'$ , and generally transformed into a curve.

From the figure it will be seen that there existed in each fault what may be called the *central point*, where the disturbance of the ground is greatest and about which the shear and depression along the line of dislocation is more or less symmetrical. In the case of the Mino-Owari earthquake the central point was in the vicinity of the village of Midori in the Néo-Valley, where a very remarkable depression of the ground took place. The corresponding point on the Formosa fault was between the villages of Bishō and Kaigenkō. In the California earthquake the northern half of the fault was in part under the ocean, but the central point was probably in the vicinity of the Tomales Bay, the greatest amount of disturbance having occurred there.

The greatest vertical dislocation of 18 feet occurred in the Mino-Owari earthquake, while the greatest horizontal shear occurred in the California earthquake. In the latter the vertical displacement was only 1 or 2 feet, while in the former there was also a large horizontal shear of about 18 feet. In the Formosa earthquake, whose magnitude was much smaller than the other two, the vertical and horizontal displacements of the ground were each of a moderate scale, the maximum amounts being 6 and 8 feet respectively. The maximum (vibratory) motion in the Mino-Owari earthquake showed a tendency of being directed from the central point toward each end; while, in each of the two other earthquakes, the same motion was, as far as can be ascertained, directed from one end toward the center. Again, the direction of the maximum (vibratory) motion was, in the Formosa earthquake, the same as that of the shear of the depressed ground. In the two other earthquakes, however, the reverse was the case. These differences are probably due to the variation in the manner of the action of the force along the fault-plane which finally produced the dislocations.

---

#### REVIEW OF SALIENT FEATURES.

The differential displacement of the earth's crust effected by the movement on the San Andreas fault on April 18, 1906, may for convenience be resolved into two components, the horizontal and the vertical. Of these the horizontal movement was the more important and was susceptible of measurement, giving minimum values for the amount of displacement in this direction practically all along the trace of the fault, except at the extreme north and extreme south. The vertical movement was small compared with the horizontal, and was established satisfactorily only in the region to the north of the Golden Gate.

Two kinds of evidence of vertical displacement were available. The first of these was the formation of scarps along the fault-trace, and the second was the change on portions of the coast of the level of the land relatively to sea-level. The scarps that appeared as features of the fault-trace were in part fresh facets where none had existed before the earthquake and in part accentuations or additions to old scarps due to former movements. In both cases exact measurements were rendered difficult by the drag of the soil along the rupture, and by the complication due to the larger horizontal movement. But making all allowances for the masking effect of drag of the soil, it is certain that the height of these scarps, or of the additions to old ones, was quite variable, even in the same general locality, within a range of a few inches up to about 3 feet. It is suggested that this variation is referable in considerable measure to the drag and adjustment of materials in the zone beneath the soil; so that the true displacement of the firm rocks lies between, the extremes observed.

The evidence of vertical displacement, based on the recognition of scarps, indicates a slight upward movement of the crustal block on the southwest side of the fault in the northern territory. South of the Golden Gate there is no very satisfactory or consistent



evidence of differential vertical movement. For many segments of the fault-trace in this region, there is no suggestion of displacement of this kind. In other portions, notably in the vicinity of Black Mountain and southward, the movement appears to have been distributed over a considerable zone, with the formation of many auxiliary cracks. Upon the latter scarps were formed, but these in some cases faced the northeast and in others the southwest, and the resultant effect is not known. Judging from the localities where the movement was not so distributed, but was confined to a narrow zone, the differential vertical displacement was nil.

Similarly, the evidence of vertical displacement, based on a comparison of the relative position of land and sea-levels before and after the earthquake, is limited to the region north of the Golden Gate. The Point Reyes Peninsula appears, from this class of evidence, to have been probably upraised slightly by the fault movement; but the evidence is not entirely conclusive.

Observations conducted by the Coast and Geodetic Survey thruout the year succeeding the earthquake, at the tide-gage station near Fort Point in the Golden Gate, show that the relative level of land and sea at that point is the same as it was before the earthquake. Since this station lies on the northeast side of the fault, the observation would appear to indicate that any upward movement of the crustal block on the southwest side was an absolute one.

The horizontal displacement on the fault, as measured on fences, roads, and various structures which cross the fault-trace, is also apparently quite variable, ranging from a foot or less up to 20 or 21 feet. This variation is probably due to a number of causes. The principal one of these is the fact that the displacement was not always confined to the sharp line upon which an offset was observed at any locality. Auxiliary cracks, distributed over a zone not uncommonly a few hundred feet wide, took up portions of the displacement; and these auxiliary cracks doubtless escaped observation in many cases. Indeed, owing to the yielding character of the superficial mantle of soil and regolith, it is probable that many of these auxiliary cracks did not appear as ruptures at the surface. Besides this distribution of the displacement on auxiliary cracks satellitic to the main rupture, the deformation of the ground along the latter, both superficially and in its deeper portions, was probably variable. The extent of this drag is shown in a few instances that have been susceptible of measurement; notably the fence at Fort Ross, surveyed by Mr. E. S. Larsen, on which a displacement of 12 feet was distributed over a distance of 415 feet on the southwest side of the fault-trace; the roadway near Point Reyes Station, where a displacement of 20 or 21 feet was distributed over 60 feet; the fence south of Mussel Rock, surveyed by Mr. H. O. Wood, in which a displacement of 13 feet was distributed over 250 feet on the southwest side of the fault-trace and 40 feet on the northeast side; the 3 fences surveyed by Mr. R. B. Symington near San Andreas Lake, one showing a displacement of 10.9 feet, distributed over more than 1,100 feet, the second a displacement of 10.4 feet distributed over more than 300 feet, and the third a displacement of 12.7 feet distributed over more than 2,200 feet; and the tunnel at Wright, surveyed by the engineers of the Southern Pacific Company, showing a displacement of 5 feet distributed over nearly a mile on the southwest side of the fault-trace. These instances are doubtless indicative of the general character of the deformation of the ground in the immediate vicinity of the fault, and aid in understanding the variable expression of the amount of offset at the main fault-trace. The recognition of the distribution of the movement on auxiliary cracks, some of which may not have appeared at the surface, and the deformation of the ground along the zone of rupture, justifies the conclusion that, except under peculiar conditions — such, for example, as in the marsh at the head of Tomah's Bay — the maximum figures obtained for the displacement by the measurement of offsets at the surface must be a minimum expression for the true extent of the

movement in the firm rocks below. For the middle half of the extent of the fault-trace from Point Arena to Crystal Springs Lake, these maximal measurements are very commonly from 15 to 16 feet, and these figures may thus be taken as a minimum expression for the amount of the displacement on the fault for this segment. In the southern quarter of the extent of the fault-trace, the maximum offset is about 8 feet, and this may similarly be taken as a general minimum expression for the displacement on this segment, except for the extreme south end, where it dies out. The amount of displacement at the northern end of the fault has not been ascertained.

The geodetic measurements of the earth movement, as presented in the paper by Messrs. Hayford and Baldwin, are of extreme interest and form one of the most important contributions to the study of the earthquake. The evidence of displacement observed along the fault-trace affords measurements of the total relative movement only, while the geodetic work gives us an approximate measure of the absolute movement on either side of the fault, and the distribution of the movement away from the fault. The results of this geodetic work are not only set forth in detail by the paper of Messrs. Hayford and Baldwin, but they are also admirably summarized, so that all that seems necessary in this place is to discuss very briefly these results from a geological point of view.

A notable feature of the paper is the discovery of a movement of the earth's crust which antedates the earthquake of April 18, 1906, and which is referred to the earthquake of 1868; altho it is recognized that the date and duration of the movement cannot, on the data available, be positively determined. Inasmuch as the time of this movement is left an open question, and is referred to the year 1868 largely as a matter of convenience in discussion, it may be of advantage to inquire briefly whether or not it may have some other significance than that of a sudden movement occurring in that year.

Altho, as shown in another part of this report, the earthquake of 1868 was related to a rupture or series of ruptures of the ground at the base of the hills on the northeast side of San Francisco Bay, there was no evidence of a large relative displacement such as occurred in 1906. It seems reasonable to suppose that if the earlier movement in question had occurred suddenly in the same way as that of April 18, 1906, we should have had a similar manifestation of faulting within the region affected. Since there was no such manifestation the reference of the earlier movement to the earthquake of 1868 may be fairly questioned, and another hypothesis entertained to explain it, particularly if this hypothesis harmonizes in some considerable measure with the results of the geodetic survey.

This hypothesis is that the earlier movement is not immediately or exclusively associated with the earthquake of 1868, but is the expression of the strain in the earth's crust which led to the rupture or slip of 1906 and the consequent earthquake. That rupture presupposes a condition of strain, and it is difficult if not impossible to conceive of such a sudden disruption except as a relief from strain. Such strain involves the idea of slow displacement; and if a series of points had been established in the territory affected at different dates, with reference to some base beyond it, a measure of this slow displacement or creep of the earth's crust might have been obtained.

The strain culminated in a slip on an old rupture plane and may fairly be supposed to have been more or less symmetrically distributed with reference to that plane, so that; when relief was effected by slip, the movement involved would be equal in amount on the two sides of the fault.

This hypothesis and its implications appear to fit fairly well with the results of the geodetic resurvey, particularly for that portion of the territory where the earlier movement can be most satisfactorily discriminated from the displacement of 1906. For example in the Tomales Bay region there are ten points, viz.: Bodega Head, Tomales Point, Tomales Bay, Foster, and Point Reyes Hill on the west side of the fault of 1900, and Bodega, Smith, Mershon, Hans, and Hammond on the east, at which the two move-

ments are separated. These stations are found to have moved in a nearly north direction an average amount of 1.56 meters in the interval between "before 1868" (1856-1860) and "after 1868" (1874-1891). Since the values upon which this average is based were arrived at in part by methods of interpolation, there is no great variation from the average at any of the ten stations. The interval within which this northerly movement took place is rather indeterminate, but may be placed doubtfully at 32 years.

Under the hypothesis here presented this movement continued at a probably uniform rate for the next 16 years up to the time of the earthquake of 1906. This would give us a total northerly movement for the interval from 1856-1860 to 1906 of 2.34 meters. Now the northerly component of the combined earlier and 1906 movements, shown in table 3 of Hayford and Baldwin's paper, is on an average 4.95 meters for the five stations west of the fault-line. This includes the sudden movement of 1906 plus the slow creep of 2.34 meters above deduced. The value for the northerly component of the sudden movement of those points in 1906 is thus  $4.95 - 2.34$ , or 2.61 meters. Similarly the southerly component of the combined movements for the five stations to the east of the fault is found to be on the average 0.09 meters. The southerly component of the sudden movement of 1906 was therefore  $0.09 + 2.34$ , or 2.43 meters. The absolute movement on the two sides of the fault on April 18, 1906, was thus nearly the same in amount.

The reference of the earlier movement to a slow creep thus appears to harmonize with and therefore tends to confirm the *a priori* assumption that the absolute movement of 1906 should have been the same on both sides of the fault. Were data available as to the time at which other groups of stations were determined in position, it is probable that a similar result would be reached. We may consider, therefore, that the earlier movement is better explained on the hypothesis of slow creep, continuing up to April 18, 1906, than on the assumption that it occurred at or about the time of the earthquake of 1868. This conclusion applies to the region north of San Francisco Bay. To the south of the Bay the data available are inadequate for a satisfactory separation of the two movements, except in the case of Loma Prieta, and here the earlier movement appears to have been southerly.

Another result of the geodetic resurvey which points to a slow creep of the region under strain precedent to April 18, 1906, is the distribution of the displacement on that date. The measurements of the absolute displacement on the two sides of the fault show that it was notably greater near the fault than at points remote from it. Thus if we imagine a series of points in a straight line transverse to the fault before the earthquake that line was so deformed that the segment to the west of the fault curved northerly and the segment to the east curved southerly in approaching the fault-trace. This deformation can be most readily explained by supposing that the series of points upon the assumed straight line were determined as to position in the first instance upon the surface of a portion of the earth under elastic strain, so that when relief was effected by rupture, the points tended to assume positions relative to one another which they would have had if they had been determined before the advent of the strain.

It may be further pointed out that the conclusion reached by Hayford and Baldwin to the effect that the absolute movement on the west side of the fault was on the average twice as great as the movement on the east side is founded on the assumption of the stability of the base-line Diablo-Mocho. In view of the unknown extent of the earth movement of April 18, 1906, it would seem preferable to make the assumption that the relief from strain was approximately distributed equally on the two sides of the fault and from this infer the amount of the southeasterly displacement of Diablo and Mocho. The assumption that Diablo and Mocho were not affected by the disturbance of April 18, 1906, is based on the following considerations:

1. There was no change in the azimuth of the Diablo-Mocho line.
2. There was no change in the length of that line.
3. There was no appreciable change in the relations of these two stations to certain others nearer the fault.
4. The latitude of Ukiah remains the same as before the earthquake.

The first three of these conditions would be fulfilled if the region including all the stations occupied had moved in unison southeasterly with but little or no rotation, a possibility which it is difficult to deny. The fourth consideration does not preclude this possibility since the amount of movement involved is probably less than the errors of the method used for the determination of the latitude of Ukiah.

In the region about Monterey Bay the most interesting fact brought out by the geodetic resurvey is that the combined effect of the earlier movement and that of 1906 is a southerly migration of the earth's crust on both sides of the San Andreas rift. It is probable from direct observations of relative displacement along the fault-trace in 1906 that the southwesterly block moved northwest as far as the rupture extended. If this be accepted, then the southerly net movement on the west side of the south end of the fault is due to the predominance of an earlier southerly movement. This agrees with the positive and certain earlier displacement of Loma Prieta. Accepting the southerly character of this earlier movement as certain, there is forced upon us the remarkable fact that the direction of displacement in the region about Monterey Bay is the reverse of that of the earlier movement for the region north of San Francisco Bay. This means that the earlier movement was distensive in character, displacing the territory to the north of San Francisco Bay northerly, and that to the south southerly while the vicinity of the Bay itself was relatively neutral. It appears, moreover, that the southerly displacement was differentially diffused, since the amount of displacement of the south side of Monterey Bay was notably greater than that of the north side, resulting in a widening of the Bay by about 10 feet.

Similarly the distance between Tanralpais and Black Mountain, both on the same side of the San Andreas rift, has been increased by a like amount. The significance of this general distension involved in the reversal of the direction of displacement to the north and south of San Francisco Bay, and of the differential character of this distension, without known rupture, at Monterey Bay and San Francisco Bay, can not at present be stated. The problem requires prolonged study and repeated measurements to secure the necessary data for a proper discussion. It is evident, however, that we are here confronted with some of the most interesting phenomena in the mechanics of the earth's crust, phenomena which call for deliberate investigation extending through years and decades and conducted on a wisely planned program.

## PROVISION FOR MEASUREMENT OF FUTURE MOVEMENTS ON SAN ANDREAS FAULT.

The extent of the movement on the San Andreas fault on April 18, 1906, was measured imperfectly and inexactly by offsets of fences, lines of trees, roads, pipes, dams, creeks, shore lines, etc. The distribution of the displacement in the immediate vicinity of the fault, the drag and compression of the soil, the uncertainty as to the former orientation of the lines offset, and other adverse conditions rendered the determinations unsatisfactory to a certain degree. With one exception, the measurements obtained in this way are suspected of being less than the true amount of relative displacement of the firm rocks below the surface materials.

With the object of obtaining a more exact measurement of any future movements that may take place on the same fault, the Commission caused to be established two sets of piers or monuments in the Rift, in proximity to the fault-trace, upon which instrumental observations could be obtained as to the amount of displacement. This was not done in anticipation of the recurrence of a large movement in the near future, but because it was suspected that there might be slight movements at the times of minor earthquakes, such as are fairly common. Such slight movements might, in the course of years, accumulate to an important amount, and yet the individual increments of the displacement escape notice unless refined methods of measurement are resorted to. It is hoped that the establishment of the monuments and the redetermination of their relative positions from time to time will enable future observers to ascertain whether or not there is a small progressive movement on the San Andreas fault, in addition to the larger movements which cause more violent earthquakes, such as those of 1857 and 1906. Besides serving this purpose, the movements will also be useful in any effort that may be necessary in future to determine with precision the amount of a large displacement.

The localities selected for the position of the two sets of monuments are Olema, Marin County, and Crystal Springs Lake, San Mateo County. These localities are about 40 miles apart on the Rift, and the fault-trace at both was confined to a very narrow zone in 1906, thus permitting the piers to be more closely grouped than at many other localities which for other reasons might have been chosen.

Each set of monuments consists of four concrete piers, established two on each side of the fault-trace of 1906. They are sunk in the ground to a depth of about 6 feet, and are founded either upon rock or upon a firm "hard-pan" arising from the decomposition of the underlying rocks. They rise from 2 to 3 feet above the surrounding surface. The establishment of the piers at Olema was intrusted to Mr. A. J. Champreux, of the Astronomical Department of the University of California, and those at Crystal Springs Lake were set in place by the officers of the Spring Valley Water Company, under the direction of its chief engineer, Mr. Hermann Schussler, who very kindly relieved the Commission of any expense connected with the operation. The piers at Olema are 13 inches square in cross-section, while those at Crystal Springs Lake are 18 inches square. To the summit of each of the piers is fixed a thick bronze plate 13 inches square, with suitable appliances for receiving a selected instrument in a constant position for successive measurements, and a device for determining a fixed point to which to measure. This plate is protected by a heavy iron cap, 14.5 x 14.5 inches, locked upon it, bearing the inscription:

S.E.I.C.  
To measure  
earth movements  
1906.

The instrument selected for the first and subsequent measurements is a 10-inch alt-azimuth, the property of the University of California, and the key of the protecting caps is at present in the safe keeping of the same institution.

In order to render the monuments thus established available for future measurements of displacement, it was necessary to have their present relative positions established with precision. This work was very kindly undertaken for the Commission by Mr. B. A. Baird, Assistant, Coast and Geodetic Survey, a report from whom follows, setting forth his methods and results:

#### RELATIVE POSITIONS OF THE MONUMENTS.

By B. A. BAIRD.

OLEMA.

*Description of monuments.* — The monuments at Olema are on Mr. Skinner's ranch, just a little north of the dwelling-house. The two piers west of the fault-trace are in an orchard on level ground, but the other two, which are just east of the road, are on a hillside, the northeast monument being about 15 feet higher than any of the others. In order to measure and observe between the northwest monument and the southeast monument, a trench about 3 feet deep had to be dug thru the embankments on both sides of the road and somewhat into the traveled portion as well. Some clearing of brush was necessary in order to make the northeast monument and the southwest monument intervisible.

The relative positions of the four monuments are shown in the diagram, fig. 44. The lengths of the three heavy lines were determined by measurement. The measurements of the other three lines were considered impracticable, on account of the great height of the northeast monument above the others, as compared with the short distances between them and it. By means of the three measured lines, however, a double determination is obtained, thru the observed angles, of each of the three lines not measured by the steel tape.

The lines were cleared sufficiently so that all four of the monuments could be occupied with a theodolite, and then all of the lines were observed, including the diagonals. In order that future movements may be readily detected by means of observed angles, the centering of the instrument was considered to be of the greatest importance, especially for such very short lines as these. A bronze plate had been constructed and set up on each monument, especially designed for supporting in position the Fauth 10-inch alt-azimuth instrument of the Civil Engineering Department of the University of California.

A sketch of the plate is shown in fig. 45. The spindle which screws into the central socket of the plate is shown in fig. 47, and the iron cap which protects the plate when the spindle is removed is shown in fig. 46. Referring to the sketch of the plate, it will be seen that there are three lugs, or foot-plates, standing upon and attached to it. In one is a groove (vertex of angle at bottom), and in one a hole (inverted cone), while the third has simply a smooth surface. This arrangement prevents any binding of the foot-screws of the instrument, and insures that it will always be set in the same position in successive measurements.

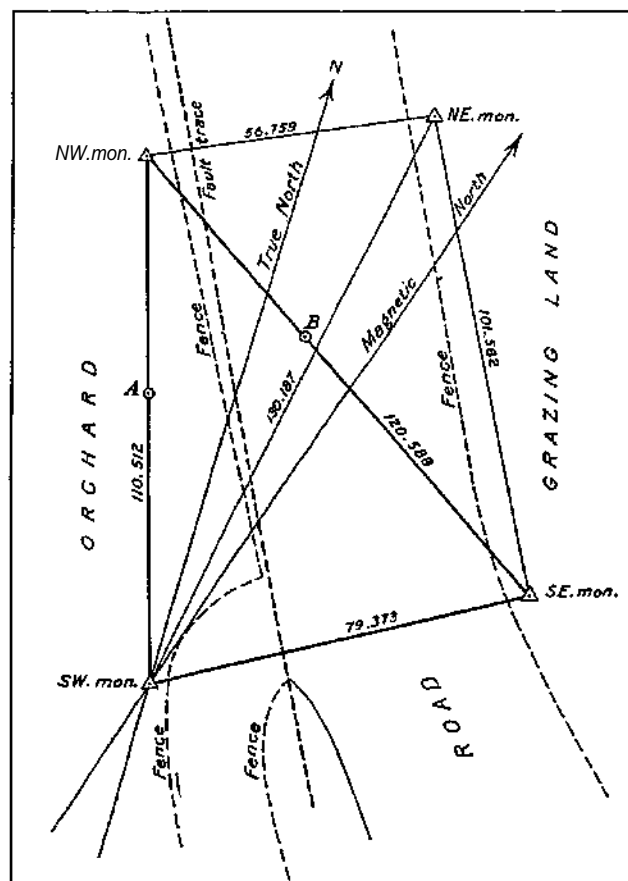

FIG. 44. — Monuments at Olema.

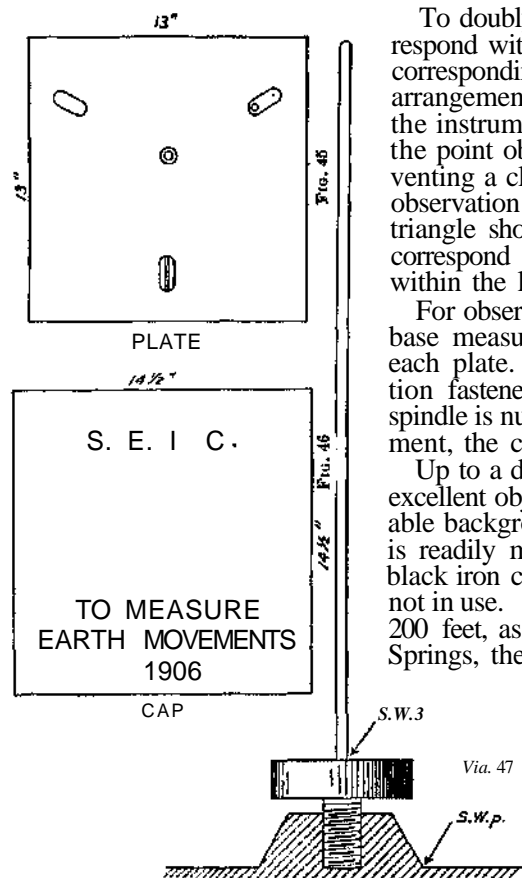

FIG. 46. — Diagram of bronze plate on monuments.

FIG. 47. — Diagram of iron caps protecting plates.

FIG. 47. — Diagram of spindles to be attached to plates.

To doubly insure this, one of the lugs is marked to correspond with a particular support of the theodolite, the corresponding support being similarly marked. This arrangement further insures that even tho the center of the instrument does not correspond exactly with that of the point observed upon (for each monument), thus preventing a closing of the triangles within the accuracy of observation (that is, that the sum of the 3 angles of each triangle should equal  $180^\circ$ ), the angles obtained will still correspond with each other in successive observations within the limit of observational errors.

For observing upon, and also for reference points in the base measurements, a spindle has been constructed for each plate. This spindle screws into a cup-like projection fastened upon the plate for a center-mark. Each spindle is numbered to correspond with a particular monument, the corresponding number being upon the plate.

Up to a distance of about 200 feet these spindles make excellent objects to observe upon, provided there is a suitable background. A background that can not be surpassed is readily made by propping up behind the spindle the black iron cap which covers and protects the plate when not in use. When the distances are greater than about 200 feet, as is the case with the longer lines at Crystal Springs, the best object to observe upon can be made by

whittling the end of a lead pencil to fit into the cup and then wrapping the pencil with a little white cloth. In this case the background should be the same as before. In any event, if tape measurements are contemplated, the spindles should be taken along, in order that they may be used as reference marks in those measurements.

*Leveling record.* — In the following tabulation, *S.W. p* means the top of the bronze plate on the southwest monument, alongside the spindle bowl or cup near the center.

A corresponding point was taken on each monument to show the relative elevations to be retained for future reference.

*S.W. s* is the top surface of the spindle hub, screwed into the socket, made for marking the center on the same plate. These points were taken to show differences of elevation of points used in the tape measures in the base-lines, and are of no value beyond this.

In computing the elevations, the top of the southwest monument was arbitrarily taken as 10 feet, and the other elevations are corrected to correspond with this datum plane.

The spindle bowl is not in the center of the plate, owing to the position of the lugs, so that the point leveled upon representing the level of the plate is on the side of the spindle bowl next to the center of the plate.

The level used was a Troughton and Simms dumpy level with compass attachment.

[Elevations in feet. — Mean results.]

	FIRST MEASURES.	SECOND MEASURES.	MEAN.	BASE-LINE ELEVATIONS.	DIFFERENCES OP ELEVATION.
S.W. p . . .	10.000	10.000	10.000	.....	.....
S.W. s . . .	10.075	10.076	10.076	10.076	.....
Stake A . . .	7.465	7.462	7.464	7.464	- 2.612
N.W. p . . .	8.006	8.004	8.005	.....	.....
N.W. s . . .	8.057	8.053	8.055	8.055	+ 0.591
Stake B . . .	11.694	11.690	11.692	11.692	+ 3.637
S.E. p . . .	11.389	11.390	11.390	.....	.....
S.E. s . . .	11.455	11.456	11.456	11.456	- 0.236
N.E. p . . .	25.877	26.877	25.877	.....	.....
S.W. s . . .	.....	.....	.....	10.076	- 1.380

The relative elevations of the four monuments, taking the center of the plate in each case, are as follows:

	FEET.
Southwest monument . . . . .	(assumed) 10.000
Northwest monument . . . . .	8.005
Northeast monument . . . . .	25.877
Southeast monument . . . . .	11.390

*Base-line measures.* — B. A. Baird in charge, reading rear end of tape and recording. R. S. Badger, forward end of tape and reading thermometer. Charles Evans (laborer), steadying spring balance attached to end of tape and watching tension of 10.5 lbs. The tape used, a 100-foot steel tape, G. M. Eddy and Co., Catalogue No. 703; was stamped on reel "No. 1" for identification in future use. Its width is 0.272 inch; its thickness 0.010 inch; and its weight per foot 3.8324 grams or 0.00845 lb. This tape, on May 1, was compared with the standard tape at the University of California, a long level stretch on the "bleachers" being used for the purpose. The standard tension of 10.5 lbs. was adopted, and no difference in the lengths of the tapes could be detected.

The standard tape, N.B.S. No. 8, is marked only at zero and 100 feet. The comparisons were made between these marks, and the equality of zero to 50 feet and 50 to 100 feet was measured on the tape used in the base-measures, there being no measurable difference.

The constants of the standard tape, N.B.S. No. 8, are: Temperature of observation, 64.6° F.; Tape supported thruout entire length; tension, 10.5 lbs. avoirdupois; resulting values of spaces at 62° F., assuming coefficient of expansion = 0.0000063 per degree F. are zero to 100 feet = 100 feet 0.00 inch.

FORMULA AND CONSTANTS USED IN BASE-LINE COMPUTATIONS.

- $r - T - i - \frac{h^2}{2P} - \frac{w d^2}{2P}$ ,  
Correction for Level =  $-\frac{r-j}{2} - \frac{h^2}{2P}$ , where  
 $h$  = difference of elevation of ends of tape.  
 $d$  = distance between supports.
- Correction for Temperature =  $-\frac{I(T-t)e}{P}$ , where  
 $I$  = length of line corrected for.  
 $T$  = standard temperature = 62° F.  
 $t$  = mean temperature of tape.  
 $e$  = coefficient of expansion = 0.0000063 per degree F.
- Correction for Sag =  $-\frac{I}{2P} \cdot \frac{w d^2}{P}$ , where  
 $w$  = weight of tape per foot = 0.00845 lb. per foot.  
 $P$  = standard tension of 10.5 lbs., the same as used in measures.  
 $d$  and  $I$  same as above.

From the above,  $\frac{1}{24} (|J = \wedge - (\wedge f j \wedge p j \wedge 0.00000002700.$

The correction for *pull*, accounting for elasticity of tape, is not necessary, since the standard tension was used in the measures.

*Level correction.* — In taking the measurements, the center of the spindle, firmly screwed into the cup on the bronze plate, as shown in the diagram, fig. 47, was the reference mark on the monuments.

The ordinary correction for level,  $\frac{h^2}{2P}$ , is not sufficiently accurate when the differences are large, and a second correction has been allowed for. In the corrections at Crystal Springs, even third approximations are necessary.

The computed values of the measured lines are summarized as follows:

[Computed lengths of bases (feet).]

	FORWARD.	BACKWARD.	MEAN.
N.W. to S.W. Mem. . . . .	110.1528	110.5115	110.512
N.W. to S.E. Mon. . . . .	120.5800	120.5878	120.588
S.E. to S.W. Mon. . . . .	79.7728	79.3725	79.373



## CRYSTAL SPRINGS LAKE.

*Description of stations.* — These monuments are about 7 miles northwest of San Mateo on the eastern shore of Crystal Springs Lake, the reservoir of the Spring Valley Water Company. The location is about a mile southeast of Camp Sawyer, which is on the west side of the lake at a point where the lake is very narrow and is spanned by a bridge, close to the northern end.

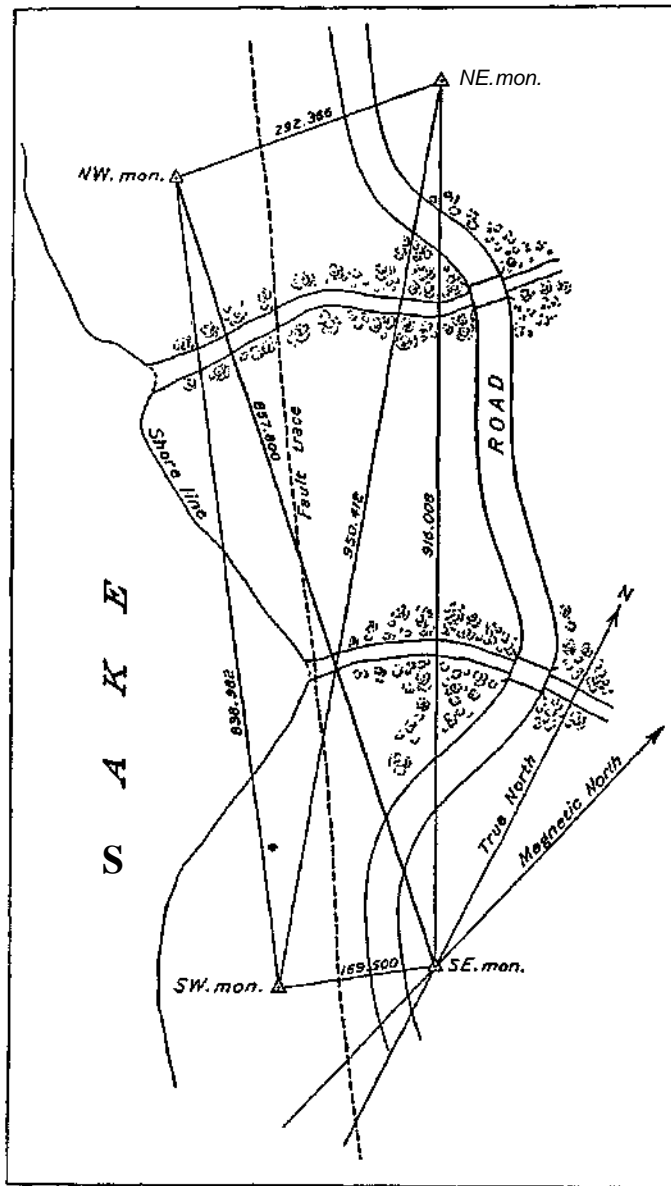

FKJ. 48. — Monuments at Crystal Springs Lake.

As will be seen from the leveling record, and from the accompanying rough sketch, fig. 48, the ground is very uneven, and the measurement of a base-line was executed under considerable difficulty. The line measured, which was the only practicable one, crosses two ravines and comes up toward the southeast monument, over a very steep road embankment. Considerable clearing of brush was necessary in order to cross the ravine near the northwest monument. On account of the large differences of level between the base-line stations in some places, the leveling had to be done with extreme care, there being at one place a rise of 11.5 feet in 80 feet, and, next to the road embankment, a rise of about 6 feet in 20 feet.

The plates, spindles, and caps are the same as those described under "Description of Monuments" at Olema. The distances between these stations being too great to observe upon the spindles with advantage, pencils were wrapt with white cloth and set in the spindle cups upon the plates, the bronze protecting caps being used for background, as in the Olema measurements.

*Base-line measures.* — The stakes, made long enough to stand above the grass, were lined in with the alt-azimuth instrument, and to avoid the possibility of errors they were all numbered on top with a blue crayon. The stakes were made of redwood, and the method of marking was to stick a pin straight down in the top of each at the marking edge of the tape. The tape used was marked to hundredths of feet the entire length, the thousandths being estimated. The measurements were so taken as to avoid estimating the thousandths, excepting on the last measure, the mark being arbitrarily placed at the nearest convenient tenth of a foot on the top of each forward stake.

As the diameter of the pins used was almost exactly the same as the width of the 0.1-foot marks on the tape, the marking could be done with exceptional accuracy, especially by holding the eye directly over the mark in such a way that there would be no parallax. The spring balance was fastened to the forward end of the tape, and steadied by means of a cord looped so as to slip up and down on a pole, held by a man who at the same time watched the tension. To avoid any pulling against the stakes, the height of the tape was regulated by means of the loop so as just to graze the top of the stake. All the marking was done at the forward end of the tape, the officer in charge at the rear end simply steadying on the mark of the previous measure and then reading the tape.

The lengths of the base joining the southeast and northwest monument resulting from the measurements are the following:

	FEET.
First measure. . . . .	857.8020
Second measure. . . . .	857.7988
Mean. . . . .	857.800

*Relative elevations.* — By means of precise leveling the relative elevations of the four fixed monuments, taking the center of the top of the bronze plate in each case, were found to be as follows:

	FEET.
Northwest monument. . . . .	(assumed) 50.000
Northeast monument. . . . .	86.513
Southeast monument. . . . .	75.787
Southwest monument. . . . .	46.113

*Method of observing angles.* — The instrument used was a 10-inch alt-azimuth theodolite, carrying two micrometers 180° apart. Each micrometer head is divided to represent seconds of arc, enabling the observer to estimate to tenths of seconds of arc at each reading. In taking the observations, each micrometer was read to correspond with two consecutive 5-minute divisions, one being back of the reference mark and one in front. The corrections for "run" at each station were based upon the observations themselves, the mean of all observations at the first two monuments being taken both at Olema and at Crystal Springs. In order to eliminate all possible instrumental errors, the observations were, in general, taken in four sets, having for the initial reading of each set, 0°, 90°, 45°, and 135°, respectively; making for the reversal of the telescope, without changing the setting of the circle, the corresponding readings of 180°, 270°, 225°, and 315°.

Thus, upon each station there were eight pointings of the instrument, representing eight portions of the circle equally divided. Since for each of these pointings there are two micrometers, each giving two readings of the thread, there were in reality 32 micrometer readings for each observed station. The above statements apply fully at Crystal Springs, but at Olema one micrometer was not in condition to use, so that the Olema observations, while constituting the same number of telescope pointings, represent for each observed station but 16 micrometer readings.

At Olema, on account of the very small distances between the monuments, large changes of focus were necessary for the different pointings. This, combined with the large differences of elevation, and lack of perfect centering of the instrument on the plates to correspond with the positions of the spindles, prevented the triangles from closing to a very high degree of accuracy. Still, when these discrepancies are reduced to errors of distance, they become practically inappreciable.

At Crystal Springs, where the lines are much longer, the closing of the triangles was very good. The correction for each angle, in order to make the sum of the angles of each triangle equal to  $180^\circ$ , was on the average only about one second of arc. This goes to indicate that this instrument, when properly used, is capable of excellent results. At Crystal Springs a least square reduction of the observations has been made, but the angles and distances thus computed are almost identical with those of the original computation.

At Olema, where the three lines having the least differences of level were measured, the diagonal between the northwest monument and the southeast monument (being best suited for computation) was taken as a base for computing the other two measured sides. The means of the computed and measured distances of these two sides, together with the direct measure of the above-mentioned diagonal, were taken as the best measures for computing the unmeasured sides. The lengths of the three unmeasured sides, therefore, depend not only upon the observed angles, but upon the lengths of the three bases, as indicated above. This method gives the measured distances and observed angles about equal weight, the angles being corrected for each triangle according to what is known as the "field adjustment." As above noted, however, it is very doubtful if the angles are entitled to as much weight as the measured distances, and hence, it was decided to retain the exact values of the three measured distances, and make a "least square" adjustment of the angles of the quadrilateral to correspond.

The three measured sides being assumed as fixed, the three angles of the triangle N.W. Mon., S.E. Mon., S.W. Mon., can each have but one value, and these values have been computed from the three sides. These three sides and the corresponding angles remaining fixed, an adjustment is made between the remaining angles and the three unmeasured sides, so as to fulfill all the geometrical conditions, giving at the same time the most probable values, according to the theory of "least squares."

*Abstracts of horizontal angles.* — In the abstracts of horizontal angles tabulated below, the first set of angles given under the heading "Observed" are the means of angles taken directly from the original records. The column headed "Field Adjustment" shows the angles as they appear in the field computations after the angles of each triangle have been corrected to sum up  $180^\circ$ , giving the same correction to each angle in a particular triangle. This adjustment, which is the usual one made in the original computations, does not account for the other geometrical conditions required for the rigid solution of a quadrilateral, but when the errors in the angles are small, the resultant distances, especially if short, will be very near the truth. The column headed "Least Square Adjustment" shows the angles computed so as to fulfill all the geometrical conditions, giving their most probable values according to the theory of "least squares."

In future measurements, it will not be necessary to repeat the base-measurements unless the angles show some change, for by occupying all the stations, any change that could be detected by tape measurement will at once show in the angles. When, however, the angles indicate any change, then a remeasurement of at least one line will be necessary.

MEASUREMENT OF FUTURE MOVEMENTS ON SAN ANDREAS FAULT. 159

[Abstract of Horizontal Angles. — Oleraa. Mean of eight pointings on each station.]

	OBSERVED.	FIELD ADJUSTMENT.	LEAST SQUARE ADJUSTMENT.
At N.E. Monument:			
S.E. Mon. to S. W. Mon. . . .	37° 33' 23.6"	24.6"	37° 33' 26.7"
S.W. Mon. to N.W. Mon. . . .	57 24 50.4	61.8	57 25 21.6
S.E. Mon. to N.W. Mon. . . .	94 58 14.0	22.1	94 58 48.3
At S.E. Monument:			
S.W. Mon. to N.W. Mon. . . .	63 12 13.4	17.6	63 12 29.7
N.W. Mon. to N.E. Mon. . . .	27 57 59.1	67.2	27 57 48.6
S.W. Mon. to N.E. Mon. . . .	91 10 12.5	13.5	91 10 18.3
At S.W. Monument:			
N.W. Mon. to N.E. Mon. . . .	25 38 40.6	52.0	25 38 41.9
N.E. Mon. to S.E. Mon. . . .	51 16 20.9	21.9	51 16 15.0
N.W. Mon. to S.E. Mon. . . .	76 55 01.5	05.8	67 54 56.9
At N.W. Monument:			
N.E. Mon. to S.E. Mon. . . .	57 03 22.6	30.7	57 03 23.1
S.E. Mon. to S.W. Mon. . . .	39 52 32.3	36.6	39 52 33.4
N.E. Mon. to S.W. Mon. . . .	96 55 54.9	66.2	96 55 56.5

[Distances in feet.]

	MEASURED.	COMPUTED.	MEAN.	LEAST SQUARE ADJUSTMENT.
S.E. Mon. to N.W. Mon. . . .	120.588	.....	120.588	120.588
S.E. Mon. to S.W. Mon. . . .	79.373	79.373	79.373	79.373
S.W. Mon. to N.W. Mon. . . .	110.512	110.508	110.510	110.512
N.E. Mon. to N.W. Mon. . . .	.....	56.768	56.768	56.759
N.E. Mon. to S.W. Mon. . . .	.....	130.191	130.191	130.187
N.E. Mon. to S.E. Mon. . . .	.....	101.584	101.584	101.582

[Abstract of Horizontal Angles, Crystal Springs Lake. Mean of eight pointings on each station.]

	OBSERVED.	FIELD ADJUSTMENT.	LEAST SQUARE ADJUSTMENT.
At N.W. Monument:			
N.E. Mon. to S.E. Mon. . . .	92 01' 49.2"	49.5"	92° 01' 49.9"
S.E. Mon. to S.W. Mon. . . .	11 23 43.5	43.5	11 23 44.9
N.E. Mon. to S.W. Mon. . . .	103 25 32.7	34.8	103 25 34.8
At N.E. Monument:			
S.E. Mon. to S.W. Mon. . . .	10 12 21.8	20.1	10 12 19.0
S.W. Mon. to N.W. Mon. . . .	59 09 45.1	47.2	59 09 47.9
S.E. Mon. to N.W. Mon. . . .	69 22 06.9	07.3	69 22 06.9
At S.E. Monument:			
S.W. Mon. to N.W. Mon. . . .	77 57 38.1	38.1	77 57 37.0
N.W. Mon. to N.E. Mon. . . .	18 36 02.8	03.2	18 36 03.2
S.W. Mon. to N.E. Mon. . . .	96 33 40.9	39.2	96 33 40.2
At S.W. Monument:			
N.W. Mon. to N.E. Mon. . . .	17 24 35.9	38.0	17 24 37.3
N.E. Mon. to S.E. Mon. . . .	73 14 02.4	00.7	73 14 00.8
N.W. Mon. to S.E. Mon. . . .	90 38 38.3	38.4	90 38 38.1

[Distances in feet.]

	MEASURED.	FIELD COMPUTATION (BASE-LINE).	LEAST SQUARE ADJUSTMENT.
S.E. Mon. to N.W. Mon. . . .	857.800	.....	857.800
N.E. Mon. to S.W. Mon. . . .	.....	950.4*14	950.412
N.E. Mon. to N.W. Mon. . . .	.....	292.368	292.366
N.E. Mon. to S.E. Mon. . . .	.....	916.008	916.008
S.W. Mon. to S.E. Mon. . . .	.....	169.500	169.500
S.W. Mon. to N.W. Mon. . . .	.....	838.984	838.982

## ISOSEISMALS: DISTRIBUTION OF APPARENT INTENSITY,

### INTRODUCTORY.

In the study of earthquakes the distribution of the intensity of the shock over the region affected is usually an important part of the investigation. The intensity is inferred, as a rule, from the records of instruments established for the purpose, and from the effect upon persons, loose objects, and structures. In the region affected April 18, 1906, however, seismograph instruments were very few, and the distribution of the intensity of the shock has been determined largely by the effects noted. These effects are graded in various convenient scales and the gradation of intensity is indicated upon maps in the form of lines or curves, known as isoseismal curves, which express, as well as the data available will permit, zones or belts of equal intensity more or less concentric to the point or line above the seat of disturbance. The purpose of plotting such isoseismal curves is to locate approximately that portion of the earth's surface immediately above the seat of the disturbance. In a discussion of the ideal case, the latter is supposed to be a point or *centrum*, and the place above it at the surface is called the *epicentrum*. The increase in our knowledge of earthquakes in recent years has, however, made it clear that the seat of disturbance is rarely if ever a point, but is usually distributed over a plane of rupture in the earth's crust. When, this plane of rupture is of small extent, as frequently happens, the terminology is little affected by the use of the expressions *centrum* and *epicentrum* in the discussion of the phenomena; but where, as in the larger earthquakes, the plane upon which movement in the earth's crust takes place has a great horizontal extent, then these terms become misnomers and tend to obscure the facts. In the present case the inappropriateness of the terms *centrum* and *epicentrum* is glaringly apparent and they will, therefore, be avoided in this discussion.

In the case of the California earthquake, the plotting of isoseismal curves for the purpose of discovering the region on the surface above the seat of the disturbance is in a large measure obviated by the fact that the rupture in the earth's crust is revealed at the surface in the form of a fault traceable practically continuously for 190 miles, and probably continuously for 270 miles. This fault is undoubtedly the principal seat of the movement which caused the earthquake. Notwithstanding this fact, the study of the distribution of intensity is a matter of importance. It is highly desirable, where the plane of rupture is open to the surface and its trace is definitely ascertained, to plot the isoseismal curves, since their disposition under these circumstances may illuminate the general method of determining the position of a deep-seated fault which causes an earthquake, but is not apparent at the surface. It may at least contribute to a definition of the limitations of the method.

It is, moreover, desirable that the distribution of the intensity of the shock should be determined as accurately as possible, since we can not safely assume that the main fault, which appears as a rupture of the earth's crust from San Benito County to Humboldt County, is the only one which occurred on the morning of April 18. Indeed there are *a priori* grounds for believing that more than one dislocation of the earth's crust occurred at the time of this great disturbance of the equilibrium of the stresses within it. If, in a region where stresses have accumulated to nearly the snapping point, a rupture is suddenly effected in one place, it seems probable that the jar thus generated might precipitate ruptures in neighboring parts of the region under similarly high stresses. It appears, therefore, to be highly desirable to plot the gradations of intensity for the region affected; not to discover the trace of the main fault, which is well known, but to see if such gradations indicate auxiliary faults in neighboring territory which did not appear as ruptures

at the surface. In attempting this task, certain conditions which militate against the accuracy of the results and others which affect their interpretation should be stated.

In the first place, the scale upon which the gradation of intensity is indicated, that known as the Rossi-Forel scale, is more or less arbitrary. At the outset of the inquiry, the Commission revised and simplified this scale somewhat, with the object of adapting it for general use, and its present form, as amended by the Commission, is as follows:

- I. *Perceptible*, only by delicate instruments.
- II. *Very slight*, shocks noticed by few persons at rest.
- III. *Slight shock*, of which duration and direction were noted by a number of persons.
- IV. *Moderate shock*, reported by persons in motion; shaking of movable objects; cracking of ceilings.
- V. *Smart shock*, generally felt; furniture shaken; some clocks stopt; some sleepers awakened.
- VI. *Severe shock*, general awakening of sleepers; stopping of clocks; some window glass broken.
- VII. *Violent shock*, overturning of loose objects; falling of plaster; striking of church bells; some chimneys fall.
- VIII. Fall of chimneys; cracks in the walls of buildings.
- IX. Partial or total destruction of some buildings.
- X. Great disasters; overturning of rocks; fissures in surface of earth; mountain slides.

It is apparent that the scale leaves room for wide variation in the personal equation. Different reporters interpret the same experiences and the same phenomena differently. It was also found that in the periphery of the region affected, where the earth waves were of slow period, pendent objects and liquids were more sensitive indicators of earth movement than direct perception by individuals, altho the latter is placed first in the scale. Prof. G. D. Louderback, who reported upon the intensity of the shock in the region east of the Sierra Nevada, makes the following pertinent comment upon this point:

In the towns along the east base of the Sierra Nevada and within 25 or 30 miles of the base, the shock was distinctly felt, movable objects were seen to swing and heard to bump or rattle, and a very small number of persons were awakened. Farther east the most notable feature of the reports is that wherever the effects of the earthquake were made evident, the physical signs, such as the swinging of suspended objects, etc., were described almost to the exclusion of direct physiological effects. This is apparently at variance with the principle upon which the Rossi-Forel scale is founded, as the first three grades of intensity are based on feeling, the visible disturbance of objects not beginning till grade IV is reached. Perhaps the most important physical sign reported is the disturbance of smooth water surfaces. In five instances, at three different localities, ditch tenders or irrigators noticed an agitation of quiet water surfaces, and that water lightly splashed against the sides, as if from low waves, or as in a vessel of water when it is slightly tilted. As the morning was clear and entirely without wind, it impressed them as peculiar, and the matter was reported when they went to breakfast. The suggestion of one that something peculiar had happened, and of another that it was an earthquake, was each in its place the incitement of sallies of wit at the expense of the reporter. News of the California earthquake reached these places several hours afterwards and the time was then found to agree as closely as determinable with the phenomena of the morning. In each of the cases, however, it was reported that no shock was felt. It is suggested that with moderately long waves such surfaces might prove very sensitive indicators of intensities down to the lowest degree on the scale.

The movement of liquids in vessels, ponds, lakes, or streams, is not included in the scale, altho numerous reports were made of such movement and estimates as to the intensity of the shock were based thereon. The stoppage of clocks appears to be a very uncertain criterion of intensity. In the 6th, 7th, 8th, and 9th degrees of the scale, wherein damage to buildings is relied upon for an estimate of the intensity, two important factors tend to vitiate the conclusions arrived at as to the comparative intensity. These are (1) the great variability of the character of the structures and (2) the character of the ground upon which they are built. The scale was probably designed originally for regions where brick and masonry structures prevail, while in California wooden structures are by far

the most common. The latter, by reason of their greater elasticity, are usually much better adapted to withstand the wracking movement of an earthquake shock than are brick and masonry walls. The intensity, as inferred from a region of wooden buildings, would, therefore, in general appear to be less than that for a region of brick or masonry structures. Even among the latter, and among the brick chimneys of wooden houses, which were so generally used as indicators of intensity, there is great variation in strength due to the variation chiefly in the character of the mortar used in their construction.

Along river bottoms and on valley floors, particularly where the ground water is abundant, structures were much more susceptible to damage than similar structures founded on the firm rocks of the valley slopes. This apparently high intensity of the shock in the valley lands was in part due to an actual slumping of the ground, which wracked the buildings independently of any elastic vibration communicated to them from the ground.

Finally, in grade X of the scale, fissures in the ground are taken as a criterion of the highest grade of intensity, when in reality such fissures have under different conditions very different values from this point of view. The fissures which extend down into the earth's crust, and are due to its actual rupture on a fault-plane, are of course significant of the highest degree of disturbance usually experienced in earthquakes; but those cracks and fissures which occur in valley bottoms, due to the slumping of soft material toward the stream trench, or those cracks which are associated with landslides, in those cases where the landslide was imminent and was merely precipitated by the earth jar, are superficial phenomena and do not necessarily indicate so high a degree of intensity as that marked X on the scale. It therefore becomes necessary to discriminate such fissures, and this was not always done in the reports sent in to the Commission.

These various imperfections in the scale used for grading the intensities would of course be minimized if the entire field were examined and reported upon by one observer. The personal equation would in that case, for practical purposes, be constant. But when the observations were made over so vast a field by a great number of persons, so diversely qualified for the work, the errors are necessarily numerous.

Added to this are the large gaps in the records, due to the scant population in the more mountainous parts of the region affected. In these thinly populated tracts, there is not only an absence of individual observations at the time of the earthquake, but also a lack of structures which would reveal to subsequent examination the effects of the shock.

It will thus be apparent that any effort to map the distribution of the intensity of the earthquake can only yield rough approximations to the actual facts. Yet such approximations have their value, and the Commission has not been discouraged by the imperfections of the method from applying it to the full extent permissible under the circumstances. The results are given graphically on the isoseismal map which accompanies this report. (Map No. 23.)

In compiling this map, it has been found best to plot the intensities upon the basis of a literal interpretation of the Rossi-Forel scale, as regards damage to structures. It results from this that in the river bottom the curves represent zones of equal destructive effects, but not necessarily zones of equal intensity, interpreted in terms of acceleration of the vibratory movement of the earth. In these tracts we are confronted with the question as to whether the locally high destructive effects were wholly due to the character of the ground, as in part they certainly were, or whether these may not be ascribed in part to local auxiliary faults in the earth's crust which did not appear as ruptures at the surface. This question will receive special consideration in the sequel, when the facts have been more fully set forth.

It is now proposed to describe somewhat in detail the effects of the earthquake which serve as the basis of the isoseismal map, beginning at the north and going southerly.

## SOUTHERN OREGON.

The most northerly point on the coast for which we have a record of the earthquake shock having been felt on the morning of April 18 was at Coquille, Oregon. Here Mr. E. S. Larsen reports that Judge Harlocker was awakened by the shock at about 5 o'clock. Mr. Wilson and his wife were awakened and noticed the cord of an electric lamp swinging east and west. The regulator in Mr. Wilson's jewelry store, facing east, stopt. Others were awakened. Mr. Larsen also reports that the shock was felt at Bandon, and that at Kerby some claim to have felt it.

At Williams some sleepers were awakened. At Glendale the shock was felt by about 10 per cent of the people. Reports have been received from Nehalem, Tellamook, Newport, Salem, Gardiner, Drain, and Eugene to the effect that the shock was not felt. At Port Orford a slight tremor was felt.

Inland from the coast the following observations are reported by Mr. G. A. Waring:

At Grant's Pass the shock was slightly felt. At Medford a few people felt it, and one woman was awakened by a slight swinging of the partly open door. At Ashland the shock was lightly felt and the sulfur springs nearly doubled their flow for 24 hours, and then slowly returned to normal condition. A few people in Klamath Falls claim to have felt the vibration, but no clocks in a jewelry store were stopt. In Langell's Valley few, if any, felt the shock, but water in an east-west trough was noticed moving slowly from end to end. From two different sources it was reported that at Merrill the shock was distinctly felt, and two old buildings in this place are said to have been shaken down. It was reported that the shock was felt in Drew's Valley, but the people at the stage station there did not feel it nor know of any one in the valley who did. At Lakeview a seconds-pendulum clock facing south in a jeweler's store stopt. The clock was about half run down, it being near the middle of the week. The jeweler says it had never stopt before. One other clock, a spring one, was reported to have stopt in this town, and two or three people claimed to have felt the vibration. Mr. Waring could not, however, find any of these people. At Paisley no shock was noticed on April 18, but on Thursday, April 19, about 1<sup>h</sup> 30<sup>m</sup> A.M., a tremor was felt, strong enough to generally awaken people, and during the next hour and a half three more shocks were felt. Considerable excitement was caused, some people going out-of-doors and one rather delicate woman being made sick. But no doubt the fact that news of the San Francisco disaster reached here late the previous afternoon greatly increased the notice paid to these vibrations. Mr. Waring could learn of no clocks being stopt, the only material evidence being the shaking of a lamp from the edge of an unsteady center table. Enquiry failed to elicit any evidence of a shock having been felt at Bly, Bonanza, Summer Lake P.O., or Silver Lake.

Mr. Waring closes his report with the following general statement:

Judging from all I could learn, I think over most of south central Oregon the vibration was hardly perceptible to people awake. At Paisley and at Merrill stronger shocks were felt. The shock at Paisley was peculiar in being early Thursday morning, April 19, a sort of "sympathetic" shock. No information concerning the time of the shock at Merrill was obtained, but I think it was on Wednesday morning at the time of the great quake. The greater intensity of shock at these two places is perhaps due to the underlying formation. Paisley is built on river ground at the edge of the Chewancan Marsh. Merrill lies in or near Langell's Valley, by Lost River, which here sinks and flows thru swampy land in several places.

## KLAMATH MOUNTAINS AND NORTHEASTERN CALIFORNIA.

*Crescent City, Del Norte County* (George Sartwell).—The earthquake was felt as a northerly and southerly temblor lasting about 5 seconds, with a short intermission. Several pendulum regulators stopt. In the easterly portion of the town the water in a mill-pond was noticed to surge back and forth, disturbing the logs. The ground in the vicinity is of a springy nature. On the morning of April 23 another shock was felt, and



reported by some to be more severe than that of April 18. But Mr. Sartwell, having experienced both shocks, is of the opinion that the shock of April 18 was the heavier. The shock of April 23 was westerly and easterly, and a regulator clock in the shop of D. S. Sartwell, watchmaker, that stopt on April 18, was not stopt on April 23. The same action took place in the mill-pond as on the 18th. Many people felt neither shock. Each time there was a cessation for a few moments of the surf beating on the shore.

*Klamath, Humboldt County* (C. H. Johnson). — There were two shocks, the first being the hardest, and the direction of movement from east to west. The first movement seemed to lift up, the second to settle back and shake. No objects were thrown down.

Prof. A. S. Eakle reports that at Trinidad a severe shaking up was experienced, but the shock, according to the residents of the place, did no damage.

Mr. P. L. Young, M.E., who was in Eureka on the morning of April 18, shortly afterward traveled thru a portion of the Klamath Mountains. He reports that the shock was felt at Arcata, Blue Lake, and up Redwood Creek to Hower's. On the Bald Hills, at an altitude of 3,300 feet, the shock was heavy. At Martin's Ferry, on the Klamath River, two trees were shaken down. It was felt at Weitchpec, at the junction of the Trinity and Klamath Rivers, at Orleans, Somes Bar at the junction of the Salmon and the Klamath Rivers, at Bennett's at the forks of the Salmon River, and at Gilta, a mining camp in southwestern Siskiyou County, about 3,300 feet above sea-level. Seven miles from the latter place, at Brooks, in the extreme northwest corner of Trinity County, at an altitude of 4,800 feet, the shock is described as heavy. At Hower's, on the night of April 22, Mr. Young experienced another very perceptible shock.

*Peanut, Trinity County* (Mrs. Ellen Diller). — Mrs. Diller was in bed on the morning of April 18, partially awake, when she was aroused by hearing a heavy table dragged across the floor, altho she is quite hard of hearing. Attached to the ceiling of the room was a piece of wire about 3 feet long, to which a basket for flowers is sometimes attached. She noticed this wire swinging northwest-southeast thru a space of 7 inches, and thought the wind was blowing. The house shook as if a heavy person were walking in the entry. The clock was stopt, the clock facing the east and the pendulum length being 5.5 inches. Mr. John W. Diller at the time of the shock was awake in bed in a mining camp bunk in a board shack about 8 miles east-northeast of Peanut. It seemed to him as if some one were pushing or pulling the side of the shack off. The man in the bunk below him was awakened but other sleepers in the shack were not.

*Montague, Siskiyou County* (G. H. Chambers). — There was one shock, the estimated duration of which was 30 seconds. The apparent direction of movement was east and west. The shock was strong enough to rattle windows, to cause beds to move, and suspended objects to swing. One clock was stopt.

*Gazelle, Siskiyou County* (O. F. Dyer). — Many persons in bed felt a light sensation. One clock in a brick store was stopt. The vibration was southeast and northwest.

*Sissmi, Siskiyou County*. — Press reports state that some windows were broken and that water in the Southern Pacific Railway tank spilt out.

*Dunsmuir, Siskiyou County* (A. J. Pictet). — Doors and windows rattled.

*Etna Mills, Siskiyou County* (May Lemon). — Several clocks stopt and some plastering was cracked.

Slight shocks are also reported from the Black Bear, Cantara, and Hornbrook, Siskiyou County. At Sawyer's Bar a few clocks were stopt. At Upton a water tank 40 feet high turned to the west, tipping some water out, and then went back to the upright position, according to a report by G. R. Dixon. He was awakened by his building swaying north and south. A rocking chair swayed in the same direction, as did hangings on north and south walls. This was followed by more complex movements, giving rise to nausea.

*Denny, Trinity County* (E. E. Ladd). — The foot of the bed was raised, and then the head, indicating that the shock came from south to north. This was followed by a tremble which caused a rocking motion.

*Big Bar, Trinity County* (W. A. Pattison). — Mr. Pattison was in bed in a very strong block-house, which shook and made a crackling noise. His pendulum clock stopt. Nothing was overthrown. There was a tremor, then a stronger shock. The movement seemed to be from northwest to southeast.

*Papoose, Trinity County* (C. Blackmore). — An electric light bulb hanging by a cord about 4 feet long was swung in an arc of about 22 inches.

*Alturas, Modoc County*. Population 500. (C. B. Towle.) — The hanging lamps in a saloon were found at 5<sup>h</sup> 20<sup>m</sup> A. M. to be swinging east and west. A tub leaning against the house on the porch was thrown down. Some men camped near the town felt a tremble of the earth. Others in camp several miles from the town were up and heard the low sound of the earthquake, but did not feel the shock.

*Susanville, Lassen County* (James Branham). — Mr. Branham was in bed with his head to the north and felt himself roll back and forth in the bed, from which he concludes that the motion was east and west. The shock was, however, not severe enough to be generally felt by people asleep.

*McArthur, Shasta County*. — Two shocks were felt, the first the stronger, the motion being east and west. Nothing was overthrown, according to a report by John McArthur.

*Stella, Shasta County* (J. F. Schilling). — A pendulum clock in the Woodward Hotel stopt.

*Redding, Shasta County* (L. ~F. Bassett). — Mr. Bassett was indoors, squatted on his toes in front of a stove lighting the fire when the shock came. He felt no tremulous motion and only one principal disturbance, which lasted several seconds. There was a slight swaying motion of the house for perhaps 10 seconds, and this was strongest at the beginning. The motion tended to throw one toward the north. No objects were overturned, but the windows rattled a little. A rumbling noise preceded and followed the shock, which he ascribed at the time to a passing train; but there was no train due at that time.

(B. Macomber.) — The shock was not intense enough at Redding to move loose objects. In a few cases clocks were stopt. The shock was felt violently and many people were awakened by it. It was preceded at a very slight interval by a roar. Up to the moment that the most violent part of the shock struck the house, I was under the impression that the sound and the vibration were both caused by a train passing. The direction seemed to be from slightly west of north to slightly east of south.

*Cottonwood, Shasta County* (J. B. Heiderick). — A clock stopt.

#### HUMBOLDT COUNTY.

*Arcata, Hwriboldt County*. Population 950. — A. S. Eakle reports that a few chimneys were damaged. Mrs. William Nixon reports that a fissure opened in one of the streets of Arcata, into which her informant, a reliable man, said he could insert his hand; but by night it had closed again. She was also informed that a brick from a chimney was thrown 40 feet toward the south. The main shock appeared to her to be east and west; two rocking chairs in different rooms, both facing east, were observed by the separate occupants to rock violently. A clock on a north wall did not stop, while many on east or west walls did. Of two clocks on the south walls of the same house, one stopt while the other did not. Mrs. Nixon [places the intensity in Arcata at VIII on the Rossi-Ford scale. She reports further that Blue Lake felt the shock to the same degree as Arcata, with falling chimneys, etc., and that shocks were felt up Mad River at Angel's Ranch and on Redwood Creek at the Berry Ranch. A later shock was felt at 1<sup>h</sup> 10<sup>m</sup> A.M., which stopt a clock on a north wall.

*Eureka, Huniboldt County*. Population 73,000. (A. S. Eakle.) — Eureka was damaged to the extent of about \$1,000, according to report. Most of the signs of destruction had been repaired, but a walk thru tin' town convinced me that the intensity of the shock

was not great. There are numerous brick buildings, but no cracks were caused in any of them. The greater number of the chimneys were unaffected. In the Public Library no books were thrown from the shelves. The large statue of Minerva on the dome of the Court-house vibrated back and forth and finally rested at an angle of about  $45^{\circ}$ . Mr. A. H. Bell, of the Weather Bureau, made a note of the direction of the movement, which was southwest to northeast, and this direction was confirmed by other observers.

(A. H. Bell, Observer U. S. Weather Bureau.)—It was the most severe earthquake of which there is any record at Eureka. It lasted 47 seconds and the vibrations were from southwest to northeast. There were no preliminary tremors, the shock being sudden and the vibrations continuous, with maximum intensity toward the end. Buildings shook to an alarming degree and several were slightly twisted. One frame building moved about 12 inches to the west. Many chimneys toppled over and several hundred panes of glass were broken. There was no loss of life and loss to property did not exceed \$8,000. Chimneys fell in all directions, but most of them toward the west. The statue of Minerva on the dome of the Court-house tipped toward the south until it leaned at an angle of  $43^{\circ}$ .

A second shock occurred on April 18 at 5<sup>h</sup> 22<sup>m</sup> A. M., and another was felt at 12<sup>h</sup> 25<sup>m</sup> p. M. These shocks were slight and of short duration. Slight shocks of earthquake also occurred in early morning of April 19; at 3<sup>h</sup> A. M. on the 20th; 6<sup>h</sup> 07<sup>m</sup> A. M. on the 23d; 10<sup>h</sup> 30<sup>m</sup> A. M. on the 27th; and at 11<sup>h</sup> 10<sup>m</sup> P. M. on the 30th. There was quite a severe shock on April 23, at 1<sup>h</sup> 10<sup>m</sup> A. M., lasting about 14 seconds. The vibrations were from southerly to northerly, being of sufficient violence to shake buildings and stop clocks in different parts of the city.

(H. H. Buhne.)—People who were not frightened and who were looking out of their windows described the scene as looking as if all the houses were on the ocean. Only one clock stopt in my house and that was the large regulator in the hall, facing southwest. The other clocks had their pendulums swung southwest, so did not stop.

The shock lasted 47 seconds. It started from a southwest direction. The reason I am so sure of it is that I was passing by my mantel, and one of the statues hit me in the back when the quake started, and it could not have come from any other direction to have done this. It kept swaying the house back and forth for a while, and then wound up with a twister. My chimneys stood it until the twister came, and that made them crack. On examination I found them turned from 0.5 to 3.5 inches. They were all twisted from southwest to north. At my hunting house the shock threw a glass globe and chimney from a large Rochester stand lamp into one of the beds, in a direction about 4 feet from southwest. If it had come from any other direction it would have smashed the glass to pieces.

The damage in Eureka, outside of the Water Works, will not go over \$10,000. Plate-glass windows were smashed in every place except the Buhne brick block. All the plate glass in this building rests on from 0.325 inch to 0.5 inch rubber. The shock picked up one building that stood on made ground and lifted it bodily 12 inches on to the next lot. This building was thrown toward the southwest. The statue of Minerva, 13 feet high and 187 feet from the ground, on the dome of the court-house, was thrown forward to an angle of  $45^{\circ}$ . She was bowing directly south. Chimneys went down everywhere, some thru the roof; others were twisted halfway round. No lives were lost and only one person was hurt by a chimney crashing thru the roof.

*South of Eureka* (H. H. Buhne).—A few days after the quake everything looked all right along the road, excepting chimneys, until I reached Field's Landing, at South Bay. Here the shock opened a fissure over 100 feet long in the middle of the road, which 6 teams spent one day in filling. Pelican Island, as it is commonly called, opposite Field's Landing, dropt 3 feet at the point where the United States pile beacon stands. It left the beacon landing at an angle of  $45^{\circ}$  from the southwest.

At Dungan's Ferry, on the north bank of the Eel River, the ground was full of fissures. Every bar on the river had been opened by fissures, and the gravel toppled over leaving big ditches, some 6 feet deep and over 500 feet long. Coming up on the mainland the road had dropt about 2 feet in one place and was full of small fissures. A 40-acre field was entirely ruined. It was heavily fissured, having dropt down in strips from 2 to 6 feet wide, from 4 to 6 feet deep, and from 5 to 500 feet long, the fissures pointing between south and southwest. All the fields were full of quicksand volcanoes, some 1 to 3 cubic yards in size. They were perfect miniature volcanoes, every one having a crater. It is said they extended 30 miles up the river.

In Ferndale not a chimney was standing and every brick building was torn to pieces. The shock threw two wooden houses sideways. All the plate-glass windows were smashed.

Near the False Cape it threw the old hill, on which the Oil Creek coast road ran, out into the ocean for 0.5 mile. It is estimated that 200 acres were thrown into the ocean. Quite a number of cattle went with the hill. The slide is said to have obscured the view of Cape Mendocino light from Trinidad heads.

In Petrolia the shock threw every house off its foundation; in the mountains it opened great fissures, ruining many acres of good grazing land. It is said that the McKee ranch, near Shelter Cove, is entirely ruined by fissures. About 6 miles below the mouth of the Mattole River, at what is called Sea Lion Gulch, the mountains pitched together, entirely obliterating this dangerous place.

The amount of damage thru the county will not exceed ,1100,000. In the forests thousands of cords of redwood limbs are strewn over the ground and many of the trees were twisted off and hurled to the earth. A friend of mine living within 200 yards of a large body of redwood at Pepperwood, near Eel River, was in the field when the shock came. It lookt to him as if the tops of the trees were almost touching the ground when they were swaying back and forth. It made him quite dizzy to watch the trees. Limbs came crashing down everywhere, intermingled with an occasional terrible crash telling of the fall of one of the giants of the woods.

*Freshwater, Humboldt County.* To the east of Eureka. Population 150. — The shock is described by Mr. S. E. Shinn as heavier than the one he experienced in San Francisco in 1868. Not a chimney was left whole in the town or valley, and glassware in houses was generally broken. The first part of the quake was from east or a little south of east to a little north of west; then came the big wave, like waves of the ocean. The orchard was lifted between 2 and 3 feet as if by a big breaker coming in. At the same time he thought the house would come down; then it seemed to give a lurch and throw the chimney straight north, some of the bricks going 15 feet from the porch. He could not keep his feet except by hanging on the door knob, after being thrown back and forth.

Alexander Coeur states that most of the chimneys in Freshwater were thrown northeast. About half of the chimneys were thrown and the rest were all more or less shattered. Some were twisted from east to west and one was turned halfway around but did not fall. The town is at the foot of a hill near a small stream, and is built on gravel having a depth of about 0 feet.

*Ferndale, Humboldt County,* Population 850. — This town, on the south side of the flood plain of the Eel River, appears to have been the most severely shaken place in Humboldt County. It is the largest town in the county south of Eureka, and is about 2.5 miles from the Eel River, as it now flows thru its flood-plain, 0.5 mile from Salt River, a tributary of the Eel, and 9 miles from the ocean where the Eel River empties therein. The valley to the north of Ferndale, and extending east and west from it, is underlain by alluvium of probably considerable depth. It is very low and subject to floods almost every winter. South of the town are rather abrupt slopes rising to the summit of the ridge which ends in Cape Mendocino. These slopes are underlain by soft sandstones of

Pliocene (Merced) age, dipping uniformly northerly toward the valley of the Eel River.<sup>1</sup>

Mr. A. W. Blackburn, of Ferndale, writing May 2, 1906, contributes the following statement regarding the effect of the shock in that town:

There is general agreement here that the principal direction of the earthquake waves was from southwest to northeast. The main street of the city runs about southwest and the tremor swayed the houses and business buildings from southwest to northeast, breaking over two-thirds of the plate glass windows facing the street, while windows on the sides of the buildings did not suffer nearly so much. One 3-story frame building was caused to lean at an angle of at least 5° from the vertical. Most of the chimneys fell, not one in ten standing, and those that did stand were rendered insecure for the most part. They generally fell either toward the southwest or northeast, where the roofs slanted in those directions. Those who claim to have been out-of-doors when the shock came state that the earth rose and fell in great waves like those of the sea.

The only two brick buildings in town, both of which were one story, with a gable in front raised above the flat roof, had these square gables thrown forward into the street. One was a new building just finished this winter, and its walls were completely ruined, being cracked and loosened. Several buildings were lifted from their foundations, but for the most part the frame buildings were simply swayed out of plumb. Accompanying the quake was a rumbling, roaring sound. The tremor was short and jerky at its point of maximum intensity.

Prof. A. S. Eakle, who visited Huraboldt County at a later date, corroborates the statements just quoted. He says:

At Ferndale the greatest amount of destruction in the county took place. According to Mr. Joseph Shaw and others of the town, the shock came from the southwest and the general direction of the fall of chimneys bears out this statement. There are 2 brick stores in the place, both of which had their upper portions thrown off. Some chimneys were thrown eastward a distance of 15 feet. Several of the frame houses were knocked out of plumb, but only one was moved entirely off its foundations, tho a slipping of a few inches was common. The main street runs northeast-southwest, and the stores on both sides had their plate glass windows demolished. (See plate 66A.) There were no cracks nor sinking of the land in the town and the damage was wholly due to the rocking of the houses. As most of the stores had large glass windows in front, the upper stories were weakly supported from lack of bracing, and this was primarily the cause of their bending out of plumb. Very few frame residences were seriously damaged. It was reported that a brick falling from the chimney of one house was thrown into the bedroom of the same house thru the upper half of one of the windows under the eaves. This illustrates the intensity of the rocking motion to which the structures were subjected.

On the flood plain of the Eel River to the north of Ferndale, Professor Eakle reports that the ground was cracked for a distance of 0.25 mile on the west bank of the river. The cracks were in close vicinity to the river, and seemed to be on the line of an old channel. A series of parallel cracks, some having a vertical displacement of 2 feet, the surface being uplifted and deprest, followed the trend of the river and were evidently local in the soft alluvium. At the time of the earthquake water and sand spouted up in several places thru openings which were in some cases 4 inches wide. Mr. Blackburn reports that this water remained on the surface of the fields for some time after the earthquake. In this same connection, Mr. J. A. Shaw reports that "a field on a high bar near the Eel River was literally shaken to pieces, and water filled with quicksand was ejected several feet high. The rents run from north and south in a curve to east and west. Some parts are actually cut into squares. The jump vertically will reach 2.5 feet. There were no such large rents thru the valley generally, as the upper soil rests on a clay foundation which seemed to stand it all right."

<sup>1</sup> For a geological section at this point see The Geomorphogeny of the Coast of Northern California, by Andrew C. Lawson. Bull. Dept. Geol., Univ. Cal., vol. 1, No. 8, p. 256.

Regarding other parts of the valley, Mr. Blackburn reports that all the other towns bordering on Eel River Valley suffered less than Ferndale. Loleta, on the northeastern edge of the valley, partly up Table Bluff, did not suffer severely. Fortuna, northeast of Ferndale, suffered less than Ferndale, tho only 6 miles distant; other towns up the Valley suffered still less. At Grizzly, population 70, 5 miles east of Ferndale, chimneys were thrown to the ground and crockery in the houses smashed, according to Mr. A. C. Matheson.

To the west of Ferndale, on the coast about 0.5 mile south of Oil Creek, a large landslide was caused by the earthquake and is described in the following note by Professor Eakle: "A section of the coast roughly estimated as one-third of a mile in length slipt on a 75° plane into the ocean, forming a point of land extending 100 yards or more into the sea. The slide destroyed a portion of the coast road which ran along the edge of the cliffs. The coast cliffs consist of Merced sandstone, dipping 45° to the north, and there is evidence that landslides have been quite frequent here in the past."

*Cape Mendocino Light Station* (R. Jensen). — The shock traveled from southeast to northwest. The light-tower and house were heavily shaken. The brick foundations and water cisterns, as well as the concrete in the yard, were broken.

*Petrolia, Humboldt County*. Population 200. (A. S. Eakle.) — Practically every house was thrown off its foundations. A moderate shock, however, could do much damage to the town, owing to its situation and the way the houses were constructed. The houses are built on the soft bottom land of the Mattole River, several of them within a few feet of the river, and their supports are simply blocks of wood, stone, or concrete resting on the surface of the ground. In the shake-up the blocks under the houses were unequally rocked and some became overturned, causing the houses to slip. The movement was in general east and west. Cracking of the land occurred along the edge of the river in close proximity to the hotel, which was quite badly damaged. Two houses on a terrace about 20 feet high, on the right bank of the river, were not injured as much as those below.

A note from Mr. Blackburn regarding this same town says that the only place which is reported to have suffered relatively more than Ferndale is the little town of Petrolia, on the Mattole River; there frame houses were moved from their foundations and even fell completely; the earth cracked very much and made wide fissures; many slides occurred and the shock was heavier. The general direction of the shock was from the southwest. The valley along the Mattole River is very narrow and the mountains are higher than near Ferndale.

From Petrolia to Shelter Cove we have the following note by Professor Eakle as to the destructive effects of the earthquake:

About 10 miles up the river at Upper Mattole, the ranch house of Mr. Roscoe was moved about 2 inches westerly and the chimney destroyed. At the town of Briceland, on the south fork of the Mattole River, the shock was severe but considerably less intense than at Petrolia. The store moved westward one inch and the stock was thrown from the shelves. Damage to the town was slight, and at Garberville, farther east, it was still less. From Briceland to Shelter Cove by stage road there are but two houses and these had their chimneys thrown off, but nothing more serious. No cracking of the land occurred except in the vicinity of the Cove. The buildings at Notley's, within 1 mile of the fault on the west side, suffered no damage. Even a terra-cotta chimney was not overthrown, altho it was knocked awry. Some of the furniture was displaced and some of the goods in the store were scattered about.

On the stage road between Eureka and Sherwood, Professor Eakle reports that the shock was sufficiently severe to throw some chimneys at the various very small settlements along the road, and that the general movement of the vibration in this section was reported to be easterly and westerly. The town of Fortuna suffered most.

*Fortuna, Humboldt County*. Population 1,100. (L. L. Thornberry.) — Many windows in stores were broken and the stocks of merchandise on the shelves were thrown down.

Drug stores suffered most in this respect, and bottles fell principally from the west side. Over half the chimneys in the town were thrown down. Several houses moved from 1 to 3 inches off their foundations. The river water swashed up on the banks. Fortuna is partly on the river bottom and partly on the hill slopes above, the Eel River being to the west of the town.

*Pepperwood, Humboldt County* (J. F. Helms). — In the stores and saloons 10 per cent of the property was destroyed by breakage, but on the farms of the neighborhood the damage was mostly confined to the throw of chimneys.

*Briceland, Humboldt County*. Population 150. (J. W. Bowden.)—The village suffered damage to the extent of \$1,500 due to the breaking of chimneys, water and gas pipes, household furniture, etc. The village is on sloping ground on the creek bottom, the latter being in solid sandstone and shale, with the bedrock near the surface generally. One 2-story building 30 x 80 feet, standing east and west on a concrete foundation, was moved north 3 inches on the west end and south 5 inches on the east end.

On the east bank of the main Eel River, to the east of Laytonville (A. S. Eakle), the ground was cracked for a distance of 300 yards, the trend of the crack following the course of the river. The crack was merely local in the alluvial bank of the stream, perhaps 100 yards from the water. A long bridge crossing the stream at this place showed no effects of the shock and the few houses in the vicinity were not damaged in the least. Further east, at Covelo, the shock was not violent.

*Thorn*. — Dishes were shaken from shelves in houses.

#### NORTHERN MENDOCINO COUNTY

BY E. S. LARSEN.

In the territory from Laytonville to Covelo, and northerly to the boundary of Trinity and Mendocino Counties, the shock was sufficiently severe to awaken nearly all sleepers, to throw milk from pans, and to jar a few things from shelves, but not severe enough to do any damage to buildings. No chimney was reported as damaged. Most of the chimneys are of rough stone, tho a few are of brick. Some plate glass was broken in one of the stores at Covelo, but the building was in course of construction and the windows were temporarily and insecurely put in place. A large proportion of the residents claim to have heard a roar just preceding the earthquake shock, and several report the shock as beginning with a slow east and west motion, and ending with quick severe jerks. A man riding in the hills at the time did not notice the shock, but his horse stumbled repeatedly without apparent cause.

There were a great many earth cracks formed in the Round Valley region. Some were examined, but many had been obscured by the winter rains, while others were not visited on account of the heavy rain which set in and made it impossible to cross the streams or get about in the hills. About 20 miles north of Covelo, about section 2, township 24 N. range 14 W., on the Horse Ranch, and about 700 feet above the north fork of the Eel River, is a crack about 40 feet across and 600 feet long. At the southeast end a ridge of massive sandstone makes that part of the terrace somewhat wider. At either end are small gullies. At the back, to the northeast, a rather steep hill of sandstone rises abruptly from the terrace. Below, to the southwest, the terrace ends in a steep slope which shows evidence of repeated sliding and has several springs near its base. There are no trees on this slope, but the hill back of the terrace is covered with trees and there are some trees on the terrace, mostly on the hill side of the crack, altho several oaks 8 inches in diameter are on the side toward the river. The main crack is about 400 feet long. It is indistinct and disconnected at the northwest end, but gradually becomes more prominent till it reaches a point just beyond the center where the river, or southwest side, is 6 inches higher than the hillside, and there is an open gap of about 8 inches. It then

begins to die out and upon reaching the sandstone ridge turns about the edge of the ridge and continues about 100 feet more in the shape of irregular cracks along the ridge.

The rocks about this crack are probably all Franciscan. The sandstone extends for some distance in all directions and is usually shown only by fragments. Cherts, serpentines, and schists occur a short distance above and seem to be closely associated with the sandstones. The strike seems to be northwest and the dip quite steep to the northeast. No evidence of faulting was found, but the few outcrops showed little structure. The hills for a considerable distance on all sides of this crack are covered with old slides. Careful examination and enquiry revealed no extension of the crack in either direction.

The extension should pass fairly close to the road from Covelo, but none of the ranchers along the road knew of any cracks in the hills until Dobbins' place was reached, 10 miles southwest, on section 14, township 23 N., range 13 W. Here a crack 600 feet long, trending N. 25° W., occurs on a bench 150 feet wide, made up of soft alluvium gravel, etc., bounded on the northeast by a steep hill of serpentine; on the southwest by a steep slope to the creek 200 feet below, and on the northwest and southeast by bedrock ridges. The crack occurs near the outer edge of the bench and the creek (southwest) side is a few inches higher than the hill side. It does not continue into the hard rocks at either end. Between the creek and the hill the ground is soft, miry, and full of springs, while at the edge of the hill irregular cracks are sometimes seen, showing that the muddy flat had likewise settled relative to the hill and indicating that the soft central area had settled relative to the hard, dry slope toward the creek and the bedrock of the hill. The crack runs under the cabin where there was the greatest movement, but tho the cabin is on four pegs, it was not disturbed.

In the absence of a map it may be stated that this crack lines up very well with the one mentioned above and that the upthrow (?) is on the southeast in both cases. Both are in soft material and both are parallel to the streams. Moreover, the road and a majority of the ranch houses are roughly in this line, and cracks off this line would be more likely to escape detection. No cracks were found between Dobbins and Covelo. Several cracks were reported crossing the road from Covelo to Laytonville near the top of the hill to the north of Middle Eel River. They are said to continue at irregular intervals for a mile or more to the north or slightly north of west. They generally trend north to northwest, but vary considerably.

One mile farther west toward the Eel River, a crack cross the rdad toward the north. There is a strip of soft sandstones and shales thru here resembling that found at the Horse Ranch and striking to the northwest. In this strip numerous cracks were found, often trending northwest but varying considerably. Four of these cracks were visible, but others could not be found as the rains had healed them. It was said that the downhill or southwest side was sometimes higher than the northeast side. Only one of these cracks could be ascribed to a slide. The other three might very well have been due to the shock. Just north of W. Geforth's house is a crack 1,000 feet long, trending N. 55° E., and following roughly a low ridge running out from the main hills. It cuts almost at right angles to the main hills and is in soft material which has little slope. It could hardly be an ordinary slide.

On the top of the ridge, where the soft streak crosses the hills at an elevation of about 1,000 feet above the river, is a crack about 50 feet long just below a low sandstone knob, trending northwest partly across the draw at a considerable angle with the crest of the hills. It is irregular and shows no displacement of any kind. It could hardly be a slide.

Still farther north, just beyond E. Gevire's house and about 5 miles from Robbins, is another crack trending northeast. It is probably a slide. Mr. Gevire stated that there were several slides in the hills on all sides of his house, but no other cracks were reported to the north. To the south the cracks extended to the river, but none were known south of the river.



About a mile farther west, at Poon Kenney, several more short cracks were reported trending northerly but varying in direction, and not connecting along their trend, but I could not find any of these. About 6 miles north of the bridge on the Eel River, at a sheep camp called Hole-in-the-Ground, there are said to be a great many cracks running in various directions, but I did not visit them. On the whole, I believe that these cracks were all due to the earthquake, but that they are nothing more than surface cracks due to the jar. They occur only in the soft strips of weathered sandstone and where they seem to be related in trend they also seem to follow the strike of the rocks.

#### SHELTER COVE TO ALDER CREEK.

The intensity of the earthquake shock near the coast of Mendocino County, between Shelter Cove and the mouth of Alder Creek, is of peculiar interest, since along this portion of the coast the fault line is offshore at an unknown distance and has an unknown course, except in so far as can be indirectly inferred. One of the most important factors in the problem of determining the probable distance offshore at which the fault line traverses the floor of the Pacific is the intensity of the shock as experienced at points along the coast. Fortunately we have satisfactory information on this point.

*Monroe, Mendocino County* (D. Besecker). — About 90 per cent of all brick chimneys were thrown down. In houses with shelves and cupboards arranged east and west, 50 per cent of all dishes and glassware was broken. Stores with shelving running the same way had all goods thrown off the shelves. Many buildings of light frame construction were moved from their foundations. This place is in the heart of the great redwood forests, where trees attain a height of 300 feet or more. These tall trees suffered more from broken tops than anything else; few if any sound trees were entirely uprooted. The trees swayed to and fro for fully 10 minutes after the shock. The direction of the motion was north and south. Fissures opened in the mountain sides, and during the present winter (March, 1907) many large landslides have resulted from these openings.

*Hardy* (Alice Kingsbury). — My chimney was thrown down. Many dishes in surrounding houses were broken. My piano was moved 8 inches from the wall. The earth was cracked, both upon the mountains and near the creek, where the earth was broken away from the banks. The logging railway in the woods was somewhat damaged. The walls around the boilers in the lumber mill were cracked.

*WeMport* (M. M. Bates). — All but one of the chimneys in town were shaken down. Large tanks that were on the ground were destroyed, but those built on framework were not damaged. Large cracks were made in the ground, and after the heavy rains of this winter (March, 1907), large landslides occurred. Goods were thrown off shelves in the store. (The town is quite near the ocean on a wave-cut terrace underlain by rock.)

*Inglenook, Mendocino County* (E. Pitts). — Not a chimney was left standing, nor were dishes enough left to eat breakfast on. The town is between the ocean and a belt of timber. Much of the timber fell, owing to the violence of the shock. On the banks of a small lake in the sandhills h'tween the town and the ocean, some alders and willows fell owing to a plumping; of the banks.

*Vletme, Mmdirino County*. — Most of the chimneys in the place are terra-cotta. All the brick ones fell. About \$1000 worth of breakable goods in a general merchandise store was totally destroyed, and about \$300 to \$400 damage was done to the wharf and railroad tracks. All sway-braces on the wharf had to be replaced, and the railroad track was buckled in many places. The bridge across the lagoon sank 3 feet in some places, and was thrown out of line laterally, all the piling supporting the bridge being tilted to the right.

*Trinity, Mendocino County* (J. M. Branscorab). — Of about 15 chimneys in the town, 2 were shaken down.

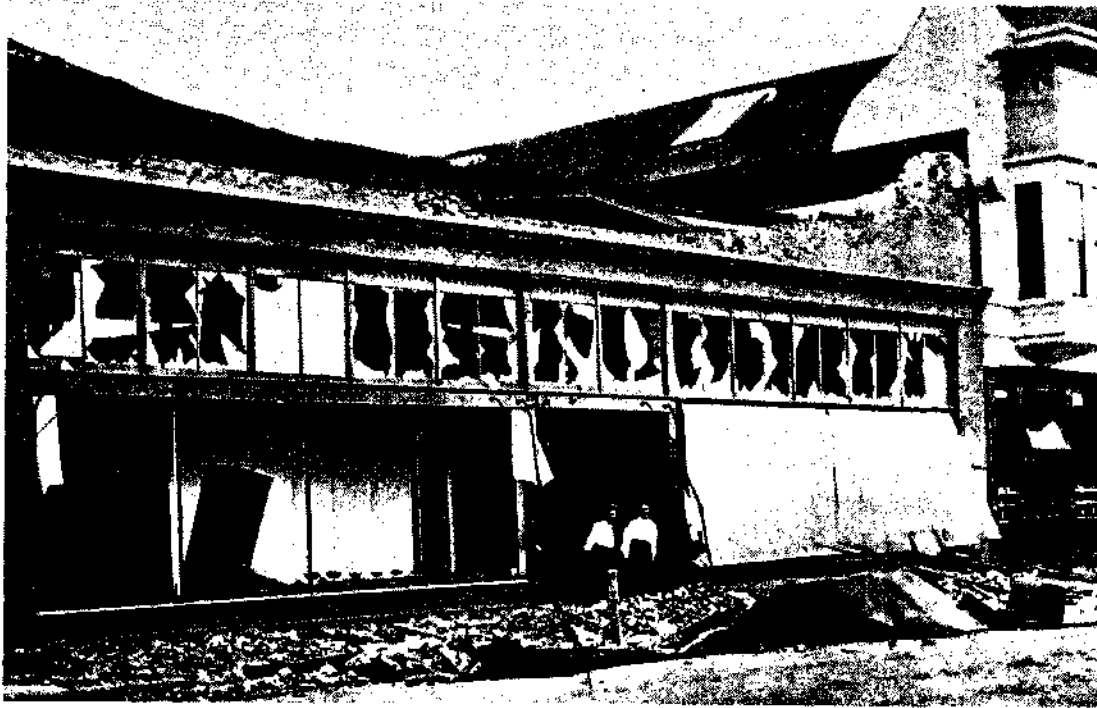

A. Wreoked Btores, Femdale, Enmloldt County.



B. Wreoked buildingSi Fort Bragg. Looking northwest!



A. Odd Fellows' Hall, a 3-story brick building Fort Bragg. Looking east

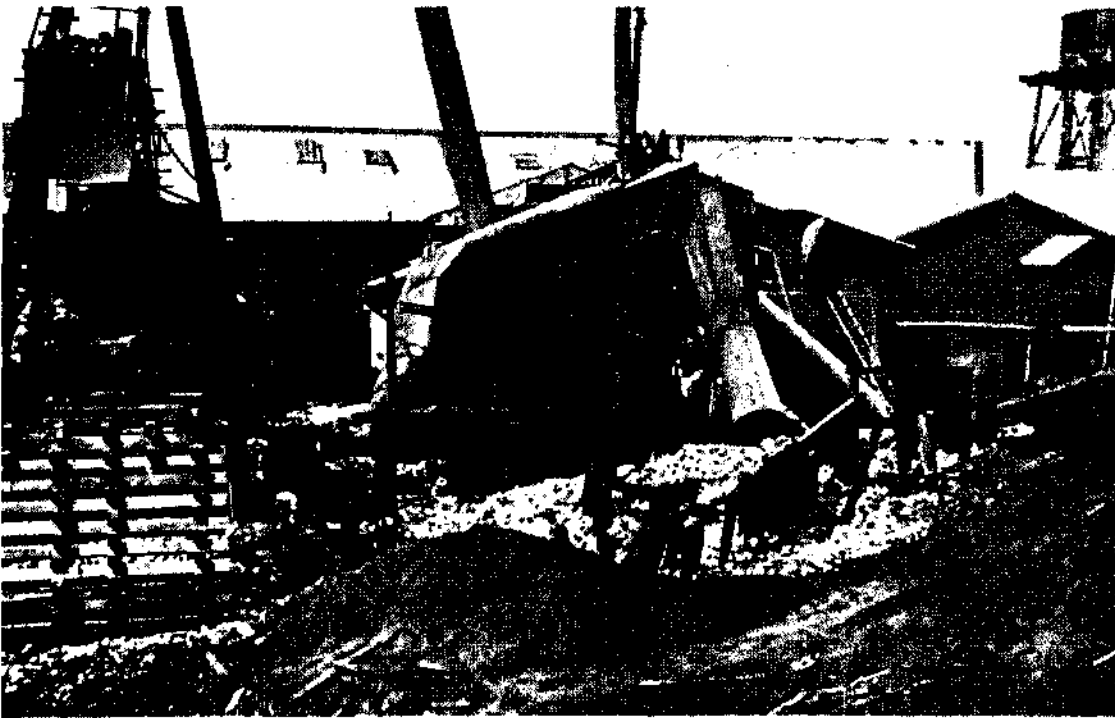

B. U. O. O.'s mill, Fort Bragg. Smoke stack 5 feet in diameter. Entire structure tilted out of plumb to south, 1 foot in 20 feet.

*Fort Bragg, Mendocino County.* Population 1,600. (F. E. Matthes.)—The town of Fort Bragg suffered quite severely, and the indications are that the intensity of the shock was considerably greater than in the towns immediately to the south. Several brick buildings were completely demolished; others had parts of their walls broken off. Even a number of wooden buildings collapsed or were partly wrecked. Fire broke out and devastated 1-| blocks before it could be controlled. The water mains were disconnected and the entire town might have been wiped out but for the timely assistance of the steamer *Higgins* in the harbor. The mill lost its iron smoke-stack, and was temporarily crippled. In all, the damage thru fire and earthquake is estimated at \$100,000. (See plates 66B and 67A, B.)

The following more detailed account of the effects of the shock at Fort Bragg is supplied by Mr. O. F. Barth, principal of the Fort Bragg Union High School:

The first shock had an oscillatory motion. A temblor was felt about 2 hours later, and from 1 to 3 temblors have been felt at irregular intervals nearly every day since.

The direction of the wave of the heavy shock appears to have been toward north by east. The principal fact that justifies this statement is that the monuments in the cemetery, with but two exceptions, fell from their bases south by west. A second reason is that a cylinder printing press weighing not less than 5 tons moved about 3 inches south and 2 inches west upon a level floor. The part of the building containing the press has been finished only a few months, has a strong wooden beam foundation, and was not moved out of position. About a block away a safe in such a position that it could not move in the direction of its rollers, north to south or the opposite, was thrown off its blocks westward 3 or 4 inches. At the high-school building (temporary quarters, not moved at all), a large case about 2 x 4 x 7 feet, full of apparatus and instruments used in physics, moved (rolled out) toward south by west, but nothing was upset within. This case stood close to a central partition on the north side of a south room on the second floor. Chemicals on open case shelving on the outside (south) wall of said room were nearly all thrown to the floor.

At Noyo, 1.5 miles from the center of Fort Bragg, a store 1-story high, having but a floor space of several rooms, perhaps 50 x 60 feet, on underpinning averaging 3 feet high, moved about 22 inches west and nearly as much south. This store stands within 100 feet of the Noyo River. At Fort Bragg most chimneys were broken off at the roof and most of them fell southward, but in a few cases they scattered around the shaft. Those built up from the ground, as a rule, fared worse. The large smoke stack at the saw-mill fell south by west. The brick foundation of a battery of boilers placed north and south was shaken down; another battery close by, facing east and west, was not affected. A large engine with a well-built brick base did not move, nor did the base, nor did the latter crack.

In my house and in several others, dishes on east shelves fell to the floor, while those on shelves on the other sides were less affected, those on the south hardly at all. The south shelves of two jewelry stores fared differently, all the small alarm and other light clocks falling out. In a drug store, one block north of said jewelry store, the north and east shelves suffered most, the north the more; but this may have been due to the difference in the bottles and packages, and to the additional jar of a falling brick building.

Several 2-story wooden store buildings facing west were thrown to an angle southward, the base remaining on the foundation, and the second floor moving from 0 to 20 or more inches. The upper story in most of these remained plumb. Eight brick buildings were shaken to the ground; two are being taken down. A new brick 1-story bank building is badly cracked, and only one brick building, 1-story, is intact. Of the eight, three were 2-story buildings. Many residences were moved, a few as much as 20 inches. Both 1-story and 2-story square built wooden buildings held their own well, except for their chimneys. The four wooden church buildings facing west, and the one facing south, are intact, save chimneys.

One man walking on the street was thrown down. He is positive the wave traveled southwest, the ground undulations being 2 and 3 feet high. Another looked out of his door toward town, facing southwest. He says the wave traveled in that direction and a roar accompanied it, appearing to go farther that way each second.

At the cemetery, one four-piece monument dropt its top piece to the north by east, **and** the next two pieces as in other cases. The flat or ordinary grave-stones facing east are all intact.

In the press-room referred to, a bond fire extinguisher was apparently thrown or whirled from a southeast corner shelf out near the center of the room, and right side up. This would bear out the idea of a twist or double movement contraclockwise, apparently experienced by several people, myself included.

There are a number of fissures in the mud flats in and near the Noyo River and Puddin Creek. The boys say there are cracks in the streams. There are cracks in the less solid rocks along the ocean shore line.

(Eri Higgins.)—My house faces west. The east part was moved 6 inches south, breaking water and sewer connections. The west end of the house did not move. Goods on shelves were thrown from the north side, but not from the south side. All brick buildings in town went down except two, and these were damaged.

The above facts indicate that the destructive effects were as severe at Fort Bragg as at any other point within the zone of high intensities, but it is necessary to know something of the situation of the town. Experience elsewhere in the zone of destructive effects has shown that much damage may be caused to buildings even at considerable distance from the *locus* of disturbance, if they are upon soft alluvial bottoms. An inquiry was accordingly directed to Mr. Barth as to the situation of the town and its underlying formations. In response to this inquiry, Mr. Barth replies as follows:

Fort Bragg is mostly on the first terrace. The bluffs rise about 40 to 50 feet above the sea. Then the terrace has a gentle slope thru the town up to the second terrace (a rise of 60 to 75 feet above cliffs), which begins about where the built-up part ends. There is no distinct line of division, but a more rapid rise for a few hundred feet marks the second terrace. It is about 0.25 mile on an average from the bluffs to where the town really begins, *i.e.* going eastward; and the town has a width of a little more than 0.25 mile, from here to the second terrace, still going eastward. The sea-cliffs are rough, rocky, perpendicular walls, or nearly that, for several miles, with many bold, rocky, tooth-like sea-worn isles skirting them.

About half a mile north of town, Puddin Creek, and about a mile south of town the Noyo River, have cut their way thru rather deep canyons to the sea. While the volume of water in the latter is larger, the narrow valleys of the two do not differ much. Narrow strips of tillable land skirt them. The two almost meet about 3 miles east of the bluffs, where there is a narrow divide and where the third terrace appears to begin. There is a gradual rise from the second to the third terrace.

The surface soil upon which Fort Bragg is built consists of a sandy loam, rather sandy and yet pretty firm. The laying of sewer pipes 4 to 6 feet deep reveals more sand below, of a dark yellow color. At the bluffs or cliffs there is from 10 to 15 feet of soil. At one point where the second terrace begins (here Puddin Creek curves in close to town), solid rock comes close to the surface.

A well about 500 or 600 feet north of the business center reached rock at 30 feet. One of the brick buildings, a 3-story hotel which was so badly injured that it had to be taken down, stood about 100 feet from this well. Another well, 0.25 mile north of the business center, obtained water in sand at a depth of 22 feet without reaching rock.

The town is comparatively level from north to south, except for a small valley — hardly that — a 0.25 mile wide vale, running down thru the mill yards to the sea at the point where the harbor indents the coast.

It is clear from this description that the town of Fort Bragg is on a well-defined wave-cut terrace carved out of the hard sandstones which prevail along this part of the coast, and that the terrace is mantled with Quaternary marine sands varying in thickness from 10 or 15 feet at the brink of the present sea-cliffs to 30 feet in other parts, and tapering to nothing at the rear of the terrace. It therefore seems to be a fair inference that the destruction experienced at Fort Bragg is not due, except to a very limited extent, to those causes which work exceptional damage in the water-saturated alluvial bottoms; but that it is referable to the high intensity of the shock, thereby implying proximity of the town to the fault.

(W. T. Fitch.)—There were several small cracks across the roads a few miles south of Fort Bragg; and back in the hills there were more and larger ones. In the bed of the Ten-Mile River, 10 miles north of Fort Bragg, where level surfaces occurred before,

there were noted after the earthquake funnel-shaped depressions resembling extinct volcanoes in miniature. These were only a few feet in diameter.

At Glenblair, 5 miles east of Fort Bragg, the intensity of the shock appears to have greatly diminished. The place is on a creek bank, between high hills. Mr. A. P. Scott reports that the saw mill was slightly damaged and that the store goods were thrown from north and south walls.

*Caspar, Mendocino County.* Population 300. (F. E. Matthes.) — The shock was apparently not so severe. Most of the wooden houses showed no damage. Even the large brick store of the lumber company appeared little affected. It was probably well built and sustained only a few cracks of little importance. All chimneys were broken without exception. The bridge over Caspar River is a total wreck, but it appears to have been a weak structure to begin with.

*Mendocino, Mendocino County.* Population 900. (F. E. Matthes.) — This town, like Fort Bragg, is on the first of a series of wave-cut terraces which score the coastal slope. The present sea-cliffs at the lower margin of this terrace vary from 30 to 100 feet in height. The terrace is veneered with Quaternary marine sands which are in part so compacted and coherent that they may be designated sandstones. The town shows but little damage. Only one large frame building, the Occidental Hotel, was wrecked thru the giving way of its underpinning. Few chimneys escaped destruction. Plaster fell in quantities in some dwellings, while others suffered but little in this respect. Only one out of a considerable number of water-tanks was wrecked. In the river bottom adjoining the town the destructive effect was notably greater. The lumber mill of the Mendocino Lumber Company was the chief sufferer. It lost its tall smokestack, and in addition had its large fly-wheel in the engine-room broken by the shock. This fly-wheel was oriented almost east and west on a north and south axis. According to the engineer, it was not in motion at the time of the quake. The oscillations of its exceedingly heavy rim caused the fracturing of the spokes in the two upper quadrants. The fragments were still visible in the mill yard.

The bridge over the Big River was also severely damaged, a short span in the long approach on the north side collapsing entirely. The structure had been repaired at the time of the visit.

(O. H. Ritter.)—Vibrations at Mendocino seemed to be oscillatory, moving north and south. I remember the feeling clearly, for my bed extends north and south, and moved in a straight line north. The high-school building was moved on its foundations about 2 inches north, and a 3,000-pound safe in town rolled north 3 to 4 inches. The wing of Occidental Hotel which extends east and west collapsed; while the wing extending north and south remained standing, altho the foundation braces were thrown slightly out of plumb in a north and south direction. It is very clear here that the vibrations were north and south. The day after the shock there were numerous cracks in the ground. Chimneys seem to have fallen north and south, generally south; numerous slides on the cliffs took place, some very large. The road between Point Arena and Mendocino was cut off by numerous slides (report of tourist). The bridge across Big River, extending north and south, collapsed. The fall of the span was due to the shifting north of the piles on the north side of the river, thus allowing one end to drop.

(William Mullen.)—The shock at Mendocino began with a tremulous motion, increasing very quickly and decreasing also quickly. The principal disturbance was strongest toward the end. The motion seemed to be up and down, and also from north to south. Chimneys fell mostly to the north, while tombstones fell to the north, south, and east. It lasted about 40 seconds. Beds were moved from 3 to 5 feet and pianos to the same extent. Pictures hanging on walls showed marks of having swung 8 inches. A rumbling sound like distant thunder preceded the shake, and was loud-s\* d the commencement of

the movement. During the shake animals became greatly excited; horses and cattle ran about. Water in some wells became muddy and frothy.

*Navarro, Mendocino County* (F. E. Matthes).—This town is an abandoned one, and the conspicuousness of its damage may perhaps in large measure be attributed to the neglected state of its buildings. Nearly every house, except for the few still occupied, suffered partial collapse of its underpinning, so that from whatever point the town be viewed, it presents the same remarkable jumble of -leaning, half-ruined houses. Its location on the flat, alluvial bottom next the river probably contributed to the severity of the damage. In fact, of the entire series of villages and towns visited on this section of the coast, this is the only one that stands on alluvial ground; all the others are built on firm rock terraces. The great wooden bridge at Navarro showed no damage whatever.

*Greenwood, Mendocino County* (F. E. Matthes).—Weak underpinning caused the partial collapse of several frame houses. Chimneys had fallen without exception. Plaster fell in the lower stories of the few houses containing plaster. The lumber mill was not damaged. Windows were broken in the hotel. If the fault line be produced northward with the last bearing observed, N. 28° W., it will be found to pass about 2.5 miles to the west of Greenwood; that is, nearly the same distance which separates Point Arena (*i.e.* the town of that name) from the fault. Yet the destructive force seems to have been a little less effective here than at Point Arena.

*Albion and Little River, Mendocino County*.—These two small settlements to the north of Navarro are compared by Mr. Matthes with Greenwood. He states that the damage at Albion was on a par with that at Greenwood. Only a few of the weaker wooden houses were crippled by the partial collapse of their underpinning. The bridge suffered but little damage. At Little River the intensity of the shock seems to have been less than at Albion or Greenwood.

Mr. James Coyle, of Albion, reports that he was on a hillside at an altitude of about 500 feet. He heard a roaring noise similar to a heavy fall of hail coming from the ocean to the west. The earth shook back and forth. He was thrown violently to the ground, as were also several cattle and horses that were grazing near. Large rocks were seemingly squeezed out of the hillside and rolled into the river. The trees were shaken northwest and southeast. He noticed only one maximum of intensity. Many houses and bridges were thrown down, chimneys all fell, and large landslides blocked the roads.

*Bridgeport, Mendocino County*.—An extensive landslide came down into the cultivated fields on the flat, wave-cut terrace east of the road.

#### ALDER CREEK TO FORT ROSS.

*Manchester, Mendocino County*.—Population 75. Nearly all the information that we have regarding the intensity of the earthquake shock for the coastal strip between the mouth of Alder Creek, where the fault enters the shore from the Pacific, and the point near Fort Ross, where it again leaves the shore, is contained in a report by Mr. F. E. Matthes. This is, however, supplemented by notes by Mr. W. W. Fairbanks, of Point Arena, for the phenomena observed in the vicinity of that town and by other observers in the vicinity of Fort Ross. In the following pages the statements regarding this territory will be understood to be extracts from Mr. Matthes' report, unless otherwise stated:

Manchester, a small settlement with a population of less than 100, only three-quarters of a mile west of the fault, was severely shaken, yet none of the frame houses in the village itself was badly damaged. A number of them slipt on their foundations, a notable case being that of W. W. Fairbanks' dwelling, which was twisted off its concrete supports, so that one of its corners was found 4 feet from its original place. The rotation was right handed. East of Manchester several farms were visited which were directly on the line



A. Point Arena. Brick house destroyed j wooden houses little affected. P. E. H.

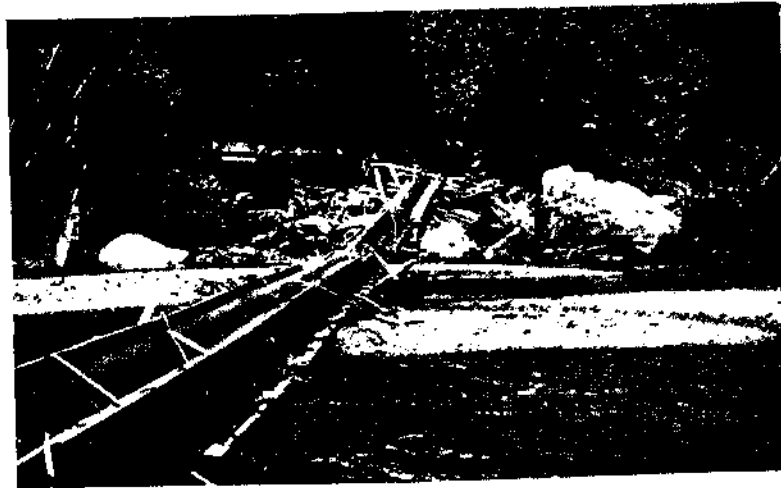

B. Wreck of suspended trestle across Garcia River. Looking west. F. E. M.

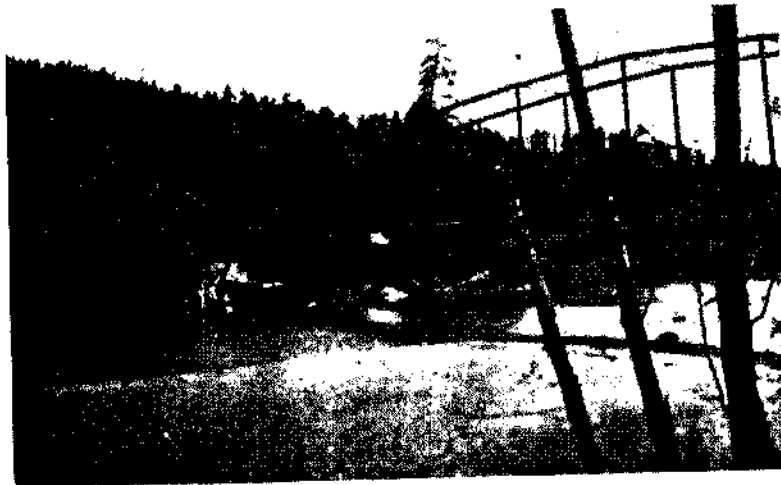

C. Collapsed wagon bridge over Gualala River. Built to draft 20 feet. F. E. M.





A. Sound redwood tree snapt off 42 feet from top. Near Port Boss. F. E. M.



B. Eedwood tree snapt off. Locality, 0.25 mile east of fault above Fort Eoas. F. B. M.



C. Uprooted tree, 8 feet in diameter, 187 feet long, about half mile west of Garcia Eirer, OH road to Garcia Mill. Taken in 1904. F. E. M.



D. Bridge over South Fork, Qmlala River, 3 miles east of Stewart's Point, looking north. Bridge floor and panels made of heavy timbers. P. E. M.

of the fault. A large barn at E. E. Fitch's ranch, thru which the fault past, was practically demolished. The animals in the barn fortunately escaped uninjured.

At Antrim's ranch, on Alder Creek, a tall shed stands on the line. It threatens to fall, but was still up at the time of the visit (May 10, 1906).

The wagon bridge over Alder Creek (plate 32B), which stood astride of the fault, is a complete wreck. The timbers broke in many places, and the tension rods were twisted and in some cases actually ruptured.

Along the Garcia River, the flumes of the L. E. White Lumber Company were reduced to kindling over long distances. Where they cross the river, suspended from steel cables, the end supports of the latter failed and let the flume drop down to the river-bed.

Farther up, between the lumber camp and Hutton's ranch, extensive landslides occurred, chiefly on the east side, wiping out the wagon road which was graded along the mountain slopes. Immediately north of Hutton's ranch, a large landslide plowed into a grain field, producing a series of billowy wrinkles in the soft alluvial material. The outermost ridge has a steep front about 8 feet high and seems to have been thrust horizontally over the level surface of the field. The frontage of the slide is fully 400 feet. Hutton's ranch-houses were all so badly damaged as to become uninhabitable; they are practically wrecked, tho still standing.

Reports from Hot Springs, east of the Garcia, seem to indicate that the buildings there suffered but slight damage. The springs themselves had not been affected by the shock.

From Alder Creek to Irish Gulch, and for a short distance north, rock slides are a common feature and cracks in the ground, frequently traversing the stage road, due to the slipping and settling of large masses on the steep hillsides, are too numerous to be reported in detail. On both sides of Irish Gulch the road was obstructed by slides which had been removed at the time of the visit, but which threatened to recur.

Reviewing his observations as to the intensity between Fort Bragg and Manchester, Mr. Matthes concludes as follows:

The gradual decrease of the intensity as one travels northward from Manchester is to be expected, in view of the gradually increasing distances of the several settlements from the line of the fault (it being supposed that the latter continues with the bearing measured near Alder Creek, N. 28° W.). On this supposition the decrease in intensity should, if anything, become more marked from Mendocino on; but such is evidently not the case. While the intensity does not materially differ at Caspar, it notably increases toward Fort Bragg; so much so, indeed, as to suggest a gradual curving of the fault, roughly parallel with that section of the coast. It is to be noted that over the distance between Fort Ross and Manchester, some 4 miles, the azimuth of the fault-line decreases steadily from N. 46° W. to N. 28° W. This gives a total deflection of 18° in 48 miles. Assuming that the curvature continues northward at a uniform rate, there will be in the latitude of Fort Bragg, 35 miles farther north, a further decrease of the azimuth of nearly 13°. The fault, therefore, may bear only N. 15° W. in that neighborhood. Plotted on a map, the line with such a curvature appears to pass 5 miles west of Fort Bragg.

*Point Arena, Mendocino County.* — Population 300. All the brick buildings in the place had completely collapsed (see plate 68A), and in the opinion of the residents it was deemed wisest to replace them by frame structures. AH brick chimneys had fallen; plaster had cracked and fallen wholesale fashion, especially on the lower floors, and many shop windows and smaller panes were broken. A few wooden buildings suffered from the collapse of their underpinning. As a result of the shock, fire started in the chemical laboratory of the grammar school, and that building, together with the Methodist Church adjoining it, burnt down.

The Point Arena light-house, 3 miles west of the fault, was thrown out of the vertical, and in addition sustained several horizontal cracks thru its masonry. It has been condemned as unsafe and is to be torn down. The keeper's dwelling suffered little damage, one chimney showing cracks, the other appearing intact. The fog signal was not damaged. On the south side of Point Arena harbor, large masses of rock slid down to the beach. Small rock slides took place all along the coast in this neighborhood. A suspended flume over the Garcia River was wrecked (plate 68B) and large trees were overthrown (plate 69c).

This account by Mr. Matthes of the effects of the earthquake in the vicinity of Point Arena is supplemented by the following, account of the destruction effected in the same territory by Mr. W. W. Fairbanks, who was on the ground at the time of the shock. His note covers the section of country from Alder Creek on the north to the town of Point Arena on the south, a distance of 7 miles, and from the coast eastward 1.5 to 2 miles. The note is dated May 5, 1906.

The country described is low and flat, sloping gradually to sea. The coast from the mouth of Garcia River north to Alder Creek is low and flat, with sand-dunes. South of the Garcia, high and rocky bluffs occur, except at Point Arena Harbor, which is at the mouth of a gulch running east to the mountains, the town of Point Arena being on the northern slope and bottom of gulch. Three creek bottoms are embraced in this territory, with higher ground between, somewhat rolling and with outcroppings of rocky ledges underlying.

Nearly every house in the territory described was injured, wracked, or moved more or less. The interior damage was severe. Stoves were thrown down and smashed into fragments. Nearly all chimneys were thrown to the east. Many wind-mill tanks were thrown down, those not containing water generally escaping. All church steeples stand intact, tho in some cases separated from the buildings. All old and flimsy buildings, barns, etc., escaped with least damage, many showing no injury or movement. Strong and stiff frame buildings suffered most. All brick buildings in the territory were thrown flat to the ground, except the government dwelling and light-house at Point Arena. Many frame buildings in Point Arena were utterly demolished. Buildings on or near rocky ledges, or buildings upon high ground with underlying rock formation, suffered the least; buildings on soft ground or creek-bottoms suffered most severely.

The shock came from a southeasterly direction. A heavy roaring sound preceded the shock. The ground moved in undulating swells or waves, rising and falling. Men and animals — horses, cows, etc. — were thrown to the ground, and were unable to rise or stand during the shock.

A great crack or fissure in the earth, starting from the sea-coast at the mouth of Alder Creek and extending in a direct line about southeast by south, termination unknown, past under the large wood and iron bridge over Alder Creek, throwing it into kindling wood. It past under the corner of the barn on Antrim's ranch, wrecking same. It then past thru a potato field, and a large section of same sank about 4 feet. Farther on, it past under a water pond and the pond went dry, tho the water returned in a few days. It past under another barn, a large frame building, and utterly demolished it. All the section of country on the westerly side of the crack moved northwest about 8 feet. Buildings on the east side and near the crack suffered but little; in fact, the section west of the crack received practically all the damage. The crack was about 4 feet wide in places, and the ground was thrown up in a great ridge, as by a gigantic plow.

In Manchester nearly every house was thrown west from 1 to 20 inches. There was one exception, however. A strong new frame house, 2-story, was thrown from its concrete foundations, the rear end swinging to the north and east 5 feet, the northwest corner acting as a pivot and remaining on its foundation pier. The house is built on soft ground near the creek bottom, with quicksand formation underlying. The woodshed and other outbuildings on same lot were thrown and swung in the same direction, but in less degree. Another house, 0.5 mile due east, on the same creek-bottom, swung to east and north, showing the same circular motion, tho moving but a few inches.

Point Arena light-house, erected 1870, a brick tower 110 feet high on a high, rocky point, is still standing but dismantled and condemned. It was broken clear thru in sections, as shown in fig. 49. It leans slightly to the north. The keeper on watch in the tower says: "A heavy blow first struck the tower from the south. The blow came quick and heavy, accompanied by a heavy report. The tower quivered for a few seconds, went far over to the north, came back, and then swung north again, repeating this several times. Immediately after came rapid and violent vibrations, rending the tower apart, the sections grinding and grating upon each other; while the lenses, reflectors, etc., in the lantern were shaken from their settings and fell in a shower upon the iron floor."

Iron rods, supports, railings, and brackets were bent, broken, twisted, and thrown from their positions, making the wreck complete. The dwelling-house, a strong brick structure 50 feet distant, is badly cracked. Chimneys were not thrown, but one on the north was badly broken. The fog signal, 50 feet west of the tower, a wooden building containing heavy

machinery — steam-engines, etc. — was not affected in the least. A high wind-mill and water-tank, 0.25 mile southeast, were unaffected. I am convinced that the shock was comparatively slight here, owing to the solid rock formation underlying. Had it been as severe as at Manchester (3 miles distant), or Point Arena (4 miles distant), both tower and dwelling would have been thrown into ruins.

In Point Arena all brick buildings were thrown to the ground. Main Street runs north and south; all stores and business buildings (wood) on the east side of the street remained comparatively stationary, but all windows facing west in same were smashed, even the sash being thrown into fragments. Interior damage was great. Buildings on the opposite (west) side of the street and facing east suffered no breakage of windows, but nearly all moved west from a few inches to 2 feet. All chimneys were thrown east.

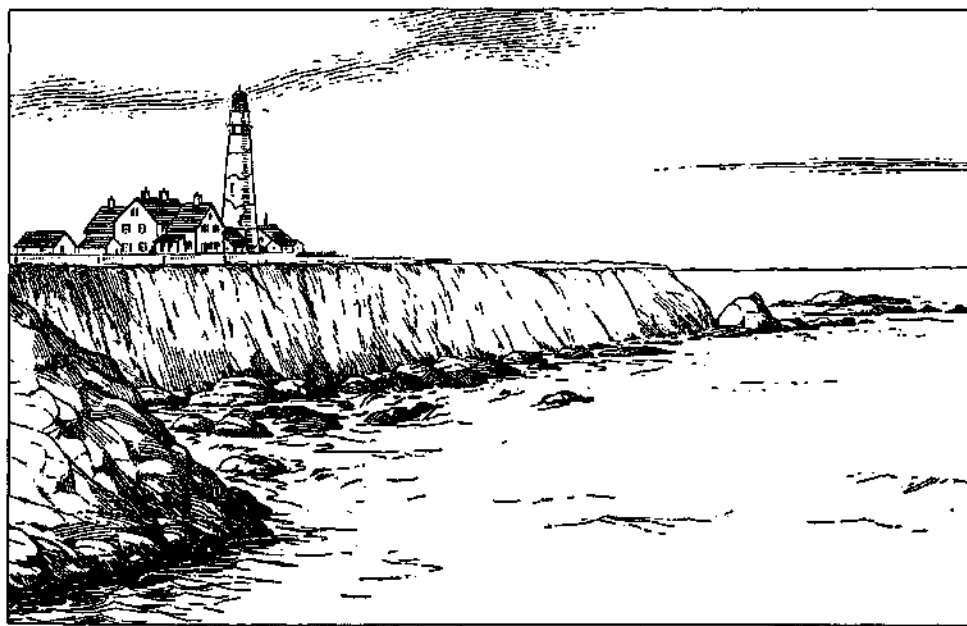

FIG. 49. — Crauks in lighthouse tower, Point Arena.

Buildings lower down on the slope as a rule suffered more, tho several wooden buildings high up, with underlying rock formations, were also wrecked. Nearly all buildings thruout the town moved west or northwest. In many cases houses drifted away and left porches standing in their old location. On the creek-bottoms many small cracks or fissures appear, thru which fine slate-colored sand has been forced to the surface, forming cones.

Between Point Arena and Gualala there are few dwellings and little of a definite nature could be ascertained by Mr. Matthes in his examination of that section.

At Fishrock, population 75, Mr. James F. McNamee estimates the damage at \$1,000. The town is on a terrace of the coast 150 feet above sea-level on rocky ground.

*Gualala, Mmdotino County.* — The wagon bridge over the Gualala River, south of the town, was seriously damaged. It consists of a trussed three-span structure 500 feet long, with a wooden approach of similar length built on trestles 20 feet high thru the swampy bottom-lands on the south side. This approach collapsed completely, the trestles being thrown flat and carrying with them the south end of the main span. The latter, however, did not leave its northern abutments and appears otherwise undamaged. It is considered safe to travel over, altho the bridge floor is now steeply inclined to the south. (See plate 68c.) In the town, population 75, all chimneys broke off; plaster cracked in the hotel and several other buildings; a few small dwellings were thrown off their underpinnings. Household articles and furniture suffered severely, most of the crockery and glassware in the town being destroyed.

A number of landslides blocked the wagon road and railroad track north of the river. A particularly extensive one occurred north of the junction of the branches of the Gualala, burying the tracks under many tons of rock and loose debris.

The railroad tracks of an abandoned logging road west of the Little North Fork show the effects of intensive longitudinal compression. The fault itself was 100 feet east of and parallel to the track along the stream bed, yet the rails have in several places been jammed lengthwise with sufficient force to cause sharp buckling. Stumps and cliffs on both sides of the track prevented the wholesale lateral sliding of the ties and localized the motion to a shifting of the ties a few feet lengthwise here and there. The kinks were so sharp as to cause the rupture of both rails in one place, and of the fish-plates joining the rail-ends in another. The track was narrow gage, with light rails, probably not exceeding 30 lbs. to the yard. In all 6 sharp kinks were counted within a distance of about 300 feet. (See plates 33c, D.)

*Annapolis, Sonoma County* (G. W. Fiscus).—Buildings were destroyed and bridges wrecked in this neighborhood; landslides occurred and the waters of the Gualala River were thrown out 50 and 60 feet on a gravel bar. The river rose 12 or 14 inches in a few hours after the shock. The motion was from southwest to northeast. It started like a wave and then assumed a rotary motion, tearing and grinding. The formations underlying the ranch are said by Mr. Fiscus to be hard-packed sand below the surface soil to a depth of 20 feet, then solid hard rock, as shown in a well 35 feet deep. In this well the earthquake broke out chunks of rock on opposite sides from within 10 feet of the top clear to the bottom. The line connecting the displaced rock on the two sides has a bearing of S. 30° W.

In several places along the line of the fault fissure, the earth has opened so as to allow gravel to fall into the cracks. In other cases water and sand were shot out of the openings, the sand remaining. Chimneys were thrown to the southwest.

*Stewart's Point, Sonoma County*. — The shock was felt very severely here and resulted in the destruction of an unusually large barn, formerly a lumber mill, used for the housing of lumber wagons. The structure was leveled to the ground. Small wooden dwellings were but little affected. All chimneys were damaged and the hotel lost the plaster from the walls of the lower floor. In the upper story the plaster sustained only a few cracks. The village lies about 2.5 miles west of the fault.

East of Stewart's Point the bridge over the South Fork of the Gualala River (plate 69D) was damaged by the slumping of the river terrace on which its south end rests. It was subjected to a strong longitudinal, compressive stress, which resulted in a slight upward buckling of the bridge floor near the southern end, and marked bending and twisting of the tension rods in the 2 southernmost panels. The supports at the south end furthermore appear to have settled 13 inches, causing the floor and the last panel to assume a marked inclination. A hundred yards east of the wagon bridge is an older, dilapidated one, whose floor has been removed for some time. Its rickety aspect and crookedness render it an unsatisfactory object for study in this connection. There is, however, clear evidence of the slumping of the terrace at its south end, in a manner similar to that at the new bridge; yet the old bridge appears to have stood the compressive stress better than the new, and its south end has merely overridden the displaced masses of the terrace.

On both sides of the sharp bend of the river east of the two bridges are extensive landslides, making a clean sweep down the mountain side. The slide on the north side completely blocked the wagon road and was being removed at the time of the visit (May 12). It is of such a height and steepness as to menace the road at this point with renewed sliding in future, especially during wet weather.

*Gualala Valley*. — At Casey's ranch, half a mile west of the fault, the destruction was notably severe, one building having entirely collapsed, and the dwelling-house having

been badly strained by the shock. The ranch stands on the east edge of the ridge, west of the Gualala River, and the fault runs along the mountain side several hundred feet below it. The slope is a steep one, densely timbered except for its upper portion. Landslides were found over a large part of its surface, but only in a few isolated spots had they resulted in the complete removal of the original surface and the forest growing thereon; so that a view from across the river revealed no appreciable changes in the landscape. The slopes east of the river were similarly affected and the fallen timber produced a tangle not unlike that of extensive windfalls. In at least two places the river was temporarily dammed up by slides from both slopes meeting in the stream bed, but none of these dams was of noteworthy size.

On the ridge east of the Gualala Valley, the ranches of A. and Chas. Lancaster were examined and found to have suffered less damage than Casey's. Chimneys were broken, furniture was damaged, and a small slaughter-house collapsed, tho that structure was known to be a weak one to begin with.

Between the two ranches a fissure was found very similar to, tho smaller than, those characteristic of the fault-zone. Its trend was N. 75° E. No marked vertical movement was in evidence, and while the twisted sods and clods along its line clearly indicated a small horizontal movement, this could not be ascertained for lack of definite objects to measure it on.

*Plantation House, Sonoma County.* — Most of the houses in this place stood the shock well. One cottage which was crosed by one of the strongest fault fissures suffered the partial collapse of its underpinning. Had the displacement of the fault not been distributed over a zone 270 feet wide in this locality, the destruction would probably have been much greater. As it was, broken chimneys and windows and slight damage to underpinning were the principal destructive effects within the zone.

*Timber Cove, Sonoma County.* — Altho this town is fully 1.5 miles west of the fault, the intensity was apparently but little less than at places much closer to it. The underpinning of one dwelling collapsed, all brick and tile chimneys broke off, and household articles and furniture were thrown down with violence.

In the bluffs along the coast and in the numerous rock cuts along the wagon road, the rocks appeared loosened up, many old fissures having opened and left the rock masses in more or less unstable positions. Landslides, in rocky as well as in loose material, have occurred in a great number of places, tho none were at all extensive. #

*Fort Ross, Sonoma County.* — At Fort Ross, 0.75 mile from the fault, the intensity of the shock was probably greater than the actual damage would indicate. The old Russian Church and several other buildings suffered thru collapse of their underpinning, but all in a fair state of repair stood the shock, as did the more recently built dwellings.

The dwelling of Mr. G. W. Call, proprietor of the place, was violently shaken. The table was moved across the floor to the south and furniture generally was thrown to the ground. There was much broken crockery and glassware. The contents of a pantry, consisting of jars of preserved fruit, were nearly all thrown from the shelves. In cleaning up the wreck after the shock, 6 wheelbarrow loads of broken objects were picked up off the floors of the rooms. In Mr. Call's room a high case was thrown across the bed in which he was sleeping.

Mr. Call stated that in his neighborhood hanging lamps were caused to swing in a circle corresponding with the apparent movement of the sun. There were several shocks, quickly following each other; the first was not the strongest. They seemed to increase in force up to the third or fourth and to come from different directions. He judged that there was a strong vertical impulse. Chimney tops were thrown off, some chimneys being shattered to the bottom. Many redwood and pine trees were broken off, some at the ground, being uprooted; but generally broken about halfway up. All low fund-

ture was turned over, and a few frame buildings set upon unbraced posts were shaken down. The tendency along the fault seemed to be to crowd the two sides together, as a water-pipe in one place had sprung up in a curve out of the ground. The fact that he found no trees broken at a distance of more than a mile from the fault indicates to Mr. Call that the shock was much stronger near the fault than elsewhere.

Mr. Call resided for some years on the South American coast and had experienced the disastrous effects of sea waves consequent upon earthquakes in that region. The moment, therefore, that he felt the shock he turned his attention to the sea, which is in full view of his house. He reports that it was perfectly still during the shock and afterwards.

South of Fort Ross, at Doda's ranch, a large barn about 150 feet west of the fault was found leaning to one side on the verge of collapse. Several of the dwellings and other smaller houses had slipt from their underpinning. All the chimneys had been broken off or destroyed; household articles and furniture had been thrown down, but no window glass had been shattered or even cracked.

Mr. Doda's daughter stated that she was standing in the kitchen at the time of the shock, and was lifted vertically from the floor more than once, in each case alighting on her feet. A ranch hand who was out-of-doors at the time stated that he saw the water-tank thrown vertically upward about 5 feet and then fall in ruins.

In the forest between Plantation House and Fort Ross innumerable trees, many of them redwoods (*Sequoia sempervirens*) of considerable size, had broken off some distance from the ground (plate 69A, B), or had split lengthwise from the roots up. Some were uprooted altogether, as if by a hurricane. No particular preponderance in direction of throw was noted. Trees on the line of the fault were as a rule split vertically and more or less twisted. In some cases the butts had actually been sheared. A fine instance of this may be seen on the stage road 150 feet east of Plantation House.

At Seaview, a post-office on the summit of the ridge overlooking Fort Ross and probably 1.5 miles from the fault, the shock is described by Mr. Morgan, the occupant of the only house there, as very violent. In a room with two beds, one moved across the room to the south, the other was lifted from the floor. The chimney was thrown to the north.

On the wagon road from Seaview to Cazadero, the steep bank of the road-cuts, generally of disintegrated sandstone, had in numerous places slid down upon the road.

At Cazadero the shock was severe and chimneys were generally thrown, but no buildings were wrecked, all the structures being of wood. Mr. H. L. Conley, of this place, stated that according to his observation the shock was from north to south, chimneys falling south. In a store the chief walls of which trend north and south, hardly any damage was caused. Some pictures hanging against walls were turned around so as to face the walls. There seemed to be two maxima, the second being the strongest.

#### BETWEEN THE COAST AND THE UPPER RUSSIAN RIVER.

For thr territory between the coast and the upper Russian River Valley, we have the following notes by Dr. H. W. Fairbanks:

At Sewerville the shock was much less severe than at Santa Rosa. Chimneys and por-  
 tico of brick walk were thrown down. The shock at Skaggs Springs, 8 miles west of  
 (teywm)le, was not severe. Chimneys were knocked down, but no other damage was  
 done. On the wimmit of the ridge, 6 miles west of Skaggs Springs, chimneys and crockery  
 were broken, the shock apparently being fully as severe as at Skaggs. There are no other  
 TO !!f^m^l^r^l^v^r^.. d until within 2 miles of the Rift, where the shock

Another ^ction is that across the country from Point Arena to Cloverdale. At Boone-  
 ?T^l^v^m^all^the^k^te^a settlement. About half the chimneys were down  
 and Ik. Diddle, apparently the best-informed man in the town, thinks that the shock wa^



A. Bell and Kinslow building, Healdsburg. Per J.O.B.



B. Odd Fellows' Hall, Healdsburg. Per J. O. B.



somewhat more severe than at Ukiah. Booneville is a little more than halfway from Point Arena to Ukiah. Ten miles southeast of Booneville on the Cloverdale road, a point a little nearer the Russian River Valley than Booneville, no damage to speak of was done, one chimney being slightly cracked. Sixteen miles southeast of Booneville, a little more than halfway between that place and Cloverdale, milk was thrown out of pans and houses badly shaken. At a house a half mile away cream upon milk pans was not broken. On the mountain 5 miles west of Cloverdale there was no damage done. Two miles west of Cloverdale about half the chimneys were broken. The town itself does not seem to have suffered more than the average place along the road. Most of the chimneys were merely cracked and not thrown down.

While there seems to have been great variation in the intensity of the shock in the sections traversed, it is not clear that there was any increase in the intensity of the shock in the direction of the Russian River Valley at points between it and the coast.

Supplementary to these notes by Mr. Fairbanks, Mr. John L. Prather, of Philo, reports that at that place chimneys were thrown down and broken off above the roof, and in some cases turned quarter way round, clockwise. Glassware and crockery were generally broken and much damage was done in stores and farmhouses.

#### HEALDSBURG TO WILLETS.

*Healdsburg, Sonoma County.* Population 1,870. (R. S. Holway.) — This place comes next to Santa Rosa in the extent of damage done to towns in Sonoma County. The shock was definitely less severe, however. The new 3-story brick building of the Odd Fellows Society is a total wreck, as are several other buildings, but many brick structures stood the shock without serious damage. The cemetery is on a low hill similar to that at Santa Rosa, and as at the latter place not over half the monuments fell. Of 35 square monuments of the same class, the direction of fall was as follows: north, 10; south, 11; east, 10; west, 3; southwest, 1.

Along the bottom-land of the Russian River, cracks from an inch to a foot in width opened at several places.

(H. R. Bull.)—The direction of the earthquake at Healdsburg seemed to be from north to south during the early stage of the disturbance. Following this was a decided pause attended by a quivering motion; then followed a vertical movement attended by a great rumbling noise like thunder; lastly, the distinct oscillatory movement which continued thruout.

A piano with its back close against the north wall was shifted 2 feet almost directly toward the south. It was evidently lifted and rolled simultaneously, since the base-board of the piano was thrust out upon the floor ahead of the piano. A clock on a south wall was thrown 5 feet to the north, while a clock on a north wall was thrown to the south. Plastering on walls extending north and south was badly broken and scattered, while that of the ceiling and the walls extending east and west was only slightly injured. One chimney was hurled toward the east, another toward the south. North and south walls of a brick dwelling 40 feet north of the frame building above described were thrown toward the south. Furniture in this building was shifted also in a similar manner. Residents generally agree as to the general movement being from north to south.

Fissures in the creek bed near the town are in evidence. Water was thrown out and continued to flow for several hours, at first with some considerable force; then it gradually diminished and finally disappeared. Brick buildings were generally injured and in some instances thrown down. (Plate 70A, B.) Many brick walls facing east and west were buckled either in or out, because of the movement from north to south of the north and south walls. Chimneys generally fell north or south. In some east's the oscillatory motion caused chimneys which had withstood the north and south wave to fall in other directions.

(George Madeira.) In the bed-room a heavy walnut and marble composite bureau, mounted on rollers and weighing 400 pounds, was moved toward the center of the room by the first wave motion, which was north to south. It then turned so that the large mirror surmounting it was due north. In the house are three chimneys built close together. One chimney above the roof fell to the south; but beneath the roof one fell to the south, one to the north, and one to the east, on the ceilings of the back parlor, dining-room, and sitting-room respectively. A large pier glass 8 feet high, with a very heavy marble base, was turned northward. There were two maxima in the shock and the second was the more violent. The first was from north to south and the second from east to west. Not a building escaped damage to some extent, whether made of wood, brick, or stone. There were five brick buildings destroyed. Mr. Madeira estimates the loss at between \$200,000 and \$300,000. Along the creek and river bottoms the earth was fissured and water was forced up which, in some instances, flooded the orchards.

*Alexander Valley to Mt. St. Helena* (R. S. Hoiway). — This trip was made in order to cross the line of the fault described by Mr. V. Osmond<sup>1</sup> on the southwest slope of the mountain. No sign of recent movement was seen, however, and no reports of cracks or landslides were obtained. There are few houses from which to obtain reports. Some chimneys fell as far as Kellogg at the foot of the mountain. At Nays — elevation about 1,500 feet — and at the toll-house southeast of the summit — elevation about 2,300 feet — a severe shock was reported, but nothing was shaken down. In climbing the last 2,000 feet to the summit, large boulders were frequently seen balanced on points and yet not overturned by the shock. The intensity decreased from IX at Healdsburg to about VI on top of the mountain.

Alexander Valley is part of the Russian River Valley lying east of Lytton Springs. The main bridge across the Russian River was wrecked, the trestle-work part going down. The bridge was old and was to have been rebuilt this year. At the east end of the bridge cracks cross the road, northwest to southeast, parallel to the river bank. These cracks appear at intervals northwesterly, at least as far as the ranch of Rev. B. B. Ware, about a mile up the river. The cracks vary from a few inches to over a foot in width, and are sometimes 200 to 300 feet long, roughly parallel to the river. Mr. Ware states that the shock threw the river water upon the sandbars to such an extent that he found fish there during the day. Other cracks are reported a mile or two northward. Subsidence frequently occurs where the cracks are near the bank.

*Cracks in the Russian River Flood-plain* (R. S. Holway). — Cracks have been observed at intervals in the alluvial banks of the Russian River from near its mouth to Alexander Valley, 5 or 6 miles northeast of Healdsburg. These cracks are sometimes 100 yards in length and from a few inches to 2 feet in width. Sometimes near the bank there will be a deep fault 5 to 6 feet in width and 100 feet long, as shown in the photograph of the crack at Monte Rio. The direction of the cracks is usually parallel to the bank of the river or the bank of some small tributary. At Duncan Mills the cracks ran north and south above the bridge and nearly east and west just below the bend of the river. At Monte Rio they are east and west. In Alexander Valley they run north and south, while a mile or two below some are found nearly east and west running up a small tributary.

*Maacama Slide, 6 miles easterly from Healdsburg* (R. S. Holway). — This slide is on the north side of a ridge that runs in an easterly direction and that is at this point from 225 to 300 feet above the bed of Maacama Creek, which runs along the foot of the north slope. Mr. Hugh Simpson, whose house is just beyond the foot of the slide, states that the entire slide took place at the instant of the earthquake. The slide is about 0.125 mile wide at the top and about 0.5 mile long. The rock is a very light, porous, volcanic

---

<sup>1</sup> Bull. Dept. Geol., Univ. Cal., vol. 4, No. 3.

tuff and seems to be free from water. A slicken-sided wall on the east shows a very-smooth surface in spite of the soft rock. Striae near the top run N. 13° W. with a pitch of about 24°. The slide seems to have taken off some of the top of the ridge; that is, it started a few feet down the south slope of the ridge, cut its way thra a fir forest and dammed Maacama Creek with rocks and trees. Either two successive slides occurred or else the upper part of the moving mass was arrested part way down, for a bank with the vegetation of the top rests across the slide about one-third of the way down. (See plate 124A, §.)

This slide was subsequently visited by Mr. G. K. Gilbert, who contributes the following supplementary note:

At Maacama schoolhouse, I saw the large landslide described by Professor Holway. The rocks involved are in layers, with a dip of about 30° in the direction of the slide. It is therefore probable that the slide was partly determined by the dip, tho it seems to have been further determined by the erosion of the valley of Maacama Creek. The shock at that point was notably strong. A young man living close by told me that he was watering two horses at the time, and kept his feet only by holding on to a pump. Both horses were thrown down. The house of Mr. Stimson was thrown from the pegs on which it stood, and all brick chimneys in the neighborhood were broken. He and others mentioned numerous cracks in the bottom lands a mile to the north, and especially in the bottom lands of the Russian River at its neighboring large bend.

*Geyserville, Sonoma County* (R. S. Holway).—Shock reported north and south and northwest and southeast. Several brick buildings were badly cracked and tops of fire walls thrown down. The northwest wall of a butcher shop (brick) was thrown out against an adjoining frame building, which saved the brick building from an entire fall. Half or more of the chimneys were reported down. Goods were commonly thrown from shelving in stores. The cemetery 1.5 miles northwest in the low hills was not disturbed. The bridge across the Russian River at this point was unhurt. The town is on the west side of the river, on alluvial terraces.

*Cloverdale, Sonoma County* (R. S. Holway).—The upper walls of a brick building nearly opposite the United States Hotel were cracked so as to necessitate partial rebuilding. A 2-story brick building on First and West streets was unhurt except for cracked plastering. The shock was reported north and south; goods were thrown north and south from the east and west walls. In a 1-story brick building at Broad and West streets goods were thrown from the wall facing north. In the grocery opposite the United States Hotel goods were thrown mostly from the wall facing south. The inspector reports that he has condemned four-fifths of the chimneys, but most estimates agree that not over one-fourth fell. Mr. Scott reports that he went out-of-doors during the shock and that distinct waves in the ground could be seen moving from the west toward the east. The cemetery is on a knoll on the bank of Russian River, and suffered no damage except the fall of a vase from the top of a tall monument. This fell to the north.

(M. C. Baer.) On or about 9<sup>h</sup> 30<sup>m</sup> P. M., April 11, a slight shock (class III) was felt. The general direction seemed to be east and west and to have a trembling motion. The next shock came at 5<sup>h</sup> 13<sup>m</sup> A. M. on April 18, and was of about class VIII. The motion was at first oscillatory, but seemed to end up in a series of jerks. There did not seem to be any general direction. All chimneys were cracked; many windows were broken, and many brick chimneys and buildings were shaken down. The bricks of a chimney from a building about 30 feet high were thrown southward about 70 feet. Generally the chimneys seemed to have shifted or fallen southward, but in some cases they have tended to go in other directions. Many telephone wires were broken. In most cases water was spilt from water-tanks on all sides. It is reported that the water of several streams was partially thrown upon the banks. No cracks in the earth's surface have been reported.

*Ukiah, Mendocino County.* Population 2,000. (R. S. Holway.)—A brick building owned by Mrs. White was so badly damaged that it is being taken down. The north fire-wall of the McGlashan Building was thrown down and the engine house is reported unsafe. Mr. Cunningham, inspector of chimneys, reports some 30 to 40 actually down, but probably one-fourth of all chimneys condemned. Sexton Rogers reports no damage in the cemetery. The State Asylum for the Insane, a large brick building, is east of the river and some 2 miles away. The gables fell out, coping and ornamental stones fell from walls, and chimneys fell generally west or east. In one case, where a chimney was braced by an east and west rod, the washer was pulled thru into the flue, but the chimney remained standing. At Vichy Springs a greatly increased flow of water is reported. The water was milky for a few days. Increased temperature was reported, but no thermometer was used to determine this.

(Geo. McGowan.)—The town is partly on bottom-land and partly on a bench slightly above the bottom. There is no rock near the surface and none of the ordinary wells go to rock, but pass thru washt gravel and clay. Ukiah Valley is approximately 12 miles long, and 2.5 miles wide, lying about north-northwest and south-southeast, and surrounded by mountains. Russian River enters at the north end of the valley. At this place it is at the extreme east side and continues near the east side to its exit at the south end. The greater part of the valley floor is alluvial fill. It is nearly level except for a depression toward the south to correspond with the grade of the river. Ukiah is a little to the west of the center line of the valley and about 4 miles from the north end. There are several deep canyons at right angles to the valley in the bordering mountains.

In the town a 2-story brick building, rather flimsily built, the front being set on pillars, was canted about 6 inches to the south, breaking most of the plate glass in the front. It struck against a 2-story brick building just completed, also set on pillars, and the latter was set over nearly a foot and the walls badly cracked. The greater part of a long fire-wall on the north side of a 2-story brick building fell and an inner wall that served as the casing of a stairway was badly cracked. A large number of chimneys were dislocated and some were thrown down. Some of our well-built structures suffered. Quite a number of houses had the plastering more or less cracked. The railroad lost a large water-tank which was thrown down and demolished, tho a large oil-tank near by appears to be uninjured. The shock caused an old sheet-iron tank full of water to break loose at numerous points around the bottom and lose its contents in short order. Of two pendulum clocks one was stopt. Chimneys and loose objects were thrown to the north and south, some one way and some the other, and some chimneys that were not thrown were dislocated and turned partly around, in a direction opposite the apparent motion of the sun. The electric-light bulb hanging over my bed swung first back and forth, then changed to an ellipse and finally almost to a circle. There were two principal maxima, of which the first was the stronger. The first movement was north-northwest and south-southeast and this was succeeded by a twisting motion.

Mr. S. D. Townley, in charge of the International Latitude Observatory, 1 mile south of Ukiah, reports:

Many chimneys were thrown down from 2-story buildings, and also from some cottages. One new brick store building just nearing completion was so badly cracked and thrown out of plumb that it is necessary to tear it down, and several other brick buildings were damaged to a greater or less extent. The particulars are given in the *Ukiah Press* for April 27. A rough estimate of the number of diirnneys in town would be 1,000. P. B. Westerman, teacher in the Ukiah High School, reports that 120 chimneys fell, most of them either to the north or south. At the Asylum on the eastern side of the valley, chimneys fell to the east or west. Cemetery monuments were not overthrown. One chimney on a house 200 yards southeast of the Observatory was badly cracked.

At the Latitude Station no damage whatever was done, altho the shaking was the most severe ever experienced by the writer. Dishes rattled, milk was spilt from pans little

more than half full, and fowls and other domestic animals were very much perturbed. There was a series of shocks, and reliable estimates of their duration vary from 20 seconds to 1 minute. The general direction seemed to be from southwest toward northeast, but others report a different direction. The Uldah Valley is surrounded by mountains of considerable altitude, and it is probable that some of the shocks felt were reflected from the mountains. Hence it is that the earthquake is generally spoken of as a "twister."

The Observatory clock was not stopt, but it lost 6 seconds during the disturbance, which is equivalent to being stopt for that length of time and then set going again. The Observatory roof is built in two sections, which roll upon horizontal tracks, east and west, giving an opening of about 13 meters for observation. When closed the two parts are fastened together by means of a hook and eye such as are used on screen doors. The hook rests in a horizontal position and the bend of the hook in a meridian plane. The effect of the earthquake was to unfasten this hook and open the roof to the width of about 20 centimeters, my recollection being that the eastern half was moved about twice as far as the western. The pier upon which the zenith telescope rests was apparently not damaged, but the telescope was thrown considerably out of adjustment. It was out about 15 seconds of arc in azimuth and the vertical axis was out in both directions, but not much more than sometimes results from extreme changes in temperature.

The first series of shocks was followed by three lighter shocks and the observed data for each are as follows:

PACIFIC STANDARD TIME.				DURATION ABOUT.	DIRECTION.	INTENSITY.
Apr.	IS <sup>d</sup>	5 <sup>d</sup>	13 <sup>m</sup> — <sup>B</sup> A. M.	40 <sup>s</sup>	SW. to NE.	Severe
	IS	10	4 39 A. M.	10	SW. to NE.	Medium
	18	11	36 0 A. M.	30	SW. to NE.	Light
	20	12	30 53 A. M.	—	—	Very slight

The times are correct within 2 or 3 seconds.

I was in the observatory at the time of the second series of shocks, 10<sup>h</sup> 4<sup>m</sup>, and perceived the effect of the movement in the striding level (east and west) of the zenith telescope. The bubble oscillated over about 2 divisions of the level. The value of one division is 2.2", and as the distance between the east and west leveling screws of the instrument is about 42 cm., the disturbance produced in the bubble was equivalent to the effect of raising and lowering one of the leveling screws by 0.0005 centimeter. This shock was felt very distinctly and it is probable that the north and south component of the motion was much greater than the east and west component. The fourth shock was not felt at all. It was detected during the progress of latitude observations, by a movement of the bubbles of the latitude levels. The oscillation (north and south) was about one-half of one division, and the value of one division is 1 inch.

My estimate of the intensities for the four shocks given above would be, respective<sup>ly</sup>, VII, IV, III, I. The Observatory is about a mile south of the city of Ukiah, and it seems certain that the earthquake was more severe in Ukiah than at the Observatory. The intensity of the first shock at Ukiah would certainly not be less than VIII, possibly IX.

The direction of all shocks was southwest to northeast, according to bodily impression.

*Willets, Mendocino County* (R. S. Holway). —• Brick chimneys were quite generally wrecked. The Buekner Hotel was completely demolished. One wall fell at the time of the shock, killing Mr. Taylor, **the** proprietor. The building finally fell at 10<sup>h</sup> 20<sup>m</sup> A. M. The structure was largely frame, with some brick veneer. The stores of the Irvine Muir Company were badly wrecked. Fire-walls **foiled**; plaster, shelving, and goods were thrown to the floor. Brick walls fell in several other stores, and frame buildings were in some cases thrown from their foundations. Small cracks across some of the streets were reported, but they are not now visible. All brick buildings were damaged to some extent. A tank 2 or 3 miles to the east threw the water out on the northwest and southeast. Colonel La Motte, at the spawning station 5 miles north of Willets, stated that the water of a pool 8 to 12 feet in diameter and 2 feet deep splashed out on the south and southeast, wetting the pickets to a height of 15 inches. It did not splash out in any other

direction- The valley is an old lake bed with ground water within 3 to 4 feet of the surface in April. (See plate 73B.)

At Hemlock, 14 miles east of Ukiah, the shock, according to a report by Mr. C. D. L. Bowen, had two maxima, the second being the stronger. A rotary motion was felt, but no damage was done.

#### CLEAR LAKE DISTRICT.

For the Clear Lake district to the east of the Upper Russian River Valley, the following notes are from a report by Mr. C. E. Weaver:

*Holland to Lakeport.* — Nothing of importance was observed along the road from Hopland to Highland Springs. At the latter place one chimney fell. No cracks nor fissures could be seen. From Highland Springs to Lakeport no cracks were seen, and upon inquiry none were reported. The damage to buildings was slight; only a few chimneys were thrown down.

At Lakeport several brick buildings and one frame building were partly destroyed. A brick building was completely destroyed and most of the chimneys were thrown down. Many chimneys not actually thrown were twisted, and in every case the direction of the rotation was clockwise. All 6 chimneys of the high school building were twisted thru an angle of about 20°. Clocks in general stopt. No fissures nor cracks are reported or were found. The town is built on alluvium.

*Upper Lake.* — The intensity of the shock is said to have been greater at Upper Lake than at Lakeport. There are, however, no brick buildings there, and only chimneys went down. No cracks nor fissures were formed. This town is also on alluvium.

*Laurel Dell* — A crack having been reported at Blue Lake, near Laurel Dell, Mr. Weaver visited the place, but found only a minor slide on the roadside. At Laurel Dell and Blue Lake Hotel chimneys fell. The first story of Laurel Dell Hotel, built of stone, was not affected. No cracks nor fissures were seen or reported between Upper Lake and Lakeport.

*Lakeport to Lower Lake.* — Between Lakeport and Kelseyville, a distance of 9 miles, a few chimneys were down along the road. Houses are few, however. At Kelseyville, on a wide alluvial flat, brick buildings were somewhat damaged, and chimneys generally were down. The shock was reported to be of about the same severity as at Lakeport. The shock was described by residents as having had first a north to south motion, then east to west, then a twist. One mile south of Kelseyville and half a mile to the west, at the place of Mr. McLaughlin on the Lower Lake county road, a crack was found in the alluvium out of which gas escaped, burning upon ignition. About one mile north are gas wells in the same kind of rock, the gas being obtained by boring to a depth of 165 feet.

About 3.75 miles south of Kelseyville on the road to Lower Lake, at the ranch of Mr. M. E. D. Bates, is a crack varying in width from 1 to 6 inches. It crosses the road about 200 feet below the house. At the right of the road going south it crosses the creek and can be seen no further. At the left of the road it passes up the hill toward Uncle Sam Mountain for about a mile, but is not continuous. Near the road two small trees standing on the crack have been partly uprooted and a fence post has been thrown out entirely. The rock thru which the crack passes is alluvium and a loose, unconsolidated conglomerate. It apparently does not pass thru the hard Franciscan rocks. In places there are as many as 10 parallel cracks, separated by intervals of 5 to 10 feet, which could be traced for only short distances. On the right side of the road, about 100 feet south of the cracks, stands a schoolhouse. It has been slightly tilted to the south. The chimney, made of terra cotta, is bent to the south. The chimneys on the house of Mr. Bates fell.

On the side of Mount Konocti, several large loose boulders were caused to roll down, but no landslides nor cracks were observed.

*Cache Creek Canyon.* — On Sunday, May 1, a large slide occurred on the side of Cache Creek Canyon. Mr. Weaver visited this and reports that the slide occurred about 4 miles below the junction of the north and south branches of Cache Creek. The creek here flows thru a canyon not more than 1,000 feet wide, with steep walls on each side. At the point where the slide occurred, the creek makes a bend. The rock which slid is a red sandstone. The distance from the creek to the point where the slide began is about 500 feet. The width of the slide is about 300 feet. It occurred on the south side of the canyon and dammed up the latter to a height of 90 feet. The water rose to that level and one week later, May 7, the dam broke and allowed the water to escape down the valley. Nearly all the material was carried off by the water.

At the base of the cliff where the slide occurred are several very large springs; it is stated by Mr. Brainard that springs were common at the base before the slide occurred. About 500 feet back from the upper edge of the slide there is another crack, having a width of from 2 to 6 inches. It is about 300 feet long and the mass of rock in front of it appears ready to slip. No other cracks were seen.

At Middleton the shock was not especially severe. The brick hotel was not injured, but some chimneys were down.

At the toll-house on Mount St. Helena no chimneys were down and the shock was not especially severe.

At Oat Hill, at an elevation of 2,000 feet, on a mountain slope facing east, Mr. J. J. Multer reports that no damage was sustained in consequence of the earthquake. The shock comprized two parts, of which the second was the stronger. The direction of movement was northwest and southeast.

*Vicinity of Upper Lake.* — Charles Miffiin Hammond says:

I live about 4 miles southeast of Upper Lake, in the approximate latitude of  $39^{\circ} 10'$  N. and longitude  $122^{\circ} 45' W.$ , at an elevation above the sea of 1,350 feet, and about 50 feet above the surface of Clear Lake. The house is 45 by 90 feet, well built, and a story and a half high. In it I have a collection of about 70 clocks, of all ages, styles, and makes. These stand on mantelpieces, on shelves, on the floor, on bookcases, and some are hung on the walls. I have no absolutely correct time, but on the morning of April 18, between  $5^h 13^{m}$  and  $5^h 14^{m}$ , my wife and I, who were asleep, were awakened by a violent rocking of the house. We jumped to a doorway and stood there for about 2 minutes, the house gradually coming to a state of rest from its violent rocking and swaying, and a roaring noise passing off in a southwest direction. This direction is corroborated by some of the men on the place who were up at the time. They all said that they suddenly heard a noise in the trees as tho a heavy wind was blowing thru them, and that the rumbling past away to the southwest. There was only one maximum and the movement certainly came from the northeast.

I at once made an examination of the house. The southwest room showed the greatest disturbance. From the top of a small bookcase facing west a large china vase was thrown to the floor and smashed. On my desk, facing north, stood a spy-glass 2 feet high, which was tipped over to the southwest. In the southeast corner room, on a mantel facing southwest, a vase of flowers was tipped over to the southwest. Practically every one of my pendulum clocks had stopt, with two notable exceptions. In the southeast corner room, there stands on a small shelf facing northwest a very delicate Empire clock, which a sheet of paper put under one leg will stop. The clock kept on running, as it did thru all of the later earthquakes. In the southwest corner room there is another delicate clock standing on a bookcase facing southeast. This clock causes me a great deal of trouble, as the slightest variation in its level stops it; yet it was going after the main shock.

At 10 o'clock that morning there was another shock, which was not very perceptible, yet it caused the above clock to stop, and also a few others. At  $11^h 40^{m}$  I happened to be in the house starting the stopt clocks for a second time, when there came a third shock which again caused some of the clocks to stop.

On May 6, at  $8^h 10^{m}$  p. M., a very violent shock came from almost due east. We were sitting on the piazza, and it came without a second's warning. I judged it to be fully as severe as the one of April 18, but it lasted only about 10 seconds. In the southeast room, from the same mantel, a small wooden clock was thrown out on the floor to the southwest.

In the southwest room the same spy-glass was upset toward the northeast, and from the top of the tall bookcase, from which had before been thrown the china vase, a bronze figure a foot high was precipitated to the southwest. In the hall, on a bookcase facing west, a small wooden clock was tipped over to the east against the wall. At 9 o'clock that evening there was another shock almost as heavy as the first one, but by that time I was too rattled to take much note of it, especially as I had not started the clocks up again. But the next morning I went at them, and found that in some cases the pendulum had been swung out of the wire loop from the escapement. I tried to locate the direction of the quake from the condition of the clocks, but found that they had stopt indiscriminately, without regard to length of pendulum or direction. They have pendulums ranging from a few inches long to several feet. No plaster was cracked in the house, but many pictures were out of line, and the quakes of May 6 broke off two of my chimney tops at the roof line, the southwest corners of both being moved about 0.75 of an inch in that direction.

In the Rossi-Forel scale, I placed the shock of April 18 in class VIII and those of May 6 in class VII. In none of the shocks was any disturbance noticed on the waters of the lake, nor was there evidence of there having been any waves, yet on the 18th a plank connecting my floating boat-house with the bank was found with its outer end in the water, showing that the boat-house had been pulled away from it. This plank ran about east and west. In all of the shocks the house seemed simply to sway backwards and forwards. There appeared to be no up and down movement. In the cellar under the house the milk was thrown from the pans in a northeast and southwest direction.

*Bartlett Springs* (Mrs. M. E. Clark). — My husband past the night of April 17 at Upper Lake, where the shock was quite severe, but my son, a boy 16 years of age, was on the ranch, 5 miles northwest of Bartlett Springs. The shock was severe enough to stop the clock. He and another boy felt the prolonged tremor and the rocking of the house. They were dressing when the shock occurred. Nothing, however, was reported as having been knocked over, nor was any milk spilt from pans. At our nearest neighbor's, 4 miles northwest of our ranch, nothing was known of the earthquake till it was mentioned to them 3 days after the event, altho a member of the family thought he felt something. At another neighbor's, 5 miles northwest of here, at Horse Mountain, the wife was awakened but not the husband. At Twin Valleys Ranch, a smart shock was felt and the clock was stopt.

*Lower Lake* (W. C. Goldsmith). — No chimneys were thrown down in the town, but 2 chimney tops fell to the southwest at a point about one mile northeast of the town. Mr. Weaver reports that Lower Lake is on Eocene sandstone, and that the shock was much less than at Lakeport or Upper Lake.

*Sanhedrin, Lake County* (V. L. Frasier). — This place is in a small alluviated valley surrounded by mountains. One shock was felt which was not severe enough to throw chimneys. The motion was from northwest to southeast. Some men in a tunnel in solid rock, 800 feet below the surface, did not feel the shock, and people living on the surrounding mountains report the shock as much lighter than in the valley.

In the district about Knoxville, Mr. Weaver reports that a few chimneys at ranch houses fell, but that no severe damage was occasioned. To the east of the crest of the Coast Ranges, in the latitude thus far considered, observations indicative of the intensity of the shock become more scattering, and people generally attached little importance to their experiences of the morning of April 18.

#### FORT ROSS TO BODEGA HEAD.

We return now to the coast south of Fort Ross. An examination of the coast between Fort Ross and Bodega Head was made by Prof. J. N. LeConte and Mr. A. C. Wright. The portion of their report dealing with the distribution of intensity follows:

From Fort Ross the line of the earthquake fissure was followed south to the point where it passes into the sea. From this point we followed the beach for 8 miles. Several slides were seen about 3 miles south of the Fort. One of these was of great size, being between



300 and 400 feet in height. These are evidently old slides, and the amount of material brought down by the recent earthquake, though large, is insignificant compared with the size of the scar. At Rools Landing the beach was abandoned, and the wagon road was followed to Davis Mill at the mouth of the Russian River. The earthquake here had caused several thousand dollars' damage to trestles on the logging railroads. No buildings were moved on their foundations, only chimneys being thrown down.

From this point the road along the bench above the sea was followed 12 miles to Bodega Bay (see map No. 4). The country is sparsely settled. Only three or four houses were past, and these were uninjured except for broken chimneys. Near Bodega Head the bridge over Salmon Creek was somewhat twisted. Just beyond this a good-sized hotel, previously used as a summer resort, was badly wrecked by the earthquake. It was moved on its foundations, and rendered unfit for habitation. This building was close to the sand-dunes and probably rested on sandy deposits. The barn was completely wrecked. A few hundred yards beyond this a small mud-flat extends from the sea up to the road. Curious mounds of mud, shaped like truncated cones, were thrown up by the earthquake. Subsequent examination showed that the line of the earthquake fissure must have past near this spot.

*Duncan's Mills* (J. Parmeter). — On the Russian River, when fisherman tried to seine fish after the earthquake of April 18, their nets were torn to pieces by snags, etc., where there had formerly been no obstruction. Large trees that had been buried in the bed of the river were lifted up by the convulsion, while other trees vanished that had been in sight. Low places in the river bed were made high and *vice versa*.

The bottom of the river appears to have dropt 2 feet all along by Duncan's Mills for 2 miles; and at the mouth of the river, where there used to be water 12 or 14 feet deep, there is now only 2 feet, and a riffle till boats can hardly cross, for a length of almost a mile. For over a mile there is now a strong current, where there used to be quiet water with very little current. A man who was by the river, near Monte Rio, when the earthquake occurred, told the Parmeters that he saw the muddy bottom of the river rise to the surface, and the water ran off over the banks. The bottom was the highest where the water had been 8 or 10 feet deep; then it settled back. A road and fence moved 10 feet. On the other side of Russian River from Duncan's Mills, 200 or 250 feet back from the stream, the earthquake made many holes thru which black sand and water blew up. Such blow-holes were made all along this river. Between the river and the ruined hotel at Duncan's is an irregular crack about 20 feet wide, 80 feet long, and 1.5 to 4 feet deep, with a blow-hole 4.5 feet wide and 2 feet deep where coarse river gravel came up.

(R. S. Holway.)—One hotel at Duncan's Mills was completely wrecked and other buildings were much damaged. Along the river there were several cracks in the alluvium.

(I. E. Thayer.)—The shake was of great severity on the Russian River at Duncan's Mills, and totally destroyed a large hotel. Several small houses were thrown from their foundations.

#### TOMALES BAY TO BOLINAS BAY.

BY G. K. GILBERT.

The following data upon intensity were gathered, with slight exceptions, between April 23 and May 12, 1906. In their arrangement the order followed is: (1) The line of the fault from south to north; (2) the towns of the Rift belt; (3) the peninsula west of the Rift; (4) routes of travel east of the Rift; and (5) distribution.

*Along the Fault.* — Mrs. Steele's farm buildings, near the head of Tomales Lagoon, stood in a very narrow fault-sag which was traversed by the fault-trace. At this point the trace consists of a group of cracks 10 to 20 feet broad. The barn, resting partly on the ground traversed by these cracks, was demolished so that, as I saw it, it lay in ruins. The house, standing only a few feet to the east of the fault, was thrown from its underpinning and a wing was partly separated from it.

The buildings of E. E. Strain, 1.5 miles north of Bolinas Lagoon, stand about 20 rods east of the fault-trace, the house being on a hill and the other buildings on sloping alluvium at its base. The house did not leave its brick foundation, but the foundation was cracked. Chimneys were thrown down. The other buildings were thrown from their underpinning, moving eastward. Milking was in progress in the barnyard. Some cows were thrown down, and Mr. Strain himself was thrown to the ground, but rose and grasped a tree, of which he retained hold with much difficulty.

Daniel Bondiotti lives 3.5 miles north from the head of the lagoon, and his buildings are about 20 rods east of the main crack. His house was shifted 3 feet toward the fault and his barn moved in the same direction. Men engaged in milking were thrown in a direction away from the fault — that is, to the northeast—and cows were also thrown in this direction.

At a barnyard near Bondiotti's, and east of the fault, a milker was thrown to the west — that is, toward the fault.

At Beisler's ranch, a short distance north of Bondiotti's, the fault-trace is in two parts, of which the western or main part passes under the barn, and the eastern between the house and the barn. Mr. Beisler was milking a cow at a point within 6 feet of the west branch, and on the southwest side. He was thrown to the southwest, arose, and started to go in the opposite direction, when he saw the crack in the ground; he then turned and was again thrown, but with difficulty reached a fence 10 or 15 feet away before the end of the shock. His house and buildings were strained, but they did not collapse, and their shifting was slight. The greatest shifting was of the main part of his barn, which stood between the branches of the fault and moved about 2 feet to the northwest. A water-tank near the fault was shifted slightly but did not overturn. At both the Bondiotti and Beisler ranches the surface of the ground has considerable slope and it is probable that bedrock is not far below the surface.

The buildings of the Dickson ranch, 2.5 miles south of Olema, are about 0.25 mile east of the fault-trace, standing on a hillside presumably on firm ground. They nearly all slid southwest — that is, downhill and toward the fault. The barn, an old building, collapsed.

At the Bloom place, a mile south of Olema, the buildings stand 30 or 40 rods east of the fault, and are on firm ground. The injury to buildings was here comparatively small. A water-pipe by which water was brought from a point on the opposite side of the fault was broken in many places, being at some points pulled apart and at others telescoped. At one place it buckled so as to project several feet above the ground. After being repaired, the pipe was found to be shorter than before, the difference being estimated at about 5 feet. I did not examine the course of the pipe, but from its general direction I infer that it crossed the fault obliquely from south to north, and that the shortening was the direct result of the horizontal throw of the fault.

Mr. Payne J. Shafter's place is near the village of Olema. The fault-trace is close to the house and other buildings. These stand on a bed of alluvium which is probably supported by bedrock at a short distance below the surface. In the barnyard men were milking, and were thrown violently to the ground, along with the cattle. The buildings were much damaged. During the earthquake a cow fell into the fault-crack and the earth closed in on her, so that only the tail remained visible. At the time of my visit the tail had disappeared, being eaten by dogs, but there was abundant testimony to substantiate the statement. As the fault-trace in that neighborhood showed no cracks large enough to receive a cow, it would appear that during the production of the fault there was a temporary parting of the walls.

Mr. Skinner's ranch is 0.5 mile west of Olema and on the line of the fault. The trace passes within about 10 feet of the house and within 2 or 3 feet of the dairy, and runs under a portion of a large emv-barn. The house stands southwest of the fault-line, and is on the block which moved northwest. The house itself was shifted northwest with reference

to the ground. (See fig. 22.) A granary standing 100 feet farther west than the house was shifted southward about 3 feet. The movements of the house and granary were thus in nearly opposite directions. The dairy remained on its foundations. The barn was not shifted on the earth block supporting its greater part, but was dragged along over the other block. Movables in the buildings were thrown about with violence; dishes, etc., were broken; but no buildings were destroyed and all were afterward repaired and used. A circular water-tank standing on a trestle about 12 feet high, approximately 100 feet northeast of the fault, was uninjured, and seemed to be absolutely undisturbed. In the barn-yard, which was traversed by the fault, cows were assembled and several men were engaged in milking. Cows and men were all thrown to the ground, the direction of their fall being northeastward and away from the fault. This direction was also downhill.

The road from the Skinner place to Olema crosses a small creek, and near the bridge is a deep pool. Water from this pool was thrown out to the southwest, being carried across the road a total distance of 3 or 4 rods.

*Bolinas.* — At the south end of the peninsula is a sloping plain carved by the sea when the land stood lower than it now does. Its general form and relations are shown by the contours of the map, fig. 10. This plain originally extended at least as far as the shore of Bolinas Lagoon, but east of Paradise Valley it has been modified by changes associated with the Rift. The line of Paradise Valley, when extended southeastward parallel to the fault-trace, marks approximately the limit of the Rift in that direction, and all the land between it and the fault-trace is broken into blocks which have been diversely faulted and tilted. As some of these blocks retain the smooth upper surface which they received as parts of the plain of marine denudation, their present attitudes serve to express the nature of the dislocations. Two small blocks facing the southern part of Bolinas Lagoon retain approximately their original height, but are tilted at different angles toward the northeast. A third block, too narrow to be caught by the map contours, has dropt 50 feet lower and is tilted at a still higher angle toward the northeast. A fourth and much larger block, itself involving minor dislocations, slopes southward from a point opposite the head of Paradise Valley to the delta of Pine Gulch Creek. The upper part of the village of Bolinas lies in a curving fault-sag among these dislocated blocks, and another portion stands on the delta of Pine Gulch Creek. In the fault-sag, where the ground was much cracked, nearly all the houses were either shifted on their foundations or else thrown from their foundations. There was great destruction of furniture and other breakable articles. In some cases people were thrown from their beds, but none were seriously injured. Three buildings which had stood on stilts along the shore of the lagoon were tipped toward it so that their lower edges came within reach of the tide. Several buildings were so badly injured that they were afterward torn down by their owners instead of being repaired. Just outside the fault-sag, and only a few rods distant, a group of houses stand on higher ground, and these were comparatively uninjured. They were not moved on their foundations, and in one instance the chimneys were not thrown down.

In the northern part of the town, standing on the delta of Pine Gulch Creek, about half the buildings were thrown from their foundations, and here also the destruction was greater on low flat land than on higher ground.

*Olema.* — The village of Olema is about 0.5 mile east of the fault-trace and at the edge of the Rift belt, the greater part being included within the Rift. The residence of Mr. Pease, standing on alluvium, was shifted south about 2 feet, falling from its supports. It was very badly wracked, and was eventually torn down. A neighboring piece of alluvial land bordering Olema Creek sank about 2 feet. The hotel owned by Mr. Nelson, standing on-higher ground, was somewhat, wracked but was not shifted. A house next door moved 2.5 feet to the northeast. A house opposite moved 2 feet to the northwest. Another house opposite fell from its supports, moving southwest. A neighboring stable



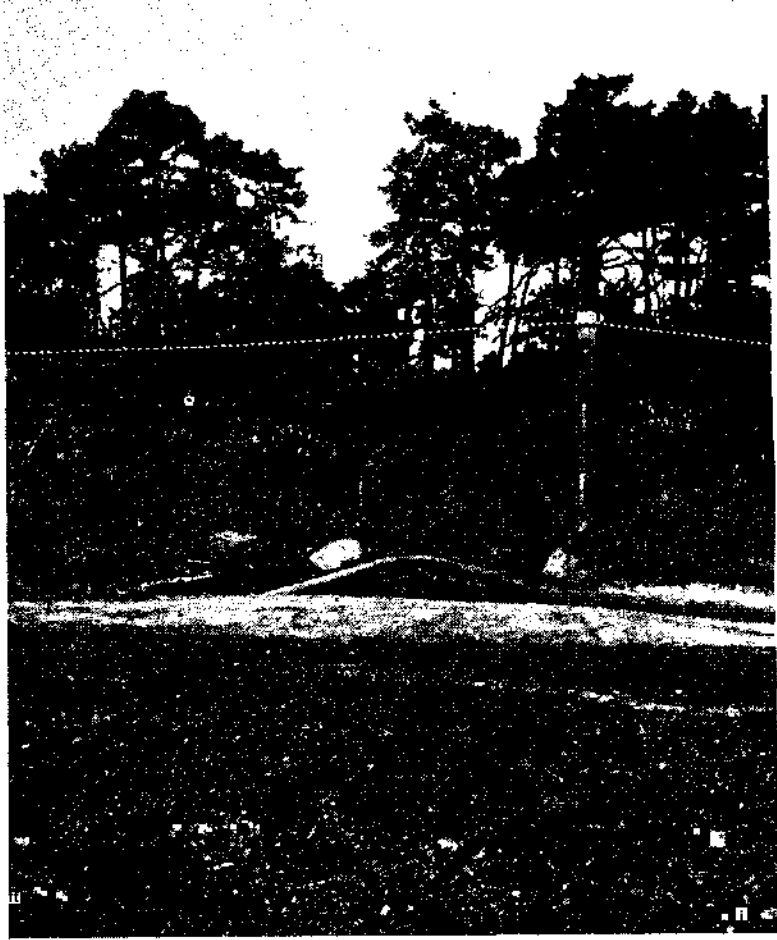

A. Buckled water-pipej Inverness. Gi Ki Q.



B. "Wrecked water-tank, near Inverness. Gh E. G.



A. Ruin of Inverness reservoir, a circular tank which before earthquake stood in fine. Parts of shed also lie in foreground, about 50 feet from original position. G. K. G.

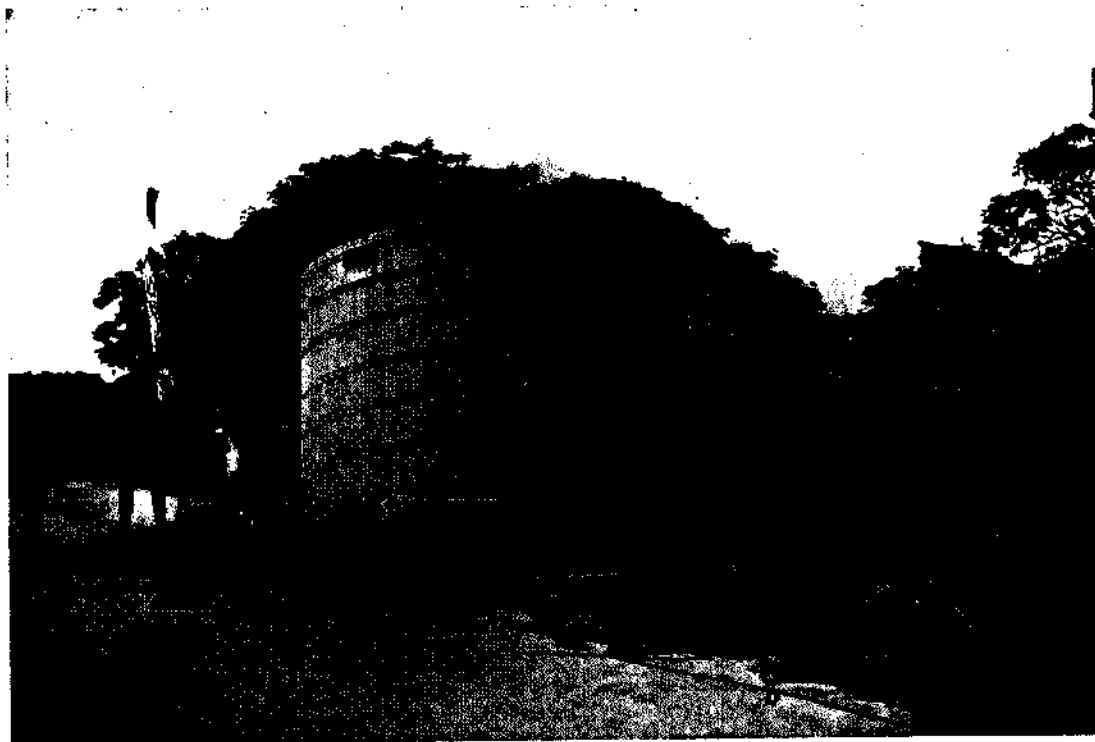

B. "Wrecked water-tank near Iawraets. Q. K. G.

small. In the neighborhood of Limantour Bay (indicated on some maps as Drake's Estero) there are a number of ranches. Most of these showed broken chimneys; but at a ranch west of the head of the bay 2 brick chimneys stood uninjured. At Point Reyes Post-office, the main residence building was thrown from its foundation of props and shifted 2 feet westward, being badly wrecked. Other buildings of the same group were not shifted, and 2 water-tanks on high frames seemed to be uninjured. At Mr. Claussen's ranch, south of the Post-office, 2 buildings were shifted a few inches to the south, that direction not being determined by their structure but being diagonal to their sides. The chimneys were thrown down, plastering cracked, furniture shifted, and many dishes broken. A picture was reversed so as to hang face to the wall. Mr. Claussen, being out-of-doors at the time, was thrown down. Some cows were also thrown down.

At the U. S. Life Saving Station, on the coast 3 or 4 miles from the light-house, brick chimneys were broken but not thrown down, furniture was moved, dishes were broken, and the filled ground about the house settled several inches. A mast standing in the sand was said to have been heaved up several feet, but its position had been restored before my visit. My informant said that he was standing when the shock came, and sat down to avoid falling.

At Point Reyes Light-house the heavy mechanism controlling the light was shifted several inches on its base. A lens "jumped" from its ways. It was so held in place by dowel pins that its movement required a lift of about 2 inches. The only injury to buildings was from the cracking of chimneys. Wooden tanks with water were not shifted. One of the light-house keepers stated that after the shock he looked from the window of his room, which commanded a portion of the sea near the beach, and saw the water "boiling," but there was no change of the nature of a wave.

*Sunshine Ranch and Vicinity.* — I drove to the summit of the ridge southwest of the head of Tomales Bay, finding abundant and strong road-cracks all the way to the crest, which is about 1.5 miles from the fault-trace. There were also a number of landslides in this region, and a considerable number of trees were broken or uprooted. There were few houses. The only ranch visited, known as the Sunshine Ranch, and occupied by Mr. Silver, suffered as severely as the houses of Inverness and Bolinas. The house moved southwest 3 feet and was badly wrecked. The dairy was thrown from its foundation and wrecked beyond repair. The barn, a large building, fell northward downhill and collapsed.

*Bear Valley.* — I drove from Skinner's ranch southwestward thru a pass in the upland, covering two-thirds of the distance to the coast, and reaching a point about 3.5 miles in a direct line from the fault. The most striking evidence of violence was shown by the trees. A few were thrown down, including oaks and spruces; branches were broken from others and some spruces had lost their tops. Most of these phenomena were seen within 0.5 mile of the fault. In the same region are a few summer cottages, which sustained little injury, only the fall of chimneys being noted. The club-house of the Country Club, situated about 1 mile from the fault, lost chimneys but was not shifted. One of its barns was wrecked, falling downhill in a southerly direction. In this region I saw only a few cracks other than road-cracks, and the road-cracks were unimportant.

*Seven Lakes.* — Crossing the main divide of the peninsula near the head of Pine Gulch Creek, I followed a road to the vicinity of the coast, a district known as Seven Lakes. As the trip was made 5 months after the earthquake, the evidence from road-cracks had disappeared. There were a few landslides, and a number of cracks already mentioned (page 75) testified to movements of large blocks of ground; but I think these were due to a peculiarly sensitive condition of the country rather than to the violence of the shock. At 2 ranch-houses not far from the ocean, chimneys were broken but buildings were not shifted. A few dishes were thrown down, but otherwise there was no injury to movables or houses.

*West of Bolinas.* — Driving 2 miles west of Bolinas, and looking at buildings from the road, I saw very little evidence of injury. At a distance of about 0.5 mile from the fault a chimney was broken at the roof, but not lower down.

*North of Point Reyes Station.* — I drove a few miles north and east from the station, over a high terrace separating the upland from the bay at the east. The injury to buildings was found to be much less there than at the station, and not all chimneys were thrown down. A large barn was seen to lean as tho some of its props had given out; two water-tanks were wrecked. A few cracks were seen in the ground, but they were much smaller and less numerous than at a similar distance on the opposite side of the fault.

*Sausalito to Point Reyes Station.* — Observation was made only from the car-window. The towns from Sausalito to Fairfax showed no damage more serious than the loss of a portion of the chimneys. The same remark applies to buildings seen along Papermill Creek as far as Garcia. Beyond Garcia the creek has several reaches of alluvial bottom, and some of these were so badly shaken that the railway embankments and trestles had to be repaired. Railway traffic to Point Reyes was interrupted for about 10 days.

*Ross to Bolinas.* — This road was driven over 8 days after the earthquake. In the village of Ross houses were not shifted. The principal injury is to brick chimneys, of which probably more than one-half fell. A group of stone buildings on a hill lost heavy stone chimneys, and there was injury to a tower. Some stone fences on alluvial ground were in part thrown down. These fences were of undrest stone, loosely piled. In San Anselmo most of the brick chimneys were broken, but other injuries in that town and in Fairfax appear to have been slight. Along the road from Fairfax to Bolinas Ridge, the only evidence of the earthquake consisted of small road-cracks, with occasional stones fallen from the road-cuts. These evidences of moderate disturbance continued down the western slope of Bolinas Ridge to the edge of Bolinas Lagoon. A house standing in the middle of the valley, probably 0.25 mile from the main fault, showed from a distance evidence of considerable disturbance. Its chimneys were broken, the house itself had probably been shifted on its foundations, and one of the outhouses was out of plumb, apparently having slidden downhill toward the northward. The house was not visited, but was merely seen from the road.

The general fact brought out in this drive was that the region about Ross and Fairfax experienced a shock comparable with that at Berkeley, and there was no evidence of high intensity until the fault-trace was closely approached. Landslides were not seen east of the lagoon, and the road-cracks east of the lagoon were not important.

*Mill Valley to Bolinas.*—At Mill Valley the visible injury was chiefly to chimneys. Extended enquiries were not made; but no reports were heard of destruction to furniture. The houses were not shifted. The buildings at West Point, on the Tamalpais Railway, did not suffer; and I was told that there was no injury from the earthquake at the hotel on the summit of the mountain. From crags on the south slope of Mount Tamalpais, stones were detached and rolled down the slope. The same thing occurred near Willow Camp. From West Point to Willow Camp there are no buildings, road-cracks were small, and no landslides were seen. A few stones fell to the road from the side of the road-cut. A ranch 0.5 mile east of Willow Camp showed no injury to buildings. At Willow Camp all brick chimneys fell, several houses moved a few inches toward the southeast, and dishes were thrown from shelves. A tall house 0.5 mile to the northeast was apparently not disturbed, and retained its brick chimney. Farther up the shore of the lagoon, and nearly opposite Dipsea, some farm buildings seemed to have been so disturbed as to be thrown out of plumb. They were not visited. At Dipsea 2 summer cottages were moved a few inches to the southwest, or were wracked in that direction. The hotel was swayed in the same direction, but the building withstood the shock. The barn, a rather large building, was thrown from its underpinning, falling toward the lagoon.



*Distribution.* — The variation of intensity with the character of the geologic formation is evident at various localities, but most conspicuously at Bolinas, where the destruction on alluvium at the bottom of the little valley was very much greater than on the hills immediately adjacent. Nevertheless, the data are not sufficiently full for a satisfactory discussion of this phase of the distribution of intensity, and I have therefore tried to make allowance for differences of formation, and in that way obtain a general conception of the distribution of intensity with reference to the fault and the Rift.

The intensity was greatest on the line of the fault, but did not diminish rapidly toward the east and west within the Rift belt. In a general way the intensity was greater in the Rift belt than on either side. On the east it fell off rapidly — almost suddenly — at the limit of the Rift. On the west it fell off gradually, being nearly as high at a distance of 0.5 mile or 0.75 mile from the rift as at the edge of the Rift. In a general way the intensity west of the Rift was greater than at the east. My conception of the distribution on a line normal to the Rift is expressed by the following curve (fig. 50), but this should not be subjected to measurement, as its elements are not definitely quantitative. It is a generalization from data that are heterogeneous and by no means complete.

In a general way the distribution of high intensity follows the distribution of bedrock cracks. Inverness, where the injury to structures on firm ground reached a maximum, is traversed by important bedrock cracks, some of which are to be accounted as branches of the main fault. The high ridge west of the main valley, over which the intensity was nearly as great as along the Rift, was also characterized by many important bedrock cracks, and by a general derangement of the underground circulation of water. The district east of the Rift, where the intensity rapidly diminished, was practically exempt from bedrock cracks, and its underground circulation was not disturbed.

*Notes by other observers* (R. S. Holway).—A bridge about 0.75 mile southeast of Point Reyes (toward San Francisco) went completely down, causing several days' delay to trains. The track had had several horizontal bends of a few inches.

The "fills" across the arms of Tomales Bay generally sank from 2 to 8 feet. The 1,000-yard fill about 2 miles north of Point Reyes Station sank from 6 to 8 feet; as did the next fill, which is some 500 feet long. In one or two instances the pile-supported bridge in the middle of the fill remained at grade. Just above Hamlet a trestle-work which had been filled in settled, leaving the trestle-work some 2 feet above. The bottom of the bay in these arms is usually sand.

At Hamlet quite an extensive landslide has started in the hillside above the track. The railroad cut is in old rock, and the arch of the head of the slide is some 70 feet above the track. The country wagon road has been carried away by the slide for possibly 100 yards.

Miss Margaret Keating, a teacher at Marshall's, just at the close of the earthquake saw two waves coming from the opposite side across the Bay; that is, the length of the wave was parallel to the main Rift. The waves were from 6 to 8 feet high. The waves came nearly to the top of the trestle, and also up to certain willows which she indicated, both points roughly indicating a wave of the height she mentioned.

At Marshall's a hotel and a stable built on the west side of the track and on underpinning, resting in the tidal flat, went easily and gently into the bay. The occupants of the hotel did not realize that the hotel had fallen, but at first thought the water had risen. At the post-office store goods were thrown from the west wall, but scarcely at all from the east.

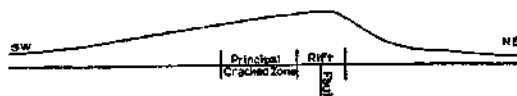

FIG. 50. — Curve illustrating distribution of intensity in relation to fault-trace and Rift. The height of curve above horizontal line represents intensity.

George H. Covert, of Cypress Grove, about 0.5 mile north of Marshall's, states that on the morning of April 18 he saw a wave 8 to 10 feet high, and white-capped, come broadside on to the east side of the bay immediately after the shock. That is, the wave-crest was parallel to the axis of the bay. The ground has a gentle slope here, and the wave did no harm. Mr. Covert gave a clear, intelligent account, and fully corroborated the testimony of the teacher at Marshall's.

The island in the bay nearly opposite Hamlet was visited, but no sign of the fault was found. Tomales Point, west of the bay, was crost at the "Gum Trees." Small landslides were found on the bay shore on the ocean side of the point at various places. On the peninsula no cracks were found. At one place on the ocean shore a projecting granitic, rocky spur was much crusht and ground in the narrow neck connecting it with the mainland. The spur is about 30 feet high and 50 feet long.

Prof. E. Knowlton gave an account of the damage caused by the earthquake at Bolinas and vicinity in the public press, extracts from which are here quoted:

Along the main street of Bolinas stand most of the houses, not far from fifty in number and all frame. Of these about two-thirds were heaved, slid, tipt, and shattered into uninhabitable condition. No fatality occurred. As in San Francisco, most of the chimneys came down, but the shock was much more severe in Bolinas than in San Francisco. Along the bay shore were 7 buildings. Of these 6 went over or down. At the Flag Staff Inn the tipping of the house has thrown it so far east into the bay that one may sit along the upper edge of the parlor floor and fish in 4 feet of water along the opposite edge of the same room. The village church was pitched forward and downward, falling 3 feet; pews were torn loose and pitched about, with walls and ceilings cracked and shattered. The large new 2-story building now containing the Post-office, 50 x 30 feet, was swung 5 feet off its concrete foundation at the north end. Back of the Steele place, near the north end of the lagoon, the hillside started eastward toward the lagoon, bulged upward, and cracked into several fissures from 30 to 100 feet long and from 5 to 18 inches wide. The great ocean bluffs along the south and west of the entrance to Bolinas Lagoon, some 165 feet high, crumbled and fell, crashing down upon the ocean beach and reducing the slope of the bluff to half its former angle. The two bluffs along the stage road from the head of the lagoon to the town also broke and fell from 40 to 60 feet, completely blocking the stage road along the lagoon beach.

#### BETWEEN THE COAST AND SANTA ROSA VALLEY.

*Tomales, Marin County.* Population 300. (R. S. Holway.) — The Catholic Church, a fine-looking stone building, was completely wrecked (plate 81D), as were the brick bank and saloon, and a stone store building. Several frame buildings were pitched from their foundations and wrecked. A brick chimney on the United States Hotel was pitched north and went over the porch, falling in the street. All chimneys were down. Cracks were reported in the street and near the depot. Just north of the depot there was an extensive landslide along the railroad, which threw one track over the other. (Plate 129 A.) hi the cemetery 18 square monuments fell north or south, 11 north, 3 south; 3 square monuments fell east or west. No monuments of any size were left standing except 3 heavy and relatively low rectangular stones. In another cemetery, 0.5 mile out of town, 20 monuments fell north and south, and none east or west. Four monuments were left landing. A small spring started in the basement of Mr. Cornett's house, which stands on the hillside near the depot. A stone dwelling 1.5 miles southeast of the town was completely wreeke.l, killing two people. (Plate 81c.) At Freeman's, 3 miles north-east of Tomales, a large landslide was caused by the shock. (Plate 129B.)

(Mr. Dftnell.)—At noon, April 17, the plaster fell in a store and broke the show-cases.

*Dillon'u Htarh* (R. S. Holway). — Chimneys were thrown from the small cottages, but one chimney on the main building remained standing.

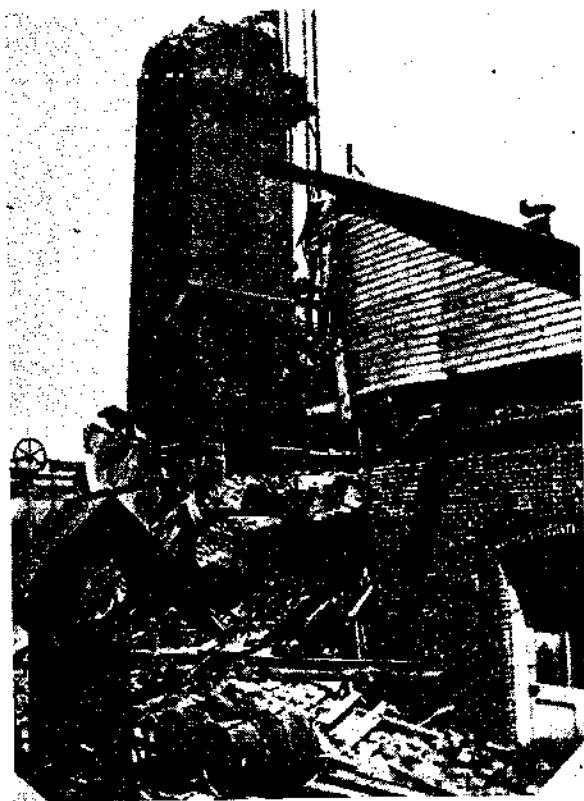

A. Cold-storage plant, Petaluma



B. Buoiuer Hotel, Willets. E. S. H.



C. Corner Main and Washington Streets, Petaluma.

*Tomales to Petaluma* (R. S. Hoi way). — Route, eastward to corner south of Two Rocks, and then southward to Walker Creek; thence eastward to Petaluma.

The stone house which fell and killed two girls is on this road, less than 2 miles from Tomales. Chimneys are generally down, but there are several exceptions. Between the lagoons (5 to 6 miles south of west from Petaluma) increased flow of spring water is reported. No cracks are reported in the low alluvial land around the lagoons nor in Chileno Valley.

*Valley Ford, Sonoma County.* Population 300. (R. S. Holway.) — There are only 3 brick buildings in the village. One entire wall of the bank fell; other walls were partially wrecked. The walls of the other two buildings were partially wrecked. A large frame house just west of town shifted from its underpinning and was badly wrecked. General loss of chimneys and minor damage to small buildings resulted from the shock. There are quite a number of cracks in the flat valley-bottom adjacent. A landslide of several hundred yards in length but of very slight movement is found on the side of the valley directly east of town. The slide has moved just enough to make a furrow-like ridge on the lower side and has developed cracks on the upper side. Other small slides occur in the vicinity.

(H. M. LeBaron.)—Valley Ford is about 25 feet above tide water, and there are rocks near the surface in many places. Chimneys and objects were thrown north and south; the motion of the shock was north and south; and no vertical movement was felt. Brick buildings were partially destroyed, and many chimneys were thrown down. The foundations of many wooden buildings were damaged, some foundations giving way entirely. A large, well-built wooden residence of two stories was thrown to the south 3 feet and to the east one foot, and caused to drop down 3 feet.

*Bloomfield, Sonoma County.* Population 200. (R. S. Holway.) — This village is on the north side of the little valley running eastward from Valley Ford. The 3 brick buildings, two stores and a dwelling, were wrecked. Every chimney but one reported down. Several frame buildings shifted on their foundations. The cemetery is very badly wrecked; about 80 per cent of the larger stones fell. Of square monuments of approximately the same class, the direction of fall was north 11, west 14, south 8, east 0, south-east 1, total of this class, 34.

*Bodega, Sonoma County* (H. C. McCaughey).—The town is on a hill slope and creek-bottom in a valley surrounded by hills. Chimneys and objects were thrown southerly. Several houses were shifted on their foundations, and all chimneys were thrown. Good frame buildings with strong foundations were not hurt. There are no brick buildings in the place, but a mile from town there is a brick bark-drier. Altho this building is small and the brick work was bound together with iron rods, it was thrown into a heap.

#### SANTA ROSA.

In the section of the Coast Ranges inland from the coast, between the latitude of Healdsburg and the Bay of San Francisco, Santa Rosa first claims attention. This city, with a population of 6,700, suffered relatively more than any other place in California, except perhaps Sebastopol and Fort Bragg. Prof. R. S. Holway made a study of the effects of the earthquake at Santa Rosa and the surrounding territory, and an excellent report by this observer follows:

Santa Rosa lies on the eastern side of Santa Rosa Valley, which is here some 7 miles wide. The valley floor is a gently sloping alluvial plain with an average elevation of about 150 feet within the city limits, falling with a slight grade to the swampy lands adjacent to the Laguna de Santa Rosa, which runs close to the foot-hills on the west. The elevation at the Sebastopol railway station is but 68 feet above the sea.

Santa Rosa itself is on a low-grade alluvial fan which heads in a narrow gap in the foot-hills bordering the town. This gap connects with a basin of some 40 square miles, which empties its drainage on to the Santa Rosa fan, in a stream that formerly shifted its course over the slopes. Old channels are still to be found in places, altho they are usually filled by the grading for streets and buildings. A bridge formerly crossed the main channel on Tenth Street, near Mendocino. The approximate course of this channel is shown for a short distance on the accompanying map, No. 16. The present course of the creek was adopted but recently, according to the testimony of early settlers. The wells in town are shallow, and none were reported that had been sunk thru the alluvial deposits to bedrock. With these physiographic conditions, it will be seen that the alluvial fan upon which the town lies must have been filled nearly to the surface with ground water during the early springtime. The physiography of the vicinity is one of the factors to be considered in discussing the great destruction which was caused in Santa Rosa by the recent earthquake.

The shock of April 18 and the ensuing fire caused a loss of life of 61 identified dead, with at least a dozen "missing," and practically destroyed the business portion of Santa Rosa. (Plates 74, 75, 76, 77, 78, 79.) The equivalent of some 7 to 8 blocks was destroyed by the earthquake, and from 4 to 5 blocks by the fire. Conflicting reports are of course given as to the extent of earthquake damage in the burned district. The insurance companies have worked without any joint commission and no data were obtained from their agents. Judging from the unburned blocks adjacent, the buildings in the burned area were badly wrecked. One man told me that a book-store — Fourth Street, between Mendocino and B Streets — was not badly hurt by the quake and that he was in the lower floor and there was not much damage. In continuing his story, he stated that people were burned to death in the upper story of the same building because they were so caught in the debris that they could not be extricated.

The accompanying map (No. 16) shows the areas destroyed by the earthquake, and by the fire, as plotted in the office of the county surveyor, Mr. Newton Smyth. Other business men have since examined the map and agree to its substantial accuracy.

The residence portion of the town suffered to quite an extent. Chimneys were generally thrown down or so badly cracked as to necessitate their rebuilding. From twenty to twenty-five residences were thrown to the ground by the collapse of their underpinning, and badly wrecked. In cases which I personally inspected, houses close by, on ground apparently just the same, were but slightly damaged. The difference seemed to be in the character of the structural work. No uniform direction of fall was found in the wrecked residences. The reports of residences thrown "so many feet" were accounted for on investigation by the height of the underpinning which evidently determined the amount of motion. The accompanying photographs are illustrations. Thruout the town there were numberless minor injuries to plaster and fragile articles.

The physiographic results of the shock seem to be confined to some minor cracks in the vicinity of the cemetery with the possible addition of some small cracks near the creek bed adjacent to the tannery, as given in the detailed report below:

Mr. J. C. Parsons, city engineer, reports that he has found no changes in alinement since the shock. He thinks there are no changes in level, but has not yet made any accurate measurements of level. No disturbances of streets or sidewalks were found, such as are common in San Francisco.

Below are some detailed reports obtained from residents of Santa Rosa and vicinity. Few people on the street at the time of the shock were so situated as to make any valuable observations of the immediate and direct results of the earthquake.

Mr. J. W. Brown was living on Tupper Street, between Main and Brown Streets, about 5 blocks southeasterly from the court-house. His testimony is of value, as he was not distracted by any destruction of buildings in his immediate neighborhood. He was up at the time of the first shock and went outdoors to see if he could notice any waves in the ground, earthquake waves having been a subject of discussion with him in recent conversation. On going outside he heard a great noise from the west and saw the treetops waving. The noise and motion of trees approached him, and he took hold of a small tree near by for support. This tree was torn from his grasp. The ground seemed to be in waves "about 2 feet high and 15 feet long." Looking toward the court-house, he saw the dome swaying west and east, "maybe north of west," more or less in line with him, he added. The dome fell with about the third swing which he noticed.

Mr. Green Thompson was engaged in street sweeping at the time of the shock, and first heard a rumble like a wagon going over cobble-stones. He ran around the corner (Third



Santa Rosa.

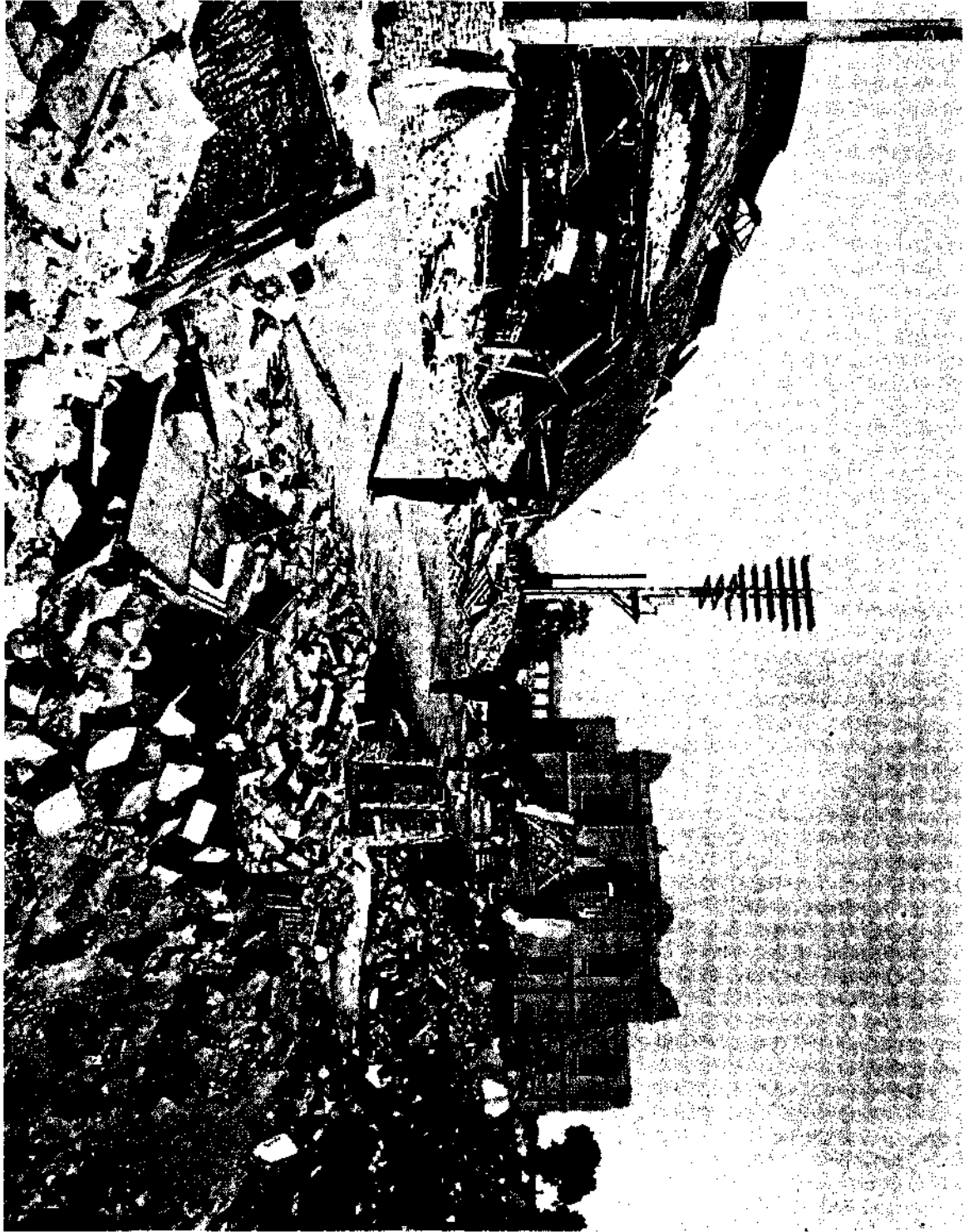



Santa Rosa.



and Main Streets) and stood in the street between the Grand Hotel and the court-house. He states that he saw the dome swinging southeast and northwest, tho later in describing the motion he added that it was swinging up and down Third Street, which runs south of west and north of east. "With the last swing the ground came up short and stopt," and then the building fell. "All the buildings fell at once; no one first." The dome of the court-house fell east. Down Fourth Street the dust was so great that he could see nothing. He is sure that he heard but one crash.

In general, inquiries as to direction of fall of buildings met no definite answer, or else the answer was very definite with no indication of good observational basis. Many told me that there was no direction of fall; that the buildings simply crumbled to the ground.

The Masonic Temple and the Theater, I was told, fell so directly downward "that the debris did not extend beyond the walls 10 feet in any direction." This was substantially my observation on passing thru the ruined district on May 1.

Mr. M. W. Keithby, the watchman at the tannery, F and Second Streets, says that the liquor in the vats was thrown straight up and then splashed out on all sides. The tanks tipt to the west. A 3-story frame shoe factory on the north side of the tannery grounds went completely down — being flattened with but little direction of fall. One of the foremen said that the fall was slightly to the north and that heavy machinery was found close to the north wall on the third floor.

A teamster working in the creek just south of the tannery says that he noticed cracks an inch wide and several rods long a few days after the shock. He "thinks the cracks were not there before."

Mr. Searey, a teacher in the High School, stated that the vibration was east and west. In describing the shock, he stated that in coming thru a doorway facing west, he was thrown against the north casing.

A rather large 1-story frame building on Eighth Street with a brick and stone foundation was shifted N. 3° W. On A Street, near Fifth, a cottage fell to the south. The house at Johnson and Mendocino Streets fell to the north, while of the two houses at Mendocino and College Streets, one fell southeast and the other north. On Fourth Street, near E, a residence fell to the east. On MacDonald Avenue, Mr. Weaver found two houses that fell to the north. The lack of harmony in the direction of fall, and the short time, prevented an investigation of the direction of fall of all the residences wrecked.

The main Santa Rosa Cemetery, just beyond the city limits on the northeast, was badly wrecked, but not to such a degree as the cemetery at Sebastopol. The direction of fall of monuments was carefully noted, but no indication of regularity resulted. Of square monuments of approximately equal size and conditions, 12 fell north, 10 south, 7 east, and 13 west. (See plate 80A, B.)

The most marked physiographic effects in the vicinity of Santa Rosa were found near this cemetery. Just north of the cemetery hill is a swampy depression. Part of this settled 2 or 3 feet with the formation of a crack along the side, extending for some 200 feet. The cemetery is on a low hill which the sexton reports as being sand, gravel, and clay, but which shows a rocky outcrop, on the eastern side, near the base. A crack an inch or more wide was found on the northern end of the hill near the swamp mentioned above. This crack could not be followed for more than 100 feet, altho the sexton reports that at first it extended 2 or 3 times that distance. A small water-pipe on the southern part of the hill, running north and south, was pulled apart. A pipe on the northern part of the hill, running east and west, is reported by Mr. Weaver as pulled apart about 4 inches. On the southwest of the cemetery hill, Mr. John Livsey reports that several fine cracks formed across the road running north and south, and that the dust was blown away near the edges of the tracks. He also reports that the trees along the road were swinging very definitely in line with the road, which here runs northwest. The only other physiographic effects found were at the County Hospital, a little more than a mile north of the cemetery. Here low ground at the foot of a small hill sank for some 2 feet and springs were formed. These springs were reported as still running the last of July. No connection could be found between the disturbances at the cemetery and the hospital. In the cemetery a large tank fell to the north. The tank was close to the water-pipe that was pulled apart on the north and south line.

At the Catholic Cemetery, some 2 miles southeast of Santa Rosa, only one monument fell out of some 20 of the class that were commonly overthrown at the main cemetery. Going farther southeast thru Bennett Valley, no physiographic effects were discovered and few chimneys were thrown down.

Not knowing of Mr. Butler's trip to the southward, I duplicated part of his work to the south of Santa Rosa, on the Petaluma road, with the same results as stated in his report.

Up the alluvial slope of Copeland Creek about 7 miles south of Santa Rosa, I found that chimneys were much more damaged than on the road northward from the creek to Santa Rosa, which usually follows the edge of the foot-hills.

Northeast of Santa Rosa, Mr. Butler reports that along the road to the Rincon District the damage was very slight, as it was also on the road running northwest from Santa Rosa toward Fulton. This road, it should be noted, keeps close to the foot-hills.

The most severe damage in the country around Santa Rosa was found to the westward in the vicinity of Sebastopol.

The great damage in Santa Rosa may be accounted for by the physiographic conditions and by the weakness of the buildings in many cases. The sand for mortar has usually been obtained from the creek and contains considerable loam. Some of the mortar seems to have been made with good sand and with cement. The old bank building, just west of the court-house, stands alone in that part of the wrecked area, a monument to good work. Usually throught the wrecked area the mortar taken from the walls is easily crumbled to incoherent sand by pressure of the fingers.

(E. C. Jones.)—Very little damage was done to the gas mains in Santa Rosa as a result of the earthquake, but there were several explosions in the mains during the fire which followed. In several cases the cast-iron mains were blown apart; and when uncovered, the ends were found to be separated from 1 to 3 inches, according to character of ground.

At the generating plant the damage was principally to the brick building. The entire east wall fell outward, and the remaining walls were badly cracked. The columns of the gas-holder frames were thrown down, and the water-level in the tank was lowered about 6 feet. The holders were twisted out of position about  $20^{\circ}$ .

(C. T. Wright.)—There seem to have been two distinct motions in Santa Rosa, one from north to south, or more properly from north  $30^{\circ}$  west to south  $30^{\circ}$  east, the other roughly from west to east. The former motion seems to have been noticeable over a larger area and probably was the more violent. There is a belt along the Northwestern railroad tracks in which the west-east motion was specially noticeable, as shown by observations at the flour mill, the woolen mills, and the cannery. West of this belt, at the tannery on West Sixth Street, a distinct north-south, or northwest-southeast, motion was indicated, while east of this belt, in the region from Washington Street to A and B Streets, the northwest-southeast motion was specially evident and is the predominant motion. At Humboldt Street it becomes somewhat confused.

Most reports agree as to "choppy," rotary, or up-and-down movements following the pronounced horizontal movement, or between successive horizontal movements. This suggests interference of waves. The observed phenomena might be explained by the passage of a series of long, very rapid northwest-southeast waves of great intensity; and simultaneously or immediately following the beginning of this series, a second series of comparatively short west-east waves. Supposing the crest of the latter to have reached a line in the neighborhood of Washington, A, and B Streets, and the trough of this series to be near the Northwestern railroad tracks when a crest of the northwest-southeast series swept down, the two motions would tend to neutralize each other in the neighborhood of the railroad tracks and augment each other in the other district. It may be supposed that after the passing of this northwest-southeast crest and before the passage of another, the west-east waves were specially noticeable near the railroad tracks and did their destructive work there. If this theory be correct, another "trough" should be found between Mendocino Street and the Southern Pacific railroad station. The somewhat promiscuous directions of falling objects on Humboldt Street might indicate the approach to this region. To test the theory would require further observation.

(Marvin Robinson.)—Mr. Robinson of Santa Rosa states that he was just across Fourth Street and north of the court-house, and that at first the dome of the court-house seemed to be almost over him, and a few seconds later fell directly east. The brick buildings near him all fell east. He believes the street to have been vibrating in a vertical direction at the close.

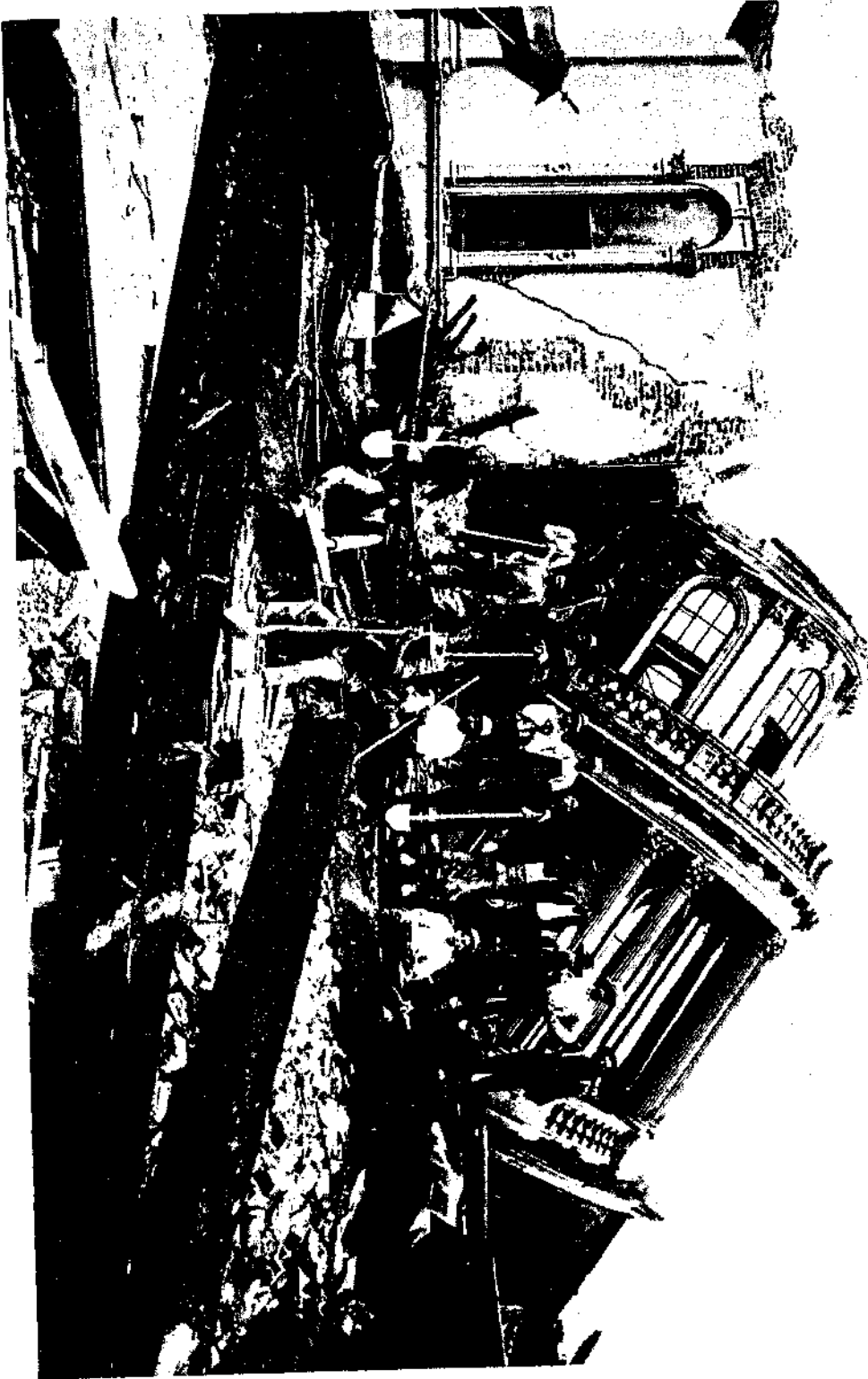

City Hall, Santa Rosa.



A. House moved 7 feet by collapse of underpinning, Santa Eosa. E. S. H.

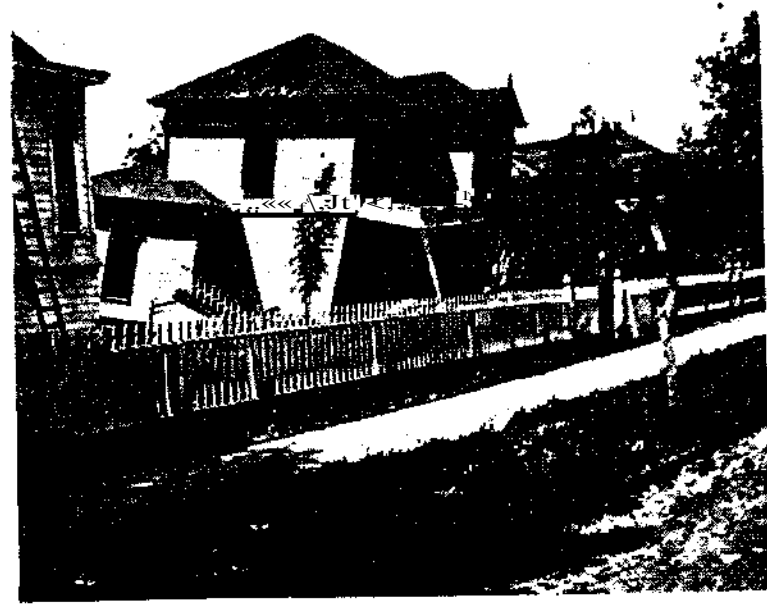

B» House lurched to north, Santa Eosa. B» S. H.



C. Wrecked dwelling, Santa Eosa, E. S. H.

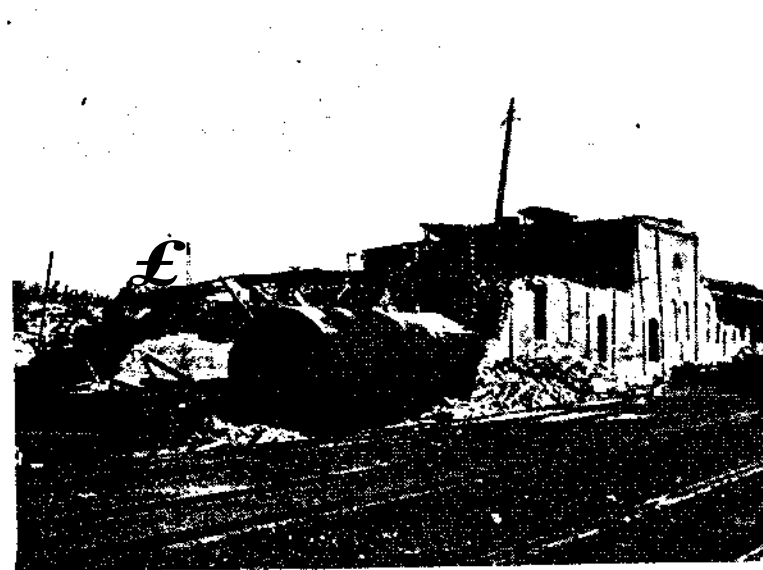

D, Wreck of brick structure, Santa Eosa. E. S. H.



A. Cemetery, Santa Rosa. R. S. H.



B- Cemetery Santa Eosa. E. Si H.



C. Cemetery, Sebastopol. E. S. H.

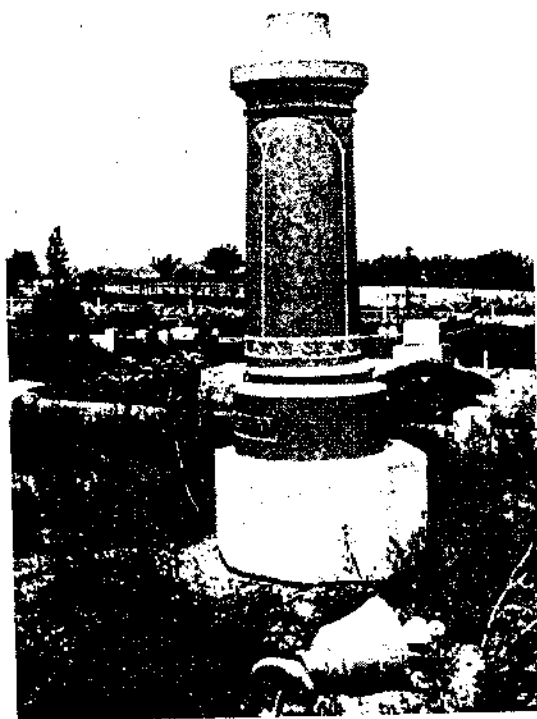

D. Cemetery, Sebastopol. E. S. H.



A. East side of main street, Sevastopol. R. S. H.

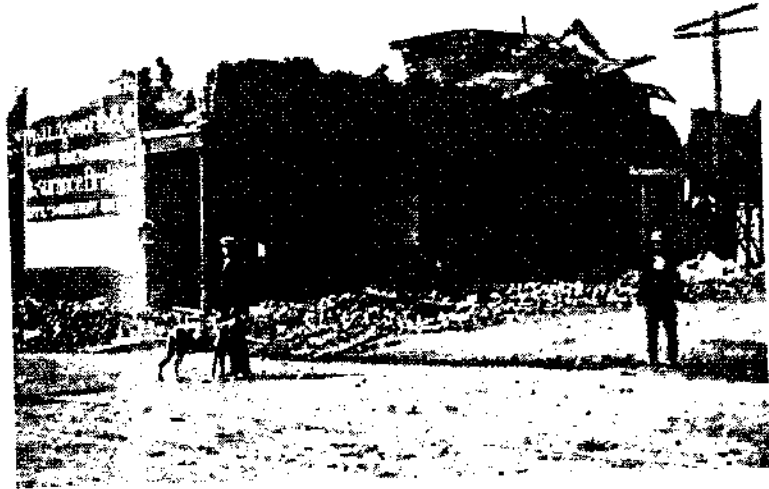

B. Wrecked buildings, Sevastopol. E. S. H.

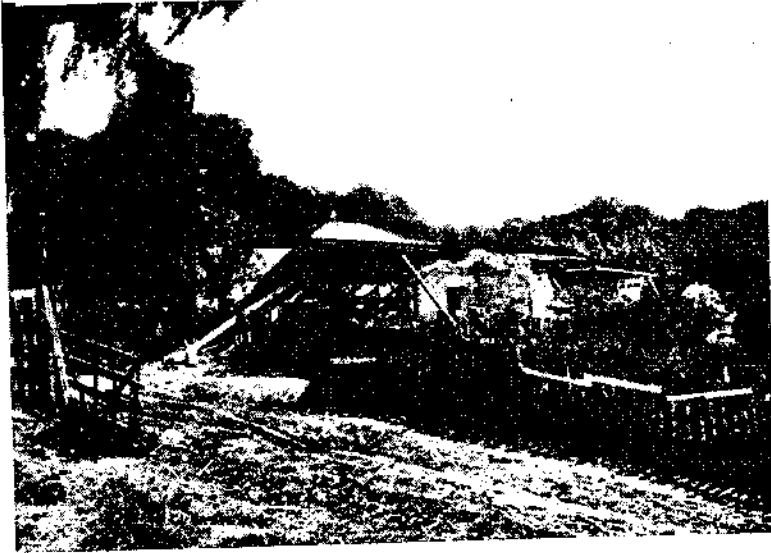

C. Stone house 1.5 miles southeast of Tomales, where two people were killed at time of earthquake. E. S. H.

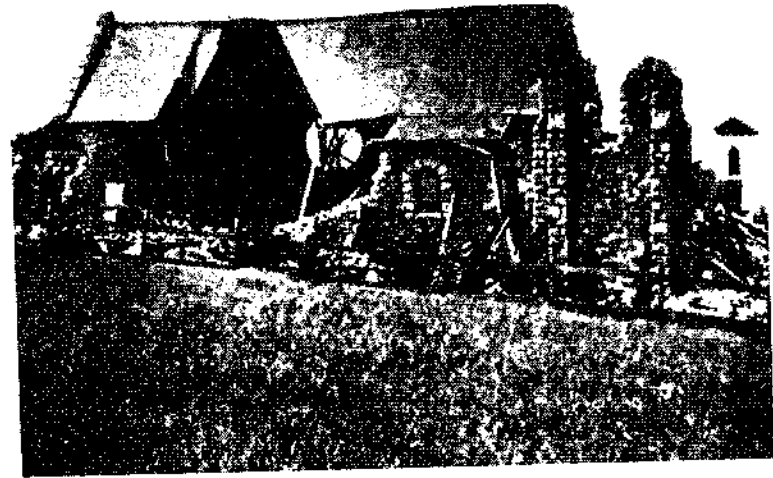

D. Wrecked church, Tomales. E. S. H.

(Charles Kobes.)—The vibrations in Santa Rosa were at first north and south, then east and west, and finally vertical. Mr. Kobes relates an instance in regard to the earthquake which occurred about 8 years ago. At that time sulfur fumes came up from under his house which almost drove his family from home. On April 16, two days before the shock, sulfur fumes came up equally as strong, and he told his family that he believed it meant another earthquake.

(Mr. Miller.)—The vibrations in Santa Rosa were at first north and south, then east and west, and finally vertical.

#### VICINITY OF SANTA ROSA.

(Drury Butler.)—Near the top of Taylor Hill, in a marshy place, there was a landslide, the earth having slid on a clayey bottom. In Bennett Valley the country is hilly, with some underlying basaltic formation, and very little damage was done. Beyond a distance of about 3 miles from Santa Rosa, only an occasional chimney was found that had been injured, and the effect was much less as higher ground was reached. Along the Sonoma road to the Rincon district school, beyond 2 miles from Santa Rosa, the damage was very slight. The road follows the creek, but here the hills come down to the creek. Over half the chimneys were uninjured, and none were completely thrown down except right along the creek. No bottles nor glasses were thrown from the bar-room shelves. Along the creek the shock was more severe than back from it. In the vicinity of the Sonoma County Hospital, the soil is very like the Santa Rosa soil and the shock was felt more. Glasses and bottles were thrown from the shelves in the bar-rooms, and at the hospital a marshy place along the creek slipt toward the creek and the flow of springs was greatly increased. The hospital also was pretty badly damaged. A trip was made out on the Petaluma road to the Copeland district school, then to Cotate, to the Durham district school, and back to Santa Rosa. The road followed the base of the hills for about 7 miles, then turned into the valley and was on the valley floor the remainder of the way. On the hillside very little damage was done, even to chimneys, while in the valley the chimneys were as a rule thrown down. I could hear of no cracks in the ground in the valley; and in only one place, about 2 miles from Santa Rosa, on the Petaluma road, could I hear of any increase or change in the flow of springs.

From these observations it was apparent that lines of equal intensity would follow the contour and geological lines of the country, and that the character of the soil on which a building stood determined the effect upon it, or the apparent intensity of the shock.

The general motion of the waves of the earthquake, as reported to me, was from north to south.

*Cotate* (C. L. Jeffrey). — At Cotate, 9 or 10 miles south of Santa Rosa, on the open level floor of the valley, the surface of the earth waved like water; objects were thrown southeast; hanging objects swung northeast and southwest. Only one maximum was observed. Trees swayed heavily, and there was a sound as if a strong wind were coming before the earthquake began.

*Wells East of Santa Rosa* (E. S. Larsen). •—At the city pumping station, 1.5 miles east of Santa Rosa, there are 4 wells dug 50 feet and connected with a tunnel 450 feet long. Within each well there is a bored well 8 inches in diameter and 108 feet deeper than the dug well. The water began to rise immediately after the shock, and has risen, May 8, 1906, 15 feet higher than it was before, altho the pumps have been run to their full capacity. The water tastes more of sulfur since the shock. The shock caused the pipes and boiler to leak.

At Peters' ranch the warm spring was little affected. Mr. Peters, the younger, says that for a day or so after the shock the water in the spring was lower, but that it is now normal.

*Sebastopol, Sonoma County.* Population 1,300. (R. S. Hoiway.) — Several buildings were completely wrecked. (Plate 81A, B.) The 2-story Knowles Hotel, a frame building, veneered with brick, went completely down, flattening the first story. The walls of the hotel fell out, so that the occupants of the rooms in the second story walked out on the ground level. The upper part of a brick stable was wrecked; also the upper part of the Walker Building, which is to the north in the same block. Three stores just south of the post-office were completely wrecked. North and south side walls both fell south, one falling out, the other into the building. The contents were badly scattered. A new frame house, a 2-story structure, was moved from 3 to 8 inches on the concrete foundation and the walls were cracked and wrenched.

The cemetery, about 0.7 mile west, is more severely wrecked than the Santa Rosa Cemetery. Nearly 90 per cent of the monuments of any size were thrown down. (See plate 80c, D.) The great majority of square monuments fell south. The heavy Talmage monument was moved southeast on its base. The sheet lead under the southeast corner shows one set of regular striae; the lead under the north corners is untouched. Cracks occur in the ground near the cemetery and near the Burbank ranch.

Mr. R. M. Hathaway, writing from a place 3 miles northwest of Sebastopol, sends the following information:

Many frame buildings in the vicinity were thrown from their foundations and some of them so damaged as to be uninhabitable. Chimneys were all shaken down, also brick furnaces. There are no brick buildings around here. The earthquake at my point of observation seemed to have an oscillatory motion, the vibrations traveling north and south. My house is a two and one-half story frame building on a low ridge of sandy hills running north and south, west of and parallel to the Santa Rosa Valley. All objects seemed to have a tendency to move toward the south. All furniture against the north walls was thrown down violently, some on the south wall going down also; while some remained upright as tho supported by the wall. Furniture against the east and west walls was moved toward the south.

The chimneys all fell to the south. Window casings on east and west walls were wrenched so as to break some glass. Injury to the frame houses in the vicinity, apart from damage due to falling chimneys, seemed to consist in throwing them from their foundations, and where a house consisted of several portions in the form of wings, these were separated. The foundations in some instances crushed, letting the buildings down to the ground. Well-constructed frame buildings, where the foundations were low, did not collapse. At the Sebastopol Cemetery, about a mile west of Sebastopol, the monuments were nearly all overthrown, falling in all directions, altho I estimate that fully half of them, if not more, fell to the south. I did not notice any change in water level, the change if any being small. There were some fissures made in the ground near here.

President David Starr Jordan contributes the following note relative to the effects of the earthquake at Sebastopol:

The violence of the recent earthquake was very great at Santa Rosa; much less at Petaluma, which is equally near the crack and on still flatter ground; and still less at San Rafael farther south but the same distance from the earthquake Rift. At Sebastopol, 6 miles west of Santa Rosa, the violence was relatively still greater, the village being tremendously shaken up. At Burbank's farm, 0.5 mile west of Sebastopol, I noted these things: In the lot adjoining, to the south, the soil being clayey, there is a large crack running northwest and southeast, or nearly so, and, according to Burbank, 0.25 mile long. It runs thru the fields and weeds, and was very distinct on August 6. The end of this crack comes up against the sandy hill occupied by Mr. Burbank's orchard. The crack does not show itself in the hill, but on the east side of the line of the crack the rows of trees and plants were shifted toward the south — or, if you prefer it, those on the west side toward the north — 2 or 3 feet. A well of Mr. Burbank's, sunk in the sandy ground, is bodily shifted, without being injured, along with the rows of plants between which it is placed. No crack appears at the surface in Burbank's ground, but on the other side of the hills, to the north of it, I was told the crack reappears.



According to the record of Matthes and Holway, similar cracks appear in the same line 4 miles and 9 miles north of Petaluma, and there seem to be other breaks on the way toward Point Delgada. It seems certain that this first crack is an earthquake rift, and that the disturbances at Santa Rosa and Sebastopol are due to this and not to the main Rift which lies parallel to it to the west.

Mr. G. K. Gilbert also visited the Burbank farm at Sebastopol, and contributes the following note referring in part to the cracks discuss by President Jordan:

Mr. Luther Burbank gave me an account of personal experiences and of various phenomena at Santa Rosa, and I record such items as are supplementary to Professor Holway's report. Mr. Burbank was awake at the time. He immediately got out of bed, but found he could not stand, and settled back against the bed, holding on to the window casing and bedpost. The initial impulse was from the west, and during the first portion of the earthquake the motion was oscillatory, east and west. Then it became oscillatory north and south, and at the close there was a complex motion which he compared with that of a vessel in a choppy sea. From the window he saw trees waving, and after the tremor had ceased he seemed to see a continued disturbance in the foot-hills at the east, as tho the tremor was retreating in that direction. He said that practically every one in Santa Rosa who was on foot at the time was thrown to the ground, but that men on bicycles were not upset. During more than 30 years' residence in Santa Rosa he had felt about 130 earthquakes. None were comparable in violence with the recent one, tho several had broken chimneys. A number of earthquakes which were felt generally in Santa Rosa had not been felt at all in Sebastopol, and he thought that Santa Rosa was peculiarly subject to shocks.

A shock was felt in Santa Rosa on April 17, 1906.

Mr. Lawrence, foreman on Mr. Burbank's farm at Sebastopol, stated that men standing or walking at the time of the shock were thrown from their feet, as were cows and horses. The small house on the Burbank place was moved from its foundations a few inches downhill, and Mr. Lawrence mentioned a number of houses which had moved various distances, the direction in every case being downhill. On the Burbank farm a small landslide occurred, a layer of moist soil only a few feet in thickness moving down the slope, introducing bends in various lines of cultivated plants. I saw another feature of this sort on an adjacent farm, and was told of others which I did not visit.

In a general note on the intensity of the earthquake, appended to detailed observations which have been incorporated in the foregoing account of the distribution of intensity, Mr. G. K. Gilbert says:

In general the violence seems to have been less in Petaluma than in Sebastopol, Santa Rosa, or Maacama, notwithstanding the fact that it is nearer the main fault. As compared with Sebastopol and Santa Rosa, however, Petaluma seems to be on relatively firm ground, excepting a small district bordering the marshes. In a general way, I think the relative violence in the three towns corresponds to the character of their foundations, but considering the district as a whole, in relation to districts nearer the main fault, it is clear that the intensity was exceptionally high.

*Altniria, Sonoma County* (R. S. Holway).—About 5 miles north of Santa Rosa, at Altruria, cracks are said to have opened in the road, and springs to have flowed for a short time. There was no indication of either last May.

*Mark West Springs* (R. S. Holway).—The concrete walls of several springs were cracked and damaged. Chimneys fell on the house. The springs are reported as flowing much more freely, and the temperature of two of them is said to be very much higher than before the earthquake. They are now quite warm to the hand, and it is said that they were formerly cold. I could get no reliable information as to temperatures, as no records were kept. The increased flow is independently indicated by circumstantial evidence.

*Windsor*. Population 130. (R. S. Holway.)—Here 2 or 3 brick buildings were badly wrecked, and the water-tank at the railway station was overthrown. The cemetery

about 1.5 miles south of Windsor is on low, rolling hills. Only 4 monuments out of 35 to 40 of the class wrecked at Sebastopol and Santa Rosa were thrown down.

*Guerneville.* Population 500. (R. S. Holway.) — In this town all brick buildings were badly wrecked. Chimneys generally fell. The Commercial Hotel, a frame building, was twisted slightly, contraclockwise. Under the house of Mr. Turner, which is built on piles, the piles on the east side were thrown 8 inches east and those on the west side 4 inches north. Mr. Turner reports the shock as clearly from north to south. His workcases were thrown from north to south. The cemetery, which is on a terrace 190 feet by aneroid above the flood plain on which the town stands, was very slightly affected. One monument is reported to have fallen. Three or four show slight shifting.

#### SANTA ROSA VALLEY TO SAN FRANCISCO BAY.

*Petaluma.* Population 3,900. (R. S. Holway.) — The inspector of chimneys reported that the great majority of chimneys fell. (See fig. 64, page 341.) In east Petaluma, on the lowland, all but 4 fell. Three brick stores had the entire front thrown out, and 10 or more had tops of fire-walls thrown down. The stone hay-barn of McNear was wrecked; also a corner of the stone warehouse. The 2-story brick silk factory had every corner wrecked. The central tower and the large brick chimney were thrown down. The ice plant near the station had the high brick stack thrown, wrecking part of the building. The Golden Eagle, a 4-story brick flour mill, was not damaged; but the 1-story addition and a 1-story stone warehouse had portions of their walls fall. There are no authenticated reports of cracks in Petaluma nor in the low tidal lands immediately adjoining. Vague reports to this effect were not verified. (See plate 73A, C.)

*Lakeville, Sonoma County* (C. A. Bodwell).—This place is about 6 miles southeast of Petaluma, on a hill slope near the tidal marsh of Petaluma Creek. Chimneys were overthrown, plastering badly cracked, and dishes broken. Chimneys and objects were thrown to the southeast. There were 2 maxima in the shock, of which the second was the stronger. The movement was from southeast to northwest.

*Petaluma northward up Sonoma Mountain* (R. S. Holway). — Northeast about 2 miles across the low land, chimneys were thrown down and furniture was moved. No cracks were reported in the ground. Thence northward to an elevation of over 1,800 feet, nearly all the brick chimneys were down. Houses are usually small 1-story frame buildings. Articles were reported thrown from the shelves and furniture moved. "House shaken so severely I could not walk across the floor," was a common statement. No landslides were reported, altho quite a number occurred in this region during the winter.

*Petaluma to Sebastopol* (R. S. Holway). —A drive along this road, which keeps near to the western line of Santa Rosa Valley, showed an increasing intensity of shock from Petaluma toward the northwest. Chimneys were quite generally down along the entire line. At Jur's ranch, about 2.5 miles northwest, 3 cracks with a very slight dropping of small blocks between them, are reported. A temporary flow of water was reported from a crack by the road. Small cracks were reported on the road about 4 miles from Petaluma. Near Stony Point school-house, about 9 miles out, 19 cracks across the road were reported by the teacher. At Nason's ranch there is a landslide of the bank of the lagoon 100 yards or more in length. Four miles from Sebastopol is another landslide at Davis' ranch, where a house was thrown from its underpinning. Cracks were reported at Hansen's and several places. There is a distinct increase in cracks and landslides in the approach to Sebastopol.

*San Rafael, Marin County.* Population 3,900. (R. S. Holway.) — "Half the chimneys down" was a frequent report. Most of them were rebuilt at the time of my visit. "A. W. Foster's place, on the hills to the north, had 100 chimneys and only one fell." A brick

building one block north of the station had the top of the end wall thrown down. A 3-story brick hotel was very slightly cracked. On May 1 the town showed no sign of earthquake to the casual observer. A crack one block long, north and south, in low land near the station is reported. At the Hotel San Rafael 2 chimneys fell on the roof and porch. At the cemetery, 2 miles north of San Rafael, only 3 monuments and some 8 crosses fell. Mr. Weaver reports that on 12 houses near the station and the Hotel San Rafael chimneys fell east. My own inquiries up town were generally answered by "all directions," so far as chimneys were concerned.

San Anselmo Theological Seminary is a etone building on a rocky knoll, not tied by rods. The tower of the library fell, part of it crashing thru the roof to the first floor. At the dormitory the coping on top of the walls and the chimneys have fallen on all sides of the building.

Mr. Frank M. Watson reports the following effects of the earthquake in San Rafael:

In the drug store of Mr. Inman, Fourth and C Streets, hundreds of bottles were thrown from shelves running east and west, and bottles on shelves running north and south were thrown parallel with the shelving.

At St. Paul's Church, Fourth and E Streets, the chimney moved 0.375 inch bodily to the south, and bricks were crushed out on the north side. A chimney to the west of this was overthrown. The Grammar School, west of this church, had 2 chimneys down. The High School to the south suffered no damage, but bottles moved on a shelf mostly to the west.

At the house, 17 Fourth Street, on level land, the occupants felt 2 shocks with a very short interval between, the first being longer and lighter than the second. The general direction of movement was thought to be east and west. The chimney fell east. The clock stopt. The shock was lighter on the rising ground to the south, as inferred from less damage to chimneys in that direction.

At the house of Mr. W. Robertson, 20 Fourth Street, on level land, an up-and-down motion was experienced. The middle portion of the shock was the heaviest, and it was then that a marble mantel fell east.

At the building occupied by Mr. George D. Shearer, 306-310 Fourth Street, on level land near the depot, there is a crack running north and south; 4 chimneys fell west and 2 east on a flat roof. The north end of a wall of the building fell out down to the level of the second-story floor. The coping on north and south walls fell off, and plaster was badly cracked on inside partitions. In the adjoining house, Mr. Joseph La Franchi was awake, his bed lying east and west. The shock was north and south. The chimney from the next building crashed down thru his house.

At the office of the Western Union Telegraph Co., 608 Fourth Street, a clock facing the east stopt at 5<sup>h</sup> 13<sup>m</sup> A. M.

At the jewelry store of Mr. J. D. Bennett, 709 Fourth Street, on level ground, 2 large accurate pendulum clocks hung 10 feet apart, one on an east wall and the other on a west wall. One stopt at 5<sup>h</sup> 12<sup>m</sup> 35<sup>s</sup>, the other at 5<sup>h</sup> 13<sup>m</sup>. These clocks do not vary 3 seconds in 24 hours, and were right at noon of the previous day.

At the Grand Central Hotel, 720 Fourth Street, on level land, an up-and-down motion was felt, then an oscillation from east to west. The building, built of brick in 1860, is 3 stories high. It shows a crack 0.5 inch wide in the east wall, extending from the roof to the second floor, and there were also cracks in the south wall over the windows. Some plaster fell and one chimney was broken.

At the house of Mr. George L. Richardson, county surveyor, on Harcourt Street, on level land, 2 shocks were experienced; the first apparently heavier than the second, both being of about the same duration. The oscillation was from east to west. No damage to residence. At his office in the court-house, the marble back of a washstand was thrown west, and plaster was cracked on east wall.

At the house of Mr. L. Armstrong, 206 Ross Street, on a hillside 50 feet above sea-level, milk and cream slopt from pans a little north of northwest. There was no damage to buildings or chimneys in the neighborhood. A slackening in violence was noticed about the middle of the shock.

At the San Francisco and North Pacific railroad depot, on level land 7 feet above sea-level, the night operator, Mr. Vernon Grisham, reports first an oscillation, then an up-and-down movement. Buildings shook for 2 minutes by the watch in an east and west direction.

The clock stopt at 5<sup>h</sup> 12<sup>m</sup>-30. It does not vary 2 seconds in 24 hours, and is set daily by telegraph. A crack was formed in the ground 100 feet long, running north and south. The greatest damage was half a block north of the depot. The depot itself suffered no injury.

At an unoccupied house on D Street, opposite Ross Street, a chimney moved 1 inch west and twisted clockwise about 5°. A second chimney moved bodily westward 0.75 inch, and was similarly rotated. All the chimneys in this vicinity were down.

At the grocery store of E. Kolepka, First and E Streets, a 2-story brick building, all 4 chimneys were cracked but left standing. Goods in the store were thrown from shelves running north and south, and to a less degree from shelves running east and west. Some plaster fell from the ceiling, and all chimneys in the neighborhood were damaged or thrown.

Mr. W. Robertson, city inspector of chimneys, reports that there are 1,200 chimneys down and many more damaged. Probably 100 were twisted, the amount and direction of the twist being quite variable. Most of the chimneys, however, fell northeasterly. On the hills the shock was lighter.

At Scheutzen Park, 1.5 miles east-southeast of San Rafael, on land 7 feet above sea-level, 2 shocks were felt: the first light and long, the second hard and short, the direction of movement being east of north. There was no serious damage to buildings or chimneys, but water-pipes were broken, and there were many small fissures in the neighboring ground, running north and south.

At the Catholic Cemetery, 2 miles north of San Rafael, on rising ground, an up-and-down movement was experienced. A clock in the house of the guardian tipped over, but no damage was occasioned to buildings. There were 3 monuments and a few light crosses overthrown in the cemetery. The chimney of the brick yard, a mile to the east, remained intact.

At the residence of Mr. C. Day, near the San Anselmo Seminary, the east chimney was twisted clockwise 10°; and the chimney on the church next door was affected in the same way. Things on the walls fell east. One chimney fell west.

*Novato* (F. M. Watson). — Town is situated on sloping ground. Mr. A. Scott states that 2 shocks were felt, the first east and west and light, the second north and south and heavier. In the grocery store canned goods were tipped south on shelves running north and south. Chimneys as a rule were not damaged, but the top of Mr. Scott's chimney moved 1 inch to the southwest. Two clocks were stopt.

*Samalito* (F. M. Watson). — Nearly all chimneys were thrown, most of them falling about northwest. Mr. Landon's 1-story house, on a hill about 125 feet above sea-level on hard rock, was moved slightly to the west on its foundations. On this house 2 chimneys fell to the west. The earth was cracked on the low ground near the station, the fissures running north and south. The railroad clock stopt at 5<sup>h</sup> 13<sup>m</sup>.

*ML Tamalpais* (W. W. Thomas, of the Weather Bureau Observatory). — The observatory is in a slight depression between the east and middle peaks of the mountain. A number of rounded peaks form a prominent ridge about 3 miles in length, extending nearly east and west, and having an average elevation of about 2,500 feet. Rocks are exposed everywhere at the surface. No chimneys nor other tall structures were overthrown, but ornaments and small objects were thrown from shelves that ran north and south, or were more or less displaced in a direction somewhat south of west or north of east from their original positions. No objects fell from shelves that ran east and west, and no object moved north or south of its usual place was observed. An anemometer fell from the instrument stand to the floor, where it lay in a direction about west-southwest of its place on the stand. The instrument is so balanced that it takes no greater force to overturn it in one direction than in another. There were 2 maxima in the shock, and the first was the stronger. The direction of movement was about west-southwest and east-northeast. A vertical movement is inferred from the fact that all four of the direction arms on the triple register recorded at one time. This would indicate that the instrument received a sudden jar or series of jars in a vertical direction, for no electrical contact nor any amount of lateral shaking can cause all four of these arms to record at the same time. Some plaster fell, and a part of a loosely constructed stone wall was thrown down.

*Angel Island Light Station* (Mrs. J. E. Nichols). — The shock resembled the jolting of a railway train which, running at full speed, had left the tracks and was bumping over the ties. It was accompanied from the beginning by a loud noise which gradually decreased as the jolting motion ceased. Water standing in a pail was thrown out 6 feet from northeast to southwest. The clock was stopt. The bay was calm. A cement pavement was cracked to pieces. The station is on solid rock.

*Yerba Buena Island Naval Training Station* (Capt. A. T. Marix). — A heavy vibratory shock was felt.

*Alcatraz Island*. — A heavy shock was felt in which there were 3 maxima, the middle being the strongest. Objects were overturned in every direction.

*Southeast Farallon Island* (James A. Boyle, assistant observer of the U. S. Weather Bureau). — The ground is composed almost entirely of solid rock. The Weather Bureau building is on a narrow neck, 15 feet above sea-level, between 2 peaks about 300 feet high. Objects in this building were thrown east. A stone weighing about 100 pounds slid 6 inches west by south, and was turned slightly counterclockwise. There was no rotary nor vertical motion felt. There were 2 maxima, of which the first was the stronger, and the motion was east and west in both cases. The only damage done was the opening of a crack across the entire front of the fireplace. Two rock slides, of about 100 tons each, occurred on the west end of the island. At 10<sup>h</sup> 06<sup>m</sup> A. M., April 18, two distinct vibrations were felt. They were also felt by Mr. Legler, of the Weather Bureau Station at Point Reyes Light-house, with whom Mr. Boyle was talking over the telephone at the time, 3 seconds before they were felt on the island.

#### SONOMA VALLEY.

In the Sonoma Valley Mr. E. S. Larsen made the following observations:

*Melita*. — Chimneys are all down and plaster somewhat broken. Shock somewhat less than at Santa Rosa.

Between Melita and Kenwood conditions were about the same. Nearly all chimneys were thrown down or twisted.

*Kenwood*. — Most of the chimneys were down. The brick hotel was not much injured, but a few poorly constructed 1-story stone buildings were somewhat damaged.

*Glen Ellen*. — Chimneys were nearly all down. Popp's poorly constructed 2-story stone building was damaged so that the upper story had to be torn down. One wall of a brick building whose braces had been removed to make room for a stairway was much cracked. The other walls were little damaged. A clock with a half-second pendulum, facing south, stopt at 5<sup>h</sup> 13<sup>m</sup>. A fireman and an engineer on the San Francisco and Northwestern Railroad say that the shock started at exactly 5<sup>h</sup> 13<sup>m</sup>.

*Eldridge, State Home*. — All chimneys were thrown down and the upper story of each of the 3-story brick buildings was so damaged that it had to be removed. In a few cases there were cracks in the lower stories. One large electric clock with a second pendulum, facing northeast, stopt. Another clock with a half-second pendulum, facing southwest, did not stop, but its pendulum was turned about 20° clockwise.

*Aqua Caliente*. — Most of the chimneys were thrown down and the plaster was cracked. There was little damage to the brick and adobe houses.

*Boyes Hot Springs*. — An artesian well 97 feet deep now yields a larger stream.

*El Verano*. — Nearly all chimneys were down. A clock with a half-second pendulum and facing east stopt at 5<sup>h</sup> 15<sup>m</sup>.

*Sonoma*. Population 650. — Chimneys were nearly all down. Some of the brick and adobe buildings were damaged, but the shock was much less severe than at Santa Rosa. At the Hillside Cemetery, 0.125 mile east of the railroad depot, out of about 18 tombstones over 4 feet high and having the usual square or round section, 13 were

turned on their bases from a few degrees to 20° counterclockwise; 2 were down and 2 had the top ornaments thrown off. At the Catholic Cemetery, out of 6 tombstones of the above type 1 stone was turned clockwise and 1 counterclockwise. This cemetery is in the valley. The Valley Cemetery has 2 tombstones out of 6, of the above type, turned counterclockwise. The Sonoma Valley High School had 3 chimneys out of 6 turned counterclockwise; the other 3 fell. I found chimneys on 3 other houses turned counterclockwise, and 1 chimney turned clockwise. Two miles south of Sonoma, at Mrs. William Clemens', all 3 chimneys were turned counterclockwise. Mr. T. A. Lewis, physics teacher at the High School, described the shock as being at first a temblor, vibrating northeast and southwest, then a short calm, and finally a longer and harder twisting shake. Dr. Grey, of the State Home at Eldridge, and several others, gave a similar description.

*Shellville.* — About three-fourths of the chimneys were thrown, or twisted.

#### NAPA VALLEY TO THE SACRAMENTO VALLEY.

*Napa Valley* (C. E. Weaver). — At Calistoga, population 700, a large number of chimneys fell and 2 brick buildings were thrown down. Clock stopt. A few local slides on the south side of Mount St. Helena were confined to the alluvium. At the town of St. Helena, population 1,600, a stone building of the California Winery Association was slightly damaged, and 8 brick chimneys in the town were overthrown. At the Veterans' Home, at Yountville, the buildings constructed of brick and stone had two corners thrown down and the walls cracked. At Napa many brick buildings were cracked, and walls thrown down. Chimneys were generally overthrown. No damage was sustained by the concrete buildings, nor by the machinery contained in them, at the cement works at Napa Junction.

*Calistoga, Napa County* (Dan Patten). — Nothing was thrown down in the house. In the milk-house cream was thrown from full pans on the northeast side. A large water trough near the house had the water thrown out on the northeast side. Some large rock was thrown down from cliffs up on the mountain (Mount St. Helena) at an elevation of 4,000 feet on the northeast side. Mr. Patten was in front of the house, the east side, and heard a rushing noise. He had time to look up the road to the south, and then turn and look north, expecting to see some fast driving team, before the shock came. He felt first a tremor, and then 2 heavy thumps a few seconds apart; then tremors gradually decreasing until probably 0.75 minute had elapsed.

*St. Helena, Napa County* (F. Blachdowski). — At the Sanitarium near St. Helena, which is on a hillside with rock near the surface, objects were thrown mostly toward the east. Some chimneys were turned counterclockwise, and a twisting motion was felt. There were 2 maxima in the shock, the second being the stronger.

*Rutherford, Napa County.* — Mr. Joseph Mora was starting out on his bicycle when he heard a loud noise like that of a country wagon; he stopt and was then shaken by the earth moving violently; the trees swayed wildly. The sound and the shock came from the southwest. All the wine-cellars and structures that were not well built were partially thrown down. Chimneys came down from all buildings. Niebaum's wine building showed no cracks.

*The Veteran\*' Home* (A. Brown). — The Home is on sloping bench land in the foothills on the west side of Napa Valley. The chimneys on some of the buildings were twisted around, and some tumbled over. Mr. Brown felt his bed rocking north and south for about 15 seconds. A clock stopt. Some plaster fell at the new hospital. Only one maximum was observed in the shock.

Mr. J. M. Clark, of the Veterans' Home, who maintains a seismograph of his own construction at that institution, reports that the hardest portion of the shock came, as near as he could judge, about 20 seconds after the beginning. There was a rapid increase in intensity up to that time; then came the gyratory, upward, jerky motion, which was

very severe. This continued for about 10 seconds, and then came a swaying motion, that seemed at right angles to the first.

A chimney stack, of brick, 120 feet high, belonging to the power-house on the Home grounds, was shattered. Its rectangular faces fronted to the northeast, southeast, southwest, and northwest, respectively. In two places, one about 40 feet and the other about 60 feet from the ground, the upper portion of the stack was shifted, as if the rotation were from north to west to south to east, it being understood that the motion of the earth was in an inverse direction to that of the twisted distortion of the chimney. The westerly corner hardly moved while the easterly corner was shifted several inches. The lower fracture had a displacement of about 2 inches at the easterly corner, and the upper fracture had a similar displacement. In the dispensary of the Home, the first portion of the shock threw the bottles from the shelves upon northwest and southeast walls. The latter portion of the shock precipitated the bottles from the other walls. This was proven by finding articles from the northeast and southwest shelves lying on top of those from northwest and southeast shelves.

*Napa State Hospital.* — The effects of the earthquake are thus described in the Climatological Report of the U. S. Weather Bureau for April, 1906, by Mr. W. H. Martin:

At 5<sup>h</sup> 14<sup>m</sup> A. M. on the morning of April 18, 1906, a severe earthquake commenced, and lasted about 80 or 90 seconds. The apparent motion at the beginning was from the west by south to the east by north, a rolling motion for about 15 to 20 seconds, then a light interval for a few seconds, then a renewed force of a twisting nature, intensity IX. The ground, to the eye, seemed to be quivering; the hills seemed to have a rocking motion, the trees seemed to be shaken by the hands of a giant; everything looked to be in motion; the air was hazy and still. Many brick and stone walls were thrown to the ground and others damaged to such an extent that they will have to be taken down. Nearly all chimneys were thrown down, and of those standing some are turned a quarter way round. Milk in pans was thrown out in an easterly and westerly direction. The estimated damage to the city of Napa is about \$150,000. The damage to this institution was very light, except that the main tower will have to come down.

*Napa (E. C. Jones).* — The damage to street gas mains at Napa was very slight, only two leaks developing. The gas station was badly shaken up; about 10 feet of the end wall of the brick building was thrown down, falling on top of the boiler and breaking off the steam pipes. The gas-holders were badly shaken. Water was displaced from the tanks, but only one guide wheel was shaken out of place.

*Wooden Valley, Napa County (H. W. Chapman).* — On level alluvial ground near the base of the surrounding hills, no objects were overthrown. There were 2 maxima in the shock, of which the first was the strongest, the movement being north and south.

*Pope Valley, Napa County.* — The top of one very old chimney was thrown over, falling to the south. Another was cracked, and 4 or 5 bricks from the top of another fell down into the fireplace.

Mr. H. P. Gordon reports that he was in Pope Valley at the time of the earthquake, and that the shock awoke him. It seemed to be a tremor at first, then an oscillatory motion east and west. It seemed to him as if his bed were a gold pan, and he were being panned out. His house stands on rock.

*Berryessa Valley, Napa County.* — The shock is reported to have been quite heavy on the level land of the valley-bottom.

*Vattejo, Solano County.* Population 8,000. (W. D. Pennycook.) — The shock was quite as hard as that of 1898, when the brick structures at Mare Island navy-yard were very much damaged, some of them having to be taken down. The vibrations in that earthquake were lateral, nearly north and south. The vibrations of the earthquake of April 18, 1906, while equally severe, were different in character. In Mr. Pennycook's house are 2 mantels facing north and south, and a large china closet. In the earthquake of 1898 every article on both mantels was thrown to the floor, and in the china closet the crockery

was thrown from the shelves. On April 18, 1906, nothing was thrown from the mantels, but a clock, which in 1898 had been thrown to the floor, was turned around about 20°.

The postmaster of Vallejo reports that the city is on a hillside adjoining the Mare Island strait. The surface is rolling and has very little level land except such as has been cut down, which is entirely of clay and soft rock (shale). Sandstones and shales are the underlying rocks, and these come close to the surface except along parts of the edge of the strait. There was a noticeable decrease in the violence of the shock toward the middle, then an increase in severity, the latter part being the stronger. The movement was north and south. Objects hanging on gas fixtures by ribbons wound themselves up on the same. The Post-office clock stopt. The floors appeared to rise and fall. All the damage done was to chimneys; not a brick wall showed any injury. The greatest damage was done in the lower levels, the hills suffering very little.

(T. J. J. See.)—Vallejo is built on hard ground and did not suffer very severely from the earthquake. The best estimates obtainable showed that about one-tenth of the chimneys were knocked down, or so broken loose that they had to be taken down. The shock was not so severe as that of 1898, which was much more local in character. No house in Vallejo fell, and chimneys were about the only fixed objects thrown down. Various objects in the houses were overturned, such as bookcases, bric-à-brac, and dishes on shelves; and the plastering was somewhat cracked. In general, however, the injury was not great.

*Mare Island* (T. J. J. See). — The earthquake was much less severe than that of 1898, which wrecked many of the Government buildings in the navy-yard. None of the Government buildings was wrecked this time, nor was the damage at all serious except in the case of two or three new buildings recently erected on the "made" land near the water-front. Here the ground was thrown into violent undulations, and the buildings were so twisted that about \$2,000 worth of repairs had to be made. On this soft ground the brick walls were cracked, but as the buildings have steel girders, no part of them fell except one or two top-heavy cornices. But the swaying of the brick walls tied together with steel frames caused the walls to be cracked and scaled off near the steel supports. In the case of the older buildings resting on hard ground, no cracks were formed, nor any injury reported. No chimney on Mare Island was thrown down, and only one or two were broken loose at the roof so that they had to be taken down. The amplitude of the vibrations in the soft ground at Mare Island was found by measurement to be 2 or 3 inches. This was determined from the displacement of the loose dirt around the piles supporting the steel frames of the buildings on the "made" land. On the whole, the intensity was about the same at Mare Island and Vallejo.

Prof. T. J. J. See contributes the following note on the swaying of a smoke-stack at the navy-yard on Mare Island:

" This smoke-stack is made of steel, bolted together in sections and lined with fire-brick 150 feet high and 6 feet across at the top. Three separate witnesses, standing at nearly equal angles about the base, and something like 100 yards away, observed the tower writhing and twisting during the earthquake. The motion was described as like that of a corkscrew. All the witnesses say that the top of the stack vibrated in a circular or elliptical manner, thru a space of at least 2 diameters; that is, one diameter on either side from the mean position. The stack is built on hard ground, and bolted to a heavy brick foundation. The motion, therefore, gives the wave distortion of the solid earth, a motion of 6 feet at the top corresponding to a wave distortion of one-twenty-fifth part of the radius, or 2° 3'.<sup>1</sup> If the stack be regarded as vibrating about its center of gravity, the angle will be about half as large. These figures correspond to the distortion of the earth's level surface produced by the passage of the earthquake waves thru the rocky crust."

<sup>1</sup> This appears to involve the assumption that the stack was rigid, which is inconsistent with the described corkscrew motion. A. C. L.



Other observations mentioned by Professor See which are indicative of the intensity of the shock are the agitation of the water which was thrown into sharp cones, and filled with bubbles due to the escape of gases from the underlying mud; the shaking of trees and telegraph poles as by a storm; the fright noticed in all persons and animals; the throwing down of unstable objects; the raising of dust from the ground, and the formation of a mist in a few places. The motion was not so violent that one could not stand, yet during the violent part of the disturbance walking was difficult. All objects had a hazy outline, owing to the rapidity of motion, and it is said that persons presenting this aspect offered a comical sight to the beholder. The forests were agitated as by a violent wind, and at first the motion of the trees was ascribed by some marines on watch to a rising storm.

*Vallejo Junction* (T. J. J. See). — This station is just across the straits from the southeastern end of Mare Island and has only a few houses, the injury to which was not at all considerable. The intensity here was about the same as at Mare Island and Vallejo, as might have been expected from the proximity of these places.

*St. John's Quicksilver Mine*. — At the St. John's Consolidated Quicksilver mine near Vallejo, the following observations are recorded by Mr. Alphonso A. Tregidgo, manager of the mine. The note is of special interest as this is the only case in which underground disturbances have been observed in mines as a result of the earthquake of April 18:

We felt the shock about 5<sup>h</sup> 15<sup>m</sup> A. M., first north and south, and then east and west. We are working only two shifts, and as the night men "come off" at 4 A. M., there were no men in the mine when it occurred.

Our main tunnel is 1,135 feet in from the mouth. It cuts the lode 367 feet below the croppings, and crosses N. 3° 30' E. At the end of this tunnel the old shaft was sunk 230 feet deep (vertical). The first 130 feet was thru the lode, the remaining 100 feet being in the "foot" or west wall, the lode going down to the east of the shaft. Within the year preceding the earthquake a new shaft was sunk which this main tunnel intersects 500 feet nearer its mouth, 160 feet below the surface. Right at this point the effects of the earthquake appear in the tunnel. The posts of the sets were "snapt off" about 8 inches from the bottom, and forced north for several sets. Our tunnel is timbered thruout 8 x 8, sets 4 feet apart. The old shaft timber sets dropt on the east side from 2.5 to 3 feet. This shaft is double compartment. The wall plates are north and south, and end pieces east and west. Carrying the ends with them, the east wall plates dropt to the 180-foot level, so that all the sets above that level are now 2.5 feet low on the east side. (From a point 1,125 feet in the tunnel the center of this shaft is located 22 feet 5 inches E. 17° S.) We have repaired the tunnel, but the shaft is beyond repair. As we connected our new shaft with the old shaft workings below the main tunnel level on April 16, just two days before the earthquake, we fortunately have no need of the old shaft for working purposes, tho it will be necessary to keep it open a while for ventilation. Strange to say, our new shaft was not damaged at all. It is timbered from top to bottom nearly 400 feet; sets 4 feet apart, close lagged. Not a lagging even moved. From a point 610 feet from mouth of tunnel, the center of new shaft bears S. 76° 30' W. 14 feet 9 inches. No doubt considerable change has been caused by the earthquake in the old workings above the main tunnel, as our airways needed repairing in places.

*Benecia* (T. J. J. See). — The earthquake was decidedly more severe here than in Vallejo; 2 or 3 houses collapsed and half, or more than half, of the chimneys were thrown down. Major Bene't, U. S. A., Commandant of the U. S. Arsenal, informs me that he reported to the War Department over 20 chimneys on the Government houses in the military reservation either thrown down or so injured that they had to be taken down. These houses all stand on solid high ground, none of them being on land made by the filling in of loose earth. Some of the Government buildings were cracked and otherwise injured, but on the whole the damage was not very extensive. In Major Bene't's residence the furniture was considerably deranged, books were thrown down, bric-à-brac overturned and some of it broken. Such objects as dishes were frequently shaken off the shelves and crashed upon the floor.

At the entrance to the Arsenal grounds, the Gate House, used for the guard, is a round tower about 12 feet in diameter, made of brick and lined with a wooden ceiling. It was

built some 40 years ago, on a well-laid foundation going down to bedrock, which here underlies hard ground; yet the brick walls were badly cracked on every side. This guard-house stands on a high terrace, and the lower grounds appear to be alluvial deposits of the river.

In other parts of Benecia, brick houses built on hard ground were occasionally cracked. The town is somewhat spread out, some of it resting upon the alluvium near the river, the rest extending back over high rolling ground similar to that at the Arsenal. On the alluvial land the shaking was naturally most disastrous. A frame building near the water-tank, used for a saloon, collapsed; and a large cannery was so damaged that most of it had to be taken down. The water-pipe for the city was temporarily broken.

#### SACRAMENTO VALLEY.

*Red Bluff, Tehama County.* Population 2,750. (G. L. Allen.) — The earthquake awakened most sleepers. Quite a number of clocks were stopt. The chandeliers were caused to move considerably and in all directions. The tall head of a bed slammed against the wall, frightening the occupants. A lady tried to get up to keep an electric-light bulb, which was swinging violently, from striking a stove-pipe 2 feet distant from the cord; but she became dizzy and had to return to bed. The bulb did not strike the pipe. (J. H. Smith, Weather Bureau Observer.) No objects were overthrown, but hanging objects were caused to swing considerably. There was but one rather sharp jar, or shock, the direction of which is unknown. The inhabitants of the town were not unduly alarmed.

*Corning, Tehama County.* Population 1,000. (B. D. Wilkinson.) — I was awakened by what was at first thought to be wind moving the building; then I felt the bed and the building apparently roll in waves. Hanging electric lamps swung from south of east to north of west. Open doors swung for about half a minute.

*Chico.* Population 2,640. (W. M. Mackay.) — The shock here was quite pronounced, but not sufficiently so to do any damage. No chimneys were broken; nevertheless every house shook violently. I was awakened by the rattling of the weights in the windows. More than half the people interviewed say that the noise awakened them. Numerous clocks stopt, but no glassware or crockery was reported broken. In Chico Creek, adjoining the town, splashes on the bank indicated that there had been a violent commotion of the water. In places the water had been thrown several feet. The water-tank at the gas works was so disturbed as to cause the water to flow into the main, necessitating the pumping out of the main before service could be restored.

(E. Meyhew.) — I was in bed awake at the time of the shock. The motion was from north to south, and appeared to come in two waves, with an interval of about 6 seconds. The disturbance lasted about 15 seconds all together. It made windows rattle, and chandeliers and electric-light bulbs suspended by cords were caused to swing. It stopt 2 clocks in my store, one hanging on a southwest wall and the other on a southeast wall. All other clocks in the store continued going. A rumbling sound was heard thruout the disturbance.

*Willow\*.* Population 895. " (A. W. Sehorn.) — The motion increased until the weights in the window-frames rattled-considerably; trees swayed back and forth as in a hurricane for about 30 seconds, gradually diminishing. The movement appeared to be northeast to southwest, and was strongest near the middle. The clock was stopt, and the bed felt as if some one were pulling it. Chimneys were not injured. A rumbling noise preceded the shock.

Mr. G. K. Gilbert made a trip into the section of the Coast Ranges lying between the Clear Lake district and the Sacramento Valley. His purpose was to verify the report of a large rift said to have been made in St. John's Mountain by the earthquake. The rift was not found, tho sought for to the summit of the mountain; and the descriptions of it as an opening 10 feet wide by 20 feet long indicate that it is something quite different from

the ordinary manifestation of earthquake violence. The people at the base of the mountain were incredulous as to the existence of the crevice and especially as to its creation at the time of the earthquake.

As an outcome of this trip, Mr. Gilbert contributes the following note on the intensity of the earthquake shock at various points in the territory visited.

At *Williams* (population 500) the shock was strong enough to awaken people but not to throw down chimneys. It is said that small cracks were made in the walls of the hotel, a brick building. The intensity was about the same at Maxwell, population 300; Leesville; and Stony Ford, population 100. At Fouts Springs, 10 miles west of Stony Ford, only a few persons recognized the jar as due to an earthquake, and its identification was questioned by others until the news of the San Francisco disaster reached the place. As Stony Ford and Fouts Springs are near the east and south bases of St. John's Mountain, it is probable that the mountain was not severely shaken.

*Elk Creek, Glenn County.* Population 200. (P. E. Friday.)—The shock was very light. Some people heard windows rattle and noticed open doors swing slightly.

*Colusa.* Population 1,441. (Mrs. S. L. Drake.)—There was nothing overthrown, but water slopt from the tanks of the water-works on the north and south sides. The shock was so slight that only a few persons noticed anything more than a shaking, as tho some one had hold of the bedstead.

(E. S. Larsen.)—Many sleepers in Colusa were awakened, and some clocks were stopt, but there was no damage to chimneys and no glassware was broken. Window-frames in stores were in some instances displaced so as to leave a crack. Few cracks in plaster are reported. There is a general agreement that the vibrations were strong but slow and swinging. There is a fair agreement on the east and west direction for the vibrations. The jeweler had three pendulum clocks on the wall facing north. None of them stopt.

(Fred Roche.)—The shock in the central part of Colusa County lasted over a minute. There was only one continuous disturbance, but its intensity was strongest in the middle part. It caused windows to rattle, the bed to move, and hanging objects to swing, and overthrew some ornaments, but did not affect chimneys.

*Meridian, Suiter County.* Population 500. (T. F. Taylor.)—Two shocks were felt, the second being the stronger. No objects were overthrown.

*Marysville, Yuba County.* Population 3,497. (R. F. Watson.)—I was indoors, standing on the floor and stooping over when I felt quite a distinct tremulous motion for about 10 seconds before the main shock, causing a dizzy feeling. The shock itself started rather heavy and was jerky; it then became lighter until the second part of the shock came, with a rocking motion. The movement of the floor tipt me toward the southeast. No noise was heard. Windows and chairs rattled; electric-light bulbs suspended by cords first vibrated like a pendulum and then described a circle; and the pendulum clock stopt.

(A. B. Martin.)—The shock was sufficiently intense to arouse people from sleep, but no chimneys were broken nor was property injured.

*Yuba City, Sutler County.* Population 600.—The earthquake was generally felt; some sleepers were awakened and some clocks stopt. Movable objects were shaken. Water in horse-troughs was thrown several feet in an east and west direction in two cases, the troughs being oriented north-south and east-west respectively.

*Black's Station, Yolo County.* Population 300. (S. P. Cutter.)—No objects wore overthrown, but hanging objects were caused to swing in a circle. There were 2 maxima, of which the first was the stronger; and a vertical movement was felt.

*Knight's Landing, Yolo County.* Population 500: (L. T. Shamp.)—While no large objects were overturned, small ornaments were thrown in all directions, and the shock was violent enough to stop several clocks. There was more than one maximum, tho the first was the strongest. The water in the Sacramento River rose to a height of 3 to 4 feet in long sweeping swells.

*Lincoln.* Population 1,061.—Clocks were stopt.

*Fairoaks, Sacramento County.* Population 300. (L. M. Shelton.)—There was one straight shake, which was very light. People scarcely knew there was an earthquake.

*Sacramento.* Population 29,282. (J. A. Marshall.)—I was awakened by my wife's remark that she believed we were having an earthquake. Thus aroused, I lookt up and the chandeliers seemed to be oscillating several inches in an eastward and westward direction. This continued, together with the rattling of the window weights in their boxes, for about a minute, during which time we arose and observed and verified the phenomena. The oscillation slowly decreased, and ended in two considerable jars, with appreciable intervals between. The clock on the mantelpiece facing westward stopt. It is, I think, so constructed that it would not have stopt had the vibration been northward and southward. The shock here would grade V, Rossi-Forel scale; or, more properly, between V and VI; but there was no breakage. Another slight shock occurred soon after 8 A. M., April 18, and a more noticeable one at 3<sup>h</sup> 25<sup>m</sup> P. M., April 19, of about grade III; the motion in this case seemed to be north and south.

(E. C. Jones.)—The damage at the gas plant was very slight. The gas-holders rocked to such an extent that considerable water was thrown out of the tanks, and the seals of the holder sections were partially emptied, allowing gas to escape. No damage was done to the manufacturing apparatus nor to the street mains.

(Hiram Miles.)—I was looking at the clock when the shock commenced. It lasted 2 minutes and 17 seconds, the first half being oscillatory and the second half a tremor. The movement was decidedly northwest to southeast.

(Charles A. Hendel, C. E. and M. E.)—I was on the second floor of the Western Hotel. I jumped out of bed, opened the door, and placed a chair against it, so that it would not close on me while I was dressing. I had to hold on to the bed to get drest. The oscillation appeared to me to be like the shaking of a mouse or a rat, by a cat.

*Gait, Sacramento County.* Population 350. — The shock lasted 45 seconds.

*lone, Amador County.* Population 806. (J. F. Scott.)—The shock awakened and alarmed people. There were two distinct maxima, of which the second was the stronger. The direction of movement was north. No objects were overthrown.

(Win. Randall) The vibration was gentle but of such amplitude as to attract unusual attention. It was seemingly in a north and south direction, and estimated to continue for 20 or 30 seconds.

*Suisun, Solano County.* Population 625. (Mr. Sheldon.)—The shock awakened nearly every one, threw 2 or 3 chimneys, and damaged perhaps 25 per cent of the chimneys so that they required repairing. Masonic Hall had a few bricks thrown from an ornamental arched window. The plaster was much cracked, but there was no serious damage. Thruout both Suisun and Fairfield considerable plaster was cracked and even thrown down; a few bottles were thrown from shelves; a large proportion of the clocks were stopt; and a few windows were broken. There was no agreement as to direction. Vibrations were long and rolling.

*Elmira, Solano County.* Population 317. (E. S. Larsen.)—Most sleepers were awakened but no damage was done. There are few brick chimneys, and none of them was thrown or cracked. No plaster was thrown down and no windows were broken. As there are only a few small houses in the town it is rather difficult to make an accurate comparison; but the shock was probably considerably less severe than at Suisun, and slightly less than at Vacaville.

*Vacaville, Solano County.* Population 1,220. (E. S. Larsen.)—About 12 chimneys were cracked or thrown, some plaster was cracked, most clocks were stopt, and probably all sleepers were awakened. Things were very seldom thrown from shelves. There is a general impression that the vibrations were east and west, and that they were of a slow rocking nature.

*Esparto*. Population 200. — Clocks were stopt.

*Capay, Yolo County*. Population 200. (E. S. Larsen.) — Sleepers were awakened and milk slopt over in pans, but no chimneys were thrown, no windows were broken, and no clocks were reported stopt.

(S. Schwak.)—There was one continuous shake from northeast to southwest, resulting in the spilling of milk from pans. No objects were overthrown.

*Guinda, Yolo County* (J. Jacobsen).—There was one continuous shake for about 25 seconds, the apparent movement being from northwest to southeast. A vertical upward motion was also experienced. Nothing was overthrown.

*Rumsey, Yolo County* (J. M. Morrin). —The movement was from southeast to northwest. There were 2 maxima, the second being the stronger.

(E. S. Larsen.)—There was no damage whatever to buildings, but most sleepers were awakened. The vibrations were long and gentle.

*Woodland* (E. S. Larsen). —Most sleepers were awakened, but no chimneys were thrown and no glass was broken. A few clocks were stopt, one of which faced east. All agree that the vibrations were slow and gentle and of a rocking nature. Mr. J. L. Spohn states that he was awake at the time, and observed an electric-light globe hung by a cord. At first the globe vibrated east and west, and then had a rotary motion.

*Davisville* (E. S. Larsen). —Most sleepers were awakened. One man reports 2 or 3 chimneys cracked, but every one else denies this. Some plaster was cracked and doors were jammed so that they required resetting. No glass was broken. Various observers report vibrations from east to west or north to south, but they do not agree. All report the vibrations long and slow.

*Maine Prairie, Solano County* (Mrs. A. Rattike).—No damage resulted from the earthquake. A gentle swing was experienced, the motion of which was from southwest to northeast, as evidenced by waves generated on the surface of the water on the overflowed land.

*Rio Vista, Solano County*. Population 682. (J. C. Stanton, C.E.) —The character and effects of the shock are described in a note published in the Climatological Report of the U. S. Weather Bureau for April, 1907, as follows:

The shake was very severe. It commenced with a number of quite long vibrations from northwest to southeast and wound up with the figure 8 motion which often accompanies seismic disturbances. It was quite difficult for persons to maintain their footing; but strange to say, nothing was thrown down or overturned, which may be attributed to the gyrating motion. The duration was about 30 seconds, and I am convinced that had it continued 30 seconds longer hardly a house would have been left standing in town. Some lumber piles were thrown down in a lumber yard situated upon a pile wharf, where the disturbance seemed worse than anywhere else; and the water-tower, 60 feet in height, consisting of 2 large tanks containing 100,000 gallons, was seen to sway violently.

*Collinsville, Solano County*. Population 300. (Joseph Antonini.)—Collinsville is on the peat of the tule land, with hard clay 2 feet below the surface. The largest building in town, a hotel built on piles, was totally wrecked. Chimneys and water-tanks were overthrown. The movement was east.

#### NORTHERN SIERRA NEVADA.

*Butte County*. — At John Adams, population 75, and at Berdan, a slight trembling of the earth is reported. At Paradise, population 100, Mr. F. W. Day reports that hanging objects vibrated violently, and that a "sinking sensation" was experienced. At Stanwood the shock, according to Mr. S. E. Rowe, was very slight and noticed by very few people. At Honcut, population 100, a slight shock is reported by Mr. D. B. Robb.

*Quincy, Plumas County*. Population 516. (L. A. Barrett.) — The shock was heavy enough to awaken a few people, but was not felt by the majority of the inhabitants. Mr.

J. W. Street, watchmaker, reports that his clock stopt in consequence of the shock. This was the only clock in town that stopt.

Other points in Plumas County at which the earthquake is reported to have been felt as a slight shock are Greenville, population 640; Taylorsville, population 130; Kettle; and Beckwith, population 100. At La Porte (population 300), Mr. Oscar Freeman says: "The shock was very light. There were but few persons in town that felt it, perhaps a dozen. It made the house creak as would a sudden gust of wind, set the hanging lamp swinging, and seemed to have a twisting or circular motion, as near as I could judge."

*Sierra County.* — Slight shocks are reported to have been felt at Table Rock, by John K. Walls; and at Allegheny (population 200), by W. A. Clayton. At Loyalton (population 100), Mr. J. J. Miller reports a confused shock in three parts. An electric bulb hanging from the ceiling was caused to swing in a circle. At the west side of Sierra Valley, in the tule land, the quake was more severe, and caused dishes to rattle and loose objects to sway.

*Nevada County.* — A slight shock is reported at the following points: Fernley, by G. V. Robinson; French Corral (population 150), by W. E. Moulton; Grass Valley (population 4,719), by C. W. Kitts; Chicago Park, by E. F. Sailor; North Columbia, by Mrs. C. J. English; Washington (population 500), by J. H. English; and Floriston, by W. I. Sunburnt. At Boca (population 50), Mrs. A. E. Daswell reports that the shock comprized only one movement, which lasted about one minute and was strong enough to make an electric-light bulb swing. At Truckee (population 1,600), W. S. T. Smith reports that the shock was felt by a number of people. Windows rattled, hanging objects swung, and a clock stopt. No objects were overthrown.

*Placer County.*—According to the reports received, the shock seems to have been less generally felt than to the north or south. A slight shock, noticed by few people, is reported to have been felt at Newcastle, population 600; Auburn, population 2,050; Yankee Jim, population 150; and Emigrant Gap, population 60.

*Georgetown, Eldorado County.* Population 400. (C. M. Fitzgerald.) — The shock was distinctly felt by most people, and the disturbance was sufficient to awaken those not already up. No objects were, however, overthrown. The movement was decidedly from north to south. The duration was estimated at 30 seconds.

*Nashville, Eldorado County.* Population 50. (J. C. Heald.) — But few people felt the quake. Many spoke of some disturbance having awakened them. The few who were awake at the time felt the jar, but did not know what it was. The shock was felt somewhat more distinctly to the north and south of Nashville.

*Pino Grande, Eldorado County* (W. E. Borham.) — Few felt the shock, which was light. Hanging objects swayed back and forth. No objects were overthrown.

*Drytown.* Population 300. (Allen Me Wayne.) — The shock was felt by only one or two people in town.

*Milton, Calaveras County.* Population 200. (J. H. Southwerk.) — The shock was distinct. There were 2 maxima, and the second was probably the stronger. The direction of movement was east and west. Mr. S. D. Hildebrand, who was on the bottom-land of the Calaveras River, 3 miles west, felt a more violent shock, but no damage was done.

*Railroad Flat, Calaveras County.* Population 200. (R. B. Knox.) — Mr. Knox was awakened by a smart shock which shook his bed for nearly a minute.

*West Point.* Population 266. (Mr. Balsley.) — A pail of water two-thirds full slopt over; pans rattled, and the clock was moved on the wall. The shock moved Mr. Balsley's bed from side to side, southwest to northeast.

A shock was reported, without further details as to its effects, at Campo Seco; Esmerelda; Mokelumne Hill, population 575; Nassau, population 50; North Branch; and Vallicita, population 500.

*Gold King Mine* (Henry Seeman). —Near Gold King Mine, sec. 26, township 6 N., Range 14 E., a moderate shock was felt. This was, however, not noticed by any of the 15 persons at the mine, less than 0.25 mile away, nor by the night shift in the mine, and awakened no sleepers.

*Blanchard, Tuolumne County* (Mrs. C. E. Blanchard). — One chimney was damaged slightly, but the shock otherwise did no damage. The shock was light, tho generally felt in the surrounding country.

*Columbia, Tuolumne County*. Population 500. (J. W. Pitts.) — The shock was so light that those asleep did not feel it and did not wake up. Mr. Pitts and others who were up felt a slight shock and motion from north to south.

*Sonora, Tuolumne County*. Population 1,922. (J. E. Coover.)—The movement seemed to be an easy rocking one, free from jerks, with considerable amplitude. The earthquake was in full swing when Mr. Coover awoke; it held its maximum intensity for some moments, it seemed a half-minute, and then diminished gradually. A pendulum clock stopt.

*Tuolumne, Tuolumne County* (Capt. J. T. Thompson). — In the Turnback Inn, a large frame structure, some window glass was crashed diagonally, and sleepers were generally awakened. The movement was oscillatory and seemed to be east and west. At the Grizzly Mine, in the bottom of Tuolumne Canyon, about 1,000 feet below the town of Tuolumne, the shock was not felt.

*Jupiter, Tuolumne County* (Cornelius Quinlan). — Was awakened by the shock at 5<sup>h</sup> 14<sup>m</sup> A. M., and experienced a sliding back and forth from north to south for about 20 seconds after awakening.

*Sequoia, Tuolumne County* (Mr. Crocker). — Two prolonged light shocks were felt, of the nature of a pronounced tremble. Some members of Mr. Crocker's family did not feel it.

*Yosemite Valley*. — A slight shock was felt.

**DISTRIBUTION OF APPARENT INTENSITY IN SAN FRANCISCO.**

BY H. O. WOOD.

## INTRODUCTION.

In presenting the results of this study, the subject-matter has been taken up as follows: First, brief mention is made of the physiographic features of the city. Map No. 4, of the atlas accompanying the report of the Commission, shows the location of the city and its physiographic environment, also a segment of the Rift and of the fault on which the earthquake of 1906 was generated, and the position of a similar fault where the shock of 1868 originated. The city lies between these two zones of faulting. Then follows a note on the general geology of the region, illustrated by a geological map, No. 17 of atlas, prepared by Professor Andrew C. Lawson, on which is shown the areal distribution of the more important rock formations and of the districts of "made" land. Then comes the description and classification of typical destructive effects examined in the field. An intensity scale is discust, and its relationships to the Rossi-Forel and Omori scales are determined as well as possible. By critical comparison with Omori's scale, approximate values are fixed for the grades in terms of acceleration. Illustrating this discussion, map No. 19 of the atlas, showing the areal distribution of intensity in terms of an especially devised scale, presents graphically the results of the investigations in the city. The methods employed in the preparation of the map are set forth; also the manner in which the intensity scale was utilized. In map No. 18 are shown several geological cross-sections with corresponding intensity profiles. As vertical coördinates of the latter, values of the grades determined approximately in terms of acceleration were utilized.

Following the general discussion of the intensity is a detailed description of the evidence which characterized various localities and determined the intensity grades ascribed to them.

Next are discust details of evidence in the localities where very high intensity prevailed, which are of general interest owing to the suggestions they offer, the problems they raise, or the warnings they proclaim.

## PHYSIOGRAPHY.

The San Francisco peninsula rises with bold relief from the level of the sea to hill summits varying in altitude between 100 and 1,800 feet, with the broad Pacific to the west of it, the waters of San Francisco Bay to the east, and the Golden Gate on the north. Southward, trending slightly east, the peninsula runs for several miles, merging finally with the hills of the Santa Cruz Range which mark the eastern limits of the Santa Clara Valley. On the western shore, promontories such as Point Lobos, Mussel Rock, San Pedro Point, and Montara Point, where rock-cliffs rise out of the surf, alternate with stretches of smooth beach line. At the north, the hills come down to the shore, forming rocky points: Point Lobos, where the Cliff House stands; Fort Point, marking the narrowest part of the Golden Gate; and the minor promontories of Black Point and Telegraph Hill farther east. The eastern shore is marked by prominent rock ridges extending out into the Bay, while between these, reaching well back into the hills, are sharply limited valleys cut down to the level of the sea and filled with deep deposits of alluvium, thus forming a gontly sloping floor from which the hills rise abruptly. Before the building of the city, tide marshes with their little tidal creeks occupied the floors of these valleys, near their mouths.



The most important of these is the relatively large Mission Valley, opening into the Bay between Rincon Point and Potrero Point and extending back westward and then southward, with a minor fork to the northwest) fully a quarter of the way across the peninsula. Mission Creek, with its lagoon and contiguous marsh, before it was filled to provide street and building sites, extended from the Bay shore around the northern extremity of the hills of the Potrero. Another long narrow marsh occupied a part of the floor of Mission Valley, stretching eastward from the present site of the Post-office building for several blocks, and then turning southward to the old Bay shore. This marsh also has been filled to provide building sites. Another dominant valley is that of Islais Creek, stretching back to the southwest between the hills of the Potrero and those of Hunters Point. This valley is outside the city proper.

The city and county of San Francisco occupy the northern end of the peninsula, bounded on the south by an arbitrary east-west line some 7 miles south of the Golden Gate. The city, properly speaking, occupies the northeastern third of this area, covering the summits and flanks of the sandstone hills known as Telegraph Hill, Nob Hill, and Russian Hill, on the north; and other unnamed summits on the west. It covers also the floor of Mission Valley and reaches well up on the flanks of the hills which culminate in the center of the area. On the outskirts of the city proper, except in the southwestern part, are small detached groups of dwellings in the hills or on the sands.

Market Street is a broad thoroughfare running southwestward from the Ferry Building and the wharves, at the northeast corner of the city, thru Mission Valley to the flanks of the high hills in the center of the area. About the lower part of Market Street is the commercial center of the city. The City Hall, situated about 1 block north of this broad highway, and about 12 blocks southwest of the Ferry, was not far from the center of the city proper.

The zone of faulting where the recent earthquake had its origin past under the sea from a point near the head of Bolinas Lagoon, 12 or 15 miles northwest of the Golden Gate, to a point half a mile north of the little headland of Mussel Rock, about 8 miles south of Point Lobos. The map, No 4, shows its location.

The entire area of the city and county is east of the fault-zone. The southwest corner of the area is less than a mile distant from it. The vicinity of the Ferry Building, at the foot of Market Street, was the most remote of any point in the whole area, being between 9.25 and 9.75 miles away. The site of the City Hall is from 7.5 to 8 miles from the fault. The Cliff House, at Point Lobos, the most western point of the area, is about 3 miles east of it. Fort Point lies between 5.75 and 6 miles east of it. Potrero Point and Hunters Point, as well, are about 8.5 miles from the fault. Hunters Point is the most easterly point in the district.

#### GEOLOGY.

It is desirable to insert here a brief abstract of the geology of the northern part of the San Francisco peninsula, for it will appear that the effects produced by the earthquake were largely influenced by the character of the underlying formations. Map No. 17 shows the distribution of the geological formations at the surface. It shows also the areas of "made" land. These areas were determined by plotting the shore line shown on the accurate chart published in 1853 by the U. S. Coast and Geodetic Survey, upon the latest accurate chart of the same bureau. In these districts the materials forming the surface have been transported to their present position by human agency. The depth or thickness of this "filled" stratum is variable and, for the most part, not definitely known.

A little study, comparing the areas of rock with the topographic contours, shows that all the hills are of firm rock, mostly coated with a veneer of soil and vegetation, but frequently outcropping at the surface. In general, their lower flanks are more and more thickly covered with loose sand and alluvium the nearer approach is made to the floor of

the valleys or the districts of sand-dunes. At the lower levels such loose materials cover the whole area very generally. The thickness of these strata must be notably variable, considering the uneven configuration of the rock surface where it emerges from this mantle, since it is probably no less irregular beneath the covering. Very little information is available concerning the depths to which these uncemented materials extend. A well at the United States mint is about 176 feet deep and is believed not to have reached bedrock. A boring that was sunk at the corner of 7th and Mission Streets past thru sand and clay to a depth of 264 feet, but did not reach bedrock. In general the sands and clays fill deeply the major valleys, Mission and Islais. The minor northwest fork of Mission Valley, called Hayes Valley along its lower part, is probably less deeply filled. This is certainly true of its upper reaches, to which, in this report, the name Upper Hayes Valley is applied. Minor valleys and gullies all over the area have thin coverings of sand and alluvium which quickly thin out where the slopes of the hills begin to rise steeply.

From the ocean inland for a considerable distance extends an area covered with sand-dunes. This district is limited irregularly at the east by the contour of the hills. The sands form a thick mantle near the ocean shore, which becomes thinner and thinner as it rises upon the lower flanks of the hills. As in the case of the materials filling the valleys, the rock floor upon which the sands rest is probably very irregular.

Of the hills, the northern ridge is carved out of the firm sandstone of the Franciscan series. Along this ridge are the summits of Telegraph Hill, Nob Hill, and Russian Hill, with other unnamed hilltops to the west, separated from each other by little saddle-like depressions in the surface. The outlying summits of Black Point and Rincon Hill appear to belong genetically to this ridge. This body of sandstone abuts on the west against a mass of serpentine, which forms a narrow range of hills stretching southeastward across the peninsula from Fort Point to Potrero and Hunters Points.

This serpentine is intrusive in the firm Franciscan rocks, chert, and sandstone. The southwestern boundary of the serpentine in the vicinity of Fort Point is determined by a fault which has a throw of about 1,000 feet. This fault may possibly extend quite across the peninsula along the southwestern limits of the serpentine, but the field evidence does not warrant any definite statement. The fault movement occurred so long ago that the present land surface gives no unequivocal indication of its position. Mission Valley cuts across the body of serpentine, separating the northern hills from the southern group. The northern group rises along the western boundary of Hayes Valley.

The central and southern hills, and the ridge at the northwest of the city, are carved intricately from firm Franciscan rocks, sandstone, and chert, commingled with minor bodies of irruptive rock of basaltic character.

The hills of the more remote southwest corner of the city and county are of softer rocks of more recent geological origin — sandstones and shales of the Merced formation. These are relatively little cemented. Readers interested in a more complete account of the geology should consult the detailed report on this peninsula.<sup>1</sup>

#### DESTRUCTIVE EFFECTS AND INTENSITY SCALES.

To some extent the earthquake caused damage to buildings and other structures in all parts of the city and county of San Francisco. The whole area was decidedly within the destructive zone. Still, over a large part of this area, far the larger part, the damage was slight both in amount and character. Almost everywhere chimneys were thrown down or badly broken, but in a few small localities most of the chimneys withstood the shock. Some probably were unhurt. Plaster on walls and ceilings was very generally damaged. So, probably, were frail partition walls and chandeliers, crockery and fragile household furnishings. Such effects were typical of large sections of the city. There

<sup>1</sup> The Geology of the San Francisco Peninsula, by Andrew C. Lawson, 15th Ann. Rept., U. S. G. S.

were relatively small districts, however, in which brick and frame buildings of ordinary construction were badly wrecked or quite destroyed. Pavements were fissured, buckled, and arched. Sewers and water-mains were broken. In places, portions of streets were moved laterally several feet out of place. Well-ballasted street-car tracks, equipped with 8, 10, or 11 inch rails, were arched and flexed or thrown into shallow wave forms. The whole land surface, sometimes for several blocks together, was deformed into shallow waves of irregular extension, length, and amplitude. Effects of this degree of violence were pretty closely confined, as has been stated already, to areas of "filled" or "made" land. Such characterize, therefore, only a small portion of the city; but, as it happens, areas of commercial importance and of special interest for the scientific purposes of this inquiry. In consequence they will require a relatively large share of attention.

These destructive effects vary in degree from place to place thru the whole range between the extremes cited. In some cases this variation is best shown by the character of these effects; again by the frequency of their occurrence. The change from strong effects to weak sometimes takes place rather abruptly within the distance of a block or two, or less. Commonly the localities where very violent effects were produced are themselves pretty sharply limited. In such cases, however, there is still a noticeable variation in the sort and amount of damage resulting at different points just outside their limits, along their peripheries. At other places the destructive effects change gradually thru a distance of several blocks.

This areal variation in the degree of damage indicates clearly a like variation in the intensity of the shock. The effects produced are the direct results of the intensity manifested, since where nearly all kinds of structures are to be found in all districts, of whatever intensity, such factors as the individual strength of the injured structures must practically cancel in the aggregate result. Consequently the destructive effects furnish a measure of the intensity, not very precise, it is true, but the best available, since no seismographic instruments were maintained in the city. By a classification of these effects different grades of intensity can be recognized and defined.

Several such classifications have been made by seismologists for this purpose. The best known of these is the Rossi-Forel intensity scale, which provides ten scale numbers. The first defines a shock just barely perceptible to a sensitive observer, or one recorded by a sensitive seismograph; the tenth, a great disaster. The four highest numbers of this scale, as republished by the present Commission in its Preliminary Report, are as follows:

VII. Violent shock, overturning of loose objects; falling of plaster; striking of church bells; some chimneys fall.

VIII. Fall of chimneys; cracks in the walls of buildings.

IX. Partial or total destruction of some buildings.

X. Great disasters; overturning of rocks; fissures in the surface of the earth; mountain slides.

The range of intensity in the city did not exceed these limits. Probably it did not reach the higher numbers recognized by the scale number X. In only a few small localities were the minimum values of scale number VII prevalent. It is easy to see, however, that this scale distinguishes its three upper scale numbers in vague terms, particularly with regard to effects likely to be produced in a modern city. For this reason it was found unsatisfactory for the investigations in San Francisco.

A scale of greater merit is that devised by Professor Omori, of Tokyo, given below:

No. 1. Maximum acceleration is 300 mm. per sec. per sec. People run out of houses; brick walls of bad construction are slightly cracked; plaster of some old dozo (godowns) shaken down; wooden houses so much shaken that cracking noises are produced; trees visibly shaken; water in ponds rendered slightly turbid in consequence of the disturbance in the mud.

No. 2. Maximum acceleration is 900 mm. per sec. per sec. Walls in Japanese houses cracked; old wooden houses thrown slightly out of the vertical; tombstones and stone lanterns of bad construction overturned; in a few cases changes are produced in hot springs and mineral waters; ordinary factory chimneys not damaged.

No. 3. Maximum acceleration is 1,200 mm. per sec. per sec. About one factory chimney in every four is damaged; brick houses of bad construction are partially or totally destroyed; a few old wooden dwellings and warehouses totally destroyed; wooden bridges slightly damaged; some tombstones and stone lanterns overturned; shoji (Japanese paper-covered sliding doors) broken; roof tiles of wooden houses disturbed; some rock fragments thrown down from mountain sides.

No. 4. Maximum acceleration is 2,000 mm. per sec. per sec. All factory chimneys are broken; most of the ordinary brick buildings partially or totally destroyed; some wooden houses totally destroyed; wooden sliding doors and shoji mostly thrown out of their grooves; cracks 2 or 3 inches in width, in soft or low ground; embankments slightly damaged here and there; wooden bridges partially destroyed; and ordinary stone lanterns overthrown.

No. 5. Maximum acceleration is 2,500 mm. per sec. per sec. All ordinary brick houses very severely damaged; about 3 per cent of the wooden houses totally destroyed; a few *tera*, or Buddhist temples, are thrown down; embankments severely damaged; railway lines slightly curved or contorted; ordinary tombstones overturned; *ishigaki*, or masonry walls, damaged here and there; cracks 1 to 2 feet in width produced along river banks; water in rivers and ditches thrown over the banks; wells mostly affected with changes in their waters; landslips produced.

No. 6. Maximum acceleration is 4,000 mm. per sec. per sec. Most of the *tera*, or Buddhist temples, are thrown down; 50 to 80 per cent of the wooden houses totally destroyed; embankments shattered almost to pieces; roads made thru paddy fields so much cracked and depressed as to stop the passage of wagons and horses; railway lines very much contorted; wooden bridges partially or totally destroyed; tombstones of stable construction overturned; cracks a few feet in width formed in the ground, accompanied sometimes by the ejection of water or sand; earthenware buried in the ground mostly broken; low grounds, such as paddy fields, very greatly convulsed both horizontally and vertically, sometimes causing trees and vegetables to die; numerous landslips produced.

No. 7. Maximum acceleration is much above 4,000 mm. per sec. per sec. All buildings except a very few wooden houses are totally destroyed; some houses, gates, etc., projected 1 to 3 feet; remarkable landslips produced, accompanied by faults and shears of the ground.

In the foregoing scale, in addition to these definitions by destructive effects, it will be noticed that a range of values for the *acceleration* is assigned to each scale number. These acceleration values have been tested experimentally by Professor Omori, and found accurate within narrow limits. Consequently it is called an *absolute* scale. It is the best intensity scale yet proposed. Since, however, it is defined in terms of damage produced upon Japanese structures, it would require constant critical interpretation in use in an American city. For this reason, it is believed to be not so well adapted to the purposes of this investigation as the scale proposed below. This is especially true since the values of the acceleration necessary to produce the destructive effects encountered here have not been determined by experiment. A use of the absolute scale would, therefore, pretend to an accuracy not attained with any certainty. The following scale will be referred to as the San Francisco scale:

*Grade A. Very riotful* — Comprizes the rending and shearing of rock masses, earth, turf, and all structures along the line of faulting; the fall of rock from mountain sides; numerous landslips of great magnitude; consistent, deep, and extended fissuring in natural earth; some structures totally destroyed.

*Grade B. Violent.* — Comprizes fairly general collapse of brick and frame buildings when not unusually strong; serious cracking of brick work and masonry in excellent structures; the formation of fissures, step faults, sharp compression anticlines, and broad, wave-like folds in paved and asphalt-coated streets, accompanied by the ragged fissuring of asphalt; the destruction of foundation walls and underpinning structures by the undulation of the ground; the breaking of sewers and water-mains; the lateral displacement of streets; and the compression, distension, and lateral waving or displacement of well-ballasted street-car tracks.

*Grade C. Very strong.* — Comprizes brick work and masonry badly cracked, with occasional collapse; some brick and masonry gables thrown down; frame buildings lurching or listed on fair or weak underpinning structures, with occasional falling from underpinning or collapse; general destruction of chimneys and of masonry, brick or cement veneers; considerable cracking or crushing of foundation walls.

*Grade D. Strong.* — Comprizes general but not universal fall of chimneys; cracks in masonry and brick work; cracks in foundation walls, retaining walls, and curbing; a few isolated cases of lurching or listing of frame buildings built upon weak underpinning structures.

*Grade E. Weak.* — Comprizes occasional fall of chimneys and damage to plaster, partitions, plumbing, and the like.

This scale obviously is simply a classification of the phenomena observed. It defines as many grades as the facts seemed to express in this field. It is more finely subdivided than the Rossi-Forel scale and, for conditions in a modern city, the definitions are better framed. It has less intrinsic merit than the Omori scale, for both scales cover a similar range of destructive effects, but the subdivision is finer and more evenly spaced in the case of the Omori scale. Also the grades of the San Francisco scale can not be fixed by values of the acceleration, except approximately by comparison with the absolute scale. The fact, however, that it does not pretend to absolute values seems a point in its favor under the circumstances. And it is a practical scale for the phenomena dealt with.

Altho rigorous values can not be obtained by such means, it is desirable to subject the grades to careful comparison with the numbers of the Omori scale in order to determine reasonably close acceleration values for them.

A comparative study of the 3 scales is summarized diagrammatically in the accompanying table at the top of next page.<sup>1</sup>

Some of the effects which serve to define Grade A are weaker than the maximum effects defining No. 6 of the absolute scale; and nowhere, not even in the vicinity of the fault, were most buildings totally destroyed.

Grade B covers a wide range. Perhaps if the initial shock had been a little stronger; it could have been subdivided with some certainty.

Grades C and D cover each a slightly lower range of values than the scale numbers 3 and 2, to which they correspond most closely.

Grade E, as defined, is more narrowly limited than No. 1.

These values, despite their lack of precision, constitute the best approximation to an absolute measure of energy developed, for each grade of intensity, which it appears practicable to attain. There were no instruments of precision to record the character and amount of the motion of the shock, hence estimates of other sort than this seem difficult to make. The fact must not be lost sight of, however, that it is only an estimate, based upon the interpretation of a series of destructive effects produced in very variable media under variable conditions and then compared with a similar series of destructive effects produced in structures of a different sort, for which pretty accurate acceleration values had been determined experimentally.

<sup>1</sup>The definitions of the Omori absolute scale and the information about it are taken from the book on Earthquakes in the Light of the New Seismology, by Major O. E. Dutton.

E.OSSI-FOREL SCALE.	OMORI SCALE.	SAN FRANCISCO SCALE.	ACCELERATION <i>mm.</i> PER SEC. PER SEC.
10	No. 7	Grade A	4,000
	No. 6		3,000
	No. 5	Grade B	2,500
	No. 4		2,000
9	No. 3	Grade C	1,200
8	No. 2		Grade D
	No. 1	Grade E	

It may be perhaps well to point out that Grade D lies between Nos. VII and VIII of the Rossi-Forel scale. This grade characterizes the greater part of the city, as the intensity map shows. Grade B, equivalent to Nos. IX and X of the same scale, is characteristic of very small areas only. Grade A is not exhibited in the city proper.

Utilizing the San Francisco scale, intensity map No. 19 was prepared, which indicates the location and areal extent of the districts characterized by each grade of intensity. It presents graphically the results of the field work. In the field study, practically all of the city proper, including the large area devastated by fire, was thoroly traversed, excepting one or two isolated hilly localities where a brief examination showed no significant damage. Unbuilt districts were, of course, comparatively neglected, except where disturbances of natural objects were found or lookt for. Chimneys, buildings, streets, paving, curbing, sidewalks, car tracks, retaining walls, etc., were subjected to careful scrutiny, and such injuries as were observed were classified on the spot in terms of the San Francisco scale. The intensity indicated was recorded by a spot of color placed upon a field map of suitable scale (1,760 feet to the inch, or 1: 21,120). Many photographs were made, some of which appear as illustrations in this report.

Detailed field notes were made only when damage of unusual or striking character was encountered, or when it was perplexing. When effects were observed which seemed likely to be of value in analyzing the character of the earth motion, notes were made. Little indoor evidence was obtained or sought.

It will thus be seen that the field study, while adequate for the purposes in view, did rnot constitute an expert engineering investigation, dealing with specific details and location of damage. Frequently there was doubt as to what grade of intensity should be assigned to a given city block, because of conflicting or inadequate evidence in the field. This is particularly true of districts swept by fire, especially where the intensity was low; for most

of the effects which serve to define the lower grades were obliterated with, the structures in which they were developed. Where buildings were sparsely distributed, it was often hard to determine what grade of intensity was developed, for the evidence was scattering and heterogeneous. Nevertheless, the map is a pretty faithful representation of the distribution of intensity, and quite justifies the scientific and economic conclusions of a general nature that are drawn from it here.

On the map, color in northwest-southeast bars (A, B, C, D, E) represents districts marked by unequivocal evidence. Continuous lines indicate the position of well-determined boundaries between areas affected by different grades of intensity. Color applied in northeast-southwest bars (a, b, c, d, e) represents districts in which the evidence was scanty or circumstantial; and dotted lines indicate the position of boundary lines which were determined but vaguely by the phenomena in the field.

#### DETAILED DESCRIPTION OF THE EVIDENCE BY LOCALITIES.<sup>1</sup>

No district designated upon the map as exhibiting intensity of Grade E, so far as the writer could find, exhibited any destructive effects of a more violent kind than the fall of chimneys. The really typical measure of intensity for these localities was the cracking and falling of plaster. Without exception, these are places where the firmly cemented bedrock of the Franciscan formations is either exposed directly or covered with a very thin mantle of soil. This lowest grade of intensity does not, by any means, characterize all places where the firm bedrock is exposed at the surface. It was rather developed on the summit portions of the rocky hills. The tops of Telegraph Hill and Russian Hill are districts in which a large part of the chimneys withstood the shock. This was also the case with the upper slopes of the chert hills about the head of Market Street, at the center of the area. Scarcely any injuries resulted on the hills of the Potrero; and one or two small serpentine hills just north of Market Street were likewise immune. Similarly, the Hunters Point serpentine ridge was subjected to a shock of low intensity; at least, a hasty survey pointed to this conclusion, tho the evidence was sparse and not thoroly examined. San Bruno Mountain, however, was about as near to the zone of faulting as Point Lobos, where most of the chimneys were thrown. Intensity of Grade D is believed, therefore, to have been developed upon the summit of San Bruno Mountain.

The general fall of chimneys, slight cracking of brick work, and such damage, denoting intensity of Grade D, characterizes the northeastern half, or possibly two-thirds, of the city and county, except in localities where special conditions, chiefly lithological, modify it. Districts of exposed bedrock on the flanks of the hills, and of sand and alluvium wrapped as a thin mantle about their lower slopes, exhibited this degree of damage. Consequently a large area was affected by this grade of intensity which does not, in general, require detailed discussion; no violent nor specially significant effects being produced. Where, however, the loose earth covering is thicker, the magnitude and frequency of damage increases. Market Street, between Second and Fourth Streets; Mission Street, between First and Third Streets; and Howard Street, between Second and Third Streets, together with the blocks in the neighborhood of Market Street on Montgomery and Kearney Streets, Grant Avenue, Stockton and Powell Streets, form a district in which the effects denote an intensity only a little short of Grade C. A large proportion of the buildings were excellent structures which individually withstood the shock well. In consequence, it was difficult to draw a line in this region between districts marked by broken chimneys and cracked brick walls, and those where more serious damage was certainly developed. The resistant character of the excellent buildings and the thoro obliteration by the fire of evidence produced in poor structures, render the determination of the intensity as Grade D somewhat doubtful.

---

<sup>1</sup> The streets referred to in these descriptions are shown on map 20 of the atlas.

In the blocks adjacent to Point Lobos Avenue and Clement Street, between First Avenue and Sixteenth Avenue, in the sand-dune district, damage — mostly of Grade D — was prevalent. This locality is the part of the city nearest to the seat of the disturbance, and the cover of sand which rests upon the uneven bedrock is unevenly thick; therefore irregular variations of intensity are to be expected. Nevertheless it is not easy to fix the boundaries between Grade C and Grade D in this part of the city.

Along Oak and Fell Streets, and the Panhandle Parkway from Broderick Street west, the intensity closely approaches Grade C without seeming quite to reach it.

Along Washington Street and its immediate vicinity, from Baker Street west to Spruce Street, on the crest of the sandstone ridge, the intensity is higher than for most other localities of exposed bedrock. Fallen chimneys and cracks in foundation walls were more prevalent than in most areas so situated.

On bedrock at Point Lobos, also, the effects indicate an intensity pretty close to Grade C, but this locality is nearer the fault than any other Franciscan outcrop save the western slopes of San Bruno Mountain.

We may say in general, therefore, that Grade D is the intensity developed on bare rock foundations, or on rock only moderately coated with soil, in the northeastern part of the city and county of San Francisco.

In the low lands of the valleys, and along portions of the water-front, the sand and alluvial deposits are thicker and the destructive effects were increased in magnitude and in prevalence; also thruout a large part of the sand-dune tract at the west, wherever evidence was obtained, increased intensity was found to prevail.

All over Mission Valley and Hayes Valley, including Upper Hayes Valley, brick walls were cracked and some gables and walls actually fell. Buildings placed on weak underpinning were frequently displaced slightly from the vertical. In a few cases, weak frame dwellings collapsed as a result of the giving way of weak foundation structures. Most chimney stacks were broken. In no part of this large district was evidence of this kind lacking, altho the majority of the structures were fairly substantial frame dwellings, and were of course not seriously damaged. There was much indoor damage, but no investigation of this was undertaken.

At the outer margin of this area, marked by an intensity of Grade C, the destructive effects were weaker, indicating an intensity just above Grade D. Where the district adjoins localities which suffered a still severer shock, the damage was of greater magnitude and more prevalent. Besides this gradation there were, within the limits of the district, several little localities where the characteristic destructive effects were conspicuously numerous.

In the neighborhood of O'Farrell Street, between, say, Mason and Taylor Streets, brick work was sadly cracked. Photographs made before the fire (plate 87A) show that some building fronts were thrown out on O'Farrell Street in this vicinity. Many of the buildings hereabouts were mediocre structures at best, but injuries were too generally distributed to be ascribed wholly to structural weakness. The damage was not of great magnitude and did not indicate intensity of Grade B, so far as could be made out from the ruins after the fire.

Near the City Hall there was a small locality conspicuous for the damage produced. The City Hall itself made a picturesque ruin (plates 82 and 83A), as all the world knows, but the character of the construction was probably a large factor in its destruction. Nevertheless ugly cracks in other buildings near by indicated intensity somewhat higher than was common in the valley district as a whole.

Just south of Jefferson Square some weak buildings quite collapsed, and foundation walls were generally cracked and crushed. Wooden underpinning showed a tendency to lurch and throw buildings slightly out of the vertical. Similar effects prevailed along Folsom and Treat Streets for two or three blocks south of Eighteenth Street.



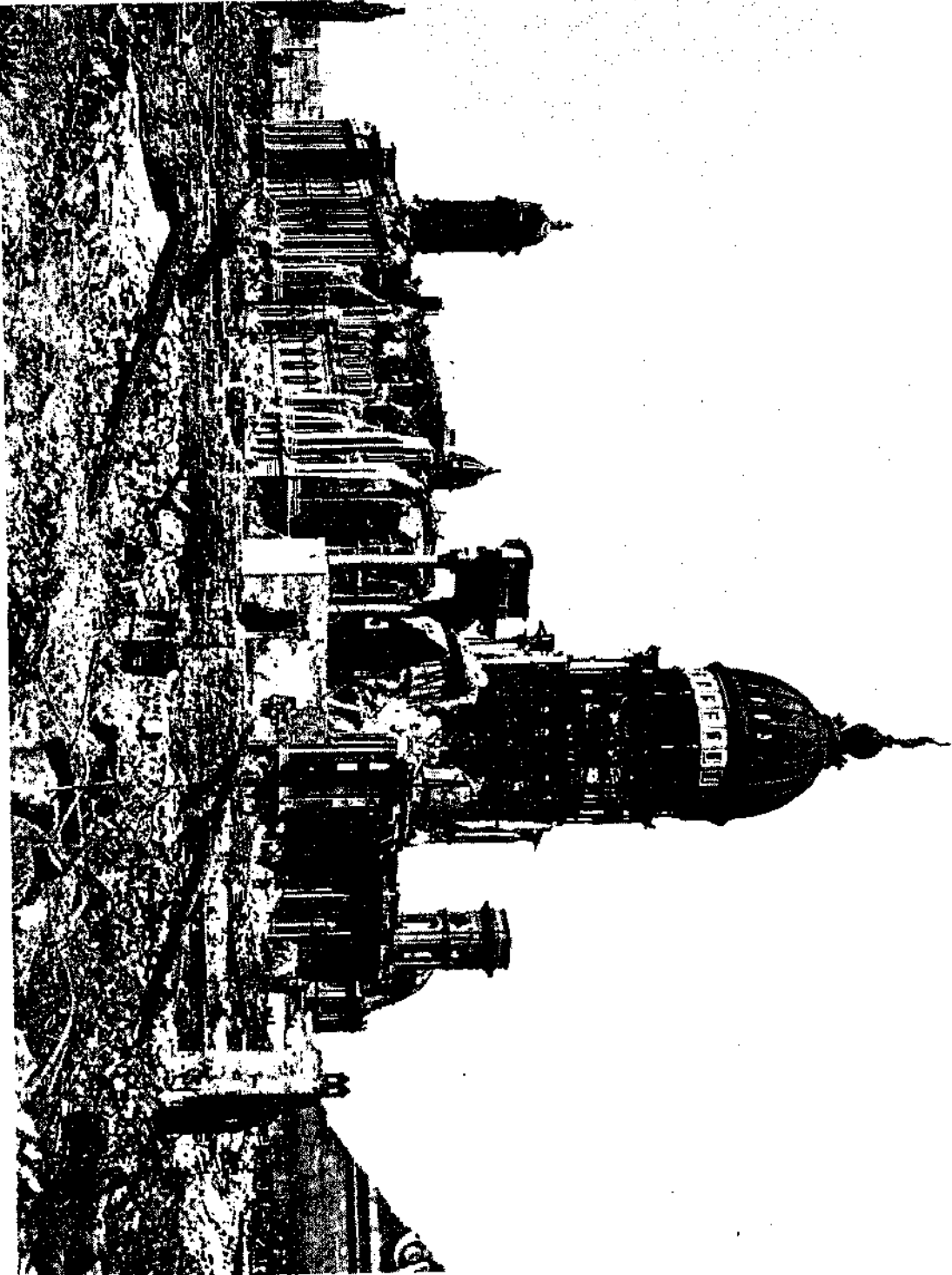

City Hall, San Francisco.



A. A near view of the wreck at the City Hall, San Francisco.



B. Cattle killed by falling masonry at time of earthquake, San Francisco.

The blocks between the old tide-marsh area, extending east from near the Post-office, and the former course of Mission Creek, give evidence in the form of cracked foundation walls, broken concrete cellar floors, etc., of intensity values high in Grade C. The fire did much to destroy evidence here, as it was a district of wooden dwellings.

From near the corner of Third and King, to the corner of Folsom and Steuart Streets, there is a narrow fringe of land constituting the water-front around Rincon Point. The land is partly natural and partly made. Few structures are found on it which are not built on piling, whether they be warehouses on the docks or good modern buildings. Some parts of the area are devoid of buildings. No evidence was disclosed in this tract indicating intensity higher than Grade C. Significant evidence was scarce. Cracked brick walls here and there served to fix the degree of intensity.

Onward to the north and to the west from the corner of Steuart and Folsom Streets, extends a narrow sinuous area around Telegraph Hill to the vicinity of Black Point, which is designated upon the map as affected by an intensity of Grade C. Such effects as badly cracked brick walls, some of which fell, the fall of cornices and gables, etc., are said to have been developed here. Such evidence as could be made out amid the fire ruins tends to confirm this. This region divides the water-front area of made land, where high intensity was developed, from sandstone hills, where a lesser shock was experienced. It will be discussed further in connection with phenomena of special significance.

A low-lying crescent-shaped area of alluvium and sand, with a little made land near the shore, extends westward from Black Point to Fort Point. South, east, and west the hills rise steeply. Formerly a tide-marsh completely separated the alluvial flats from the sandbar at the shore. Part of this, near its mouth, has been filled. Buildings are scantily distributed all over the area. Evidence in the form of structural damage is not, therefore, met frequently. The filled land of the tide-marsh is devoid of structures. There are several little localities in this district marked by damage denoting intensity of Grade B. These will be mentioned later. For the most part, frame buildings occasionally tilted a little out of the vertical, and cracked and crushed foundation walls are typical of the destructive effects found here.

Leading down into this area from near the corner of Polk Street and Pacific Avenue is a minor valley, once deeply trenched, but now modified by alluvial and artificial filling. Along its course most chimneys were thrown and foundation walls were cracked and crushed generally. Two little places, where intensity of Grade B was developed, are situated in the trough. They are discussed below.

A group of small areas, 4 in number, together with a small spur of Mission Valley, situated along a line extending northwest from about the junction of Sixteenth and Dolores Streets, is designated upon the map as characterized by intensity of Grade C. It chances that the northwest extremity of this line coincides with the location of an old fault-zone, mentioned above as partly determining the southwestern limits of the serpentine.

In one of these localities, practically bounded by Maple, Spruce, Washington, and California Streets, brick walls and foundations were cracked conspicuously. A building at the corner of Maple and Washington Streets had a balcony supported by pillars above its front entrance. This was thrown down, and the walls were cracked rather badly. It was probably a structure ill adapted to resist earthquake shock. Still it stands directly upon a bare ledge of serpentine, and upon similar rock in the Potrero, an equal distance from the fault, intensity of only Grade E was developed.

At the corner of Maple and California Streets, the Hahnemann Hospital, a new brick building, sustained severe damage, particularly the east wing. If neighboring structures showed any destructive effects comparable with this, intensity of Grade B would be indicated. But they do not. Some cause peculiar to the building itself is responsible for the exaggeration of the intensity. Probably the newness of the masonry was a contributory factor. The surface material here is sand, but it can not be very thick.

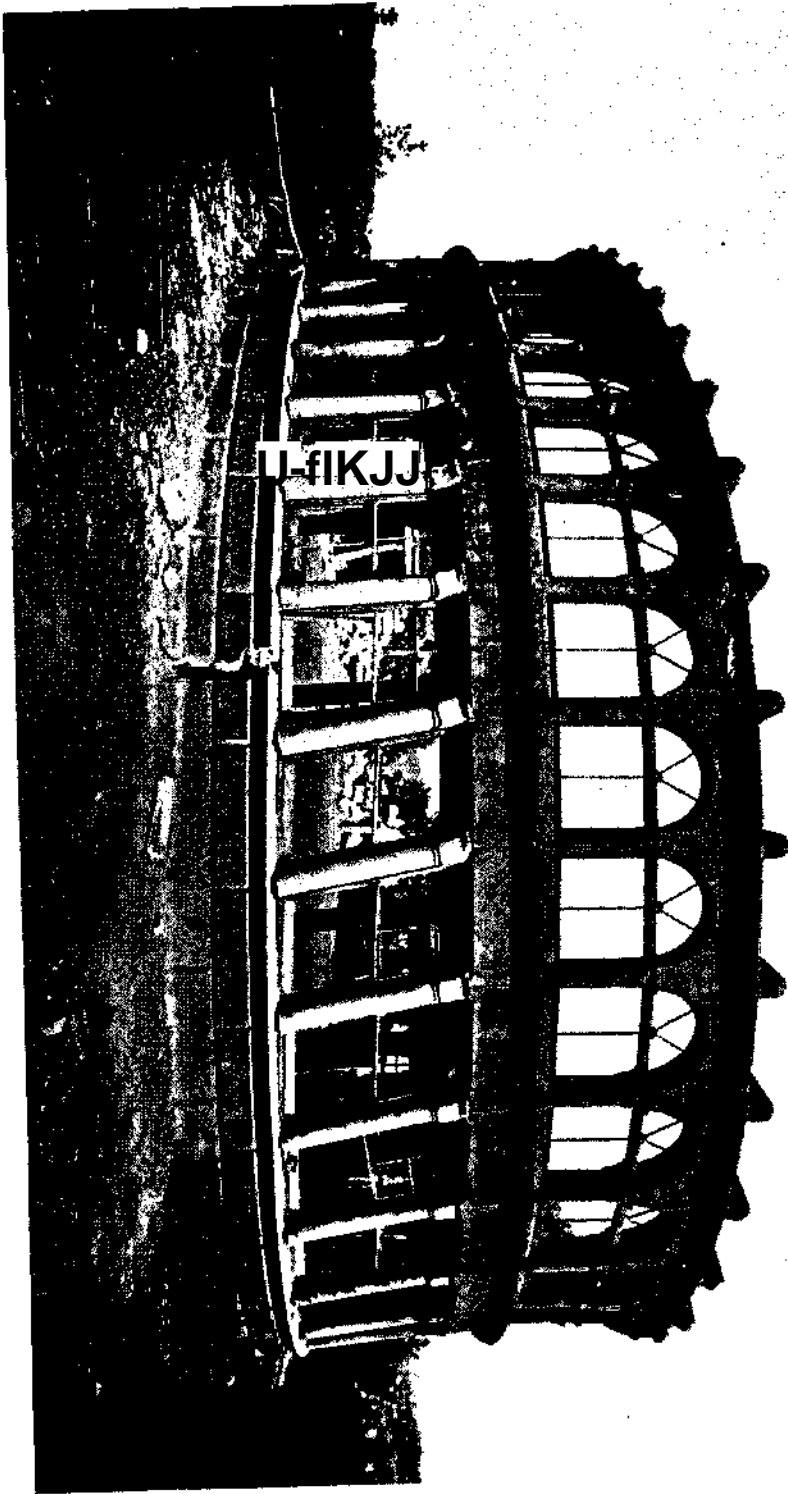

Observatory, Strawberry Hill, Golden Gate Park, San Francisco. W. K. Warden, Photo.

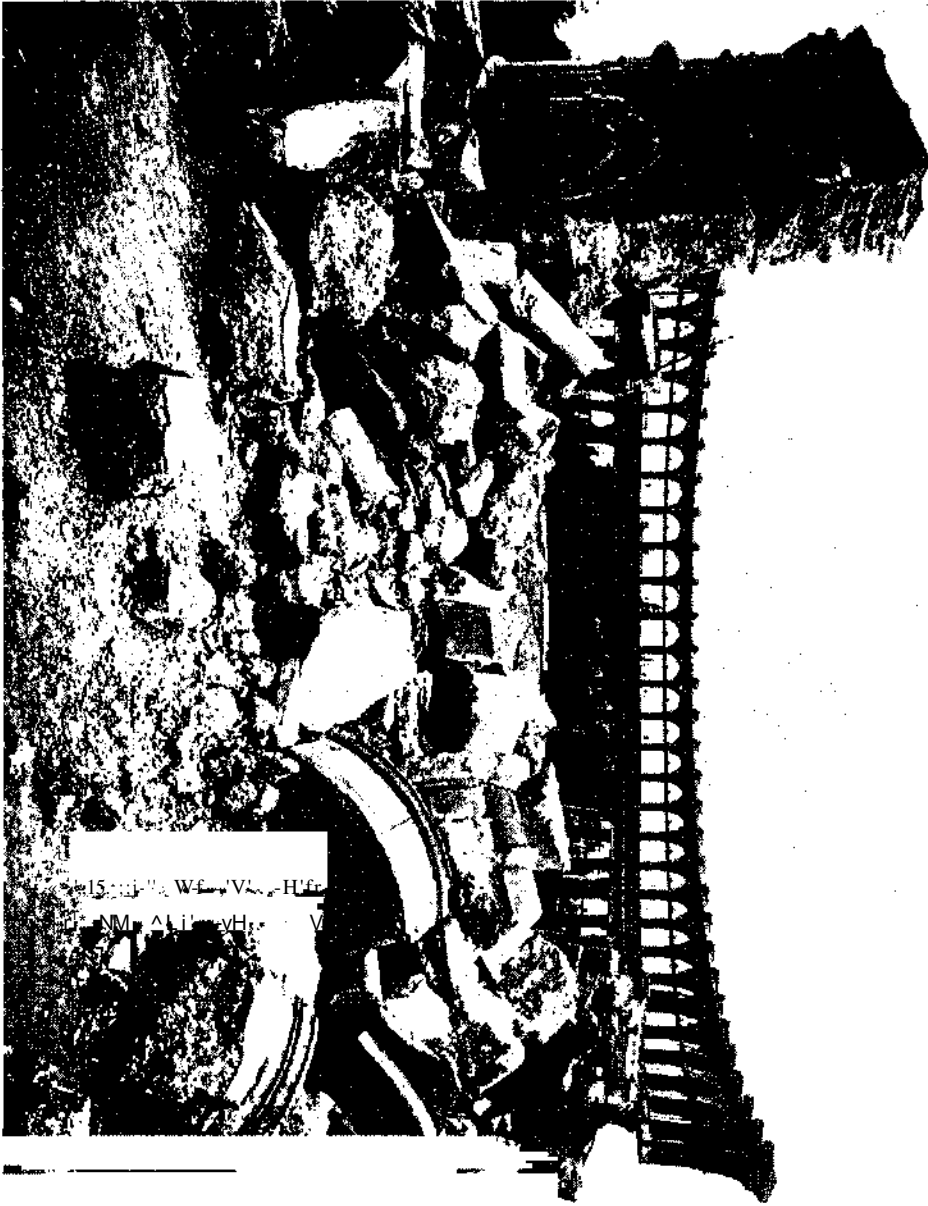

Observatory, Strawberry Hill, Golden Gate Park, San Francisco, W. E. Warden, Photo.

W. E. WARDEN  
O S Y - F W W





Eestaurant at Children's Playground, Golden Gate Park, San Franioisoo, W. E. Worden, Photo.



A. O Tamil Street, San Francisco, after earthquake and before fire.



B. Gearj Street, between FUmore and Steiner Streets, San Fraicisco. Buildings of mediocre onstraotion on sand and allarium of no great depth. A. O. L.

out of place. Two or three smaller buildings in the immediate neighborhood were also notably damaged. Intensity equivalent to high values of Grade C was certainly developed hereabouts. In some cases it undoubtedly reached low values of Grade B. Yet the glass walls and roof of the conservatory, and of the aviary close by, were not appreciably damaged. This discrepancy shows clearly that some purely local factor determined the amount of damage.

Buildings on the beach sands near the Cliff House, close to the sandstone cliffs of Point Lobos, were strongly shaken. A small 1-story brick pumping station had its walls badly cracked and portions thrown down; its chimney stack also was broken. Weak underpinning in some neighboring frame buildings yielded perceptibly. Here also an abrupt transition is noticed from intensity of Grade C on the sands to Grade D on the sandstone cliffs.

Near Lakeview, fairly well built frame buildings on dune sand of unknown thickness were caused to lurch and shift their positions.

Ocean Avenue, between Ingleside and the sea, tho almost devoid of structures, shows by the unearthing, bending, and even breaking of drainage and water pipes, and by fissures in the road and asphalt paving, a change of intensity from Grade C to Grade B.

#### LOCALITIES OF LESSER IMPORTANCE AFFECTED BY INTENSITY OF GRADE B.

In the neighborhood of the crossing of Steiner and Sutter Streets, there is an irregularly bounded district a little larger than a city block in which several buildings not conspicuously weak were totally destroyed. St. Dominic's Church, at the corner of Steiner and Bush Streets, was a complete ruin, as the illustration (plate 92A) shows. Its steeple towers were ruined, its roof fell in, and all its walls were so badly cracked that it became a menace to the neighborhood. If the shock had occurred during the hours of religious service, few would have escaped from the building alive. Probably it was not a building of the most excellent construction; but, on the other hand, it did not appear to be built flimsily. It certainly suffered a most violent shaking. Near by small frame dwellings were pitched from their underpinning.

On Geary Street, just above Fillmore Street, two wooden-framed brick buildings standing side by side — the Albert Pike Memorial Temple (Masonic) and a Jewish Synagogue— were utterly wrecked, as the illustration shows. (Plate 87B.) The Girls' High School, near by on O'Farrell Street, at Scott Street, poorly and flimsily built, was badly damaged. Its walls were much cracked and portions of the gable walls were thrown down.

This district of Grade B intensity is on the floor of Upper Hayes Valley and is surrounded by a relatively broad area in which Grade C effects prevail. It lies near the base of the hills which hem in the valley on the east. The surface strata are sand and alluvium extending to no great depth, unless the slopes of the bedrock hills change suddenly where they pass under the mantle of loose materials. No explanation can be offered for the occurrence of this limited area of high intensity (Grade B) unless it be that the district has been converted into "made" ground by extensive grading in the preparation of the surface for building sites and streets.

At the corner of Vallejo Street and Van Ness Avenue, fissures were formed in the asphalt paving, sidewalk pavements were thrust over the curbing, and water-mains and sewers were broken. Buildings were thrown out of the vertical, and foundations and lower story walls were shifted and crushed. The walls about the foundation of one brick building were actually deformed into undulations with much consequent cracking. This building was so badly damaged that it had to be taken down. Surrounding this corner is a small ovoid district, about 2 blocks in extent, in which the intensity was clearly of Grade B. This was once a sharp ravine and had been filled to a depth of 40 feet in order to provide a



suitable grade for streets and buildings. The filling was shaken together and moved slightly downhill.

On Lombard, between Gough and Octavia Streets, is a little area, less than a block in extent, in which the destructive effects were of Grade B. No particularly notable effects were produced. It is a district of made land, formerly the site of a little lagoon in the sands, known as Washerwoman's Lagoon. A portion of Union Street, between Pierce and Steiner Streets, not more than a quarter of a block in length, where a filling had been made to equalize the street grade, was shaken down into the adjacent building lot on the north. The north sidewalk was shifted about 10 feet to the north, and depressed about 10 feet below its original level. The south sidewalk was depressed a few inches and shifted to the north from 2 to 3 feet. The paving and the cable conduit suffered more severe damage than at any other point in the city. The photograph (plate 88B) conveys a graphic conception of the very great violence which occurred here. The phenomena have no general significance, however, despite their striking character, being merely a sliding of unconsolidated material not supported on the sides. But that such places are dangerous building sites, especially in regions subject to seismic disturbances, is unequivocally demonstrated.

Along the north shore water-front, between Fillmore and Steiner Streets, from Bay Street to the water's edge, was a plot of made ground occupied by a gas-producing plant. Here brick walls were cracked and partly thrown down; part of the wooden framework was wrenched out of position, and the chimney stack was broken. One of the large gas-containers was badly wrecked, but whether its destruction was caused directly or in some secondary way, as by rapid leakage, is not known. The intensity was clearly Grade B.

Along Lyon, Baker, and Broderick Streets, north of North Point Street, is a small locality 2 blocks wide and 4 blocks long, where the Baker Street sewer was broken and frail frame buildings were thrown out of the vertical. This district was partly made land, but the greater part was on the point of a sand-pit. Unquestionably extensive grading had been done to prepare the ground for building.

In Golden Gate Park, near the Museum, the granite railing of a stone-arch bridge was shattered by the shock. This was a low balustrade, with many turned granite posts set closely together, supporting a flat, massive granite top-rail. Such damage as it sustained appears to indicate an intensity of Grade B. The bridge was built on loose sand of no great thickness.

On Fulton Street, between Twelfth and Thirteenth Avenues, there was much slumping of the street-filling down into the Park adjacent; and exactly the same sort of damage occurred on H Street, between Ninth and Fourteenth Avenues. Altho, under the definitions, the damage produced in these localities denotes intensity of Grade B, it is believed that the energy of the shock was not greater than elsewhere in their immediate neighborhoods. They were especially susceptible to damage from earthquake shock, being practically loose earth embankments.

Strawberry Hill, in Golden Gate Park, is a chert knob rising abruptly in the sand wastes. Its summit had been leveled, but it is not known whether this was done by cutting off the top and filling out the upper slopes, or by filling alone. The altitude given for the present hill is the same as that given in the earliest accurate surveys. Much artificial stone work, and a circular concrete observatory building 2 stories high, had been erected upon the leveled hilltop. This building was of weak design, having a row of columns, with windows between, which rested upon a foundation wall 3 feet high and supported a heavy second-story balcony. The construction itself was probably good, but the observatory was utterly ruined by the shock. (Plates 84 and 85.) The entire lower story was sheared out of position, and part of the balcony fell. The cement floor showed numerous cracks arranged in a roughly concentric way.

The whole periphery of the hilltop was broken into a series of concentric blocks or steps, and the outer ones moved down the hill from 2 to 3 feet. The artificial stone work was badly cracked and dislodged. These phenomena indicated that the material used in grading the upper slopes had settled somewhat, with consequent rupture of the surface and wrecking of the building. No other explanation can be urged for such striking damage on this hill, in view of the small damage produced on other rock summits in the city.

All the driveways in the western part of Golden Gate Park showed scattered narrow fissures. There were but few structures here, and they did not show significant damage. These were low, strong, frame buildings. It is a district which was extensively graded in the work of landscape gardening, and is underlain by a deep sand deposit. It appears to have suffered a shock of intensity of the middle range of Grade B.

#### PHENOMENA OF ESPECIAL INTEREST.

About the Ferry Building, at the foot of Market Street, is a district of "made" land, shown on map No. 17, in which high intensity was manifested. Here buildings of all sorts were crowded close together. Wooden buildings, 1 story to 3 stories high, with brick or stone work fronts, were interspersed among ordinary brick buildings from 2 to 6 or 8 stories in height. Mingled with these was a considerable number of modern, class A, office buildings. Here the fire burned fiercely and caused great havoc, heaping the streets and the cellars of buildings with fallen brick and stone and twisted beams and girders. For weeks after the conflagration many of the streets were completely hidden under the débris. So much of the damage due directly to the shock was thereby concealed or obliterated, that no adequate knowledge of the direct effects of the earthquake could be obtained in this part of the city; tho eye-witnesses tell of cornices and gables which fell, and of walls and roofs which collapsed at the time of the shock. After the fire had past, standing walls revealed ugly, sinuous cracks, in rudely parallel systems, which were not due to fire nor to dynamite. Masonry blocks in the walls of excellent modern buildings were broken as by a blow. Rivets were sheared off in parts of the framework of steel structures, and tension rods in such frames were badly stretched. Tubular cast-iron columns, supporting floor girders, were broken off near their bases in cellars where they rested upon piling. The concrete casing of piles was frequently broken. Wherever the intensity was high, the tendency to crack or crush near the base, as tho a sharp blow had been struck there, was notably conspicuous. In spots the streets sank bodily, certainly as much as 2 feet, probably more. Accompanying this depression, concrete basement floors were broken and arched, as if to compensate for it. The surface of the ground was deformed into waves and small open fissures were formed, especially close to the wharves. Buildings on the water side, along East Street, generally slumped seaward, in some cases as much as 2 feet. The damage was greatest close to the water's edge, growing less as the solid land was approached, gradually at first, then more rapidly. These phenomena seem to suggest that the materials used in filling were shaken together so as to occupy less space with the accompanying development of waves, fissures, and structural damage. The more recent the filling, the more it would be compacted; hence the greater prevalence and magnitude of destructive effects near the water's edge.

As well as could be made out from the inadequate evidence left by the fire, the district which suffered intensity of Grade B is limited on the landward side by a line drawn from Filbert Street to Market Street, between Battery and Front Streets; thence between First and Fremont Streets to a little south of Folsom Street, where the line turns and runs eastward to the wharves. Flanking this district on the landward side is a narrow, sinuous area limited by a line drawn from Filbert Street to Green Street, just east of Sansome Street; thence between Sansome and Montgomery Streets to Market Street; thence to the corner of Mission and First Streets; thence between First and Fremont Streets

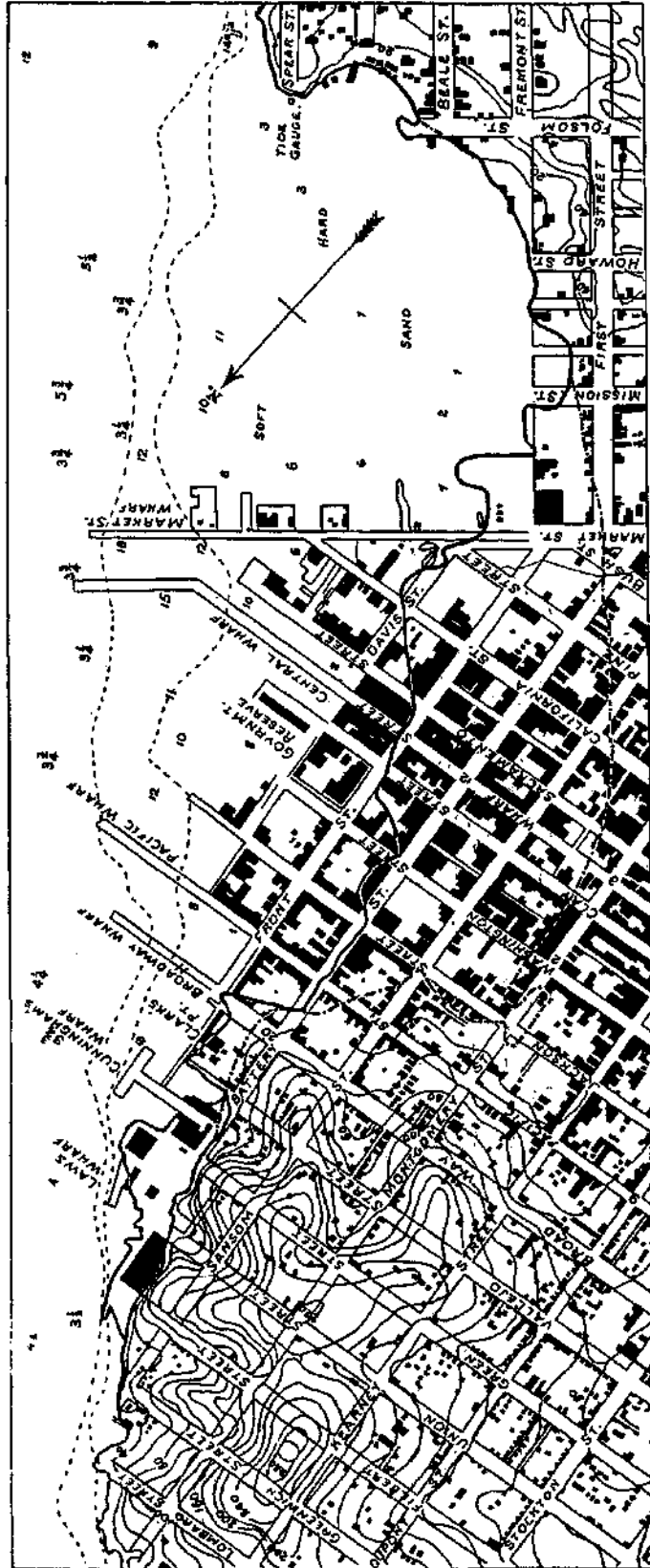

FIG. 51.— Map showing original high-water line of Eddy survey (dot and bar) and mean low-water line or "zero contour" (full line) for district about foot of Market Street in 1853. From Chart of Coast and Geodetic Survey.

to a point south of Folsom Street; thence easterly nearly to the wharves. Between Washington and Sacramento Streets, this boundary is barely east of Montgomery Street. Immediately west of these districts, low intensity prevailed.

It is of interest to inquire whether all or only a portion of this district in which high intensity was developed is "made" land. In the map (fig. 51) is reproduced a portion of the U. S. C. & G. S. chart, "City of San Francisco and its Vicinity," published in 1853 from surveys made in 1851-1852. On it the dot-and-bar line represents the course of the "original high-water line according to plot of Wm. M. Eddy's survey dated 1852." The "zero contour" which determines the configuration of the shore, except where wharves put out, is shown by a continuous line; it is not expressly defined, but it is believed to represent mean low-water, as the soundings are measured from this level. It is needless to point out that this contour is drawn farther seaward than the original high-water line. The portion thus delimited has an area of not less than 20 city blocks, partly or wholly occupied by buildings. Quite outside the "zero contour," as shown on this map, are 8 complete blocks and portions of others — an area of not less than 10 city blocks, partly or wholly built upon. If, then, confidence may be placed in the location of the original high-water line of the Eddy survey of 1852, there were already in San Francisco 30 blocks of "made" land, occupied wholly or in part by buildings before the end of 1853, less than 4 years after the sudden rush to California which followed the discovery of gold in 1849. The revised chart of 1857 shows that very little additional land was made in this district in the succeeding four years.

Without conflicting evidence from other surveys, and no such evidence has been found, the high-water line established by the Eddy survey can not be discredited. Still it is proper to state that these facts raise some doubts as to the accuracy of its delineation, and that the evidence developed by the earthquake does not tend to dispel these doubts. The gradation in the effects produced by the shock, from great magnitude at the waterfront to small at the former land margin, would suggest that at least the marginal district where only Grade C intensity was developed, tho outside the location of the original high-water line, might not be made land, altho it has undoubtedly been somewhat elevated by grading. Very little stress can be laid on this suggestion, however, for these districts suffered very severely in the earthquake shock of 1868; but the materials used in filling were then, of course, shaken together, and in addition, the slow settling together from year to year has undoubtedly compacted the earlier made land much more than that recently "made." Besides, the exhibition of damage depends upon the character of the structures in a given locality, as well as upon the ground, and it is to be noted that the buildings along Kearney, Montgomery, and Sansome Streets comprized a larger percentage of excellent structures than the streets nearer the wharves. The problem is thus complex, and very likely unsolvable; but there remains the haunting suggestion that the "original high-water line" does not constitute the landward boundary of the "made" land, properly speaking. At any rate, it is very clear that that which was known to be "made" land suffered much more severely than that which was known to be natural alluvium.

It is important to recognize that, despite the great intensity manifested near the waterfront, first-class modern buildings, such as the Ferry Building, built upon deep piling or grillage foundations, were not imperiled by injuries to their walls or framework. Some rivets were sheared off; some tension rods were stretched; an occasional girder was dislodged, and cracks were formed here and there in the brick and stone walls. Large financial loss was unquestionably occasioned, but buildings of this type were not in serious danger of collapse nor of being toppled over, either during or after the shock. Nevertheless conservative engineers recognize that even these structures were weakened. They recognize, too, that future shocks may exert greater energy, and they are trying to devise buildings better able to resist the peculiar stresses of earthquake shocks. The

general public should share their interest, and uphold and enforce the provisions they deem it wise to make against future disasters.

A good indication of the value of deep piling as a foundation structure was furnished by the conduits of the cable-car system on lower Market Street. On account of the constant tendency of the whole district to subside from year to year, as the filling material became more closely compacted, these conduits were constructed upon piling to secure permanence of grade. On both sides of them the street sank in places as much as 2 feet, and the pavement was broken, fissured, and thrown into waves. These tracks did not escape entirely, but for several days, before street repairs were made, they constituted a narrow raised path along the center of the street.

Altho in this part of the city the fire did much to conceal the earthquake damage, a few little spots, especially along the water-front, where water was available, escaped its devastation. A building on Spear Street near Folsom, occupied by the National Bolt Works, illustrates what must have occurred in the case of many small brick structures. Its side wall was thrown down and the entire structure lurched out of plumb. To be sure, this building was heavily loaded on its second floor; still it was not so badly damaged as many partly standing walls in near-by districts swept by fire. The earthquake cracks, being sinuous, and recurring with a rude parallelism, were easy to distinguish from cracks opened by heat, or by the stresses induced by the wrenching away of falling walls or by dynamite. Buildings erected upon good foundations withstood the ordeal well, even when the streets around them were deprest and fissured. The Appraisers' Building furnishes a good illustration of this; it is substantially built of brick upon a piling foundation, at the corner of Washington and Sansome Streets, and still stands without significant damage. The levels of its foundation walls were not disturbed. (See fig. 53.)

High intensity was developed thruout a small elongate district having a width of about two blocks, which extends from near the corner of Eighth and Mission Streets to the vicinity of Fourth and Brannan Streets; from this point the boundaries are irregular and very sinuous, leading to the water-front at about the crossings of Third Street with Berry and Channel Streets. A glance at the geological map, No. 17, shows that the regularly bounded portion of this district corresponds very closely with the area of a former tide-marsh, drained and flooded by one or two small tidal streams. The former shore line of Mission Bay was just north of Brannan Street, between Fourth and Fifth Streets, so that the irregular seaward portion of the district lies outside the old shore.

This is one of two localities in the city, the other being a "made" land tract along the former course of Mission Creek, in which destructive effects of great magnitude were conspicuously developed. Only in very close proximity to the fault was greater violence manifested. For blocks the land surface, paved streets, and building plots alike, were thrown into wave forms, trending east and west about parallel to the length of the area. The amplitude and wave-length of these earth billows, and the distances to which they extend, are indefinite and irregular. The fissuring and slumping, and the buckling of block and asphalt pavements into little anticlines and synclines (arches and hollows), accompanied by small open cracks in the earth, characterize the land surface. This slumping movement or flow took place in the direction of the length of the area, and its amount was greatest near the center, or channel, where the street lines were shifted eastward out of their former straight courses, by amounts varying from 3 to 6 feet. A satisfactory photograph of this phenomenon was not obtainable, owing to the quick convergence of parallel lines in perspective, but to the observer in the field it was a very striking result of the shock.

The greater part of the district was occupied by wooden dwellings and shops, with a small percentage of mediocre brick buildings and a few of substantial construction. The fire swept the area clear. Not even heaps of debris remained to cover the ground, most



A. Frame building on west side of Eleventh Avenue, just south of California Street, San Francisco. A weak structure, built on sand. H. O. W.



B. Slip of a fill on Union Street, just west of Steiner Street, San Francisco. H. O. W.



C. Buss Street, between Polk and Howard Streets, San Francisco. Paving blocks forced up into sharp arches and dislodged by compression. H. O. W.



D. Moss Street, between Folsom and Howard Streets, San Francisco. Paving blocks arched by compression along sinuous crest, curbing thrown into an inverted V. H. O. W.



A. Columbia Street, just south of Folsom Street, San Francisco. Slumping, depression, and farrowing of block pavement. H. O. W.

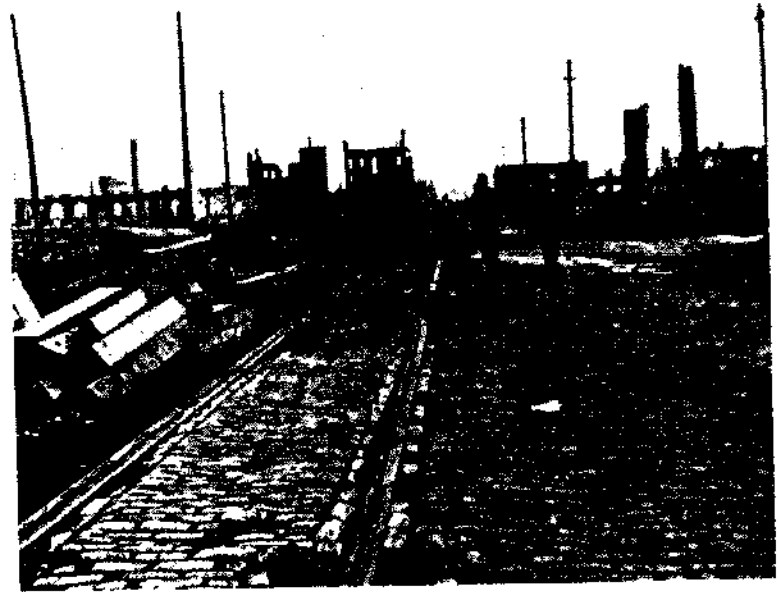

B. Bryant Street, near Fourth Street, San Francisco. Flexure of heavily ballasted car tracks in block pavement; an effect of sharp compression. H. O. W.



C. Sixth Street, near Howard. Once occupied by marsh. Street dropt nearly 3 feet. Sidewalk held up by piling foundation of a building. H. U. W.



D. Looking along Dore Street, from Bryant toward Brannan. Undulating and fractured condition of pavement due to earthquake. Houses thrown off their underpinning and pitched out of the vertical. H. O. W.



A. Looking along Dore Street from Brannan toward Bryant, Larger undulations near Brannan, Dore Street is on site of an arm of Mission Creek. H. O. W.



B. Dore Street, near Brannan, Vertical difference between crest and trough of undulations, 5 feet. H. O. W.

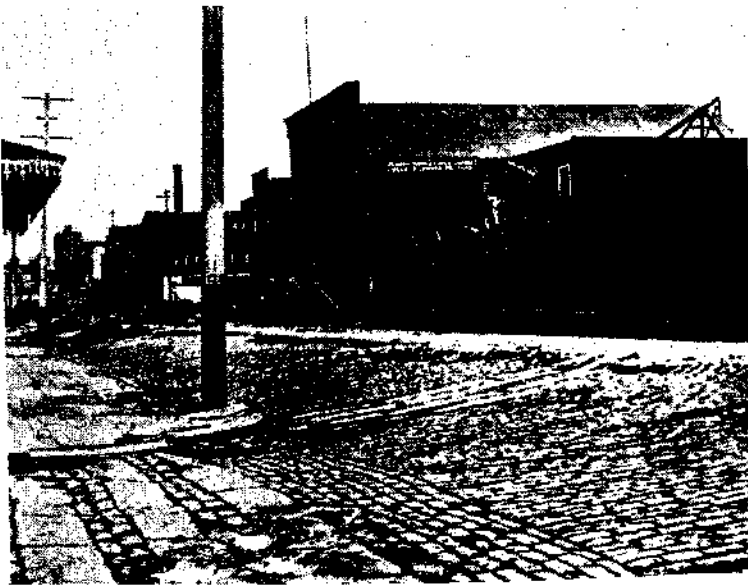

C. Eighteenth Street, just east of Shotwell, Fissuring and depression of Pavement. H. O. W.



D. Southwest corner Portola and Waller Streets. Buildings have shifted down hill slightly, upper parts more than lower. H. O. W.



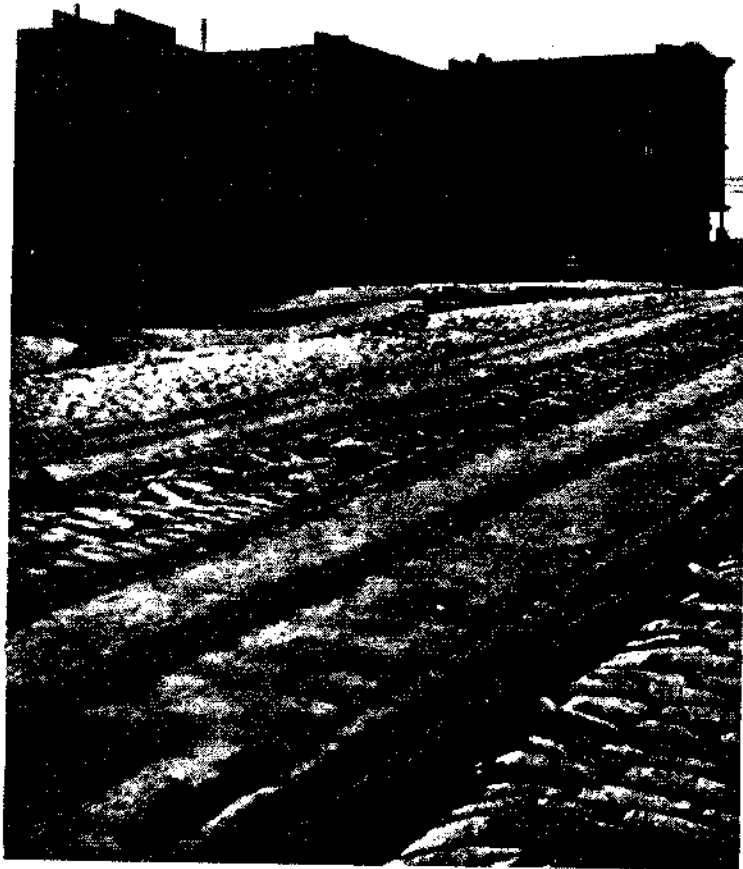

A. Ninth Street, between Bryant and Brannan. Undulation and flssuring of pavement and sidewalks. Houses over trough have been dropt from their underpinning. G. K. G.

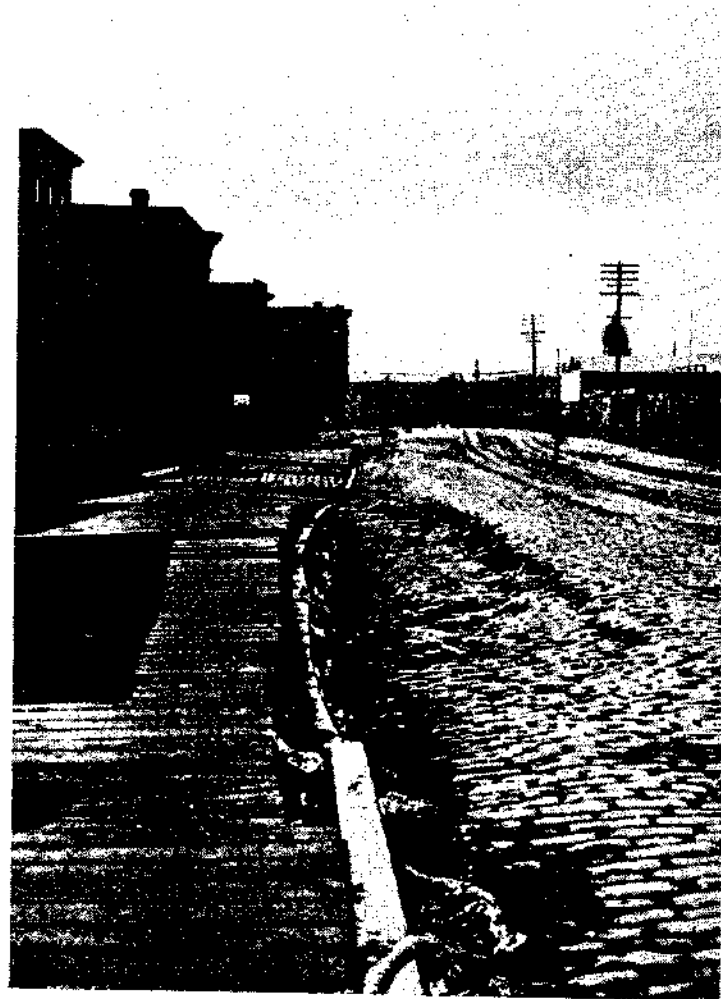

B. Ninth Street, between Bryant and Brannan. Westward lurching of land toward former creek channel where Dore Street now is. G. K. G.

of the destructive effects being obliterated, along with the structures in which they were developed. Enough remained, however. Foundation walls and sidewalk pavements were broken and flexed; sharp little anticlines were produced in the street by the arching of block paving, as on Russ Street between Folsom and Howard Streets (plate 88c); granite curbing was broken and thrust up into an inverted V, as on Moss Street, between Folsom and Howard Streets (plate 88D); there were fissuring and slumping in the block pavement, as along Columbia Street between Folsom and Harrison Streets (plate 89A), and sharp flexures of the paved streets and car tracks, as on Sixth Street just south of Howard Street. These effects point simply and clearly to the great magnitude of the intensity thruout the greater part of this old swampy district.

Attention has already been directed to the slumping or flow movement to the east along the long axis of the area.

The heavily ballasted car-tracks on Bryant Street, at the crossing with Fourth Street, were sharply flexed laterally, tho bounded by block paving. (Plate 89B.) This was at the eastern end of the district where the marsh formerly bent to the south around the flanks of Rincon Hill, a mass of firm sandstone rising from the floor of Mission Valley. No similar sharp flexures were encountered along east-west streets in the western or central portion of the district, tho lateral displacement and flat, sinuous curvings of the street lines were common enough; notably on Harrison Street between Fifth and Sixth Streets, and on Folsom Street between Fourth and Seventh Streets. Both these streets cut across the direction of the flow movement at a small angle. These phenomena are easy to understand if, as seems certain, Rincon Hill served as a solid buttress against which the flow to the east was arrested, causing sharp crumpling of the surface near the buttress, with less disturbance farther away. This was combined with a slight tendency to flow southward in the southeastern part of the district.

The shaking caused the materials used in filling to settle together and occupy less space, so that the surface over the whole district was lowered by amounts varying from a few inches to 3 feet or more. This is clearly seen in the change of street levels along the margin of the solid ground, where the car rails are bent downward in little monoclines. Occasionally a structure with a relatively good foundation remains at its former level, with the whole neighborhood deprest about it. Such a case is exemplified on Sixth Street, a little south of Howard Street, near the margin of the area. (Plate 89c.) The flow movement is thought to be due simply to the action of gravity, the loose, water-soaked material being compacted into less volume by the shaking. Besides this sinking of the district, and its flow movement, mention has been made of the deformation of its surface into irregular waves, trending approximately east and west parallel with the length of the district. Along the streets running approximately north and south, at right angles to the elongation of the area, car rails were bent abruptly to the side, or raised in arches, and sharp anticlines were formed in the block pavements. Large square concrete slabs, used for sidewalk paving, were thrust one over the other; and in one or two cases a slab entirely covered an adjoining one. These phenomena indicate shortening by compression in the north-south direction. On the other hand, however, a stretching of the surface is shown by fissures in the paving; by places where wedge-like blocks were deprest below the general level; and by the rails of car tracks which were pulled apart in amounts varying from 8 to 12 inches. Owing to the relatively great and very variable structural strength of paved streets and heavily ballasted car tracks, these phenomena are not developed regularly nor frequently enough to afford a satisfactory test of the hypothesis that they are directly associated with the wave forms into which the surface of this district was thrown. Besides, owing perhaps to the varying rigidity of the materials which make up the surface of the streets and building plots, the wave forms themselves, tho generally prevalent, are not persistent in their extension. The compression and (listen-

sion effects, however, are believed to be due to the same cause as that which generated the wave forms; for there is no evidence of any true shortening, or lengthening, of the north-south dimension of this district, nor is there any probability of this having occurred.

In addition, then, to the flow movement and the settling together of the loose materials causing depression, there was some sort of rhythmic movement in this loose earth which produced wave forms in the surface, with places of compression and places of stretching. It probably was this movement which was most effective in producing structural damage. It is not believed that these surface waves were traveling waves "frozen" as the shock subsided. If they had been of that character, the ground surface should be more broken than it appeared to be; for in relatively rigid materials such waves must develop open fissures along the crests, which would close with crushing in the troughs. It must be noted, without any attempt at explanation, that the destructive effects of great magnitude which have been described above, are practically confined to the "made" land which occupies the old marsh site.

Southeast of Brannan Street, where formerly lay Mission Bay, such effects are of less magnitude, in general; are less regular in their occurrence and are, on the whole, less prevalent. The complete devastation caused by the fire in this neighborhood leaves little to indicate the actual damage to the buildings wrought by the earthquake. Certain hotels or apartment houses are known to have collapsed, and many fatalities must have occurred. Probably a few dwellings were thrown down. A fairly large percentage of the buildings, one must believe, were rendered dangerous for occupation, even tho not completely thrown down.

The new United States Post-office building (plate 94B), at the corner of Seventh and Mission Streets, was just on the margin of the district. It is a steel and granite structure, resting upon a foundation of piling driven to a considerable depth, but not as far as some had considered advisable. At its southwest corner, the streets are deformed into great waves, some with an amplitude of at least 3 feet, causing fissures and sharp compressional arches in the pavement and sidewalks. Some of the granite flanking structures, which did not rest upon the pile foundation of the building, shared this undulatory movement. In consequence, the building appears badly damaged to the casual observer. It is quite true that the structure was terribly shaken and greatly damaged — such injuries as the destruction of mosaics in the arches of the corridor helped to increase the loss — but the structure was not in peril of collapse, tho one of the low walls had to be supported by timbers. For the most part, the building survived the ordeal, and is in a safe condition for use.

As stated briefly above, a similar district of high intensity occurs in an area of made land along the lower portion of the former course of Mission Creek. This district varies in width from 1 to 2 blocks, extending from near the corner of Ninth and Brannan Streets westward for about 3 blocks, then southwestward for about 2 blocks more; and finally, westward some 4 blocks more to a point on Nineteenth Street just east of Dolores Street.

Mission Creek was formerly a sinuous tidal stream, with narrow fringes of salt marsh about its banks. Near its mouth the stream wound around a rocky point where the serpentine hills of the Potrero rose abruptly from its southern bank. Here, along its margin, is found the most sudden transition from high to low intensity that is anywhere encountered in the city. Along Dore Street, a narrow alley running from Bryant Street to Brannan Street, between Ninth and Tenth Streets, the street pavement was broken into a series of waves. The photographs, plate 89D, looking along Dore Street from Bryant toward Brannan Street; plate 90A, looking from Brannan Street in the reverse direction; and plate 90B, showing in detail the trough of one of these waves, with the fissuring of the pavement near the farther crest, indicate more clearly than words the great intensity manifested here. Less than 2 blocks south on the hill slopes, more than

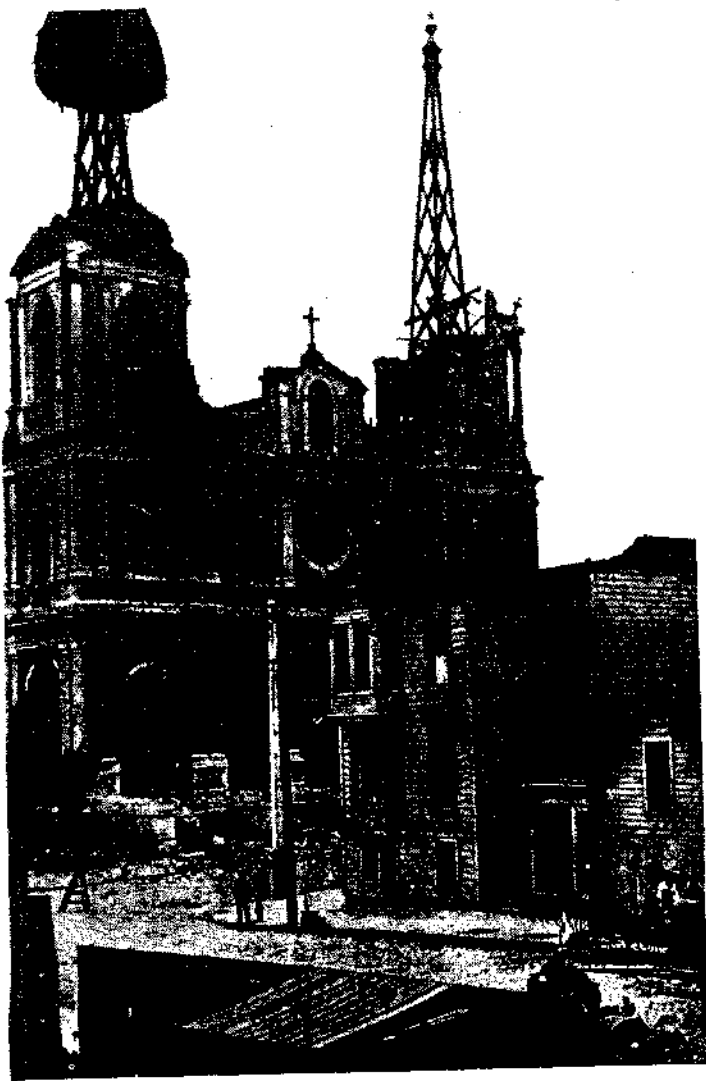

A. St. Dominic's Ochoa, Bush and Steiner Streets. Brick and masonry structure upon sand and alluvium of no great depth. A. O. L.



B. Looking south on Howard Street from near Seventeenth Street. Compression and flexure of car rails. G. K. G.

50 per cent of the chimneys were left standing, and no serious structural damage was noted. No comment seems needed to establish clearly the fact that the change in the character of the ground, this being the only variable factor, is in some way the cause of the change in the degree of intensity.

On Ninth Street, east of Dore Street, between Bryant and Brannan Streets, the block pavement was badly damaged by fissuring, slumping, and the formation of surface waves. Frame dwellings were thrown from their underpinning, and a few collapsed. Plate 91A shows a wave trough near Bryant Street, with the resulting disturbance of the pavement. The dwellings immediately in the trough have dropt from their foundation posts. In plate 91B, looking along Ninth Street from near Brannan Street, is shown the depression and fissuring of the street and its slumping or flow westward toward the former channel of a short branch of Mission Creek, which occupied the present location of Dore Street. Streets, curbing, car tracks, etc., are deflected from 6 to 8 feet from their former positions. The frame dwellings were not destroyed, but a careful examination of the picture will show that most of them are badly injured. Many were left in a dangerous condition by the shock.

On Tenth Street, between Bryant and Brannan Streets, less violence was noted and the slumping of flow eastward (toward the channel of the little branch of Mission Creek) is scarcely noticeable.

Again, along the creek bed from Folsom Street, between Seventeenth and Eighteenth Streets, to the vicinity of Valencia Street at Eighteenth, great destruction was conspicuously prevalent. Less than a third of the frame dwellings in this tract retained their vertical positions, and a few collapsed completely. Others remained standing only by leaning against each other. The south side of Howard Street, between Seventeenth and Eighteenth Streets, which escaped the fire, furnishes a good illustration of the damage produced here. (See plate 93A.) AS in other places, the streets were deprest, fissured, and thrown into waves. (Plate 90c.) Car rails were arched and bent laterally in a violent fashion. (Plate 92B.)

Sewers and water-mains were broken. At Eighteenth and Valencia Streets there was a serious break in the water-pipe. Here, on both sides of the street, the ground sank about 6 feet, causing the roadway to arch in a very noticeable way. (Plate 93B.) Ten-inch car rails were bowed up into arches from 24 to 30 inches in height. The Valencia Street Hotel collapsed so that occupants of the fourth story could step out into the street. Casualties in this district can never be known accurately, owing to the immediate onset of the fire, and the complete devastation it produced.

On land made by filling in, "The Willows," a marshy tract formerly extending up the Eighteenth Street Valley from Mission Lagoon, near the corner of Nineteenth and Guerrero Streets, there was observed a considerable slumping or flow movement of the surface. The photograph (plate 94A) shows the Youth's Directory, a charitable institution for boys, where the street and building were moved northward and slightly eastward, toward the former channel and downstream, fully 6 feet.

Enough evidence has been cited to demonstrate that high intensity prevailed thruout this district. Here, as in the other tract of made land which occupies the site of the old tidal marsh, the materials used for filling were shaken together, and caused a general depression of the surface over the whole district, accompanied by slumping or flow movements. The surface was deformed into waves, with accompanying fissures and sharp compressional arches. Hero too, as in the tract previously described, the materials used for filling constitute a relatively thin rigid layer deposited upon the marshy fringes or in the shallow waters of the creek.

The creek (see map No. 17) formerly extended for about 2 blocks eastward from Ninth and Brannan Streets before it reached the old shore line of Mission Bay. This portion

of its course is now occupied in large part by the railway tracks and structures of the Southern Pacific Company; and the exceptionally strong foundation necessarily provided for the railway line probably explains why less damage was found here than one would at first have expected. At any rate, the greatest damage noted was the cracking of brick walls and the falling of cornices.

The space formerly occupied by Mission Bay has been partly filled to provide building sites, and of course the materials used in filling were deposited in water. The district is occupied in part by structures of great strength, such as railway tracks; in part it is devoid of buildings. Thruout the district, evidence was insufficient and inconclusive. Except near the former outlet of Mission Creek, and in the area further north formerly occupied by the tidal marsh, the destruction produced does not denote intensity higher than Grade C. Apparently, therefore, land made by filling up spaces of open water is less dangerous, on the whole, than land made by depositing a thin rigid layer of filling upon a tract of marsh land. This, at least, is the lesson in San Francisco. The reasons for it are not very clear. Space forbids a discussion of theories which can not be adequately tested. It may be noted, however, that much of the material used in filling in areas of water has been broken rock derived from the grading down of neighboring rocky hills.

Near the corner of "Waller and Portola Streets, not far north of the head of Market Street, is a locality, less than a block in extent, where houses were shifted slightly on their foundations; their upper stories were moved farther eastward (downhill) than the foundations, as a result of shearing in the framework of the basement or of the first story of the buildings. (Plate 90D.) There also occurred minor bucklings and breaking of the thin asphalt pavement. The intensity, which belongs low in the range of Grade B, diminishes rapidly in all directions, and the district is surrounded by a band where the intensity is Grade C. Here a thin layer of sand reposes upon the slopes of a little upland valley between the low serpentine hills to the east and the high chert hills to the west. The effects are such as would be produced by a shaking downhill of this thin sand layer, with the structures which rest upon it. This seems the best explanation of high intensity in this district. Attention, nevertheless, must be directed to the fact that this, and three other districts shown on the map, No. 19, lie roughly along a straight line which nearly coincides with the western boundary of the serpentine body. At its northwest end, this boundary is known to be determined by a fault of considerable throw, constituting consequently a weak place in the crust of the earth here. It is not known how far southeast the fault extends, and it is not unlikely that it cuts entirely across the peninsula. The recurrence of these little districts of comparatively high intensity suggests that it continues as far south as Market Street, at least, and that such a zone of weakness was especially suited to the production of high intensity by the shock. This hypothesis can not be conclusively tested, but it is interesting and important enough to merit presentation and to receive attention in the event of future earthquakes.

In support of the statement made in the foregoing pages that the intensity increases markedly as one approaches the fault, independently of the character of the ground and other factors, the following evidence is presented:

Forty-eighth Avenue, between K and N Streets, is a district underlain by deep sand where extensive grading operations were undoubtedly necessary to convert an area of sand-dunes into streets and building lots. Here small, substantial frame dwellings were shifted bodily from 1 to 2 feet out of position, and the streets were slightly dislocated. Telegraph poles were thrown down or caused to lean over so much that only the tension of the wires kept them from falling completely, and lamp posts were overthrown. The dwellings suffered little structural damage, owing to their small, substantial character, and to their being built close to the ground; so that when shifted from their underpin-



A. East side of Howard Street, between Seventeenth and Eighteenth Streets. A. O. L.



B. Valencia Street, near Eighteenth. Sink in neighborhood sunk about 8 feet, along street into\* A.O.L.



A. View along Nineteenth Street, from Guerrero Street. Both ground and buildings moved north about 6 feet toward center of old marsh, with component of movement down the channel. A. O. L.

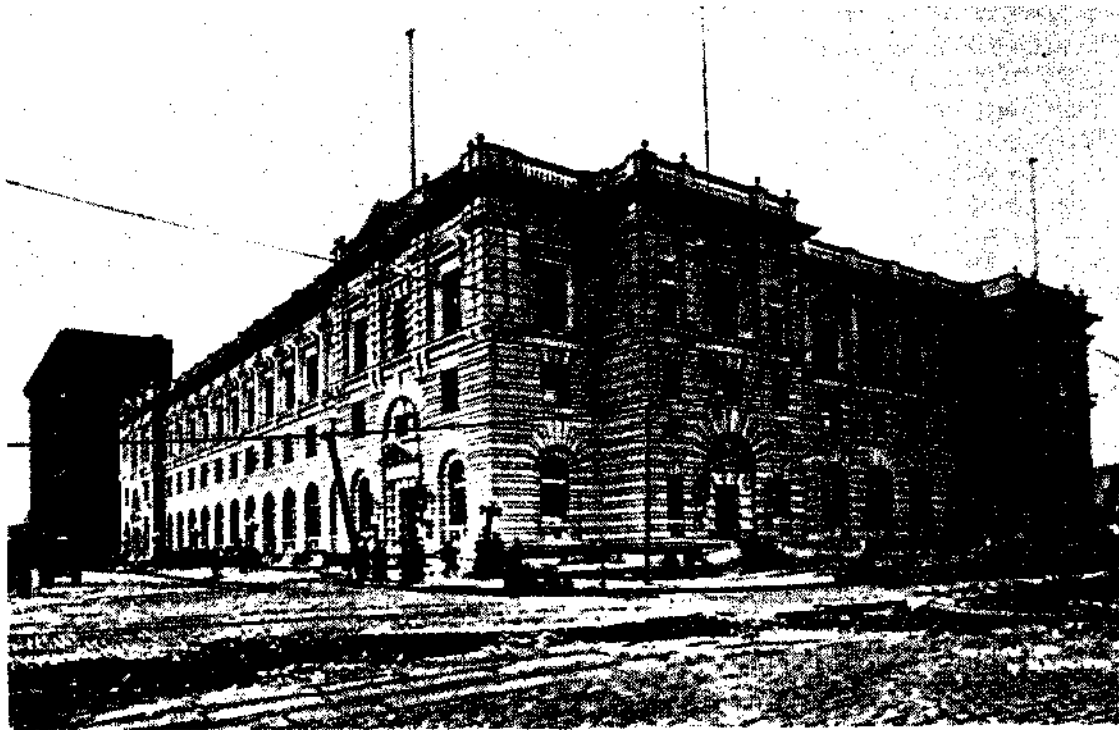

B. San Francisco Post-office, Mission and Seventh Streets. Corner of building is on edge of old marsh. Ground over marsh sank and inhaled. W. E. Wordsworth, Photo.



ning, they had but a few inches to fall. Still, it is the opinion of the writer that the intensity developed here was little, if any, short of the maximum on the made land in the city, tho the conditions were not such as to permit so great damage.

On Ocean Avenue and X Street, near where the former outlet of Lake Merced flowed, fissures were developed in the street and in the sands on either side, and water was squeezed out so as partly to flood the roadway. Drain pipes were unearthed and bent or twisted.

From the former outlet of Lake Merced, where W Street meets the Grand Ocean Boulevard, or Great Highway, southward along the ocean, low cliffs of soft rock — the Merced sandstones and shales — rise abruptly from the beach. These mount gradually as we go southward, until at Mussel Rock they attain a height of 500 feet. AH along this line of cliffs, and for a short undetermined distance inland, the rock masses were cracked, broken, and traversed by narrow fissures. These effects grow more and more numerous and of greater and greater magnitude until, a short distance north of Mussel Rock, the fault is reached. A short distance south of X Street, a small, substantial frame dwelling, built upon a good foundation under the cliffs by the beach, was almost overturned. South of this there were no structures along the beach except the seaward end of the Lake Merced Tunnel, an hydraulic arch which was slightly broken, tho embedded in the rocks of the Merced formation. All along the faces of these cliffs, much material fell or slid down to the beach.

#### CONCLUSIONS.

This investigation has clearly demonstrated that the amount of damage produced by the earthquake of April 18 in different parts of the city and county of San Francisco depended chiefly upon the geological character of the ground. Where the surface was of solid rock, the shock produced little damage; whereas upon made land great violence was manifested. Other things being equal, there was a decrease of intensity from the southwest toward the northeast, as the distance from the zone of faulting increased. Other conditions, however, exerted a controlling influence. There was, for instance, much greater contrast, in the destructive effects produced, between the summit of Telegraph Hill and the vicinity of the Ferry Building, about a quarter of a mile apart and at practically the same distance from the fault, than there was between the damage produced near the Ferry Building and along the trace of the fault itself. (Consult the intensity map and profiles.) In this part of the zone of destruction, change in distance from the fault clearly did not influence the gradation in intensity, so much as did change in the character of the ground.

#### ADDENDA.

*Subsidence of made land.*—The unstable character of the made land on the waterfront of San Francisco has long been known. This instability made itself manifest in a progressive subsidence which, in the course of years, rendered it quite difficult to maintain the grade of the streets. An effort was made by Mr. G. E. Grunsky, when he was city engineer, to determine the rate of this subsidence, and the following extract from his report as city engineer for the year 1902-3 is not without interest in connection with the violent disturbance of the ground caused by the earthquake in the areas of made land:

Examination has again been made to determine the amount of sinking in those improved portions of the city where subsidence has heretofore been observed. The result of this examination appears from the following table, in which is also given the subsidence which occurred during the preceding year.

Street.	From—	To—	SUBSIDENCE IN FEET.			
			April, 1901, to April, 1902.		April, 1902, to April, 1903.	
			Max.	Mean.	Max.	Mean.
1. Davis. . . .	Market . . .	East . . . .	.07	.05	.08	
2. Jackson . . .	Montgomery	East . . . .	.07	.03	.06	
3. Spear. . . .	Market . . .	Bryant . . .	.10	.06	.05	
4. Mission . . .	First. . . .	East . . . .	.11	.07	.05	.02
5. Harrison (a)	Fourth . . .	Seventh . . .	.17	.15	.22	.19
6. Sixth . . . .	Howard . . .	Channel . . .	.10	.05	.17	.08* •05§

(a) Location of maximum subsidence on Harrison Street between Fourth and Seventh is the same for both years.

\* Mean subsidence from Brannan southerly.

§ Mean subsidence from Brannan to Howard.

1. No appreciable subsidence (Apr. 1902-Apr. 1903) except at Vallejo Street, where maximum occurs.
2. No appreciable subsidence (Apr. 1902-Apr. 1903) except at Drumm and East Streets, where maximum occurs.
3. No appreciable subsidence (Apr. 1902-Apr. 1903) except at Mission Street, where maximum occurs.
4. Subsidence (Apr. 1902-Apr. 1903) occurs from Main easterly; maximum at East Street.
5. Subsidence (Apr. 1902-Apr. 1903) occurs from a point between Fourth and Fifth Streets, as far west as Sixth Street.
6. Maximum (Apr. 1902-Apr. 1903) at Folsom Street.

*Possible premonitory movements* (Miss H. C. Lillis). — Mr. McConnell, a jeweler, located on Post Street between Montgomery and Kearney Streets, states that 4 days before the earthquake he found one of his windows broken in nearly 50 pieces tho none of the pieces had fallen out; and supposing that some one had tried to enter his shop, he sent for a detective. Captain Calunden came, and on looking over the premises declared that it was not the work of a burglar but was due to the settling of the building. He found the building out of plumb. This would indicate a settling of the ground before the shock. One of his workmen who lived in the Mission found his cellar door closed so that difficulty was experienced in opening it. This occurred the same day as that on which the glass was broken.

*Effect of the shock near the beach* (W. D. Valentine). — We were residing on Forty-eighth Avenue, between K and L Streets, within a few hundred feet of the ocean, about 0.5 mile south of the park. In our section the shock was violent. It awakened me instantly, and for a few seconds I was unable to rise, as I was thrown back in the effort. Meanwhile I was carefully watching the movements of an extremely tall and heavy oaken wardrobe which stood almost in the middle of the floor. The top first swung to the west, then to the north, then to the east, and fell directly to the south with such force that it went to pieces. Our heavy upright piano and various heavy articles of furniture were thrown completely over. The sand in our basement raised from 1 foot to 15 inches. A wide and long 3-foot depression was raised level. Our lot, which was 120 feet deep, was shortened at least a foot, which was shown by the folding of the fence. Electric-light poles in the street in front of us, which were in the sand, were thrown down north, east, south, and west. There was a fissure for about a block, between Forty-seventh and Forty-eighth Avenues, about 3 feet wide and 0 or 8 inches deep,

which was of course in the sand. There were also other blow-holes in the sand, which emitted water and sulfurous odors.

*Effect of the shock on the gas plant and pipes* (E. C. Jones). — The earthquake movement was apparently from north to south, inferred from the fact that bookcases and china closets placed east and west were almost invariably tipped over, or their contents thrown out; while those placed north and south were in most cases undisturbed. Gas-mains in streets running east and west were broken and drawn apart, while those in streets running north and south were crushed together and telescoped, or else raised out of the ground in inverted Vs. This rule applied generally, with but few exceptions.

On Jackson Street, between Drumm and Davis Streets, which is made land, the street main was laid on a line of piles which went to hard pan. The piles were not purposely driven to sustain the pipe, but happened to be in the line of the main when it was laid. This pipe broke over the center of each pile, 9 in number, and was not broken in the made ground where it was unsupported.

During the latter part of the first shock, there was a rotating motion which had the effect of twisting gas-holders out of their guide frames.

The foreman of the North Beach Station was looking at the 2,000,000-foot storage holder, and described it as follows:

On going to the window, I looked at the storage holder, which was vibrating like an inverted pendulum, and waves of water were coming over the wall of the tank. The relief holder was similarly affected with water and tar coming over the tank wall. The shrubbery in the garden was shaken as though by a strong wind.

These two holders were heavily framed with latticed girders, and did not leave their guides by the rotating movement of the earthquake.

The storage holder at the Pacific Gas Improvement Company's Works was twisted around 2 feet from the guide rails, while at Martin Station the 1,500,000-foot storage holder was twisted 5 feet on the lower section, 8 feet on the middle section, and 12 feet on the upper section. At this plant the 4,000,000-foot generator was moved bodily 2.5 inches to the south. All connections were of steel, and no joints were broken.

A barn at the North Beach Station, corner of Laguna and Bay Streets, was resting upon wooden uprights about 16 inches high. These uprights were tipped over, and the barn moved the length of the uprights toward the south; that is, after the earthquake it stood 16 inches on the sidewalk.

The buildings at the different plants did not suffer according to their relative strength. Some brick buildings of comparatively poor construction were unharmed. Other buildings of great strength, with heavy footings on good foundations, were shaken to the ground, particularly those running east and west; while buildings of the same or less strength, with foundations not so good, but running in a direction north and south, were but little injured.

*Effect on certain street railways* (T. Mallally). — There does not seem to have been any actual shortening of the length of the street railways of the United Railroads of San Francisco; but the rails in one location traveled about 3 feet in a northerly direction. This location was in the valley and was marsh land, beginning at a point about 100 yards north of Holy Cross Cemetery, where the rails parted, and ending about 1,000 yards north of Holy Cross, where the rails buckled up in the air. We had to cut out about 3 feet at this point, and add 3 feet where it parted at the other end. Of course there was a decided movement of the rails all along, in a lateral direction, which left the tracks out of alignment, but was not enough to prevent operation of cars.

This condition would indicate that the fill in the marsh land moved in a northerly direction about 3 feet, but that the actual distance along our line has not been appreciably changed.

*Deformation of the U. S. Government buildings.* — For the purpose of determining the extent of the deformation of the three U. S. Government buildings — the new Post-office, the Appraisers' Building, and the Mint — the Coast and Geodetic Survey, at the request of the Commission, determined on July 12, 1906, the relative levels of the four corners of each of these structures, as indicated in the accompanying notes and figures. The leveling was done by Mr. C. H. Sinclair. The memorandum of Mr. Sinclair's results, which was placed at the disposal of the Commission by the Superintendent of the Coast and Geodetic Survey, is as follows:

*New Post-office.* — Fig. 52 shows by numbers the positions of the stations occupied; and the points at the corners, the relative levels of which were determined, are indicated by their orientation.

The southwest corner is the lowest and is the only one that settled materially, being about 0.393 foot = 4.72 inches lower. The outer walls have cracks in many places. This is a fairly good showing for a bad foundation.

Sights nearly equal except at II, where backsight is about 100 feet and foresight is about 300 feet. Street so low that readings could not be made any other way. Cars and drays passing all the time. Wind bad. Rod held on circular molding (tower, | circle section) which was the lowest projection built into the wall that was common to the four extreme corners.

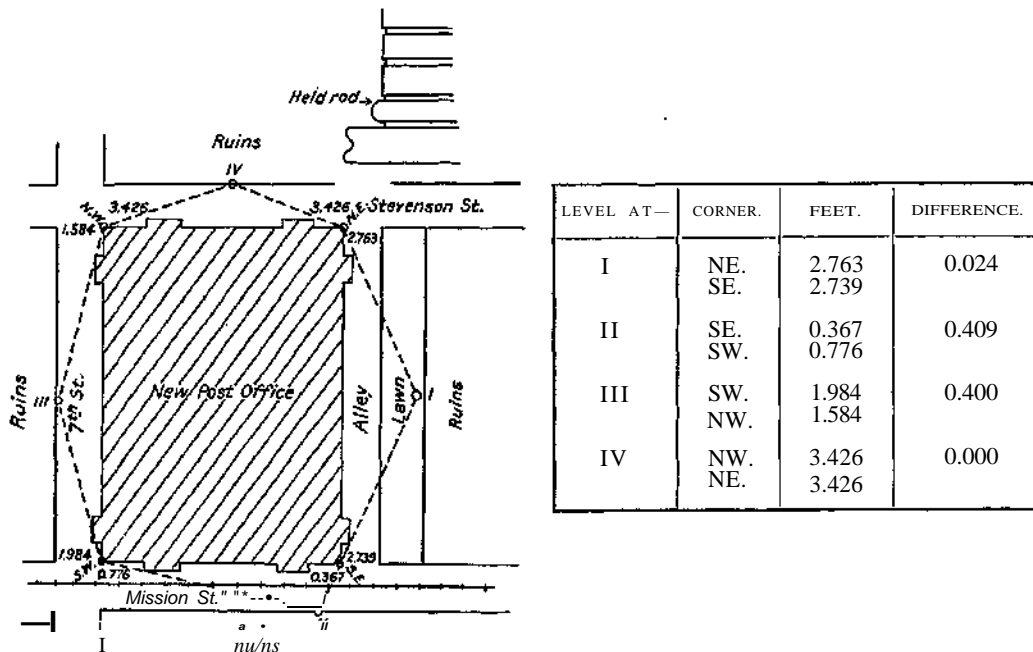

FIG. 52. — Map showing relative levels of four corners of new Post-office, San Francisco.

*Apjtraier's' Building.* — Fig. 53 shows by numbers the position of the stations occupied; and the points at the corners are indicated, as before, by their orientation.

The northwest corner is 0.909 foot = 10.908 inches above the southwest corner. The northeast corner is 0.909 foot + 0.054 = 0.963 foot = 11.556 inches above the southwest corner. The southeast corner is 0.080 foot = 0.90 inch above the southwest corner. The rod was held on top of water-table at each of the four corners, and the sights were nearly equal in length. The south side of the building is about 11.23 inches lower than the north side.

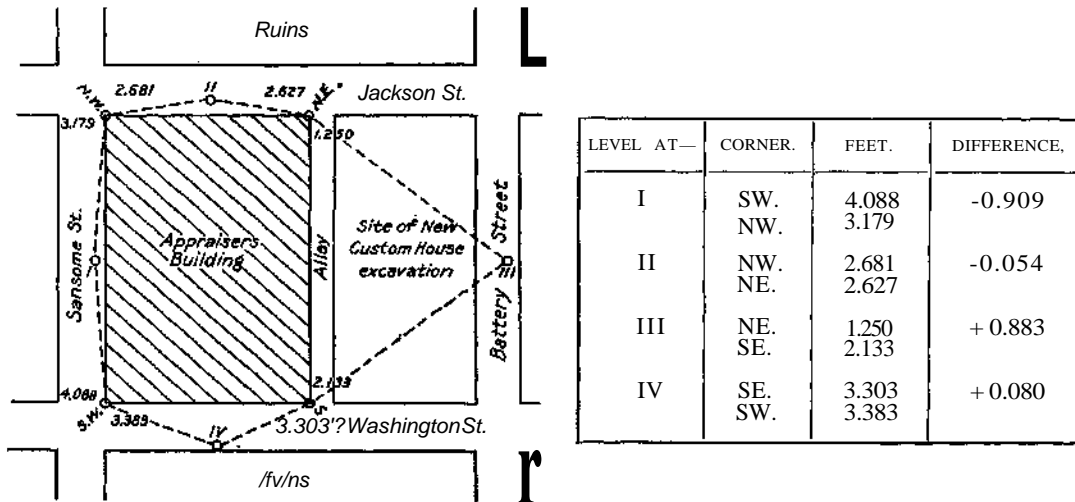

FIG. 53.—Map showing relative levels of four corners of Appraisers' Building, San Francisco.

*Mint.* — Fig. 54 shows by number, as in the former cases, the positions of the stations occupied and the points at the corners are indicated by their orientation.

The southwest corner is the lowest, being 0.498 foot= 5.976 inches (mean) below the northwest corner. The walls on the north side are badly scaled by the heat. No serious cracks were noticed in the outside. The rod was held on top of the water-table at each extreme corner of the building. Street cars constantly passing on both Mission and Fifth Streets, also heavy drays. The wind was very troublesome. Sights were nearly equal.

The deformation indicated by the above measurements can not be wholly referred to the earthquake, since it is quite probable that the structures had settled somewhat before that event. It appears, however, to be desirable to put the measurements on record for future reference.

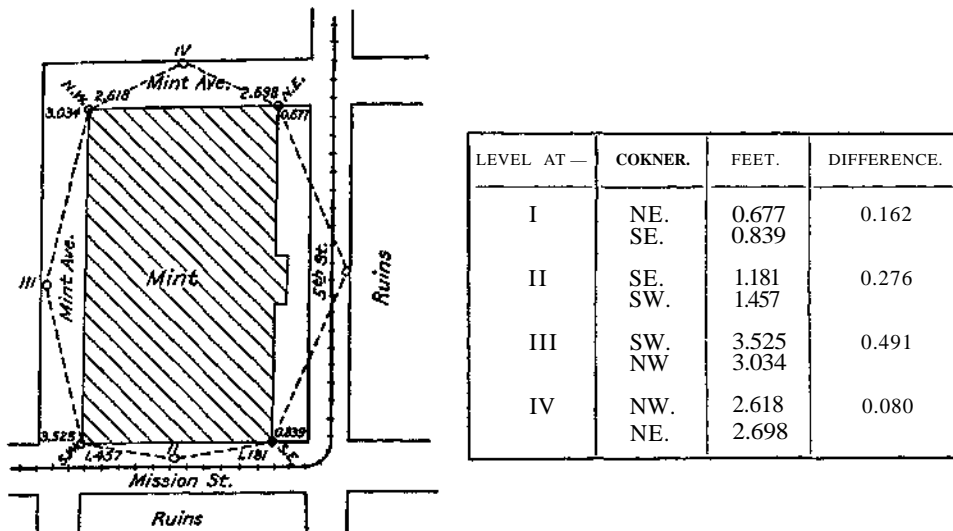

FIG. 54.—Map showing relative levels of four corners of Mint, San Francisco.

### THE SAN FRANCISCO PENINSULA.

BY ROD BRIC CR AND ALL.

The distribution of intensity in the San Francisco Peninsula, south of the city, was studied by Mr. Roderic Crandall, under the direction of Prof. J. C. Branner. The following is Mr. Crandall's report on that territory:

For a consideration of the detailed effects of the earthquake thru the area of the San Francisco Peninsula, it will be convenient to divide the country into two portions along the San Andreas fault, and to subdivide the area northeast of that line into two parts; namely, the San Mateo district, and the Merced Valley.

#### THE SAN MATEO DISTRICT.

The towns of San Carlos, Belmont, San Mateo, Burlingame, Millbrae, and San Bruno are included in the San Mateo district. These towns all lie along the railroad between San Jose and San Francisco, and are in almost a straight line; that is, parallel to and at a distance of from 2 to 4 miles from the San Andreas fault. They are all situated about the same geologically, being upon the Santa Clara Valley floor just at the east edge of the foot-hills of the Santa Cruz range.

*San Carlos.* — The railway station at San Carlos, a low 1-story stone building, was badly damaged, some of the walls being partly thrown down, and the rest of the building cracked. A large frame house near the station was shaken from its cement foundations, and the foundation itself was badly cracked.

*Belmont.* — Between San Carlos and Belmont, over four-fifths of the houses lost their chimneys, but no buildings were thrown from their foundations. At Belmont a majority of the chimneys fell. Reid's school and other buildings in the neighborhood of Belmont sustained similar damages. Reid's school is one mile nearer the fault-zone than Belmont, among the low foot-hills. Thru the hills west of Belmont no cracks nor big landslides were found, but there were small landslides along the road leading from Belmont to Crystal Springs Lake. A tall stand-pipe on the hill southwest of Belmont was unaffected, but it is a well-built structure, guyed with wire cables, and might sway without falling. Near Homestead, in the foot-hills between Belmont and San Mateo, the brick building of the Crocker Orphanage was completely ruined.

*San Mateo.* — San Mateo showed the intensity of the earthquake plainly.<sup>1</sup> Almost all brick and cement buildings were damaged and several were completely ruined. (See plates 98A, B, and 99A, B.) Many wooden structures suffered by being thrown from their foundations, while others were shifted without material damage. Nearly every brick chimney in town was shaken down, with consequent damage to the houses.

At San Mateo Point, which is on the shore of San Francisco Bay, east of the town, low frame buildings were uninjured. Tanks 5 feet deep and 4 feet wide, which were half full of water, were almost emptied by the shock, the water spilling to the southwest. The alluvial flats around the point showed some small cracks, and there was a slight sinking of the ground near the bay.

According to the man at the boat-house at San Mateo Point, the waters of the bay were quieted by the shock. Another man, who was in a boat at the time, felt the shock but not very strongly. Several fairly heavy shocks about 0 o'clock that morning were not felt at all by men on the waters of the bay. At a lumber yard, about half a mile west of the point, part of the wharf was broken, lumber piles were overturned, and a chimney foil.

<sup>1</sup> See Robert Anderson V paper on San Mateo\* and Burlingame in a later part of this report for statistical details.

*Burlingame.* — Along the line of the electric railway from San Mateo northward, many of the poles were left out of a vertical position, most of them leaning toward the northeast. At the Brewer School, in the foot-hills, about due west of San Mateo, little damage was done. A tall, well-built tank-house remained standing, tho the roof built over it, a slight, flimsy structure, was turned thru an angle of approximately  $30^\circ$ , but remained on top.

Tho there were no large brick buildings, many of the houses in the vicinity of Burlingame were badly wrecked, due to the falling of extra heavy chimneys thru the roofs. Brick walls generally fell, unless low and especially well built.

*Millbrae.* — At Millbrae there are but few buildings that could be affected by the shock, but the brick power-house of the San Mateo electric line was partly wrecked. The north and south walls fell, while the east and west ones remained standing. The latter stood because they were held by the steel trusses which spanned east and west.

In the vicinity of Millbrae and San Bruno, it was found that several of the small creeks were well filled with debris of various kinds that had been brought down by an unusual flow of water following the shock, and several days after the earthquake the streams were still carrying a small amount of water.

*San Bruno.* — Near San Bruno, where the county road crosses a small stream, there were numerous cracks in the ground from 3 to 10 inches wide, parallel to the line of the road, which is N.  $25^\circ$  W. The road at this place was built 8 feet above the mud flats, so that these cracks are accounted for by the settling of the fill. There are not many houses in the vicinity of San Bruno Station by which to judge of the intensity, but in the few houses seen the chimneys had all fallen. The race-track buildings at Tanforan, north of San Bruno, were not materially damaged, altho the buildings and bleachers are flimsy wooden structures. Plate 97c illustrates the effect of the shock upon the track of the electric railway on the marsh west of San Bruno.

#### THE MERCED VALLEY DISTRICT.

The Merced Valley district includes not only the valley proper, but also the area covered by the main body of the Merced sediments, from the San Andreas fault-line, east by Baden to South San Francisco and along the southwest face of the San Bruno Mountain, and by the cemeteries to the Life Saving Station on the coast north of Lake Merced.

*Baden.* — Baden, at the south end of the Merced Valley, consists of only a few houses, none of which shows marked effects of the earthquake. The track of the electric tramway line, just south of Baden, shows evidence of intense disturbance. (See Plate 97D.) The roadbed which was built up nearly all the way here was cracked parallel to the rails. One crack varied from 2 inches to a foot in width, and extended about 1,000 feet along the filled-in roadbed. For this distance the double tracks were twisted back and forth in a zig-zag fashion, and up and down to some extent. One rail was bent 2 feet horizontally and 10 inches vertically. Not a single rail in this 1,000 feet remained straight or in place, but in no case were the rails detached from the ties. Most of the poles supporting the electric wires were thrown out of line. The ties were shoved back and forth and from side to side, leaving clean, bare places where they had slid about.

The tracks of the Southern Pacific Railway line, which are parallel to the electric road in the vicinity of Baden Station, were slightly disturbed but not so badly that trains could not run over them. The Southern Pacific roadbed is much better ballasted than the electric line, because it is older and has become more firmly packed, which is the reason that it was not disturbed like that of the electric line. This disturbed portion of the electric line continues about 200 feet north of a road by the Baden Station, until a cut is reached where filling up was no longer necessary. The cracks were thus confined to the filled ground.

Just east of the station at Baden, where a creek crosses the county road, there were cracks in the filled soil, and there was also evidence that in this low ground the creek had flooded a distance of 100 feet on both sides of its usual course. At the time of the first visit, about 3 days after the shock, there was more water in the creek than there had been the previous week. At this same place, a steel water-main, supported on trestle-work, was wrenched so that it leaked badly.

At Big Frawley Canyon a trestle carrying a 30-inch water-main was demolished. (See plate 100A.)

The electric-car line that runs to South San Francisco turns a right angle at Baden, from northwest to northeast. The rails northwest and those northeast of the turn were both badly bent. On the northeast branch the rails were bent into a U-shape, the base of the U being to the northwest with a side thrust of about 2.5 feet. The rails on the northwest end of the line were bent into a V, with the base of the V pointing northeast, the lateral displacement being about 1.5 feet. These are about 60-lb. rails, and at the V-shaped bend mentioned the rails were broken in three places.

*South San Francisco.* — 1.5 miles east of Baden, at South San Francisco, the intensity was considerably lower than at the previously mentioned places. Many chimneys fell, but no badly wrecked houses were seen. At this place the corner fell from a new brick building, under process of construction, and some of the other large brick buildings were slightly cracked. The damage at South San Francisco was not large, taken as a whole. (See plate 97B.)

A little more than a mile east of the town, there are several tall brick stacks, none of which fell. Some were entirely uninjured and others slightly cracked, but only one, so far as known, was badly enough damaged to require rebuilding. The brick structures and stacks at the packing house did not suffer materially.

Some of these buildings are almost on the San Bruno fault-line, and none of them are far from it, so that if there had been any movement along that line, these would certainly have suffered more.

South San Francisco and the meat packers' establishments are on a different geological foundation from the towns previously mentioned. These places rest almost directly upon the old Franciscan rocks, with only a thin layer of sand on top of them in places. This makes a much firmer foundation than is found at the other places, which are situated upon a considerable thickness of sand or gravel.

The buckling of the tracks of the South San Francisco car line between the town and San Bruno Point, where the chimneys mentioned are located, is significant of the contrast in the intensity of the shock at the two places. The rails are bent and broken in a number of places, where the track crosses the marsh between the two places. The difference of intensity is striking when it is taken into consideration how close they are together.

From South San Francisco to San Bruno, there is a line of big steel water-mains, supported on a trestle frame, where it crosses the marsh. This line did not break, but was bent and twisted into S-shaped figures.

North of San Bruno Point, at the Southern Pacific tunnel along the bay shore cut-off, no damage was done, except for the sliding and settling of the debris in the newly filled area.

*The cemeteries.* — The San Bruno fault-line was followed all the way from South San Francisco to the cemeteries. There was absolutely nothing to indicate any movement along that line at the time of the earthquake.

The cemeteries between Baden and Colma suffered very severely from the shock. It was estimated that in Holy Cross Cemetery (plate 96B) over 75 per cent of all the monuments were either thrown down or twisted on their bases. Plate 97A shows a typical



case of a monument overthrown. In a few cases monuments were snapped off. In one instance a single piece about 3 inches thick was broken off by the shock. The upper part of the slab is in two pieces, tho the second break may have been made when the slab fell. The stone chapels at several cemeteries were badly shaken and partially wrecked.

There is one monument in Holy Cross Cemetery that was composed of several pieces, the top piece being the figure of an angel. Underneath this angel was a small thin piece of stone beveled to meet the base of the figure, and below that was a block of about 20 inches square and 12 inches thick. It was observed that the washer and the square block were inverted in their positions. It is stated that this displacement and inversion of these blocks was effected by the earthquake. If so, there must have been enough upward motion to throw this block and washer high enough to turn completely over.

There was no consistency apparent in the direction in which monuments fell; they seem to have fallen in every direction.

The other cemeteries all suffered about the same, but the percentage of fallen monuments was not nearly so high in the others as it was in the Holy Cross Cemetery. The reason for this difference in the number of monuments overthrown is not apparent; the soil of all these cemeteries is practically the same. A possible reason is that the difference in effects is due to a difference in the depth of the sand upon the underlying rock floor, and that there was a greater depth of sand underneath the Holy Cross Cemetery. There is no proof of this, however.

Plate 95A and B illustrates the wreck of buildings at the Woodlawn and Hills of Eternity Cemeteries.

On top of the gate posts at Holy Cross, there were two large ornamental stone balls. These were fastened to the posts by steel rods projecting up into them; these rods, however, did not hold them in place and the balls were both thrown down. West of the gates the stone railroad station was badly wrecked, fully one-third of it being shaken down. Between the depot and the gates small 1-inch water-pipes, running in a northeast-southwest direction, were bowed upward and forced out of the ground. In relaying the pipes, they were not set more than 1 foot deep, from which it is inferred that they were probably not more than 1 foot deep before the earthquake.

In front of the Holy Cross railway station (plate 96A) the tracks of the main line of the Southern Pacific were slightly bent, but the lighter rails of a side track near by were much more disturbed. Around the station the ground had settled and there were a number of cracks, from 4 to 6 inches wide, but these were probably due to the fact that this ground had been filled in to get the required grade for tracks and the station.

*Landslides.* — North of Holy Cross Station, by a little lake west of the cemetery, there was a large landslide along the roadbed of the Southern Pacific Railway. For about 300 feet the bed caved and in one place the west track was left suspended in the air. West of the railroad there were large cracks in the newly filled grounds of the Woodlawn Cemetery.

One hundred feet west of the Southern Pacific Railroad track is the electric line of the United Railroads between San Mateo and San Francisco. This roadbed was also filled in considerably for the required grade, and was not as well settled as the Southern Pacific tracks, so it suffered more severely. West of the Holy Cross Cemetery, the rails were distorted and pulled apart 3 or 4 inches at the joints, due mainly to the dropping of the roadbed. Poles were out of true, but no wires were seen broken from tension or the swaying of the poles.

Northeast of Mount Olivet Cemetery there was an earth-flow in the sandy soil at the base of the San Bruno Mountains. The angle at which the materials slid was hardly more than 10 degrees. The sand and water forming this slide came out of a hole several hundred feet long and 150 feet wide, flowed down the hill several hundred yards toward

the cemetery, carried away a pile of lumber, and knocked the power-house from its foundations. The front of the mud-flow piled up in a bank when it reached the nearly level ground, and dammed up the mass behind it. The earth was harder several weeks later than it must have been at the time of the flow, but it was still slushy and there was still a little water flowing along the path of the earth-flow, coming from a small spring where the slide originated.

On the west bank of a creek, near and parallel to the line of the railroad southwest of Holy Cross Cemetery, there was a crack several hundred feet long. This was along the bank near the creek bed and was an incipient landslide.

On the east edge of the hills west of the Chinese Cemetery and 9-mile house, a line of cracks extends for a distance of about 1,000 yards. These cracks are more than a foot wide in places, and there is an apparent downthrow on the northeast; in one place there is a long line of crushed earth, such as occurs along the main fault-line. Inspection showed that these cracks were caused by a slight landslide. The line of crumbled earth was due to the earth above it on the hillside sliding slightly, and the crumbling represented a line of buckling of the crust.

These cracks are upon the top of a hill, at an elevation of about 400 feet; their general direction is about N. 40° W., and parallel to the San Andreas fault, and the line of hills here has the same general trend.

A line along the east edge of the hills, then, would naturally have the same trend as that of the main fault. A continuation of these cracks would go to the ocean thru Wood's Gulch, which is along the line of a small fault; but no evidence could be found showing any visible movement at the time of the late earthquake. There were several large landslides on both the southwest and northeast sides of the gulch, and at the ocean the amount of dirt that had fallen was very large. These things show a high earthquake intensity, but there is no evidence of other movement.

*The coast north of Mussel Rock.* — Along the coast from Mussel Rock to Lake Merced the section known as Seven Mile Beach presented steep cliffs from 1 to 700 feet in height. These cliffs are composed of the beds of the Merced series, which are soft clay and sandstones only partially consolidated. Along the face of these cliffs the Ocean Shore Railway had started a grade at an elevation of about 300 feet above tide level. Along this bluff a large amount of earth slid down the slopes at the time of the shock. This caving of the banks was due to the nature of the soil, the proximity to the fault-zone, and the disturbance of natural slopes due to the railroad terrace near the top.

In places this slope toward the ocean was brought about to the angle of the repose of this material and the roadbed was entirely destroyed for a distance of 3 miles.

On April 25, the writer was on the edge of the cliffs near Wood's Gulch. About 3 P.M. of that day there was a shock with an intensity estimated to be between VI and VII. At that time the cliffs shook like so much gelatine, and it was necessary to hold on to prevent falling. On the north side of the canyon, hundreds of tons of earth fell even with this light shock.

Along the top of the cliffs large cracks were formed to a distance of several hundred feet from the edge. Many of these cracks were a foot or even as much as 3 feet in width, and small scarps were often present, 4 or 5 feet high and 20 or 30 yards long. The general tendency was for everything to slide into the ocean, but this was not always true. Miniature scarps of more than 6 feet were seen with a downthrow upon the northeast or inland side. The Merced beds, as a whole, were badly shaken, and broke up all along the coast section. Near Mussel Rock part of the roadbed slid for about 500 feet and on the hillside above the road there was a long crack which was the beginning of a slide that might have taken a large part of the hill. The direction of this crack was about N. 45° W., which is more toward the north than the fault-line at this particular place.



A. Woodlawn Cemetery, south of San Francisco. A. O. L.



B. Hills of Eternity Cemetery, south of San Francisco. All firm gables thrown out. Parapets thrown in on roof. A. C. L.

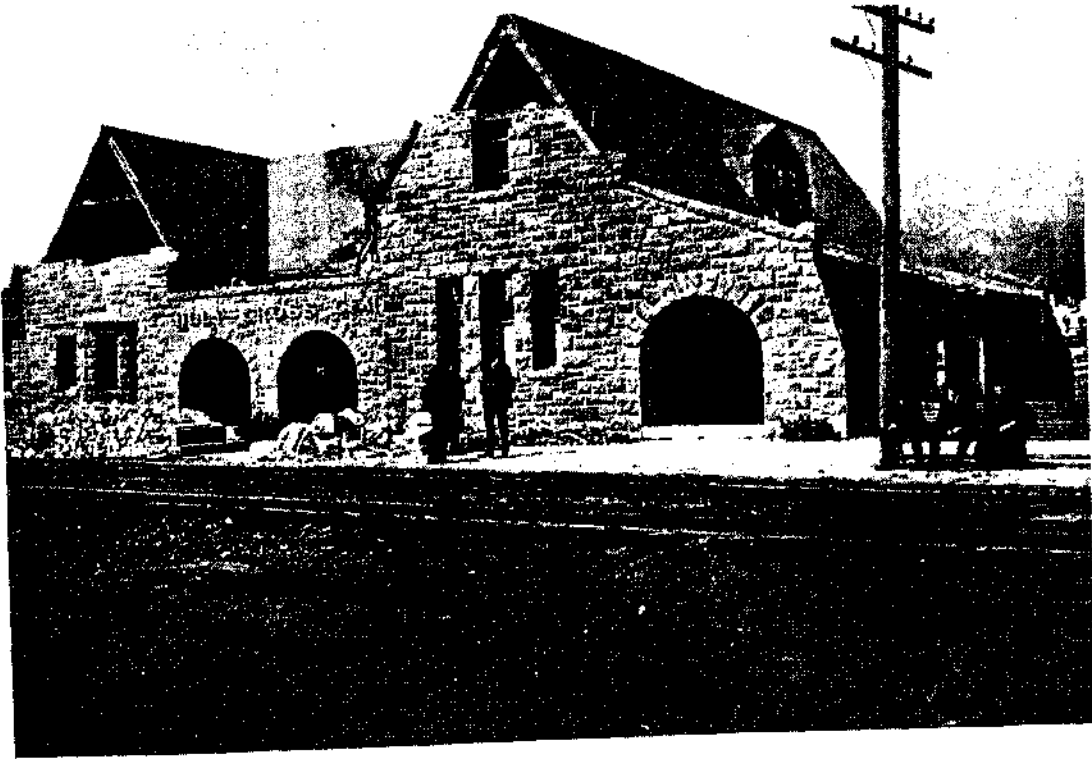

A. HolyOroas OametyxStation.BOUtaofSanFranoiaco. BuUding on made ground. A. 0.1.



T< HolyCxo^Camatery.mt^fSasFraBd^ A. 0.1.

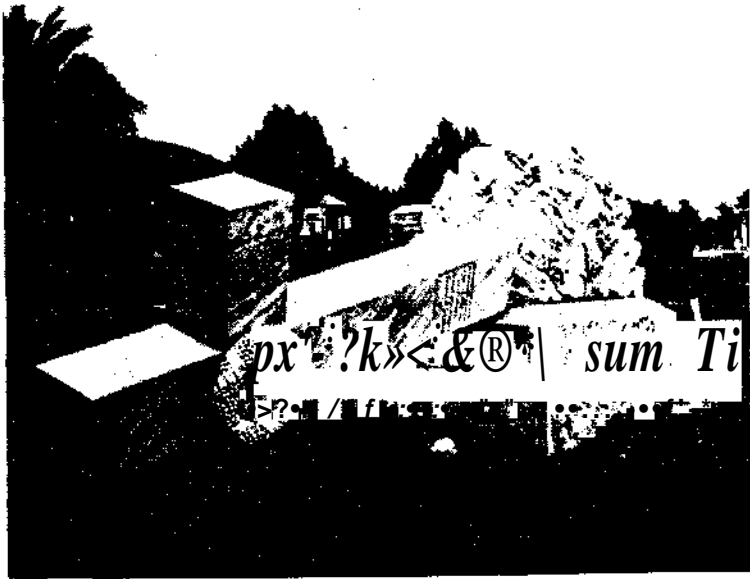

A. Overtbrowm monnment, Holy Cross Cemetary. E. B. M.

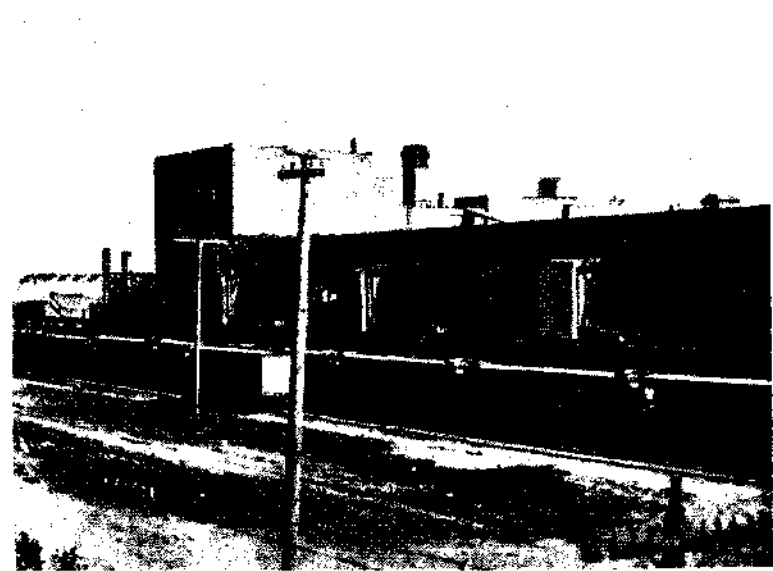

Briok bnilding and high olimney left standing. South San Franaisco. E. B. M>

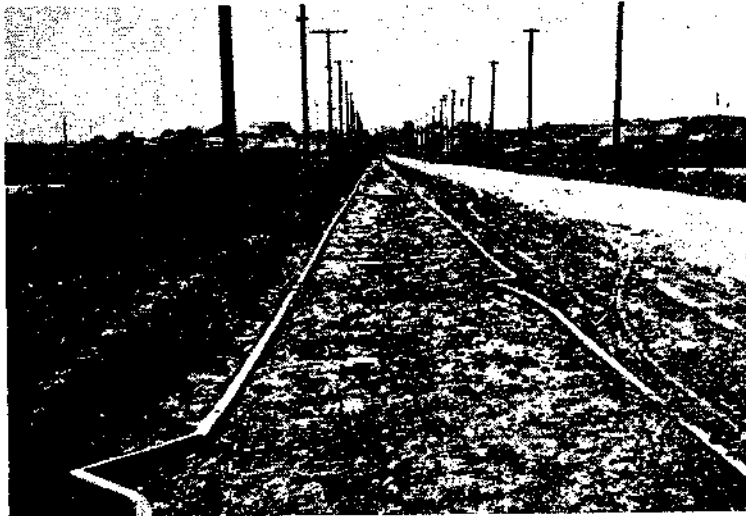

0. Eoadbed and rails of electric railway on marsh west of San Bruno. E. B. M.



D. Eoadbed and rails of electric railway between Baden and San Bruno. E. B. M.



A. Wreck of 1-story brick railway warehouse, Beaufort, N. C. Per J. O. B.



B. Brick stable, Sacramento, Calif. Upper story was thrown out and roof dropt onto story. Per J. C. B.

*Lake Merced.* — About 6 miles north of Mussel Rock, where the Merced beds disappear under seolian sands, the disturbance seems to have been quite violent. An old railroad trestle, that crosses the northern end of Lake Merced in the narrowest place, was badly wrecked. This bridge was broken in two places, and the intermediate piece was out of line with both ends. The direction of the offsets was very nearly due north and south. At one break the west piece was shoved 12 or 14 feet past the other section. The west end of the intermediate piece failed to join the section at the west bank by 6 or 7 feet. The west section that remained with the bank was from 4 to 5 feet lower vertically than the intermediate piece. The trestle was old, built of heavy timbers on a sharp curve, and not in use, which will in part account for its destruction. The swaying of this bridge destroyed a section of it 50 to 60 feet long. On the hillside where this trestle reaches the west bank of the lake, cracks parallel to the shore line suggest the cause of the destruction of the bridge. The displacements here are larger than any along the main fault-line, and it is apparently entirely local, due to the slipping and settling of the west bank of the lake.

Upon following around the north end of the lake to the road that runs to the Life Saving Station, a line of terra-cotta pipe, about 8 inches in diameter, was found. There was no large displacement found in this pipe, altho it had been cracked at many points. There is nothing in these phenomena to show that there was a fault thru the Merced Valley.

Just south of the bridge across Lake Merced, a sand-bar was forced up out of the lake, from water that was previously 6 or 8 feet deep. This bar is parallel to the west bank of the lake, and has a direction almost due north and south. This was probably caused by the same thing that wrecked the bridge; that is, the displacement and settling of the west bank of the lake at the time of the earthquake.

#### THE AREA SOUTHWEST OF THE SAN ANDREAS FAULT.

*Difference of apparent intensity on the two sides of the fault.* — On passing from the beds of the Merced series on the northeast to the southwest side of the fault, there is a marked difference between the distribution of small cracks and little earthslides. On the northeast side, in the Merced beds, these cracks and landslides are common, but on the southwest side they are entirely absent. This can hardly be taken to show that there was any difference in intensity on the two sides of the fault; it is probably the result of the difference in the character and stability of the rocks. At other places north of the fault, but southeast of the Merced beds, this difference has not been noticed, probably because in that part of the area the rocks are nearly all Franciscan.

On the south side of the San Andreas fault there are no towns affording an opportunity for judging the intensity of the shock. The gradation must of necessity be based upon something else. Landslides occur both near the fault-zone and at a distance from it, under somewhat similar geologic and topographic conditions. It seems to be a fair assumption that a landslide is indicative of a high intensity.

*Laguna Salada Valley.* — In the valley of Laguna Salada, the Ocean Shore Railroad had a temporary trestle erected for making a fill in the valley up to required grade. This trestle was twisted and thrown out of line, and the earth sank along the newly filled roadbed. Similar things happened to newly filled roadbeds along the west edge of the Santa Clara Valley, near Baden and San Bruno.

Along the base of the cliffs south of Laguna Salada, there were several small slides, some from the face of the hills and others in the newly graded roadbed. There were many small cracks along the tops of the cliff, parallel to its edge, showing that the face of the bluff was shattered, and that more earth might slide. One big rock pinnacle, which had been left above the roadbed as a landmark, and which had seemed a little dangerous before, was shaken down.

*Calera Valley.* — In Calera Valley the shock was severely felt by people in some small temporary shacks: South of this place, in the San Pedro Valley, two old wooden houses showed no structural damage, and only one of two brick chimneys was thrown down.

*San Pedro Point.* — From San Pedro Point southward for about 1.5 miles, the cliffs rise to heights of from 400 to 800 feet. The railway company had cut a bench for its roadbed several hundred feet above the ocean. This roadbed, being largely in solid rock, was for the most part not much injured; but in some places it was obliterated by rock slides that came from above.

Just north of the point known as Devil's Slide, there was a landslide of the whole face of the west end of Montara Mountain. It started at about 800 feet above the sea, and swept down carrying many hundred feet of roadbed along with it. The material that slid was sandstone and granite, but it seemed to be much weathered and softened in places, so that it was loose ground.

South from the Devil's Slide to the first small coast valley, there were landslides along the cliffs. The rock in this vicinity is massive granite, but the landslides showed that the rock had disintegrated for a considerable distance below the surface and the slides were in this decomposed rock. Wherever the railway bed was filled or built out with this material, there was more or less sliding and settling, caused by the earthquake.

*Montara Point.* — The old, low brick structure at Montara Point did not show any effects of the shock, but there was some damage to a wooden tank-house. One of the tanks, which was previously known to be old and rotten, collapsed entirely. In the yard of the keeper is a concrete water cistern which holds over 6,000 gallons, and which is set flush with the ground and protected with an iron cover that two men can hardly lift. At the time of the shock this tank was almost full and had the cover on. The violence of the shock was sufficient to throw this cover 10 or 15 feet, and spill about 3,000 gallons of the water in all directions.

The observations of the light-house keeper are considerably at variance with what some people have said regarding the behavior of the ocean at the time of the earthquake. Many persons told of waves that had rolled high up on the cliffs. The keeper reports that during the actual period of shaking the ocean was smooth, without even the customary motion. After the shock had ceased, it was perhaps half a minute before the calm was broken and the regular swell began. He reports that he was upon his feet at the time of the shock, and altho used to being on shipboard, could stand only with great difficulty.

This testimony as to the appearance of the water is almost the same as that of the light-house keeper at San Mateo Point. There was no evidence anywhere along the coast to show that the water rose above tide-level.

On the southwest face of Montara Mountain, nearly all of which is visible from the road, no landslides of any size were observed.

*Landslides.* — South of Montara Point, in the low foot-hills north of Half Moon Bay, there were two large low-angle landslides or earth-flows. One of these landslides was on the low foot-hills facing the ocean; the other on the northeast bank of Frenchman's Creek, several miles northeast of Half Moon Bay.<sup>1</sup>

From Half Moon Bay to San Mateo, there were several large slides of different character from those already mentioned. These resulted from the slipping of large masses of rock, many of the fragments in one of the slides being over 20 feet in diameter. (See plates 124c and 126B.)

On the south face of Scarper Peak, and on the southwest face of Ox Hill, there were several landslides both large and small. No photographs of the larger slides are available.

About 4 miles east of Half Moon Bay, just off the south edge of the San Mateo sheet, there was another large earth-slide similar to the two already mentioned.

---

<sup>1</sup> These are described by Mr. R. Andemon in the section dealing with Earth-flows.



*Pilarcitos Canyon.* — In Pilarcitos Canyon, the stone dam of the artificial lake was uninjured and the flume down the canyon sprung only a few leaks. Mr. Ebright's house, at the lower end of the lake, lost two out of three chimneys by the shock. The spring water at this place, which is used for house supply, is said to have been milky-white during the day of the earthquake. This canyon is made by one of the large faults mentioned in the first part of the paper. If there had been any movement along this fault, it would have been shown at the dam which crosses the canyon at a right angle to the fault-line.

*Cahill's Ridge.* — This range of hills forms the northeast side of Pilarcitos Canyon, and is the second ridge southwest of Crystal Springs Lake, with the same general northwest-southeast trend. On the top of this ridge, a small house lost one of two chimneys, and things inside were shaken around. A table is said to have tilted enough for dishes to slide off.

Just southeast of the house is a depression in the ridge, across which furrows and cracks formed similar to those along the main fault-line, but not extending more than several hundred feet. These cracks do not seem to have been landslide cracks, for they are on top of the ridge and on a flat piece of ground.

Another peculiar phenomenon was observed upon Cahill's Ridge, less than 1 mile northwest of the cracks mentioned. In an area of limestone, a small patch some 30 feet in diameter was torn up as tho it had been plowed and harrowed, and no large pieces of sod were left intact. Around this in various places were cracks of a few inches in width, with one or two over a foot wide. There was a slight downthrow on the uphill side to be noticed in some of these cracks, which eliminated the possibility that they were cracks preparatory to landsliding.

*Sawyer's Ridge.* — On Sawyer's Ridge, about 9 miles north of the region described on Cahill's Ridge, there were cracks several hundred feet long almost at the top of the ridge. These were parallel to the line of the main fault, which is a mile to the east, and there was a marked downthrow of from 2 to 3 inches on the southwest side, which in this case was the uphill side. If the downthrow were on the downhill side, then it could be possible that these were landslide cracks. The exact cause or mode of the formation of these cracks, or the breaking of the ground on Cahill's Ridge, is not clear.

In the canyon between Sawyer's Ridge and Sweeney's Ridge, a 2-story wooden house did not suffer much, and out of 4 chimneys only 2 were cracked. One of those that remained standing was a tall top-heavy chimney of brick; the other was only a tin pipe.

At Byrne's store, on the Half Moon Bay road, half a mile west of Crystal Springs Lake, it was reported by the keeper that the water from their spring, on the day of the shock, was muddy and was not tasted. On the second day after the earthquake, it had a very salty taste, but on the third day was normal. A house on the northwest side of Half Moon Bay road, 2,000 feet southwest of the dam, was thrown from its foundations, while some 200 feet northwest of this house there was a slide in the canyon.

#### CONCLUSIONS.

There was no marked difference of intensity on the two sides of San Andreas fault-line.

There was a decrease of intensity on both sides of the fault-line, as one goes away from it.

The distribution of intensity bears no evident relation to the minor faults or structure of this area.

It is evident that the intensity varies with the geology, or with the areal distribution of rocks and soils.

The areas that suffered most severely were those upon filled ground.

Areas upon marshy ground showed destructive effects similar to artificial filled land.

Next in intensity to areas of filled land are those upon incoherent sands. The damage in sandy areas was due partly to the shaking of sand like jelly and partly to settling and sliding.

Areas that suffered least were upon rock of some kind in place.

Towns along the west edge of the Santa Clara Valley, at equal distances from the fault-line and upon similar geological formation, showed the same intensity.

The waters of the bay and of the ocean were quieted by the shock, and there was no perceptible tidal wave following the movement.

The shock was not felt as strongly upon the waters of the bay as upon the land near by.

There was an unusual flow of water in the creeks draining into the bay near Baden and San Bruno, directly after the shock.

The destruction of buildings and the disturbance of railway roadbeds and rails was much more violent thruout the area covered by the incoherent Merced beds than on the older hard rock in the adjoining areas.

There was a large amount of damage done in the cemeteries, which are on seolian sands.

A large number of the monuments fell at the cemeteries, but there was no consistency in the direction of falling to show the direction of motion.

Motion in more than one direction was suggested by monuments twisted upon their bases. Vertical motion was shown in one monument which had the upper portion turned upside down.

#### NOTES BY OTHER OBSERVERS.

*San Mateo, San Mateo County* (Mr. Maxwell). — At the time of the shock Mr. Maxwell had led a horse out of the barn to give him water. He first heard a heavy rumble, which he took for thunder, coming from the northwest. This was followed by a wavy motion of the ground. The earth rose and fell like the swell of the sea, the waves being about 3 feet high. A water-tank about 30 feet high tipped over to the southeast so as to throw water out and allow him to look into the top of the tank, he being 75 or 80 feet distant. The tank swayed back to its place without falling. The two wave motions were followed by a severe shock, as if the waves from the northwest and southeast met suddenly under him. Both he and his horse were thrown off their feet. The horse attempted to run, but could not on account of the violent motion of the earth.

*Redwood* (E. C. Jones). — The mains of the gas plant are all of steel and suffered no damage. The gas-generating apparatus was moved several inches on its foundation, and all cast-iron connections were more or less damaged. The buildings, being of frame and corrugated iron, were not seriously damaged. A 20,000-foot gas-holder in a redwood tank above ground was completely demolished by the earthquake. The shock seems to have been particularly severe at Redwood City, and the boiler settings at this station were badly damaged, while at San Mateo, 9 miles distant, the settings were uninjured.

# THE CALIFORNIA EARTHQUAKE OF APRIL 18, 1906

---

## REPORT OF THE STATE EARTHQUAKE INVESTIGATION COMMISSION

---

IN TWO VOLUMES AND ATLAS

---

VOLUME I, PART II



WASHINGTON, D. C.  
PUBLISHED BY THE GARNEGIK INSTITUTION OF WASHINGTON  
1008

CARNEGIE INSTITUTION OF WASHINGTON

PUBLICATION NO. 87, VOLUME I, PART II

Printed by  
J. S. Goring O. — Lithwick A Smith Co.  
New Haven, Conn., U. S. A.

## PART TWO.

---

### ISOSEISMALS: DISTRIBUTION (W APPARENT INTENSITY-CONTINUED).

AREA OF THE SANTA CRUZ QUADRANGLE OF THE U. S. GEOLOGICAL SURVEY.

The distribution of intensity in the area of the Santa Cruz Quadrangle was studied by students of Stanford University, under direction of Prof. J. C. Branner. The contributors to data embodied in this part of the report are Messrs. R. V. Anderson, H. W. Bell, B. Bryan, R. E. Collom, R. Crandall, P. Edwards, H. P. Gage, F. Lane, R. Moran, R. L. Motz, A. F. Rogers, S. Taber, A. F. Taggart, F. W. Turner, and G. A. Waring.

*Stanford University* (J. C. Branner). —Referring to the group of dwellings southeast of the University quadrangle, there were 61 residences on the campus of Stanford University at the time of the earthquake. Out of 140 chimneys on these buildings, 104 were thrown down, or 74 per cent. The plaster was generally badly broken on the first floors of these buildings, and less injured tho generally more or less cracked in the second-floor rooms. At No. 13 Alvarado Row, first floor, several pictures 18 inches across, and hanging by cords 4 feet long, were swung so far that they were left with their faces to the wall. On the corner of Saivatierra and Aguello Streets, a frame building occupied by the Chi Psi Fraternity was so badly wrecked that it had to be abandoned. The injury done this building was due to its having stood upon posts 4 feet high and nut well braced; the swaying of the building threw it off these supports.

President Jordan's residence, west of the quadrangle, had 3 brick chimneys, all of which were thrown down; the plaster WLS so badly injured that the first floor, the ceilings, and part of the second floor had to be replastered. This building rested upon a brick foundation about 4 feet high.

The Stanford residence, a mile north of the quadrangle;, was so badly wrecked that it has since been torn down. The original building was of brick, and wooden additions had been built on the northwest and southeast sides of the brick portion. The additions stood upon wooden uprights 4 feet in length. The southeastern wooden addition was thrown from its supports and fell away from the older brick portion. The brick portion of the structure was badly shattered. In the grounds and parks about the residence there were many marble and bronze statues from 4.5 to 5 feet high, standing on pedestals from 2 to 4 feet high. These were all thrown down, except a few that were very securely bolted to heavy pedestals. There was no uniformity in the directions in which they fell.

Between the Stanford residence and the museum, a large 2-story brick winery had the 4 gable ends thrown down. The northwest gable fell into the building, the southeast gable fell outward, while the gables on the northeast and southwest sides fell outward.

Mr. Charles G. Lathrop's residence is not on the valley floor, like the other buildings in the immediate vicinity of the University, but stands on a hill of sandstone nearly 300 feet above the level of the bay. Out of the 4 brick chimneys on his house 2 were thrown down; 2 water-tanks 53 feet high (10-foot tanks on 43-foot supports) were not injured, but about two-thirds of the water was thrown from them.

Professor Durand's house, south of the quadrangle, is on a hill 160 feet above the bay mid stands on the upturned edges of gravel beds that underlie the Santa Clara Valley. Of 3 chimneys, 2 were thrown down, and the plaster was cracked on the ground floor.

Of the University buildings proper, pome were unhurt while others were completely wrecked. (See plate 1()2n.) They all stitnd upon tin; loon\* gravelly louut of the Santa

Clara Valley floor. As a rule, the older the buildings were the better they withstood the shock. Much damage was done by the throwing down of stone chimneys. The 150-foot stone chimney of the power plant was thrown down, crushing part of the boiler house and killing a fireman. The double-flued 60-foot chimney of the assay laboratory fell. The large stone chimneys of the dormitories were broken off at the roof edges and fell into the buildings. At Encina Hall, the men's dormitory, one chimney fell thru the roof and carried down a tier of rooms into the basement, killing one student. The south ends of the wings of Encina Hall were so badly cracked that they had to be entirely rebuilt. It was found that the injury done to the ends of the wings was due to the relation of these particular walls to the roof beams. Excepting the cracking of plaster, Encina Hall was not otherwise injured, tho it is a 4-story building, with basement and attic.

The chimneys also fell from Roble Hall, the women's dormitory, and did some damage to the roof and upper floors; but the building, which is of concrete, was otherwise unhurt.

The Chemistry building had 32 tile-lined stone ventilating chimneys projecting 12 to 16 feet above the roof, besides 2 ordinary stone chimneys; these were all thrown down.

The stone tower of the church was shaken to pieces, and in falling destroyed the parts of the roof immediately around the tower. The north gable end of the church was thrown outward into the quadrangle. (Plate 103B.)

The top of the memorial arch was broken off down to the upper part of the frieze, and in falling it wrecked adjacent portions of the arcades to the east and west. (Plate 103A.) The parts of the arch left standing were cracked. The 2 smaller arches at the east and west ends of the inner quadrangle were slightly cracked near the top, but they were not seriously damaged.

Besides the damages to the church and the memorial arch, the most serious injury to the quadrangle group of buildings was done to the larger structures. The 1-story buildings, especially those that had been standing for several years, were not damaged beyond the occasional cracking of plaster; and even in these cases the injury was found to be directly related to the method of supporting the roofs upon the walls. The statues of the front fayade were dislodged and one was thrown down. (Plate 100B.)

The 1-story buildings in the outer quadrangle had all been lately put up, and these were somewhat cracked, tho none of them was seriously hurt. The cracks were generally about the ends of the buildings and along the tops of the walls where the roof timbers rested upon them. The higher buildings of the outer quadrangle were more seriously damaged, especially those situated on the cornel's. These buildings are all three stories and basement. The towers on the inside corners of these buildings were all more or less broken and require rebuilding. The Civil Engineering building — three stories and basement — at the southeast corner of the outer quadrangle had its outer walls badly cracked, especially on the north face, and about the tower at its northwest corner. Inside the plaster was injured more or less all thru the building.

The Geology building, at the southwest corner of the outer quadrangle, was the last building of this group to be put up. It was a 3-story structure, and had barely been finished; but it was not yet occupied when the earthquake occurred. Sections of the walls were thrown down from every face of the building. These sections extended from the caves down to the second floor. The tower at the northeast corner was badly cracked and part of it fell. The plaster was broken on all the vertical walls, both on the outside walls and on the partitions, showing that there was much internal wrenching of the building. The walls of this building will all have to come down and be rebuilt from the foundation. (Plate 102A.)

The inner arcades of the quadrangle were not much affected. At one place on the south side of the memorial court, where the arcades are not directly connected with any other building, they were so violently swayed that they seem to have come near falling. They were found to be 7.75 inches out of alincmnt after the earthquake, and the tops of the bases of the supporting stone columns were chipped off. (Plate 105B.)



L. Wreck of 2-story trick building, San Mateo. Per J. O. B.



B. Wreck of 2-story brick buildbg, San Mateo. Per J. C. B.



A. Trestle carrying a 30-inch water pipe across Frawley Q-nloh demolished by shook. E. L. H.



B. Statue of Agassiz thrown from its niche above arches, Stanford University. Per J. O. B.





A. Destmouitiou of arcade at Sacred Heart Convent, Menlo Park. E. O.



B. Gateway of Campus, Stanford University. Per J. O. B.

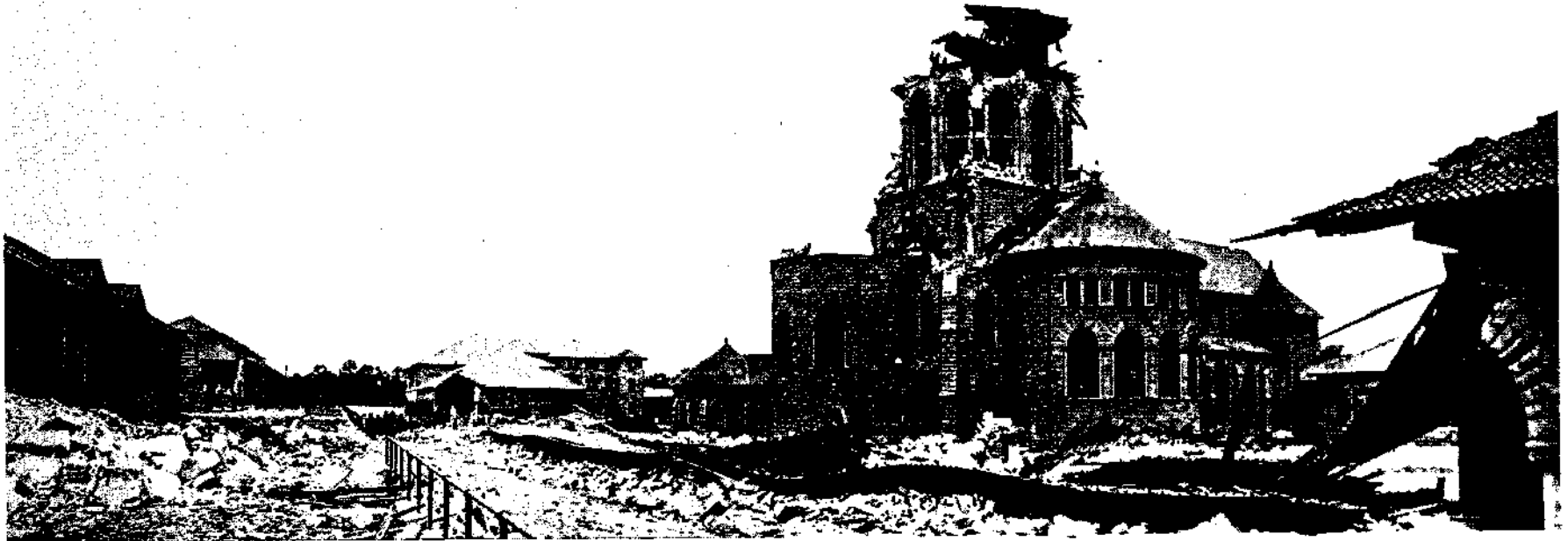
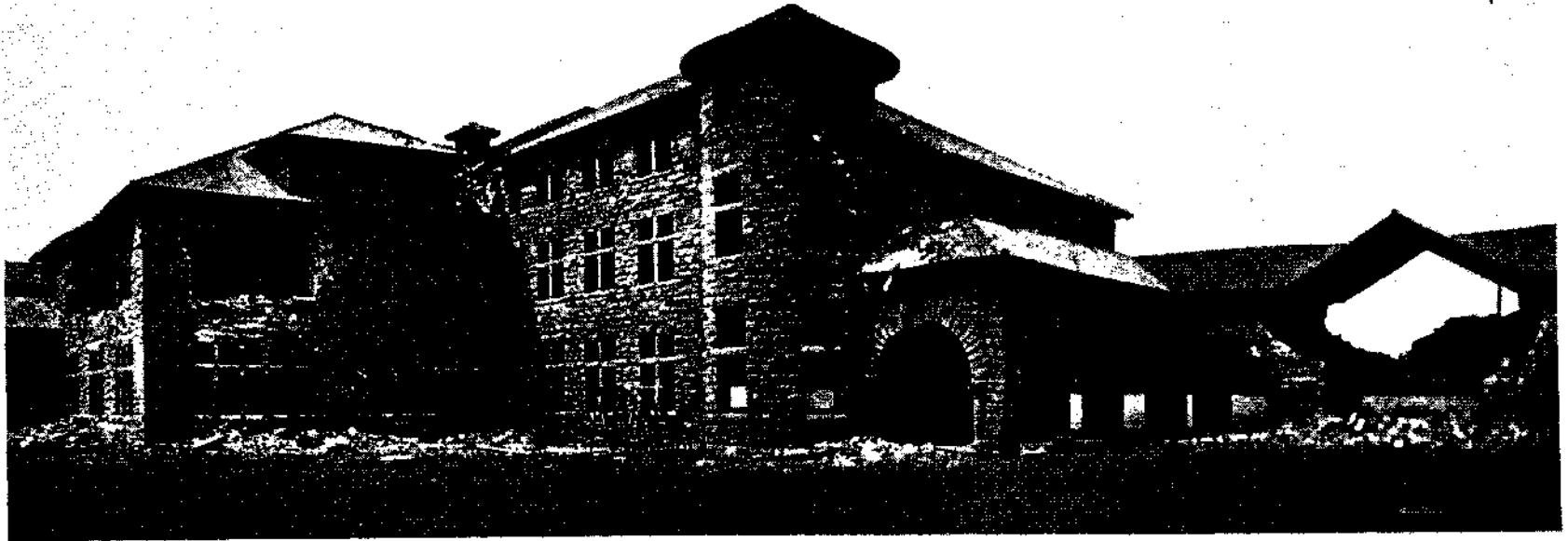

A. Geology Building, Stanford University. Per J. O. B.

B. Panorama of destruction, Stanford University. Memorial chapel in middle right. Per J. O. B.

The arcade along the south side of the outer quadrangle that was not directly connected with the other buildings was completely wrecked. The arcade in front of the French building on the east side and a corresponding piece in front of the Physics building on the west side of the outer quadrangle were thrown down. South of the business office, parts of the outer arcades fell. This is on the east side of the quadrangle. Parts also fell south of the Mineralogy building, on the west side of the outer quadrangle. (Plate 105A.) The arcades around the memorial court are only partly in direct connection with buildings. The free portions appear to have swayed so far out of the vertical that the bottoms of the stone columns supporting the arches were chipped off, or cracked at their bases. The 2-story woodworking shop of brick, south of the quadrangle, was badly damaged; and the forge building, next to it, also of brick and 1-story, was cracked.

The chemical laboratory, a new stone-faced building (two stories, attic and basement), was so badly cracked that most of the walls have to be rebuilt from the foundation.

The new gymnasium, a stone-faced brick building, was totally wrecked. (Plate 104B.) It had just been put up, and the inside work was not yet finished. The new library, also a stone-faced brick structure, was completely wrecked except a tower of steel on which its central dome still stands. (Plate 104A.) This building had just been put up, and was not yet finished on the inside when the earthquake occurred. The Museum building consisted of an older central portion built of concrete, and extensive additions of brick had just been completed. The new brick portions of the building were almost all thrown down, but the older concrete part was unhurt.

The ornamental stone gateway at the entrance to the university grounds, near Palo Alto, was thrown down. (Plate 101B.)

The water-tank at the Faculty Club-house was wrecked and a water-tank in the fields east of Alvarado Row was overthrown. The large covered tanks west of the stock farm, beside the county road, were not thrown down, but much water was spilt from them.

*Palo Alto* (A. F. Rogers). —The most interesting effects of the earthquake in Palo Alto were those which showed movement of buildings and those which gave evidence of twisting. A number of buildings moved toward the southeast 1 to 6 inches or more. Some buildings were left out of plumb and usually they were inclined to the southeast. In other cases, buildings collapsed and fell toward the southeast. It should be remarked that practically all houses moving to the southeast were those situated on the streets running northwest-southeast. Very few buildings on the avenues (running northeast-southwest) were moved at all. The moved buildings stand approximately at right angles to the fault-line southwest of Stanford University.

A change in the direction of the earthquake movement is suggested by the fact that in several cases the chimneys were apparently twisted from their normal positions. The same is true of several houses that collapsed. The twisting was clockwise in some cases and counter-clockwise in others. A remarkable case of twisting was shown in the house at 727 Cowper Street, where picture frames were tilted from the normal positions.

Chimneys were mostly knocked down, those that remained standing being for the most part in the centers of the houses. The direction of their fall was apparently accidental. A curious case is that of three 1-story frame houses, exactly alike, at 317, 323, and 329 High Street. The chimney on the house at 329 remained standing, while the chimneys on the other two houses fell.

The data upon which those conclusions are based follow:

757 Channing: Small one-story frame house without foundation; chimney standing.

845 Webster: One-story frame house with wood foundation; chimney standing. Chimneys were thrown from the two one-story frame houses next to it.

4M Middlefield: Two one-story shingle houses; chimneys standing.

427 Middlefield: One-story house; chimney in the center of the house stood. Next door, same kind of house, chimney at end of house fell.

427 Hamilton: One and one-half story frame house; chimney in center of house stood, while one at side, of house fell.

427 Hamilton: Two-story frame house; chimney standing.

Hamilton and Middlefield: Two and one-half story frame house; chimneys standing. Chimneys down in houses around it, both one-story and two-story houses.  
 368 Lytton: Very small frame house without foundation; chimney standing.  
 Hawthorne near Waverly: Several small houses; chimneys in center of houses standing. Side chimneys on small houses across the street from these were down.  
 171 Cowper: Tiny one-story frame house; chimney on side of house standing.  
 317, 323, and 329 High Street: Three one-story frame houses exactly alike, and chimneys in same positions on houses. Chimney at 329 standing; the other two down.  
 310 High: One and one-half story house; chimney in center standing, one on side down.  
 Kingsley and Bryant: Two-story stucco house; chimney standing. No damage.  
 1329 Waverly: Low one-story shingle house; rather high chimney standing.  
 Boyce Avenue: Two-story rather low frame house; chimney standing.  
 Guinda Street: Two frame houses, one one-story, other two-story; chimneys standing. Chimneys fell from houses on both sides.  
 Hamilton and Fulton: One and one-half story frame house, chimney cracked but standing. Very small house next to it, chimney down.  
 465 Hawthorne: One and one-half story house (first story brick); apparently no damage except chimney down.  
 347 Melville: Two-story stucco house; chimneys all down.  
 Forest Court: One very low frame house; chimney down.  
 253-255 Homer: Two-story double stucco house; plaster slightly cracked, chimneys down.

## EVIDENCES OF TWISTING.

1110 Bryant: Small one-story frame house; chimney at center of house twisted slightly counter-clockwise.  
 121 Emerson: Small one-story frame house; chimney in center twisted clockwise.  
 Waverly near Lytton: The Palo Alto Academy, an old two-story frame house, completely collapsed, falling toward the southeast and apparently twisted counter-clockwise.  
 Emerson, near University Ave.: Two-story frame house was moved off its foundation toward the southeast, and twisted clockwise.

711 Cowper: Pictures on walls; some remained straight, others were twisted as shown in the sketch, showing the four walls of the room. The pictures on the northeast and southwest walls were observed in one room and those on the northwest wall in another room. (See fig. 55.)

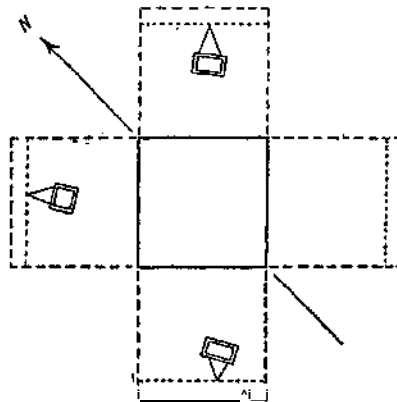

FIG. 55.—Diagram showing displacement of pictures on walls of rooms.

## MOVEMENT OF BUILDINGS.

627 Waverly: Two-story frame house high above the ground and resting on brick foundation; lower part of house moved toward the southeast so that it had to be propt up.  
 711 Cowper: One and one-half story frame house high off the ground; 6 inches out of plumb in rear.  
 745 Cowper: One and one-half story frame house, high off the ground; several inches out of plumb.  
 538 Emerson: Two-story frame house; first story moved 2 inches toward southeast.  
 439 Alma: One-story stable moved a little to the southeast.  
 129 Emerson: Two-story frame house several feet above the ground was moved 3 feet toward the southeast and set down on the ground.  
 Luscher Building, 251 High: Two-story frame building; moved toward the southeast several inches, and apparently twisted counter-clockwise.  
 Palo Alto Hotel, Alma and Lytton: Three-story frame hotel moved toward the southeast.  
 Greenhouse, near San Francisquito Creek: Very little damage; a few panes of glass broken. The benches moved toward the southeast from 0.5 to 1 inch.  
 Ruthven and Cowper: New one and one-half story shingle house with concrete foundation; chimneys standing. House propt up on southeast side.  
 Dudfield Lumber Yard: Piles of lumber moved in various directions, but mostly toward the southeast.  
 Forest and High: Lumber shed; lumber piles on each side of open central space partially collapsed. Lumber piles on northwest side moved toward the southeast; those on southeast side remained in place.  
 Bleiber Blacksmith Shop: Two-story frame building; lower story moved 4 inches toward the southeast.  
 Alma, west of University: New three-story artificial stone building fell toward the southeast.  
 Alma, east of University Avenue: New two-story artificial stone building; collapsed and fell toward the southeast.  
 444 High: Two-story brick business house; first story moved toward the southeast.

## MISCELLANEOUS.

The bridges across San Francisquito Creek, at Bryant Street and Middlefield Road, apparently were not damaged.  
 University Avenue and Romona Street: Jordan Building; three-story stucco business building. Plaster on first story badly cracked.



A. Enin of Memorial Arch, Stanford University. Per J. O. B.

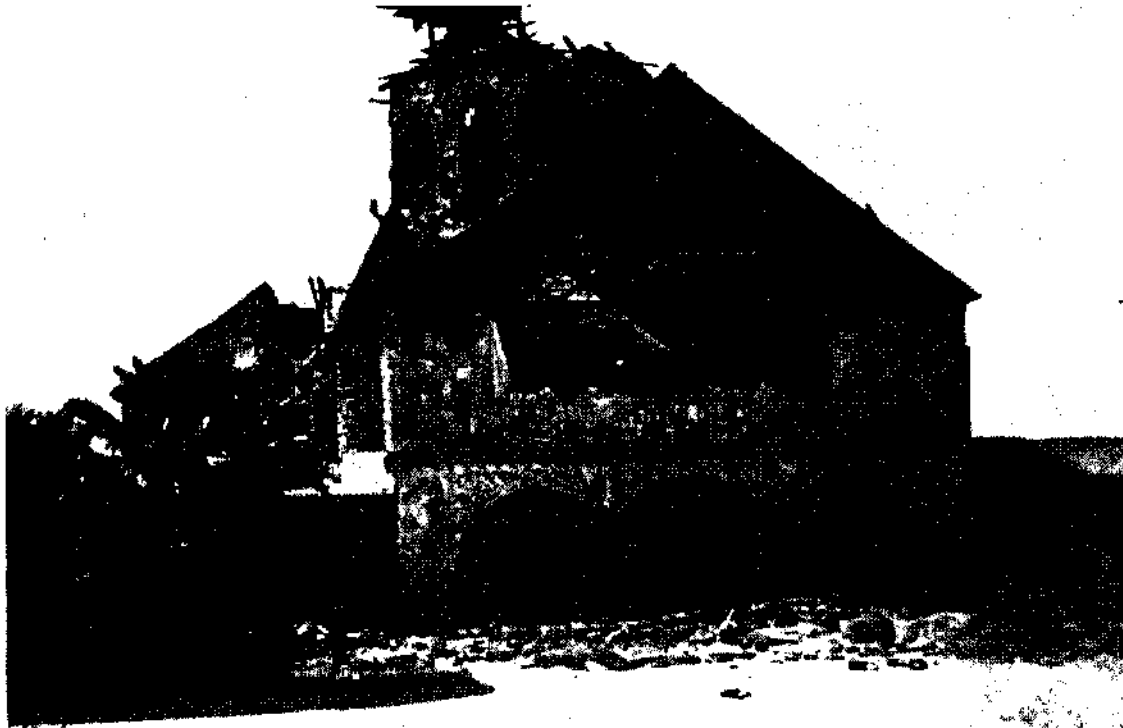

B, Front Yiew of Memorial Chare!, Staoford Unimrtitj,

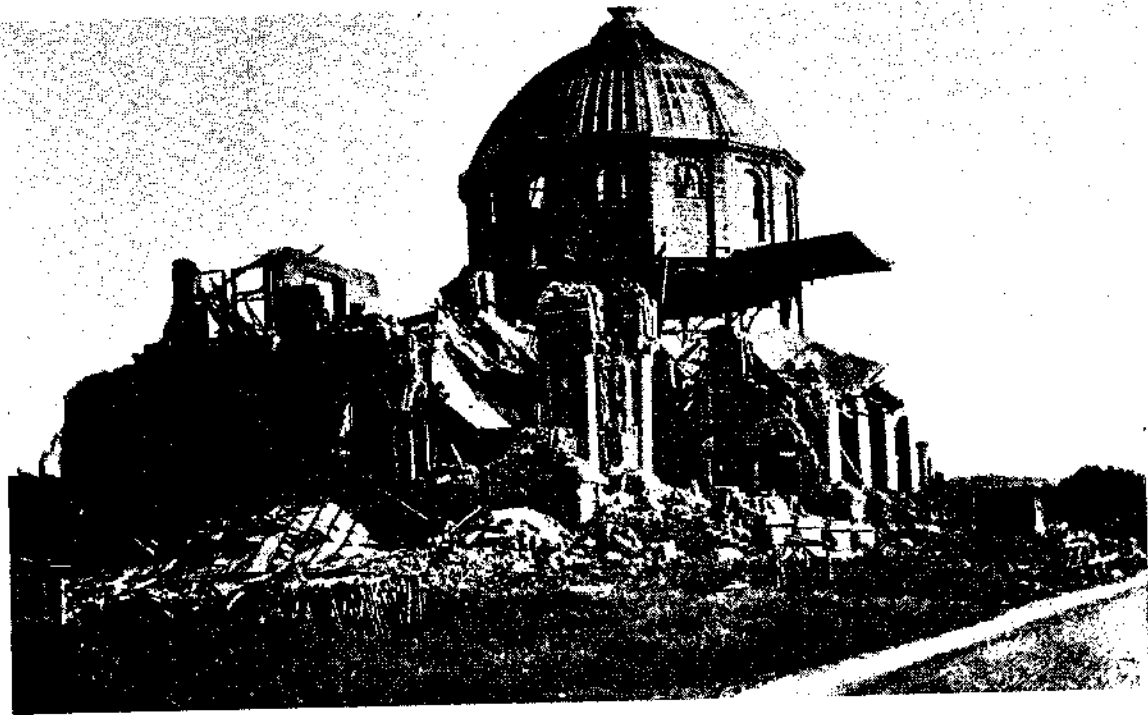

A. "Wreck of Library Building, Stanford University. Par J. O. B.



B. Wreck of Gymnasium Building, Stanford University. Par J. O. B.

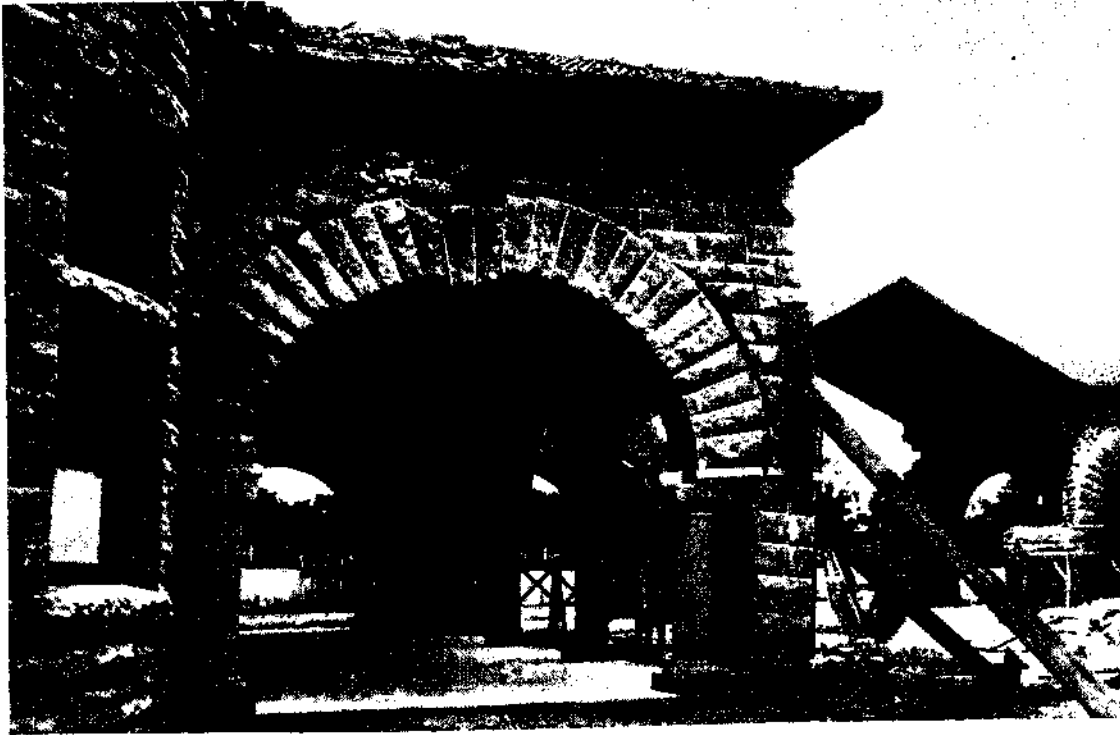

A. "Wrecked arolea, Geology Building, Stanford University. Per J, O. B.



B. ATches that mored on their supporting oolmnni. Stamford Uniwwity PMJ- • B.



A. Tree oTerthrown by earthquake, west of Searsville Lake, Per J. O. B,



B, LIT« oak uprooted \tj eartbqmfa, weit of Beawill\* Lake. Per J. G. B.



*Menlo Park* (H. P. Gage). —At the Catholic Seminary near Menlo Park, a 4-story brick building, the upper part of many of the walls fell; towers and chimneys also came down; arches were sprung apart, allowing their keystones to drop, catch, and hang. There were many cracks in all the walls which remained standing; the capstones above the windows on the fourth floor fell out. The chapel behind the northeast side wall was thrown in a heap. The 1-story brick buildings back of the large one were little damaged; a wooden tank was uninjured, altho it was on an 80-foot tower like the one in the building which fell. The round power-house chimney (35 feet high) was cracked in the middle and the top broken off. A mile nearer Fair Oaks Station, a water-tank only 12 feet high was thrown down. With this one exception all the tanks on this side of the county road appeared to be standing.

(F. Lane.)—A water-tank beside the road, passing north of the cemetery 1.5 miles southwest of Menlo Park Station, was thrown down; while one about 0.25 mile nearer the station on the same road was left standing. On the second road west of San Francisquito Creek, and running southwest from Menlo Park Station toward the Alameda de las Pulgas, three large trees growing together had been torn apart, and one about 2.5 feet in diameter had fallen. Water-tanks on the second road west of San Francisquito Creek were not thrown down. On the second parallel road west of the Creek, and leading southwest from Menlo Park and 1 mile from the station, the roof of a large 3-story brick house, which had been recently built, had collapsed, the bricks having been shaken from the walls down to the second floor. The Arcade of the Sacred Heart Convent was thrown down. (Plate 101A.)

*Fair Oaks*. — On the road leading southwest from Fair Oaks and about a mile southwest of that station, a newly completed 1-story bungalow had entirely collapsed.

(S. Taber.)—At a stable near Fair Oaks (about a mile southeast of the junction of the Woodside Grade road with the road leading across University Heights) heavy carriages and wagons were moved sidewise 6 inches in a direction N. 37° E., but they did not roll out on their wheels. These carriages were placed on the northwest side of the barn.

(H. P. Gage.)—Following the road from Fair Oaks toward Cooley's Landing, a house with poor underpinning fell over, also the woodshed near it. An engine mounted on a platform 2 feet from the ground was not upset. People reported new holes formed in the slough near Cooley's Landing, but their statements were not verified. No damage except broken chimneys was noticeable in the vicinity of the Landing, and solidly built houses seemed to be intact. One house on a poor foundation was knocked down; while the barns, tanks, etc., belonging to it were uninjured.

(F. Lane.)—South of Menlo Park and east of the Meyer Place on the west side of San Francisquito Creek, a crack about 1.5 inches wide ran for 20 feet along the edge of the county road parallel to and just above the creek, showing a half-inch vertical displacement, the lower side lying next to the creek. This crack appears to be due to the starting of the filled ground of which the road is partly made. The water in the reservoir of the Bear Gulch Company, 3.25 miles west of Stanford University, is reported to have been thrown about 25 feet beyond the dam on the southeast side of the lake. Water-pipes along the road leading from the reservoir toward Menlo Park had been pulled apart. The buildings in the neighborhood of the reservoir are of frame, and no great damage was done to them, except that the brick chimneys were thrown down.

*Redwood* (R. V. Anderson). — The intensity of the earthquake in Redwood City was about IX. Many buildings were partially wrecked and the new court-house was completely ruined. Over 40 houses in the town were moved upon their foundations and a majority of the houses had the plaster badly cracked. Ninety-four per cent of the chimneys fell, and dishes and similar objects were universally thrown down. Along the two roads leading from Redwood to Portola, out of 23 big public water-tank\* U) were thrown down.

*East of Palo Alto* (S. Taber). — On the Embarcadero road, from the railroad crossing at Palo Alto toward the Bay of San Francisco, only about half the brick chimneys had been thrown down. Plaster on first-floor walls cracked, but it was not injured to any extent in the upper stories. Many houses showed little damage to plaster, even on the first floor. The tanks of the Palo Alto Water Company (at 1, map No. 22) had not been thrown over, but the frame (100 feet high) had slipt on the concrete foundation a maximum distance of about 0.5 inch in a direction N. 87° E. The water is reported to have slopt out of the reservoir on the east side. A water-tank about 0.5 mile nearer the bay (at 2, map No. 22) was standing, as was a brick chimney near it. Damage to houses in this section was directly due to high brick chimneys; plaster was sometimes scarcely cracked, even on the first floor of houses thus damaged.

*Mayfield to Guth Landing* (R. L. Motz). — In the town of Mayfield most of the houses are small, 1-story buildings resting on wooden foundations, and many of the chimneys were of terra cotta and wired to the roofs. Out of a total of 258 chimneys 183 fell — about 70 per cent. A few brick buildings were badly cracked, and the fire-walls were all thrown off. The plaster in the small buildings was somewhat cracked, while in the larger buildings the damage done to plaster was more marked. The concrete bridge over Madera Creek, on the county road 0.5 mile southeast of Mayfield, was not cracked. A half mile further southeast along the road, 2 water-tanks and 3 chimneys (2 brick and 1 cobble-stones and lately built) were standing. A short distance nearer Mountain View Landing there were fallen or damaged chimneys (at 4 and 5, map No. 22).

At Guth Landing a large brick warehouse facing N. 87° E. had its sides cracked, lost a few bricks at the top, and had the upper part of its east and west ends knocked out. From Guth Landing southward along the road into Mountain View, the effects were uniform; chimneys were down with two exceptions, there was little or no damage to plaster, and the flow from bored wells had increased. In one case a wind-mill (at 6, map No. 22), which had been in use for years to pump water from the well, was no longer found necessary, but the artesian water was muddy.

*Mountain View* (H. P. Gage). — On the county road between Mayfield and Mountain View, concrete bridges were uninjured, water-tanks were left standing, and the smaller or more solidly built chimneys uninjured.

(R. L. Motz.)—In the new town of Mountain View, built mostly in the vicinity of the railway station, 6 brick structures, including the Pacific Press and the cannery buildings, were seriously injured. Out of 271 chimneys, 206, or 76 per cent, fell; out of 46 large water-tanks 20, or 43 per cent, fell. In the Mountain View Cemetery there were 26 large monuments; of these 11 fell and 7 were shifted, while 13 slab headstones out of 27 were thrown down. In the village of Old Mountain View 75 per cent of the chimneys (31 out of 41) fell, and 33-J per cent of the water-tanks (3 out of 9) fell.

(H. P. Gage.)—On the road leading southwest toward San Antonio Creek from the town of Mountain View, the houses showed no uniform damage. At one place south of the county road and two miles west of the Mountain View Station, the water-tank swayed and threw out several barrels of water during the shock, yet the plaster in the house was unhurt and only a few dishes were broken. At the next house, the chimney fell.

At the Weeks poultry ranch 2 chimneys fell, dishes were broken and plaster was cracked; but the water-tank was uninjured.

Two and a half miles southwest of Mountain View Station, beside the road running up San Antonio Creek, a water-tank was so badly wrenched that it had to be braced to keep it from falling; another tank, on a side hill west of San Antonio Creek, had collapsed. The house near the latter, in course of construction, lost an outside chimney. Following the road up San Antonio Creek on its southeast side, another house between the road and the creek had one chimney cracked and another thrown down; plaster had

fallen in the second story, and sewer and underground pipes were broken. Much damage was also done to the houses on the hill southwest of where this road crosses San Antonio Creek. In one of these 3-story houses, the plaster was partly off the first floor walls, and windows were broken. The second house was so shaken that it shifted several inches upon its foundations. A 1-story cottage close by was little damaged; and in the pumping shed, bottles, cans, etc., standing on a narrow shelf did not even fall down. The chimneys were thrown down on the ranch house at Hidden Villa, two miles northwest of Black Mountain Triangulation Station, but there was no great damage otherwise. Big blocks of rock are said to have been shaken loose from the mountain and to have rolled down the slopes. One of these rolled into the chicken-house, and others broke the water-pipes at several places farther up the gorge.

On the road running southwest from Mountain View Station toward San Antonio Creek and 1.75 miles southwest of the station, a water-tank 8 feet high was thrown down. In the village of Mountain View, 0.5 mile southwest of the railway station, one chimney on a small house, and projecting 5 feet above the roof, was left standing; while another chimney on the same house was thrown down. On the road leading north from Mountain View, and 0.25 mile from the station, one chimney fell; but another, 1 x 2 x 3 feet was standing. The latter was braced with iron bolts, however. The plaster in the house was cracked, though not very badly, and the foundations were unhurt.

At the Ynigo ranch, 3 miles northeast of Mountain View Station, the house is large and old. Here the chimneys fell, one going down through the roof. The plaster was only slightly cracked. Frail sheds and water-tanks 20 feet high on light supports were not thrown down, and plumbing in the house was apparently undisturbed. There was an artesian well at this place which had, before the shock, flowed only slightly or not at all, and a wind-mill was used to raise the water. After the shock, it was found that the casing had been shoved up 2 feet, damaging the pump. The flow of water was increased and black sand was brought up. Another well at this ranch was unaffected.

At Jagel Landing there was but little damage. One chimney was unhurt, and another was slightly twisted.

The concrete bridges over Permanente and San Francisquito Creeks showed no new cracks. In the low lands northeast of Mountain View, all the chimneys except one at the Mascot Gun Club preserve had been thrown down, and water-tanks had fallen except where they had been especially well braced. The same was true in the vicinity of Sunnyvale. Between Sunnyvale and Lawrence a brick winery was destroyed, and a tank and wind-mill were thrown to the ground. On the second east-and-west road directly south of Sunnyvale, for a short distance toward Stevens Creek, a few chimneys were left standing; but the damage was generally uniform as reported above.

(F. Lane.)—A 3-story brick wine distillery in the northeast corner of the San Antonio grant, 3.5 miles south of Mountain View Station, was totally destroyed by the shock. This building was on the side of a hill. A 3-story frame house near it lost its chimney and was tipped to one side. A half-mile south of the winery, a water-tank beside the road had been destroyed. At the southeast corner of the same grant, a 2-story frame house (Selling's) was thrown from its 4-foot brick foundation and badly damaged. The road in front of the house was cracked, but probably on account of the steep slope below the road. South of the house, across Stevens Creek, there was a landslide 100 feet in width on the steep face of a bluff.

(S. Taber.)—The concrete bridge over Stevens Creek on the county road below Mountain View was not cracked, but at the brick yard, at the junction of the San Jose road with the road to Jagel Landing, a high chimney and a pile of brick had fallen over.

*Saratoga to Congress Springs* (F. Lane). — At Saratoga some chimneys were knocked off, but among those standing was a high chimney built on the side of a 1-story house. A wind-mill with a large tank had not been injured and no other damage was apparent.

On the Azule Springs road, all the 1-story buildings appeared to be in good condition, and few effects of the shock were noticeable. Near the place where five roads fork, one mile north of Azule Springs on the road running southeast from the forks, there was a 6-foot drop on the road caused by a section sinking in a solid piece on a long slope, without much disturbance in its vicinity. At the cross-roads halfway between Saratoga and West Side, the Lincoln school-house, on wooden supports, was thrown from its foundation and badly damaged. The tank behind the school-house was standing, as were all the tanks on the road from Saratoga to West Side except the one nearest the latter village. Only one more effect of the shock was noted in this vicinity; namely, the bridge over Stevens Creek, on the road running due east and west from West Side, was rendered unsafe for horses by being shoved a foot out of place.

On the Stevens Creek road, just after leaving the Saratoga road, one house near the junction of the two roads was shaken and dishes were broken, but the brick chimney was intact. Near the house a crack 2 inches wide showed a downthrow of 2 inches on the west side. A vacant house at the next turn, 0.5 mile southeast of Stevens Creek, had lost its chimney and leaned with the slope of the hill. Near this house a large area of ground, extending for 150 feet, had been torn up in a direction of N. 3° W., and a slide formed which almost blocked the road.

At the Borger place on the Stevens Creek road, the chimney was shaken down; the house, which stands on a high but well-built stone foundation, was not damaged otherwise. Wine was spilt in the cellar by the force of the shock. Further northwest along this road other disturbances were noted with increasing frequency; small cracks cross the road due north and south.

On the northeast side of the creek, 0.25 mile south of the place where a road turns northeast from the Stevens Creek road to go up Monte Bello ridge, there was a large landslide about 0.5 mile long and terraced from the top of the mountain.

The short road which runs northwest along Stevens Creek for a couple of miles beyond the junction with the cross-road which connects with the Monte Bello ridge showed an exposure of serpentine with cracks running along it N. 3° W. The cracks at the widest point measured about one foot. In the serpentine area the ground was badly broken up, and in one place it was covered with 3 feet of water. (Observation made April 22-23.) Following the road northwest beyond the terminus shown in the map, many cracks were seen, due to big landslides. Fallen trees have rendered the road impassable; boulders and dead trees still fell occasionally; even while the observer was there a large tree fell not 10 feet from him, loosening rocks and soil.

Just south of the two houses near the southern end of the cross-road leading toward the Monte Bello road from the Stevens Creek road, a break ran due east and west; it was 2 inches wide with a downthrow of 0.25 inch on the west side. Only dishes were broken in the house, a 1-story frame structure without chimneys, tho it stands above the big slide which was just mentioned. Another crack 4 inches wide was found in the road above the house.

The village of Congress Springs had not been shaken very badly. All water-pipes and tanks were intact and very little timber seemed to have fallen. The car tracks on the curve near the path to the spring had been thrown over toward the bank for about 20 feet of the curve, a 4-inch displacement resulting. The 2-story stone building of the Saratoga Wine Company was partially thrown down, and the side nearest the road had to be propped up to keep it from falling. At this point several cracks were noticed in the loose alluvial material of the road, almost at right angles to each other.

*Stanford University to Portola and Woodside* (S. Taber). — Going southwest from Stanford University along the road leading up San Francisquito Creek (at 8, map No. 22), on the banks of the creek many dead limbs were broken from trees, and a dead oak

2 feet in diameter was broken off about 20 feet from the ground. But little damage was done at a house a short distance farther west. On the north side of the creek (at 9, map No. 22), the 12-inch cast-iron pipe of the Stanford University water-main, buried about 3 feet deep, was cracked, allowing the water to spurt 20 feet into the air.

Beside the road just west of Searsville reservoir, a living white oak 6 feet in diameter was uprooted by the jerk of the earthquake shock. (Plate 106A.) At the Searsville dam the waste way is 45 feet wide. The water running over the spillway was 4 inches deep before the earthquake, but afterward it increased to 5 inches; more water was also noticed in the creek that empties into the lake.

The Preston residence, about 0.5 mile south of Searsville Lake, lost its chimneys. Along the road leading from Searsville Lake southeast thru Portola, the water-tanks were all thrown down, except one near the junction of the Portola road with the Alpine road.

The bridge at the north end of the village of Portola had the ends thrust together so that the planks forming its floor were thrown out of place. In Portola, brick chimneys were all down and water-pipes were broken. The Portola store was thrown off its foundation. The Catholic Church in the village is a frame building that stood upon an underpinning of posts about 3 feet high. This building was thrown bodily about 2 feet toward the north, apparently thrust over by the underpinning when it gave way. The Portola school-house was also thrown from its foundation, which was about 3 feet above the ground. Two small dwelling-houses southeast of the school-house and on the south side of the road were thrown from their foundations.

Following the Portola road from Portola toward Woodside, the houses showed considerable damage, with chimneys down. The water-tank at the fork of the road in front of Mr. Preston's house was thrown down, and the big tank at the fork of the road, at the site of the old village of Searsville, was also thrown down. The white oaks in the field north of the road had also many large branches broken off by the shock. A shanty between the 2 bridges (at 11, map No. 22) was down flat; and in a few cases the underpinning of houses had given way, the houses having settled in consequence. Small trees were overturned and fences broken. A large live oak had its top broken off about 20 feet from the ground (at 12, map No. 22); at the place of fracture the tree is about 3 feet in diameter.

Taking the western road past Newman's, which is at the place where this road crosses Bear Creek, from Searsville Lake to Woodside, two especially well-built water-tanks beside the road, tho well shaken on their foundations, did not fall. On the south side of the road, about 0.25 mile southeast of Mr. Folger's, a large live oak was torn up by the roots (plate 106B), while several eucalyptus trees had branches jerked off. A strongly built 1-story house just below (13, map No. 22), and within 400 feet of the fault-line, lost all of its chimneys, but the plaster was only slightly cracked. Beds and other furniture in the house were jerked in directions parallel to the fault-line. A small bed standing in the northwest corner of a room was not moved, but a larger bed near the center of the same room was moved several feet. A water-tank a short distance northwest of the house, new and strongly built, about 15 feet above the ground, had nearly all of the water spilt out of it. An eye-witness says that the water was thrown high up on the northwest and southeast sides. The water-pipe running from the house to the pump was bent in a curve toward the northwest, and where it entered the pump-house, the boards were broken on the southeast side of the pipe. The other pipe (also 4 inches in diameter) had the threads stripped off at a joint, and the ends of the pipe pulled apart for a distance of 2.5 to 3 inches. The pipe was new and buried a few inches below the surface of the ground. A large oak tree standing 200 feet or so from the house had large limbs broken off by the shock. At the Folger place, between Newman's and Portola, the chimneys were all thrown down.

On the west side of Bear Creek and north of the road along the foot of the mountain near Woodside, a 1-story sandstone house had its south wall thrown down, and was otherwise badly damaged. About 50 feet of stone wall, laid with mortar, along the side of the road, 3 feet high and 1.5 feet wide, was thrown down. A tank at the cross-roads in Woodside was left standing. The upper part of a brick winery 1½ stories high (at 26, map No. 22) was demolished, the roof being split down the middle and smashed to pieces. A house 1½ stories high (at 14, map No. 22) was thrown toward the southeast, the underpinning giving way in front. The house was badly damaged. Water in a large tank near the house spilt out on the southeast and northwest sides.

At the very end of the short, crooked road mapped as running northwest from the village of Woodside, there was a well-built 1-story frame house, of which the brick chimney had been thrown down; the plaster of the house was only slightly cracked. Near this a large water-tank was thrown over; another remained standing but had the shingles knocked off the roof on the northwest side by the force of the water dashing up against it. The old adobe house at the cross-roads in the village of Woodside was thrown down, the posts and supports left standing leaned at a considerable angle toward the northwest.

A large frame house (Mr. Josselyn's residence), north of the road and close to West Union Creek, was demolished; while another on the opposite side of the road, and just south of the bridge, was not badly damaged. The concrete bridge over West Union Creek, 1 mile south of the point (14, map No. 22), showed a few small cracks. From this point on up King's Mountain road, as far as the summit, there were no cracks nor landslides.

*Page Mill and Alpine roads* (S. Taber).—All brick chimneys along the upper part of this road were thrown down. At the Clarita Winery crockery was broken and milk spilt from pans. On the road from Clarita Vineyard to the Allen place (at 18, map No. 22), several small cracks 0.25 to 0.5 inch across ran east and west; numerous cracks intersected (near 18, map No. 22) in various directions, while some large ones running parallel to the contour lines were probably due to earth slipping. Judge Allen's in the valley, and several smaller houses, were thrown from their foundations and otherwise badly damaged.

Following the Alpine road up Corde Madera Creek, cracks were common on the outside or filled portion of the road, and these were generally parallel with the embankment. The steep southern slope of the ridge just north of the Alpine road, along its lower course, was favorable to landslips. At many places huge masses of rock had been thrown down from these steep bluffs into the road, completely blocking it up. On the south side of the creek the slopes were not favorable to landslips, but there were several of them; and at one point, about a mile from the summit of the ridge where this road enters the Page Mill road, one slide carried away the entire roadbed for a distance of about 300 feet.

(H. P. Gage.)—Following the Page Mill road westward from Black Mountain toward Langley Hill, a 1,000 gallon tank was undisturbed, but 3 live-oaks near by were uprooted, one of them being a large tree with a 12-foot base. These trees were in a rather dry soil, yet none of a grove of trees growing in moist soil was overturned. Farther west up the road which loops toward Langley Hill, a big crack running east and west, caused by a slide, showed a drop of 8 inches on the north side; and from here on down to the Alpine road the road was badly cut up with slides, but was not impassable. On the steep grade of Langley Hill a slide had moved 30 feet. At the ranch houses there was little damage done by the shaking save sometimes a fallen chimney or a few broken dishes. At one ranch the people reported that cows were much frightened during the shock.

(F. Lane.)—Along the ridge road southwest of Stevens Creek, separating Santa Clara and Santa Cruz Counties, there were some cracks due to landslides. Sandstone blocks, some of them 6 feet in diameter, had rolled down the hills toward the creek. People at the houses along this road stated that the shaking had been severe, with loss of a few

chimneys but very little destruction otherwise. No evidence of cracks could be found upon the side road. At a house situated at the junction of four roads about 3 miles west of Congress Springs, no damage was reported, tho the inhabitants were up at the beginning of the shake and say that it was accompanied by considerable rumbling and that the shocks which followed were preceded by a sound like a blast.<sup>1</sup>

*King's Mountain down Purisima Creek* (S. Taber). — At King's Mountain House, brick chimneys were knocked down and some dishes were broken, but no damage was done to the house. Cream was spilt from the milk pans on the southwest side. On the Cahill Ridge road leading northwest from King's along the crest of the ridge, little damage was noticeable. An old woodshed was thrown down (at 21, map No. 22), and about a mile farther on the top was broken from a large redwood tree about 75 or 100 feet from the ground (at 22, map No. 22).

Following the trail from King's Mountain House down Purisima Creek, a large slide on the northeast side of the creek had filled the road to a width of about 100 feet (at 23, map No. 22). The buildings at Hatch's Mill, just below (24, map No. 22) were not damaged, but a little farther down several cracks were found, one 8 inches wide and running S. 23° E. On the northeast side of the creek, just below Borden's Mill, a big slide had dammed the creek to a depth of 25 or 30 feet (at 25, map No. 22). The slide was between 0.25 and 0.5 mile long. The buildings at the mill showed no damage, but a bridge just above the mill was crushed by a slide from the south side of the creek.

*Bear Creek* (H. P. Gage). — Between Redwood City and Woodside, all of the public water-tanks were thrown down or had to be rebuilt. On the Bear Creek road, southwest of Woodside, there were many cracks caused by landslips down steep banks. The tops of 2 partly decayed trees, one a redwood and the other a spruce, had been broken off where the diameter was 2 feet. Near where the first trail branches to the right from this road, an old oven built of clay and stone, 4 feet high, was cracked, and an old barn was badly damaged. At the point where the road itself becomes a trail there is a log cabin, probably used as a summer camp. This cabin was locked and had apparently remained undisturbed since the earthquake. The floor is about 6 feet above the level of the ground. Table, benches, chairs, and all the bottles and utensils, except a coffee pot, were overturned. The table was solidly built and measured 4 by 8 feet. About a mile east of this cabin, at the end of another trail, was a 1-story frame house; a bed on the first floor was moved by the shock 8 feet to the middle of the room, tables and chairs were displaced, and dishes were broken. A house and dairy between this place and the road were moved on their foundations, and water was spilt out of pails from northeast to southwest. Tops of spruce trees were broken by the shock. Four miles farther southwest, along the trail toward the San Gregorio road, people reported that all the stoves on the first floor of their houses were overturned during the earthquake, with the exception of a kitchen range which was twisted around 6 inches. Their dishes were also broken. Just south of the junction of this trail with the San Gregorio road, a 2-story house had been shifted on its underpinning and some plaster was broken. A water-tank 20 feet high fell at this point.

*Half Moon Bay, Purisima and San Gregorio* (S. Taber). — Following the road along Pilarcitos Creek toward Half Moon Bay, many cracks and slides were found on the ocean side of the ridge, but few on the east side. All of these seemed due to slipping of the earth. At one place there had been such a large slide that big blocks of sandstone had fallen down into the road. Here and there along the road big cracks had opened, parallel with the road and the creek where the slope is very steep, and promising to make the road impassable by landslides, should a heavy rain come.

---

<sup>1</sup> Mr. Lane adds: "While I was there, however, we had a slight shock and I noticed neither blast nor noise."

Just north of the bridge over Pilarcitos Creek, north of the town of Half Moon Bay, an adobe house west of the road was thrown down by the earthquake, killing 3 people (at 30, map No. 22). The concrete bridge was badly cracked, as were the approaches at both ends. Just south of the bridge, several small cracks in the low ground west of the road permitted water to spout up, bringing sand with it. In the town of Half Moon Bay many buildings were badly damaged, some old frame houses and the brick bank building being flat, while the upper half of a 2-story brick structure was demolished. The Mosconi Hotel, a 2-story frame building, had plaster shaken from the side walls of the first floor only, while the ceilings of these rooms were not cracked.

In Half Moon Bay it was reported that there was no evidence of any change of level along the coast. The streams on the west side of the mountains were said to have doubled in volume. The road along the coast from Half Moon Bay to San Gregorio showed comparatively few traces of the earthquake. The concrete bridge over Canada Verde (at 31, map No. 22) was slightly cracked, and 0.5 mile farther south a water-tank lay flat across the road.

At Purisima the chimneys were all down, and crockery was broken. The intensity of the shock was apparently less at Purisima than at Half Moon Bay. According to various reports, a crack east of the road below Purisima, due to a landslide, extended for about 1,000 feet nearly north and south; and an earthslide on the side of a hill a mile or more farther south was about 100 yards long and 80 feet across.

At San Gregorio very little damage was done. The hotel lost only a little plaster and a few dishes. Turning eastward on the road along San Gregorio Creek, traces were found of increasing intensity. A mile from the town of San Gregorio, a water-tank 20 feet high was still standing, while a couple of miles farther east the creek was dammed up to a depth of 6 feet by a slide from its southeast bank (at 32, map No. 22), and all chimneys were down. Miss L. E. Bell reports that near Bellville a small alkali flat was raised about 3 feet. There was a landslide into the road for a distance of 300 feet, the height of the slide being 100 feet (34, map No. 22). Chimneys and tanks all thru the valley were thrown down.

(G. A. Waring.)—Of the 2 stores at San Gregorio, the one in the bottom-land suffered most, nearly all the shelf goods being thrown down. Cracks from 12 to 18 inches wide appeared in the cultivated bottom-land, and a water-tank was shifted on its platform 8 inches northward. In the Lobitos saloon a slot machine was hurled to the floor, and nearly all the bottles on a shelf running east and west were thrown off. Small cracks appeared in the ground at Lobitos, and a small slide occurred in the road 0.25 mile up the stream.

*La Honda* (H. P. Gage).—The inhabitants say that after the shock the creek rose about 4 inches and became muddy. At the hotel, plaster fell from first floor walls; the rest were little damaged. The plaster had already been cracked, however, by raising the house. Lamps were all shaken off the tables, and all the chimneys were down. Water spilt from the horse-trough in a northeast-southwest direction.

Near the Weeks ranch house, between La Honda and the summit of the ridge on the road leading to Redwood, an inconspicuous crack was noticed running east. It was about 2 inches wide, with no vertical movement evident. The north side of the crack, however, had moved fully 3 feet eastward. The crack simply marks a big slide which has been slipping for years, and which descended 3 feet during the earthquake. The Weeks house, a strongly-built frame structure, 2| stories high, was badly damaged. A large outside chimney fell thru the roof to the first floor, and the plaster was fairly stripped from the lower rooms and somewhat cracked upstairs. The sliding doors downstairs were shaken off their tracks, several windows were broken, the front door was cracked, and many of the door jambs were broken. The heavily built barn near the house was



badly strained. The water in the reservoir was spilt from northeast to southwest. In an old house near the summit the stove was not moved at all, but the chimney built 40 years ago fell.

(S. Taber.)—For some distance on the west side of the summit sandstone blocks had been cracked off and scattered across the road. From the summit of the ridge to the Portola Valley, the only effects noted were the wreck of a ramshackle old barn and a 3-inch crack across the road (at 36, map No. 22), probably due to settling.

*Congress Springs to Boulder Creek* (B. Bryan). — From Congress Springs, following the road that passes along the valley, about a mile east of the Castle Rock Ridge, in a southeasterly direction toward the reservoir of the San Jose Water Company, evidences were found that the earthquake had an intensity of over IX. The walls of a stone barn had been thrown down, 1,000-gallon wine-tanks in a cellar had been shifted, and people in the houses were thrown down while trying to get outdoors at the time of the shock. In a house close by, at the south end of the dam, the first floor plaster fell. Poorly built foundations fell. Southeast of the reservoir the chimneys and water-tanks were down. Two water-tanks at and near the bend of the road (at 37, map No. 22), were standing, but 0.5 mile northwest of this place a water-tank had fallen. The water in the reservoir (at 38, map No. 22) had overflowed the 3-foot banks, but the water-tanks were standing. A short distance down the road, to the northeast of the reservoir, another tank was standing. A house 0.75 mile east of this reservoir was badly shaken, with loss of plaster and chimney. In the section a mile east of the fault-line (at 39, map No. 22) the shock was weaker. All the chimneys on cottages were standing as far as could be seen, as well as all the water-tanks. The bridges 0.5 mile southeast of the reservoir were considerably shaken. Cracks seemingly continuous in the direction of the fault-line ran thru the area 0.75 mile east of the fault-line. Two-story frame houses along the fault line 1 mile southeast of the reservoir mentioned were so damaged within that people were living outdoors; yet the shake had not broken a 6-inch flag pole on a 2-story frame house. A large redwood tree had been shaken down (near 40, map No. 22); the house near it had its chimney fractured down to the fireplace, and the stove and piano were thrown across the room. The water-pipes here were badly displaced and broken. The intensity was greatly diminished, however, near 41, map No. 22; chimneys did not fall, tho fractured; clocks were stopt; little rock was thrown down from a vertical outside wall 15 feet high.

On Deer Creek a large landslide started from near Grizzly Rock and slid westward, but changed its direction  $60^\circ$  or more farther down toward the creek. The mill in the creek bottom below the slide was partly buried, and one man was killed. It is 500 feet from the mill in the gulch to the top, at the point where the slide started. The slide covered about 25 acres of ground, and destroyed a lot of virgin timber from 3 to 10 feet in diameter. The slide material, which is 300 feet deep, is composed of soil, clay, and shale.

The shock could not have been very strong at 42, map No. 22. The houses stand on posts 10 to 15 feet high, but were not moved noticeably. Furniture facing most nearly north and south was thrown down, but not when facing in other directions. The inhabitants were badly frightened and ran outdoors without waiting to dress. On Bear Creek (at 43, map No. 22) a smaller slide had moved a few hundred feet, buried a hut, and killed one man. According to reports of men in this region, only a minute elapsed after the beginning of the earthquake before the slide was over. Down in the valley no cracks or other evidence of violent disturbance could be seen.

Farther southwest down Bear Creek, about 1.5 miles from the village of Boulder Creek, were evidences of a less severe shock. A chimney on a 1-story house did not fall, tho the furniture in the house was thrown down. Trees were violently shaken. A mile northeast of Boulder Creek a chimney on a 2-story house was down, but no buildings were moved or broken.

In the town of Boulder Creek, all chimneys were down except those on some 1-story cottages; these were cracked, however. People generally ran out-of-doors, but were not as a rule very badly frightened; some even stayed inside until they had drest. Water-pipes were not broken, but some plaster had fallen, and plaster was cracked everywhere.

Mr. Bloom, owner of a sawmill at the edge of the Big Basin, reports that the shock was less severe in the Big Basin region than at Boulder Creek; that there were no landslides on the road between the two places; and that, tho he had been nearly to the summit on the day of the earthquake, he had seen only one crack where the earth had started to slide.

(R. Collom.)—At Boulder Creek, on the east side of the stream, a small hill of about 150 feet elevation rises rather abruptly. Its sides are thickly covered with small trees and brush. Near the top, a large portion of the surface soil had been shaken loose, and had slid to the level of the creek, carrying trees with it.

At Ben Lomond no fissures nor other such evidences of the earthquake were to be seen. Inquiry showed this condition to continue in the country about the town. Broken chimneys were the only evidence. The inhabitants of Ben Lomond report several slight shocks during the night of April 21-22, 1906.

(B. Bryan.)—Going north from the village of Boulder Creek along the San Lorenzo River, only small wooden houses were seen, all with chimneys standing. There were few evidences of the force of the shock, except fallen redwood trees. Three dead redwoods had been snapped off from 30 to 50 feet above the ground; and farther on two more were noticed, one having broken and the other having been uprooted. A man who was at the sawmill, 8 miles north of Boulder Creek, at the time of the earthquake, stated that a few trees were torn up by the roots. Cordwood had been thrown down in several instances along here. A small landslide had moved across the road (at 44, map No. 22), which 20 men spent one and a half\* days clearing away. In the gulch the tops of a number of redwood trees had been broken off from 50 to 100 feet from the ground, the diameters at the point of fracture measuring from 10 to 14 inches. Up the road to the summit of Castle Rock Ridge no slides nor cracks were observed.

On Boulder Creek, coming southeast down the China Grade, the shock was strong, but apparently not so severe as along the San Lorenzo River. The people were badly frightened by the shaking, however. One man reported that no redwood trees fell and that only a few dead limbs were broken off. Near the junction of the first road leading from Boulder Creek into the Big Basin, an old landslide which covered about 2 or 3 acres, dating back to the previous winter, had been widened by the shock and its direction had changed. Only a couple of hundred yards farther down the road, some stacks of smooth split redwood logs (cordwood size) had not been shaken down.

A small earthslide had started (at 45, map No. 22), and a crack, perhaps due to the same slide, was noticed. For the next mile or so southeast, there was a considerable amount of cordwood along the road, none of which was disarranged by the shock; and no trees nor dead limbs had fallen. In the houses between this place (45, map No. 22) and the sawmill (at 46, map No. 22), the evidences of damage were more serious. At this first place visited no damage was done; people were awakened but did not get up; no trees nor limbs had fallen. At the next place, 1 mile southeast, people ran from the house during the shake and attempted to remove a sick man. Small objects were thrown down and a pendulum clock was stopt. At the house just southeast of the mill, the inside furniture was overturned, the stove moved, and the terra-cotta chimney split and fell; while branches were broken from redwood trees near the house. At the mill the same effects were noted, and others as well; tops of live trees, from 6 to 8 inches in diameter at the fracture, were broken off. From the point (46, map No. 22) down to the road leading to Bloom's Mill, 1 mile south of the point (45, map No. 22), the intensity seemed to have been less. A water-tank beside the road was quite unhurt; houses were

not badly shaken; and only small objects—cooking utensils, etc.—were thrown down. At an old mill 2 miles southwest, however, a clock had been thrown upon the floor and broken at 5<sup>h</sup> 11<sup>m</sup> A.M. Half of the piled lumber had been disarranged, and the water-tank, built on a frame 15 feet high, was shaken so that it fell the next Monday night.

*Ben Lomond Mountain to the Coast* (B. Bryan).—At the junction of the Ben Lomond Mountain road (47, map No. 22), the house was empty, but there was no noticeable disturbance in the sheds or neighboring trees, tho a few hundred yards south a few dead limbs had been recently broken from the redwoods and one or two dead trees had fallen. Some other trees were so loosened at their roots that they have fallen since the earthquake. At the Ben Lomond Wine Company, a place 2 miles southeast of the junction of the roads (at 47, map No. 22), a well-built cottage had 2 tall chimneys still standing. People did not leave the house during the earthquake. Leaving the Boulder Creek road, and crossing Ben Lomond Mountain by the Eagle Rock road, the damage appears to consist largely of fallen chimneys. Small objects, such as fruit jars, china, etc., were thrown down, but only from shelves against north and south walls. People left their houses, but were not much alarmed.

No evidences of a violent shaking were to be found on the trail following southwest down Big Creek, either in trees or buildings, except where a small, half-decayed shack had been thrown out of plumb and a set of shelves overturned in another cabin. A table near these shelves was unremoved, and the bottles on top of it were standing. At the dam on Big Creek (at 48, map No. 22), no harm had been done, nor was any damage visible in 3 old shacks just below the dam. A half mile from this point cracks caused by slides were noticed on a very steep bank. Slight damage was done to the flume (at 49, map No. 22), which 3 men repaired in half a day. A few objects were thrown down in dwellings hereabouts. Near the junction of Scott and Big Creeks, a light terra-cotta chimney did not fall, but milk was spilt from pans at this place.

(H. W. Bell.)—At a house 1 mile southeast of the junction of the east and west forks of Waddell's Creek, a brick chimney was thrown down. Near a deserted mill at the north-end of Ben Lomond Mountain, a small landslide had carried trees and brush down to the creek, and tall trees had fallen along the road. At a new mill a short distance from the old one, about a mile northwest of Eagle Rock, it was reported that the shock was distinctly felt, but no damage was done. Dishes even stayed on the shelves. A steep bank beside the road showed small cracks, which could apparently have been easily made in the loose soil.

(G. A. Waring.)—At Swanton it was reported that a distinct noise, as of a team crossing a bridge to the northwest, had been heard preceding each shock. Dishes on a shelf running northeast and southwest were thrown off, while those on a shelf standing at right angles to these were unhurt.

(B. Bryan.)—At the school-house (50, map No. 22) the globes were overturned by the shock. The teacher said that she had heard from the people at the end of the trail just above, leading northwest toward Swanton, that the shaking had overturned only a few glasses, and that their pendulum, clock did not even stop. At the next place, 0.5 mile southeast of the school-house, no damage was done, and the inhabitants were not disturbed enough to run outdoors. In the little settlement at El Jarro Point, the shock was so light that a small chimney with a terra-cotta top, making a height of 7 feet above the roof, did not fall; nor were similar terra-cotta chimneys on 2-story buildings thrown down, tho projecting from 3 to 4 feet. Glasses and bottles remained on the shelves in a bar-room.

At the lime-kilns (51, map No. 22) the shock had apparently been more severe, for tho no cracks were found in the kilns themselves, people ran from houses, small objects were thrown to the floor, and piles of cordwood were overturned.

(G. A. Waring.)—At the San Vicente lime-quarry, the intensity was found to have been considerably higher in the bottom of the canyon. A cow in the yard could not keep her feet, men could not walk to the door of the cook-house, and milk and water were nearly all thrown from the pans and kettles. Little or no damage was done to the buildings or furnaces, and cordwood on the steep slopes was not thrown down.

At Coast there was little sign of destruction by the earthquake, and nothing could be learned. At Bonnie Doon, tho the shock was appreciable, no clocks were reported stopt and nothing was thrown from shelves.

(B. Bryan.)—On the road thru Bonnie Doon the shock was uniformly light; chimneys were unharmed, plaster was intact, clocks did not stop, and even the milk had not spilt from the pans. People did not run outdoors. A top-heavy and rickety pigeon-house did not fall over, tho shaken considerably.

Down Laguna Creek to Coast, and up the trail east of Coja Creek to the asphalt beds, similar effects were noted. Near the latter spot, however, the shock appeared to have been somewhat stronger; small objects had fallen, milk spilt, and even one chimney was thrown down, while people were frightened enough to get out of the buildings.

From the asphalt beds as far east as the point 52, map No. 22, the observer found no one to question; but the shake had been so moderate as to leave no visible signs except where some cordwood had broken its end-stakes and rolled down at the ends. At the houses just south of this point, chimneys and plaster of 2-story structures were not damaged; only lamp-chimneys and such articles fell and broke. It was reported that at one house in the valley fruit-cans had been thrown from shelves.

(R. Collom.)—At the Wilder dairy, on the Santa Cruz-Pescadero road, 2 miles west of Santa Cruz near Meder Creek, the damage done by the shock was in the form of broken chimneys and cracked plaster in the houses. On the road 0.5 mile west of the dairy, the force of the shock broke an 8-inch water main.

A general examination of the country along the coast, as opened up by the Pescadero stage road, shows the damage in these parts to be confined mostly to broken chimneys and cracked plaster in the houses. Only in the case of buildings with very poor foundations was any of the superstructure destroyed.

(G. A. Waring.)—At Wilder's dairy it was said that the shock seemed to come southward down the gulch, preceded by a rumbling from the same direction. Other places on the terrace-land near the shore west of Santa Cruz were not so badly shaken.

*Santa Cruz* (B. Bryan).—Entering the city of Santa Cruz from the west, the first chimneys down were only about 0.5 mile from the San Lorenzo River, increasing in number as one came into the town; yet many of the better-built chimneys, even on 2-story and 3-story buildings, were not thrown down. In the eastern part of Santa Cruz, some chimneys on both 1-story and 2-story houses fell, and some stood. In some cases plaster was cracked, but in no case where enquiry was made had much fallen. Some small objects fell in every instance.

(R. Collom.)—The shock was strong, but no lives were lost. The court-house roofs and towers were wrecked, many brick chimneys were down, and communication with other towns was entirely cut off by the breaking of telephone and telegraph wires. Many buildings had their walls shaken down.

At the north end of the bridge crossing the San Lorenzo River, at Third Street, there were 4 fissures running practically parallel and almost due east and west. These fissures are about 700 yards in length, and vary in width from 2 to 8 inches. They run thru an apple orchard and are in sandy soil, the softness of the land near the river-bed being apparently responsible for their presence. The river at this place runs about east.

In going thru the town of Santa Cruz in the direction of Boulder Creek, a fissure at the intersection of Bulkhead and River Streets was noticed. This fissure was about

1.5 inches wide and ran east and west. The 90-foot brick smoke-stack of the San Lorenzo tannery, which is about 18 feet in diameter at the base, was unharmed by the shock. It is said that as far as was observed, there was no change in the appearance of the sea-level at Santa Cruz; nor was there any damage done by the sea, nor any unusually large waves at the time of the shock.

At the Southern Pacific bridge, crossing the San Lorenzo River, there is a network of fissures varying from 2 to 15 inches in width, running thru the sandy soil. The direction of the main fissures is east and west, and they are on the south side of the river, which is nearest the bay. The ground has settled about 10 inches from the abutments and piers of the bridge. The depth of the fissures was indeterminable, as they had filled with sand. At Santa Cruz the inhabitants reported that near Olive Springs, 12 miles north of Santa Cruz, a landslide demolished Loma Prieta Mill and killed 9 men.

(G. A. Waring.)—The city of Santa Cruz furnishes excellent evidence of the effect of soil formation on the intensity of the earthquake shock. On the high ground in Garfield Park, and also in the northwest part of the city, only about one-fourth of the chimneys fell and a little plastering was cracked; while in the lower ground near the business section several brick and stone buildings were partly shaken down. The San Lorenzo River was churned into foam, the banks cracking and settling several inches; and sand, said to have come from a depth of 100 feet, was forced up in several places. The bed of the river is also said to have sunk several inches, and the current to be slower than before. A 6-inch water-main, running east and west across the river, at the covered bridge, was broken at each end of the bridge and moved 5.5 inches eastward. A man out of doors, facing south, was thrown east, then in the opposite direction. A eucalyptus grove south of him swayed violently east and west.

Along the beach the shock seems to have been less severe. The running engines of the power-plant at the Casino were unaffected. Things were thrown mostly from the west wall in a curio store on the beach. The wharfinger says he heard a rumble before the shock, coming from the southeastward; and saw the seismic wave traveling shoreward, causing a great rattling and crashing when it struck the town. Two distinct periods of vibration were felt, the latter being the harder. There was very little surf, the water looking like that in a tub when jarred. A safe in the wharf office rolled 3 feet eastward against the counter, then back again hard against the wall. The wharf, extending southeast, seemed to pitch lengthwise. Mr. W. R. Springer, jeweler, reports that out of 25 clocks repaired by him, which had been injured by the shock, 20 had their pendulums thrown off.

At the Santa Cruz light-house, a noise as of a wagon crossing a bridge preceded every quake. The motion seemed vertical as well as horizontal, for the glass globe over the lamp was jarred out and broken. In the curio-store at Vue de l'Eau, nothing on the lower floor was disturbed and only a few vases and pieces of bric-à-brac on the second floor were displaced. The shock seemed to come from the south. No effect on the surf was noticed.

(R. Collom.)—Going north from Santa Cruz, a small fissure ran northwest and southeast on the Boulder Creek road, about 0.75 mile northwest of the California Powder Works. Along the lower end of this road were several small and unimportant landslides. In general, the shock in this region does not seem to have been as severe as it was farther north.

*Road into Scott Valley* (B. Bryan). — Following the road from Santa Cruz into Scott Valley, at a summer hotel the chimneys were cracked all the way down, but were still standing; light objects on the first floor were moved, and bureaus on the second floor slid a foot or so. A 1-story frame house (at 53, map No. 22) was moved 4 feet or more, and a piano and other heavy objects were shoved across the room. The damage

to the house was so serious that it was being torn down at the time of observation. A 4,000-gallon tank (at 54, map No. 22) was moved and burst open, letting out 2,000 gallons of water. At the house nearest it, the chimneys were cracked, but nothing inside had been disturbed except some bottles, and no plaster was cracked. Houses in Scott Valley had about this same amount of damage; chimneys were sometimes cracked but were still standing, and plaster did not fall.

Miss Finette Locke, of Scott Valley, reports that a man was thrown to the ground by the shock, and when he arose could not walk because of the earth's motion. The vibration was northeast-southwest. Everybody was awakened; all clocks were stopt; plastering was extensively cracked; and all chimneys were broken. About a mile north some chimneys fell, and in one house 4 dozen jars of fruit were thrown from shelves. Landslides and cracks are reported between Scott Valley and Felton, and the dam across a small lake was cracked. A statuette and a vase fell to the northeast. The largest chimney moved 2 inches to the northeast. The entire width of the road to the southwest of the small lake was splasht with water thrown out of the lake. Long billows on the lake extended northwest and southeast. In an 8-foot trough orientated east and west water was caused to sway back and forth, but not parallel to the sides of the trough. A neighbor who was awake heard a roaring noise in the northeast. Much milk and cream was thrown out of pans.

Going from Scott Valley toward the town of Felton, the shock appeared to grow constantly lighter; some people did not even get out of bed.

*Felton.* — In this village the shock was apparently lighter than at either Boulder Creek or Ben Lomond. At Zayante, some cordwood and some finer split wood, piled 8 feet high, was not shaken down, tho some of it was said to have been disturbed.

(R. Collom.)—The shock was only moderately strong. The damage consisted of the destruction of brick chimneys. Earthquake effects at this point are shown only by the damage to artificial structures.

*Pescadero to Butano Creek* (H. W. Bell). — In the town of Pescadero the shock was heavy; all but 3 brick chimneys fell, and but few buildings were otherwise damaged. Plastering was knocked from the walls in most of the houses, and church bells were rung. All the water-tanks observed were still standing, and none of the churches had lost their steeples, tho one church was cracked open. Cracks were visible in the streets. One man walking eastward along the road near Pescadero was thrown flat on his chest by the first shock, but jumped up and braced himself in this direction, and was then thrown southward. Cracks in the road also appeared, and dust spurted up. Several people were nauseated by the motion and some said that a noise as of a wind preceded the shock.

Going eastward from Pescadero, a small crack 30 feet long, with an east and west strike, was observed. In an orchard near by there were several cracks, the widest one measuring 8 inches, with a vertical displacement of 1 foot. About 2 miles east of the town, on the north bank of Pescadero Creek, a landslide in the shape of a half-moon, its axis lying N. 23° W., had slipt down toward the bed of the stream. The greatest vertical displacement at the top of the slide was 15 feet; the distance from its apex to the road about 85 feet; and the span from end to end along the road about 220 feet. No solid rock was exposed by the slide. The road had dropt 6 feet at the south end, and 8 feet at the north. Only y few cracks appeared on the surface of the part which had slipt. The creek lying directly below the road had apparently received very little soil from the landslide.

Along the stretch of road between this slide and the town of Pescadero, there were few cracks in the road and the houses were in good condition. The only brick chimney seen was down. The intensity was apparently the same as in the village, and continued

the same along the road leading southeast toward Butano Creek. A 1-inch crack at the first fork of the road a mile from the town of Pescadero extended north and south for about 50 feet, and a farm house a mile farther down the road was nearly shaken off its foundations. Dishes fell from the shelves in this house, and water oozed out of level ground near by.

(G. A. Waring.)—On Butano Creek there were slight cracks in the road, and the streams were muddy. People said the shock was felt very distinctly, and dishes generally fell. The houses were all light, low buildings, and were not damaged. At a sawmill a mile east up this creek, there was no damage; and altho the banks beside the road showed traces of caving, there were only slight cracks, the longest one being in the middle of the road above the creek, running N. 67° E. for a distance of about 50 feet.

Along the main road from Butano Creek to Little Butano Creek, then across by trail to Pigeon Point, the same effects were noticed. Near a house on the level creek bed of Little Butano Creek, 4 cracks averaging 3 inches in width and about 20 feet in length ran N. 33° E. The only crack noticed along the trail toward the coast was 1 mile northwest of the place where Little Butano Creek turns from southwest to northwest, and was about the same length, but ran N. 3° W.

*Pomponio Creek road* (F. Lane). — On the Pomponio Creek road, chimneys were shaken but not destroyed. A big slide above the last house forced the observer to leave the road and take the trail, which rejoins the road a half mile farther on.

Four miles from the town of Pescadero, on the east side of a bridge over Pescadero Creek, the ground had sunk 2 inches and the aperture filled by the land sliding. A mile nearer the town, the road had dropt 5 feet, but had been filled by a big slide. A house at this point was quite intact, but the chicken-house near it was carried down and partly buried by the landslide. On Eues Creek, near its junction with Pescadero Creek, a hillside had started to slide and apparently needed only to become rain-soaked to continue the slipping. Wherever there were buildings in this region, no damage had been done except to chimneys, which had fallen.

*The Coast from Pigeon Point to Ano Nuevo Bay* (H. W. Bell). — At Pigeon Point the brick light-house, 125 feet high, showed a slight crack all the way around inside, about 40 feet from the ground. This crack did not look dangerous. Another crack 20 feet higher up dated from December 17, 1904, the keeper explained. The base of the pedestal holding the lens was slightly cracked, but the lens was intact. In the houses near the light-house the damage was slight; brick chimneys had not fallen, tho slightly cracked, and the same was true of plastering. A mile west of the light-house a few slight cracks, with a direction of N. 28° W., were observed.

Leaving the coast road at the fork halfway between Pigeon Point and Franklin Point, and going northeast along Gazos Creek, then southerly to the crossing of Whitehouse Creek, then back again to the ocean road near Franklin Point, few traces of the shock were noticeable. A small landslip, 0.25 mile up the east side of the short creek which flows into Gazos, just west of the fork of the road which continues northwestward to Little Butano Creek, showed a 2-foot vertical displacement at the top, and the land had shoved into the road below. This slide measured 150 feet from its top to the road, and its width at the road was 100 feet.

Along this route from Gazos to Whitehouse Creek, 0.125 mile from Whitehouse Creek, at several farm houses brick chimneys were down, houses slightly moved on their foundations, dishes broken, and plastering cracked. A half mile northeast of the mouth of Whitehouse Creek the same kind of disturbance was found. The intensity was apparently uniform with that at Pescadero. At the Cascade ranch, 0.25 mile northwest of Green-oaks Creek, the shock was oven stronger than on Whitehouse Creek. Cows were thrown off their feet, chimneys were down, the house cracked, and nearly all plastering fell off.

(H. W. Bell.)—It was reported here that along the Ocean Shore construction work near Bolsa Point, a concrete pipe 24 inches in diameter and 6 inches thick, embedded in clay, had been cracked by the shock. The keeper of the Ano Nuevo light-house says a distinct rumbling preceded the shock, which came at first rather gently, followed by a hard, confusing shake. A brick chimney in the house near by was cracked and twisted 0.75 inch out of place, but the new tile and concrete building was unhurt. The ocean became no rougher, but had a peculiar greenish hue for several days after the shock. At Pigeon Point the shock was less severe, and little damage was done to the buildings, altho cracks in the light-house, caused by a former quake, were opened somewhat wider.

Following the road from the Cascade Ranch across toward Ano Nuevo Bay, the intensity seems to have decreased. At a house 0.75 mile southeast of where the coast road crosses Greenoaks Creek, a few dishes fell; plastering was but slightly cracked, and a water-tank stood. Half a mile north of the mouth of Ano Nuevo Creek, the brick chimney was knocked from a house, plaster was cracked, and cattle were caused to stagger. Half a mile southeast of where the main road crosses Finney Creek, a ledge of shale had been knocked into the gulch. The largest piece which fell had an unbroken surface of about 4 square feet. The almost horizontal edges of shale beds near a house at this point were knocked down. A long, narrow landslide above a house 0.75 mile northeast of the mouth of Waddell Creek had landed against the end of the house, taking out a strip of earth below a spring and causing a good supply of water to issue forth. This slide appeared to be partly due to the large amount of water present. At the house the chimney was cracked, but dishes did not fall from their places.

Turning north by a trail opposite Greyhound Rock, evidences of about the same intensity were found. Dead trees had fallen here and there, but in no uniform direction.

#### LOS GATOS TO SAN JUAN.

*Los Gatos, Santa Clara County* (I. H. Snyder).—Los Gatos, population 1,900, is partly on a mountain slope and foot-hills, and partly on river deposit. It is surrounded by hills on three sides. Los Gatos Creek runs thru the center of the town from south to north. The earthquake shock was violent, but apparently not so severe as in the central portion of the valley. Nearly all business houses were damaged, and about one-third of the plate glass fronts were broken. Much plaster fell both in Los Gatos and in the surrounding country. Chimneys fell in many different directions, and nearly half of the damaged chimneys left standing were twisted. About 80 per cent of all the chimneys were destroyed or damaged. Brick fronts were nearly all cracked, and one fell out. There were about a dozen upheavals of sidewalks, mostly on north and south streets. Grocers and druggists lost quite heavily in breakable goods.

The direction of the shock seemed to be in general north and south, altho there were certainly severe vibrations from nearly all points of the compass, while some persons are certain that there was a vertical motion, especially near the beginning. After the shock was over, our chandelier was still swinging violently north and south; a near neighbor's lamp swung in the same way; another hanging lamp 0.5 mile west swung northeast and southwest. East and west shelving in stores suffered rather the most, tho a store in East Los Gatos, with shelves north and south, suffered fully as much as any.

Of the 3 pianos seen in Los Gatos that were moved, 2 went to the south about 3 feet and one moved east the same distance. A small seismograph made several years ago was in working order, but there was no record, the needle having been thrown off by the extreme movement.

Mr. Lund, of Los Gatos, was one of the few people outside when the shock came. He is positive the premonitory roar came from the south and traveled to the north.



Mr. Dan Pickering, living about a mile south of Santa Clara, on the Santa Clara and Los Gatos road, was standing outside his barn when he heard the sound, which he compares to a stampede of cattle coming from the southeast. His tank and wind-mill fell diagonally across the foundation to the northwest, after swaying heavily three times; first to the northwest, then to the southeast, and finally to the northwest. He states that the ground rose and fell in waves a foot high. Others report that the orchards seemed to be agitated by a wave-like motion.

On the ranch of Dr. Tevis, about a mile from Alma Station, where the land is rolling and wooded, the ground was fissured and the bottom of an artificial lake was upheaved. (Plate 139c, D.) The cracks and fissures, of which there are many, run mostly north and south, and vary in length up to 100 feet, and in width from 0.5 inch or less to 20 inches. While a good many of the openings were parallel to the slopes and were caused by the ground starting to slide, others crost the roads and could be traced some distance up the banks. A board fence was splintered where it crost a fissure. The upheaval of the lake was caused by a closing together of the sides, shown by the heaving up of parts of the retaining dam at the lower end of the lake. The rise of the bottom is roughly 10 feet.

Three of the large cemeteries of the Santa Clara Valley were visited. In the Los Gatos Cemetery, on the New Almaden road, no monuments were thrown. In the Protestant Cemetery, 0.75 mile southwest of Santa Clara, 31 monuments were thrown down and mostly broken. Of these 10 fell to the south. In the Catholic Cemetery, 0.25 mile nearer Santa Clara, 26 monuments fell, of which 10 fell to the south. The direction of the fall of monuments in these two cemeteries is here tabulated:

	N.	NE.	E.	SE.	S.	SW.	W.	NW.	Total
Protestant . . .	3		7 <sup>1</sup>	1	10	1	5	4	31
Catholic . . .	5	1	6	2	10	1	1		26

<sup>1</sup> Of these, 4 fell from pedestals which leaned to the east.

In the Catholic Cemetery three monuments were turned on their bases, two clockwise and one counter-clockwise.

The Santa Clara city water-tower, with large tanks on top, fell to the southwest.

(F. H. McCullogh.)—I was in bed in Los Gatos and was awakened by the shock, which seemed to be a violent but irregular shaking back and forth in a northeast-southwest direction, altho objects were overturned in an easterly or southeasterly direction. A double bed on a polished floor rolled 4 feet from its position. One heavy marble clock was thrown off its shelf. Ornaments and bric-a-brac were thrown down. Two tables were turned upside down. Plastering was cracked. Chimneys were cracked above roof, but not thrown. In the town I could hear of only one chimney which was uninjured; 90 per cent of all chimneys were thrown down. Water in a reservoir 30 feet in diameter and 10 feet deep was thrown out so as to lower the level of the water nearly 2 feet.

*Lexington* (H. R. Johnson).—At the Lexington saloon, 3 miles south of Los Gatos, very little damage was done.

At the Averill place, 1.5 miles west of Wright's Station, a water-tank was moved a foot toward the south. A piece of board several feet long, which was leaning against the tank-house before the shock, was said to have been found wedged between the bottom of the tank-house and the foundation. This would necessitate a lifting of the tank-house in a vertical direction on that side, which might have been accomplished by the tank-house rocking from side to side.

*Summit Hotel* (H. R. Johnson).—At Summit, a summer resort, the new hotel and several small cottages were all thrown toward the north. The main fault fracture is

about 500 feet northeast of the hotel, and a secondary crack close to it had a downthrow of from 5 to 7 feet on the north or downhill side. The crack was about 4 feet wide here, and the line of fracture was parallel with the direction of the ridge. The Summit school-house was dropt 4 feet downhill from its original position toward the northeast. In the vicinity of Summit several redwood trees were snapped off.

Just north of Wright's Station, on the west bank of Los Gatos Creek, there was a landslide 0.5 mile wide which had slid into the creek and dammed it. \* The top of this slide was near the Summit school-house and was close to the main fault-line. The Hotel de Redwood was destroyed by the shock.

*Wright Station* (Miss F. C. Beecher). — Miss Beecher's home is on Loma Prieta Avenue, on the county line, 1.5 miles in an air-line from Wright's Station. The house stands on a ridge at an elevation of 1,700 feet. There were 2 maxima in the shock, of about equal intensity. The movement in the first was from south-southwest to north-northeast. All light objects were thrown down. Furniture against south walls was thrown down or moved out; objects against other walls were not moved as much. A small square piano which stood a few inches from a northeast wall ran back against the wall to the north with sufficient violence to break a knob off one leg. It then moved back to its original position, then 5 inches west. Then the two legs to the north jumped 6 inches south. These movements were determined by the marks upon the floor. A wash-basin, and a pitcher full of water, in an upstairs room, were thrown south, and the basin was found with the pitcher standing in it, uninjured but empty. A table in the middle of the same room fell to the north. A piano in a neighboring house, a heavy upright, was moved across the room to the northeast.

All brick chimneys on the ridge fell, mostly to the north. Trees at the foot of the ridge were bent over to the north-northeast. Half a mile to the northwest of the house, a fissure 2 feet wide appeared, from which bad-smelling gas emanated. The fissure runs from north to south, and the earth was piled up on the west side from 2 to 4 feet high across the road. On Highland, a mile to the west, a fissure 5 feet wide was opened at an altitude of 2,500 feet. A building standing close to a fissure was entirely uninjured, while others a little farther off were wrecked and one collapsed. Most good buildings in a belt 0.5 mile west of the house were wrecked, while barns and shaky buildings stood. About 1.5 miles west, a house split open. Gulches appear to have been contracted, as the bridges crossing them show that they were squeezed. The banks of Burrell Creek appear to have approached each other, so that the creek has become very much narrowed. Water-pipes were broken and twisted, and filled with dirt. Water was thrown out of tanks, but the tanks were not overthrown.

During the shock the waves appeared to oscillate in a north and south direction at first. There were at least 26 shocks during the first 26 hours after the main shock.

*Burrell School* (H. R. Johnson). — Near the Burrell school-house, 1.5 miles southeast of Wright Station, a crack extends across the road by a blacksmith shop and shows a downthrow of 4 feet on the northeast. The blacksmith said there was a strong odor of sulfur for 5 or 10 minutes after the shock. A well near by has had sulfur in the water for a number of years.

*Morrell Ranch* (H. R. Johnson). — The Morrell ranch is located 1 mile south of Wright's Station and is on the line of the fault. The house itself was built exactly upon a fissure, which opened up under the house at the time of the earthquake. The house was completely wrecked, being torn in two pieces and thrown from its foundation. (Plate 107B.) There was an apparent downthrow upon the northeast side of the fault, as seen in the orchard; but under the house the vertical movement was not so apparent. An especially strongly constructed wine cellar built into the side hill had the upper portion thrown 3 feet northeast, directly away from the fault-line. After the shock this upper portion



A. Shortening of railroad track between Los Gatos and Santa Cruz. Oh Ai Wi



B. The MorwU house, near Wright Button. & A.W.

of the house was left resting upon the wine tuns, and not upon its original upright supports (fig. 56). The fence and road near the house were crost by the fault and showed an offset which indicated a relative movement of the southwest side toward the southeast (plate 64B). One fence was broken apart, but the other was merely bowed, due probably to the resistance and drag of soil occasioned by a well-packed roadbed. The fruit-tree rows which crost the fault-line at approximate right angles were put out of alinement.

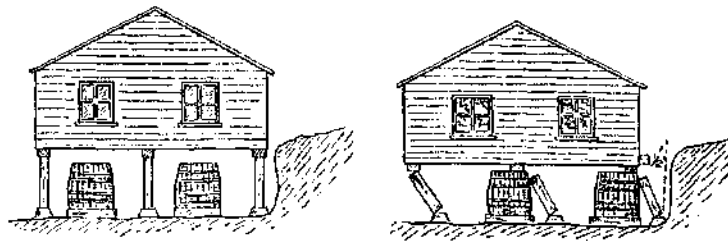
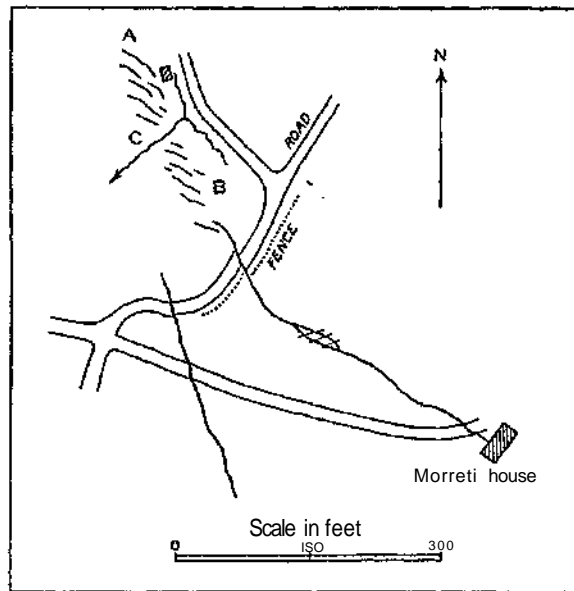

FIG. 56. — Section thru winery at Morrell ranch before and after the shock.

A feature associated with the movement of soil along the fault-line is shown in the accompanying sketch, fig. 57. The "splintering" of the main fracture raised a long, low ridge across which a creek had been forced to cut its way thru a vertical distance of 1.5 feet to get down to its original level.

Between Wright's and Alma the railway track was buckled. (See plate 107A.)

(D. S. Jordan.)—At Morrell's ranch, about 4 miles above Wright's, a large 2-story house with a wing stood on the slope of a hill. The east side of the house was much higher above the ground than the west, and stood on wooden piers about 7 feet high. The earthquake crack past thru this ranch, a branch of it going under the house. The main body of the house was thrown to the east, away from the crack, the ground there slumping several feet and the house being almost totally wrecked. All thru the orchard the rows of trees are shifted about 6 feet, those on the east side being farther north, and the east side, which is downhill, seems to have fallen. The crack is largely open and in one place is filled with water. This should be attributed to slumping. A little farther on, the crack passes thru a grassy hill on which there is no slumping. The Morrells say that this hill has been raised. What appears to be the fact is that the east side of the hill overrides the other. The whole top of the hill is more or less cracked for a width of about 10 feet. The east side is a little higher than the west side, and it looks as tho the hill had been shoved together and raised, the east side overriding. About 1 mile beyond Morrell's house, at the end of the ranch, there is a blacksmith shop, and the road is crost by the crack. Here there is a break of 3 or 4 feet like a waterfall, the east side being the lower; but this is part, I take it, of the general slumping of the east side of the crack



From S. L. — DLsplacement on auxiliary crack, Morrell ranch.

where it stands near the ravine above Wright. Morrell's place is right over the Wright tunnel, the tunnel and the rocks near by being of finely broken rock and very much subject to slides and other breaks. At Freely's place, 4 or 5 miles north of Morrell's, some 15 acres of woodland have slid into Los Gatos Creek, making a large pond. There are many other slides in the neighborhood and many broken trees. Farther on, the crack goes into Hinkley's Gulch, in which the Loma Prieta Mills are situated, and which are buried under the slides. The slides which obliterated Fern Gulch at Skyland do not seem to have come from the crack, but seem to lie to the west of the crack.

*About four miles, south of Wright Station* (Mr. L. E. Davidson). — I was camping in the Santa Cruz Mountains. My attention was first arrested by a slight rumbling noise; then the house trembled for 4 or 5 seconds, and this was followed by a heavy rolling motion almost east and west. A heavy trembling came again for several seconds, then the heavy shock that threw down the chimneys. Tables and even chairs were upset. This must have lasted about 4 seconds; it then gradually died away. The whole time must have been all of half a minute. During the day several slight shocks were felt; about 2<sup>h</sup> and 2<sup>h</sup> 30<sup>m</sup> P. M., two rather heavy shocks came.

The ridge on which we camped was full of cracks, ranging up to 2 and 3 feet in width, and in length from a few rods to 0.25 mile, all trending west of north to northwest. All chimneys on this ridge were thrown down; several houses were completely wrecked; branches were broken from the trees, while many of the trees broke in two and others were uprooted. The canyon south of us was filled with landslides. In this canyon the stratification of the rocks is plainly shown. The strike is northwest-southeast and the dip is almost vertical. The cracks coincide in direction with the strike of the strata. Cold water was flowing from some of the cracks. I obtained a small bottle of crude oil from Mr. Sutton, which he said was dipt up from the ground on his neighbor's ranch, several hundred gallons of oil having run out of the ground since the earthquake, where there had been no sign of oil before.

*Skyland, Santa Cruz County* (T. Wightman). — Mr. Wightman's bed traveled across the room to the south, and he was under the impression that the house was falling to the south. Some houses in the neighborhood fell completely, and some collapsed on their foundations. The two chimneys of his house were thrown, one coming through the roof. Some pictures hanging on east walls were turned with their faces to the wall. Large landslides occurred in the neighborhood.

*Soquel, Santa Cruz County* (Miss M. E. Baker). — The house is on the first high bench above the stream in Soquel Valley, with high hills to the north and the east. At the first movement of the earthquake, chimneys were thrown to the south; at the second, mantel ornaments, books in the library, fruit jars in the pantry, etc., were thrown toward the north. Some houses in the vicinity had chimneys and objects partly turned around. There were two maxima in the shock, the first being the stronger, and the direction of movement was from north to south. In the second part of the shock the movement seemed to be a twisting one.

*Chittenden* (G. A. Waring). — At Chittenden Station evidence of a most violent disturbance was found. The cottage of the foreman was moved 5 inches westward; an upright piano was thrown northwestward upon its back, and electric drop-lights swung so as to break against the ceiling. A large frame dairy building on underpinning was moved 1/2 feet northward, as was a smaller building. The oil in a large tank was thrown southeastward, badly bending the tank and smashing the protecting shed. (See fig. 58.) The railroad office was not moved from its foundations, but the porch roof was jerked nearly off and a 1,000-pound safe was thrown southeastward upon its back. Three freight cars on the side-track, loaded with beans, were tipped over to the northeastward. At the time of the shock a north-bound freight train was running at

about 30 miles an hour, a short distance south of the bridge over the Pajaro. About 10 cars in the middle of the train were thrown off on both sides of the track. The track at the southern end of the Pajaro bridge sank from 2 to 4 feet for a distance of 150 yards, and between Chittenden and the bridge the track was bent in an S-shaped curve in several places. The concrete piers of the bridge were cracked, and the granite cappings shifted as before noticed. (See plate 65B and fig. 43.) There is much sulfur, oil, gas, and water in the hills here. A marked increase was noted in the flow of oil and water, and more gas and sulfur became associated with them. It is said that since the earthquake 16 years ago small shocks have been felt each spring, often severe enough to crack chimneys, and a deep well becomes muddy 2 or 3 days before these occur.

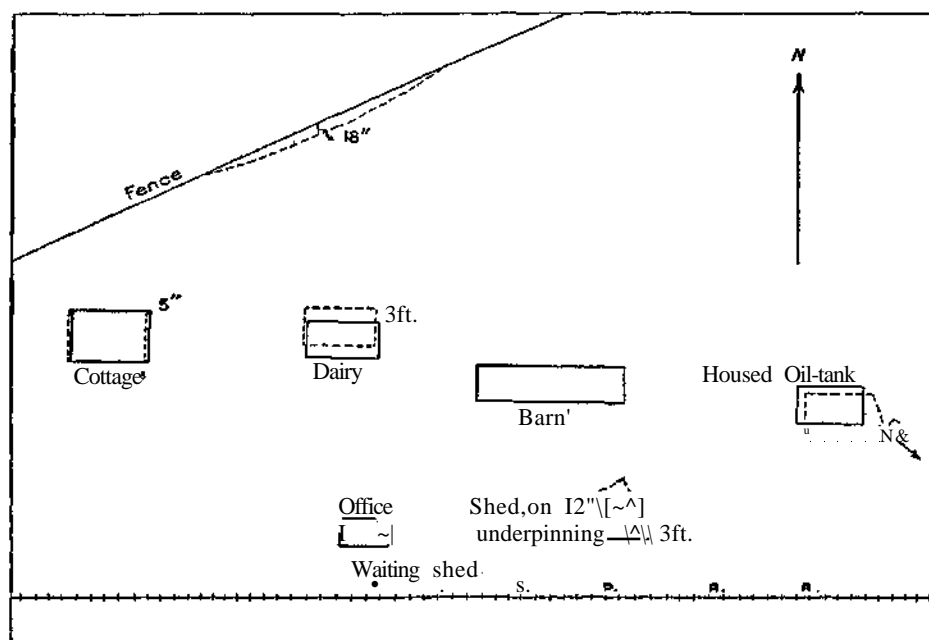

FIG. 48—Displacement of buildings at Chittenden

Fifty-two distinct shocks were felt during the day of April 18, and 32 that night. From 1 to 4 shocks were felt every day thereafter up to May 16, and from 2 to 5 occurred every night. Two miles north of San Juan, Mr. Canfield's house, at the foot of the hills 0.5 mile east of the fault, was moved bodily 2 inches westward, and the chimneys were completely thrown down; but a house 150 yards west of the fault, altho considerably shaken, appears to show the shock to have been less severe on that side.

*San Juan* (G. A. Waring).—The town largely escaped by virtue of being on solid ground. A large inner wall at the San Juan Mission fell, but it was no doubt weak, as other parts of the building appear unhurt. Only one or two chimneys in this village fell, but in the bottom-land between San Juan and Hollister the condition of the houses indicates a heavier shock on the low ground.

#### SANTA CLARA VALLEY.

Information regarding the distribution of intensity in Santa Clara Valley has been contributed by a number of observers whose names are given with the paragraphs dealing with the respective localities reported upon by them.

*Newark* (F. E. Matthes).—Nearly all brick and tile chimneys in the village were broken off; the direction of throw varied. Plaster cracked and fell in quantities on the lower floors of hotels and several other buildings. There are no brick houses in the town; and most of the frame dwellings showed no effects of the shock. At the depot the

water-tank fell, the supporting trestle being practically demolished. The track suffered a slight shifting in several places north of the village. Cracks opened in the ground in the vicinity of 2 small watercourses, but on a less extensive scale than that noted at Alvarado. Some of them cross the railroad track. In every case they emitted the same bluish sand (with the water) that had been found near the Alameda Sugar Mill. In one place, 1.5 miles northeast of the village, considerable water was still left standing in shallow ponds. According to neighboring ranchmen, these ponds had not existed prior to the earthquake.

*Centerville* (F. E. Matthes).—The amount of destruction here seems greater than in the neighboring towns, but this is in large measure due to the presence of a number of poorly constructed brick houses. All of these had suffered severely, the walls being in part thrown down. The bank building was more seriously damaged than most buildings, the walls being partly demolished and the roof having caved in. With very few exceptions all the brick and tile chimneys were broken off. Window panes broke in several stores. No cracks in the ground were found or reported. The direction of the shock was not agreed upon by the residents; according to some it was north-south, according to others east-west.

*Mission San Jose* (S. Ehrman).—Nearly all chimneys were thrown down, and plaster in houses cracked; the direction of the throw of chimneys and objects being chiefly from north to south. Some objects were rotated clockwise, and hanging objects were caused to swing.

*Irvington* (F. E. Matthes).—Destruction similar in degree to that at Centerville. Every brick house was more or less extensively damaged; portions of walls fell in some instances, and cracks in brickwork were common to all. The large brick and stone buildings of the Palmdale Winery suffered more severely than any, and large portions of them will have to be rebuilt entirely. Only a few chimneys were left standing in the village. Plaster cracked and fell in large flakes in several houses. The upper stories apparently suffered less than the lower floors.

*Milpitas* (F. E. Matthes).—Nearly all chimneys were here thrown down, a few, including a very short one on the depot, being left intact. There are no brick buildings in the village and the destruction seems insignificant. The hotel slept on its foundations, but was almost repaired at the time of the visit. A small adobe house in the southern part of the village was fairly demolished; it was known to be an old and weak structure. A water-tank and wind-mill were thrown down, support and all, about a mile south of town. They fell to the south. Another tank, north of town, appears to have fallen to the west. Several other tanks in this neighborhood were found intact. Of the two bridges over Coyote Creek, the northern one suffered some damage by displacement of end supports. It was unsafe to travel over at the time of the visit. The southern bridge was found intact, the end supports showing signs of but small movement.

*Agnews* (F. E. Matthes).—The insane asylum, consisting of three tall and three minor brick buildings and some small frame structures, suffered very severely. Every one of the brick structures was damaged beyond repair and will have to be entirely rebuilt. The main buildings were long, 3-story brick structures oriented north and south, with large projecting bay windows at their north and south ends. These were destroyed, so that both buildings are open at their ends. The fall of these walls caused the caving in of the roof, and the sagging down in some places of the floors. Numerous lives were lost; in all 112 dead being found in the ruins. The administration building was partly wrecked by the fall of its tower, which crashed thru the roof and all the floors, carrying with it a number of people. In nearly all cases the north and south facing walls were thrown out, while the east and west facing walls were, as a rule, better preserved. The shock seems to have been north-south principally, judging from these data.

The tall brick chimney of the engine house (100 feet high) broke off 20 feet above the ground and fell in a northeasterly direction, without touching any other structure. Frequently window-panes remained unbroken in the lower parts of walls whose upper parts had been completely demolished. (See plate 108A, B.)

The extent of the destruction is in some measure due to the use of weak mortar, the bricks having, as a rule, fallen separately rather than in aggregates. It is believed that well-built buildings would not have suffered such wholesale destruction as was witnessed here.

*Alviso to Milpitas* (G. F. Zoffman).—Evidences of the earthquake at Alviso are shown only by fallen chimneys and cornices and by cracked walls of the brick warehouses. No buildings were demolished and little serious damage of any kind was to be noted. From 1,500 to 2,000 feet west of the bridge over Coyote Creek, cracks cross the road in front of the Boot ranch-house, and several of them occur in the road leading to that house. (Plate 140B.) Some of these cracks are about 6 inches wide and have a general bearing of N. 43° W. Immediately after the earthquake, water flowed from some of them and brought up sand, which was heaped up about 6 inches high. The water ceased to flow after the second day.

Near the dwelling house on the Boot place, the ground settled 11 inches on the east side of the crack. The fissures past under the corner of the dwelling house and the building was partly thrown from its foundation. The cellar beneath it was filled with water to a depth of from 2 to 3 feet. There is a capped artesian well in the yard of this house, and about this well is a pool of water 12 feet across. The west side of the pool was lifted 1 foot higher than the east side, and fish were thrown out of the pool. A hundred feet east the fissures past under the barn, and the ground settled on the west side. Water flowed from cracks in the yard and piled up sand 6 inches high on both sides.

People living near Coyote Creek state that the water rose between 2 and 3 feet immediately after the earthquake; and up to April 26 the water in this stream had not returned to its normal level. At the bridge over Coyote Creek, on the Alviso-Milpitas road, the concrete abutments were thrust inward toward each other about 3 feet. A pile driven in the middle of the stream, which had been cut off below the water-level, was lifted about 2 feet and now rises above the water.

About 150 feet north of this bridge the banks of the stream cracked, the fissures running parallel with the channel and the land on the creek side sliding toward the stream. (Plate 140A.) West of the stream, in an adjoining field, water rising thru cracks built up many craterlets of sand. (Plate 143A.) Residents of the vicinity state that the water rose 3 or 4 inches above the tops of these craterlets while they were being formed, and that it ceased to flow toward the end of the second day after the earthquake.

In the road running northward along the west side of Coyote Creek from the bridge, many large cracks opened. Five hundred feet north of the bridge the cracks were 2.5 feet wide and 3 feet deep when the place was visited April 26. Farther north the cracks were very abundant, mostly parallel with the road, and some were 4 feet deep and 3 feet wide. A quarter of a mile north of the bridge, the whole road was shoved eastward into the channel of the creek, and with it a large number of willows and cottonwood trees that grew along the banks. Just south of this place the road was broken up badly for a distance of 300 feet. One of the largest cracks in the road was 5 feet wide, 6 feet deep, and more than 100 feet in length. The bearing of the fissures at this place was N. 23° W. For the most part the principal features were approximately parallel with Coyote Creek.

At Mrs. North Whitcomb's ranch, on the south side of the Alviso-Milpitas road, between Coyote Creek and Milpitas, the prune orchard was cracked and the ground shifted



at several places. The ranch-house, of concrete with a wooden upper story, was cracked across the northwest corner and settled slightly on the northwest side. In the back yard were fissures 1 foot wide, running about N. 13° W., with a downthrow of 1 foot on the east side. Some of the prune trees in the orchard are 2 feet out of alinement, and some as much as 6 feet. The lateral displacement here shows a relative movement of the south side toward the east. Considerable sand was brought up by water flowing from the cracks in this orchard.

In the town of Milpitas all the chimneys were thrown down, as well as 3 frame buildings. The hotel fell from its underpinning and sank bodily about 3 feet. The streets near it were not disturbed.

*Warm Springs* (G. F. Zoffman).—The Warm Springs Hotel, a large 2-story building, was but slightly damaged, only a little plaster falling. No buildings were damaged, beyond the falling of two chimneys.

*Milpitas-San Jose Road* (G. F. Zoffman).—About 0.5 mile south of Milpitas, on the Milpitas-San Jose road, cracks were formed across the road. They did not, however, appear to have any definite direction, and were so small that no lateral movement was discernible. At the County Alms House, about 1 mile south of Milpitas, two chimneys were thrown down and considerable plaster fell. On the north side of the bridge which crosses Coyote River, on the San Jose-Milpitas road, some cracks were found but they were evidently caused by the sliding of the banks. The bridge was not damaged.

The damage in the section of country lying between Milpitas and San Jose was nearly uniform. About 90 per cent of the chimneys were thrown down and in all houses that were plastered considerable plaster fell. Articles in the houses were thrown over, and much water and milk was spilt, altho it does not appear to have been in any particular direction. Cracks like those which were observed in the ground on the Milpitas-Alviso road reappeared on both sides of the Coyote River at intervals all the way to San Jose. Altho they occur in a general north-south direction, it seems probable that their origin was due to the unstable condition of the alluvial deposits which underlie the valley.

*Alum Rock Road* (G. F. Zoffman).—Starting from San Jose and going toward Alum Rock, it was observed that the shock had decreased from an intensity of IX at San Jose to an intensity of VI at Alum Rock. No cracks were found between Coyote Creek and the mountains, but in the valley at least 90 per cent of the chimneys were thrown. At the mouth of the Alum Rock canyon, a count of the fallen chimneys revealed the fact that the percentage had dropt to 50. At Alum Rock no chimneys were damaged nor had any movable objects been overturned, altho the water in sulfur baths had splasht up about a foot on both sides.

*Calaveras Valley to Evergreen and vicinity* (G. F. Zoffman).—Going from Milpitas toward the Calaveras Valley, chimneys were all thrown down on the flat lands between the village and the foot of the grade leading over the ridge to Calaveras Valley.

In Calaveras Valley all the brick chimneys were thrown down, tho there were only a few in this valley. No damage to houses is reported. Mr. Hadsell, in charge of the property of the Spring Valley Water Company, which has begun to construct a dam at the north end of the valley, states that there was no shifting of the strata in the tunnels, and that no damage had been done the property.

Between this place and the head of Alum Rock Canyon, the residents stated that cracks appeared across the road in several places; but altho this was in the proximity of the Calaveras Valley fault-line, which passes thru this region, it was not possible to verify their statements. Mr. Robert Ingleson, who lives in section 22, on the ridge east of Calaveras Valley, reports that the shock was not severe there. A long slender bottle standing on a table in his house fell over, but a lamp on the table was not upset.



A. Agnew's Insane Asylum, North end of female wards. P. E. M.



C. Phelan Building, San Jose.



B. Agnew's Insane Asylum, North side. F. E. M.



D. Hailef Records, San Jose.



A. High-school, San Jose.



B. Hotel Temdbme, Aasex. Saa *J&m*>

Water in a horse-trough spilt out, and the trees waved as if there had been a wind. The earthquake consisted of two separate shocks, accompanied by a roaring sound that seemed to come from the north. Springs near his house became muddy after the shock and remained so for 2 or 3 days. The flow of the springs increased to about four times the usual amount.

Along the road down Penetencia Creek, a considerable amount of debris had slid into the road, in many places obstructing all travel except for pedestrians; but no evidence of cracks could be found.

In the region between Alum Rock and Evergreen, about 50 per cent of the chimneys were thrown down, but none of the buildings were materially damaged.

As the Santa Clara Valley was once more approached, the intensity of the shock perceptibly increased. At Evergreen, about 1.5 miles from the foot-hills, considerable damage was done; all the chimneys, all the road tanks, and nearly all of the wind-mills in the neighborhood fell. None of the houses were demolished, but some were shifted on their foundations.

(H. R. Johnson.)—The Pierce ranch-house, 3 miles southeast of Evergreen, was badly shaken; plaster and chimneys were down and much chinaware was broken. This house is on the gravel of the large alluvial cones which have been built out along the southwest face of the Monument Peak Range, where the stream debouches upon the plain. A water-tank fell northeast and southwest where the Tully road crosses the Coyote River 1.5 miles northeast of Oak Hill Cemetery.

At the Mayne ranch, 3 miles south of Oak Hill Cemetery, where the New Almaden Railroad crosses the Downer road, water from tanks and troughs was spilt in a north-west and southeast direction. To the west of the Mayne ranch, at the Downer ranch, a water-tank fell to the west. Mr. Downer said that milk in pans was spilt in the same direction.

At the Poncelet ranch-house, on Llagas Creek, 7 miles southwest of Madrone Station, only one chimney fell and no dishes were broken and no clocks stopt. This place is only 3.5 miles northeast of the fault-line and is situated directly upon rocks of the Franciscan series.

The Saunders ranch is 3.5 miles southwest of Madrone, on the Madrone road. The shock was quite heavy at this place; the chimneys were thrown down, dishes broken, and portions of what appeared to be quite solid and massive rock outcrops were thrown from the steep hills near the house. South of the Saunders place, 1.5 miles, a water-tank was thrown down.

*Santa Clara* (G. F. Zoffman).—Nearly all the brick chimneys were thrown down and most of the brick buildings were damaged. At Santa Clara College the rotary motion of objects was shown by the turning of statues in the chapel thru an angle of  $130^{\circ}$ . In the library of the same institution four marble statues, with square bases, fell in three different directions; one facing S.  $87^{\circ}$  W., another facing N.  $87^{\circ}$  E., fell toward each other, while the others, facing, respectively, N.  $3^{\circ}$  W., S.  $3^{\circ}$  E., fell N.  $3^{\circ}$  W. Professor Ricard, of the Science Department of the College, states that the vertical movement threw a wind-gage out of a socket a foot deep. This was the only evidence at the College of vertical motion.

*Cemeteries* (G. F. Zoffman). — A count was made of the number of tombstones thrown down in the Santa Clara Cemetery and the various directions in which they fell were noted. From these observations it seems that the shock was slightly more intense toward the easterly direction than toward the westerly. Twenty-five headstones were down and their respective directions of falling were, 3 N.  $17^{\circ}$  E.; 1 N.  $32^{\circ}$  E.; 1 N.  $37^{\circ}$  E.; 2 N.  $62^{\circ}$  E.; 1 N.  $77^{\circ}$  E.; 1 E.  $17^{\circ}$  S.; 1 S.  $58^{\circ}$  E.; 6 S.  $28^{\circ}$  E.; 3 S.  $23^{\circ}$  K; 1 S.  $3^{\circ}$  K; 1 S.  $37^{\circ}$  W.; 1 S.  $42^{\circ}$  W.; 1 N.  $88^{\circ}$  W.; 1 N.  $73^{\circ}$  W.; and 1 N.  $13^{\circ}$  W.

At Oak Hill Cemetery the larger percentage of tombstones fell in an easterly direction. Out of 34 monuments overthrown, 21 fell toward the east or nearly so; 6 toward the west or nearly so; and 1 toward the north or nearly so; 3 fell northeast, one fell northwest, 1 fell southeast, and 1 fell southwest. Out of 6 round monuments that were noted, 4 fell toward the east, 1 northwest, and 1 north. Since these could fall in one direction as quickly as another, it is evident that the greatest movement of the quake must have been toward the east at this particular place.

At the Catholic Cemetery, about halfway between San Jose and Alum Rock, only a few monuments were overturned; they fell as follows: 2 north, 3 south, 1 northwest, 2 east, 1 west, 1 southeast.

*San Jose* (G. F. Zoffman).—The earthquake threw down many brick and stone buildings (plates 108c, D, 109A, 110B, 111, 112, 113), and with the exception of 4 or 5, damaged all the rest of the brick buildings, more or less. (Plate 110A.) The damage done to frame houses was proportionately far less. Forty buildings were counted, however, that were thrown off their foundations and damaged to a greater or less extent. In many instances these buildings were completely demolished. (Plate 109B.) Numerous wind-mills and tanks capsized, while at least 95 per cent of the brick chimneys thruout the town fell. Movable objects, such as pianos, were in most cases wheeled out into the room, but there did not appear to be any general direction in their displacement. Water and mud in many instances are reported as having spurted from the artesian wells, but in a few days they resumed their normal condition. The plate-glass windows on the south side of First Street were cracked much more than those on the north side. This phenomenon was not noticeable on the other streets.

Data were obtained of the directions in which the chimneys fell thruout the town. After the data were collected and tabulated as shown below, it became evident that chimneys usually fell with the slant of the roofs.

In order to group the directions in which chimneys fell, the circle was divided into 8 sectors, of 45 degrees each, starting from the bearing of First Street, namely N. 30° W. The general directions of these sectors are: N. 15° E.; S. 15° W.; S. 75° E.; N. 75° W.; N. 60° E.; N. 30° W.; S. 30° E.; and S. 60° W. Then the direction of the falling of a chimney was taken according to the sector toward which it fell. The streets in the main part of town run either parallel or at right angles to First Street. Since the bearing to First Street is N. 30° W., that of Santa Clara Street (at right angles to First) is N. 60° E. Generally the slant of the roofs of the houses that face these two streets will be N. 30° W., S. 30° E., N. 60° E., and S. 60° W., respectively. It was in these four general directions that the greatest number of chimneys were thrown over. The eight general directions are as shown on the following table :

*Directions of throw of chimneys.*

Directions.	On streets parallel or approximately parallel to Santa Clara Street, and percentages of total number down on these streets whose bearing is N. 60° E.		On streets parallel or approximately parallel to First Street, and whose bearings are N. 30° 39' 45" W.		Total number of chimneys counted in San Jose and their directions of falling.	
	Out of 710 chimneys.	Percentage.	Out of 2000 chimneys.	Percentage.	Out of 2710 chimneys.	Percentage.
N. 15° E. . . .	52	7.3	222	11.1	274	10.1
S. 15° W. . . .	43	6.1	184	9.2	227	8.4
S. 75° E. . . .	87	12.3	225	11.3	312	11.5
N. 75° W. . . .	69	9.7	248	12.4	317	11.7
N. (10° E. . . .	178	25.1	239	11.9	417	15.4
N. 30° W. . . .	58	8.2	362	18.1	420	15.5
S. 30° E. . . .	82	11.5	348	17.4	430	15.1
S. 60° W. . . .	141	19.8	172	8.6	313	11.5

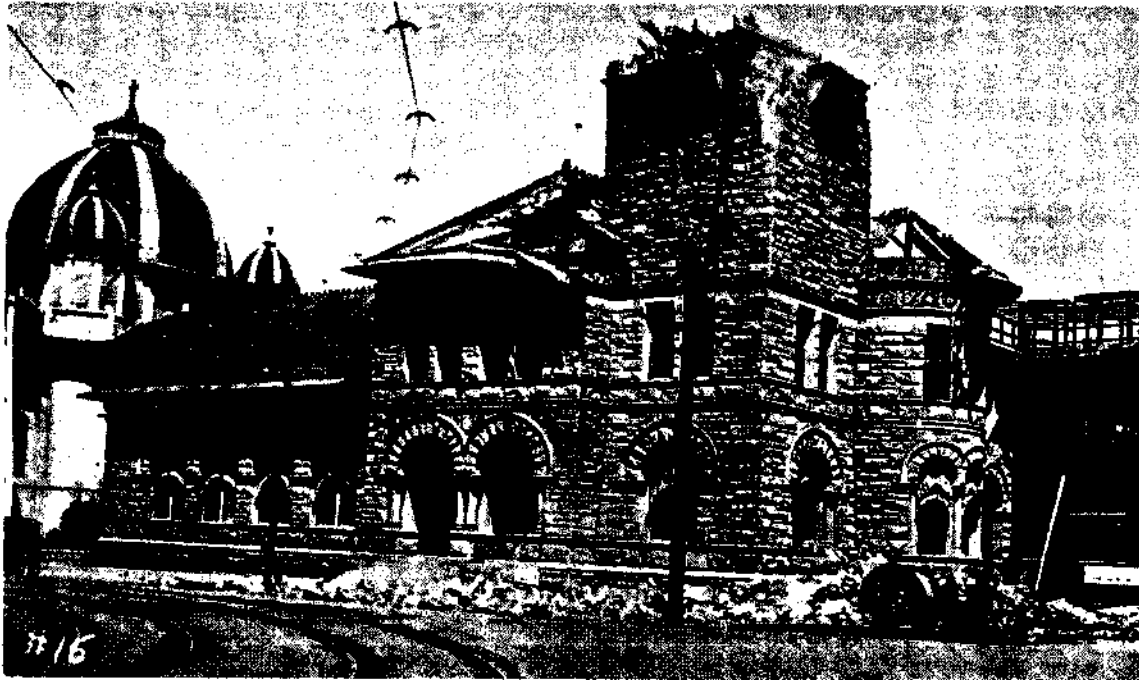

A. Post-office, San Jose!

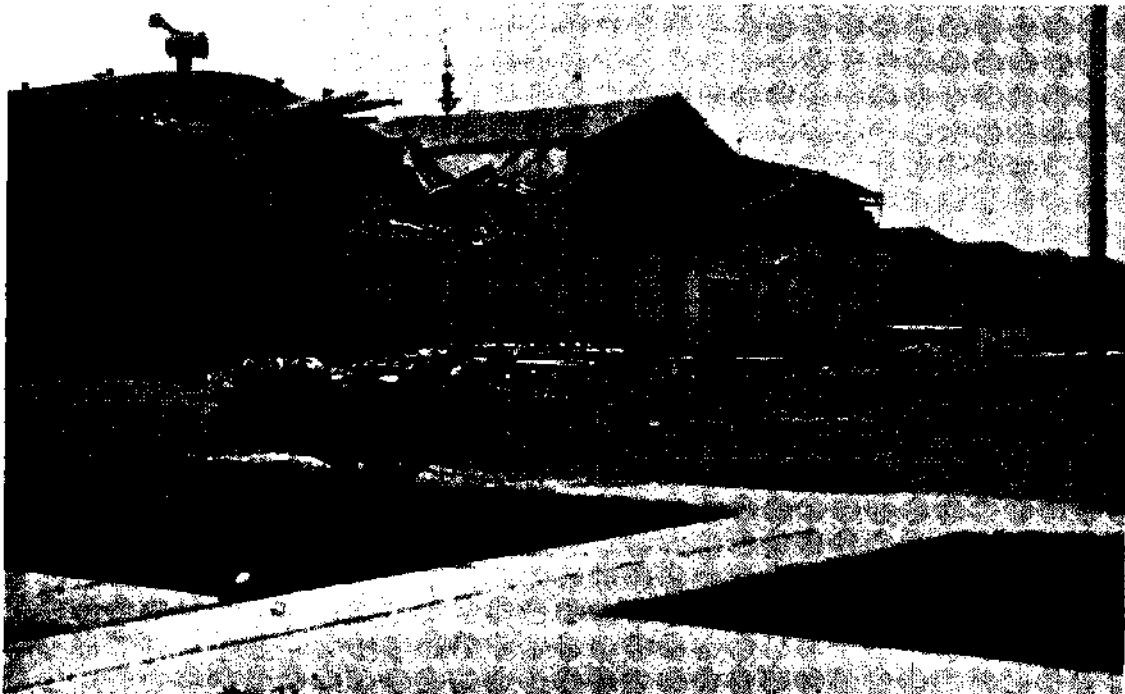

B. Box factory, corner Fifth and Julian Streets, San Jose. A. O. L.

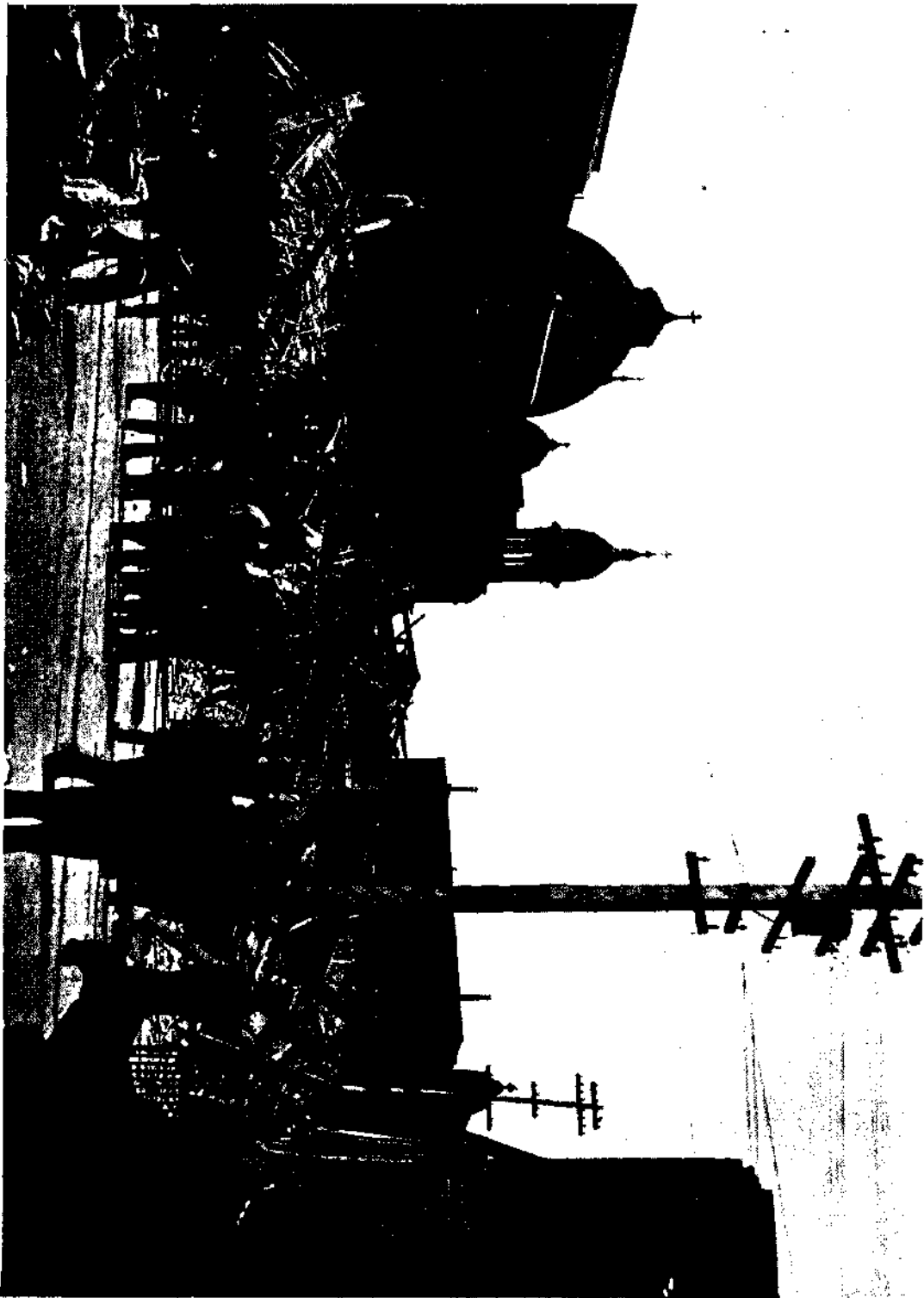

San Juan.

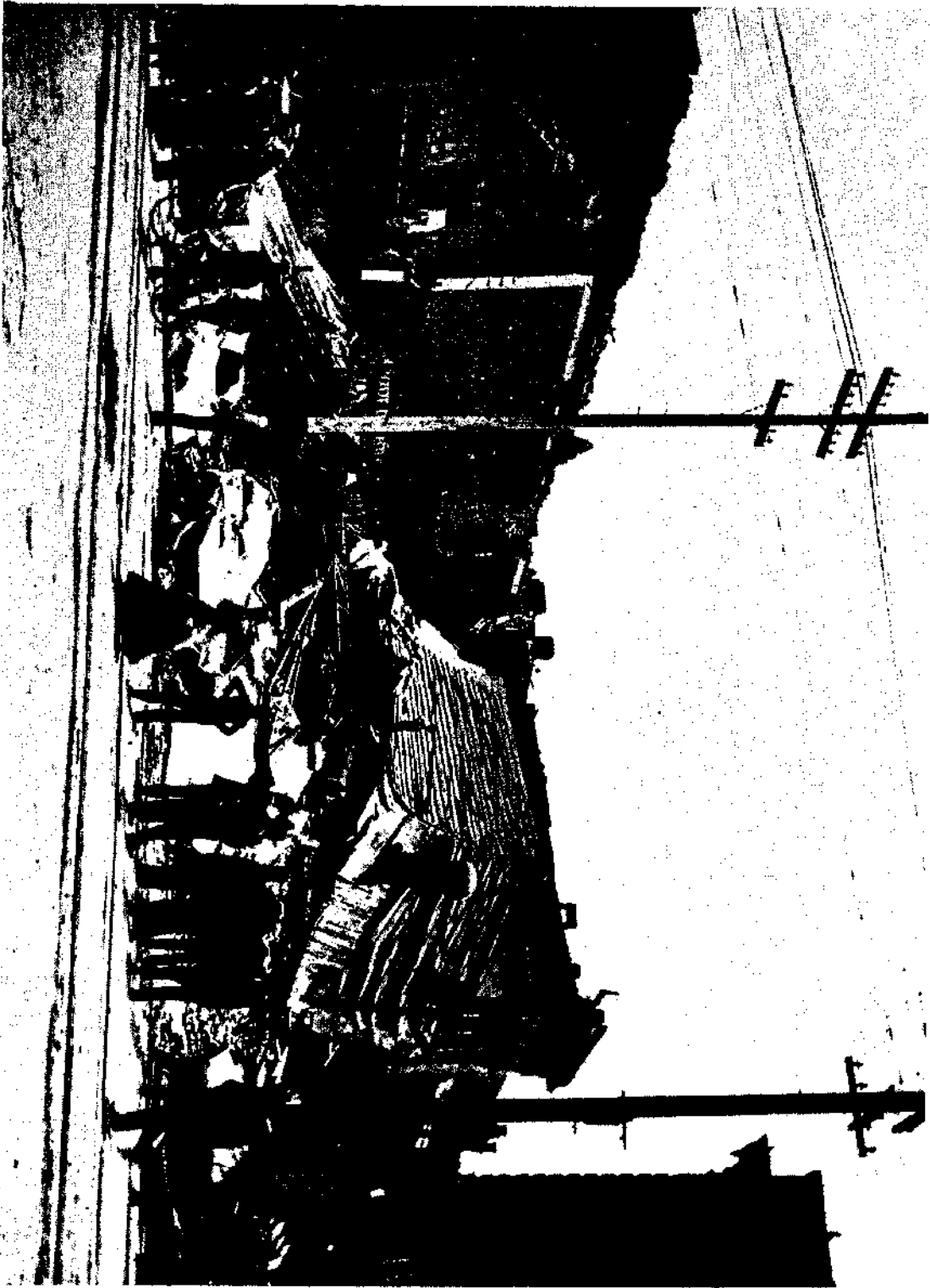

San Jose.





San Jose.

(E. C. Jones.)—There was only one broken gas main in San Jose, caused by the high wall of the building falling over; the bricks penetrated thru the soft earth to the main and broke it. At the gas station, the brick retort house was very badly damaged. The north and south gable ends fell out. The brick work at all 4 corners loosened for about 10 feet down to where the roof trusses are anchored in the walls. The superheater of one of the gas-making machines settled on the south side so that it was 2 inches out of plumb. The weight of this machine is about 78 tons. Some of the cast-iron connections in the building were broken.

The purifying house, also of brick, was totally destroyed; all the walls and the roof collapsed, carrying the machinery to the ground and destroying it. The relief gas-holder was full of gas at the time of the earthquake and was badly damaged. Two of the cast-iron columns were broken off in several places; portions of the railing fell thru the crown of the gas-holder, permitting the gas to escape. The distributing holder was three-fourths full of gas at the time of the earthquake. The movement threw about 12 inches of the water out of the holder tank. The carriages on the lower section were all broken, these being of cast-iron. The upper carriages, made of wrought iron, were strained but not broken. Considering the violence of the disturbance at this point, it is surprising that the mains did not suffer more than they did; but the breaking off of pipes in the buildings and the crushing of meters under falling houses necessitated shutting off the gas thruout the city for 24 hours.

(W. S. Prosser, C. E.)—Over the San Jose area, as a whole, the wreckage seems to have been thrown in all directions; but in certain places some slight system appears. It seems clear that no statement as to direction, amount, or even duration of motion applies to more than a limited area. The only clear cases of rotary motion seen by me were two cases near my home, 2 miles northwest of the center of town. One tank-house turned exactly halfway round, as well as upside down, and one chimney turned about 4 inches, both in the direction of the hands of a clock. Both rotary and vertical motions were felt by many, however. About 500 yards from me is a square brick fence-post 7 feet high, of which 2 feet moved about 3 inches to the southeast (S. 44° E.); or rather, the bottom moved the reverse way. On Stevens Creek road, leading southwest from San Jose, 5 or 6 water-tanks on the roadside fell. One of these seemed thrown to the northeast, but others were twisted and scattered as tho by a mixture of all motions. In some places most of the buildings, perhaps, fell to the north or northwest. In Chinatown (north of San Jose) it was the north and south brick walls that fell. In San Jose most of the clocks on east and west walls did not stop, but many of those on north and south walls did; showing an east and west motion. The brick 7-foot wall around the yard of Notre Dame School in San Jose, on the northwest side, fell; but that on the south did not, altho it was cracked. The streets in the central part of San Jose run N. 60° E.

The amount of motion differs greatly. In many cases brick work seems to show a sharp blow of 2 inches; sometimes more. The inside east and west wall of the City Hall has a crack of 4 inches. The front of La Mott House (east and west) moved in some places 2 inches, in others 4 inches. The master clock in the Western Union Office (on the ground floor of a large brick building, and on the east and west wall) did not stop, but the pendulum struck both sides of its case many times and with great violence, battering off the varnish. It is long (probably beats seconds) and had to move about 4 inches more than usual in order to strike the case.

About 5 miles south of San Jose there were said to be two tubs of water on the ground a few hundred yards apart. No. 1 had most of the water splasht out, but No. 2 apparently had lost none. No. 2 is nearer the hills, and bedrock is nearer the surface. The oil tank at the corner of Stockton and Polhemus Streets, 1 mile northwest of San Jose, splasht over. Many water-tanks did the same.

Several good observers out of doors are positive that the noise of the quake came from the southeast and died away toward San Francisco. In the afternoon of the 18th, my wife heard the noise of a shock and called out before we felt the shock itself. The noise seemed to come from the south or southeast.

Many persons saw waves in the ground. Sifting out exaggerations, these appeared to be rather more than a foot in height. The best observer estimated the distance from crest to crest at 60 feet, others at much less; but I think the waves must have been greater, for there is no evidence in long brick walls showing any such vertical cracks as would have been produced by short waves.

Six miles southwest from San Jose, a good observer described the waves as parallel with certain tree-rows which are northeast and southwest, and stated that the waves moved from him at right angles to the line and toward San Francisco. Six miles northwest from San Jose, a man looking south saw the waves (which he thinks were east and west) coming toward him, and hence toward San Francisco. About the middle of the quake these were met by other waves, and the whole surface resembled hillocks, or cross-seas, while the tree-tops waved wildly. To the man southwest of San Jose, however, the tops of the trees were almost still, while the trunks waved sinuously. Near me is a piece of ground 10 by 30 feet, raised about 7 inches; while about 150 feet southeast of this is an area about a yard square which dropt 6 inches. Possibly these represent the crest and trough of an earth-wave.

I estimate the duration, I think closely, at between 50 and 60 seconds.

The wells of the vicinity seem to show slightly increased flow. One 80 to 100 feet deep has been a little roily since the quake, and one near San Jose was reported as having increased the day before the quake.

(M. Connell.)—On the farm of Mr. Fox, 3 miles north of San Jose, the water pipe of an artesian well was broken off 60 feet below the surface and carried by the heave of the land in a northwesterly direction 4 feet from its original position.

*County road south of San Jose* (H. R. Johnson).—At Schutzen Park, 2 miles southeast of San Jose, the shock was felt quite severely. The road house was badly shaken, but very little glassware was broken in the bar-room. A 12,000-gallon water-tank was shifted slightly on its foundations. At this place the first part of the shock was thought to be quite light and the second part heavy; the general motion was said to be from east to west. At the 5-mile house, farther southeast on this same road, there was hardly any damage reported. Even plaster in houses did not fall. There was also little damage at the house 0.5 mile southeast of the 5-mile house. The chimney did not fall, but dishes and lamp-shades were broken. The movement was thought to be northwest-southeast in direction.

It was stated by Mr. Russel, of Edenvale, that the shock was lighter there than at San Jose. A well-constructed brick building, which was built 3 years ago, had the roof loosened and the end walls were cracked. About 3.5 miles southeast of the 5-mile house at the Van Every ranch, a chimney fell, plaster on the first floor was badly cracked, and furniture slid around upon the floor. Water was spilt from a tank and a water-trough.

Just northwest of the 12-mile house, where the county road crosses to the Fisher ranch, there were cracks from 2 to 6 inches wide in the coarse gravelly bottom of the Coyote River. There was evidence of water having been ejected from these cracks, as there were heaps of clean, fine material surrounding small orifices. It was said at the ranch-house that muddy water came out of these openings following the shock. Half a mile southeast of Fisher's, a water-tank was down.

Half a mile south of the 15-mile house, the Barnhart ranch-house, which was set upon wooden underpinning, was thrown from its foundation, so that it rested directly upon the

ground, 4 feet farther north than its proper place. An old barn and water-tank were uninjured at this same place.

A quarter of a mile south of the 15-mile house, on the county road, a water-tank was thrown down. Going 3 miles northeast from the 15-mile house, Webber's old ranch-house was visited. Here baled hay piled in a barn was shaken down and doors leaning against the house were thrown from their position. Water in both the creek (Coyote River) and a well was muddy after the shock.

(H. R. Johnson). — Going northeast thru San Felipe Valley to Smith Creek Hotel, hardly any evidence was seen of damage from the shock. At Smith Creek Hotel no china nor plaster was broken, but two chimneys were thrown down.

*Los Gatos to Gilroy* (G. A. Waring). — Near Meridian, 3 miles west of San Jose, several cottages were shifted from their foundations. All water-tanks on open frames fell, but those that were boarded in stood. The water became muddy in several wells. One lady reports seeing waves traveling southward along the driveway, and a man reports seeing a heavy wagon move 4 or 5 feet back and forth several times, along the driveway. The shock began violently and ended suddenly. The intensity diminished uniformly from Meridian toward Campbell. At Campbell, 68 per cent (51 out of 89) of the chimneys fell, but the plastering in the houses was not badly injured. From Campbell toward Los Gatos the intensity slightly increased. At Los Gatos 78 per cent (67 out of 86) of the chimneys fell. At the distillery 4 miles west of Los Gatos considerable damage was done. The second floor was moved about 18 inches toward the northeast, causing the wall to bow out on the northeast side. Many of the large vats holding 2,000 gallons were shaken off their supports and several were broken by the fall. The shock in Los Gatos, however, was not so sudden as to cause serious injury to brickwork or plastering. The business part of the town is built on 40 feet of gravel overlying shale. Only two stones in the Los Gatos Cemetery were shifted.

At Alma the shock was of about the same intensity as at Los Gatos. Milk in pans was nearly all thrown to the north and south. The Morrell house (see plate 107B), near Wright Station, is directly over the fault and suffered more than any other place in the vicinity of Wright Station, tho at least 5 other buildings between Patchin and Skyland were badly wrecked. Going from Los Gatos toward Edenvale, the shock was somewhat lighter than at Los Gatos, judging by the effect on chimneys, plastering, and movable objects; but at Edenvale it was a little stronger than at Los Gatos, as shown by the damage done to the large brick canning factory. All the walls were badly cracked and the tops of the walls fell. The top of the fire-wall above the roof was shaken down.

Continuing to the southwest thru Coyote, it was about the same as at Los Gatos, diminishing a little thru Madrone, Morgan Hill, and San Martin, where it had about the same intensity as at Los Gatos. Near Coyote a man reports having seen a northwest-southeast fence move in wave-like fashion, beginning at the southern end; and he heard a noise coming from the southeast and seeming to pass over him. Another man driving along the road near San Martin, heard a roar and his horse became frightened, before the shock came. Clouds of dust arose in the road and the creek near by was rendered muddy by the shock. At Morgan Hill about 64 per cent (18 out of 28) of the chimneys fell, and a 1-story concrete-block building was badly damaged, the whole front having fallen out. A 2-story reënforced concrete-block building was not damaged.

At Buckner, 3 miles north of Gilroy, the shock seems to have been about the same. The school building was badly damaged, and several windows were broken by the twisting of the frames. At Gilroy nearly every chimney fell, fire-walls of brick buildings were thrown down (plate 114A, B), and shelf goods were largely shaken down. In the Masons and Odd Fellows Cemetery, out of 120 stones over 3 feet tall, 31 fell. A cylindrical shaft fell north, and a square one fell south, but all the rest fell east or west, tho the tall slabs

necessarily fell east or west because they faced east. Two marble shafts about 8 feet high were broken off halfway up, the lower part and base being imshifted. In the Catholic Cemetery 10 stones out of 67 fell.

In the hills between Los Gatos and Gilroy the shock seems to have been somewhat less severe. At the New Almaden mines, the tops of 2 brick furnace chimneys, about 50 feet tall, were broken off; but the furnaces were unharmed and the underground workings unaffected. About 70 per cent (16 out of 23) of the chimneys in the settlement here (Hacienda) were broken off. A loud noise like thunder is reported to have traveled northward down the canyon, distinctly preceding the shock. This has often been heard since, seemingly underfoot, even when no shock has been felt.

Southward from New Almaden thru the hills the houses on alluvial land suffered noticeably more than those on more solid ground. From Uvas westward to the summit, the intensity rapidly rose as the fault was approached. Two miles west of Uvas P.O., and half a mile east of the summit, an east-and-west stone wall, built of loose boulders, was thrown mostly northward; water was thrown from troughs toward the north; and all streams were muddy for 2 days after the shock, while in wet places there was a noticeable settling of the ground.

Southward from New Almaden along the eastern side of the valley, the shock uniformly lessened in its intensity thru Old Gilroy and San Felipe to Hollister. At San Felipe a large stone cheese factory was not damaged, except for a few cracks. The lake 0.5 mile west of the village was considerably stirred up, and water from a full road tank was thrown 60 feet across the road. A considerable rumble was heard all thru this region; one person says it came from the southeast, traveling down the valley; another says it came from the southwest.

Along the railroad track from Gilroy to Sargent, nearing the fault, the intensity rose considerably, but the motion was a slow, swinging one. Water was all thrown from reservoirs, and trees swayed violently; but plastering and shelf goods suffered little. At Sargent all loose objects were thrown about, but no buildings were shifted.

(A. J. Champreux.)—About 90 per cent of the chimneys in Gilroy fell, the prevailing direction being east and west. No frame houses were thrown off their foundations. Brick walls were damaged at the top by the fall of 8 to 20 courses of brick. Most of the plastered houses suffered by the cracking of plaster. No cracks were found in roads or pavements. At the Cemetery, about 50 per cent of the monuments were overthrown. Of the fallen ones, 95 per cent were thrown in an east-west direction. All monuments overthrown had square bases.

#### HOLLISTER TO PRIEST VALLEY.

*Hollister* (G. A. Waring). — At Hollister (plate 114c, D) the chief damage was to the Grangers' Union, the Rochdale store, the Catholic school, and the fire-house. The two stores were poorly built, however, with large rooms unsupported by partitions or columns, while their shelves were heavily laden with goods. The school was on tall underpinning, very slightly braced, which allowed the building to lurch northward and settle to the ground. Unsupported parts of the fire-house walls (2 bricks thick) fell outward, but the portion braced by posts and tie-rods was unhurt. Sixty-five out of 123 chimneys fell, or 53 per cent. Several locked doors were thrown open, in one case the bolt being broken. One old settler remembers when the business part of Hollister was a slough. An artesian belt also passes thru the town, which may have affected the intensity along its path.

(A. J. Champreux.)—Practically all chimneys fell, the prevailing direction being east-west. One frame house, "School of the Sacred Heart," 2-story, was completely wrecked. The foundation gave way in the front part of the house, allowing the floor joists to drop.



A. Gilroy.

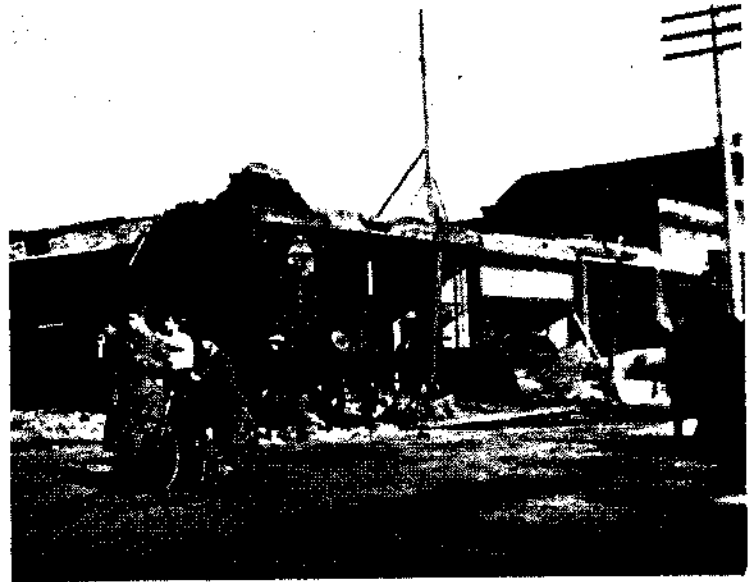

B. Gilroy.

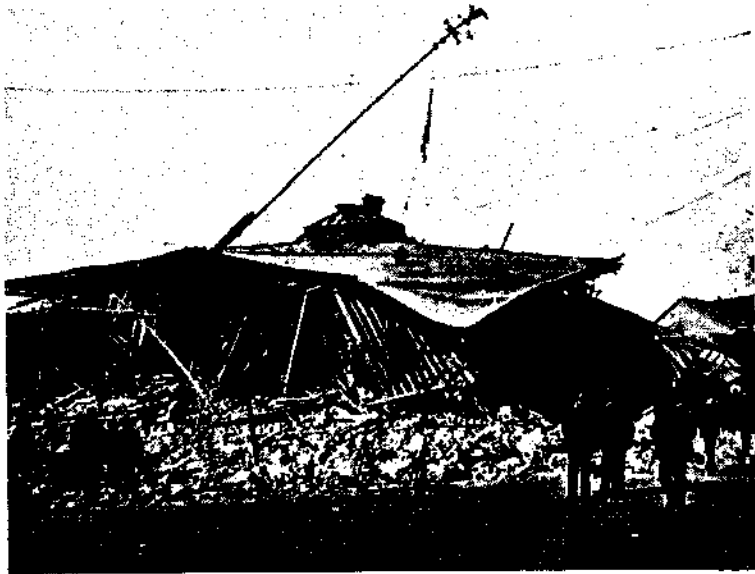

C. Hollister. Demolition of brick building shown in D. Blakesley Photo.

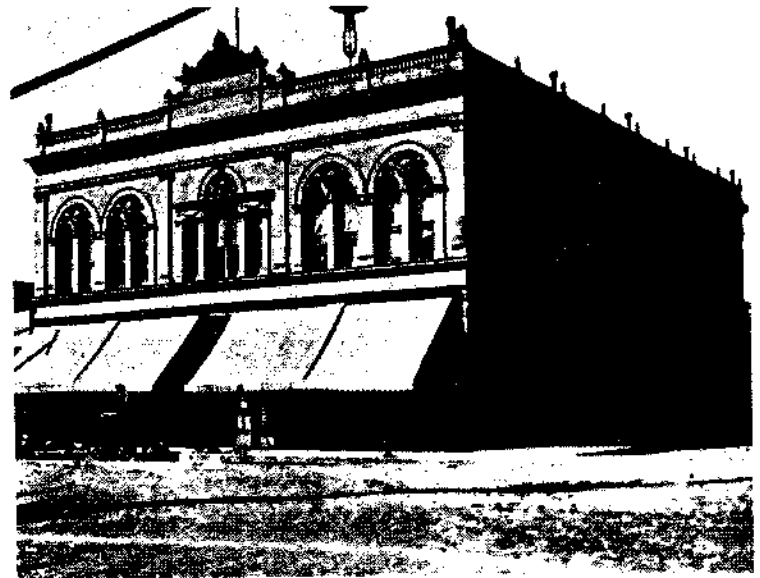

D. Hollister. Same building as shown in C, before earthquake. Blakesley, Photo.

This house was on the outskirts of town and on sandy soil. No other frame house was damaged. Two brick buildings, of poor construction, collapsed. The outer walls gave way, allowing the interior to drop.

(James Davis.)—Two shocks were felt, of which the second was the stronger. There was an interval of 3 or 4 seconds of less motion between these maxima. A rumble preceded the shock by a second or so. In my house a piano and other heavy objects were moved on a polished floor so that the north ends moved 2 or 3 feet out into the room farther than the south ends. I was standing at the time of the heaviest shock, and was thrown from side to side in a north and south direction. People here all agree as to the north and south direction of the movement. Most chimneys fell north, but some fell east and west. Pictures on east and west walls, hanging by single wires 4 to 6 feet long, swung from 3 to 8 feet along the walls, leaving distinct scratches. Pictures similarly hung on north and south walls simply pounded back and forth, leaving punctures in the plastering. Water-tanks seem to have fallen to the north always. Three brick buildings, each 2-story, 1 old and 2 new, went down flat, and 2 others were badly damaged. Wooden buildings in general were not damaged except thru the fall of chimneys. The Catholic convent, however, was injured.

There were no changes in the ground at Hollister save some slight cracks in the vicinity; but a small peak near Santa Ana showed a landslide down its steep face, plainly visible at a distance of 6 miles. A huge rock, rolling down a hill in Santa Ana Valley, crashed thru a house and killed a man.

(J. N. Thompson.)—All brick buildings were destroyed or badly damaged. There were 2 shocks, lasting in all about 50 seconds. The first appeared to be north and south, and the last part of the second shock appeared to be a twisting motion or a change to an east and west motion. My chimneys fell first, and nearly to the south; then at the last motion my wind-mill and tank fell to the west. The most damage was done at the close of the last vibration. A sideboard against a north wall was moved several inches to the south, and a clock on the same wall was thrown to the south. A bed against the west wall moved several inches to the east.

*From Hollister to San Benito* (G. A. Waring). — The effect of the shock upon alluvial soil is very noticeable. In the hills toward the Stayton Mines the shock was so feeble that it was not noticed by some people. Thru Brown's, Los Muretos, and Quien Sabe Valleys it was generally only sufficient to throw the cream from pans of milk. The often repeated story of the man who was killed in Quien Sabe Valley, by a rolling boulder crushing his house, is not to be accepted as a measure of the intensity. Several loose rocks were shaken down in the neighborhood of Santa Ana peak, and springs increased their flow; nevertheless the shock was very light.

At Palmtag's winery, in the hills southwest of Tres Pinos, the shock seems to have been more severe than elsewhere in the vicinity of that village. Furniture was moved, water was thrown from troughs, and an adobe building was badly cracked. One low brick winery was unharmed. A distinct rumble preceded the shock; 2 distinct periods were felt and the shock seemed very long. There is a small lake on the Palmtag place, and the ground seems rather marshy. Possibly this had some influence on the intensity, tho there is reason to believe that the projection of the fault passes thru the hills in the immediate vicinity.

At Tres Pinos, out of 18 chimneys only one fell and it was unstable. Shelf goods were almost unaffected. There is hard rock (sandstone or shale) in place, however, at a depth of 2 to 4 feet, at Tres Pinos.

Paicnes, tho south of Tres Pinos, was more violently shaken, for it stands on gravel. Milk and water were spilt somewhat, and a few tall bottles were thrown from the shelves. Water is said to have spouted up in the flat land along the river, 0.25 mile from the stream.

Toward the Cienaga lime-kilns the intensity lessened considerably. One man in the foot-hills 4 miles southwest of Paicenes, reports seeing a wave coming westward thru a grainfield, and some oaks waving considerably; but he did not hear nor feel any shock. Four miles southwest of Paicenes, a hanging lamp swung strongly east and west, and milk was spilt from the pans. At the kilns, in a granitic region, tho a distinct noise is said to have preceded the shake, only one slight shock was felt, and that was not sufficient to spill water from a full bucket standing on a table. Along the river between Paicenes and Mulberry, a distinct vertical motion is reported, causing weighted windows to be thrown up and down, and stove-lids to dance about. Liquids were strongly affected, as were trees and hanging lamps, and a few articles were thrown from shelves.

On the afternoon of June 13, a lady near Mulberry, 5 miles south of Paicenes, was talking over the telephone with a friend in Hollister. The latter suddenly gave a startled cry as a slight earthquake shock occurred. It was felt at Mulberry several seconds later. From Mulberry to San Benito the shock uniformly lessened until, at the latter place, altho distinctly felt, even liquids were not disturbed by it.

Thru Bear Valley the only noticeable effects of the shock were the swinging of lamps and the disturbance of water surfaces. Little or no sound was heard in Bear Valley, but several people noticed 3 distinct periods of vibration. It began easily, rapidly increased, and then, after a pause, there came a harder shake. At one house a lamp hanging by a chain 3 feet long is said to have swung north and south nearly to the ceiling. Articles on shelves were not moved, nor loose window lights shaken out. At the summit at the south end of Bear Valley, about a bucketful of water was thrown from a barrel only two-thirds full, and cream was thrown north and south from pans of milk. Here also the hanging lamp swung strongly north and south. A man outdoors became dizzy and nauseated, but did not at the time realize the cause.

Thru the south end of the valley, hanging lamps are said to have swung east and west, and water is said to have spilt mostly east and west. Several people became dizzy, but the motion seems to have been too slow to be distinctly appreciable.

At the Pinnacles no loose rocks were displaced, so the movement must have been slight.

Traveling southeastward from San Benito up the valley toward Hernandez, the motion consisted of longer, slower vibrations, and was of remarkably long duration. In general, the effect was only to set rocking-chairs in motion, cause doors to swing, and trees to sway. Just south of the divide between San Benito and Hernandez Valleys, the intensity rose noticeably, the shock throwing a lamp and clock from a shelf.

At Hernandez, pans of milk and troughs of water were almost emptied, and many minor shocks have been felt since. No noise was heard before the quake, but a report as of a blast immediately preceded the second (hardest) period of vibration. This is in an upland valley at 2,500 feet elevation, but the ground seems to be full of water.

In the mountainous serpentine area between Hernandez and New Idria, the shock was evidently slight, as nothing was noticed to have been disturbed at Smith's camp. At New Idria a few bottles and light articles were thrown from shelves, clocks were stopt, and a few bricks loosened from a building erected with mud mortar; but chimneys were not injured. One brick furnace was cracked, but it was not properly braced. Only 3 minor shocks have been noticed at New Idria. The intensity was about the same as at Hernandez.

In Vallecitos Valley, at an elevation of 2,000 feet, Tertiary rocks are overlain by 50 feet or more of alluvium. In this valley, pans of milk were slightly spilt, but nothing was thrown from shelves.

From San Benito southward thru the Bitterwater Valley, the intensity lessened, and only liquids were affected. The motion was too slight to be appreciable to some people.



*Priest Valley* (D. S. Jordan). — On May 18 I went to Priest Valley, in the southeast corner of Monterey County, 37 miles east of King City. I had heard that rumblings were frequently heard in the valley, and that people were moving out on account of them. There was little trace of the earthquake at King City. At Lonoak, 16 miles east, chimneys were thrown down and a mild earthquake was felt. At Priest Valley, which is near the line of the old fault and at the very foot of the main range of the Gabilan, the earthquake shock was very severe, apparently coming from the north. Chimneys were thrown down, dishes were broken, and the contents of the store thrown over the floor. Rumblings were alleged to have been heard by a man named George Brew. He had been hunting in the mountains, and said he had heard noises like cannonading in the ground at night. This was before the great shock.

There were slight landslides and cracks along the edge of the creek banks. There is, however, no trace of the great crack in the valley. No one had seen it cross the stage road; and the oil pipe line from Alcalde, in Fresno County, goes thru to the Salinas Valley without any break. The people said to be moving out of the valley were two frightened women up in a mountain gorge, whose husbands had gone to look after friends in San Jose. It is evident that the main crack did not reach as far as Priest Valley, and the shock at that point was not very different from that at San Jose, except that the blow was more direct, with less twisting motion.

#### MONTEREY BAY AND EASTWARD.

*Pacific Grove, Monterey, and Del Monte* (A. S. Eakle). — At Pacific Grove very slight damage resulted from the shock, altho according to residents the vibrations were very severe, in a northeast to southwest direction. Only one or two houses had chimneys cracked, tho there are several massive chimneys, some with heavy ornamental tops.

The town is situated on massive porphyritic granite, and the overlying soil is not deep. Its situation was evidently the reason for the slight damage done. The Pacific Grove light-house is situated about a mile southwest and this showed more severe effects. The lamp is enclosed in a ribbed metal frame which rests on a brick tower and dome. The vibration of the ribs caused them to strike the metal chimney in the center of the top and dent it on the easterly side. The motion of this upper portion caused the brick dome supporting it to crack immediately at the base of the curved dome. There was no displacement of bricks, the crack being a fine one, visible both within and without the tower, and completely encircling it. The light-house is built on a sand-dune and there is an estimated thickness of 80 feet of sand upon the underlying rocks. This sand foundation probably accounts for the apparently greater intensity of the shock here than in the town. Some of the objects in the rooms of the house were also slightly misplaced.

Judging the intensity of the earthquake by the damage it did in Pacific Grove, it would probably be classed as VI in the Rossi-Forel scale, as it was severe enough to awaken practically every one, tho no windows were broken, so far as could be ascertained.

Monterey experienced practically the same intensity. I could learn of no damage done to the houses, the only damage reported being of some glassware in a few stores. In some houses furniture was moved slightly, and top-heavy pieces were overturned. This town, like Pacific Grove, is on a good rock foundation; but in places the sand is deep-

Del Monte suffered the most, as practically every chimney of the hotel was cracked or thrown. There were over 50 chimneys in the hotel, and half of them were thrown down, one crashing thru the roof on the west side of the hotel and causing two fatalities. The chimneys were tall and top-heavy, having ornamental tops; and while the damage to the interior of the hotel was very slight, showing that the earthquake was not of a violent type, the vibrations were sufficient to throw these top-heavy chimneys. The hotel is on

alluvium, and the grounds surrounding it are in part "made" land. The grounds are surrounded by marshy land, ponds, and sand-dunes, and there is evidently a considerable depth of an incoherent, water-saturated formation supporting the hotel; this probably explains why Del Monte suffered so much more than Monterey. The houses adjoining the grounds were not damaged, with the exception of the school-house, which had its chimney cracked at the base.

On the road eastward to Salinas from Del Monte, no visible signs of the earthquake were encountered until the Salinas River was reached. The Salinas bridge was moved southerly several feet, according to report, and the framework was broken so as to render the bridge unsafe. The bridge farther down the stream, on a wagon road from Castroville railroad station to Monterey, was also damaged by the shock. This bridge crosses the river in a northeast to southwest direction, and is supported by four tiers of piles, boxed around with plank. The two end piers were not misplaced, but the two intermediate series were bent or broken at their bases and shoved over to the northeast, causing a sinking in the center of the bridge of about 2 feet. The damage to the bridge was due to the violence of the shock, and not to a sinking of the ground, as the amount of drop in the center was equivalent to the slanting position of the two intermediate supports.

*Castroville to Soquel* (G. A. Waring). — Castroville, being on solid ground, was not seriously affected. Three chimneys out of about 30 fell. Objects were thrown mostly westward. The quake was described as beginning like a subterranean blast. Two periods were not noticed; it was felt as one continual vibration, starting very gently.

The wharf at Moss Landing buckled up and partly collapsed, while the warehouses were wracked or fell westward. (Plate 116D.) At the hotel and stores on the mainland, brick chimneys fell, but plastering was not seriously cracked.

At Watsonville about 90 per cent of the chimneys were broken off at the roof-line, the greater portion being near to the river. Several were cracked and twisted but not thrown down. Parts of a few brick walls near the river fell, and considerable settling of the ground took place in Chinatown on the southern side of the river. (Plate 116A.)

On the higher ground between Watsonville and Aptos, the shock was little felt. There was no movement along Aptos Creek, both wagon and railway bridges being unaffected.

In one old house about half the plaster was thrown from every northern and southern wall on the first floor, but not from the others, nor from the upper rooms. A bureau was moved eastward 3 feet from the wall, but no other furniture was moved.

Nearly all the chimneys at Capitola fell, and considerable plaster was shaken from the north walls of the first floor of the hotel. The vibration is said to have been almost entirely east and west, as shown by the sash locks having been broken only upon the east and west windows. An iron safe free to move northward was unmoved, but the plaster on the opposite side of the wall back of it (west) was broken. A case of pigeon-holes resting on top of the safe slid to the east edge, when it could as easily have moved north. Much earth fell from bluffs near the town, but there was no appreciable effect on the surf. At the country bridge across Soquel Creek, the ground at the east abutment shoved inward, cracking the concrete and buckling a water-pipe.

In the low ground at Soquel, nearly all the chimneys fell, but most of those on high ground stood. Much plaster fell and goods were thrown from the shelves in the business section, which is close to the creek. The east abutment of the concrete wagon bridge over Soquel Creek cracked vertically, showing that the soil movement extended this far up the creek. Thru Delmar, Seabright, and Twin Lakes nearly all the chimneys were either down or twisted part way around and left standing, an unusual number being thus twisted. The shock is said to have come suddenly, diminished, and then, at a second jolt, chimneys fell. Trees moved sideways as well as swayed, and all animals were much frightened. One small stream has diminished in flow.

(D. Stirling.)—In the Pajaro Valley, on the McGowan ranch, at a bend of the river, an acre or more of orchard has sunk about 2 feet. At Moss Landing, where the river runs parallel with the shore line, the strip of land is seamed for miles. A crack, or rather a sink, about 20 feet wide and 4 or 5 feet deep ran under the buildings and rent them asunder. The office building between this crack and the river has been moved bodily—land and all—about 12 feet toward the river. Some of the cracks run into the ocean. At Neponset and Salinas the piling under the county bridges was moved in some of the bents at least 10 feet toward the river. A section man who stood in the midst of the cracks at the end of the Neponset bridge was drenched with spurting water.

#### SALINAS TO SAN LUIS OBISPO AND WESTWARD.

*Effect of the Shock on Alluvium* (G. A. Waring).—Altho the Salinas river bed sank nearly 6 feet at King City, and the wide sandy bottom at Three Mile Flat was much cracked, the southernmost extension of continuous cracks along the bank was found to be about 2.5 miles south of Gonzales bridge. From here to the mouth of the river the cracks are parallel with the river banks.

The movement at Gonzales bridge was mostly on the west bank of the stream. A wire fence trending north and south was torn 6 inches apart here, and wooden piles at the southwest end of the bridge, said to be driven down 75 feet, have been torn loose and moved from plumb, their original upright position. At the northeast end of the bridge the piles are undisturbed, but the surface soil and a wire fence have moved relatively 18 inches northward. (See fig. 59.)

North of Gonzales bridge the fissures are mostly on the west side of the stream channel, and reach a maximum width of 18 inches. No evidence of shearing could be found. In the creek bottoms west of Chualar, sand craterlets begin to appear and become numerous along the stream northward.

Near Agenda, in the lowlands, is a cracked area nearly a mile from the river, probably along an old water course; while sand craterlets are scattered thru the orchards. At Spreckels the movement caused much damage to flumes, sewers, and water-mains; and from here to Blanco the deep soil of the adjacent fields is much cracked and in places sunken and dotted with sand craterlets.

The county bridge south of Salinas was rendered unsafe by the movement of the piers at the southern end. (Plate 123A.) On the west bank near the bridge a series of peculiar cracks have torn up the road and adjacent field, along what is probably the path of an old water course. These are shown in plates 136, 137.

Between Blanco and Neponset the cracking and settling of the low land flooded the adjacent fields and gave rise to stories about the Salinas River having risen several feet. The "boiling up" of the water thru sand craterlets was also soon distorted into a story about the water of the Salinas River being boiling hot. Both the railway and county bridges at Neponset were moved, the northern concrete piers of the former 2 inches east and the central wooden pier of the latter apparently 4 feet south.

From Morocoho to Moss Landing fissures rarely show in marshy land, but the narrow-gage railway track has been shifted a few inches in several places. At Moss Landing many small cracks occur in the mud on the west side of the river, and the condition of the wharf indicates an eastward movement of the sand-spit. (See plates 134B, 135A, B.) It is reported that at places along the pier where the water was formerly 6 feet deep, it now has a depth of 18 or 20 feet. North of Moss Landing the ground settled nearly 2 feet in places, as shown by marks on railway piles at several slough crossings and by the sagging of the track below grade line in several other places. The stretch of narrow-gage track parallel to the coast has been disturbed for nearly its whole length; in some places it is wavy, in others the entire roadbed has shifted. At one point about 5 miles south of



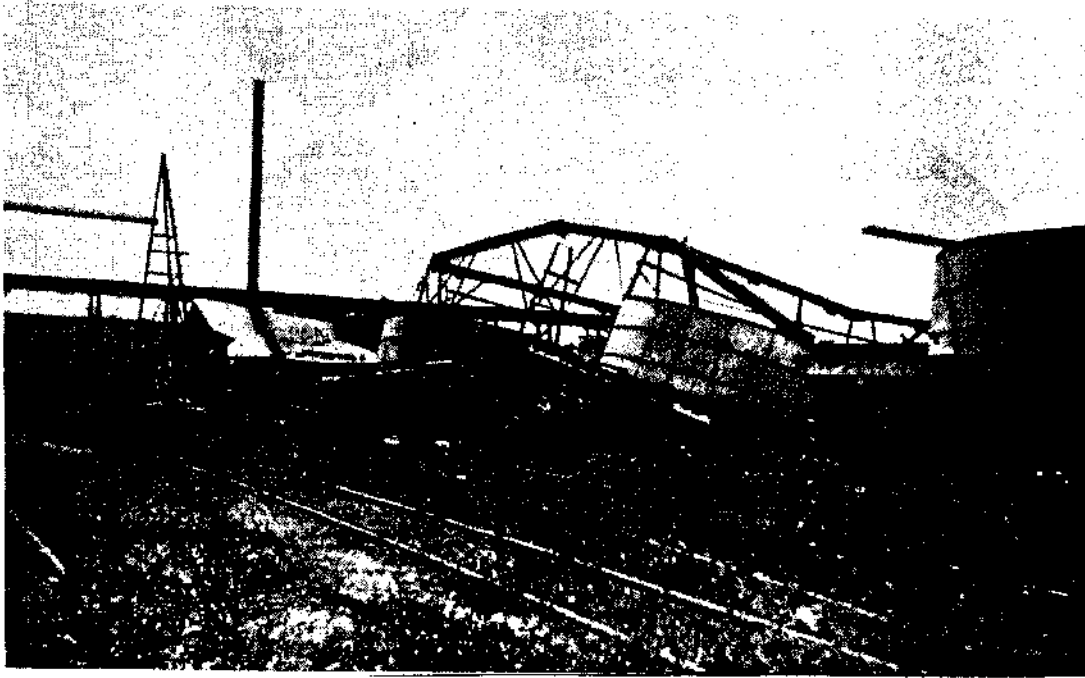

A. Alvatadoi Wreok of molasses tankB, Alameda Sugar Company, E. W. B.

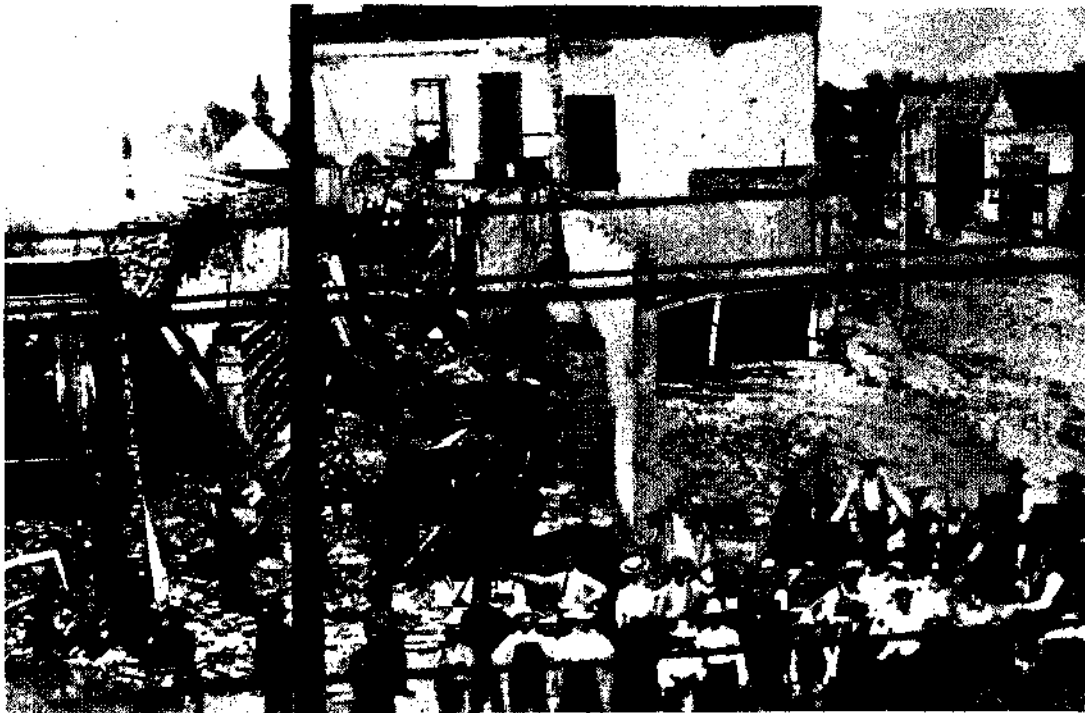

B. Salinai. Wreck of corner ttor\*. & B. B.

10 feet at Gonzales bridge and ending about 2.5 miles south of it. Along the Pajaro and San Lorenzo Rivers the movement was a settling of the alluvial bottom-lands.

(A. S. Eakle.) — The effect of the earthquake upon the alluvium was well shown along the banks of the stream from the Salinas to the Gonzales bridges. Along the east side of the river for a short distance south of the Salinas bridge, 4 miles south of the town, the land is cracked at the edge of the bank, the cracks paralleling the course of the river; but comparatively little cracking was observed on this side of the river. Along the bank and down in the river-bottom itself, on the western side of the stream, fissures were very prominent. The county road southward from the Salinas bridge runs along the embankment about 10 to 20 feet above the stream bed. The road is an oiled one, and the oil had formed a hardpan upon the underlying sand. In the vicinity of the bridge the road has been shattered by the quake for a distance of 200 yards. The breaks are in the nature of a caving in of the road on the north side of the crack, as if hollow spaces existed beneath, leaving a vertical escarpment on the south side. The main sinking is at the most southerly fissure. Here the road has sunk bodily to a depth of 10 feet, leaving a high vertical bank diagonally across the road, and this sunken area extends for some distance into the adjoining field on the west. There is no upheaval of the road in any place to compensate for the sinking.

South of the Spreckels factory, the low bottom-land between the banks of the river is considerably cracked, although there is no prominent vertical dropping of the land along the cracks. This low land lies west of the present course of the stream, and is intersected by sloughs and former water courses. All of the ground is of a deep sandy nature, consequently it was much disturbed and fissured by the quake, and the fissures became filled with water and sand, forming a quicksand, this wet sand frequently being spouted into the air. No one noticed gases coming up. The position of the cracks is now marked by patches of light, bluish-gray sand in the field, from the drying out of the quicksands. Houses on this low land were thrown out of plumb, and chimneys were destroyed. The cracks diminish in number as one goes southward, and practically end in the vicinity of the Gonzales bridge. The quake at Gonzales can hardly be placed at more than VII in the scale, as comparatively little damage was done to the town.

*Effect upon structures, objects, etc.* (G. A. Waring). — It is remarkable how closely the disturbance followed the river channel throughout the Salinas Valley; 2 or 3 miles away from the stream on both sides the intensity was very slight. Southward up the valley the shock gradually lessened, and rapidly died out in the foot-hills on either side.

In the hills between San Juan and Natividad the ground is not cracked, except for a few places on hillsides where there was some sloughing off. The shock was sufficient to throw nearly all the milk from the pans, but not strong enough to move furniture or shelf goods. At Natividad, in the foot-hills, the shock was of about the same intensity. At Santa Rita the shock was light; a little milk was spilt from pans, but several tall slender chimneys were unhurt.

*Prunedale* (H. H. McIntyre). — Nearly every chimney was thrown down. All the goods in the store were thrown to the floor. The house was badly wrecked. Water started flowing in many places where there had been none, or but little, before. There were 2 small landslides from springy places, the direction of the slip being from north to south.

*Salinas* (G. A. Waring). — At Salinas 42\$ per cent (278 out of 655) of the chimneys fell. A brick store was demolished by the collapse of the roof (plates 115B, 116B), and parts of a dozen or more brick walls fell. (Plate 116c.) Shelf goods were shaken down, and a few heavy articles, such as slot machines, were overturned. Heavy furniture, such as pianos and billiard tables, was not moved. But little plate glass was broken. In

some buildings plastering was badly cracked and shaken down, but in solid, well-built residences it was little hurt. The court-house and high-school buildings, within a block of each other, furnish striking examples of the need of considering construction when trying to gage the intensity of the shock by its effect on buildings. In the former building the principal damage consists of a few cracks in the plastering and foundations, while in the high-school building a part of the front wall fell out and the roof spread badly, cracking the corners of the house.

(A. S. Eakle.)—The town of Salinas suffered greater destruction than any other place in the county. Nearly every house and building were damaged to some extent. Plaster fell, windows broke, chimneys fell or were cracked, and brick buildings had their upper portions thrown off and, in some cases, almost completely demolished. The town is on the flat valley land, about 3 miles east of the river, and came within range of the more violent vibrations, in addition to being on alluvium.

*Spreckels and vicinity* (G. A. Waring).—The village of Spreckels, on the river-bottom, was badly shaken. Nearly every one of the approximately 50 chimneys in the settlement fell, as did also a large part of the plaster in the 3-story hotel. On the first floor of the hotel building nearly all the walls were stript, but the plaster fell mostly from the south wall. On the second floor the walls of the north end and west side suffered most, while on the third floor the north end (walls and ceiling) was shaken the hardest. In the 6-story, steel frame, brick sugar mill (plate 117A, B) the bricks along the I-beams of the north end were thrown out, as were also those of the upper central part of the west wall, and part of the top cornices of the north and south ends. Oil in a large tank was thrown toward the southeast. The front (north end) of the 2-story brick office building exhibits a remarkably symmetrical set of cracks.

(A. C. Lawson.)—The flood plain of the Salinas River was caused to lurch toward the stream from both sides, but the effects are most marked on the south side. The result in most places has been the breaking up of the alluvium into monoclinical strips with a vertical scarp on one side, facing the river, and a gentle slope on the other. These have the effect of landslide scarps and terraces, but occur on flat land. In some instances it would appear that the ground had collapsed into the cavity formed by the lurching. There are minor cracks and buckles in the sand and mud flats of the river-bottom. Here numerous craterlets were formed by the sudden ejection of water from the underlying sands, due to the compressive action of the shock. This acute deformation of the ground accentuated the destructive tendency due to the earthquake shock.

At the bridge, a large trussed structure in 2 spans having a bearing of N. 27° E., the south pier, consisting of 26 piles incased in planking, was thrust to the south between 6 and 7 feet, so that the entire pier was inclined as shown in plate 123A. The piles were not broken at the ground level. The north and middle piers were apparently not affected. An oil pipe which crost the bridge was buckled and twisted at the south end of the bridge, and when this was repaired the pipe was found to have been shortened 7 feet. The pipe line extends from the San Joaquin Valley to the Bay of Monterey. A few hundred yards to the south of the bridge is a pumping station, and at this point some of the connections of the pipes were broken and displaced. The direction of the shortening of the bridge span and the pipe is roughly normal to the direction of the San Andreas Rift, on the other side of the Gavilan Range. Mr. S. A. Guiberson, superintendent of the line, reports that the pipe was broken in about twenty places in the vicinity of the river, and that at some of these breaks the pipe was pulled apart.

A few hundred yards east of the bridge, on the south side of the Salinas River, is the Spreckels sugar-mill, a steel structure incased in brick, about 500 feet long and about 150 feet wide, having a northeasterly and southwesterly orientation. This building is five stories high, but the five stories occur only at the two ends of the building. In

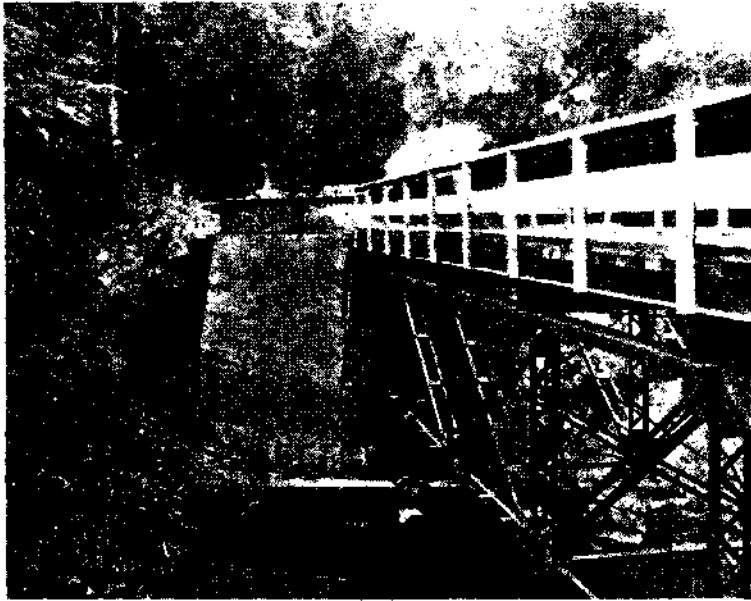

A. Near Watson-rille. Concrete pier of bridge shattered! Per J. O. B.



B. Bflnas. Wreck of store. & B.B.

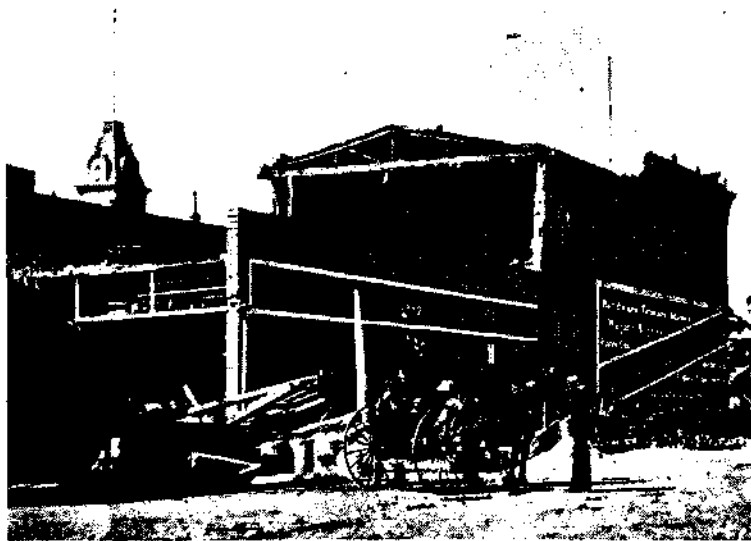

C. Salinas. Wall of building thrown out. G. E. B.



D. Hoss Landing. Wreck of wooden warehouse. G. B. B.



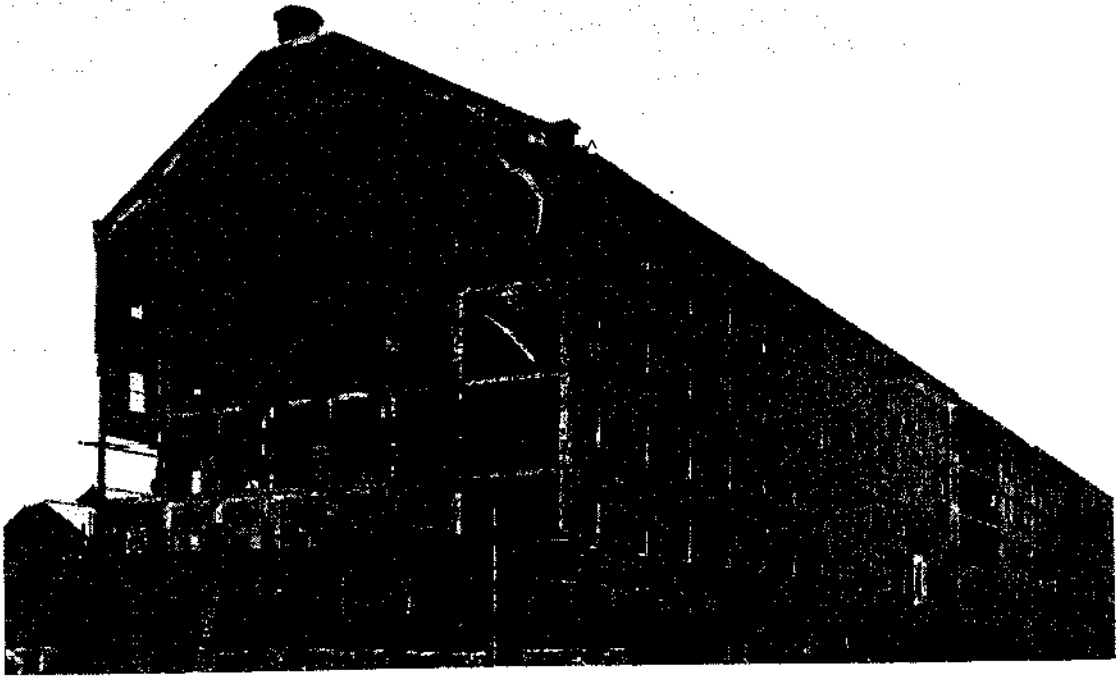

A. Spreckela sugar mill, near Salinas. Entire building buckled. Looking southeast. R. L. H.

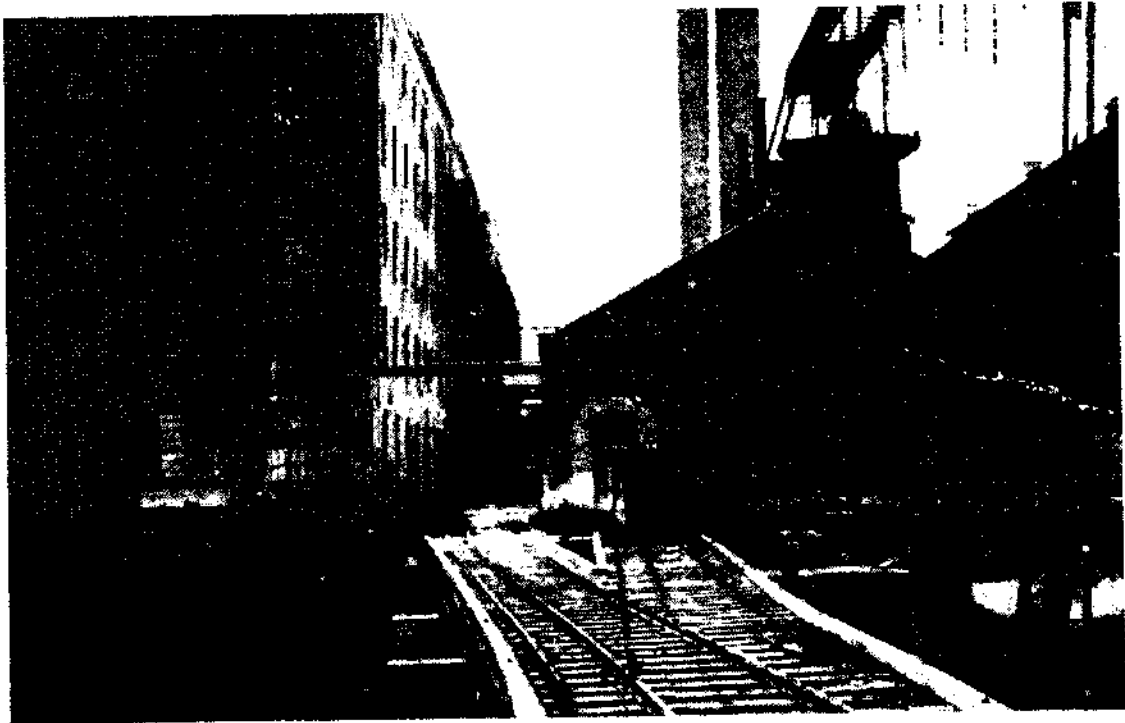

B. Spreckeli sugar mill, LooHsg northweit. A. O. L.

the middle 100 feet of its length there is only one floor above the ground-level, and above this the structure is open to the roof, without cross-ties or floor-beams. This building yielded to the shock in a most remarkable and instructive manner. The whole structure was shortened along the line of its longer axis, this shortening being effected by the buckling of the walls at the middle or weak portion of the building. Both walls bulged toward the west, the east wall in and the west wall out, as shown in plate 117A, B. Within the building considerable damage was done to the heavy machinery, tanks, etc. The ground to the south had been much heaved and otherwise deformed, causing the wrecking of trestles, pumping-house, and other structures. The rails of a track at the rear of the building were pulled apart, due probably to the slumping of the ground toward an old slough of the river.

In the bottom of this slough water gushed forth at numerous places at the time of the earthquake. It is said by those who witnessed the phenomenon that the water spurted repeatedly as high as 20 feet, and that the outflow of water lasted for 10 minutes after the shock. The places where the water spurted forth are marked by areas of fine, light, bluish-gray sand, which is said to be known only at a depth of 80 feet in the various well borings of the vicinity. In these areas of fine bluish sand are often funnel-shaped depressions or craterlets from which the water issued.

(S. A. Guiberson, Jr.)—As superintendent of the pipe line, I am in a position to say that we have no breaks whatever in any place between Coalinga and the Salinas River, and there were no fissures of any kind along the line between these points. This I know positively, as I have line riders who were instructed to look closely for any disturbance of this nature. The line of fissures seems to have ended north of Priest Valley. The conditions prevailing along the Salinas River, and some of the peculiar circumstances attending the breaking of our line in\* about twenty places, are of interest. I was on the ground the following day, and only regret that I did not have time to have some of the peculiar features photographed. In places our line had been broken and the ends were 3 feet apart; at the same time the ends of the pipe would be hammered up, showing that there had been an opening and closing movement at that point, while at other points the line would overlap as much as 4 feet. One of our stations is in this zone of disturbance, and the engineers, being on duty, had an excellent opportunity to see what most of us who were in bed merely felt. They state that these fissures were opening and closing, and that the water and sand would go 20 feet in the air as they closed.

*Southward from Salinas* (G. A. Waring).—At points along the railroad liquids were generally spilt, furniture was moved, and chimneys cracked. At Chualar, 3 out of 29 chimneys fell, but 2 were on an old house and were probably weak. At Gonzales the intensity seems to have been about the same as at Chualar. Out of 150 chimneys 11 fell, while many were cracked. East of Gonzales, near the foot-hills, houses were barely shaken; while to the west, near the river, water-tanks were thrown down. At Soledad 3 out of 8 chimneys fell, but the number is probably too small to be taken as a criterion of intensity. Some plastering on the first floor of the hotel was slightly cracked, a few glasses were thrown from the bar, and some of the bottles were turned around. The frame of the railroad tank was so badly twisted that it had to be taken down. A chandelier swung northeast-southwest with a double amplitude of 18 inches.

At King City, close to the river and on low ground, the intensity was considerably higher than at Soledad. Heavy objects, such as a printing-press, slot machines, and ice-chests, were shifted a little, and a few things were thrown from the shelves. One low chimney on a low fire-wall fell, but the wall was without a crack. No other chimneys were injured. The river-bed sank nearly 6 feet in the vicinity of King City. At San Lucas the intensity was considerably lower; milk and water were spilt and shelf goods disturbed, but no chimneys fell.

On the western side of the valley from Salinas to San Lucas the same kind of evidence was found as at corresponding points on the eastern side. At Fort Romie most of the clocks stopt, a few articles were thrown from the store shelves, and water in a north and south canal was thrown over the sides. No sound was heard during the shake, but it is reported to have come afterward.

About 4 miles south of Fort Romie, water was thrown 30 feet northward from a full tank, the top of which is 14 feet above the ground, and half the milk was thrown from half-filled pans. West of San Lucas, waves were reported to have been seen moving southward over the hills and a sound to have been heard. The shock began gently, was followed by a harder shake, and died away slowly. Thru San Ardo, Bradley, and San Miguel, the shock lessened uniformly. At San Ardo a water-tank frame was somewhat wrenched, and the river-bed is thought to have sunk about 2.5 feet, the evidence of this was not obtained. Oil was spilt from a large tank, and quicksand was thrown up in a well, which seemed to lessen the flow considerably. The railway station at Bradley, standing on made ground, settled 2 inches at one end.

At Paso Robles a number of clocks were stopt, most of which were facing east or west. Window weights rattled and lamps swung about, but plastering and shelf goods were not affected. The duration of the shock was estimated at 40 seconds, but was very-gentle.

In the southeastern end of the Salinas River drainage area, at Shandon, Cholame, and Parkfield, the shock was notable as being "the longest, easiest one felt in many years"; liquid surfaces were somewhat disturbed, a few clocks were stopt, and hanging objects were set in motion. In the hills 2 miles northwest of Shandon the intensity was somewhat greater, as it was also to the southeast in the Red Hills. At Shandon, a saddle hanging by a wire from the rafters swung north and south, and water was thrown from a full horse-trough. The shock was also reported at Estrella and Linne.

*South and West of Salinas Valley* (G. A. Waring). — Following southward over the divide thru Templeton, Santa Margarita, Dove, and Guesta the shock lessened until it was hardly more than distinctly felt. At Templeton skimmed milk was spilt at one place, but unskimmed milk was not. At Dove the swaying of the telegraph wires was about the only evidence noticed. At one place a mile east of San Luis Obispo a great roar is reported to have been heard.

In the coastal range of hills thru Carmel P.O., Jamesburgh, and Jolon, only milk and water were disturbed, but from the latter place to Los Osos Valley, west of San Luis Obispo, the shock varied considerably. At Lockwood the shock was a little stronger than at Jolon, clocks being stopt generally and milk and water spilt, but no shelf goods were moved. Thru Hames and Pleyto it hardly more than wakened sleepers, and people moving around did not feel it; while at Adelaide clocks were stopt, shelf goods moved, and liquids spilt. Several minor shocks have also been felt at Adelaide. In Los Osos Valley, however, the shock was barely felt; sound sleepers were not awakened. A few light things, such as table covers, swayed slightly, but no sound was heard, and pans of milk were undisturbed.

At San Luis Obispo the shock was hard enough to waken all ordinary sleepers. Some people thought it a wind-storm. The vibration is estimated by some to have lasted 20 seconds. Mr. John R. Williams states that the shock made doors and windows rattle, moved his bed, and stopt some clocks. There was but one principal disturbance, which gradually increased in intensity and then died away, lasting about 50 seconds. The apparent direction of movement was northeast and southwest. The night operator at the telephone office was talking with Salinas at the time the shock occurred. She heard a scream at the Salinas end, followed by a roaring sound. Fully half a minute later the shock was felt by her at San Luis Obispo.

Along the coast northward from Port Harford thru Morro, Cayucas, and Cambria, to San Simeon, the intensity gradually rose. At Morro some people in bed and awake felt it; many others did not; while at San Simeon liquids were somewhat disturbed and the shock of the afternoon (of April 18) was also noticed, which was not the case farther south. At Piedras Blancas Light-house a clock stopt and the shock was distinctly felt.

Between San Simeon and Posts the country is almost uninhabited, and not easily accessible, so it was not visited. At Posts a clock was stopt. The shock was very appreciable, and several minor ones have been felt since. At Idlewild several articles were thrown from shelves, windows rattled, and the redwoods swayed considerably. At Sur a clock was stopt and the shock was apparently a little stronger. At Carmel-by-the-Sea, on deep, sandy soil, several people ran out of doors, a cobble-stone chimney fell, and a few tall articles were tipt from shelves.

#### SAN LUIS OBISPO TO SAN BERNARDINO.

This portion of the state is on the southern fringe of the region within which the shock appealed to the senses. The shock was not exceptional in intensity and the people paid little attention to it; therefore records of observations as to the effects produced are few. Such reports as have come in, however, indicate that the shock was more or less distinctly felt thruout the country north of the Santa Barbara Channel and the Valley of Southern California, as far east as San Bernardino.

*Arroyo Grande, San Luis Obispo County* (G. P. Ide).—Pendulum clocks facing north and south were stopt, while those facing east and west were not. Very few objects were overthrown. A hanging object swung east and west in an elliptical orbit.

Other points south of the town of San Luis Obispo at which the shock was reported are:

*Pismo*: Hanging objects swung from east to west, and some clocks stopt.

*Edna and Oceano*: Clock stopt.

*Port Harford*: Slight shock.

*Santa Maria, Santa Barbara County* (F. R. Schank).—I was asleep in the second story of a brick building and was awakened by the first of 3 shocks. The shock awoke people generally and was observed by persons moving about, but did no. damage. The motion was a slow, easy one. Wooden inside shutters at my windows swung thru a considerable arc, and an incandescent lamp suspended by about 5 feet of cord vibrated with an amplitude of about 6 or 7 inches in a plane approximately east-northeast. The length of the first and second shocks was 1 or 2 seconds, but the third shock lasted between 12 and 15 seconds.

*Casmalia, Santa Barbara County* (C. H. Stephens).—I was awakened by the jar, and the rocking was continued for about a minute, when all became quiet. It then started again lightly, getting stronger as it proceeded and gradually dying away in about 45 seconds. The third shock came quite strong, and 6 waves followed close on each other, each stronger than the preceding one. The clock was stopt, and some articles of furniture were overturned.

*Surf*.—A clock was stopt.

*Lompoc, Santa Barbara County* (O. K. Studley).—I was in bed, awakened by the first slight trembling. My bed stands east and west, with the head to the west. The first shock moved me up and down from head to foot. The second shock rolled me from side to side. The first shock gradually increased to a maximum, and then died out; the second seemed to be about the same intensity thruout, and stopt suddenly. The latter set the window weights on the south side of the house rattling quite rapidly. The hanging lamp suspended from the ceiling of the lower story by a chain, which would make it about equal to a pendulum that beats seconds, swung in an elliptical orbit, the longer

diameter being 10 inches in a west-northwest direction and the shorter diameter 4 inches in a north-northeast direction. The motion in the ellipse was clockwise. The clock stopt.

*Point Conception Light-house Station* (Mr. Austin). — While cleaning up in the tower at 5<sup>h</sup> 20<sup>ra</sup> A.M., the keeper felt the lens shake. No one else at the station felt the shock.

*Santa Barbara* (J. A. Dodge). — I was aroused from a half-sleeping condition by a singular rustling noise in the house. None of us recognized it as an earthquake at the time. My bed was not perceptibly shaken. Nothing was shaken out of place, no plastering was cracked, and no clocks were affected. The sound referred to was produced by something in the structure of the house creaking or vibrating. Other reports state that some hanging objects were caused to swing, and that one woman was made dizzy.

*Carpenteria, Santa Barbara County*. — The shock was sufficient to rattle dishes and slightly move beds, but few people were awakened by it.

*Saticoy, Ventura County* (E. O. Tucker). — Water in a trough which was 6 inches from being full, slopt over nearly a pailful at a time from the ends. The trough lies from north-east to southwest. A rattling noise was heard in the house, but no motion was felt.

*Hueneme Light-house Station, Ventura County* (C. F. Allen). — The earthquake was one abrupt shake which gradually died out, lasting 4 seconds in all. The weight to the clockwork which turns the light thumped back and forth in the weight-well from north-west to southeast, and the window weights did likewise.

In Ventura County a slight shock was reported at Newberry Park, Punta Gorda, and Ventura. At the latter place, hanging objects were observed to sway from east to west.

*Calabassas* (H. H. Wheeler). — A farmer stated that a number of cisterns for collecting rain-water for domestic uses were cracked by the earthquake shock so that they leaked.

*Santa Monica, Los Angeles County* (T. H. Moody). — A disturbance was noticed which seemed to be on the front porch, the noise continuing with considerable regularity, and appearing to change from place to place. Then there was other cracking around the house, and finally all was quiet. Nothing moved out of place.

*Los Angeles* (J. D. Hooker). — There was a light shock, then a heavier; then a smart shock which caused windows and doors to rattle. A window curtain swung in and out. A brass ring attached to a cord 15 inches long swung northwest and southeast. At the Weather Bureau station the barometers were observed to swing and rattle against the rings which confined them. The shock was also reported as a slight one at Azusa, Claremont, and Toluca, in Los Angeles County.

*Anaheim, Orange County* (J. F. Walker). — Very few people in Anaheim report having felt a shock at all. It was very slight. No clocks were stopt.

*San Bernardino* (Dr. A. K. Johnson). — The shock was sufficient to stop the town clock at 5<sup>h</sup> 17<sup>m</sup>, and several persons felt the vibrations, but no movable objects were displaced. At 4<sup>h</sup> 30<sup>m</sup> P.M., April 18, a slight oscillation was felt which caused the chandelier to sway. This movement continued for a few seconds, and seemed to be from north-west to southeast.

#### BAY OF SAN FRANCISCO TO THE SAN JOAQUIN VALLEY.

In Contra Costa and Alameda Counties the destructive effects of the earthquake were most manifest in the cities of Berkeley, Oakland, and Alameda, on the east side of the Bay of San Francisco,

*Berkeley* (A. C. Lawson). — A large majority of the brick chimneys were broken or overthrown, and in addition to this several brick buildings had their upper walls thrown down or were otherwise damaged by cracks. The most notable cases of this kind of damage indicative of the intensity of the shock may be briefly mentioned.

At the State Institution for the Deaf, Dumb, and Blind the upper part of the northwest tower of the building, to the north of the central structure, was wrecked by a considerable



A. Berkeley. Institute for Deaf, Dumb, and Blind. South wing, A. O. L.



B. Berkeley. Institute for Deaf, Dumb, and Blind. Herth wing, A. O. L.



A. Berkeley. Barker Block. Shattuck Avenue and Dwight Way. A. O. L.

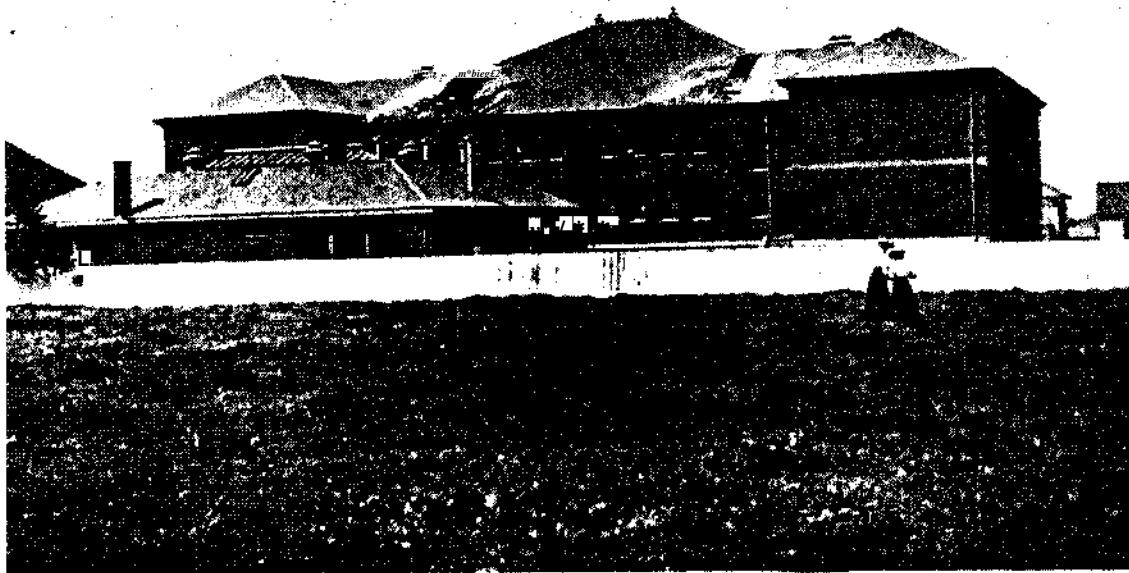

B. Berkeley. High-uliooL A. O. L.

part of the brickwork being thrown out on the northeast and northwest corners of the tower. (Plate 118B.) The upper part of a brick gable in the central building, facing northerly, was thrown southerly, or into the building. The upper part of the tower on the northwest corner of the building to the south of the central structure was demolished. (Plate 118A.) The main clock tower of the Institution, however, suffered no serious damage. The clock, a very unreliable one, stopt at about 5<sup>h</sup> 13<sup>m</sup>. At the High School the walls of the upper story, particularly those facing west, were badly cracked and partly thrown out, so that they had to be taken down. Two large brick chimneys on the east roof collapsed and did much damage to the rooms below. (Plate 119B.)

The Barker Block, at the northwest corner of Shattuck Avenue and Dwight Way, a building veneered in part with brick, had a great deal of the brick facing of the upper part of the building, and much of a strip of tiling above the east wall, thrown down. (Plate 119A.) The upper part of the rear wall of the brick building at the northeast corner of the same streets was thrown down. The north wall of the new Masonic Temple, which was in course of construction at the corner of Shattuck Avenue and Bancroft Way, was thrown to the north and caused the collapse of certain steel girders resting upon it.

The intensity of the earthquake within the city of Berkeley was by no means uniform. There were areas which seemed to a very considerable extent to be immune to the destruction so marked in the throw of chimneys, etc., in neighboring areas. The buildings on the University campus, for example, sustained no serious damage, and there was not a single chimney thrown, altho one or two were cracked. In a belt of the city extending northwesterly from the vicinity of the President's residence on the campus, the damage to chimneys was similarly light. This comparative immunity to destructive shock appears to be associated with the fact that the buildings on the campus, and in the belt to the northwest of it, are practically founded on rock, whereas the portion of the city where chimneys generally fell is on alluvium.

The direction of the fall of chimneys at Berkeley, as elsewhere, was controlled to a large extent by the orientation of the houses. Chimneys usually fell nearly at right angles to the longer side of their cross-section, which was as a rule parallel to one of the walls of the house. Notwithstanding this fact, however, there was a prevailing tendency in the fall of chimneys to the south and east, or in the southeast quadrant. Where chimneys fell to the east, they fell usually a little to the south of the line at right angles to the north and south wall; and where they fell south they fell similarly a little to the east of the normal to the east and west wall. Some square chimneys fell diagonally to the southeast. This was true of a rather massive 4-flue chimney on the writer's house, which fell at the latter end of the shock. In many cases chimneys were dislocated and twisted, without being thrown down. Of 38 chimneys, the rotation of which was noted by observers giving their entire attention to the matter for the time being, 31 were rotated counter-clockwise and 7 were rotated clockwise. In some parts of Berkeley the rocking of the houses was sufficiently violent to make it difficult, and in some cases almost impossible, to stand on the floor without support.

According to the observations of the writer, there were two maxima in the shock, with a lull in the interval, the second being the more violent. The movement appeared to be diagonal to the rectangle of his house, the longer side of which is approximately east and west. The throw of objects was much more to the west than to the east. This was well exemplified by the behavior of objects in the mineralogical museum on the third floor of South Hall. These are upright cases reposing on cabinets of drawers. The shelves, arranged in steps, are orientated north and south approximately, and face both east and West. On the shelves facing east very little was disturbed, while in those facing west



many of the heavier specimens, weighing 20 pounds or more, were projected from the largest, or top shelf, thru the glass doors, and were found strewn on the floor. In no case, however, was the glass of the doors broken. The latter had been forced open at the same moment that the masses of rock had been hurled toward them, thus allowing the missiles to pass thru. Smaller specimens, weighing less than a pound, on the shelves immediately below the top one, were very little disturbed.

*Oakland* (A. C. Lawson). — The destructive effects of the earthquake were much more in evidence in Oakland than in Berkeley, and this is doubtless due in large measure to the much greater number of brick and masonry structures susceptible to this kind of damage. When particular instances are considered, however, it seems probable that the severity of the shock was in reality somewhat greater in Oakland than in Berkeley. Chimneys fell very generally thruout the city; the upper parts of brick walls, gables, and cornices were in many cases thrown down (plate 122B) and cracks in walls were numerous. The underpinning of some few old frame houses caused these structures to collapse. In addition to this damage, which indicates fairly well the prevailing intensity of the shock, there were several cases of more severe destruction which must be noted.

The Prescott school, in course of erection, at the corner of Ninth and Campbell Streets, was rather badly wrecked (plate 121B), as was also the building of the California Flax Works, on the corner of Union and Third Streets, the walls of which gave way, causing the roof to collapse. (Plate 121A.) The susceptibility of this building to destruction was probably due to lack of transverse bracing for the walls, except that supplied by the roof girders. The southeast tower of the First Baptist Church, on Telegraph Avenue, had its upper northeast corner thrown out, and was otherwise wrecked. (Plate 122A.) The east and south gables were both thrown out; but the lower towers at the northeast and southwest corners of the building were comparatively unaffected. The Central Bank building, at the corner of Fourteenth Street and Broadway, had the brickwork of its southwest corner thrown off from the 2 upper stories, and was similarly affected, tho to a less extent, on its northwest corner. (Plate 120A.) The large smoke-stack at the Key Route power generating plant, built on the tidal marsh land, had its upper third thrown off. (Plate 120B.)

Considerable damage was also done to the First Unitarian Church, at the corner of Castro and Fourteenth Streets, and to the Christian Science Church, at Franklin and Seventeenth Streets.

(E. C. Jones.)—There were very few breaks in cast-iron gas-mains. Two of these were caused by impact of heavy debris falling from buildings and poles. One was on Washington Street, where heavy blocks of sandstone fell from the third story and the roof, breaking the main 30 inches below the bituminous rock. Another was at the corner of Fourteenth Street and Broadway, where a transformer fell from a pole, striking the center of a short car rail and bending up both ends. A 3-inch cast-iron main a short distance from this was broken at right angles. On the Twelfth Street dam, a cast-iron pipe was broken and displaced over a foot; while the high pressure steel pipe paralleling it was practically undisturbed. Gas-holders were uninjured, tho much of the water was thrown out of the holder tanks. The only damage to buildings was the destruction of brick gables at Gas Station "B," First and Market Streets.

*Oakland cemeteries* (R. Newcomb). — In the Mountain View Cemetery, which is on a little draw between ridges, the chief damage done was the cracking of the receiving vault, and that was not injured very much.

In St. Mary's Cemetery, on the small ridge to the west, however, many monuments were moved or twisted and several were overthrown. On entering the cemetery from the east, very little damage was observed, but on climbing the ridge more and more was noticed. On the north slope *hss* damage was done, and on level ground farther north

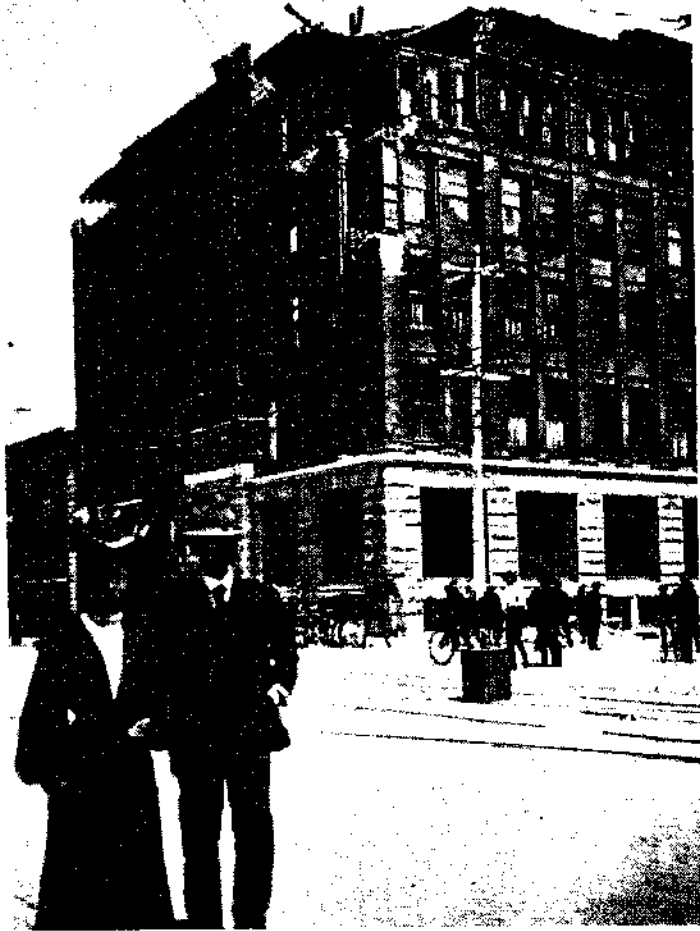

A. Oakland. Central Bank Building. G. K. G.



B. Oakland. Smokestack of power plant, Oakland Traction Company. A. S. E.

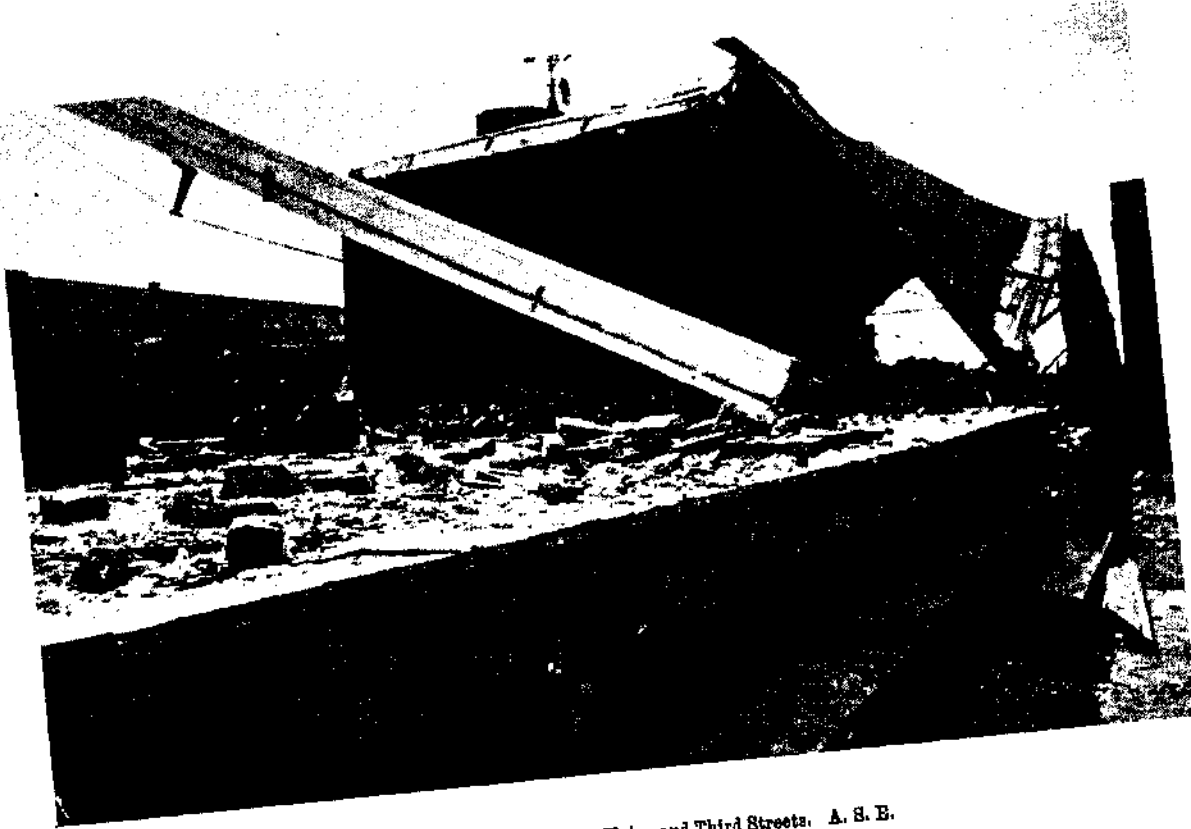

A. Oakland. Flax works, Union and Third Streets. A. S. E.



B. Oakland. Prescott School, Ninth and Campbell Streets. A.S.S.

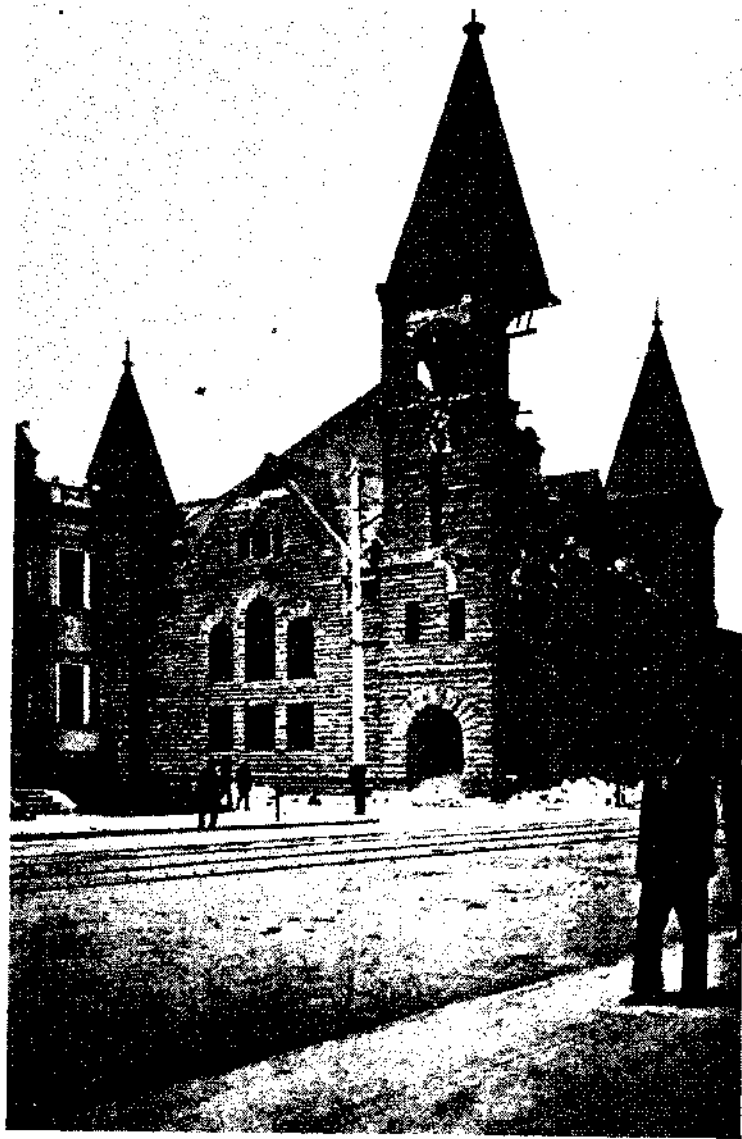

A. Oakland. First Baptist Ohnrch, Telegraph Avenue. & K. G.



B. Oakland. Fourteenth Street, between Washington and Broadway,

absolutely no monuments were affected. Near the top of the ridge many monuments were overturned, and nearly all of them showed twisting or shifting. The result of the shock upon the monuments in this cemetery may be summarily stated as follows:

Fifteen were rotated counter-clockwise, 4 of these thru from  $1^{\circ}$  to  $2^{\circ}$ ; 6 thru  $5^{\circ}$ ; 1 thru  $15^{\circ}$ ; 3 thru from  $5^{\circ}$  to  $8^{\circ}$  with a lateral shift of 1 inch to the east; and 1 thru  $8^{\circ}$  with a lateral shift to the south.

Six were rotated clockwise, 2 of them thru  $25^{\circ}$  to  $30^{\circ}$ ; 1 thru  $15^{\circ}$ ; 1 thru  $10^{\circ}$  with a lateral shift of 6 inches to the south; and 2 thru  $2^{\circ}$  with a shift to the south of 1 inch.

Six fell to the east, 1 to the west, and 1 to the north.

Three were shifted laterally from 0.5 to 1 inch to the east, one 1 inch to the southwest, and one 1 inch to the south.

(B. McGregor.)—Of 12 monuments in Mountain View Cemetery that were disturbed by the earthquake, 10 are rectangular shafts which were simply twisted on their bases, 4 from left to right and 6 from right to left. The other 2 are turned shafts, both of which slid on their bases about 2 inches south. There were a few others displaced.

*Alameda.*—The destruction was confined for the most part to the throw of chimneys and the upper portions of brick walls. A few tanks were also overthrown, and 3 large stacks near Pacific Avenue and Lina Street. Messrs. Pond and McFarland counted 619 fallen chimneys in the city; of these they report that 189 fell to the southwest, 143 to the southeast, 93 to the northwest, 97 to the northeast, 34 to the south, 14 to the north, 25 to the east, and 24 to the west.

The fall of chimneys was evidently determined largely by the orientation of the houses, which have their walls in nearly all cases orientated at right angles to the direction given for the fall. The statistics are quoted not because they have any special significance, but because they indicate how little this class of phenomena contributes to the elucidation of the character of the earth movement, unless each particular case is studied in all its bearings.

With regard to the chimneys which were dislocated and twisted, there appears to be more constancy of result. The same gentlemen counted 61 such chimneys and of these 58 were rotated counter-clockwise and 3 clockwise.

*Southeast of Oakland* (G. Backus and R. P. O. Newcomb).—In the vicinity of High Street about half of the chimneys fell. The most general direction of the fall was to the north and south, altho some fell east and west when the slope of the roof was in that direction. Plastering in the houses was severely cracked, but no foundations nor buildings were damaged to any visible extent. A large smelter chimney in the vicinity was not damaged by the shock.

At Fitchburg about the same state of damage was seen. The chimneys on the old houses were gone. A large school-house with a brick foundation was not injured.

At Elmhurst the windows in the hotels and stores were broken. Most of the chimneys had fallen, one in particular being thrown to the east against the slope of the roof.

At San Leandro half the windows in the stores were broken, and nearly every chimney was down. All loose objects in the houses, such as dishes, etc., were thrown down. The plastering was greatly cracked. The houses were not seriously damaged, and only 2 have been condemned.

At Junction City the shock was about the same as at San Leandro. According to rumor a 3-inch fissure opened up between Junction and San Lorenzo, but this was not seen.

The County Hospital, but a short distance from the Junction, was only slightly damaged. None of the chimneys were thrown over and plastering was not cracked. The Hospital is built on solid ground, and several quarries can be seen in the ground upon which the buildings are situated.

At the San Lorenzo Cemetery, about half the tall monuments were down. Most of these fell to the south, some to the north, and a few to the east and west. Twisting occurs where the south end is thrown east. Almost all the chimneys in this vicinity were down.

At Mills College about half the chimneys were down. A stone building there was badly shattered and will have to be taken down. A brick and concrete library, and the same kind of a bell-tower, were not injured to any great extent, tho a few cracks can be seen here and there. Mills is on rather high ground at the base of the foot-hills.

(J. Keep.)—The floor of my room at Mills College seemed to be boiling. Immense damage was done. In the made ground there was a drop of from 1 foot to several feet. The seismograph registered for a time and then broke. The Science Hall, a stone structure, was badly injured, entailing a loss of \$5,000.

(J. N. Frank.)—In San Leandro objects against the east and west walls of the house were thrown down. Some statues were rotated clockwise. Chimneys were overthrown or broken, and plaster cracked, causing a damage estimated at between \$400 and \$500.

*Mount Eden* (William Gall).—The general direction of the movement was to the north and northeast, but objects fell in all directions. Objects were rotated, some clockwise and some counter-clockwise. A rotary motion was distinctly felt. Brick chimneys were broken and thrown. Furniture was thrown flat. The shock caused consternation among the people and domestic animals. Monuments in the cemetery were overthrown in various directions.

*Decoto* (F. E. Matthes).—No earth movements nor displacements were discovered anywhere along the base of the mountain scarp. The damage to buildings was slight, consisting of broken or twisted chimneys and cracking of plaster in a few houses. A few scattering chimneys escaped destruction, being probably better built than the average. In the stores and saloons articles were thrown down in southerly directions for the most part. Water was observed to splash from a tank a mile north of town, the direction of throw being southeasterly. The consensus of opinion was that the shock had a nearly north-south direction. According to the track-boss, the railroad track suffered no displacements anywhere between Niles and Irvington. The Masonic Home, a large brick structure located on the hillside on solid rock foundations, suffered but little damage. A few insignificant cracks in the brick walls, 2 chimneys broken off, and 2 chimneys cracked constitute the most serious damage. Plaster was cracked in several rooms; no windows were broken.

*Alvarado* (F. E. Matthes).—The Alameda Sugar Company was the chief sufferer. The main buildings of the plant are of wood, substantially constructed, and were not damaged; but the fittings and accessory structures were injured in numerous places. An old lime-kiln showed diagonal cracks in the brickwork; several of the small arches above the fire holes opened and let bricks fall out. A 6-inch cast-iron water-pipe, attached vertically to the main building, broke transversely about 30 feet above the ground. The water in the tanks on the roof splashed so heavily as to raise and break the wooden covers. The water seems to have splashed mostly to the east. The 2 great platforms carrying the molasses tanks, supported by numerous vertical props 10 feet 10 inches high, resting on concrete foundations, fell down altogether; the northern one to the north, the southern one to the south, these directions probably being determined by the original inclination of the supports or the relative efficiency of the bracing. The tanks were all damaged and over 1,000,000 pounds of molasses flowed away. The total weight on the south platform was 1,072,891 pounds. (Plate 115A.) In the engine-room the vertical steam-pipes cracked next to the flanges by the wracking motion of the ceilings thru which they extended. The shock appears to have had a north-south direction, according to the position of the breaks in these pipes.

The mill stands on flat, alluvial ground 100 feet north of Alameda Creek. Along the banks of the latter a large number of cracks extend, roughly parallel with the stream. Considerable masses next to the stream-bed slumped toward the same, leaving gaping cracks 1 to 2 feet wide, and carrying with them small outlying buildings, notably the fire-engine house, which moved bodily, concrete foundation and all, 2 feet south toward the creek. A small railroad trestle southwest of the mill moved 4 inches south on both of its abutments, probably owing to slumping of loose ground on the north side of the creek. A 2-inch water-pipe, laid under the ground some 60 feet north of the creek and almost parallel with the same, shows indications of having been submitted first to tension, causing rupture at one of the joints, then to sudden compression, causing it to be jammed together with violence.

Cracks in the ground may be found as far as 250 feet from the creek. They were nearly all closed at the time of the visit (May 7), but were easily traced by the streaks of bluish-gray sand which has issued from them, together with considerable quantities of water. According to the Chinese cook of the superintendent, the cracks nearest to his dwelling' opened and closed several times in succession during the quake; and large volumes of mud-laden water gushed from them, splashing up some 10 feet in the air at each closing. A large crack of this kind opened under the northwest corner of the dwelling, and the superintendent estimates that fully 500 gallons of water gushed from it, the flow continuing with decreasing volume for about an hour. The fence in front of the house shows that the ground there has been raised into a low hump. The sewer pipe leading west to the creek was detached from the house by a space of 22 inches. A chimney near the northeast corner of the house was thrown to the east with sufficient violence to throw the farthest bricks 35 feet east of the house. The top of the chimney was only 20 feet above the ground originally.

In the roadway south of the mill, water oozed out in a number of places, without the production of visible cracks. The water pipes and hydrants in this vicinity were crushed in several places.

At the Alvarado Water Works the brick buildings suffered considerable damage, the walls cracking in several places. Nothing could be learned regarding the behavior of the wells of this plant. The frame dwelling of the superintendent was damaged by the collapse of its underpinning. A similar fate befell the Alvarado Hotel. Both houses were being put in place at the date of the visit. At the school-house the water-tank fell owing to the collapse of its supports.

Nearly all brick chimneys in the village fell, the directions varying. A few cracks opened across the streets, but these had been filled on the date of the visit. The consensus of opinion was that the shock had a north-south direction.

*Lick Observatory, Mount Hamilton.* — From the reports of astronomers C. D. Perrine, R. G. Aitken, H. K. Palmer, K. Burns, A. M. Hobe, and G. A. Vogt the following observations as to the character and intensity of the shock have been obtained. The principal disturbance was preceded by a tremulous motion variously estimated at from 11 to 15 or 20 seconds. There seemed to be 2 maxima, the first being the stronger (?), according to H. K. P. There was a first secondary maximum about 5 seconds after the beginning, a maximum 11 seconds after the beginning, and another secondary maximum about 15 or 20 seconds after the beginning, according to K. B.

A tremulous motion was felt after the principal disturbance.

"Heavy vibrations were still felt 60 seconds after the first count. Motion was felt for nearly 2 minutes after the first count." C. D. P. "The duration of this tremulous motion was about 30 seconds. Vibrations stopped in the house at the end of that time." K. B.

"Duration between 30 and 35 seconds." A. M. H.

No vertical motion was perceived, nor was any recorded on the Ewing seismograph.

According to C. D. P., the heaviest movement seemed to be nearly east and west; while according to K. B. it was northwest and southeast. On the Ewing seismogram, the north and south component seems to be the most violent, the pen having left the plate for half a revolution of the plate. The east and west vibration was extremely large. The maximum of the east and west movement occurred after the pen of the north and south component left the plate.

A razor strop hanging on a north wall, the only thing free to swing, swung east and west about a foot (double amplitude). A shaving brush which stood up on end and, being round, could fall in any direction, fell west. Things overturned fell east and west.

The shock was severe enough to make windows rattle and doors swing. Book-cases were moved out about an inch from east and west walls, but not from north and south walls. A pendulum clock on a north wall stopt at 5<sup>h</sup> 12<sup>m</sup> 52<sup>s</sup>\*. Not much plaster fell, and only 1 of a dozen or more chimneys was thrown. Some other chimneys, principally those of a 3-story brick house, were cracked and shifted.

The earth-waves were very long, but smooth.

According to K. B., the shock was accompanied by a sound as of the flight of birds.

The water in Smith Creek on the afternoon of the day of the shock was of a light slate color; not yellowish, as after heavy freshets.

"Standing in the doorway and looking out the east window, I could see the walls of the brick house shaking. There seemed to be a great deal of dust in the air in front of the window." H. K. P.

The movement of the east-west component of the Ewing seismograph indicates an intensity corresponding to an acceleration of 400 mm. per sec. per sec. The north and south pen left the plate, owing to the violence of the shock.

*Niles* (R. Crandall).—The town of Niles stands on gravels of the alluvial fan at the mouth of the Niles Canyon, and is about 20 miles due east of the fault at its nearest point. At Niles there were no large buildings, and most of the structures were not strong, but there was no serious damage done to any of them. About 56 per cent of the houses had either terra-cotta chimneys or tin pipes, which are much harder to shake down than those of brick. Of all the chimneys in town, 48 per cent fell; of the brick chimneys 80 per cent fell; of the terra-cotta chimneys only 10 per cent went down.

Most of the houses were not plastered, so no notes could be obtained on that subject. In nearly all of the houses such objects as dishes, bottles, vases, and clocks were thrown from the shelves. Milk and water were spilt from open receptacles in most cases.

A concrete abutment of the bridge across Alameda Creek was cracked. A man out of doors at the time found much difficulty in walking. A 50,000-gallon water-tank fell at the Niles railway station. Similar tanks were thrown down at the stations at Pleasanton, Livermore, and Lathrop. This was due to imperfect construction rather than to the violence of the shock. The tanks were upon cast-iron pillars originally, but when new and larger locomotives were put into service on the railway, it was found necessary to have the water-tanks set higher. This was accomplished by inserting short blocks between the tanks and the tops of the pillars. When the weight of 200 tons was swayed on this sort of a structure, the tank collapsed.

While at Niles, a visit was made to one of the new tunnels of the Western Pacific Railway, which is about 1 mile east of Niles in the Niles Canyon. The tunnel had penetrated about 130 feet into the hillside, but had not yet past thru anything but a sandy clay. During the previous winter the walls at the portal, and also on the inside, had stood without timbering. Since the earthquake it had been impossible to break out more than 4 feet of ground ahead of the timber sets without caving taking place. There had been an apparent movement in the soil which had removed its consistency and made it incoherent. The amount of water present in the tunnel was perceptibly changed. The foreman said



that there was more water since the shock than there had been even in the wettest part of the winter.

*Sunol* (R. Crandall). — Sunol is a small town in the north end of Sunol Valley. The intensity of the earthquake there was of especial interest, because the town lies almost upon the line of the Sunol fault. This fault is the largest one known in the Mount Hamilton range, and has a northwest-southeast trend parallel to that of the San Andreas fault. It was expected that some compensating movement might be found to offset the slip along the San Andreas fault, and this Sunol fault was considered the one most likely to show that compensatory movement. The town stands partly on gravels and partly upon hard sandstone. The gravels are quite firm; much more so than the gravels on which the town of Niles is built. The gravels at Sunol are not thick, and the foundation is much firmer than that at Niles. It was quite apparent that Sunol had not felt the shock as severely as it had been felt at Niles, 6 miles to the west, or at Pleasanton, 6 miles farther east. Only a small percentage of the chimneys fell. Of other objects, few except bottles and vases fell; and a window was broken at the post-office. As there was no movement along the Sunol fault, the intensity at Sunol was less than at Niles, but the fact that it was also less than at Pleasanton shows that the difference must be in the formations underlying the two towns.

(F. E. Matthes.)—Over 75 per cent of the chimneys in Sunol were broken. Some were twisted in a clockwise direction, while others were apparently thrown straight, most of them to the east. Many chimneys were cracked but were still in place. A few windows were broken, notably those of the post-office. The town is on alluvial ground, close to the hills. The depth of alluvium is estimated at the creek-bed to be about 50 feet. The steel bridge southeast of the town was found entirely undamaged. The flume between Sunol and Niles was damaged at a point 2.5 miles below Sunol. A few boards were knocked out of place, but the damage was slight and quickly repaired. The Apperson house, a substantially built structure with strong chimneys, had two of the chimneys twisted and one left intact.

*Verona* (F. E. Matthes). — All the chimneys on the main house of the Hearst residence, 6 in number, were cracked, but none was thrown down. The studio has a long crack running immediately above the projecting beams supporting the roof, along the northeast wall, 18 inches from the eaves. No damage was occasioned to plaster or walls, except in the studio. The chimney of the power-plant, at the foot of the hill, was found cracked. The "cottage," built of wood, suffered no damage. No windows were broken.

*Pleasanton* (R. Crandall). — The town is on a flat valley-floor composed of gravels, apparently the same as those at Sunol, but of a later age. Probably the Sunol gravels washt down from the hills to form a valley-floor. The ground upon which the town is built, then, is similar to that at Niles. The shock was felt quite sharply at Pleasanton, but not so much so as at Niles. Such articles as vases, clocks, and dishes fell in most cases and milk and water were spilt from open vessels. Practically no plaster fell, but houses that were plastered had numerous cracks in the walls.

The intensity, as shown by falling chimneys, was as follows: 30 per cent of all chimneys fell; 48 per cent of the brick chimneys fell; 30 per cent of the chimneys were terra-cotta, but only 3 per cent of these fell; of the brick chimneys which did not fall, 30 per cent were cracked.

(F. E. Matthes.)—About 50 per cent of all brick and tile chimneys in Pleasanton were thrown down. No marked preponderance in any one direction was noted. Nearly every brick building in town was somewhat injured. Cracks in the masonry and the dislodgment of occasional individual bricks in arches above windows and cornices constitute the principal damage. The only stone house, a 2-story saloon, suffered more severely than any of the brick buildings, the walls being badly cracked at the corners and even

partly thrown down at the northwest corner. Wooden houses suffered no damage except the cracking of plaster. No window panes were broken.

Two bridges near Pleasanton were inspected, one north of the town over Arroyo Valley and the other over Arroyo de la Laguna, 1.5 miles west of the town. These bridges rest on concrete abutments, and examination showed that in both cases the concrete had sheared horizontally by the longitudinal oscillations of the superstructure. The cracks were about even with the lower side of the stringers. In the case of the first bridge mentioned, these cracks extended to the wing wall at the south end. A vertical crack was also found near the west corner of the south abutment, running thru the entire height of the structure. A similar crack was also found at the east corner of the north abutment. The disposition of these vertical cracks seems to indicate torsional movements of the bridge, with right-handed rotation. The concrete was of poor quality, being traversed by streaks of coarse gravel alternating with others of finer texture.

Thru the courtesy of F. H. Tibbets and Harold Woods, surveyors for the Pleasanton Hop Company, access was obtained to their records on well borings made in the neighborhood of Pleasanton. Most of these borings did not reach bedrock, but 2 of them did: one near the graveyard south of Pleasanton, which strikes disintegrated shales at a depth of 275 feet; the other 0.75 mile northeast of Pleasanton, just south of the railroad track, which strikes similar material at a depth of 180 feet.

*Livermore* (F. E. Matthes). — Many chimneys were cracked and about 50 per cent thrown down. Several tall brick chimneys in various parts of the town were left intact. Those on brick piers between Livermore and Pleasanton were undamaged. A block of old, weak-looking buildings northeast of the depot suffered no more than a few cracks. Glassware in saloons and bars was thrown to the floor in quantities, in various directions. A heavy water-tank at the depot fell, owing to weakness of supports. The direction of the fall is north, but this is not necessarily indicative of the direction of the shock, as the wooden support probably gave way piecemeal. Concrete bridges about town were unhurt. The town is on alluvium.

An interesting feature appears 0.25 mile north of Meyn's ranch, west of the road leading north from Livermore, about 2 miles north of that place. It is on the summit of a smoothly rounded hill, sloping gently down to an even, peaty meadow traversed by the arroyo of Cayetana Creek. The hill is really one of a number of spurs of the higher land south of the meadow. Its soil is peaty, with many sun cracks due to recent drying. Deep cattle tracks show that it must be quite soft in wet weather, much like the adjoining meadow. The summit of the hill in question was found crowned by a series of concentric deformations, rising stepwise above one another. A number of nearly concentric cracks were found extending northward into a sort of panhandle, along each of which an upward movement of the soil had apparently taken place. The uplift along the 2 principal cracks was found to be 19 and 16 inches, respectively. Along the minor cracks the vertical displacement amounted to an inch or two only. The surface of each step or bench was found to slope inward, and in some places the edge even appeared to have curled inward. The material must have been wet and more or less plastic at the time of the disturbance, but has since dried and hardened, as peaty soil will in dry weather. While the phenomenon is described by many as a "mud flow" or "mud spring," there are no indications whatever of a "flow," strictly speaking. The inward slope of the raised benches suggests the dropping back of the central portions after their upheaval; the scarps remaining, probably, owing to the friction between the opposite walls of the fissures, which prevented the complete return of the adjoining edges to their former level. The concentric arrangement of the cracks seems to indicate a centralized upward thrust, and the small diameter of the entire deformation shows that the effect of the thrust rapidly decreased away from the center. While there is no rock visible, it is quite possible

that the hill has a sort of rock-core, some distance below the surface. The shock felt at Meyn's ranch was not particularly violent and caused no damage to the buildings. (See plate 141A.)

(R. Crandall.)—Geologically, Livermore is on a floor similar to that of Pleasanton, but geographically it is about 6 miles farther east and farther from the San Andreas fault. The shock at Livermore was not severe, and but little real damage was done. A few objects of unstable nature fell, and in the larger number of cases milk and water were spilt from open vessels, but not in all cases.<sup>1</sup> Most of the houses in town were not plastered, but only a few of the plastered houses had the walls cracked, and in only one case was plaster known to have fallen.

An excellent opportunity was afforded to see the effect of the motion upon pendulum clocks. In one jewelry store every such clock stopt, regardless of the direction in which the pendulum swung. One clock which had not been running before the earthquake, was started. Its pendulum swung in a northwest-southeast direction, as in the case of several clocks that stopt. About 5 per cent of the brick chimneys fell, with less than 15 per cent cracked.

A curious phenomenon was observed near Livermore, the explanation of which is not clear. At the Alviso ranch, a little over a mile north of the town, the top of a small hill was broken up at the time of the earthquake. The breaking of the ground did not consist of fissuring along a line, but was in the nature of an uplift of a limited area. There were 3 fairly well marked concentric rings where the ground had broken, the inside ring in each case being forced higher than the outside ring. The effect was similar to that obtained by placing 3 plates of different sizes within each other. The accompanying photograph (plate 141A) shows this feature fairly well. It was said by people in the vicinity that there was mud in the cracks at the time of the earthquake, but there were no evidences of any at the time of the writer's visit several weeks after the shock.<sup>2</sup>

(Elmer G. Still.)—The Southern Pacific Company's 20,000-gallon water-tank fell in a north-northwest direction; tombstones fell in various directions; a hanging lamp was caused to swing counter-clockwise, with the longer diameter of its orbit east and west. Mr. Still was asleep and was awakened by the bed being shaken north and south; the motion after that was in every direction. Water spilt from full tanks mostly on the east and west sides. Mr. Still reports that where the ground was deformed in concentric ridges, as described by Mr. Matthes and Mr. Crandall, there was an alkaline spring years ago.

*Santa Rita*, 3 miles east of Dublin (F. E. Matthes). —A small, flat levee along the east bank of Tassajara Creek, immediately north of the main road, showed several somewhat crescentic cracks along which the ground had slipped down and toward the creek from 1 to 3 inches. These cracks extended farther south, according to local settlers, and cross the road; but this was no longer traceable at the time of the visit. Chimneys had fallen on all the houses, but as they were not of brick the damage was slight. In the grocery store and bar-room articles were thrown in a southerly direction.

*Dublin* (F. E. Matthes). —The damage consisted of a few chimneys broken off, and articles thrown down from shelves and counters. A water-tank 2 miles east fell from its supports, probably owing to the weakness of the latter. Several other tanks in the neighborhood were injured.

*San Ramon* (F. E. Matthes). —Most chimneys had fallen. San Ramon saloon, south of the bridge, slid off its foundations in a northerly direction. The west end moved 3 feet, the east end about 15 inches, being stopt by a fence-post. Several window panes,

<sup>1</sup> This may be contrasted with Pleasanton, where at all the houses visited there was only one where milk was not spilt.

\* A somewhat similar phenomenon was seen on Cahill's ridge in San Matco County, but there was nothing to suggest an explanation.

were broken in the building, and glassware was wrecked in quantities. Neither church nor school-house suffered any damage. The shock was mostly in a north-south direction.

*Danville* (F. E. Matthes).—Most chimneys were cracked or twisted; a few were broken off completely. Glassware in saloons and goods in a grocery store were thrown down in quantities in various directions. Water was observed to splash out from two tanks in the village, in a southerly direction in each case. Water-pipes laid over the surface of the ground at a neighboring ranch were reported to have been thrown out of alinement.

*Walnut Creek* (F. E. Matthes).—About 50 per cent of all chimneys were thrown down. A water-tank at the livery stable fell. Goods in the grocery store were thrown down in quantities. The direction of the shock was not ascertainable. Two barns, weak structures, were moved slightly from their foundations. Plaster in several houses was cracked.

*Clayton* (G. D. Louderback).—At the northern base of Mount Diablo the intensity of the shock was much less than in the alluviated valley-bottom at Concord. No chimneys were thrown down, and no dishes nor glassware were knocked off shelves, but milk in pans was skimmed by the rocking motion. On a hillside above Peach Tree Spring, on the west side of Mount Diablo and very near the contact of the Knoxville shales and the Franciscan, a crack opened in the ground about 30 feet long, in a north and south direction, gaping 4.5 inches.

*Concord* (F. E. Matthes).—Conditions here were much the same as at Walnut Creek. The only brick building, a bank, was cracked. Most of the chimneys were cracked, and about 50 per cent had fallen. A water-tank at the depot was thrown down.

*Martinez* (F. E. Matthes).—Most of the brick buildings here suffered severely; nearly all are more or less cracked, and the stone facing of several was partly demolished. The roofs of the bank and other buildings were wrecked. A small stone house, built of large blocks, was completely ruined, probably owing to vigorous vibrations of an adjoining wooden water-tower near the Alhambra Hotel. The stones started in the east abutment of Main Street bridge. Many window-panes were broken. Most of the chimneys were broken off. The court-house was little injured, except for the pediment above the entrance, where many large stones have been loosened. One of the chimneys of the Bull's Head Oil Works lost a corner; the others were left undamaged. The railroad track east of Martinez, near Bull's Head Oil Works, was thrown 3 inches out of alinement to the north. Many cracks occurred in the embankment on both sides of the track. A series of 5 small transverse waves was found in the embankment about 0.5 mile west of Peyton Station. The distance between crests was about 10 to 15 feet; amplitude estimated at 3 inches. This embankment lies in flat marshy land. A small railroad bridge near Avon Station was thrown 4 inches toward the east abutment, but it had been repaired at the time of the visit.

(W. Stoddard.)—Buildings were loosened in general, the fronts of some falling out. The north and south walls seemed to suffer most. Parts of a large wooden building, particularly the window-sashes, were moved in a southwesterly direction. The wooden props supporting another building were tilted a little toward the southwest. Another building was moved 0.5 inch toward the south. The southern part of the town was damaged more than the northern part. In the cemetery 6 slabs and pillars fell a little east of north; 2 pillars fell to the west; 2 pillars were twisted on their bases and shifted to the west; 1 pillar was tilted to the south immediately next one which fell to the east. A clock at the court-house had its pendulum broken. The pendulum was about 2 feet long. The level of the underground water rose after the shock.

*Cornwall and Black Diamond* (E. S. Larson).—The towns are about 0.5 mile apart, both located on the bay flat and underlain by a tough hardpan. A very few things

were thrown from shelves; one rickety chimney was thrown, and one concrete wall in process of construction fell. Less than half the clocks were stopt, though nearly all sleepers were awakened. Most of the houses are small and have terra-cotta chimneys.

*Antioch* (E. S. Larsen).—Antioch is on the same sort of ground as Cornwall, but there are more brick buildings and more moderate-sized builtlings with brick chimneys. A few chimneys were twisted on their bases, several were thrown entirely and about 25 per cent of them needed repairing after the shock. Out of about 12 brick buildings, the tower of the Catholic church was somewhat damaged, and one rickety old brick building fell. None of the good buildings were damaged. A couple of windows were broken, a few clocks were stopt, and a few things were thrown from shelves. Top-heavy statuettes tipt over. All sleepers were awakened. Things generally moved north and south, or northwest and southeast, which seemed to be the general impression of the direction.

*Bethany, San Joaquin County* (Mr. Schichtman). —The movement was from northeast to southwest, and was sufficient to splash water from a full trough, but not strong enough to overthrow objects.

*Byron Hot Springs, Contra Costa County*. — The springs, some 30 in number, hot and cold, were not affected by the earthquake. One chimney and some plaster were cracked and a picture was thrown from the wall. The shock was considered quite severe, though the damage was slight.

*Tracy* (R. Crandall). — Tracy, in the San Joaquin Valley, lies at the foot of the range separating Livermore Valley from San Joaquin Valley. The shock was not at all severe; in fact it was spoken of by several as being no heavier than the jarring often occasioned by heavy engines starting a loaded train. Very few objects fell, and in only one case was any damage done to a building. This was the cracking of a 2-story brick building which did not appear to be especially well constructed. Only one brick chimney cracked, and none fell; so it would appear that the building cracked because of the poor construction rather than because of the intensity of the earthquake. Milk or water was spilt in only few cases — not over 30 per cent. The water-tank of the Southern Pacific railroad at Tracy fell, as did similar tanks at Livermore, Pleasanton, and Lathrop. The reason for this is explained in the description on a preceding page of the construction of the tank supports at Niles.

*Lathrop* (R. Crandall). — This is a small town upon the floor of the San Joaquin Valley, about 12 miles east of Tracy. The intensity was about the same as at Tracy. There was no appreciable difference in the number of fallen objects or stopt clocks, the main difference being that a considerable number of people were not alarmed enough to get up. One man who was up experienced no difficulty in standing or walking. The general impression is that the shock was slightly lighter than at Tracy,

*Stockton* (R. Crandall). — Stockton is about 10 miles north of Lathrop, but not much farther east. As it is a much larger place, it was easier to see the effects of the earthquake. Not as much detailed work was done in Stockton as at the other places, since it was known that Mr. Edward Hughes was collecting data in that city. The shock was felt with alarm by people in houses and on the ground. The motion was spoken of as being a rolling motion like that felt on board ship. Almost no objects fell, even in houses where there were tall vases and similar brie-à-brae. At one drug store two little vials fell from the shelves; at another even built-up pyramids of various articles for window display were undisturbed. Milk and water were spilt in a very few cases. Splashing of milk up the sides of the pans was noted by a few persons, and the direction was given as northwest and southeast. Many clocks were stopt, but there was nothing consistent in the direction of pendulum motion. All of the big brick buildings were visited, and no damage was found except in an old 2-story building which seemed merely to have

had an old crack widened, due to the settling of the foundation. The City Hall had considerable plaster cracked, but this was due to the swaying of a 50,000-gallon tank on the roof. Three chimneys were cracked, and one was reported to have fallen, but this was not verified. At the houses where the chimneys were cracked, milk was not spilt from open pans, so it is apparent that the chimneys were faulty and not that the earthquake was severe.

(E. Hughes.)—A careful and exhaustive inquiry was made at Stockton by Mr. Edward Hughes, under the direction of Prof. J. C. Branner, and the following notes are contributed by him:

The shock, while strong enough to alarm many of our people, was chiefly notable for the absence of the destructive effects experienced in many less fortunate localities. It began with a gentle trembling motion, which increased slowly for the first 5 or 6 seconds, then rapidly to a maximum of rough jolting shocks lasting perhaps 5 seconds. These were followed by a series of long, smooth vibrations, which gradually decreased in amplitude until no longer perceptible. The effects, as noted by many observers, would indicate that the heavier shocks traveled in a northwest-southeast direction, while the smooth oscillations which marked the latter part of the disturbance ran nearly east-west. The immediate effects, as noted in dwellings, during the shock were the creaking and straining of buildings, the swinging of doors, the rattling of window weights and pictures on the walls, the swinging of chandeliers and drop-lights, and the stopping of clocks. Out of doors, some observers claim to have noticed the swaying of tall buildings and smoke-stacks; and many mention the violent motion of the trees, the branches of which lasht together as if in a storm. Birds frightened from their resting places flew in confusion, and the air was filled with their startled cries.

A careful canvass of the city gives the following results in the way of damages sustained: There were a few small cracks in the arches in the hallways of the county courthouse. It is safe to attribute this to faulty construction rather than to the violence of the shock, as a number of large cracks had opened in various parts of the building soon after it was finished. One water-tank was overturned, the supporting framework being insufficiently braced; this tank fell about 15° east of south.

A large gasometer at the natural gas well on north Commerce Street was slightly damaged. Castings supporting the guide wheels were broken, and the gas tank was slightly twisted to the left so that the guide wheels were thrown off the guides.

In two or three cases in the city, the tops of chimneys fell off. Examination showed that the mortar had never properly united with the bricks, owing probably to their dryness when laid. In several cases houses suffered damage by the spilling of water from attic tanks.

Aside from these cases of relatively insignificant damage, everything gives testimony to the comparative gentleness of the shock. In china stores, where fragile wares were displayed in all sorts of insecure positions, not a piece was displaced or broken. So far as can be learned, no plaster fell anywhere in the city, and there was no breakage of bric-à-brac or china in the dwellings. Observers who watched the minute hands of clocks that were not stopt estimate the duration of the shock at from 30 to 40 seconds.

The heavier shocks were undoubtedly from northwest to southeast. This was shown in several ways. Tanks spilt water in both these directions, and the tank noted above fell nearly to the southeast, although its frame ran approximately east and west, and so offered some resistance to free motion to the southeast. In McCloud's Lake, the waves ran northwest-southeast, breaking highest on the bank and bulkhead in the southeast corner, while the north side was little affected. At the city pumping station on Mormon Channel, a similar effect was noted. Several observers claim to have seen tall buildings and stacks swaying in the direction indicated, and those who were standing were con-

scious of the movement of their own bodies in the same direction. Milk in open vessels left a coating of cream highest on the northwest and southeast sides, although in many cases motion was also shown east and west.

While there is not entire agreement with reference to the east and west vibrations during the latter part of the shock, the larger number of observers plainly felt and saw their effects, and the evidence as to their occurrence seems conclusive. Doors swung east and west; swinging objects, such as drop-lights, hanging baskets, etc., were found either swinging east and west or in circles after the shock, and pictures hung on north and south walls of rooms showed lateral motion during the latter part of it. Tanks in several cases spilt water east and west, although not in such quantities as in the other directions.

The following table indicates the effect of the shock on the 128 clocks concerning which reports were received:

Orientation.	Number of Clocks.	Stopt.	Not Stopt.
Facing west . . .	32	17	15
Facing north . . .	36	18	18
Facing east . . .	27	13	14
Facing south . . .	33	16	17
Total . . .	128	64	64

Clocks with very long or very short pendulums were generally not stopt. Two town clocks were not stopt. One of these, which, through the courtesy of Mr. E. B. Condy, 1 was permitted to examine, is in the tower of the county court-house. Its frame stands northeast and southwest; and its 100-pound pendulum, hung on the northwest side of the frame, swings northeast and southwest, missing the edge of the iron stand about 0.5 inch. A deep scar in the mahogany pendulum bar indicates that during the shock the pendulum swung sharply to the southeast, its bar striking the edge of the iron stand. The weights of the same clock hang in a narrow shaft at the side of the tower. The wire pulley cords which support the weights were found so badly twisted as to interfere with winding the clock a day or two after the earthquake. On the inside of many clock-cases are found scars made by the striking of the pendulums. These scars are deepest on the south side in clocks facing east or west, and on the west side in clocks facing north or south.

Some persons who were outdoors during the shock claim to have heard a dull rumbling sound immediately preceding it. They find it difficult to describe the sound accurately, and in some cases think it may have emanated from nearby buildings. A considerable number of people suffered from nausea and dizziness, with headache, for a time after the shock. With some these disagreeable symptoms persisted all the following day.

*Farmington,, San Joaquin County* (J. F. Gwin). — The house quivered, then the sash weights of the windows began striking back and forth, and a heavy rolling motion was felt which caused open doors to swing back and forth. The clock stopt. The surface of the ground moved in waves like water, and trees moved with the ground.

*Central San Joaquin County* (K. P. Higby), — In Ranges G and 7 E., townships 1 and 2 N., Mount Diablo Meridian and Base line, there were apparently 2 maxima of equal intensity with intervals of a few seconds between. The apparent direction was SW. to NE. No objects nor chimneys were overthrown. The bed shook, and chandeliers, pictures, open doors and shutters were caused to swing. Windows and window weights rattled. The clock diil not stop. Paper on the walls was cracked. The slate roof on a high church tower was cracked. There was scarcely a breath of wind, yet large trees swayed and bent ~~LS~~ if rocked by a terrible gale. Water in the wind-mill tank and in other tanks slept

over, and continued to do so for 5 minutes after the shock. Water was thrown from a swimming tank where the level was 5 feet below the top of the tank; water at one place in the river was thrown over a concrete wall 8 or 9 feet high.

*Modesto* (E. Hughes).—In common with other points in the great interior valley region, Modesto received a very decided shaking up by the earthquake, but suffered practically no damage. The local effects were the stopping of clocks, the swaying of trees, hanging baskets, drop-lights, and chandeliers; and in a few cases the fall of objects from insecure positions in stores and dwellings. Water tanks and troughs, milk pans, etc., spilt part of their contents, and in one or two instances cracks opened in buildings. No one, so far as known, actually timed the duration of the shock in seconds.

The observations of many persons in and near the town indicate that the vibrations were in two principal directions: viz., northwest-southeast and approximately west-east. The heavier shock seems to have been in the first direction, but observers are not in entire agreement on this point. Clocks of larger size were quite generally stopt, no matter in what direction they faced. Several persons report having heard a roaring or rumbling sound, beginning a few seconds before and continuing until the end of the disturbance; and a number of people were affected by symptoms somewhat like seasickness for several hours after it.

The following detailed notes were obtained from citizens of Modesto and vicinity:

(Mr. Schaffer.)—Trees swayed northwest-southeast. "The Swan," a new building with green walls, cracked at the junction of the ceiling with the northeast end wall; also at the junction of the ceiling with the fire-wall running thru the center of the building from northwest to southeast. The cracks in both cases were on the second (the top) floor. The building faces northwest.

(Player's Drug Store.)—Boxes on shelves on the northwest side of the store fell toward the southeast.

(Mr. Swanson.)—Saw water spilt southeast-northwest from the railway tank at the depot.

(Al Fogarty.)—Meat market. Mr. Fogarty ran from the building, and on returning after the shock he found drop-lights and a butchers' scale, suspended by a single wire from the ceiling, swinging in a direction parallel with the street, northwest-southeast.

(Green Brothers.)—Heard a roaring sound just before the shock. Felt the bed swing northwest-southeast. Plaster sifted down from cracks in the ceiling.

(E. E. Woods.)—Mirror hanging from southeast wall fell, on account of breaking of the cord, on its face toward the northwest.

(Mr. Chapman.)—Ranch 5 miles southwest of Modesto. Water trough oriented north-south spilt water from both ends.

(George T. McCabe.)—The bed was standing north-south. The first motion was east-west, the second and maximum motion was northwest-southeast. Trees swayed northwest-southeast. The window sash dropt.

(Mr. Rider.)—Water in the street gutters moved west-east in the first part of the shock; in the second part, northwest-southeast.

(Mr. Schaffer.)—Twenty-one miles southeast of Modesto. The sliding doors on a barn fronting east moved north and south repeatedly during the shock. A water trough a few feet away spilt water east and west.

(Johnson and Ross Store.)—A pile of paint cans stood northwest-southeast. Several cans fell to the northeast.

(G. W. Elsey.)—A tall, open-framed "Mission" clock facing southeast was found after the shock with its pendulum lodged on the top of a cross-bar of the frame. The position of the pendulum indicated a considerable increase in the amplitude of its vibration northeast-southwest in order to allow it to swing high enough to lodge. There were several



similar cases of lodged pendulums in clocks facing in the same direction. Mr. E. Elsey also noted a water-tank spilt east and west, and trees swayed in the same direction. He heard a rumbling sound.

(H. Hintze.)—A water-tank spilt east and west. A hanging lamp swung in the same direction, dropping its chimney to the east. A bed on the porch rolled east and west. He heard a rumbling sound during the shock.

(Editor of the Daily Herald.)—Bed moved northwest-southeast.

(Farmers' and Merchants' Bank.)—The vault is built upon a foundation independent of the rest of the building. The front of the vault, facing southwest, is continuous with a lath and plaster partition which extends to the ceiling. On the left is a wash-room, and on the right an opening into the room at the side and back of the vault. The plaster partition is cracked where it joins the top of the vault and part way down the sides, probably indicating a greater amplitude of motion in the building than in the more solidly constructed vault.

(W. A. Harter.)—At Ceres, 6 miles south of Modesto, a tank spilt north-south.

(W. R. High.)—One mile north of Modesto, a tank spilt north and south during the early part of the shock, and east and west later. Trees swayed north-south.

(Empire Stables.)—Drop-lights swung and water in trough spilt northwest-southeast.

(A. L. Holtham.)—Milk pans on shelf supported by wires spilt milk west. The shock was preceded by a roaring sound,

(Modesto Gas Works.)—Water in the gasometer tanks spilt northwest-southeast. A chandelier in the building hung by a 0.375 inch gas-pipe 12 feet long; after the shock was over this chandelier was swinging northeast-southwest.

(J. T. McNally.)—Station agent saw the railroad water-tank spill northwest-southeast.

(Editor of the News.)—A water-tank belonging to J. Urie, 2.5 miles southwest of Modesto, was overthrown to the west.

The following were the clock records at Modesto:

Orientation.	Number of Clocks.	Stopt.	Not Stopt.
Facing northeast . . .	4	3	1
Facing southeast . . .	12	9	3
Facing southwest . . .	7	5	2
Facing northwest . . .	7	4	3
Total . . . . .	30	21	9

*Ceres, Stanislaus County.*—The shock was felt, but is reported as not seven

*Oakdale, Stanislaus County* (F. G. Koid).—The shock seemed to be in a northeast and southwest direction. In the school-house, a 2-story brick building, timbers lying in a northeast and southwest direction were loosened from the concrete at the ends, but those extending normal to this were not affected. Clocks stopt.

(E. C. Crawford.)—A flag-pole 110 feet high swayed apparently north and south; 2 clocks stopt; water in a tub moved north and south; and a stand lamp seemed to tip slightly north and south until steadied; but no objects were overturned.

*Westley, Stanislaus County* (W. G. Carey).—The town is on adobe soil with gravel at a depth of 20 feet. Furniture and pianos were moved across floors from the walls toward the south, and quite a number of pieces of furniture were toppled over. No chimneys were damaged, but several large water-tanks were demolished. These demolished water-tanks thru the country seem to have been rotated about one-fifth (\*ount<T-t'lot'kwisi\ Cars on the track were moved at least a foot. At the railway depot, a 1,401\*-pound iron wheel was rolled back and forth for a distance of 9 feet northwest and southeast. There

were 2 maxima in the movement of the earth, and the second was the stronger. Some men sleeping on a scow on the river 2 miles east of Westley heard a rumbling sound before any shock was felt, and came out of the scow to see what it was. Then the shock came and the waters rolled and foamed.

**COAST RANGES EAST OF THE RIFT AND SOUTH OF MOUNT HAMILTON, AND THE WEST SIDE OF THE SAN JOAQUIN VALLEY FROM WESTLEY TO DUDLEY.**

In the coast ranges on the east side of the Rift, south of Mount Hamilton, and along the west side of the San Joaquin Valley, settlements are few and widely scattered, so that opportunities for obtaining data as to the distribution of intensity were correspondingly rare. This territory was examined by Mr. G. F. Zoffman, under the direction of Prof. J. C. Brainier, and the results of his observations and of others are embodied in the following report:

*Pacheco Pass Road.* — Starting from Hollister, the county seat of San Benito County, the writer went up the Pacheco Pass road over the Mount Hamilton range to Los Banos, in the San Joaquin Valley. There are but few brick or stone chimneys in this neighborhood, and inquiries were directed to the splashing of milk and the falling of dishes and other movable objects. At the entrance to the canyon thru which the road winds, several houses were visited. Only a few dishes had been broken and milk was thrown only from pans well filled. At Bell's Station no damage was done beyond the loss of milk. High bottles and dishes standing upon shelves were uninjured. The residents say that the vibrations were from east to west, and had a rocking motion. Before the shock a rumble was distinctly heard coming from the west.

At ranch-houses about 5 miles northwest of Bell's Station, and farther up in the mountains, the shock was of considerably less intensity.

*Mountain House.* — The shock was reported as having been very mild; no dishes were thrown from shelves, nor milk splashed from pans. The proprietor states that the earthquake began with a north and south movement which later changed to the east and west. The shock here should be rated at V.

Going down into the valley on the east side of the Pachoco Pass the intensity of the shock perceptibly increased. At a ranch house 7 miles from the pass, nearly all the milk was thrown from pans and all the water from tanks. In a well where the water was 7 feet from the surface, some was thrown out. As noted by one gentleman, water was thrown from a tank, first from north to south, changing later to east and west.

*San Luis Ranch.* — At the east end of the valley, on the San Luis Ranch, Mr. Mills stated that he distinctly felt the vibrations begin from north to south; there was then a lull of a few seconds and then followed a very noticeable east and west movement. The surface of the ground is said to have moved up and down like the waves of the ocean. Thruout this valley, which is made up of gravels deposited on firmer rocks beneath, the shock appears to have been nearly uniform.

*Los Banos.* — On emerging from mountainous districts into the deep alluvial plains of the San Joaquin Valley, the intensity of the shock increased, until at Los Banos it reached a maximum. A count of the chimneys showed 57 per cent (17 out of 30) fallen. All the brick chimneys were damaged, as shown by the accompanying photographs. (Plate 123B, C.) A peculiar feature of the effect upon these structures was that all the damage was on the northeast and southwest sides. Frame buildings were not damaged beyond the falling of plaster, or the throwing down of chimneys. According to the statements of the residents, and the data obtainable, the vibrations were north and south.

*Volta.* — Out of 7 chimneys 6 were thrown down by the shock. The plaster in frame houses was considerably damaged, but none of the buildings was thrown from its

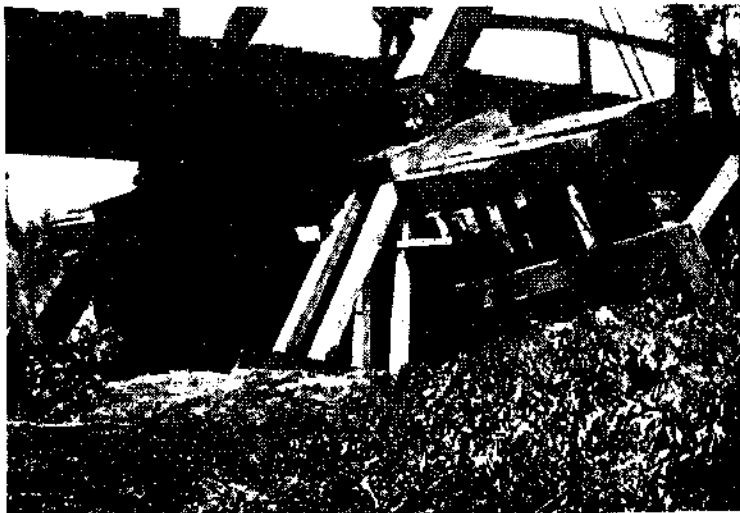

A. Bridge over Salinas Eiver, 4 miles south of Salinas. South terminal pier thrust south 7 feet.  
A. O. L.



B. Los Banos Hotel, W. L.



G. Los Banos Bank, W. L.



D. Oalinga. Z.

foundations. The town had no brick structures. The water of the nearby irrigation canals had, in places, been thrown up on the banks as much as 6 feet above the usual level.

*Newman.* — From Los Banos toward Newman the intensity of the shock appears to have decreased. At the latter place, out of 8 brick buildings only one, just constructed, was thrown down; one was cracked, while the remaining 6 were undamaged beyond the falling of a little plaster. Sixty per cent (36 out of 60) of all the brick chimneys fell, altho little other damage was done to frame houses. A man who saw the 53,000-gallon railroad water-tank fall stated that at the beginning of the shock it began to sway north and south, changing later to east and west, and finally falling toward the west.

*Crow's Landing.* — Out of 18 chimneys only 3, or 16-1 per cent, fell. Considerable water was thrown from the tanks. At a brick oil-pumping station about 4 miles north of Crow's Landing a few cracks were made in the walls. The large oil-tanks and water-tanks were undamaged. People in this neighborhood state that the direction of the vibrations was first from north to south, changing later to east and west. Opinions differ on this point. Many also state that a circular motion was perceptible.

*Grayson and Westley.* — The town of Grayson is on the banks of the San Joaquin River. No damage was done by the earthquake. A very few things were thrown from the shelves, but no chimneys were thrown down. At Westley all the chimneys were found intact. One poorly braced railroad water-tank fell, and one remained standing. The people in this district maintain that the direction of greatest intensity was north and south.

*From Westley to Mount Hamilton.* — From Westley the writer traveled up the Arroyo del Puerto over into San Antonio and Santa Isabel Valleys and up to Mount Hamilton. There are but few houses on the east side of the summit, and but little data was collected. The best was obtained at the Phcenix Quicksilver Mine. Here there are several brick buildings and chimneys, but no damage at all was done to them by the earthquake. In the tunnel there was no shifting of strata. At Mount Hamilton Observatory a couple of chimneys were cracked, but none fell. From Mount Hamilton, the writer went to Paicenes, in San Benito County, thru the Panoche Valley to Mendota, thence to Coalinga, Dudley, Cholame, and Peachtree.

*Paicenes.* — Going from Hollister toward Paicenes the intensity of the earthquake rapidly decreased. At the latter place, which is on the gravels deposited by Tres Pinos Creek, none of the chimneys (3 in number) were damaged, nor were the clocks stopt. Water and milk were thrown from their receptacles in an east and west direction.

*Elkhorn.* — At the Elkhorn roadhouse there were 3 clocks; the one facing north was undisturbed, while the other 2, one facing south and the other east, stopt. No water was thrown from the troughs nor milk from the pans. A few miles northwest of Elkhorn, the milk was thrown from pans on the northwest and southeast sides. The information obtained from the residents in regard to the direction of the vibrations was very contradictory.

*Emmet Post-office.* — At Emmet milk was thrown out in small quantities, but no movable objects were moved or upset. Near the summit between Tres Pinos Creek and the Panoche Valley, the shock was so slight that people did not think of arising. Nothing was thrown over, nor was milk splasht from pans. From Paicenes, where the intensity may be rated at about VI, it gradually decreased up Tres Pinos Creek until at its source the intensity was about IV.

*Panoche Valley.* — This region lies on the east side of the Coast Ranges. At the head of the valley the shock was so slight that some of the inhabitants were not awakened. On going farther down into the lower ground where the soil is deeper, the intensity was slightly greater. At the Panoche store water was thrown from the tank, but no dishes were broken. After leaving Panoche Valley, no definite information was obtainable before arriving at the Chainey Ranch 14 miles west of Mendota. This ranch is on the

plains on the west side of the San Joaquin Valley. The superintendent said that water was thrown out of troughs in a northeast and southwest direction. Movable objects were not disturbed.

*Mendota.* — Mendota is on the low alkali plains on the west side of the San Joaquin River in Fresno County. The intensity of the shock was comparatively light. In the town there were 17 brick chimneys and not one was thrown down. The railroad tank, two-thirds full of water at the time, was shaken down; but it was very insecurely built and only a very small vibration was necessary to overthrow it. Bottles and other unstable articles were not disturbed. The proprietor of one of the hotels, who was up, stated that the first movement was east and west, the second north and south, terminating with a decided twist. People who observed the plains at the time said that they assumed a wave-like appearance, and that trains rose and fell as the undulations past beneath the tracks. They also state that this wave motion was confined to the north and south movement, the east and west motion being more in the nature of a tremor. In the irrigated lands south of Mendota, considerable water was thrown from the canals.

*Mendota to Coalinga.* — At an oil-pumping station 10 miles south of Mendota, there were 10 large tanks; of these the roofs (unsubstantially braced) of 6 caved in, and much oil was thrown over the sides. The brickwork of the furnaces was not cracked. At the ranch-houses, about 6 miles east of the pumping plant, milk and water were thrown from their receptacles, and considerable damage was done by the breaking out of the head gates in the canals. The direction of greatest intensity is said to have been east and west. Many people in this region suffered from a nauseating sensation following the quake.

*Coalinga.* — The tops of a few of the walls of brick buildings were slightly damaged, as shown by the accompanying photograph. (Plate 123D.) A few dishes and bottles were thrown from the shelves, and water was slopt out of the tanks, but none capsized. The direction of greatest intensity of the vibrations was northeast-southwest. At the oil wells no damage was done either to wells or pipe lines. At a pumping station, the brick lining of the furnace was cracked slightly. Considerable oil was thrown from the tanks. In a large reservoir containing No. 10 oil (very heavy), the oil was thrown up 10 inches on the northeast and southwest sides. In a pump having No. 16 grade, the oil was splasht 3 feet up the sides.

*Dudley.* — Going south from Coalinga thru the Kettleman plains, the intensity of the shock apparently decreased, tho there were so few inhabitants that it was impossible to get definite data. At Dudley Station (a farm-house) nothing on the shelves was disturbed nor had milk or water slopt over. It was evident that the earthquake was less intense than at Coalinga. Entering the mountains west of Dudley, there was a further decrease in the intensity.

*Cholame.* — At the east side of the Cholame Valley, the occupants of a ranch-house had not felt the shock. At Cholame Post-office the shock was felt, but very slightly. The postmaster stated that it had a rocking sensation rather than a shaking one. At the Cholame ranch a mud chimney about 7 feet high was left standing out by itself, unharmed, but very insecure.

*Parkfield.*—Near Parkfield there are fissures in the earth, bearing N. 45° W., known to have existed since the first coming of white men. In some places the depressions are 35 feet deep. These fissures were not reopened at the time of the late earthquake.

*SUme Canyon Coal Mine.* — At the coal mine the shock was very noticeable. The fireman on duty the morning of the earthquake stated that the smoke-stacks, 35 feet high and guyed, swung considerably in various directions. No shifting occurred in the strata of the underground workings. It was stated that the movement was northeast and southwest.

*Peachtree.* — As Peachtree was approached, there was a perceptible rise in the intensity. About 2 miles east of the post-office, dishes had been thrown over and milk spilt from pans. At the station itself, however, nothing had been overturned. The region visited between Cholame and Peachtree is in small valleys lying in the mountains on the west side of the Salinas Valley. The soil is nowhere deep.

*Cantua Creek, Fresno County* (S. C. Lillis). — The shock was severely felt in this region, and its direction was southeast-northwest. A series of landslides caused by the earthquake were reported by Mr. Lillis, extending from the northwest corner of T. 18, R. 14 E., M.D.M. to the middle part of T. 15, R. 11 E., a distance of about 23 miles. The features were not at first recognized by Mr. Lillis as landslides, and as they occurred on the east side of the Coast Ranges, on the border of a portion of the San Joaquin Valley, where the intensity was abnormally high, the hypothesis was entertained that there might have been a supplementary fault in that region along the edge of the mountain range. The remarkable alinement of the features lent support to this suggestion. The region was, however, subsequently visited by Prof. G. D. Louderback, in company with Mr. Lillis, and the features reported by the latter were found to be landslides. Professor Louderback furnishes the following note regarding them:

The phenomena reported by Mr. Lillis are several landslides. In each case the effect of the movement can be followed in detail and sharply delimited. The form of the moved body is typically that of the landslide in each case, with the cliff at the upper end curved and concave toward the lower part of the slope. The mass has moved away and downward, leaving in some instances an open space or fissure, partially filled at the present time (May, 1907) by caving. The back cliffs, followed around, gradually pass into lateral planes of movement, which themselves are sometimes gaping on the more elevated side, showing a forward and slightly lateral movement of the mass. (See plate 125B.)

No general fissure, fault, or rift was observed passing thru or near these landslides, altho a careful search was made for such features. I suspected at first that there might be such a rift-line, because the landslides are approximately along one line or belt. This appears, however, to be due to the fact that one particular formation is especially favorable to landsliding, all the slides that I saw along the lower part of the range being associated with a thick reddish-brown shale of a definite stratigraphic horizon (Tejon?). The general structure of the range causes the rocks of any given horizon to outcrop along a line roughly parallel to the range front (approximately northwest-southeast). The landslides all look fresh, and according to Mr. Lillis several of them (and probably all of those under consideration) were caused on April 18, 1906. I made a trip across the hills from the valley to New Idria and noted nothing that appeared to be a recent seismic line.

#### EAST SIDE OF THE SAN JOAQUIN VALLEY SOUTH OF MODESTO AND THE ADJACENT PORTIONS OF THE SIERRA NEVADA.

In this region information regarding the intensity of the shock is rather scant. The shock was in general not sufficiently severe to excite alarm, and people as a rule did not note carefully its effects at the time. Such records as are available indicate that an intensity ranging from VI to V prevailed to the eastern edge of the valley, but that it died out rapidly in the mountains beyond.

*Merced, Merced County.* — Clocks generally were stopt, and hanging objects were caused to swing. One chandelier was observed to swing north and south, and then in a circle.

*Madera, Modern County* (F. E. Smith). — The principal disturbance was preceded by a tremulous motion for about 10 seconds. There were 2 maxima in the principal disturbance, the second being the stronger; and a tremulous movement succeeded it. The apparent direction of the movement was from southeast to northwest, and objects were overturned toward the northwest. The duration of the shock was thought to be 2

minutes. It was severe enough to rattle windows and move doors; to cause the bed to move; to swing hanging objects and stop clocks; and to overthrow ornaments, vases, etc., but not to throw chimneys. In other parts of Madera County the shock was reported from Daulton, Magnet, and Gold, but without sufficient details to afford a clear idea of the intensity of the shock.

*Fresno, Fresno County* (A. C. Obey).—No. VI of the Rossi-Forel scale describes conditions here quite accurately. There was a general awakening of sleepers, oscillation of chandeliers, stopping of clocks, and considerable agitation of trees. Some people ran out of their houses. Water in troughs was spilt out, etc. No damage was done to buildings.

(J. P. Bolton, observer of the U. S. Weather Bureau.)—At the time of the earthquake Mr. Bolton was on the third floor, standing near a window. The time of the shock was 5<sup>h</sup> 13<sup>m</sup> 30<sup>s</sup>. The first shock lasted about 10 seconds. It stopped clocks, swayed buildings, gasoliers, furniture, unlocked doors, window-weights and shutters. There was a short interval of cessation, then a second shock which lasted about 30 seconds, but was less severe than the first. It had a tremulous motion which gradually died away. Each shock developed its greatest intensity near its beginning. The apparent direction was from south to north. The intensity of the first shock was sufficient to sway the stoutest building and disturb its contents without displacing them, and to damage walls slightly. The only sound observed was that caused by the jarring of the building, etc. Many dogs barked vigorously shortly before the first shock.

*Reedley, Fresno County* (John Fairwether).—The shock was north and south; clocks stopped; some plaster was cracked, but no chimneys fell; a front door which was locked was caused to swing open. At Conejo water was sloped out of ditches to the north for 40 feet. At Jameson 2 distinct shocks were felt. At Riverdale, hanging objects were caused to swing. At Kingsbury, a slight shock was felt. At Fowler 3 wells were filled with sand. At Sanger a clock was stopped.

*Visalia, Tulare County* (F. A. Swanger).—A rocking-chair rocked vigorously northeast and southwest, but no shifting of the chair was observed as it rocked. The swell and fall of the earth-wave seemed strong.

(A. M. Doty.)—Four shocks were felt in Visalia, the last being the most pronounced. The town clock and almost all pendulum clocks in the city stopped. The vibration was from north to south. The Delta Building, a two-story brick structure, swayed to the south so perceptibly that it seemed difficult for it to regain its equilibrium. When it did sway back, the tin roof rattled as if some one were pounding on it with a hammer. Practically everybody in Visalia was aroused from sleep by the quake.

*Dinuba, Tidare County* (Miss L. H. Tindall).—There was a smart shock. A clock at the bank stopped. A crack in a brick building was so enlarged that the wall had to be strengthened by rods. A chandelier swayed from south of southwest to north of northeast. Elsewhere in Tulare County shocks were reported at Exter, Kaweah, Orosi, Porterville, and Tulare.

*Bakersfield, Kern County* (A. G. Grant).—The shock was strong enough to rattle windows and doors. Oil sloped out of tanks in the oil-fields 5 miles to the northeast of the city. Some clocks are reported to have stopped.

*Isabella, Kern County* (Stephen Barton).—Mr. E. King, lying in bed, noticed the swinging of a pistol scabbard suspended by a strap directly over his head.

## EAST OF THE SIERRA NEVADA.

DATA COLLECTED BY GEO. D. LOTJDERBACK.

*General note.*—In the towns along the east base of the Sierra Nevada and within, 25 or 30 miles of the base, the shock was distinctly felt, movable objects were seen to swing and heard to bump or rattle, and a very small number of persons were awakened. Farther east the most notable feature of the reports is that wherever the effects of the earthquake were made evident, the physical signs, such as the swinging of suspended objects, etc., were described almost to the exclusion of direct physiological effects. This is apparently at variance with the principles upon which the Rossi-Forel scale is founded, as the first 3 grades of intensity, beginning with the lowest, are based on feeling; the visible disturbance of objects not beginning until grade IV is reached. This may be due entirely or chiefly to the following conditions: Settlements are few and far between and many contain a very small number of inhabitants. When the earthquake occurred, the great majority were asleep, and the few who were up were moving about at active work and were in general not of a sensitive type. It is therefore probably impossible to get satisfactory and correct statistics indicating the distribution of the zones of intensity of the first 3 grades; and the sensible effects of the earthquake probably extended much farther east than reported.

Perhaps the most important of the physical signs reported is the disturbance of smooth water surfaces. In five instances, at three different localities, ditch tenders or irrigators noticed an agitation of quiet water surfaces and that the water lightly splashed against the sides as if from low waves, or as in a vessel of water when it is slightly tilted. As the morning was clear and entirely without wind, it impressed them as peculiar, and the matter was reported when they went to breakfast. The suggestion of one that something peculiar had happened, and of another that it was an earthquake, was each in its place the incitement of sallies of wit at the expense of the reporters. When news of the California earthquake reached these places several hours afterward, the time was found to agree as closely as determinable with the phenomena of the morning. In each of these cases, however, it was reported that no shock was felt. It is suggested that with moderately long waves such surfaces may prove very sensitive indicators of intensities down to the lowest degree on the scale.

The farthest point east at which earthquake effects were reported was Winnemucca, about 340 miles from the fault. A careful search was made for persons who had felt or seen indications of the shock. Only one apparently authentic case was found, and that was of a nurse who had retired a little after 5 o'clock, after a night's work at the County Hospital. She was lying quietly in bed and felt no disturbance whatever; but noticed a hanging lamp swing gently back and forth. Careful inquiry at newspaper offices, the telephone office, the post-office, and of the railroad agent, the weather bureau observer, and many individuals in different parts of the town, failed to discover another observation. This is rather remarkable, because Winnemucca is a town of considerably over 1,000 inhabitants. It is believed that the one definite report obtained is correct; and, as corroborative testimony, may be added the reports from two other localities almost as far east as Winnemucca, in which similar phenomena were described (in one the disturbance of a water surface, in the other a swinging lamp), with the further similarity that no shock was felt.

The elongation of the intensity zones in a northwest-southeast direction is marked. The strongest effects east of the Sierra Nevada were felt with practically the same intensity from at least Sierra Valley to Lone Pine (about 250 miles along the range), while 50 miles east of the Sierra the intensity had materially lessened, and 100 miles east



reports are practically unobtainable. This agrees, of course, with the elongation of the locus of disturbance.

It also appears probable that the sensible effects extended farther along Humboldt Valley, which is practically parallel to the direction of propagation, than along those lines where successive mountain ranges were thrown across the advancing waves, as in the southern Nevada region.

In most cases the direction of vibration was given as north-south, or northwest-southeast; tho in two or three cases north of west to south of east, or east-west, directions were given. Mo.4 of the clocks reported stopt faced north or south; a few faced west.

In a few cases the statement was made that there were two shocks very close together, but most of the observers did not distinguish more than one.

Details for the various localities follow:

*Round Hole*, 70 miles north of Reno (F. McMillan). — A distinct earthquake was felt which lasted several seconds.

*Peavine Mountain*. — A number of ranchers and miners were up at the time of the earthquake, on the north side of Peavine, about 10 or 12 miles northwest of Reno. No one noticed the shock nor any indications of it.

*Reno*. — The shock was distinctly felt by a number of persons. Some were awakened. The great majority knew nothing of it. A good account was given by Mr. Jensen, of the U. S. Weather Bureau. He was in the office to take instrumental readings. The office is on the fourth floor of a rectangular brick building, longer east-west than north-south. He heard some pictures rattle and thought the janitor was getting remarkably industrious downstairs; then he noticed that they were all rattling and surmised that it was an earthquake. His attention was attracted to an electric bulb on a long wire hanging from the ceiling, only a few inches from the west wall. It was swinging so as to hit a metal nipple on a pipe in the wall, thus making quite a noise. The building seemed to shake east-west.

*Olinghouse*. — Many were interviewed, but none had felt the shock. "While there are one or two vague reports, it is probable that no one really felt the effects at this place.

*Wadsworth*. — A canvass failed to elicit any definite account. The postmaster claimed he talked with many people, but knew of none who had observed the shock.

*Ilazen*. — Quite a number of people were interviewed, but no good definite account could be obtained. Most people decidedly had not felt it, and were not sure of any one who had. There were one or two hazy reports of persons who were supposed to have felt or observed it, and one man admitted having noticed a "light shock."

*Virginia City*. — Only a few persons noticed the shock. Mr. D. T. Smith was sleeping on the third floor of a rectangular building that stands east and west. He woke up and felt a movement of the building. An electric globe suspended by a cord from the ceiling (about 5 feet) swayed about 1.5 inches with an elliptical movement, the major axis a little north of west. No one else in the building noticed it.

*Wabuxka*. — A few are reported as feeling a "jar." No one noticed the direction.

*Yeringtm*. — A few felt the shock. It was light and described as north-south. One person in bed but awake said the bed rocked and a curtain swayed north-south, producing a sort of dizzy sensation.

*Fallon*. — Throe persons were found who claim to have been awakened; they were all women and light sleepers. One (Mrs. K W. Black) awokp and heard u noise which she thought was tho rattling of the window weights. Another (Mrs. I. H. Kent) awoke hearing a noise like tho rattling of a window. She also noticed a bird cage and a hanging plant swing in a north-south direction, the distance from tho point of suspension to the coitcr of gravity of those being about 5 feet. Others in tho same houses noticed nothing.

It is reported that ditch tenders on the Government irrigation canal noticed a disturbance of the water surface, and light splashing of the water as if by low waves or rocking. They reported it at camp in the morning some hours before news of the California earthquake arrived. Direct testimony is lacking on this point, tho the report was generally believed at the Reclamation Service Offices at Fallon and Hazen.

*Fairview.* — Reports from several sources are to the effect that no shock was felt, and no distinct evidence of the earthquake was observed.

*Lovelock.* — Several clocks are said to have stopt, but some of the reports, tho direct, seem to be unreliable. Several persons were awakened. One (Mr. Dawkins, principal of the Lovelock School) felt a slight shaking; others heard a noise as if a person were knocking, or the blinds or ventilators had rattled. One feared the powder house had "gone up." (F. J. Gunnell, A. G. Bosk, C. H. Valentine.) The clock in the hotel is said to have stopt. It hangs on an east-west wall and faces south. The station clock, in a similar position, was also reported stopt. On several ranches 8 to 12 miles south of Lovelock the irrigators noticed waves or splashing in ditches or canals, and reported the same at breakfast that morning. Ditches extend north-south; the slope is very low, almost horizontal, and the water surface smooth and quiet. (John Sullivan, irrigator for Lovelock Commercial Co.; Peter Naker, rancher; James Jensen, son of rancher, etc.) One report speaks of a lamp swinging. Those who saw the effects on water surfaces, and others in general, felt no shock.

*Mill City.* — The station agent said he had no positive indications of the earthquake and no one felt it.

*Unionville.* — Tom Powell, a rancher 4 miles south of Unionville, says that his wife woke him about daylight, and called his attention to the lamp swinging. They felt no shaking. They noticed later that a fine dust from the adobe walls had crumbled down on to the surface of the cream.

*Winnemucca.* — A rather thoro canvass of the town was made because it is the farthest east at which any report of the earthquake was made. Only one definite account was obtained, and it is believed to be reliable. Mrs. Sloane, nurse at the County Hospital, had been on night duty and had just retired. As she lay quietly in bed, she noticed a hanging lamp with pendant glass prisms swing. It swayed, in her judgment, nearly 3 inches, not far from east and west. She called her husband's attention to it and suggested that it might be due to an earthquake. It continued swinging some time. No shock was felt, nor was swaying of the building noticed. The railroad agent, the weather bureau observer, who was up at the time, the postmaster, the employe's in the telephone office, the people in both of the newspaper offices, and a number of other people in various parts of town, all said that they had felt no shock and had seen no effects of it, and knew of no one who had, except a few who had heard of the case of Mrs. Sloane. Another person, reported by one or two as having felt the shock, was interviewed, but claimed that she had felt no shock and that the report must have been started as a joke.

*Hawthorne.* — Two clocks are said to have stopt. Mrs. Taylor described the shock as a tremor, as if a pet dog were scratching and passing the bed, followed by a distinct movement toward the north and back toward the south. Mr. Brodigan, in the second story of the court-house, felt quite a shake.

*Mina.* — The shock was distinctly felt by some. In the store it was said that the building distinctly swayed, the dishes and tinware on the shelves making some slight rattling. In the telegraph office the clock stopt. The shock was very slight and felt by only a few,

*Bodlc* (E. B. Brooks).—The shock was perceptible; some clocks stopt. It was noticed by occupants in some 2-story building?, but was not generally felt.

*Mono Lake.* — A slight shock was felt on the west side of the lake.

*Candelaria* (Charles N. Platt, weather observer). — He did not feel the shock and knew nothing about it until the newspaper report came.

*Laws*. — Ten or more persons noticed the shock, which was slight. W. M. Richards stated that there were 2 shocks, one almost immediately after the other. The first was a gentle rocking motion, the second small jerks. The total duration was about half a minute.

*Tonopah*. — Several communications were to the effect that no one had noticed any indications of the earthquake.

*Goldfield*. — Several reports were received to the effect that no shock was noticed. A report was in circulation that the springs had changed somewhat in their flow, but the Superintendent of the Western Reclamation Company (F. A. Thompson), who keeps a very close watch of the wells and springs, says there was no change at all in the flow nor any other indication of an earthquake.

*Eureka* (Clay Simms).—A slight shock was felt, the movement being from west to east. It seemed to last for about a second. It made hanging objects swing, but did not stop clocks.

*Bishop* (W. A. Chalfant). — The shock was strong enough to waken many persons asleep. Large clocks in the jewelers' stores were stopt. The length of the vibration was unusual, but was not timed. The earthquake was not felt as a sharp shock, but rather as a long and not severe rolling motion. Doors, windows, window weights, etc., were shaken, and hanging objects, such as incandescent bulbs, swayed back and forth thru an arc of 12 to 18 inches, double amplitude. No damage whatever was done to property. Doors on the north and south sides of buildings seemed to have been affected most. In one instance a box of dry goods was moved about 3 inches. Out-of-doors the rumble of the shock was noted by a few persons.

*Independence* (Mrs. E. M. Brooks). —Some clocks were stopt and windows rattled, but few felt any shock.

*Lone Pine*. — A number of clocks were stopt, all facing north or south. The shock was noticed by only a few persons. According to one description, there were 2 shocks a few seconds apart. It seemed like a rolling movement, and a hanging lamp was noticed swinging north-south. Trees shook.

*Keeler*. — Only 2 or 3 persons noticed the shock. It was only slightly perceptible.

In gathering information concerning the California earthquake of the morning of April 18, as felt in the Western Nevada region, two other closely succeeding shocks were brought to light, one of which had much stronger local effects than the greater but more distinct earthquake.

*The Earthquake of April 19, 1906, about 2<sup>h</sup> 5<sup>m</sup> P. M. :*

This shock was mentioned by so few persons that I was at first inclined to consider it imaginary. It was reported, however, by reliable persons not known to each other in three different towns. The most definite accounts are as follows:

*Reno* (Miss Lowers). — Observer on the third floor of the Agricultural Building at the University, in the photographic laboratory; felt a very distinct shock, but did not remember the direction of movement.

*Olinghouse* (Miss Norris). —The person reporting and her sister were sitting in the house and felt a distinct shock. Fearing it was the forerunner of a larger earthquake, they ran outside.

*Hazen*. — A shock not generally felt was noted distinctly by Mrs. MacGregor, at the Reclamation Service headquarters.

*The Earthquake of April 19, 1906, 8<sup>h</sup> 15<sup>ra</sup> to 8<sup>h</sup> 30<sup>m</sup> P.M.* (Intensity, IV-V.) — This earthquake was distinctly felt along the east slope of the Virginia range and the valley land directly east and not far north or south of Lat. 39° 31'. Wherever reported it was

much stronger than the shake produced by the California earthquake of the previous day. It was generally felt at Hazen, Wadsworth, Olinghouse, and neighboring places where it is hard to find any one that noticed any effects of the great quake. In Hazen it rattled windows, made gas jets and lamps swing, and doors swing on hinges. The railroad station clock is said to have stopt. At Wadsworth, it made the windows rattle and caused some fear, owing to reports of the San Francisco disaster. One person describes it as a quick sharp shock like a blast. At Olinghouse also it was felt as a sharp shock — one called it a quiver — and caused windows to rattle. It was felt as far east as Brown's Station. It was apparently not felt at Fallon, tho it was distinctly felt 12 miles west at Carson Dam. In the Reclamation Service camp at Fernley it was quite strong, as felt on the ground in the tent. Judging from its areal distribution, it is suggested that this earthquake is related to the fault along the east base of the Virginia Range. The rough time estimates vary from 8 to 9 o'clock, but in cases where the time was noted more particularly, the variation is between 8<sup>h</sup> 15<sup>m</sup> and 8<sup>h</sup> 30<sup>m</sup>. The vibration was apparently northwest-southeast, or north-south, at Hazen. At Fernley (a short distance south of Wadsworth) it was described as northeast-southwest.

## OBSERVATIONS OF J. A. REID.

Professor J. A. Reid, who has been engaged for some time past in a geological study of the fault-zone of the eastern flank of the Sierra Nevada, made an examination of various faults with which he was familiar, with the view of ascertaining whether or not evidence could be found of movement at the time of the earthquake. No such evidence was, however, found. He also made an examination of several hot springs along the base of the mountains, to ascertain what changes, if any, had been caused by the shock. The only ones which seem to have been affected are the Steamboat Springs, 12 miles south of Reno.

In addition to making these examinations, Professor Reid obtained some valuable information regarding the intensity of the shock, as given in his notes which follow:

At Reno people were not generally awakened. There were no exact records of the time, direction, or intensity of the shock. The movement was large, but slow, and of long duration — probably about 40 seconds in total. The clock of ex-meteorological observer S. B. Doten stopt. An extension incandescent electric light, on an 8-foot cord, so arranged that it could swing only north-south, was set swinging thru a 3-foot arc. This was on the first floor of an old wooden house, and gives some indication of the magnitude of motion and time of oscillation. Mr. Doten was awakened by the shock and counted 20 seconds of lesser motion after he was fully conscious. No noise was heard. Another observer was awakened, and saw a 4-foot light and cord swing about 18 inches nearly east-northeast and west-southwest. At the University of Nevada similar lights were set swinging with a large east-west component of motion.

At Steamboat Springs the shock was felt as a long, gentle swing. A second shock, seemingly as hard as the first, was felt the second or third night after. At the Rocky Hill Mine, in the foot-hills of the Virginia Range, midway between Steamboat Springs and Washoe, the shock was not felt by men at work, and loose rock in the main tunnel was not dislodged.

At other points between Steamboat Springs and Carson, as at Lakeview, Washoe, and Lewer's Ranch, the earthquake was felt as a long, gentle swing. At Bowers Mansion, a few feet from the steep granite escarpment of the Sierra Nevada, all sleepers were awakened by the shock, which appeared to have greater intensity near the harder, more elastic rocks than in the loose valley deposits. The same result occurred in Carson Valley, south of Carson. At and near Genoa, directly at the base of the 4,000-foot scarp of the Sierra, the shock generally awoke sleepers, and trees were noticed to swing as in

a wind. A few miles eastward, however, in the river-laid valley deposits, the shock was felt by very few persons.

In the town of Gardnerville, some few miles east of Genoa, a number of people complained of a feeling of nausea while eating breakfast at the time of the earthquake, but felt no motion. In all cases the shock felt was characterized by long, gentle motion; in no cases was sharp movement experienced.

At Virginia City, about 6 miles east of the Rocky Hill mine, the shock was felt by very few people, and they were in the tops of the higher buildings. Around Dayton and nearby towns no reports came of persons feeling the earthquake. The Virginia Range seems not to have been greatly shaken. At Carson, the most reliable and abundant data were obtained. Mr. C. W. Friend, the well-known meteorological observer, obtained a seismograph record of the shock,<sup>1</sup> which was by far the heaviest ever recorded by him, the stylus of the instrument swinging entirely off the plate. Yet the motion was so gentle and of such a long period that sleepers were not generally awakened. The time of oscillation was not determined, but was described as being like the swinging of a hammock. The seismograph record is peculiar in that the stylus appears nearly to have retraced its course over one large curve. Carson lies about 3 miles east of the steep rise of the Sierra Nevada, with a deep deposit of river wash between. At the southwest, however, a low hill of schistose rocks just enters the town limits. This structure may play a considerable part in the peculiar motion of the earth here in this and other earthquakes.

At Paradise Valley, north of Winnemucca, the earthquake was felt by the few people awake or moving at that early hour. A rancher who happened to be near a small pond noticed an unusual agitation of the water, and supposed an earthquake to be the cause. The time was subsequently found to correspond with that of the shock, as reported elsewhere. No motion was felt, however.

## EXPERIMENTS WITH A SHAKING MACHINE.

BY F. J. ROGERS.

The investigation described below was undertaken with the hope of offering some explanation, based directly on experiment, of the greater destructiveness of earthquakes in regions where the foundations of structures are supported by more or less soft ground than where these foundations are based on solid rock.

As an earthquake consists in the actual shaking of the earth's crust it would seem, upon first thought, that the more rigid the foundation the more destructive would be the effects of the earthquake upon the structures so supported. This is in general not true, however.

In conversation with Dr. Branner, the great desirability of some experiments on this subject was suggested to the writer. In the first experiment which promised any interesting results a bucket of molding sand was poured out upon a board about 20 x 30 inches. The board was shaken in a horizontal direction through an amplitude of 2 or 3 centimeters, by means of a small motor. When the sand was moderately wet, the amplitude of vibration of the top of the mound was greater than the amplitude of vibration of the board on which the sand rested. This result is contrary to what I should have expected. When the result of this preliminary experiment was reported to Dr. Branner some time afterwards, he was greatly interested and urged the writer to carry on a series of similar experiments on a larger scale, the same to form a part of the report of the Earthquake Investigation Commission. As a result the apparatus described

---

<sup>1</sup> This seismogram is referred to in another part of the report.

below was designed and was later constructed by the Mechanical Engineering Department of Stanford University.

In designing a shaking apparatus to imitate an earthquake, certain conflicting conditions must be taken into consideration. It would seem that the apparatus ought to be on as large a scale as possible, but if it is on a large scale, it must needs be very expensive. If the linear dimensions are increased in any ratio, say trebled, the volume, weight, strength, and power to operate must be increased in the *cube* of this ratio; hence if the linear dimensions are trebled, these quantities must be increased 27-fold. Moreover, it is obviously impossible, at any cost, even to approach the scale on which nature acts. With these considerations in view it was decided that the scale of the apparatus should be as small as is consistent with obtaining results from which general conclusions might be drawn.

Earthquake motions are exceedingly complex, but it was not thought worth while to imitate this complexity, but rather to confine the shaking motion to a simple to-and-fro horizontal motion in one direction.

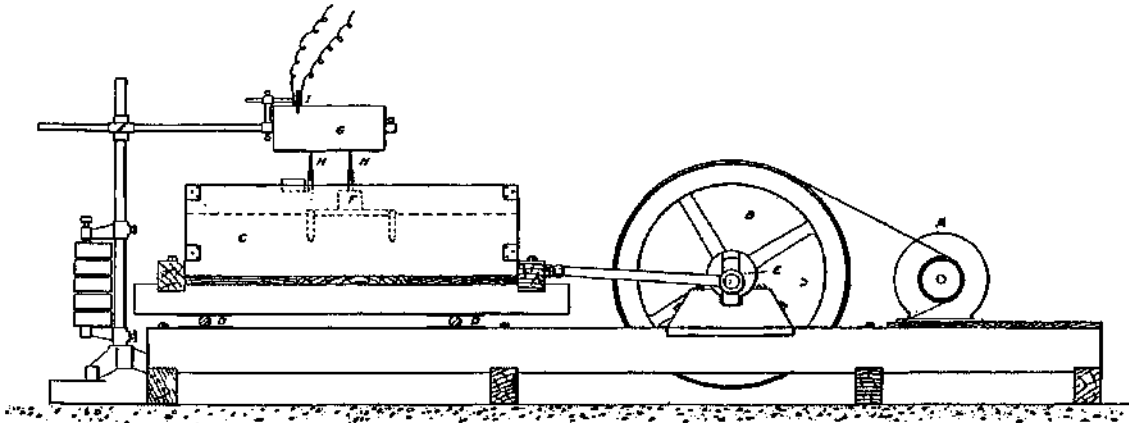

FIG. 60. — Diagram of construction of apparatus used in experiments

A side elevation of the apparatus as finally constructed is shown in fig. 60. *A* is a direct current motor, *B* is a balance wheel weighing about 75 kg. The connecting rod, instead of being driven by an eccentric, is driven by an adjustable crank, *E*, which allows the stroke to be adjusted to any value up to 10 cm. *C* is the car, whose internal dimensions are 100 x 86 x 30 cm. The car is carried on steel rollers, *D, D*, 4 cm. in diameter. The car, balance wheel, and motor were all mounted on a heavy framework securely bolted together. The drum *G* was mounted on an entirely independent support. A paper wrapt around the drum received traces representing, (1) the motion of the car, (2) the motion of a block *F* set in the material on the car, and (3) the beats of an electromagnet *I*, electrically connected to a seconds pendulum. (The pencil actuated by the electromagnet was on the same side of the drum as the other tracing pencils, instead of being on the opposite side, as shown in the figure.) The block *F* was 30 cm. square and was furnished with side pieces running 6 cm. down into the sand, so that its motion was necessarily the same as the material immediately under and surrounding it.

The experiment consisted in loading the car and then shaking it by means of the motor, with various amplitudes and frequencies. While the car was being shaken, the drum was rotated by hand, and the relative motion of the car and the block embedded in the load was determined by measuring the traces on the paper wrapt around the drum.

The material with which the car was loaded was limited almost exclusively to ordi-

nary building sand from a creek bed, combined with various amounts of water. Some experiments were made with gravel, but lack of time and the necessity of completing the work for publication in the report of the Earthquake Investigation Commission prevented more extensive experiments.

When the car was loaded with moderately dry sand containing 10 per cent of its weight of water or less, it was plain to direct observation that the sand was moving almost perfectly with the car, so long as the frequency was less than  $2\frac{1}{2}$  double vibrations per second. However, if the sand was wet locally by pouring water upon it, it was also very evident that the wet sand did not move at the same rate as the nearby dry sand. In the first place, the amplitude of vibration of the wet sand was greater than that of the dry sand; and in the second place, the reversal of motion was much quicker in the case of the former than of the latter. In the region between the wet and the dry sand, the difference in the relative motions of the two, causes the surface to be broken up by crevasses which open and close periodically. This breaking up of the surface is quite irregular, varying from moment to moment.

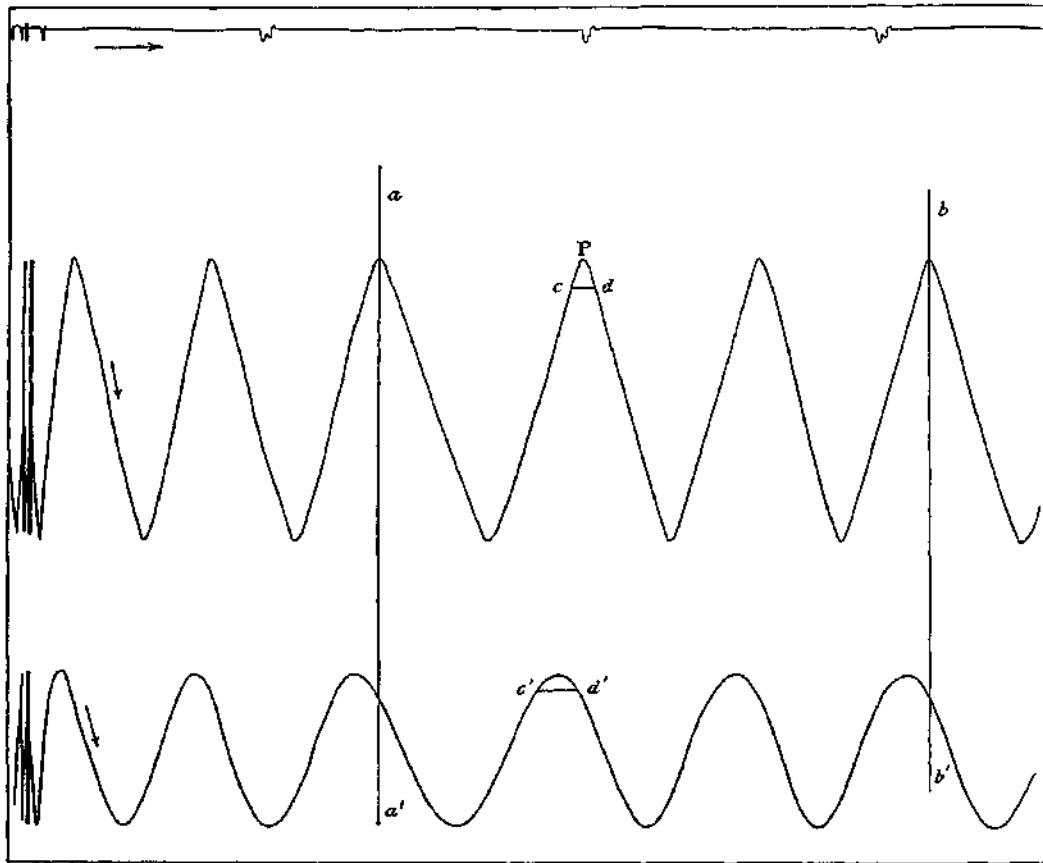

FIG. 61. —Curves obtained on recording drum. Reduced about half.

For a precise determination of the relative motion of the car and the sand with which it is loaded, it is necessary to measure the curves traced on the revolving drum described above. The method of doing this will be best illustrated by taking a particular case. Fig. 61 is a copy of one of the curves obtained on the drum. The lower sinuous curve is the trace made by the pencil attached to the car; the middle zigzag line is the trace made by the pencil attached to the block embedded in the sand; the upper line is the trace of the electromagnet beating seconds. In this particular case the sand contained

all the water that it would hold, so that it was very soft, almost semi-fluid. The amount of water was determined by weighing a portion of the wet sand and then weighing it again after it had been thoroly dried. In this case the material contained 20 per cent of water to 80 per cent of sand.

The traces show at a glance that the amplitude of the motion of the sand was much greater than that of the box. By reference to the transverse lines *aaf* and *W*, it is obvious that the motion of the sand lags behind the motion of the box—in this case about one-sixth of a complete period. Finally, the difference in the character of the two motions is shown by the sine curve in one case, and the zigzag line in the other case. The sine curve shows that the car has a simple harmonic or pendulum motion, as must necessarily be the case on account of the way in which it is shaken. On the contrary, the block embedded in the sand moves with an approximately uniform velocity until the end of the "stroke," when its motion is very quickly reversed; after which it again moves with uniform velocity until its motion is again quickly reversed. The acceleration at the instant the motion is reversed is a proper measure of the quickness of reversal. This acceleration can not be measured, but the average acceleration during a short interval of time while the motion is being reversed can be determined. If *cd* and *c?d'* (see fig. 6) are drawn at corresponding parts of the curves, then the lengths of these lines are proportional to the times required for corresponding changes in the two motions. The square of the ratio of these two times, divided into the ratio of the two amplitudes, gives the ratio of the two accelerations during the motion *cPd*. The closer *cd* is taken to *P* the greater this ratio becomes. In the present case, in which *cd* is drawn at one-tenth of the amplitude from *P*, the ratio of the two accelerations is about 3. As moving forces are always proportional to accelerations, the bearing of this result on the destructiveness of earthquakes is evident.

The data obtained from fig. 61 may be presented as follows: Load shaken, sand 80, water 20. Depth of sand, 22 centimeters. Frequency of motion, 1.7 double vibrations per second. Amplitude of car, 4.5 centimeters. Amplitude of block in sand 8.5 centimeters. Lag of block, one-sixth period. Ratio of accelerations at reversal, 3 or greater.

A large number of experiments were made with a load of wet sand having the above composition. Results similar to the above were obtained whenever the frequency of the motion was rather small. However, when the frequency of the motion was considerably increased, or when the ratio of water to sand was changed, the results obtained were quite different. In general the less water the sand contains the more nearly does it move with the car. The accompanying tables contain results from a large number of experiments in which the composition of the load and the frequency of motion was varied.

The data from these tables are plotted in figs. 62 and 63. In all cases the number of complete or double vibrations per second is plotted along the *rc*-axis, while the amplitude of motion of the block embedded in the sand is plotted along the *2*-axis. The points representing observations do not fall upon smooth curves, but this is hardly to be expected from the nature of the experiment.

The data as illustrated by the plots show that when the load consists of sand and water in the ratio 4 to 1, for low frequencies, the sand oscillates through a much greater amplitude than the car, and that the amplitude rapidly decreases as the frequency increases and becomes quite small for frequencies of 3 or 4 per second. On the contrary, when the load contains only 15 per cent of water, it moves with the car, for low frequencies, and the amplitude increases with the frequency. The results actually obtained are subject to a large probable error, but there can be no doubt about the decreasing amplitude with increasing frequency in one case and the opposite result in the other case. When the sand contains about 15 per cent of water, it seems to be more adhesive and more capable of packing into a relatively compact mass. In this respect it is distinguished



Results of experiments in which composition of load and frequency of motion was varied.

WATER: SAND = 20:80			WATER : SAND = 17:83			WATER : SAND = 15:85		
Frequency	Amplitude in Centimeters		Frequency	Amplitude in Centimeters		Frequency	Amplitude in Centimeters	
	Car	Block		Car	Block		Car	Block
.5	6.1	9.5	.6	6.0	7.9	.9	6.1	6.3
.75	6.1	9.7	1.0	6.0	8.5	1.7	6.2	7.4
1.0	6.1	9.5	1.4	6.0	9.0	2.6	6.4	8.1
1.3	6.1	9.2	1.6	6.1	9.3	3.3	6.5	8.4
1.5	6.1	7.3	2.3	6.1	9.5	3.6	6.3	8.0
2.0	6.2	5.9	2.4	6.1	7.5			
3.2	6.3	1.9	2.8	6.1	8.0	1.0	3.2	3.4
3.5	6.4	.3	3.6	6.4	4.4	1.2	3.3	3.8
			3.8	6.4	4.3	1.8	3.3	4.4
.83	4.0	7.4				2.7	3.4	4.7
1.0	4.3	7.2	.85	3.3	5.2	3.2	3.4	5.1
1.3	4.3	6.5	1.5	3.3	5.3	3.9	3.4	5.2
2.1	4.3	3.5	2.5	3.3	5.4	4.0	3.4	5.0
3.0	4.3	2.4	3.1	3.4	4.3	4.6	3.6	5.5
4.0	4.5	1.2	4.1	3.5	2.2			

WATER : SAND = :12:88.			WATER : SAND = 10:90   Two layers			DRT GRAVEL.			WET GRAVEL.		
Frequency	Amplitude in Centimeters		Fre-quency	Amplitude in Centimeters		Fre-quency	Amplitude in Centimeters		Fre-quency	Amplitude in Centimeters	
	Car	Block		Car	Block		Car	Block		Car	Block
1.8	6.2	6.3	1.4	4.4	4.5	2.5	4.6	4.6	1.9	4.6	4.6
2.5	6.4	6.4	2.0	4.7	6.3	2.8	4.6	4.9	2.7	4.8	4.9
2.8	6.2	6.4	2.3	4.7	6.4	3.2	4.7	5.2	3.2	4.8	5.3
3.2	6.7	7.0	2.5	4.7	6.5	3.3	4.8	5.4	3.4	4.7	5.8
			2.6	4.6	6.0	3.5	4.8	5.4	3.3	4.7	5.9
1.0	3.1	3.1	2.6	4.8	5.5	3.7	4.8	5.0	3.4	4.5	5.7
1.8	3.2	3.2	3.2	4.7	3.8	3.8	4.9	5.2	3.4	4.7	5.8
3.3	3.3	3.4	3.4		3.8	3.9	4.8	5.3			
3.8	3.4	3.7									
4.0	3.4	3.8									
4.2	3.5	3.8									

on the one hand from the soft and semi-fluid condition with a larger per cent of water, and on the other hand from a more friable condition with a smaller per cent of water. When the load contained only 12 per cent of water, the motion of the block embedded in the sand was very nearly the same as that of the car. For the data given, the motion of the block for the higher frequencies was slightly but unmistakably greater than the motion of the car. At another time, when there was about the same per cent of water in the sand, the motion of the sand was just as unmistakably less than that of the car, altho by only a small amount. In the latter case the sand was probably somewhat drier and less adhesive than in the former case. In still another experiment, in which the sand was very much drier, containing probably less than 5 per cent of water, the amplitude of the motion of the block was distinctly greater than that of the car, at least for frequencies of 3 per second. Of course this does not refer to the motion of the loose sand on top. The motion of a layer 1 or 2 cm. deep of such loose, dry material was always much less than the motion of the car.

In the above discussion we have been solely concerned with the motion of the block embedded in the sand in the middle of the car. The sand on the bottom and near the ends of the car has but little relative motion with respect to the car. A board thrust downward into the sand showed by its motion that the relative motion of the sand with

respect to the car increased from the bottom to the top. That the whole upper surface of sand in the car did not move together with the same speed was quite plain to direct observation. When the sand was very soft and wet, it rose and fell near the ends in the form of incipient waves, which, however, were not propagated away from the ends, three-

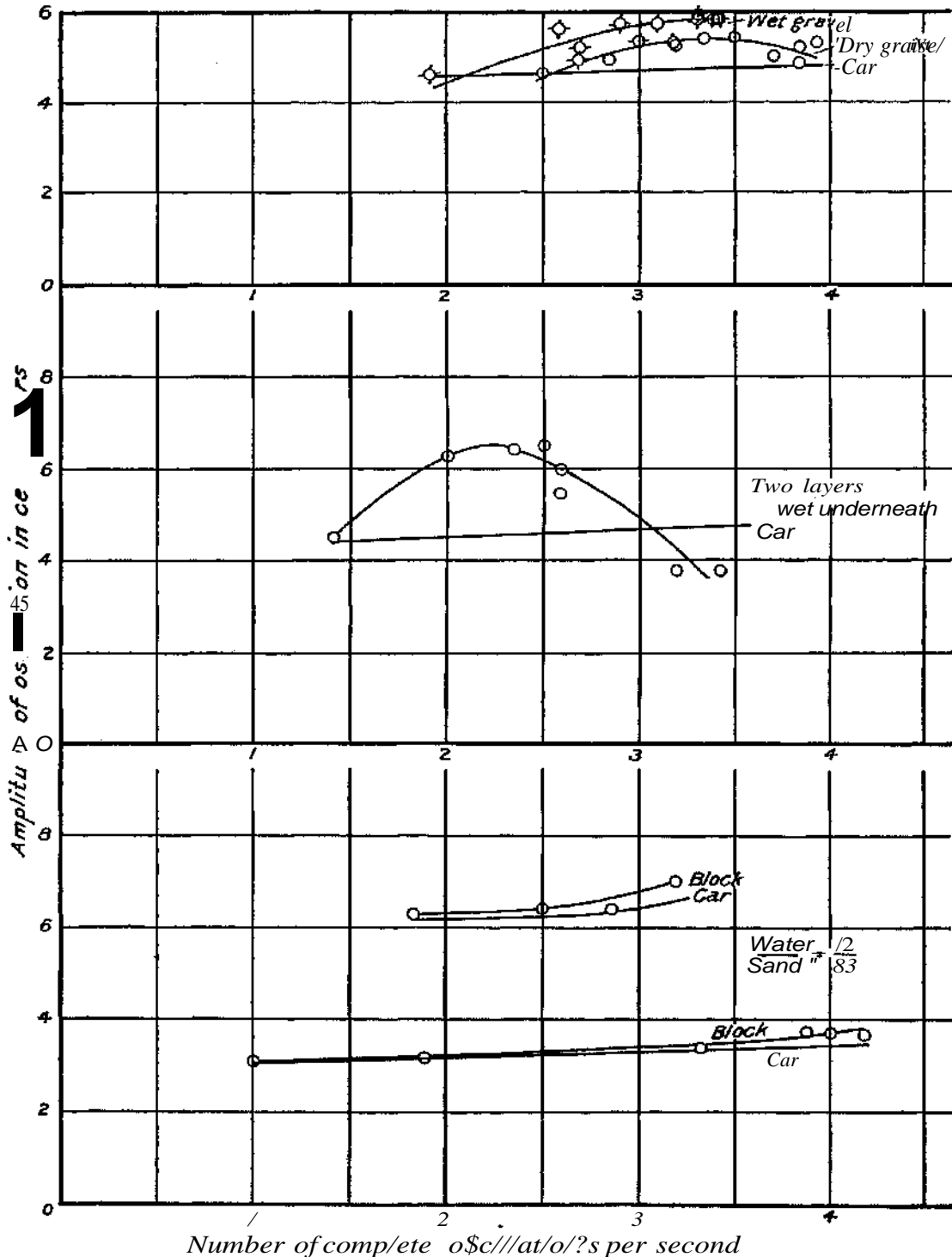

FIG. 62. — Graphic representation of result\*.

quarters of the surface remaining practically level during the vibration of the car. When the sand contained less water, the surface midway between the ends and the middle of the car was badly broken up by crevasses and ridges at right angles to the direction of motion.

It doubtless frequently happens in river valleys, coastal plains, or "made land" that a very soft water-soaked subsoil is covered with a crust of more solid ground. This condition of affairs was imitated on a small scale. A lower layer 13 cm. thick of very wet sand containing 20 per cent of water was covered by a piece of oilcloth, and upon this was placed a layer 12 cm. thick of much drier sand containing 10 per cent of water, and tamped into as compact a condition as possible. The block carrying the tracing pencil was embedded in this upper layer. If the whole load of sand had been like the top layer, it would have oscillated almost perfectly with the car. No such result was obtained with the two layers. When the car was shaken, it was apparent that there was still considerable freedom of motion in the lower layer. The upper layer moved as though it were floating on a semi-fluid mass. It rose and fell at the ends, and this motion extended to the middle, causing the block to rock back and forth, a result which was not obtained when the car contained a load of uniform consistency. The to-and-fro motion of the block was considerably greater than that of the car, for frequencies of 2 or 3 per second. For frequencies greater than 3, the amplitude of the block was less than that of the car. The results of this experiment are given in the tables on p. 330, while a plot of the same is included in fig. 62. The results, however, do not do justice to the possible destructiveness of such a motion. The rocking motion of the upper layer, as well as the violent manner in which it was broken up into fissures and ridges, seems to show that the destructive effect of the shaking motion of a semi-fluid mass may be increased when it is confined by a superincumbent layer of much more solid and compact material.

In the last experiment with the shaking machine, the car was loaded with coarse gravel. The gravel consisted of water-worn pebbles of all sizes up to 2 inches in diameter. It contained no clay nor sand to bind the gravel together. When this load of dry gravel was shaken, the block embedded in the gravel moved with the same amplitude as the car until the frequency reached 3 double vibrations per second. With higher frequencies the amplitude of the block was somewhat greater. Considerable water was then poured into the car, and it was again shaken with various frequencies. The results were similar to those obtained with the dry gravel, except that the relative motion of the gravel with respect to the car was nearly twice as great as in the case of the dry gravel. The data for these experiments are given in the table, while a plot of the same is given in fig. 62.

A consideration of the meager and more or less erratic data described above suggests various questions and criticisms. It has already been explained why more extensive experiments involving other materials were not undertaken. The erratic nature of the experimental data is not due to the method of experimentation employed, but to the uncertain and varying condition of the material with which the car was loaded. If, in the beginning of a series of experiments, the composition of the load was thoroly uniform, this was no proof that it remained so. A few moments of shaking sufficed to change to a greater or less extent this uniformity. When the material contained a large percentage of water, continued shaking caused the material close up to the ends of the car to pack and become somewhat drier; this was also true, tho to a much less extent, of the middle portion. The portion midway between the ends and the middle, where the relative motion of contiguous portions of the load was the greatest (thus causing fissures and ridges to develop), noticeably increased its content of water. This development of non-uniformity in the consistency and composition of the load is a sufficient explanation of the irregularity of the results obtained.

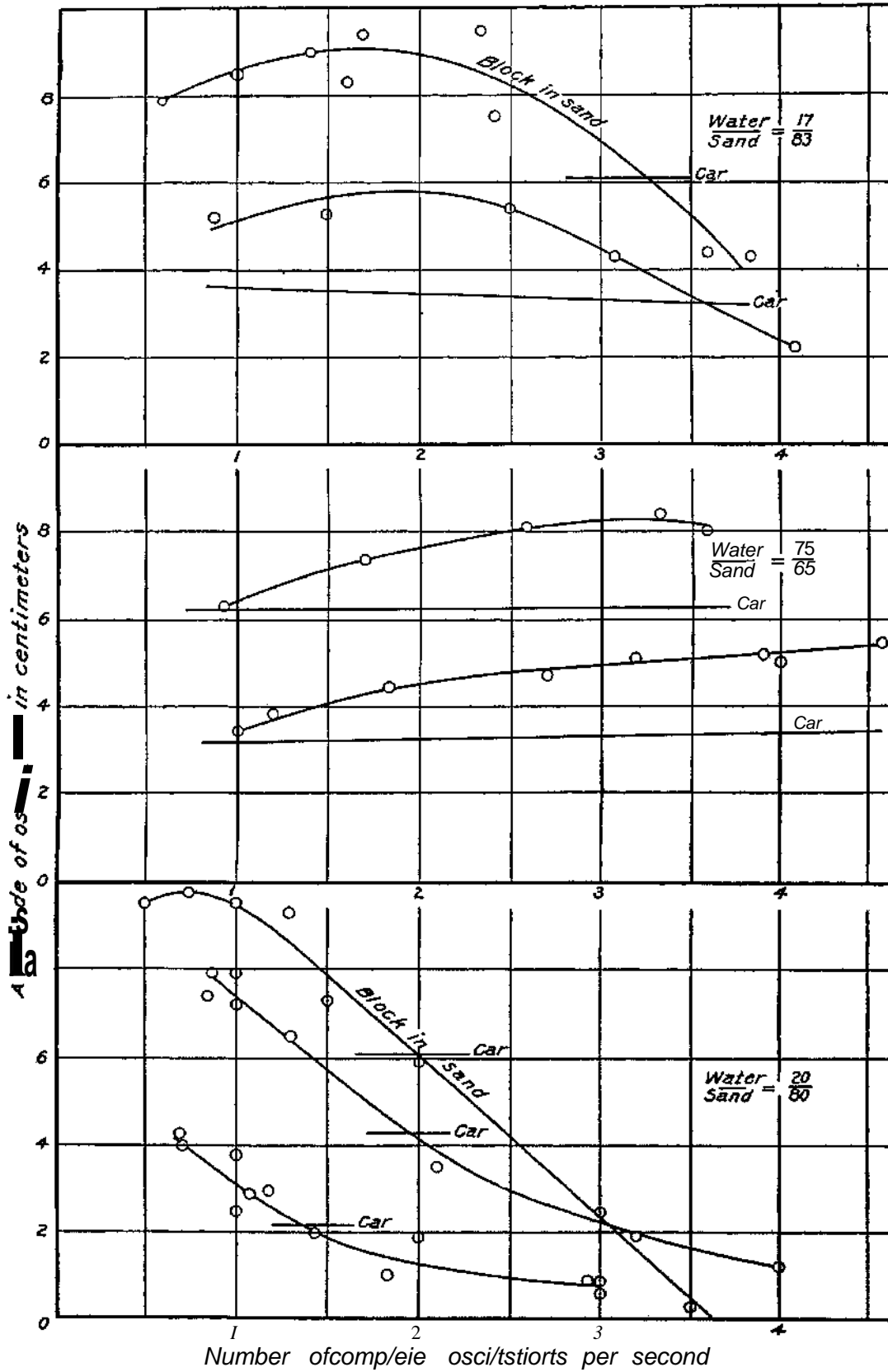

FIG. 63. — Graphic representation of results.

With regard to the scale on which the experiment was performed, the question naturally occurs: Would similar results have been obtained if the car were very much larger? One can not be certain, but it seems that such would have been the case if the frequency and amplitude of the car's motion were the same. Several experiments were performed with a depth of 15 cm. and 25 cm., and the results were substantially the same. The car was also divided by partitions running at right angles to the direction of motion, making a compartment of only half the length. The results tabulated below show that, at least in this case, the motion of the block embedded in the sand was not greatly affected by the presence of the partitions.

Length of car between partitions in cm.	101	49	101	101	49	49	101
Frequency in double vibrations per sec.	2.2	2.25	2.3	2.1	2.4	2.15	2.25
Amplitude of car in cm.	7.5	7.6	7.7	7.6	7.5	7.5	7.5
Amplitude of block in sand in cm.	11.9	9.3	11.3	10.8	10.8	11.4	11.8

In the experiment just described the material used contained 20 per cent water; with less water the partitions would doubtless have a greater effect in restricting the motion. It is also probable that with a larger car the relative motion of car and load would have been greater.

Another question which is likely to occur is: Does the solid or semi-fluid mass with which the car is loaded have a free period of its own which is comparable with the vibrations impressed upon it by the to-and-fro motion of the car? To elucidate this matter, the car was partially filled with water and the free period of gravitational waves determined experimentally. The frequency of such waves was found to be 1.06. However, the load, instead of being like water, was in all cases exceedingly viscous and plastic. This condition would in any case decrease the natural vibration frequency of the load, and in the present case the viscosity was so great that the load could not possibly have any vibration independently of the oscillatory motion of the car.

Finally the question may be asked: What is the explanation of the fact that the load on the car (or the major part of it) oscillates thru a greater amplitude than the car which causes the motion? At present I have no comprehensive explanation of this fact. It undoubtedly depends upon the inertia of the load, combined with the greater or less freedom with which it yields to impressed forces. The load in the car is set into motion by two sets of forces: (1) On account of the motion of the bottom of the car a tangential force is exerted on the bottom of the load and this is transmitted upwards by the rigidity of the load, or, expressed otherwise, by the mutual friction of successive layers of the load. (2) On account of the advancing motion of the end of the car the load receives a thrust which is transmitted thru the material by its resistance to compression. Sometimes one of these sets of forces is of greater importance, and sometimes the other. One would be apt to think the end thrust was of the greater importance, but this is certainly not always the case, for when the load consists of a *mound* not resting against either end of the car, the block embedded in the top of the mound may oscillate with a much greater amplitude than the car. (This was experimentally demonstrated.) In this case there can be no end thrust whatever. In some cases the end thrust may be more effective than the tangential force; this is probably the case when the frequency of motion is rather high.

To those interested in seismology the important question is: How do these experiments help to explain the greater destructiveness of earthquakes in regions where foundations are in alluvial soil than where foundations rest directly upon rocky strata? To pass from experiments upon a box containing half a ton of soil to the destructive effects of an earthquake is certainly a great leap. In taking such a step, one is very likely to make mistakes. However, it seems to me beyond question that a soft, semi-fluid mass of

soil, containing a large amount of water and surrounded or partially surrounded by solid strata, will not oscillate with the same motion as the surrounding strata. Moreover, in the case of the frequencies ordinarily occurring in earthquake motion, the amplitude of the oscillation of such a semi-fluid mass is likely to be greater than that of the surrounding solid strata; also the reversal of motion or the acceleration during reversal is likely to be greater than in the case of solid strata. Finally the greater relative motion of such a soft or semi-fluid mass is not prevented by overlying strata of drier and more compact material.

#### REVIEW OF THE DISTRIBUTION OF APPARENT INTENSITY.

In the preceding pages, all the data significant of the distribution of the intensity of the shock of April 18, 1906, have been set forth in such detail as seemed to be warranted in a statement of fact. The general conclusions drawn from the data are represented graphically upon the intensity map No. 23. It is proposed here, however, to call attention to some of the more interesting and instructive phases of the distribution of intensity, and briefly to discuss their significance.

It is to be noted, in the first place, that the region over which the disturbance was felt, extending from the Pacific Coast to Central Nevada, and from southern Oregon to southern California, is one of varied physiography. In a consideration of the relation of the physiographic features to the distribution of intensity, it will be necessary to distinguish only two classes of features; viz., (1) the mountain and hill slopes, generally underlain by firm rocks and veneered for the most part with a thin mantle of regolith and soil; arid (2) the valley-bottoms usually underlain by a relatively great depth of infilled alluvium in a little coherent condition, and for the most part saturated with ground-water.

The color bands on the map, indicating the gradation of intensity, show very considerable irregularities, or departures from the smooth curves which might reasonably be expected to obtain as the expression of such gradation of absorption of energy in homogeneous materials. To some extent such irregularities may be ascribed to the known lack of homogeneity in the firm elastic rocks of which the earth's crust is chiefly composed. But the irregularities referred to are too great to permit us to regard such lack of homogeneity in the underlying elastic rocks as an important factor in determining them. The irregularities are clearly related to the distribution of the valley lands.

#### GENERAL DISPOSITION OF THE ISOSEISMALS.

If now, before entering upon a consideration of these irregularities, we endeavor to ignore them, and so obtain a general conspectus of the color bands representing the gradation of intensity, the following features come out fairly clearly:

1. On the northeast side of the fault-trace, the zones of equal gradation of intensity show a tendency to belly out to the northeastward, opposite the middle portion of the fault-trace. This tendency is most pronounced in the grades from VII to II of the Rossi-Forel scale, and is apparent in all grades below IX.

The irregularities above referred to, associated with the distribution of valley lands, confuse<sup>1</sup> somewhat the perception of this tendency, but do not detract from its reality.

2. As a partial statement of the same general fact, the color zones become distinctly narrower, and their boundaries converge, as they approach the coast north of Eureka. This feature of the distribution of intensity clearly suggests that the isaseismal curves close in and swing around the end of the fault, and that there is, therefore, no indication of a submarine prolongation of the fault beyond its known extent on the mainland in Humboldt County.

3. The zones of equal gradation from IX to V of the scale are narrower at the southern end of the fault-trace than at the northern end, and they close around the end much more closely. This fact is suggestive of less depth of disturbance at the southern end of the fault. But the general disposition in the south of the zones ranging from V to II is not essentially dissimilar to those in the north.

4. The disposition of the isoseismal curves along the coastal territory between Point Arena and Shelter Cove indicates that the trace of the fault on the sea-floor lies but a few miles off shore, and that its course partakes of the nature of a very obtuse sigmoid curve, approximately parallel to the trend of the coast. It follows from this inference that the fault observed in Humboldt County is continuous with that extending from the vicinity of Point Arena southeastward. No facts have come to light which weaken this conclusion, altho all the facts have been diligently sought for.

5. On the southwest side of the fault, the territory upon which it has been possible to trace the isoseismals, particularly those ranging above VI, is very much smaller than on the northeast side. In so far as the territory available is representative of the entire southwestern crustal block, it appears, chiefly from the isoseismals covering portions of San Mateo, Santa Cruz, San Benito, and Monterey Counties, that the intensity diminished much more rapidly to the southwest than it did to the northeast. This interesting fact suggests that, of the two crustal blocks differentially displaced on the fault, the southwest block was perhaps the more passive. It may, however, indicate that the apparent intensity, as interpreted from effects on structures and objects, is a function of the character of the underlying rocks; since on the southwest side of the fault-trace there are extensive areas of highly elastic granitic rocks, while on the northeast side of the fault-trace these granitic rocks are deeply buried by sedimentary formations and appear nowhere at the surface west of the Sierra Nevada.

6. The zones of equal gradation of intensity, ranging from X to VII, are fairly evenly spaced, tho broadening with diminishing intensity; from VII to VI the zone is notably broader, particularly in the northern portion of the region affected; and from VI to II the broadening of the zones is very marked.

#### RELATION OF APPARENT INTENSITY TO VALLEYS.

The generalizations above set forth are independent of the irregularities in the isoseismal curves associated with the valleys. We may now inquire into the relationship which obtains between the valleys and the distribution of apparent intensity.

The most northerly locality where this relationship appears is on the flood plain of the Eel River, near the coast, in Humboldt County. The lower part of the Eel River Valley has been carved by stream erosion out of a synclinal trough of Pliocene strata having a thickness of over a mile. The syncline is flanked by older and much harder sandstones which are probably of Franciscan age. On the south of the valley these older sandstones constitute a bold mountain ridge, steep with terraces, which terminates in Cape Mendocino. The north side of the ridge has an east and west trend, and the Pliocene strata extend well up on its flanks. There is no suggestion of a fault on this side of the ridge, the trend being determined by the axis of the synclinal fold. The other side of the flood plain has a less regular northwest-southeast trend, converging upon the south side in the vicinity of Rio Dell. The flood plain is thus bounded by a wide trumpet-shaped but asymmetric contour terminating in lagoons and sand beaches south of Eureka. The depth of the alluvium of the flood plain is not known, but the features of the region suggest that it is undergoing subsidence and the alluvium may be several hundred feet thick. On this flood plain the apparent intensity was notably higher than on the surrounding slopes. This is shown by the extent of destruction in Fernald and other towns situated upon it, and by the rupturing and deformation of the

alluvium of the flood plain itself, particularly in its lower part near the sea, and by the lesser destruction in the surrounding higher country. The data regarding the intensity on the high ridge to the south are scant, owing to the fewness of habitations, but on the Pliocene terrane on the northeast side of the flood plain, there was a distinct drop in the degree of destruction, altho this terrane consists largely of strata which are only partially indurated and but little coherent.

The apparent intensity of the lower part of the Eel River flood plain grades from X to IX, tho in general nearer IX than X. It is surrounded by a belt of country where the intensity grades from IX to VIII. This belt has a width of a few miles on the Pliocene terrane to the northeast of the flood plain, and probably scarcely extends to the harder Franciscan rocks of the ridge to the south. The facts thus necessitate the recognition on the intensity map of an area of high intensity, including a range from X to VIII, in the midst of a region where the prevailing intensity ranges only from VIII to VII. This, as will be seen in what follows, is typical of all the more important alluviated valleys of the Coast Ranges, and indicates clearly that the apparent intensity for such situations is a function of the underlying formations.

On the more limited flood plain of the Mattole River at Petrolia, the destructive effects were even more intense than at Ferndale, and in marked contrast to those apparent in the few scattered houses on the rocky upland. But little can be inferred from this contrast, since Petrolia is situated on the projection of the fault-trace, and only a few miles beyond the most northerly point to which it has been mapped.

The town of Willets is at the headwaters of a branch of the Eel River on a flat alluviated valley-bottom several miles in extent. The situation and character of the valley are such as to suggest that it is a filled-in lake basin. The ground-water below the valley-floor stands within a few feet of the surface. The town is 26 miles from the coast at Mendocino City, and not less than 30 miles from the fault-trace; yet the apparent intensity was not less than IX of the scale, or equal to that which prevails on the hard rocks in the zone, the distal border of which is usually not more than 6 miles from the fault-trace and often much less. Between Willets and the coast the intensity had diminished from X in the vicinity of the fault-trace to less than VII. This rapid rise from less than VII in the territory immediately to the west, to IX on the valley-floor, with no evidence of other factors intervening, and no evidence of similarly high intensity on the rocky slopes surrounding the valley, again indicates that the apparent intensity is a function of the character of the valley-floor.

A similar condition prevails in the valley in which Tjkiah is situated, 20 miles to the south of Ukiah. The physiographic features of the valley are described by Mr. George McGowan in his report describing the effects of the earthquake at Ukiah. The town is about 27 miles from the fault-trace, and in this interval the intensity had diminished from X to less than VII. In Ukiah, which is on the old flood plain of the Russian River, near the middle of the valley-floor, the intensity rose to between IX and VIII. Here again, there can be little doubt as to the influence of the underlying formations upon the destructive effects of the shock. This conclusion is supported by the time at which the shock was felt. Ukiah is one of the few places where satisfactory time observations were obtained.

At the International Latitude Observatory, Dr. Townley reports that he was awakened by the shock and lookt at his watch, finding the time (corrected) to be 5<sup>h</sup> 12<sup>m</sup> 30", and he is of the opinion that the shock commenced at 5<sup>k</sup> 12" 17<sup>s</sup>. This accords fairly well with the time the shock was due at Ukiah, and affords no suggestion that the local high apparent intensity may have been due to a local earthquake.

Another valley area of high intensity is on the west side of Clear Lake, extending from Kcls'yville to Upper Lake. Lakeport, in the central portion of this area is 30



miles distant from the fault, with 2 mountain crests intervening. In this interval the intensity had diminished from X to less than VII, but at Lakeport and Upper Lake it rose to IX. The topographical and geological maps of the Clear Lake district, published by Becker/ show that Lakeport and Kelseyville are on an alluvial plain, the underlying deposits of which are of Quaternary age; and the same conditions prevail at Upper Lake. Between this area of alluvium and Bartlett Springs, on rocky ground, 10 miles to the east of Upper Lake, the intensity dropt to VI. At Lower Lake, situated on Tejon sandstone, the intensity had similarly dropt to VI; and these intensities are about the normal for the distances at which Bartlett Springs and Kelseyville lie from the fault along the coast. At Highland Springs, the intensity was between VII and VI, which is also about the normal for its distance from the fault. It thus appears that the high apparent intensity was confined to the alluvial or recent lake deposits of the area about Lakeport. These facts indicate that the high apparent intensity for this area was probably not due to a local earthquake, coincident or nearly so with the main shock, but that the destructive action of the latter was locally augmented by conditions inherent in the underlying incoherent deposits. For if there had been a local dislocation, its effects would undoubtedly have made themselves manifest over a wider area than that occupied by these deposits. The character of the shock, as described by those who experienced it in the vicinity of Clear Lake, agrees, moreover, with that of the shock emanating from the fault at the coast. Becker's geological map of the district shows no faults traversing it.

In general, then, while from the nature of the case it is not possible to deny positively that a local earthquake may have occurred on the morning of April 18, 1906, at the same time as the main shock, no evidence appears to sustain that view. On the other hand the evidence here as elsewhere supports the belief that the apparent intensity is a function of the underlying formations to the extent manifested in this district.

Coming now to Santa Rosa Valley, we encounter an interesting case of high intensity, associated with an alluvial valley-bottom. The valley may be described as an oval-shaped area, extending for 24 miles from Healdsburg to the vicinity of Perm's Grove, with a maximum width of 8 miles on a line lying between Santa Rosa and Sebastopol. The general trend of the central axis of the valley is about N. 30° W. It is thus not far from parallel with the general trend of the fault along the coast. Over a considerable expanse the valley-floor is perfectly even, and appears level to the eye. At its widest portion, however, it has a slope from an elevation of 170 feet above sea-level in the eastern part of the city of Santa Rosa, to about 50 feet above sea-level, a descent of 15 feet to the mile. In this section there are no terraces, but a perfectly even profile. To the north of Santa Rosa, however, the floor of the valley is less even, and it is stepped in a few broad terraces, the lowest of which is the present flood-plain of the Russian River.

The geomorphogeny of the valley is not altogether simple; the primary fact in its development, however, is that it has been carved by stream erosion to its full width out of a great syncline of Merced (late Pliocene) strata.<sup>2</sup> The upturned edges of these Merced strata, planed down to an even but now somewhat dissected surface, constitute the floor of the upper terrace lying to the north of Mark West Creek at an altitude of about 200 feet above the flood plain of the Russian River. On a somewhat lower terrace is the town of Windsor. South of Mark West Creek, the valley is in general deeply alluviated and the wells a little to the east of the city of Santa Rosa (150 feet deep) show that the alluvium is saturated with ground-water to within a short distance of the surface. The distribution of this ground-water thruout the valley is, however, not well known, no systematic investigation ever having been made. On the western side of the valley from Sebastopol

<sup>1</sup> U.S. Geological Survey, Monograph XIIF.

<sup>2</sup> Cf. Osmont, Bull. Ik-pt, Geol., Univ. Cal., vol. 4, No. 3.

northward to Mark West Creek, the drainage is stagnant and gives rise to the Laguna de Santa Rosa. This lagoon is a drowned water course in free connection with the trunk drainage of the Russian River, and is indicative of a deformation of the valley surface whereby the western side has been depressed below the base-level established by the Russian River. From these statements it will be apparent that the whole of the floor of the Santa Rosa Valley is not alluviated, but that portions of it — particularly that portion lying between Mark West Creek and Healdsburg and east of the flood plain of the Russian River — is a terraced platform carved out of the Merced terrane.

Now the notably high apparent intensity of the earthquake shock was confined to the alluviated portion of the valley-floor. The 2 centers of population which suffered most severely were Santa Rosa and Sebastopol. At Windsor, situated on the terrace cut in the Merced rocks, the intensity was distinctly lower. Healdsburg, at the northern extremity of the valley, is also on alluvium and the intensity was here again high, though not quite equal to that at Santa Rosa and Sebastopol. The town of Guerneville, on the old flood plain of the Russian River, below the Santa Rosa Valley, suffered most severely; while the cemetery of the town, but a short distance away, on a rocky terrace 190 feet above the town, was affected in a distinctly less degree, only one monument having been overthrown, and a few moved on their pedestals. The rapid diminution of intensity on passing from the alluvium to the rocky slopes, thus specifically illustrated at Guerneville, is characteristic of the borders of the Santa Rosa Valley. To the east of the city of Santa Rosa, this diminution is so rapid that the gradation of intensity can not be adequately expressed upon the intensity map. Under these circumstances it is difficult to avoid the conclusion that the severity of the earthquake shock on the alluvium of the Santa Rosa Valley is in large measure referable to the character of the ground. Were a local shock a factor in the case, we should expect that the high intensity would not be limited to the alluviated area, but would also be manifested on the surrounding mountain slopes. This expectation not being realized, the hypothesis of an independent local shock stands without support. The general position of the isoseismal curves off the valley-bottoms is not notably affected by the high apparent intensity in the valleys. In arriving at the conclusion that the high apparent intensity in this valley is referable in large measure to the character of the ground, it is not thereby intended to exclude other contributory factors. A theoretical discussion of the effect at the surface of the earth of a concussion at a point within the crust shows that for a certain path of emergence the horizontal jerk of the emerging earth-wave, and, therefore, the destructive effect in general, would be at a maximum. The fact that the earthquake under consideration was due not to a concussion at a point, but to a jar developed by movement on a plane at least 270 miles long, reaching to the surface and of unknown depth, renders the application of this doctrine difficult and of questionable value. Nevertheless, the tendency, which is demonstrable in the ideal case, would also exist in the more complex actuality; and it is by no means impossible that the zone of maximum destruction may fall in a general way within the Santa Rosa Valley, and would thus be a factor conducive to excessive destruction, in addition to the factor inherent in the character of the ground. This suggestion, to have weight, should be corroborated by observations in other portions of the general zone of destructive effects, and it must be confessed that satisfactory corroboration is lacking.

While the geology of the Santa Rosa Valley has not been mapped in detail, owing to the lack of topographic maps, it has been carefully studied, particularly from the structural and stratigraphic point of view, by Mr. Vance Osmond,<sup>1</sup> and no fault traversing the valley was found by him. The underlying structure, so far as has been made out, is as already stated that of a broad, rather simple, synclinal fold. It has also been indicated that the surface of the valley has been subjected to recent deformation, whereby the western side

---

\*.....

» *Hull. Dept. Geol., Univ. Cal., vol. 4, No. 3.*

has been depressed below the local base-level. This may be taken as an indication of the persistence of the compressive forces which originally gave rise to the syncline. If, now the underlying rocks of the valley were in a state of synclinal stress, the relief of that stress afforded by the dislocation along the line of the Rift might give rise to an elastic disturbance of the ground which would be additive to the shock generated at the fault along the Rift.

But none of these suggestions, whether of contributory shock, or an unrevealed fault, or of coincidence of the valley with a vaguely defined zone of maximum horizontal jerk, or of sudden relief from synclinal compression, are sustained by satisfactory evidence. They are possibilities which, with the facts before us, it is possible neither to affirm nor to deny. The reference to them in this place is only excusable on the ground that they are suggestive of lines of inquiry which may perhaps be profitably undertaken at some future time. On the other hand, the influence of the character of the ground upon the apparent intensity is sustained by cumulative evidence.

In Sonoma and Napa Valleys, the disposition of the isoseismals is very evidently determined by the contour of the valleys, the high intensities running far up the valleys within areas of lower intensity on either side. In Sonoma Valley the upper and lower parts are alluviated, while the middle part is not; or, if so, only to a slight extent, and it is being trenched by the stream which flows thru it. The floor of Napa Valley, on the other hand, is alluviated thruout, save for some rocky spurs and isolated rocky hills which occur along portions of the sides of the valley. The intensity diminishes in the upper part of Napa Valley, in the vicinity of Calistoga, where the alluvial deposits thin out, notwithstanding the fact that Calistoga is somewhat nearer the fault along the Rift than is Napa City, at the lower end of the valley, and notwithstanding the fact that Calistoga is approximately on the line of the Mount St. Helena fault described by Osmond. If the relatively high apparent intensity of Napa Valley were in any way referable to a local earthquake on a fault traversing the valley, we should not only expect the effects to be manifested on the rocky slopes of the valley, as well as upon its floor, but would also expect higher intensities on the line of the only well-defined fault known to traverse the valley. Neither of these expectations is realized, and upon the slopes of Mount St. Helena, in the vicinity of the fault which traverses its western front, the intensity was notably low—*not* higher than VI. We are thus again forced to fall back upon the character of the ground as the immediate cause of the high apparent intensity on the alluviated valley-floor, particularly in the lower part of the valley.

Specific and instructive instances of the influence of the character of the ground upon the apparent intensity of the shock are afforded by the cities of Petaluma and San Rafael. Each of these cities is built partly upon rock and partly upon the alluvium of the tidal marshes of the San Francisco Bay. Petaluma is situated at a distance of 14 miles from the fault, and San Rafael at a distance of 9 miles. In both cities the damage to buildings, chimneys, etc., was notably less upon the rock than upon the alluvium, altho the latter can not in either case be supposed to have any great thickness at the base of the hills. (See fig. 64.)

In the city of San Francisco the detailed study of the distribution of intensity, so successfully carried out by Mr. H. O. Wood, affords a conclusive proof of the paramount influence of the character of the ground in determining the high apparent intensities which affected portions of the city. On the made land in the vicinity of the Ferry Building, about 9.5 miles from the fault, as well as on the tidal marsh land, and along Mission Creek and Lagoon, between 7 and 9 miles from the fault, the intensity was X of the Rossi-Forrel scale. But on the rocky top of Telegraph Hill, near the ferries, the intensity was scarcely higher than VII. On the sandstone cliffs at Point Lobos, about 3 miles from the fault, it was about VIII; and on the summits of the chert hills in the cen-

tral part of the city and county of San Francisco, 5 to 6 miles from the fault, it was about VII. On the alluvium of Mission Valley, at distances of from 6 to 9 miles from the fault, the intensity varied from less than VII to between VIII and IX.

Under similar conditions of ground, the shock was greater nearer the fault; but there was much greater contrast between the damage produced by the shock on the summit of Telegraph Hill and that in the vicinity of the Ferry Building, at like distances from the fault, than there was between the damage near the ferries and that in the immediate

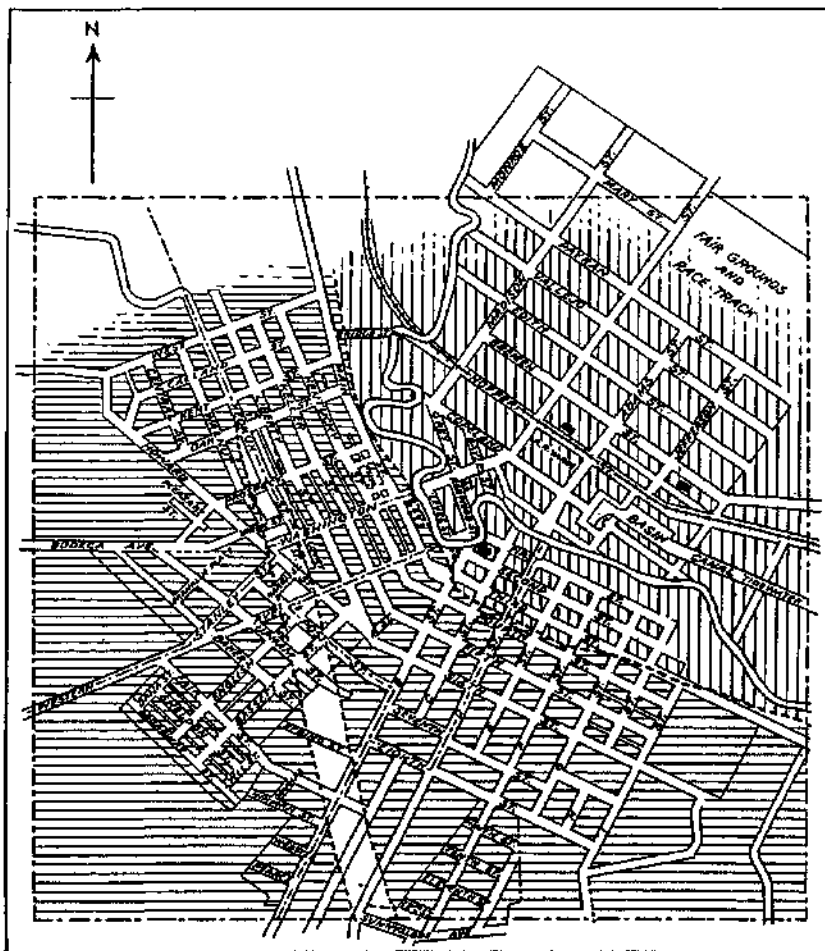

FIG. 04. — Distribution of intensity in Petaluraa. Vertical lines represent area of low-alluvial land, on which nearly all chimneys were damaged. Horizontal lines represent slopes underlain by rock, on which about half the chimneys were damaged. The solid black areas and dots represent exceptionally severe damage. The blank area inclosed by dotted lines represents a belt of practically no damage. By R. S. Hoiway.

vicinity of the fault. Thus, notwithstanding the general tendency of the intensity to diminish with increasing distance from the fault, it seems to be unquestionable that the degree of intensity which prevailed at any locality in the city depended chiefly on whether the underlying formations are firm rock or incoherent material more or less saturated with water. It would even seem possible to discriminate slight differences of apparent intensity on different kinds of firm rock for the same distance from the fault. Thus the chert hills appear to have suffered less disturbance than those where serpentine

outcrops; and the sandstone areas were more disturbed than the serpentine. But these differences are minute.

In the case of the made land and old marsh land of San Francisco, where the apparent intensity reached X, there can be no question as to possible local shocks, since the excessive disturbance was so strictly limited to the area lying outside of the original shore line and marsh border.

In the low ground about San Francisco Bay to the south of the city, we have another instance, on a rather large scale, of high apparent intensity determined by the incoherent water-saturated condition of the underlying formations. San Francisco Bay in general, and the southern portion of it in particular, lies in an alluviated valley which has been deprest so that its central portion is now below sea-level. This submerged valley-floor passes insensibly into the Santa Clara Valley which encloses it on the south and extends southward between the Santa Cruz and Mount Hamilton ranges. Treating San Francisco Bay and Santa Clara Valley as one physiographic feature, it may be stated, without going into the evidence in detail, that depression and alluviation have both been greater in the southern end than in the northern. This southern portion of the valley constitutes a great artesian basin, and many wells have been sunk in it. The deprest trough is not, however, wholly filled by alluvium, since several wells have past through late Quaternary strata containing marine fossil remains. It would appear, from the sections revealed by these wells, that with the progress of subsidence, marine deposition alternated with alluviation. The deposits, whether marine or alluvial, appear to be incoherent or unconsolidated, consisting of clays, sands, and gravels, in layers of irregular thickness and extent. Many wells have past through several hundred feet of such materials without reaching bedrock. One well, on the edge of the marsh near Alvarado, reached rock at a depth of 730 feet. At the sugar-mill at Alvarado, and at the Contra Costa pumping plant, in the same vicinity, there are several wells from 300 to 400 feet deep, passing thru clay, sand, and gravel without reaching bedrock. At Koberts' Landing there are 2 wells, one 574 feet deep and the other 540 feet deep, which past thru alternations of clay, sand, and gravel, but did not reach bedrock. A well 1.5 miles south of Milpitas past thru 11 layers of gravel aggregating 166 feet and 12 layers of clay aggregating 218 feet—total depth 384 feet—but did not reach bedrock. The wells in the vicinity of San Jose range in depth from 35 to 500 feet as a rule. One well on the bank of Guadalupe Creek, however, was sunk to a depth of 1,100 feet, but did not penetrate bedrock. A well at Stanford University is in gravel at 412 feet. On the west side of the Bay there are several hundred wells, most of them less than 100 feet in depth, while the deep ones are usually a little more than 300 feet. Wells are even bored in the bottom of the Bay and an abundant supply of fresh water is obtained from them. These brief statements will be sufficient to afford a general idea of the extent to which the valley has been deprest and filled in with deposits as yet unconsolidated. To the south, the rocky floor of the valley appears at the surface in the vicinity of Coyote, 12 miles south of San Jose. Beyond this, however, the valley again opens out and is deeply alluviated.

On the floor of this valley, from San Bruno Mountain southward, on both sides of the Bay, and southward a few miles beyond San Jose, the intensity was abnormally high. On the rocky slopes between the western edge of the valley-floor and the fault, the intensity had dropt from X at the fault to VIII at the base of the hills. On the valley-bottom it again sharply rose to IX. On this ground were Stanford University, Redwood City, San Mateo, the 44-inch pipe of the Spring Valley Water Company, San Jose, Agnews, Milpitas, and Alvarado. On the eastern side of the Bay the intensity of IX did not persist to the base of the hills, but extended only about halfway from the shore line to the edge of the valley. There was therefore a distinctly diminishing intensity in

approaching the base of the hills on this side of the valley. But at the base of these hills lies one of the dominant faults of the country — the fault upon which movement took place, with rupture of the ground, producing the earthquake of 1868. It would seem that, if local earthquakes were to be invoked to explain the high intensity of the alluviated valley-bottoms, here was a fine opportunity for an illustration of that doctrine. But the seat of the disturbance of 1868 was perfectly passive in 1906. The intensity diminished eastward right up to the fault-trace; and there is no suggestion that the disturbance along the San Andreas Rift affected it in the slightest degree. This being the case, there appears to be no recourse but to ascribe the normal apparent intensity about the southern part of San Francisco Bay to the character of the underlying formations as in other valleys before described.

To the west of the San Andreas fault in San Mateo and Santa Cruz Counties, the apparent intensity diminishes on the firm rocks more rapidly than to the east of the fault, but it rises very notably on the alluvial fan of Pilarcitos Creek at Half Moon Bay, and in the alluviated valleys of San Gregorio and Pescadero Creeks. Going westward down Pilarcitos Canyon, the apparent intensity drops from X at the fault to less than VII within 4 miles of the fault; but along the coastal fringes of alluvium which lie between the hills and the sea, it rises again to VIII at Spanish Town and to IX on the flats below the town. In the valleys of San Gregorio and Pescadero Creeks an apparent intensity of from VII to VIII extends for 4 miles and 3 miles, respectively, into an area of hill lands where the prevailing intensity is from VI to VII. The geology of this region, the Santa Cruz Quadrangle, has been mapped by Prof. J. C. Branner, and no fault is known at Half Moon Bay. Farther south the San Gregorio fault crosses the mouth of San Gregorio Valley and the middle part of Pescadero Valley, with a course parallel to the trend of the coast or transverse to the axes of the valleys. But the high apparent intensity in the bottoms of these valleys can not be referred to a local earthquake due to movement on this fault, since on either side of both valleys, in the immediate vicinity of the fault, it drops to below VII; while a few miles farther south on the same fault the apparent intensity drops to VI.

At Santa Cruz a portion of the city is built partly on a series of broad wave-cut terraces in the bituminous shale of the Monterey series and partly on the alluviated bottomlands of San Lorenzo River. The contrast in apparent intensity in these two portions of the city is marked. In that portion which is situated upon the terraces the apparent intensity ranges from VII to VIII, while on the bottomlands of the river it rises to from VIII to IX. It thus appears again, from a consideration of these four cases on the coast extending from Half Moon Bay to Santa Cruz, that the character of the material in the alluviated valley-bottoms has exercised a dominant influence in determining the apparent intensity of the earthquake shock, and that there is nothing in the facts to suggest that any other factor has played an important rôle.

The finest illustration of the influence exercised by alluvium in the production of high apparent intensity is that afforded by the valley of the Salinas River and its extension to the valley of the lower portion of the Pajaro River. The Salinas Valley is one of the notable physiographic features of the Coast Ranges. It lies between the Santa Lucia and Gavilan Ranges. It is deeply alluviated and strikingly terraced, particularly in its lower part. The course of the valley was probably determined originally by the fault along the eastern base of the Santa Lucia Range. The river discharges into the Bay of Monterey about its middle part, a few miles south of the mouth of the Pajaro River. On the flood-plain tracts of both rivers, and along the beach of the Bay of Monterey, the intensity was IX. This extended up the river for several miles above the town of Salinas. There were extensive fissures in the alluvium as far as Gonzales, with slumping of the ground toward the river trench. Damage of structures, indicating an intensity

of VIII, extended up the valley as far as Chualar; and the limit of intensity, VII, was reached only at King City, 45 miles above Salinas; VI in the vicinity of San Ardo, 65 miles; and V at Pass Robles, 99 miles above the same point. The isoseismals drawn thru these points are almost parallel to the river, the intensity to the east and west diminishing rapidly. The town of Salinas is about 13 miles distant from San Juan, in a direction normal to the fault-trace. On the northern end of the Gavilan Range, which intervenes between the two valleys, the apparent intensity dropt to V and then rose rapidly to IX in the Salinas Valley. The limitation of the high apparent intensity to the valley-floor, the practically symmetrical parallelism of the isoseismals to the median line of the valley, and the diminution of the intensity with the thinning of the alluvium and the constriction of the valley upstream, all indicate dependence of the character of the shock upon the constitution of the underlying formations, and suggest no other factor.

Still farther south in San Luis Obispo and Santa Barbara Counties, far beyond the isoseismal IV, an apparent intensity of IV is indicated by the effects observed in the valley-lands at San Luis Obispo, Edna, Arroyo Grande, Pismo, Santa Maria, Casmalia, and Lompoc. In the flat alluviated valley-bottom in which the town of Hollister is situated, about 8 miles east of the southern end of the fault at San Juan, the apparent intensity rose to IX, but diminished very rapidly on the hill lands immediately to the east of the valley to VI, which appears to have been the normal intensity for the mountainous tract between Hollister and the San Joaquin Valley.

Farther southeast there was a similar but less marked rise in the apparent intensity at Lonoak, Priest Valley, and Hernandez, all of these being on alluviated bottoms.

In the alluviated valleys to the east of the Berkeley Hills, the apparent intensity was abnormally high and the area occupied by these valleys constitutes an isolated area in which the intensity ranges from VII to VIII in the midst of a belt in which the range is from VI to VII. At Pleasanton the intensity was somewhat higher than at Sunol, altho the latter is nearer the fault of April 18, 1906, and is situated, moreover, on the line of an old fault which traverses the west side of Livermore Valley and extends up Calaveras Valley into the Mount Hamilton Range. At Livermore, in the more open part of the valley, where the alluvium is deeper, tho 8.5 miles farther from the seat of disturbance, the intensity was about the same as at Sunol. At Martinez, on an alluviated embayment of Suisun Bay, the damage clue to the shock was much greater than in neighboring towns situated on rock, even when the latter were nearer the fault. Beyond Martinez to the eastward there is a very marked bulge to the east of Suisun Bay, in the isoseismal VII, which can be attributed only to the low and marshy character of the ground. The apparent intensity at Antioch was a degree higher in the scale than that at Mount Hamilton, altho it is double the distance from the fault of April 18; and altho there are several old faults in the vicinity of Mount Hamilton and none are known near Antioch.

The influence of the valley-lands upon the apparent intensity is well shown on a large scale in the disposition of the isoseismal curves about the Sacramento Valley. In the mountains to the west of the Sacramento Valley the apparent intensity ranges in general from VI to V; but on the floor of the valley eastward to beyond the Sacramento River, it is very uniformly about VI or VI+.

The most interesting case of high apparent intensity in a valley-bottom remote from the San Andreas fault is that of the San Joaquin Valley. This case merits especial consideration, since of all the valleys here considered it is the one which is most suggestive of the occurrence of a local earthquake, distant from, tho connected with, the main movement on the San Andreas fault. While the suggestion is strong, however, the evidence is not conclusive of the occurrence in this region of a quasi-independent

earthquake; and all that can be done is to indicate the evidence which points that way, and cite certain facts which detract from the force of that evidence and tend to correlate the locally high intensity in the San Joaquin Valley with similar high apparent intensities in other valleys thus far discussed.

The apparent intensity on the floor of the Sacramento Valley, as has been stated, ranges about VI+ of the scale. This is somewhat higher than at several points in the adjacent Coast Ranges to the west, and the difference is ascribable to the alleviated character of the valley-floor and the water-saturated condition of the alluvium. As we follow the Sacramento Valley southward into the San Joaquin Valley, it converges upon the San Andreas Rift, and we should naturally expect an increase in the intensity by reason of the diminution of the distance from the seat of disturbance. This expectation is in a measure realized by an eastward bulge in the isoseismal VII opposite Suisun Bay, and by the somewhat higher intensity at Tracy and Westley than at Sacramento and Stockton.

Southward from Westley, however, the apparent intensity increases at a rate which can not be referred to the slight approximation of the region to the seat of the main disturbance. At Crow's Landing the apparent intensity is VII; at Newman it is VIII; at Volta it is VIII+; and at Los Banos it is IX. These points lie on the west side of the valley between the San Joaquin River and the flanks of the Coast Ranges. South of Los Banos, on the valley floor, settlements are very few, and information as to the apparent intensity is unfortunately lacking over an extensive territory. At Coalinga, however, the apparent intensity is VII, indicating that the abnormally high figures prevail over the western side of the valley from Crow's Landing to southward of Coalinga, a distance in a north and south direction of not less than 100 miles. That the high apparent intensity was not wholly confined to the valley-floor, but also extended into the flanks of the Coast Ranges, is shown by the remarkable series of landslides which were started by the earthquake for a distance of about 23 miles northwestward from the vicinity of Cantua, reported by Mr. S. C. Lillis, and described by Prof. G. D. Louderback in another part of this report.

Now Los Banos, where the apparent intensity was highest, is distant 40 miles from the nearest point on the San Andreas fault at San Juan, its southern end. It is nearly 34 miles in an air-line from Hollister, the nearest point to the westward having a similarly high apparent intensity. In the Coast Ranges between Hollister and Los Banos, the intensity was as low as V.

These facts are suggestive, as already stated, of a local disturbance at or about the same time as the main movement along the San Andreas fault.

Certain circumstances detract, however, from the force of this suggestion, and indicate another possible explanation which, it must be confessed, is not very conclusive in view of the remoteness of Los Banos from the seat of disturbance. The portion of the San Joaquin Valley in which Los Banos lies is undoubtedly an underground water reservoir. It lies at the base of the alluvial fans of the Coast Ranges where the streams sink, and the waters of the San Joaquin River maintain the water-table at no great distance below the surface. As shown by the experiments of Prof. F. J. Rogers, described in another part of this report, water plays an important part under certain conditions in increasing the amplitude of the earth vibrations and, therefore, their destructive effect. In this respect the region about Los Banos would be particularly favorably conditioned for the development of high apparent intensities, as inferred from destructive effects. His general conditions are quite analogous to those in the Salinas Valley, in the bottom-lands of the Pajaro River and the Russian River, and in the region about the south end of San Francisco Bay. The chief difference is in the greater remoteness of the Los Banos region from the seat of disturbance, if only one such seat be assumed.



Another circumstance which weakens the suggestion of a local earthquake is the failure of the isoseismals below VII to carry out the suggestion by bulging into the Coast Ranges on the west or the flanks of the Sierra Nevada on the east. In the latitude of Los Banos, the high apparent intensity was confined to the valley-floor, altho farther south, near Cantua, this can not be affirmed. In view of the experiments of Professor Rogers, it seems probable that in the near future, by an active prosecution of such experiments coupled with close field observation, we shall arrive at an arithmetical expression for the coefficient which will enable us to reduce the apparent intensity of water-saturated alluvium to the true intensity due to vibration in homogeneous elastic rock. When that coefficient becomes available, it will perhaps be possible to determine whether or not the destructive effects exemplified in the San Joaquin Valley at Los Banos are referable to the conditions of the ground or to a local seismic disturbance. Until then the question must remain an open one. Analogy with other valley lands nearer the fault, where high apparent intensities are referable, both on the field evidence and in the light of Professor Rogers' experiments, to local conditions, militates against the hypothesis of a quasi-independent earthquake. The remoteness of the region from the known fault and the high intensities on the flanks of the Coast Ranges indicated by the new landslides at Cantua, favor that hypothesis; but no positive conclusion can be reached at present.

#### RELATION OF APPARENT INTENSITY TO KNOWN FAULTS.

Altho the geology of California has been studied in detail at but few localities outside of the gold belt of the Sierra Nevada, yet the general reconnaissance work that has been done by various geologists has brought to light many of the important faults in the state. Such as are known are indicated on map No. 1, without any attempt to discriminate between the varying degrees of certainty with which their existence has been determined. The map serves the double purpose of bringing together for the first time our knowledge of the distribution of faults thruout the state, and of illuminating a brief discussion of the relation of apparent intensity to fault-lines. On 4 of these faults there have occurred 5 severely destructive earthquakes within the last 50 years. It thus behooves students of Californian seismology to become familiar with these structural features of the state. A recent account of the Calabrian earthquake of September 8, 1905, dealing particularly with the distribution of intensity,<sup>1</sup> and the relation of that distribution to fault-lines known or inferred, gives an especial interest to the consideration of the faults of the Californian region at this time. In the preceding section of this report, it has been shown very definitely that abnormally high apparent intensities were developed on the valley-bottoms, and the cause of this has been referred in a general way to the incoherent and water-saturated condition of the materials underlying these valley-bottoms. In Calabria, in the account referred to, Professor Hobbs correlates the zones of exceptionally high intensity with lines of ancient faults, which in some portions of the region are known on geological evidence to exist, and in others are supposed to exist because of the high intensities manifested. He does not recognize the character of the underlying formations as an important factor in producing different degrees of intensity, as inferred from destructive effects at the surface. In this respect his conclusions do not harmonize with those arrived at in the study of the California earthquake of April 18, 1906. It thus becomes a matter of interest to ascertain what, if any, influence was exercised by the known faults of California, other than that which was the seat of disturbance, upon the distribution of apparent intensity, independently

---

<sup>1</sup> W. H. Hobbs, *The Geotectonic and CJeodynamic Aspects of Calabria and Northern Sicily*. Leipzig, 1907.

of that which was clearly due to the character of the geological formations. This question has been touched upon incidentally in the discussion of the relation of the valleys to distribution of apparent intensity, but it will be of advantage to review the facts here more systematically, tho quite briefly.

In southern Oregon and in northeastern California, in Modoc, Shasta, Lassen, and Plumas Counties, the shock was so uniformly feeble that there is no suggestion of locally high intensity due to any cause. The same general statement is true of northeastern California, in Del Norte, Siskiyou, Humboldt, and Trinity Counties; but in this region some of the faults, particularly that of Redwood Mountain, were not farther from the seat of disturbance than certain localities farther south, where abnormally high apparent intensity was developed on valley-bottoms. If the Redwood Mountain fault had been a locus of movement, there can be little doubt, altho the settlements in that region are few and scattered, that we should have heard of the severity of the shock. No evidence, however, has come to hand indicative of any exceptional severity on or near the line of that fault.

Along the eastern front of the Sierra Nevada, from Honey Lake and the Taylorsville district to Tejon Pass, altho there are many extensive faults, and altho on one of these there occurred a movement which caused the Inyo earthquake of 1872, yet there is no suggestion of any local movement on any of these on the morning of April 18, 1903. The intensity of the shock along this general fault-zone was about IV of the scale; but the movement was a slow, gentle swing characteristic of a heavy distant shock.

Similarly, the numerous faults which traverse California south of Tehachapi may be left out of consideration, no shock at all having been felt over the greater part of the region, and but feebly in those parts where it was felt.

There thus remain of the faults in California practically only those that fall within the zone of destruction, to merit serious consideration. The most northerly of these is the Mount St. Helena fault described by Osmont.<sup>1</sup> This fault has a northwest-southeast strike, and a throw of not less than 2,000 feet. It forms a well-marked and little-degraded scarp on the southwest side of the mountain and the date of its principal movement is within the Quaternary period. The projection of this fault to the northwest is not known; to the southeast it undoubtedly passes beneath the floor of Napa Valley, in the vicinity of Calistoga. Neither on the slopes of the mountain nor at Calistoga was there any evidence of abnormally high intensity, and the necessary inference is, therefore, that there was no movement on the fault at the time of the earthquake.

The southwest front of the Berkeley Hills, and the extension of the same geomorphic feature farther south, forming the southwest front of the higher Mount Hamilton Range, is with little question a fault-scarp, or series of scarps, of Quaternary date, now more or less dissected and degraded. The northern extension of the fault-zone beyond San Pablo Bay is not known. It probably contributed to the definition of the western side of the ridge between Sonoma and Petaluma, but apparently did not traverse the middle part of Santa Rosa Valley, since the study of that region by Osmont failed to reveal it.

This fault-zone is of peculiar interest from the point of view of the present discussion, since it appears to have been the seat of disturbance of the earthquake of 1868. At that time the fault-trace was marked by a crack at the surface, which was traceable for 20 miles or more along the base of the scarp slope, altho the amount of the movement was probably quite small. The trace of the fault is approximately parallel to the San Andreas Rift, and is 18 miles distant from it. As has already been suggested, this fault would seem *a priori* more susceptible to the influences which would make for renewed movement than most other faults of the region. But there is no evidence that any movement occurred upon it. The intensity showed no abnormal increase along

---

<sup>1</sup> *Lot. cit.*

the old fault-trace; and buildings at Berkeley, founded on rock, practically on the line of the fault, suffered little or no damage.

The fault which is so well exposed in the sea-cliff south of Fort Point traverses the city of San Francisco in a southeasterly direction for an unknown distance. Along the line of its probable course, Mr. Wood has noted evidence of an increase of intensity. The fault in its projection seaward probably intersects the San Andreas fault beneath the Gulf of the Farallones. It is therefore possible that there was some slight distribution of the movement along this intersecting fault.

The San Bruno fault-scarp, on the peninsula of San Francisco, south of the city, is well illustrated in Plate 15, and its structural relations are described in a paper by Andrew C. Lawson on the Geology of the San Francisco Peninsula.<sup>1</sup>

The base of the scarp is from 2.5 to 3 miles distant from the San Andreas Rift, and is nearly parallel to it. The fault is in two parts: a main fault with a throw of not less than 7,000 feet, which drops the Merced (Pliocene) strata against the older Franciscan rocks, and an auxiliary fault which drops a wedge of Franciscan strata between the main fault and the mass of San Bruno Mountain. The town of South San Francisco is on the lower slopes of a rocky spur of San Bruno Mountain, between the two faults, i.e., it is on the dropt wedge of Franciscan rocks. In the water-saturated alluvium and sands of Merced Valley, the apparent intensity was high, ranging up to IX of the scale; but in South San Francisco, on rock foundation, it was notably lower, as appears from Mr. Crandal's report. The situation of south San Francisco, between the two faults, is such that had a movement occurred on either, the damage to structures would have been accentuated. But the fact is that the damage was not so accentuated, and there is thus no warrant for supposing that any local fault movement occurred.

One circumstance which, upon first thought, seems to contravene this conclusion, was the sudden outgush of water at one point at the base of the San Bruno scarp. This remarkable occurrence is described in another place, but may be mentioned here, for the purpose of bringing together the facts bearing on the question. The water issued, as near as can be determined, at a point on the slope immediately above the fault-trace of the auxiliary fault, in the underlying hard rocks, which are there mantled with an unknown thickness of sand, possibly 50 feet or more. The outgush of water is indicative of sudden compression of incoherent water-saturated sand, and does not necessarily imply a movement on the deeper fault. Along the line of the fault there are longitudinal depressions, and it is suggested that one of these was filled with sand, under conditions which did not permit of rapid drainage; so that the sand was saturated with water, which was expelled as the compressive wave traversed the locality.

In the region to the southwest of the San Andreas Rift in San Mateo and Santa Cruz Counties there are several faults, most of which are represented on maps Nos. 21 and 22. No evidence of movement has been detected on any of them, altho the territory has been examined quite closely; nor does their presence appear in any way to have affected the disposition of the isoseismal curves. They nearly all traverse a country occupied by rocky mountainous slopes, and have considerable variation in orientation, altho the prevailing strike is northwesterly and southeasterly. One fault, however, viz., the San Gregorio fault, crosses 2 valleys — San Gregorio Valley and Pescadero Valley — in which the intensity of the shock was abnormally high. The independence of this high apparent intensity to the fault has been pointed out in another place.

To the north of Black Mountain, on the northeast side of the San Andreas Rift, a branch fault leaves the Rift line a little south of Portola, at an angle of about 25°, and is traceable for about 8 miles on the lower northeastern flank of Black Mountain. Between this Black Mountain fault and San Andreas Rift there is enclosed a wedge of

---

<sup>1</sup>U. S. Geological Survey, 15th Ann. Report.

ground in which the shock was of exceptional severity. It was traversed by numerous cracks, and there are other manifestations of acute disturbance of the ground, as set forth in the more detailed section of the report. In this case it is quite possible and even probable that the movement on the main fault in the line of the Rift was distributed to some slight extent along the branch fault. It is to be noted, in this connection, that to the south of Black Mountain there is a slight curvature in the course of the main fault to the eastward. This curvature would present an exceptional obstacle to the movement of the two crustal blocks, the one on the other, greatly increase friction, and so locally intensify the shock. It may thus be that the exceptional intensity in the Black Mountain mass, and the consequent bulging of the isoseismals on either side of the fault in this vicinity, is referable to this irregularity in the plane of the fault; and that the branch fault at Portola may be a means of relief from the excessive pressure locally induced by the irregularity. On the southwest side of the San Andreas Rift, and on the other side of the bulge in the fault-trace, is the Castle Rock fault, the strike of which branches from the main fault on the Rift at an angle of about  $20^\circ$ . Altho this fault has not been actually traced into the line of the Rift, there can be little doubt that it is a branch from that fault-zone and it probably bears the same structural relation to it that the Black Mountain fault does<sup>^</sup> *i.e.*, it serves as a means of relief for the exceptional local pressure due to the nearby irregularity in the main fault. There is, however, no observational evidence of any movement having occurred on the Castle Rock fault on April 18, altho it lies within the region of bulging isoseismals.

In the Mount Hamilton Range, between Niles Canyon and Mount Hamilton, there are many faults; but none of them, so far as the information available will warrant a conclusion, appears to have affected in any way the distribution of intensity. Two of these, the Mission Peak fault, which is probably a branch from that on which cracks opened in 1868 near Haywards, and Mission Creek fault, pass close to the town of Niles. But the apparent intensity at Niles was less than on the flat alluvial tract to the west, and not greater than in the valley-land about Pleasanton and Livermore to the east; and this circumstance amounts to a proof that no movement occurred on either of these faults. A similar conclusion may be drawn with reference to the Sunol fault, from the fact that the apparent intensity at Sunol was somewhat less than at Pleasanton, altho the former is nearer the Sunol fault than is the latter. In the country between the Haywards fault and the Sunol fault there are several minor faults, but there is no indication in the distribution of intensity of movement having occurred on any of them. Similar statements are true of the fault zone extending from the vicinity of Benicia northward on the west side of the Sacramento Valley.

In the canyon of Pajaro River, below Chittenden, there is an east-west fault whereby the Tertiary rocks on the north side have been dropt against the granitic rocks of the Gavilan Range on the south. This fault crosses the San Andreas Rift, and its known extent on either side of the Rift is within the zone of high intensity referable to the movement of April 18. There are here no especial features in the distribution of apparent intensity which suggest any movement on this fault. It is possible, however, that a slight movement took place on this fault, since the steel bridge over the Pajaro River, which is about on the intersection of the two faults, was distended 3.5 feet between its end piers, as shown in plate 65B, in a way that can not be altogether satisfactorily explained by the movement on the fault along the Rift. The direction of the chief displacement of the piers was about midway between the strikes of the two faults.

In the Santa Lucia Range to the southwest of the Salinas Valley, there are several faults. The principal one runs along the northeast flank of the range on the edge of the Salinas Valley. The reasons for ascribing the high apparent intensity on the floor of the Salinas Valley to the character of the underlying fontir\* ions, rather than to any

disturbance on this fault, have already been stated. Farther south, a fault runs parallel with the Salinas River in that portion of its course between Templeton and Dove; but here the apparent intensity was lower than in the valley lands both to the north and to the south.

To the southwest of this is another parallel, but a longer fault, along the southwest side of the San Rafael Mountains. In the valley lands to the southwest of this, about San Luis Obispo, Edna, Arroyo Grande, and Santa Maria, the intensity rose from III to IV; but in view of the accumulation of evidence set forth in the preceding pages as to the influence exercised by alluviated bottoms upon the apparent intensity, this rise is more probably referred to the character of the ground than to proximity to this fault-line. South of Santa Maria is a region of frequent seismic disturbance, but no sharp shock of a local earthquake was felt there on April 18.

It thus appears that in the territory extending from Humboldt County to Santa Barbara County, while there are about 40 faults known to geologists who have studied the region, there is no evidence of movement on any of them except in 3 cases. One of these is a branch from the fault-zone of the San Andreas Rift — the Black Mountain fault; another is a transverse fault intersecting the Rift in Pajaro Canyon; and the third is the fault which traverses the city of San Francisco and probably intersects the San Andreas fault beneath the Gulf of the Farallones. In these cases it is possible, in the light of the evidence, that some portion of the movement on the main fault was distributed along intersecting faults.

## DIRECTIONS OF VIBBATOBY MOVEMENT.

---

### GENERAL NOTE.

The data for the discussion of the directions of propagation and vibration of the earth-waves is for the most part unsatisfactory and leads only to a conviction of the complexity of the general problem of earth movement. Apart from the intrinsic complexity of the subject, there were two conditions which were adverse to the securing of exact and significant information. The first of these was the lack of provision for obtaining instrumental records of earthquake shocks thruout California. There were very few seismographs installed in the state and such as were in existence proved in large measure inadequate for the purpose for which they were intended. The second adverse condition was the hour at which the earthquake began. At its beginning most people were asleep, and the confusion incident to so rude an awakening was not conducive to sharp observation. The chief trouble, however, inheres in the intricate and confused nature of the earth movement itself. A brief statement of the different kinds of movement involved in the commotion of the earth may be of service in the formulation of clear ideas of the nature of the shock in general and of the question of direction in particular.

Usually the principal movement of the ground in an earthquake is vibratory. In the California earthquake there was, however, a mass movement in opposite directions on the two sides of the San Andreas fault. This mass movement was, as has been shown by the work of the Coast and Geodetic Survey, distributed over a wide zone on either side of the fault and diminished more or less regularly with distance from it. The movement was not vibratory except to a very limited extent; but it gave rise to the displacement of objects on the surface quite similar to that caused by the vibratory movement.

Thus, in attempting to deduce the directions of propagation and vibration of the earth-waves from the phenomena of displaced objects or persons, it is necessary to discriminate between the effects due to the mass movement and the true vibration of the ground. But this discrimination is only possible to a very limited extent, partly because the borders of the zone within which the mass movement caused the displacement of objects and persons are unknown, and partly because the two kinds of movement overlapt, conspiring to produce a single effect.

When we come to consider the earth-waves generated by the movement on the fault, probably as an effect of friction, it must be at once apparent that these waves emanated from innumerable points on a plane, one dimension of which is about 270 miles and the other probably 20 miles or more. On this plane, if we judge from the course of the fault-trace, there were at certain places inequalities which offered exceptional resistance to movement, and at these the jar was exceptionally heavy and dominated the vibrations emanating from portions of freer movement. From all parts of the fault-plane, therefore, waves of various amplitudes were propagated in all directions, and their paths intersected. The consequent interference would in part make for neutralization and in part for intensification of the vibratory movement. It is thus evident that the effects produced by the emergence of these waves at the surface, or by the propagation of those emanating from the more superficial portions of the fault along the surface, could be systematically disposed only if the following conditions obtained:

1. That the fault-plane were uniformly even or systematically uneven.
2. That the rock affected both by the rupture and by the vibrations were homogeneous throughout.
3. And that the stress which gave rise to the rupture were uniform for the entire extent of the fault.

It is fairly certain that none of these conditions actually did obtain; and we might, therefore, predict that the disposition of the effects of the shock, and particularly of the heavier portions of the shock, from which directions might be inferred, would be irregular, tho' the distribution of the intensity in the aggregate might be fairly symmetrical.

This conclusion has been reached on the tacit assumption that there is but one kind of earth-wave or vibratory movement. But it is highly probable on theoretical grounds, and the theory is supported by experiment, that the vibration of the earth generated at the fault resolves itself into two quite distinct waves having quite different rates of propagation and direction of vibration. One of these is the longitudinal wave, so called because the vibrations are parallel to the direction of propagation, and the other is the transverse wave in which the vibrations are normal to the direction of propagation. The rate of propagation of the longitudinal waves in highly elastic rocks is nearly double that of the transverse waves. It will thus be evident that at any locality within the zone of disturbance an object may be shaken or displaced by the emergence of the longitudinal wave at that point, and that the movement due to the emergence of the transverse wave may be superimposed upon this either before or after it has come to rest. The resultant effect will be accordingly difficult to interpret as to the direction of the vibration for either wave. When, however, the locality in question is sufficiently far removed from the fault, the interval between the emergence of the two waves may be sufficiently long to permit of the effect of the first being noted before that of the second is superimposed.

In the case of the California earthquake, the movement of the ground was complicated by the fact that both longitudinal and transverse waves were propagated in directions nearly parallel to the surface from the superficial portion of the fault, and these for many miles out from the fault might be expected to give rise to movements discordant with those due to the arrival of similar waves from the deeper portions of the fault. It would thus seem, from the considerations thus far presented, that regularity in the disposition of the effects of the shock upon which a judgment as to the direction of the vibration might be based, was about the last thing to be expected. In other words, it would seem, on *a priori* grounds, to be a hopeless task to plot upon a map of California the direction of propagation and vibration of the earth-waves. The hopelessness of the task is intensified when certain other considerations are taken into account. For example, there were secondary short surface-waves of low speed and high amplitude observed in many parts of California, which are quite different from the high-velocity waves thus far discussed. These undoubtedly had an important effect in the displacement of objects and persons, and so influenced judgments as to the direction of movement. Similarly on the alluvial bottoms of the rivers the ground lurched consistently toward the stream trench, whatever the orientation of the latter might be; and the phenomena arising from such movement gave rise to judgments as to the direction of the earth-waves which were of course erroneous.

Added to all this was the general fact that those who contributed reports from various parts of the state to the general account of the earthquake in many cases based their judgment as to the direction of the shock upon the displacement of portions of structures, such as chimneys, or of objects within buildings. This kind of evidence was in most *instances* untrustworthy, and could lead to reliable conclusions only when treated critically and statistically so as to obtain a general result. Even the displacement of buildings

themselves was no criterion of the direction of vibration of the ground except when these rested upon uniform foundations. Buildings upon poorly braced underpinning, such as are common in California, collapsed in consequence of the swaying; but the direction of the horizontal element in the collapse was more often determined by the nature of the structure than by the dominant movement of the ground. Even in cemeteries the direction of overthrow of simple shafts, circular or square in cross-section, failed to indicate the direction of the dominant movement, since within a small radius they fell to all points of the compass. The indication of the cemeteries was that the movement of the ground was very complex; the shafts were started swaying upon their pedestals, and the direction of their fall was for the most part accidental, as the rocking increased in violence due to the accumulating impulse. Treated statistically, however, the larger cemeteries afforded some indication as to the direction of the dominant movement of the ground.

In view of what has been said, it will not be surprising that the effort to interpret the reports from various parts of the state regarding the direction of movement of the ground has been unsuccessful. The reports were in general contradictory for the same locality whenever there were two or more independent observers. It was evident that most of the reports were based on evidence of the movement of the ground which had no significance in isolated instances, and a general critical review of the evidence was attempted only by a few observers. It was also evident that in many cases the effects of one movement had impressed one observer, while the effects of a different movement had attracted the attention of another. In these cases the contradiction was more apparent than real, but there was general doubt as to the correctness of both. Even when the reports were perfectly satisfactory records of facts, the latter in many cases permitted of no safe inference as to direction of movement except that there were several movements in several directions, and that the sequence of these could not be determined.

The following report from E. G. Still of Livermore is a good example of an excellent account of the important facts bearing on the question of directions:

The Railway Company's big 20,000-gallon water-tank fell to the north-northeast. Tombstones in one graveyard fell in many directions. Lamps swung in an oval, extending about east and west. The motion seemed to shake my bed north and south at first, then in a circular motion, then sideways and in every direction. Water spilt from full tanks, mostly on east and west sides.

There is a suggestion here of two dominant movements — a northerly and southerly, and an easterly and westerly, the former being the earlier. But Mr. Crandall, for the same territory, reports that the general direction of motion, based on the observed spilling of liquids and swaying of suspended objects, was northwest and southeast. In most cases the reports consist of a statement of opinion as to the direction of movement, without the facts upon which the opinion is based.



**EFFECTS OF THE EARTHQUAKE ON HOUSES IN SAN MATEO AND BURLINGAME.**

BY ROBERT ANDERSON.

Immediately following the earthquake of April 18, 1906, a detailed study was made by the writer\* of over 1,000 houses in San Mateo County. This work was carried on under the direction of Dr. J. C. Branner, of Stanford University. The houses examined included all those in the town of San Mateo and on the hills west of it in Burlingame and San Mateo Heights, as well as many in Homestead, Belmont, San Carlos, and Redwood City. Examination was made of all details that could possibly give a clue to the character of the earthquake shock, and its effects upon movable things.

San Mateo is a mile west of San Francisco Bay, and about 3 miles northeast of the San Andreas fault along which the earthquake had its origin. All the houses included in this investigation lie between 1 mile and 4 miles in a northeast direction away from the nearest points along the fault. A range of hills from 500 to 700 feet high lies between the fault and the valley bordering the bay where San Mateo and Redwood City are situated. The houses examined at Burlingame and San Mateo Heights stand on the northeast flank of this range of foot-hills. It was hoped that the directions of the streets of San Mateo, parallel and at right angles to the fault, would throw some light upon the relations of location to the center of disturbance.

## CRITERIA.

The following classes of evidence were examined, with especial regard to the direction and relative force of the shock:

1. The wreckage of brick, stone, and wooden buildings, the parting of walls, and displacement of parts.
2. The cracking of foundations and the movement of houses on them.
3. The cracking, crumbling, shifting, falling, jumping, and twisting of brick chimneys above and below roofs, as well as of cement, terra-cotta, and other chimneys.
4. The cracking and falling of plaster and coatings of cement on the interior and exterior of buildings.
5. The sliding, falling, and jumping of dishes, lamps, bric-à-brac, pictures, books, potted plants, and all such loose articles.
6. The sliding, tipping, jumping, and turning of furniture, such as bureaus, tables, bookcases, beds, pianos, stoves, safes, machinery, and all other large movable articles.
7. The falling, sliding, twisting, and jumping of tanks, towers, porches, pillars, underpinnings, gate-posts, mantelpieces, derricks, etc.
8. The breaking and offsetting of pipes, bending of bolts, shifting of stove-pipes, bulging of windows with lead seams, and the raising and lowering of sliding windows.
9. The shifting of loose piles of lumber, stove, and cord wood, and various materials, and the sliding of articles on rough and smooth surfaces.
10. The swinging of hanging articles, pictures, lamps, pendulums, etc.
11. The breaking of wire connections, such as telephone, telegraph, and light wires.
12. The remaining in position of articles at liberty to fall in certain limited directions.
13. The parting of ground at base of telegraph poles and cracking of ground elsewhere.
14. The spilling and splashing of liquids.
15. The feelings, experiences, and testimony of people.

This paper gives only the general results of all the data, the more important facts alone being tabulated.

---

<sup>1</sup> Valuable aid was received from P. C. Edwards, A. L. Motz, and A. F. Taggart, students of Stanford University.

DAMAGES.

*The effects upon brick and stone buildings.* — The region covered has only about 25 buildings of brick and stone. In most cases, the damage done to these structures was far more severe than to those of wood. "Usually a considerable part of some of the walls crumbled away, while the rest were left standing with large and small cracks in them. The tops of walls below the roofs usually suffered most, while lines of weakness in walls, caused by the presence of windows, arches, and other apertures, gave way to cracking more readily than other parts. A few brick buildings were totally demolished, as in the case of the long, brick, railroad warehouse at San Mateo. (See plate 98A.) The whole center of the picture to the right and left of the tower was occupied by the building, of which only the foundation remains.

Some brick buildings, stoutly constructed or wedged in on business blocks among structures that acted as common supports, withstood the earthquake well, altho some portion was almost invariably damaged. The triangular gable ends of brick buildings rarely remained in place. The cracking in brick structures seldom past thru the brick themselves, but usually took place along lines of cementing. The very few stone buildings in the vicinity of San Mateo were almost shaken to pieces.

*Wooden buildings.* — In general, wooden structures suffered much less severely than those of brick or stone, tho the shock was felt just as heavily in them and the damage to loose articles was just as great. The buildings least damaged were small wooden houses, which were practically proof against the earthquake.

*Foundations.* — The effect of the earthquake on foundations was of great importance, for the foundations were responsible for much of the damage to upper parts of buildings. With reference to this point, the buildings have been divided into 3 groups — those having foundations of wood, of concrete, or of brick. Wooden foundations are of various kinds, and the group includes all houses resting directly on the ground, or on wooden sills or wooden underpinning, even if the latter are supported on brick piers; it also includes all other buildings not having foundations of hard materials, such as concrete, brick, or stone.

The foundations were examined for evidences of movements in various directions, and for the purpose of learning the relative amounts of cracking to which each was subjected. The accompanying table gives the results:

*Number of houses examined, with, number of houses moved, and number of foundations cracked.*

Character of foundation	SAN MATEO.			REDWOOD.			BISL MONT, HOMESTEAD, AND SANCAKI'OS.			BUHXINGAMK AND SAN MATEO HILLS.			TOTAL.				
	Houses examined.	Houses moved.	Foundations cracked.	Houses examined.	Houses moved.	Foundations cracked.	Houses examined.	Houses moved.	Foundations cracked.	Houses examined.	Houses moved.	Foundations cracked.	Houses examined.	Houses moved.	Foundations cracked.		
Wood . .	266	47	....	63	23	....	50	2	....	8	1	....	387	73	17	....	....
Concrete .	176	61	43	7	7	....	1	....	1	41	7	....	225	59	26	51	23
Brick . .	160	61	63	8	3	1	16	....	4	46	4	26	230	58	26	94	41
Total .	602	149	106	78	33	1	67	2	5	95	6	33	842	190	23	145	

The total number of houses falling into these groups is 842. Of these 23 per cent moved on their foundations. In most cases the movement was not so great as to necessitate the returning of the house to its original position, but this had often to be done, since many houses were rendered unstable. The distance moved varied from less than 0.25 inch to several inches, and in cases of special severity houses were thrown a foot or more off their underpinnings or foundations. Those on wooden foundations moved the least — 17 per cent in a total of 387 such houses. There were 225 houses on concrete

foundations and 230 on foundations of brick, and in each case 26 per cent moved. Out of the total of 455 concrete and brick foundations, 32 per cent were cracked, as follows: 23 per cent of the concrete foundations were cracked, while 41 per cent of the brick foundations were cracked. Nor does this proportion fully represent the facts, for it was only in rare cases that the cracking of the concrete was of much importance; while, on the other hand, the damage to the brick foundations was often sufficient to endanger the stability of the house. The wooden foundations were rarely damaged. In cases where houses had especially heavy foundations, the damage was noticeably slighter. Heavy concrete foundations rendered structures almost immune to the shock. Not many heavy concrete bridges, for instance, were harmed. In a store that rests on the massive concrete foundation of a bridge crossing the creek in San Mateo, absolutely nothing was disturbed, altho the building overhung the creek about 7 feet. None of the many loose articles on the shelves fell, and a high top-heavy machine stood perfectly.

The falling of brick chimneys suggests the possible influence of the foundations upon these structures. Of all the chimneys on houses having wood foundations, 91 per cent fell; of those on houses with concrete foundations, 81 per cent fell; of those on houses with brick foundations, 88 per cent fell. A truer relation is given by taking merely those on the flat land at San Mateo and Redwood City, where the cases are strictly comparable. Of these the proportions in the same order are 93 per cent, 98 per cent, and 96 per cent. The disadvantage of brick foundations is further attested by the greater damage to plaster in houses built on them.

*Brick chimneys.* — In the region studied, the tops of 88 per cent of all the brick chimneys fell at the time of the earthquake. This proportion is for the whole region. The varying proportions in the different localities are shown in the following table:

Table showing the number of brick chimney & examined, with per cent which fell, from houses on various foundations.

Character of foundations.	SAN MATEO.		REDWOOD CITY.		BELMONT, HOMESTEAD, AND CARLOS.		BURLINGAME AND SAN MATEO HILLS.		TOTAL.		
	Chimneys examined.	Chimneys fell.	Chimneys examined.	Chimneys fell.	Chimneys examined.	Chimneys fell.	Chimneys examined.	Chimneys fell.	Chimneys examined.	Chimneys fell.	Per cent of chimneys fell.
Wood . . .	280	257	64	63	51	44	15	11	410	375	91
Concrete . . .	187	165	9	8	3	3	85	55	284	231	81
Brick . . .	256	242	10	9	27	24	110	88	403	363	28
Total . . .	723	664	83	80	81	71	210	154	1097	969	88

Besides the falling of the tops, a large proportion of the chimneys that suffered this loss, as well as a great many that did not, were injured or cracked at the base or somewhere within the house. Economically, the damage below the roof is the most serious, as it is difficult to remedy and is a menace to the safety of the building. Some chimneys crumbled away entirely. This happened most frequently to those built on the outside of the house, in which case they usually fell away from the house, doing little harm. This may be considered a point in favor of exterior flues, inasmuch as the wreckage to houses due to the chimneys falling through the roofs, as well as the difficulty of repairing interior flues, is avoided. On the other hand, the unsupported exterior chimneys show a greater tendency to fall. Ash-boxes at the bases of chimneys weakened them at these parts, and made them more liable to injury. Only 12 per cent of the tops of the brick chimneys remained standing, the reasons for their standing being generally found in the construction of the chimneys themselves. The use of cement and lime instead of simply lime mortar, accounts for the standing of many, although the use of cement

did not always insure their safety. Many that stood were found not to be built up from the ground, but to rest on shelves somewhere within the house. This method of building seemed to preserve the chimney intact in the majority of cases. A few chimneys owe their preservation to their low, solid structure above the roof; many did not fall because they were well-braced, either by being inclosed in a wooden casing or a coating of cement, or by being held by iron rods clamped into the brick. A striking example of the advantage of an iron rod as support was that of a 2-story house in San Mateo. This house had a brick foundation and a slender chimney 14 feet high, supported by an iron rod. The chimney stood perfectly.

A great many chimneys that stood well above the roof were badly damaged at the base or within the house, and many were cracked above the roof and shifted a short distance horizontally. The use of cement in the mortar saved the chimneys in some instances, but a common effect of the shock on chimneys so built was to crack them somewhere and make them fall in one piece. In this way solid masses of great weight were sometimes pitched on to roofs and other parts of buildings, and the result was much greater damage to the house than was caused by chimneys built with lime mortar. Chimneys laid with lime mortar generally broke in many pieces or fell as loose bricks. The use of cement below the roof was apparently helpful, as the chief danger to that part of the chimney is from cracking rather than from falling, and the cement is much less apt to crack than the lime. The use of lime mortar above the roof is better, unless the chimney is to be boxed and braced. The construction of boxes around chimney tops, and the bracing with iron rods, are two simple and efficient preventives to the falling of chimneys of which comparatively few have made use.

*Chimneys other than brick.* — Many of the small houses of San Mateo County use terracotta thimbles or chimney pots, in place of brick chimneys. Their efficiency against earthquakes is conclusively shown by the fact that a large proportion of them stood unhurt, even when built in several sections. From 90 to 95 per cent of these chimneys past through the earthquake without harm. Galvanized-iron pipes, and stove pipes used as chimneys, were likewise unhurt in most cases. The few chimneys that were built entirely of concrete proved to be much stronger than those of brick.

*Plaster.* — In almost all houses with plastered walls, the plaster was cracked more or less seriously or broken off in sheets. The plaster or stucco on the outside of houses was badly damaged. In the majority of the houses, some of the walls — usually not all — were seamed with small cracks which ran in every direction and frequently in lines parallel with the laths. In other cases the cracks were wide and the walls were in large part laid bare.

The second table on page 305 gives the statistics regarding the cracking of the plaster. The first column includes the cases in which the plaster was almost unhurt or only slightly cracked. Most of these buildings did not require replastering. The second and third groups include the buildings more seriously damaged. Replastering was necessary in the second and third groups. The plaster on the ceilings of houses was much less affected than that on the side walls, and in the majority of cases was unhurt. In 2-story houses the plaster was rarely damaged as severely on the second floor as on the first floor, and in wooden houses of three stories it was often observed that the plaster on the third floor was uninjured. This restriction of the damage to the ground floor may be due to the breaking of the plaster by short, sharp movements near the ground, which were translated above into the swaying of the entire upper story. That the plaster did not crack much on ceilings was probably due to the fact that the ceilings (and the floors above) were not subjected to so much strain because they moved as one piece. Thick coatings and varieties of hard plaster seem to have been less damaged. New plaster not yet dry was not affected in the few cases observed.

*Dishes, etc.* — There were few houses in which something did not move or fall a noticeable distance, and yet few in which everything moved or fell. There was little regularity, even in the same house, in the amount of movement of loose objects. Innumerable instances of seemingly capricious variation could be cited. The earthquake resulted in severe damage to breakables and heavy loss of dishes and bric-à-brac. Approximate figures as to the amount of such damage are given in the table on page 365. In houses where only a few dishes fell the damage was considered slight. Those losing about half of the breakables are shown in the second column, and all of the more severe cases are placed in column 3. The percentages are at best only approximate. In the valley about 40 per cent of the houses lost slightly, and 40 per cent lost heavily, the loss in the remaining 20 per cent being intermediate. On the hills 74 per cent of the houses lost but little, and even in other cases the loss was not great. Many dishes were saved by raised borders on shelves on which they were standing. It often happened that loose articles fell from the lower shelves in pantries, etc., and remained on the topmost ones.

*Windows.* — It is an interesting fact that out of a total of thousands of windows in the area covered by this investigation, only a few were broken. Leaving out of account the windows of houses that were thrown down, the total number broken by the shaking or compression of the walls, or in other ways directly due to the shock, was probably not greater than 40. In several nurseries only a few panes were broken in many glass-covered hot-houses. The same general fact holds true over the whole of the San Francisco Peninsula, and in other regions affected by the earthquake that were visited by the writer. The majority of the windows that were broken were in brick buildings. That the windows were subjected to great stresses is shown by the fact that many of those made of parts joined by lead bulged considerably, and many were thrown upward with sufficient force to break their locks. In about 20 per cent of the cases where windows were raised in this way the glass was broken.

*A resistant type of structure.* — The data collected in this region appear to show that a house, to withstand an earthquake, should be constructed about as follows: The building should be of wood, and a wooden sill should be bolted to a deep-laid concrete foundation, the top of which should be but little above the level of the ground. It should be ceiled with wood within. Shelves for dishes should be closed in with doors, or should at least have strips along the front edges. The chimneys should be laid with cement mortar and boxed from a foot or two below the roof to the top, and the parts above the roof should be braced with iron rods. The lower the structure the less strain it will IM Fubjirtrl to. Such a building would be practically proof against earthquakes having an intensity below X of the Rossi-Forel scale.<sup>1</sup>

#### THE MANNER AND DIRECTION OF MOVEMENT.

*Kinds of movements.* — The shock of the earthquake was heavy enough to cause almost everything to move somewhat, and heavy objects were displaced as often as lighter ones. *Uwrv wæ* many cases of inconsistency in the movements, such as the displacement of *htivv* article like; pianos and stoves, where frail cups or vases remained in place; or *nivh* as the difference in motion exhibited by articles standing side by side. In many cases chimneys were thrown a distance of 6, 10, 15, and even 20 feet; a vase was thrown K feet, an acorn 4 feet, milk 8 feet. Hanging things were set in motion, liquid\* were spilt, and loose articles tipped over.

Ff^anl mavrim-nts in many different places were attested by the fact that sliding y/uflemi<sup>2</sup> were rAL-æci several inches with such force as to break the iron latches that to M ihvm down IWihy these windows were jerked up by their weights, which Uoaa. m r. I!\* thrown down with force had the houses been subjected to sharp verti-

<sup>1</sup> *M. S. A. C. h.* reinforced *vuiu-n-is* structures are also of course eminently well adapted to resist earthquake shocks of high intensity. A. C. h.

cal movements. In Prince Poniatowski's house, which stands on the hills at an altitude of about 500 feet, a mile from the fault-line, all the windows — over 30 in number— were so raised. It is believed that all of the windows in this case were of the kind that are balanced by weights hanging within the frame. In many places on low land the same thing occurred. In one case a baby's cot jumped up and down, breaking its castors.

Bodies frequently assumed positions such as would have been imparted by twisting movements. This was true in the case of many houses, turrets, articles of furniture, hanging pictures, and chimneys. The apparent twists were both in the positive and the negative direction, and varied from a few degrees to 180 degrees. In the opinion of the writer, such positions were the result of a complication of movements rather than of a twisting motion. The twisted position of furniture was often ascribable to the rolling of the castors. Dishes, vases, etc., could easily change their orientation, especially if they were tipped up, as was frequently done. But the majority of articles were caused to shift their position horizontally, in one or more direct lines. A large number of houses slid on their foundations, dishes and books slid off their shelves, and but few things failed to change position.

*Movement of houses.* — One of the principal objects of this investigation was to find out in what direction houses moved on their foundations. Data were gathered concerning 842 wood, concrete, and brick foundations in regard to which it could be learned whether or not movement of the superstructure had taken place. Of this number 190, or 23 per cent, gave clear evidence of movement. In each case the direction and distance were tabulated. The directions are given in the following table. The distances are given in the first table on page 365.

Table showing direction of movements of houses on their foundations (total number of observations, 190).

Localities.	Group 1. Movements NW. and SW.				Group 2. Movements NE. and SE.				Group 1. Movements N. and S.		Movements in directions of Groups 1 and 2 combined.				
	NW.	W.	SW.	SW. and NW.	NE.	E.	SE.	NE. and SE.	S.	N.	NW. and NE.	W. and K.	SW. mid SE.	SW. and NE.	NW. and SE.
San Mateo . . . . .	25	23	40	18	8	*10"	10	2	4	4	....	2	3	5	5
Redwood . . . . .	6	8	1	....	1	....	5	....	1	2	....	....	....	....	....
Belmont, Homestead and San Carlos . . . . .	....	....	1	1	....	....	....	....	....	....	....	....	....	....	....
Burlingame and San Mateo Hills . . . . .	....	....	2	1	....	....	....	....	....	....	2	....	....	....	....
Totals . . . . .	31	31	44	19	9	10	15	2	5	6	2	2	3	5	5
Group totals . . . . .	125				36				8		17				
Group per cents . . . . .	G5				19				6		9				

Moved either SW. or NE., or in both directions, 31 per cent of total; moved either NW. or SE., or in both directions, 27 per cent of total.

The majority of houses that shifted moved southwest and northwest, or combinations of these directions. The west movements tabulated in practically every case were a combination of movement of the house over the edge of the foundation to the northwest and southwest equal distances, so that the effect was the same as from a single movement west. It was not known whether there had been a single shift west, or two at right angles southwest and northwest. The author inclines to the belief that there were two main movements causing houses to shift southwest and northwest, rather than one in an east and west line, inasmuch as so many of the movements were simply southwest or northwest, or not directly west. The movements tabulated in the southwest and northwest column are those cases in which both movements affected the house, one

predominating over the other. Grouping together all movements recorded as northwest and southwest and west, it is shown that 65.5 per cent of all the houses moving shifted in these directions. The second group of the table includes all movement in directions opposite to those of group 1 — that is northeast, east, and southeast. These make up 19 per cent more of the total. In the third group are included all those moving back and forth in the directions of groups 1 and 2, or partly in one main direction and partly opposite to the other main direction. These comprize 9 per cent. If, then, as the writer supposes, the west and east directions may be eliminated by being separated into their components, there will be 93.5 per cent of the total number that moved northwest, southwest, northeast, and southeast.

*Movement of chimneys.*—The great majority of chimneys in the region under discussion are of brick. They are of many different shapes and sizes, in different positions on the roofs, of various materials, and are affected by structural variations and by age. They could not be expected to show perfect consistency in the direction of fall, but statistics were gathered in order to find out the tendency of the majority and their value as indicators of direction and intensity.

In the following table the brick chimneys are grouped according to whether they fell in the direction of the slope of the roof on which they stood, obliquely, or at right angles to this; directly opposite to this, up the roof; or according to whether they jumped. Those not falling form another group, of which a few shifted horizontally. The majority of streets on which the houses enumerated in this paper are situated, run in northwest and southeast, and southwest and northeast directions, so that the slopes of roofs are generally in those directions. More slope northwest and southeast than southwest and northeast. These directions of roof-slope make themselves apparent in the table, inasmuch as the slope of the roof exerts a marked control over the direction in which a chimney falls.

Table showing the directions in which brick chimneys moved.

Chimneys which fell down the roof, <i>i.e.</i> with the roof-slope.			Chimneys which fell in a direction oblique or opposite to the roof'slope, and those shifting or jumping.						Total movement in all directions.	
Direction.	Number fell.	Per cent by directions.	Number falling obliquely to roof.	Number falling opposite to roof.	Number jumped.	Number shifted.	Total.	Per cent by directions.	Total number chimneys moved.	Per cent moved by directions.
NW.	175	31	8	4	10	5	27	10	202	24
SW.	121	22	15	7	8	1	31	12		
NE.	102	18	19	3	4	.....	26	10	128	15
SE.	133	24	14	7	2	2	25	9	158	19
NNW.	1	0.25	15	.....	1	.....	16	6	17	2
WNW.	1	0.25	15	.....	.....	.....	15	6	16	2
WSW.	.....	.....	6	.....	1	.....	0	2	7	1
SSW.	1	0.25	13	.....	.....	.....	13	5	14	2
SSE.	.....	.....	12	.....	.....	.....	12	4.5	12	1
ESE.	.....	.....	10	.....	.....	.....	10	3	10	1
ENE.	.....	.....	8	1	.....	.....	0	3	9	1
NNE.	1	0.25	12	1	.....	.....	12	5	14	2
W.	5	1	21	1	1	.....	23	9	28	3
E.	7	1	10	.....	1	1	12	4	19	2
N.	5	1	8	.....	1	.....	9	4	14	2
S.	8	1	19	.....	2	.....	22	11.5	30	4
Total	560		205	25	31	9	270			
Southwest-northeast, 40 p. ct. Northwest-southeast, & 5 p. ct.			Northwest-southeast, 19 p. ct. Southwest-northeast, 22 p. ct.						Northwest-southeast, 43 p. ct. Southwest-northeast 33 p. ct.	
> 80 per cent of all that fell. 22 per cent of all that fell. 3 per cent of all that fell. 3 per cent of all that fell. < 7 per cent of all that did not fall.			Fell in known directions. . . . . 821 Caved away and fell in doubtful directions. . . . . 101 Total fell . . . . . 922 Shifted . . . . . 9 Stood without falling . . . . . 118 Total number of chimneys . . . . . 1049							

It will be seen from the preceding table that out of a total of 922 brick-chimneys that fell, 60 per cent went down the roof, while only 3 per cent fell in the opposite direction; 22 per cent fell obliquely, and 3 per cent with a leap apparently regardless of the roof. The predominance of the northwest and southwest directions, however, does not seem to be wholly due to the roof-slope. The table shows that in each division the northwest-southeast and northeast-southwest directions of movement are in the majority, even tho the chimneys have fallen in a direction contrary to the slope of the roof. The evidence here is not of the best, but there certainly seems to be a tendency toward motion in the same directions as those dominant in the case of the houses themselves. It may be supposed that chimneys fell in those directions owing to the movement of the house, but the majority of chimneys falling came from houses that were not dislocated.

The evidence of the chimneys falling obliquely, up the roof, shifting, and jumping was the best, since they moved without regard or in opposition to structural influence. Among these much the largest number of movements in any two directions were northwest and southwest, and the next largest number just opposite. The northwest-southeast and southwest-northeast movements, then, were in the majority, making a total of 41 per cent, while a majority of those remaining moved in directions intermediate.

*Movement of dishes, books, etc.* — Such loose articles as books, dishes, bric-à-brac, and lamps are, as a rule, free to fall or slide as they will, but in this region, especially in the town of San Mateo, the shelves on which many of them stood faced northwest, southwest, northeast, and southeast. The possible directions for falling in such cases were limited and this detracts somewhat from the value of the figures in the table.

Table showing percentage of directions in which dishes moved.

Direction.	Per cent moved, by directions.		Direction.	Per cent moved, by directions.	
NW.	22 \	491 } 89	W.	4 \	7 } 11
SW.	27 /		E.	3 /	
NE.	20 \		N.	151	
SE.	20 /		S.	2.5 /	

SW. to NE., 47 per cent; NW. to SE., 42 per cent.

Of objects overthrown, 89 per cent fell in one of these four directions. Tho many of the movements were determined solely by the direction in which the shelves faced, still the small number of movements in intermediate directions favors the idea that northwest and southwest and opposite movements predominate, for many of the cases recorded were of articles free to fall in any way whatsoever, and others were of articles that slid some distance along shelves without falling off. The east and west movements were more important than those north and south, showing a tendency in that way.

As to the cases in which dishes remained in position without appreciable shift on shelves facing in the four main directions of movement, the southwest-facing shelves were most of them left empty, and there was a much greater number of cases in which dishes remained stationary when it seemed natural for them to fall northwest, northeast, or southeast.

The case of a town library is especially worthy of mention: of books facing southeast, none fell; of those facing northwest, a few fell; of those facing southwest, all fell.

*Movement of furniture, etc.* — These data include facts concerning the direction of movement of pianos, stoves, tables, bookcases, beds, bureaus, counters, cases, mantel-pieces, safes, deposits of merchandise, and the like. These were generally free to move in all or most directions. The way in which the furniture was moved was learned at every house, and the results tabulated by regarding every direction of movement in any one house as a unit. Each unit, or case of movement, therefore, usually represents several individual movements.



Table giving data in regard to the moving of furniture.

Directions.	Percentage of cases in which furniture, etc., moved.	Number of cases in which articles, such as pianos, stoves, etc., moved.	Directions.	Percentage of cases in which furniture, etc., moved.	Number of cases in which articles, such as pianos, stoves, etc., moved.
NW.	19	14	SSE.	2	..
SW.	31	6	ESE.	0.3	..
NE.	18	4	ENE.	0.3	..
SE.	11	6	NNE.	0.3	..
NNW.	13	.	W.	5	*5
WNW.	13	2	E.	3	2
WSW.	20	..	N.	2	2
SSW.	13	..	S.	3	3

Here again the movements in northwest, southeast, southwest, and northeast directions far outnumbered all others. The total movements in these directions is 79 per cent. There were many cases of movements in directions slightly oblique to these, but tending the same way, which, if included, would swell the total. The southwest direction was much more frequent than the northwest, and the movements along southwest-northeast lines were much in excess of those at right angles. The west and east shiftings were more frequent than those to the north and south. The pieces of furniture moved in various ways, tipping over, sliding, and jumping. The movements were often back and forth. There is an apparently authentic case of a china closet tipping to the northwest, resting at an angle of about  $60^\circ$  against an obstruction, and tipping back to its original position. The number of heavy pianos, stoves, and safes which were moved is given in the preceding table. Sixty-six per cent of them were moved northwest and southeast and southwest and northeast. The evidence is especially good in such cases as the sliding of cash registers and scales on smooth counters, which in several instances went northwest, southwest, and southeast. The ornamental top of a soda fountain, balanced and free to fall any way, fell toward the southwest.

*Experiences and testimony of people.* — An earthquake comes and goes so suddenly and unexpectedly, and there are so many things to think about, even when one is able to formulate any thoughts whatever, that the description by people of the manner in which they felt the shock is apt to be only fragmental at best. It is the almost universal testimony in the San Mateo region that the first shock was followed by a lull, and that this was followed by a renewal of the motion in a different direction. Many state that the shock following the momentary lull was the heavier of the two. As to which of the two movements along lines northwest-southeast and southwest-northeast came first, little evidence has been forthcoming. Persons who agreed in regard to there being two successive directions of vibration differed as to which preceded. There were two cases of the spilling of liquids noticed by persons, and in both the statement was made that the liquid splashed toward the northwest at the first shock. In one of these cases the northwest splash was followed by one toward the southeast. A lady who was awake when the shock came said that things on the southeast side of the room began falling first. A jeweler declared that he was satisfied, from the movement of his pendulums, that the main shock was southwest and northeast. Two people were thrown out of bed in the same house, one of them being thrown northeast, the other southwest. One of these, after getting up, was thrown southeast from a standing position.

*Spilling of liquids.* — A form of evidence that could not be influenced by artificial position of any kind is that of the splashing of liquids. It is, however, evidence that is difficult to get at, partly because the signs of direction are so transient, and partly because even when they remain long enough to be seen, they are apt to be either carelessly or not at all observed. The 30 cases of spilling that were considered trustworthy and were recorded point to movements northwest-southeast and southwest-northeast.

Table showing directions in which liquids spilt.

Direction.	No. of cases of spilling.	Per cent, by directions.
NW. . . . .	6	20
SW. . . . .	6	20
Both NW.-SW. . . . .	1	3
NE. . . . .	4	14
SE. . . . .	4	14
Both NW.-SE. . . . .	4	14
Both SW.-NE. . . . .	5	17
ENE. . . . .	1	
W. . . . .	1	
Both E. and W. . . . .	1	
Both ESE. and WNW. . . . .	1	3
Total . . . . .	30	

SW. or NE., or both SW. and NE., 51 p. ct.; NW., or both NW. and SE., 34 p. ct.

In 20 per cent of the cases the liquid spilt northwest; in 20 per cent southwest; and in 3 per cent in both directions, making a total in these two ways of 43 per cent. Fourteen per cent spilt northeast, and 31 per cent northwest-southeast and southwest-northeast, in combination. This makes a total of 88 per cent in which spilling took place along the same lines in which movement in all previous cases predominated. The rest of the cases of liquids spilling tended the same way, none having gone north or south. The water in a reservoir was observed by one man at the time of the shock. He said the water seemed to move in waves toward the northeast, and that it splashed high on the northeast side of the reservoir. Others declared that waters were calmed by the quake. Tanks of water were repeatedly either wholly or partly emptied by the splashing of the contents. One lady states that her goldfish were thrown out of a little pool with the water, toward the east-northeast and west-northwest.

*Movement of various other bodies.* — This paragraph includes all important items of evidence that have not found a place in previous sections. It covers cases of falling, leaping, and sliding of towers, tanks, porches, pillars, underpinnings, gate-posts, arches, roofs, and the pulling apart of walls and partitions, besides the movement of many smaller articles. The evidence in most of these cases is especially good. For instance, a heavy marble slab on a counter slid lengthwise toward the northwest. A derrick which was leaning northeast was thrown toward the southwest. The following are the percentages in over 50 such cases: southwest, 35 per cent; northwest, 24 per cent; southeast, 17 per cent; northeast, 11 per cent; a total of 87 per cent for these 4 directions, while the other 4 directions, north, south, east, and west, total only 13 per cent of the movements. This is more evidence tending to the same conclusion as before; namely, that the southwest and northwest movements, and their opposite directions, far outnumber all others. In general, things that are thrown or that fall or slide freely furnish the best criteria for judgment as to the direction. The above list is largely made up of data of this kind. The cases of pulling apart of walls included are very few, for in the majority of instances in which parting of walls occurs the action is dependent on too many other factors.

*Predominance of northwest and southwest movements.* — It has been shown that the movements northwest and southwest, and those opposite, greatly exceed in number those in all other directions; and there is no question as to the predominance of the first two over those opposite to them in almost every case. It is clearest in the movement on foundations and the splashing of liquids. Evidence in regard to relative amounts

of movement in the first-mentioned directions and in those opposite seems to be best in the case of foundations, since loose articles may often have been thrown in the direction of an earthquake thrust, while houses moved opposite to it. The supposition is that houses usually shifted opposite to the thrust. Furthermore, it must be borne in mind that the contents of a building may be influenced by the movement of the building, rather than by the direct earthquake thrust itself, and thus give results pointing in the opposite direction.

*Cause of shifting.* — From the fact that northwest and southwest displacements were of most frequent occurrence, it seems likely that the main earthquake movements were southeast and northeast.

The fault which is believed to have caused the earthquake runs in a direction about N. 40° W., and passes within 3 miles of San Mateo. It will be noted that the dominant directions of movement were parallel and at right angles to the fault-line.

Evidence appears to show that in any one direction there was a succession of thrusts. In one instance, a bureau was jerked by successive small movements a distance of 6 feet toward the northwest. The course of such moving objects can often be traced by the marks left in dust. Some objects that were moved had returned to their original position when the end of the shock came.

*Relative intensity of the main movement.* — Considering only the northeast-southwest directions and those at right angles to them, we find that of all the houses that moved on their foundations, 31 per cent shifted southwest and northeast, and 27 per cent northwest and southeast. (See table on page 359.)

Of the chimneys that fell obliquely or upward with reference to the slope of the roof or that jumped or shifted, which gave the most trustworthy evidence in cases of falling chimneys, 22 per cent moved southwest and northeast, and 19 per cent northwest and southeast. The figures for all the chimneys give the predominance to movements in the northwest and southeast directions, but this fact is not significant, since the majority of roofs sloped in those directions.

Among the cases of liquids spilt, the southwest-northeast movement was greatly in excess of that northwest and southeast, 51 per cent of the total spilling in the former ways, and 34 per cent in the latter.

In addition to the evidence of the figures in other tables, that given in the table on page 361 may be cited. Forty-seven per cent of the dishes and similar articles went southwest and northeast, while 42 per cent went northwest and southeast. The same fact is indicated by the dishes that faced in these directions and did not fall. Fifty-eight per cent of the cases in which dishes remained standing on the shelves, when they were at liberty to fall in one or more of these ways, were cases in which they failed to fall northwest or southeast. According to the table on page 362, in 49 per cent of the cases of furniture movement the direction taken was either southwest or northeast, or both; whereas it was northwest or southeast in only 30 per cent of HUCI cases.

The following table enumerates the cases in which houses moved a distance of more than 0.25 inch on their foundations; in other words, the worst cases of the kind. It gives the sum of the distances moved in each direction.

Among the most serious shifts, those to the southwest predominate slightly in number and distance over the northwest ones, but owing to the excess of southeast movements over those to the northeast the percentages for the combined opposite movements are just the same — 37 per cent in each case. Numerous houses shifted both southwest and northwest, but different distances each way. In exactly half of the cases the movement southwest was greater, and in the other half that of the northwest movement was in excess, while the average distance moved either way was the same.

*Number of cases in which houses moved measurable distances on their foundations in different directions, and average distance moved.*

Direction.	Number of houses moved.	Average distance moved (inches).	Total moved and percentage by direction.		Average distance moved (inches).
				Per cent of total.	
NW.	31	1.19)	84	69	1.15
SW.	39	1.05/			
W.	14	1.36)			
NE.	6	1.91)	29	24	1.39
SE.	14	1.29)			
E.	9	1.22)			
N.	4	2.37)	9	7	1.50
S.	5	.80/			
Total . .	122	1.24			

Southwest-northeast, 45 = 37 p. ct. of total; northwest-southeast, 45 = 37 p. et. of total. The entire number moved in first three and opposite directions was 113, or 93 p. ct. of total.

INTENSITIES.

The houses covered by this study may be grouped in three divisions, according to locality: those on the hills at Burlingame and San Mateo heights; those at Belmont, Homestead, and San Carlos, which are partly on the level valley land and partly on the low hills; and those at San Mateo and Redwood City, on the valley-floor. The data indicate strongly that the intensity of the shock was less on the hills than on the flat, in spite of the fact that the houses on the hills were nearer the fault-line. In fact, several houses on the rock-formed hills very near the earthquake fracture did not give evidence of any greater intensity than those at San Mateo.

The Buri-Buri Ridge, as the hills are called, is composed of an old and very much compacted series of sedimentary rocks, sandstone, shale and jasper, and of serpentines. Moreover, they are not deeply covered with soil, so that they form a strong foundation for the houses.

The percentage of houses that moved on their foundations on the hills was 6 per cent; and at Belmont, etc., 3 per cent moved, as against 27 per cent at San Mateo and Redwood City. This is shown in the table on page 355. Among the very few houses that shifted on the hills and in the Belmont region, only 4 or 5 moved an appreciable distance, while in a majority of cases in the valley the movement was considerable.

From the figures given in the table on p. 356 it appears that of the chimneys, 73 per cent fell on the hills, 88 per cent in the intermediate settlements, and 92 per cent in the valley. The intensity of the shock, as shown by the amounts of falling of dishes and cracking of plaster, was greater in the flat country. The following table gives the percentage in these cases. Of course the classification of the damage is very arbitrary and the figures at best are but indicative. Of cases recorded in which furniture failed to move appreciably in houses, 90 per cent were on the hills.

*Degrees of damage to plaster and household articles on hills and low lands.*

AMOUNT or DAMAGE.	SAN MATEO AND REDWOOD.			BUCKINGHILL HILLS, ETC		
	Slight.	Medium.	Great.	Slight.	Medium.	Great.
Percentage in cases of cracking of plaster	40	30	30	79	11	10
Percentage in cases of falling of dishes, etc., in varying amounts	40	20	40	74.3	23.3	2.3

The testimony is good in all cases that structures on the hills suffered less severely from the earthquake than those on the plain. If a large amount of similar data could be collected on the low, alluvial, often marshy, flat land bordering the bay, it would probably be shown that the movement there was still more intense. Houses, however, are not frequent there. In low bottom-land there were indications of great intensity, and especially in the case of ground artificially filled in. A good example was given by the electric railroad track a few miles north of San Mateo, shown in plate 97c, D. It was built over the low land on a heavy, but loose, embankment of earth and stone. At one place this roadbed was shaken apart between the rails, and a crack from 1 to 2 feet wide and extending down many feet, nearly if not quite to the level of the valley, was formed in it for a distance of over 1,000 feet. It ran northwest and southeast, parallel with the road, and thruout that stretch not one of the heavy steel rails was left unbent. One 30-foot rail that was examined had been bent 2 feet horizontally and 10 inches vertically. Such wrecking of railroad tracks occurred wherever the underlying foundation was loose, but the stretches of track on solid ground were not affected. The low, muddy land along San Francisco Bay, east of San Mateo, was seamed with cracks by the earthquake.

#### CONCLUSION.

The following are the main conclusions arrived at in the course of the work:

1. It is evident that much of the damage to houses, as well as to their contents, could be avoided by judicious construction. The disadvantages of certain classes of structure should be acknowledged, and search made for more successful styles. Houses practically earthquake-proof can be built easily and cheaply.
2. The dominant directions taken by moving bodies during the course of the earthquake shock were southwest and northwest, with movements northeast and southeast only second in number. There appear to have been felt in this region two main thrusts or sets of movements that emanated from the fault-line in southeast and northeast directions.
3. The shock was less heavily felt on the hills than on the level land. The lower slopes were affected in an intermediate degree. The difference in the two extremes was probably almost as much as one degree of intensity in an earthquake table of 10 units.

## DIRECTIONS IN THE TOMALES-BOLINAS DISTRICT.

BY G. K. GILBERT.

The greater number of my notes as to direction of motion pertain to the shifting of houses which left their foundations. Most of the houses in this district which were thus shifted stood on light, vertical, wooden piers or props, and fell from their props in shifting. The direction of falling was so frequently downhill as to show that the slope of the ground was an important factor, and this fact leads me to give little weight to data of this character. There were, however, a few houses which, resting upon flat, unyielding foundations, were shifted horizontally upon these, and their evidence is of greater value. I think also that some weight should be given to the dominant direction in which houses of a group were thrown from their supports.

Other data as to direction are found in the falling of men and animals, and these seem to me of value wherever a dominant direction affected a group of individuals. The direction of fall of a single individual might readily be conditioned by muscular reactions, and thus give little evidence as to the direction of the strongest tremor.

I am led to question evidence from the shifting of furniture and the throwing down of objects on shelves, because in every instance the direction of vibration of a building appeared to be controlled partly by its structure. In view of these considerations, I regard the greater number of my observations on direction as of little significance, and do not report them.

The clearest data as to direction are at Inverness. While there was much variety in the direction of motion of houses at that locality, it was quite clear that the dominant direction was westward. This also was the direction toward which 4 out of 5 water-tanks were shifted, and it was the direction toward which the mud on the bottom of Tomales Bay was moved. The locality is within less than 1 mile of the fault-trace and is on the southwest side.

At Point Reyes Station, situated 0.25 mile northeast of the fault-trace, the dominant direction of shifting was southward, and an exceptionally definite record was made by the school-house, which rested on a firm, flat foundation and was slid toward the south.

At Olema, 2 miles southeast of Point Reyes Station and similarly related to the fault-trace, the dominant direction of motion was southwest, or toward the fault, the best single instance being that of a pool of water which spilt in that direction.

At Dipsea Inn, 0.66 mile northeast of the fault, a pier running northeast from the spit was wracked toward its outer end. A line of telephone poles crossing the lagoon from the end of the pier was slanted in the same northeast direction. In the Inn objects were thrown southwest, and of three cottages injured two were shifted or wracked to the southwest. On the mainland nearby a part of Mr. Morse's pier was wracked to the southwest. Collectively these facts indicate a dominant vibration to and from a northeast direction.

At Willow Camp, close to the east angle of Bolinas Lagoon and about a mile northeast of the fault, several houses moved short distances toward the southeast.

These various directions are platted in fig. 65.

## DIRECTIONS INDICATED BY MONUMENTS IN CEMETERIES.

Prof. F. Omori attempted to determine the directions of the earth's vibrations by a statistical study of the thrown monuments in the cemeteries south of San Francisco. The results of his investigations are shown graphically in fig. 66, in which it appears that the greater number of monuments were thrown in the quadrant between northeast and southeast. The mean direction of overthrow is N. 76° E., which is regarded

as the direction toward which the greatest horizontal displacement took place due to vibration. Other observations on the directions of the vibratory movement may be found in Professor Onion's paper.<sup>1</sup>

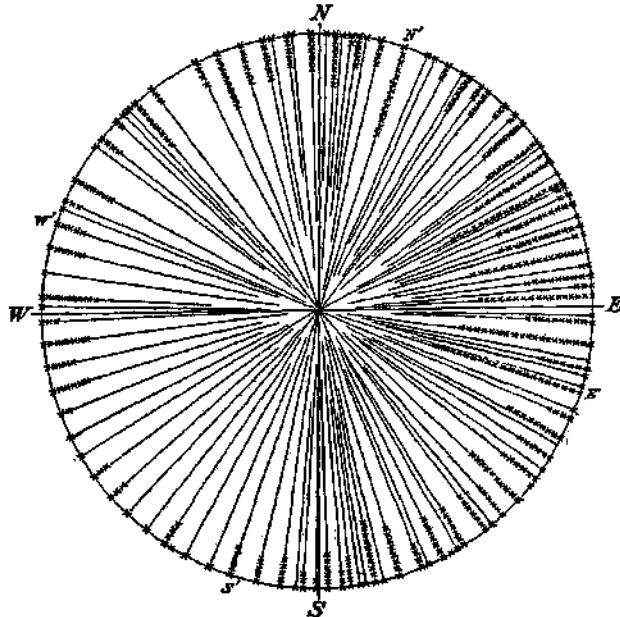
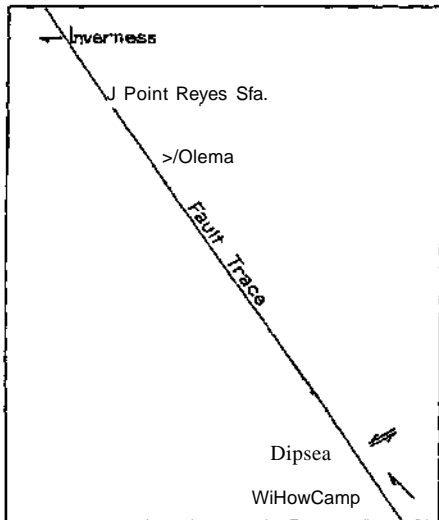

FIG. 65.—Directions of earthquake motion. FIG. 66.—Statistical representation of the directions of fall of monuments in the cemeteries south of San Francisco. Each x represents a monument which fell in the direction indicated by the radius on which the x is placed. After Omori.

Preliminary note on the cause of the San Francisco earthquake of April 18, 1906. Bull. Imo K I. C, Vol. I, No. 1.

## MARINE PHENOMENA.

*The effect of the earth movement on the sea-level.* — In earthquakes along coastal regions the waters of the ocean are usually affected, particularly if there be a displacement of the sea-bottom. If the displacement has a considerable vertical component, so that one portion of the sea-bottom is dropt relatively to an adjacent portion, the ensuing displacement of the prism of water over the region affected will generate a periodic wave, which will cause the water along the coast to rise and fall with more or less disastrous results. If the dropt portion of the sea-bottom is on the landward side of the fault upon which the displacement occurs, the wave will be greater for the same amount of displacement than if the drop is on the seaward side. If, however, the vertical component of the displacement is quite small, and the movement is chiefly horizontal, as in the case of the fault of April 18, 1900, the sea-wave will be correspondingly insignificant.

The bottom of the Gulf of the Farallones, which was traversed by the fault from Bolinas Lagoon to Mussel Rock, comprizes the inner shallower portion of what is known as the 100-fathom plateau off the coast of California. This plateau stretches seaward, with an average breadth of 22 miles, immediately off the short line of coast from Pigeon Point, in latitude  $37^{\circ} 11'$ , to the mouth of Russian River, in  $38^{\circ} 20'$ , a distance of about 80 geographic miles. The area of this part of the plateau is about 2,500 square miles, which includes the area of the Gulf of the Farallones, about 1,200 square miles. On it lie the Southeast Farallones, the North Farallones, Noonday Rock, and the Cordell Bank, having a northwest and southeast bearing thru 30 geographic miles. The line projected southeastward strikes Pigeon Point. (See map No. 4.) The summits of the Farallones rise as much as 340 feet above the sea; Noonday Rock has 3 fathoms of water over it, and the Cordell Bank has 19 fathoms. Inside of these islets there is a very uniform bottom of sand, with a gradually decreasing depth of water toward the shore. Outside of the islets the grade of the bottom rapidly increases. The 100-fathom line reaches 5 miles to the southwest of the Southeast Farallones; thence it is 10 miles to 500 fathoms and 29 miles to 1,728 fathoms.

There is no means of directly ascertaining the amount of the vertical component of the fault of April 18 for those portions of the fault-trace which lie on the sea-bottom across the Gulf of the Farallones or in the region to the northward. But where it traverses the land to the south of Mussel Rock, there is no evidence of vertical displacement; and to the north of Bolinas Bay, while there is evidence of an uplift on the west side of the fault, that uplift is slight, not exceeding 1 or 2 feet. The absence of a periodic wave at the Golden Gate indicates that the vertical displacement on that segment of the fault which crosses the Gulf of the Farallones, if there was any, was very small. While there was no periodic wave of the oceanic water generated by the horizontal displacement of the sea-bottom, there was an interesting disturbance of the level of the sea, shown by the tidal gage near Fort Point on the south side of the Golden Gate, which is probably to be classed with the secondary phenomena arising from the displacement.

The tidal gage yields a record known as a marigram, upon which is chronologically indicated the rise and fall of the water in the Golden Gate with the incoming and outgoing of the tide. The record is said to be sensitive to the impact of waves breaking upon the bar outside the heads distant some miles from the gage. It is also sensitive to the conflicting volumes of water from the north and south parts of the Bay, when these are striving for mastery on the fading tide. Former submarine earthquakes in distant parts of the Pacific have generated waves which have been recorded on the



marigram at the Golden Gate. The marigram near Fort Point, for April 18, 1906, shows (fig. 67) a depression of the water-level in the Golden Gate at the time of the earthquake, or rather a little subsequent to that event. The amount of the depression was slightly in excess of 4 inches. The marigram shows a blurring of the pencil mark from the direct action of the earthquake agitation, and this bearing serves to give approximately the time of the shock. It shows that the running clock of the gage was probably too slow, and that the depression of the water-surface did not begin instantaneously, but followed after an interval which may have been from 9 to 10 minutes. Before the shock the gage had had a small vertical movement, ascribed by the officers of the Coast and Geodetic Survey to an imperfect oscillation across the Golden Gate. This minor vertical movement continued during the drop in the level of the water after the shock. The time for the lowering of the water was 9 minutes, as near as can be read from the marigram. It immediately began to recover, and the record shows that the water level rose without minor oscillations, to the normal level within 7 minutes, the total interruption in the normal marigram curve due to this depression being 16 minutes. After full recovery to normal level, the depression was not followed by a complementary rise of the water-surface, and in this sense the movement was not periodic. The minor oscillations referred to above ceased when the maximum depression was reached, and do not appear in their characteristic forms on the marigram curve for some hours after. They were replaced, however, after 6 o'clock, by 2 or 3 oscillations having a period of about 40 to 45 minutes and an amplitude of 1 to 2 inches. These probably correspond to oscillations in San Francisco Bay.

The Tidal Division of the Coast and Geodetic Survey very kindly computed the time which would be required for a wave generated at the fault-line on the bottom of the Gulf to reach Fort Point, and found that it would require 9 minutes, on the assumption that Fort Point is 6 statute miles distant from the fault-trace in a direction normal to it. The position of the gage is, however, 1.3 miles distant from Fort Point within the Golden Gate, so that the time necessary for the wave to reach the gage would be somewhat longer. Now the time at which the gage began to fall is between 9 and 10 minutes

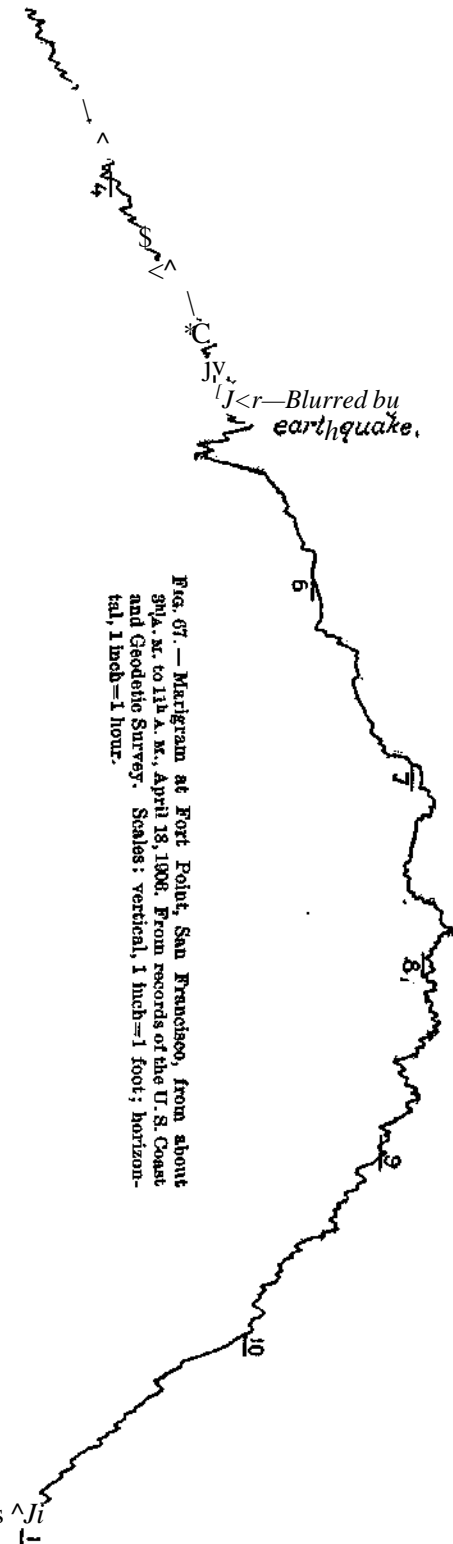

Fig. 67.—Marigram at Fort Point, San Francisco, from about 9 P.M. to 11 A.M., April 18, 1906. From records of the U. S. Coast and Geodetic Survey. Scales: vertical, 1 inch=1 foot; horizontal, 1 inch=1 hour.

after the first interruption and blurring of the record by the shock itself, and this coincidence in time suggests that the fall in the water near Fort Point was due to a negative oscillation generated at the line of the fault. The effect produced would have been brought about had there been a slight drop of the sea-bottom on the outer side of the fault. But there is independent evidence, to the north and south of this particular segment of the fault, that there was no drop on the west side, so that this explanation can not very well be entertained.<sup>1</sup> It is also possible that the effect observed might have been brought about by a slight expansion of the confines of the Gulf of the Farallones, due to the differential movement along the fault, but this would not explain the coincidence in time. The period of the east-west oscillation of the waters in the Bay of San Francisco, between West Berkeley and Fort Point, has also been computed by the Tidal Division of the Coast and Geodetic Survey to be about 40 minutes. This agrees fairly well with the two or three oscillations recorded by the gage after 6 o'clock, and indicates that the drop of the water-surface outside of the Golden Gate generated an east and west oscillation in the Bay of San Francisco.

Tidal observations conducted at Fort Point for a period of 1 year from the date of the earthquake indicate that there was no change of the relative altitude of sea and land at that point, as compared with the conditions prevailing during the 3 years preceding. A review of the observations for the past 9 years, by the Coast and Geodetic Survey, reveals, however, the interesting fact that in that period of time there has been an apparent subsidence of the coast at that point of 4.8 inches, practically all of this having been accomplished in the first 6 years of this period. There has been no movement in the last 3 years. (April 18, 1907.) The only other tidal gage maintained on the coast of California is that at San Diego, and the marigram obtained there shows no abnormal movement of the surface of the sea referable to the earthquake.

The only other report indicating that the level of the ocean was affected along the coast is by W. W. Fairbanks, of Point Arena, who says: "I have endeavored to learn of any unusual action of water along the sea-coast, and can relate but one instance of anything approaching the character of a tidal wave. On the day of the shock I traveled by wheel and on foot from Albion to Point Arena, 25 miles. At the mouth of Navarro River, at 8 o'clock on the morning of the 18th, I learned from reliable sources that a section of about 10 acres of low, flat land about the mouth of this river was entirely submerged for some minutes immediately after the shock."

*The shock felt by ships.* — Information regarding the perception of the shock on ships at sea or in harbors has been collected by Prof. George Davidson, and the following notes are chiefly the result of his inquiries:

The XI. S. T. S. *Pensacola*, moored to the pier at the U. S. Naval Training Station, Yerba Buena Island, San Francisco Bay, felt the shock on the morning of April 18, 1906. Surgeon L. W. Curtis reports that while in bed on the *Pensacola* he felt a vibratory shock lasting about 30 seconds, with one heavy jar about the middle period of the shock. A gentle rumbling sound coincided with the shock. The phenomenon closely resembled vibrations which are at times set up in the ship's hull on starting the dynamo, and it was mistaken for that, tho much more active and exaggerated than ever before observed. The vibration shook down some loosely piled books and papers from a table.

<sup>1</sup>This explanation is, however, advocated by Prof. H. F. Reid. In a note received while these pages are in proof he says: "If a depression occurred on the western side of the fault-line, extending for some distance to the westward, it would start a wave of depression towards the Golden Gate which would take 9 minutes to reach Fort Point and this is just about the time recorded by the gage. The time necessary for the recovery to normal level would depend upon the extent of the area depressed. If this were a narrow block, a wave of elevation would follow quickly upon the wave of depression and we should have a rapid elevation of the tide-gage above its normal position. As no such wave appeared and recovery was very gradual we must suppose that the deprest area extends for some distance to the westward, so that the recovery was slow. This is the only explanation so far offered, that would produce the effects observed."

The pilot-boat *Gracie S.* was lying in 18 fathoms of water near the lightship off the San Francisco Bar. She was suddenly struck by a seaquake which caused her to quiver as if the chain were running out of the hawser pipe. When the pilot boarded the German Cosmos steamship *Nyada*, the captain reported that his vessel had been shaken as if she had struck on rocks. The pilot-boat *Pathfinder* was lying in the vicinity, in 20 fathoms, and reported the same effect.

The steam collier *Wellington*, inward bound, between Fort Point and Point Diablo, in 50 or 60 fathoms, reported that the vessel was struck as if she were upon rocks. (Personal report of Captain Hayes, of the Board of Pilots.)

The steamer *Alliance*, off Cape Mendocino, reported by Mr. H. H. Buhne, of Eureka: The captain said she was struck a hard blow, as if she had run on a rock at full speed; time, 5<sup>h</sup> 11<sup>m</sup>. Mr. Buhne states that all ships in the harbor at Eureka felt the quake, but in South Bay it was heaviest. One vessel was hurled against the wharf time and again, throwing down piles of lumber and shingles.

The schooner *Joltn A. Campbell* felt the shock at sea, off Point Reyes. The following is a memorandum of the event by Capt. C. J. S. Svenson: "Ship's local apparent time April 18, 1905, 5<sup>h</sup> 15<sup>m</sup> A. M. Lat. 38° 00' N. Long. 126° 06' W.; 145 miles true west of Point Reyes. Weather fine; sky clear; wind fresh from north-northwest; sea moderate; ship's course southeast; speed 7 miles per hour. The shock felt as if the vessel struck lightly forward and then appeared to drag over soft ground, and when aft a slight tremor was felt; the whole lasting only a few seconds." The depth of water in the vicinity of the ship's position is 2,400 fathoms.

The steamship *National City* was approximately in lat. 38° 24' N. and long. 123° 57' W; 29 geographical miles distant from the nearest point on shore and about 31 miles from the fault-trace along the valley of the Gualala River. The vessel felt the shock at 5<sup>h</sup> 03<sup>m</sup> A. M., April 18, 1906, ship's time. James Denny, the chief engineer, supplies the following comment: "The ship seemed to jump out of the water; the engines raced fearfully, as though the shaft or wheel had gone; then came a violent trembling fore and aft and sideways, like running at full speed against a wall of ice. The expression 'a wall of ice' is derived from my experiences in the Arctic." In this vicinity the chart has several soundings, as follows: 911 fathoms over clay and mud at 11.5 miles on the line to Gualala Point; 1,586 fathoms over clay and ooze 8 miles north by compass; 1,821 fathoms over clay and ooze 14 miles N. 54° W. by compass.

The wharfinger at Santa Cruz reports that he heard a rumble before the shock, coming from the southeast, and saw the seismic wave traveling shoreward, causing a great rattling and crashing when it struck the town. Two distinct sets of vibration were felt, the latter being the harder. There was very little surf, the water looking like that in a tub when jarred. The wharf, extending southeast, seemed to pitch lengthwise. A steamer between Santa Cruz and Monterey, also one at Monterey wharf, felt the shock; it jarred them as if they had struck bottom.

*Shocks felt at sea subsequent to April 18, 1906.* —The ship *Alex Gibson*, at 7<sup>h</sup> 05<sup>m</sup> P. M. August 8, 1900, when in lat. 25° 35' N., long. 110° 06' W., experienced a tremendously heavy seaquake, lasting about 40 seconds and shaking the ship from stem to stern as if she were bumping over a ledge of rocks. It shook tools out of the racks in the carpenter shop; throw pots and pans down in the galley, cups and pitchers from hooks in the pantry, and all lamp glasses off the lamps. The crew came running aft not knowing what was the matter, and the captain thought the yards were coming down. The sea at the time was perfectly smooth, the wind light from the southwest, no land in sight, and all sail set in fine, clear weather. At 7<sup>h</sup> 10<sup>m</sup> r. M., ship's time, another light shock was felt, of about 15 seconds duration; and from 8 to 12 midnight two more very light shocks were felt, but the time was not noted. The captain states that he had experienced

an earthquake at sea on a former occasion, but the one felt before was nothing compared to this one, either in force or duration. (Hydrographic Bureau.)

The bark *St. James*, Capt. 3<sup>d</sup>. O. Parker, while in lat. 26° 19' N., long. 110° 25' W., in the Gulf of California, on August 26, 1906, was shaken by a seaquake at 12<sup>h</sup> 15<sup>m</sup> p. M. The shock lasted a minute, and the sensation was as if the vessel were striking upon sunken rocks. Upon arrival at Guaymas, the captain learned that no shock had been experienced at or about the time noted. (*San Francisco Chronicle*, Sept. 16, 1906.)

The bark *Agate*, Capt. C. H. McLeod, while off the northwest coast in lat. 43° 10' N., long. 128° 50' W., 100 miles west of Coos Bay, experienced a heavy shock on September 2, 1906, at 3<sup>h</sup> 45<sup>m</sup> A. M. The shock lasted nearly 1 minute. The sensation was as if the vessel had struck a coral reef or rock. The wind was light, the weather clear, and the sea smooth. At 3<sup>k</sup> 55<sup>m</sup> A. M., another shock was felt, not so severe nor so prolonged as the first. (*San Francisco Chronicle*, Oct. 2 and 9, 1906. Hydrographic Bureau.)

The ship *Robert Searles*, Capt. J. H. Piltz, while in lat. 41° 78' N., long. 125° 52' W., 85 miles northwest of Cape Mendocino, experienced a severe shock on September 14, 1906, which occasioned a panic among the crew. The cargo (lumber) and upper works of the vessel were shaken. The shock lasted 25 seconds. (*San Francisco Chronicle*, Sept. 17, 1906. Hydrographic Bureau.)

The American schooner *Stanley*, Capt. K. Petersen, while in the calm center of a cyclone, in lat. 46° 09' N., long. 125° 22' W., 55 miles west of Cape Disappointment, on November 6, 1906, felt a sharp shock that lasted 2 or 3 seconds. Immediately afterwards, when looking toward the southwest, the captain saw 3 mountainous waves coming; when they struck, the ship began to pitch and roll violently, and he thought every minute she would be swamped. (Hydrographic Bureau.)

The schooner *Melrose*, Capt. M. McCarron, while in lat. 37° 35' N., long. 123° 35' W., felt a seaquake on February 3, 1907. The first shock was at 10<sup>h</sup> 30<sup>m</sup> A.M., lasting about 8 seconds; and the second at 10<sup>h</sup> 50<sup>m</sup> A.M., lasting about 5 seconds. Neither shock was violent, but each caused a decided trembling of the vessel. The motion was from east to west. The sky was overcast and the sea was smooth, with light westerly winds. The position of the vessel was 28 geographical miles S. 73° W. from the Southeast Farallon. The nearest sounding on the chart is 5 miles north of this position, where there is shown 1,726 fathoms of water.

## NUMBER OF MAXIMA IN THE MAIN SHOCK,

In response to various circulars sent out by the Commission, and to direct inquiries by the members of the Commission or their aides in the field, 154 replies have been received, which constitute testimony as to whether the main shock comprized one or more maxima. Many of these replies are rather questionable scientific evidence, inasmuch as many of them were in response to a leading and suggestive question, and very few of them have been subjected to the clarifying process of cross-examination. So few people were awake at the time the shock began that but a small proportion of the replies come from people who were in full possession of their observational faculties at the beginning of the disturbance; and of those who were suddenly and rudely awakened, few were sufficiently alert for deliberate perception at the time and had to rely upon a somewhat confused memory for the character of the shock. Yet the testimony is of value, and indicates a very general consensus of the impression that there were 2 principal maxima in the shock; and the failure of many to recognize or remember 2 parts to the shock does not seriously invalidate the testimony of those who received that impression.

Of the 154 replies received, 98 testify to 2 maxima; 46 to but one maximum; 9 to 3 or more maxima; and 1 to more than one. Of the 98 who reported 2 maxima, 67 discriminated between the 2 parts of the shock, as to their relative intensity; and of these 67, there were 48 who had the impression that the second maximum was the more severe, and 19 who thought it the less severe. Of the 46 who recognized only one maximum, 32 were beyond the zone of destructive effects, where the intensity was VI or less (in a few cases VII); and of the remaining 14 cases within the zone of destructive effects, 11 were offset or contradicted by other reporters in the same general district as themselves, who record two maxima. It would thus appear that within the zone of destructive effects, say out to isoseismal VII, the evidence, such as it is, points unmistakably to the occurrence of 2 maxima; and the prevailing opinion is that the second was the stronger. The failure on the part of many reporters to discriminate 2 parts of the shock beyond the isoseismal VII is not surprising, and is offset by the considerable number of reports in which 2 maxima were noticed.

*List of observations as to the number of maxima in the earthquake shock.*

Locality.	Reporter.	No. of Maxima.	Remarks.
Nolton .....	Clara Ward.....	2	Second stronger.
Crescent City.....	G. Sartwell.....	2	Interval about 2 seconds.
Montague.....	C. H. Chambers ..	1	Duration 30 seconds.
Upton.....	G. K. Dixon.....	1	
Big Bar.....	W. A. Pattison...	2	A tremor which eased up, then another stronger.
Papoose.....	C. S. Lakemore...	1	
Eureka.....	A. H. Bell.....	1	Maximum intensity toward end; duration 47s.
Fortuna.....	J. L. Thomberry..	2	One greater than the other.
Peppenvood.....	J. F. Helms.....	2	Second stronger.
Brieland.....	J. W. Bowden.....	2	Second stronger.
Fort Bragg.....	E. Higgins.....	2	Continuous shock, 40 s., ending with eavy one.
(Jcn Bkiir.....	A. P. Scott.....	1	
Albion.....	J. Covie.....	1	
Pliilo.....	J. L. Prather.....	2	About the same intensity.
Fi-h Kock.....	J. L. McII.....	2	Second stronger.
Annapolis.....	G. V. Fiscus.....	2	First in wave motion; second rotatory.
Fort Koss.....	O. W. Call.....	Several	Increased in force up to third or fourth.
Cazadero.....	E. H. L. Cowlev..	2	Second stronger.
Hemlock.....	C. J. L. Bowen...	2	Second stronger.
Cloverdale.....	M. C. Bale.....	Several	Oscillatory, ending with series of shocks.
Lakeport.....	J. Overholser.....	1	
Sanhedrin.....	V. L. Fra?4er.....	1	
Oathill.....	J. J. Hulter.....	2	Second stronger.
St. Helena.....	F. Blachow.-ki....	2	Second stronger.
Veteran's Home ..	A. Bruwn.....	1	
Wooden Valley ...	H. W. Chapman..	2	
Cotati.....*	C. L. Jeffrey.....	1	First stronger.

## List of observations as to the number of maxima in the earthquake shock—Continued.

Locality.	Reporter.	No. of Maxima.	Remarks.
Vallejo . . . . .	J. J. Lindunger	2	Increase in severity in latter half.
Tamalpais . . . . .	W. W. Thomas	2	If any difference, first stronger.
San Rafael . . . . .	L. Reubold	2	First light and long, second hard and short.
do . . . . .	E. Landon	1	
do . . . . .	A. Scott	2	First light, second heavier.
do . . . . .	G. L. Richardson	2	First heavier.
do . . . . .	F. M. Watson	2	First lighter and longer than second.
do . . . . .	J. D. Bennett	2	First heavier.
San Mateo . . . . .	B. A. Peckham	3	First and second were heavy wavy motions; third was short rapid trembling.
do . . . . .	R. Anderson	2	Two main thrusts or sets of movements.
Mountain View . . . . .	A. M. Free	2	Second stronger.
Woodside . . . . .	H. O. Beaty	2	Personally observed but 1; others observed 2 or 3 and there is a general agreement that second was stronger.
San Jose . . . . .	J. C. Hartzell	2	Second more intense.
do . . . . .	M. Connell	1	Came suddenly, explosion-like, then a violent swaying.
Santa Clara . . . . .	J. S. Ricard	2	Two shocks, then finally a twist and an uplift.
Campbell . . . . .	F. M. Richter	2	Second stronger.
Los Gatos . . . . .	F. H. McCullogh	1	Wife noticed a preliminary shaking.
do . . . . .	I. H. Snyder	2	Partial intermission of 1 or 2 s. Second much stronger.
do . . . . .	W. S. T. Smith	2	Interval was not sufficient to allow moving objects to come to rest.
Skyland . . . . .	T. Wightman	1	
New Almaden . . . . .	J. F. Tathan	2	Second stronger.
Wright . . . . .	Mrs. A. L. Sears	1	Followed by tremors.
do . . . . .	Flora E. Beecher	2	About equal.
Gilroy . . . . .	W. J. Lawler	2	Second stronger.
Sargent . . . . .	W. B. Stuart	2	First stronger.
Hollister . . . . .	J. N. Thompson	2	Almost continuous; second did most damage.
Tres Pinos . . . . .	G. A. Waring	2	
Paicenes . . . . .	do	1	
(4 miles SW.)			
Bear Valley . . . . .	do	3	Noted by several people.
Bitterwater . . . . .	C. Z. Smith	2	Second stronger.
Hernandez . . . . .	E. M. Tucker	2	First part gentle, second more severe.
Mt. Hamilton . . . . .	H. K. Palmer	2	First harder; memory uncertain.
do . . . . .	A. M. Hobe	2	Jar, then pause, then tremble.
do . . . . .	W. W. Campbell	2	First harder.
Calaveras Valley . . . . .	R. Ingleson	2	2 separate shocks.
Livermore . . . . .	E. G. Still	2	
Danville . . . . .	A. E. Clark	2	Second stronger.
Mt. Eden . . . . .	W. Gaily	2	First sideways, second upward.
Mills College . . . . .	J. Keep	1	
Berkeley . . . . .	A. C. Lawson	2	First prolonged, with secondary maxima; second brought down chimneys and ended rather abruptly.
Bolinas . . . . .	J. G. Peter	2	Second stronger.
Farallones . . . . .	J. A. Boyle	2	First stronger.
Santa Cruz Range . . . . .	M. Doyle	2	Tremor, then distinct shock; then violent shock, then tremor.
Bellvale . . . . .	Lilla E. Bell	2	Continuous shake with 2 heavy parts.
Santa Cruz . . . . .	G. A. Waring	2	Second stronger.
do . . . . .	O. J. Lincoln	2	
Delmas } . . . . .			
Seabright } . . . . .	G. A. Waring	2	Shook came suddenly, diminished, then at a second jolt the chimneys fell.
Twin Lakes } . . . . .			
Bonnie Doon . . . . .	T. IL Thayer	2	Second stronger.
Soquel . . . . .	Matilda Baker	2	First stronger.
Ben Lomond . . . . .	I. R. Guichard	2	Second stronger.
Watson villo . . . . .	E. McCabt*	1	
Castro ville . . . . .	G. A. Waring	1	Felt as 1 continuous vibration.
Prunedale . . . . .	II. H. McIntyre	2	Second stronger.
Salinas . . . . .	Bertha M. Abbott	2	Si'niul stronger.
Monterey . . . . .	N. W. James	2	First stronger.
Chualar . . . . .	G. P. Anderson	2	
Ixmonk . . . . .	J. RLst	1	Continuous shock, light at first; finishing with a hard stn.»kt' and twist.
Shandon . . . . .	(J. J. Shaw	2	

## List of observations as to the number of maxima in the earthquake shock — Continued.

Locality.	Reporter.	No. of Maxima.	Remarks.
San Luis Obispo...	S. D. Ballou . . . . .	1	
do . . . . .	J. R. Williams . . . . .	1	50 seconds long.
do . . . . .	M. R. Venable . . . . .	2	Slight tremor; then a second more severe; then a distinct oscillation, quite hard; then a tremor.
Santa Maria . . . . .	F. R. Schanck . . . . .	3	First and second, 1 or 2 s.; third, 12 to 15 s.
Pismo . . . . .	Emma M. Patchett . . . . .	2	Second stronger.
Lorapoc . . . . .	A. McLean . . . . .	1	One long shock.
do . . . . .	C. K. Studley . . . . .	2	First gradually increased to maximum and gradually decreased. Second died suddenly.
Santa Barbara—	J. A. Dodge . . . . .	1	About a minute long.
do . . . . .	S. F. Hunt . . . . .	3	Second strongest.
Los Angeles . . . . .	W. D. Fuller . . . . .	1	
Compton . . . . .	L. A. Rockwell . . . . .	2	First stronger.
Azusa . . . . .	A. P. Griffith . . . . .	1	As if house had been struck by heavy blow.
Toluca . . . . .	W. C. Meddington . . . . .	2	
Redding . . . . .	L. F. Bassett . . . . .	1	
Colusa . . . . .	F. Roche . . . . .	More than 1	Shock would die out, only to return again.
Meridian . . . . .	T. J. Taylor . . . . .	2	Second stronger.
Marysville . . . . .	R. F. Watson . . . . .	2	First lasted about 45 s.; the second about 90.
Rumsey . . . . .	J. M. Morrin . . . . .	2	Second stronger.
Guinda . . . . .	J. Jacobsen . . . . .	1	Continuous shake.
Capay . . . . .	S. Schwale . . . . .	1	Continuous shake.
Woodland . . . . .	I. A. Morris . . . . .	2	First stronger.
Plainfield . . . . .	H. O. Purington . . . . .	2	First stronger.
Black's Station . . . . .	S. P. Cutler . . . . .	2	First stronger.
Knight's Landing . . . . .	L. T. Shamp . . . . .	2	First stronger.
Sacramento . . . . .	J. A. Marshal . . . . .	2	Oscillation ended in 2 jars, with appreciable time between.
Fairoaks . . . . .	L. M. Shelton . . . . .	1	One straight shakej very light.
Main Prairie . . . . .	Mrs. A. Rattike . . . . .	1	
Binghamton . . . . .	W. H. Smith . . . . .	2	Second stronger.
Collinsville . . . . .	J. Antonini . . . . .	4	Second stronger.
Ione . . . . .	J. F. Scott . . . . .	2	Second stronger.
Stockton . . . . .	E. P. Higby . . . . .	2	Of equal strength; interval of a few seconds.
Oakdale . . . . .	E. C. Crawford . . . . .	3	Second stronger.
Turlock . . . . .	J. L. Brown . . . . .	1	
Westley . . . . .	W. G. Carey . . . . .	2	Second stronger.
Merced . . . . .	F. J. Reidy . . . . .	2	Second stronger.
Madera . . . . .	F. E. Smith . . . . .	2	30 s. and 60 s.; second stronger.
Fresno . . . . .	J. P. Bolton . . . . .	2	First stronger.
Jameson . . . . .	W. J. Williams . . . . .	2	
Kingsbury . . . . .	A. B. Loomis . . . . .	1	
Riverdale . . . . .	W. Lenson . . . . .	2	Second stronger.
Visalia . . . . .	A. M. Doty . . . . .	4	Last most pronounced.
Exter . . . . .	H. R. Stephens . . . . .	2	Nearly equal in intensity.
Bakersfield . . . . .	A. G. Grant . . . . .	1	10 seconds.
MeArthur . . . . .	J. MeArthur . . . . .	2	First stronger.
Susanville . . . . .	J. Branham . . . . .	1	Probably 2 s-
Quincy . . . . .	L. A. Barrett . . . . .	1	
Kittle . . . . .	F. Campbell . . . . .	1	
Beckwith . . . . .	J. W. Middletoa . . . . .	2	Not sure; there was a wavelike motion, with a sudden jar at the end.
Boca . . . . .	A. E. Daswell . . . . .	1	60 s.
Stirling City . . . . .	H. B. Weaver . . . . .	1	
Paradise . . . . .	F. W. Day . . . . .	2	Second stronger.
Allegheny . . . . .	W. A. Clayton . . . . .	2	
Pino Grande . . . . .	W. E. Ba.sham . . . . .	1	
Nashville . . . . .	J. C. Hcald . . . . .	1	
West Point . . . . .	J. A. Wilson . . . . .	1	
Railroad Flat . . . . .	E. Taylor . . . . .	1	
Milton . . . . .	J. H. Southwick . . . . .	2	Second stronger.
Tuolumne . . . . .	J. T. Thompson . . . . .	2	
do . . . . .	J. E. Coover . . . . .	1	
LaGrange . . . . .	J. A. Hammond . . . . .	2	Second stronger.
Sequoia . . . . .	M. Crocker . . . . .	2	2 proJott^ed light sbocks.
Darrah . . . . .	R. Darrah . . . . .	2	Second stronger.
Fresno Flats . . . . .	Postmaster . . . . .	1	
Gold . . . . .	T. J. Rhodes . . . . .	2	Both about <i>the</i> same; quite heavy.
Magnet . . . . .	?	1	
Mono Lake . . . . .	E. A. Bvnediet . . . . .	2	First stronger.
Law3 . . . . .	G. D. Louderb&ek . . . . .	2	First gentle rocking; jsecond small jerks.
Lone Pine . . . . .	do . . . . .	2	A few seconds apart.
do . . . . .	G. F. Marsh . . . . .	2	First stronger.

## SOUNDS CONNECTED WITH THE EARTHQUAKE.

An interesting manifestation of the earthquake was the sound which was heard by many people in connection with the shock. Appended is a tabulated statement of the testimony bearing upon this phenomenon, if it may be so called. In this tabulation there are recorded 81 observations of people who heard sounds, without segregating those which are reported in a summary way as the common experience of "some," "several," or "many" persons. Of those, 40 report having heard sounds before having felt the shock; 14 report the sound as accompanying the shock or coincident with it; 3 heard a sound after the shock; and 19 report having heard unusual sounds at the time of the earthquake, without further specification. Besides this, there are 3 reports of sounds having preceded after-shocks, one case where the sound was observed to precede the second phase of the shock but not the first, and one case where sound was heard but no shock was felt. The observations are fairly well distributed over the region affected by the shock. Besides these observations of a positive kind, there were many cases reported where no sound was heard, altho the people were awake.

In view of the 40 positive and independent observations of sounds having preceded the shock, with, in some instances, specific evidence of actions induced by the sound having been engaged in during the interval between first hearing the sound and feeling the shock, there can be little question that sound vibrations of the air actually preceded the sensible shock. The testimony of the 14 persons who heard the sound during the shock does not contravene that of the 40 who heard it before, nor does that of the 19 persons who do not particularly specify the time relation of the sound to the shock. Sounds heard before the shock may well have continued thru the shock and come to the attention of less alert people only when the shock was felt. The three observations of sounds preceding the after-shocks are corroborative of the 40 referring to the main shock. The one case near Alturas, where men in camp heard a sound but felt no shock, is an interesting and exceptional, but credible, one.

The evidence as to the character of the sounds is consistent and uniform. They were vibrations low in the scale. This fact suggests an explanation of the failure of certain people to hear the sounds when others in the same vicinity observed them. It may be that the vibrations in question are below the range of audibility of some people and within that of others. With this question in mind, an inquiry was addressed to Prof. G. M. Stratton of Johns Hopkins University, in regard to the limit of sound. His reply was as follows:

The lowest limit of sound is so differently given by different investigators that it seems clear that individual differences play an important part. The limit is placed all the way from 8 to 30 double vibrations a second, and that may represent the range of personal variation; but more probably it varies between 16 and 30; and those who think they hear as low as 8 are in reality hearing the second partial of that tone, viz., 10 d.v. This, of course, applies only to the perception of tone; for of repeated shocks at a very low rate we can still hear the separate shocks, *e.g.*, puffs or blows, but they do not as yet fuse into a continuous tone.

Now if it should be a fact that the rumbling sounds which preceded the shock fall within the range of from 16 to 30 double vibrations per second, then from the probability set forth by Professor Stratton, the auditory organs of some people would be sensitive to such vibrations, while those of others would not.

<sup>1</sup> Professor Stratton refers to a chapter on "Tiefen! Tiefste. Tiefe," in Helmholtz's *Lehre von der Tonempfindungen*, where the difficulties of accurate determination and the different things that appear in such tones are well set forth.



Another interesting question to which the testimony gives rise is: How do such vibrations reach any locality in advance of the shock? The seismic waves traverse the earth's crust very much more swiftly than sound-waves do the air, so that it is a physical impossibility for sound-waves generated in the air above the seat of disturbance to outreach them. The vibrations observed as sounds must, therefore, be transmitted to the atmosphere by tremors of the ground which precede the larger waves, and which are not otherwise perceptible to the senses ordinarily. These doubtless correspond to those phases of seismic movements which are recorded by delicate instruments and are known as "preliminary tremors."

*Noises heard at the time of the shock.*

Locality.	Reporter.	Observer.	Kind, direction, time of noise, etc.
Ferndale.....	A. W. Blackburn	Same.....	Accompanying the quake was a rumbling, roaring sound.
Covelo.....	E. S. Larsen	Large proportion of residents	Roar just preceding earthquake shock.
Fort Bragg.....	O. F. Barth	A man.....	The wave traveled SW. and a roar accompanied it.
Mendocino.....	Wm. Mullen	Same.....	Unusual rumbling sound like distant thunder, preceding shake, being loudest at commencement of disturbance.
Albion.....	J. Coyle	Same.....	Roaring noise like heavy fall of hail coming from ocean to the west.
Point Arena.....	W. W. Fairbanks	Not named.....	Heavy roaring sound preceded the shock.
Point Arena Light-house.....	do.....	Keeper.....	Blow came quick and heavy, accompanied by heavy report.
Upper Lake.....	C. M. Hammond	do.....	A roaring noise past off to SW.
do.....	do.....	Workmen.....	A noise in the trees as tho heavy wind were blowing thru them; then the rumbling past off to SW.
Cloverdale.....	M. C. Bale	Many persons	Rumblings before the shock.
Healdsburg.....	H. R. Ball	Same.....	Attended by great rumbling noise, as thunder.
Santa Rosa.....	Miss F. Locke..	R. Worthington..	Heard roaring.
do.....	do.....	Mr. Campbell	Heard a great roaring 2 s. or 3 s. before the shock.
do.....	do.....	Watchman.....	Heard noise in SW.; then felt breeze; then felt shock.
do.....	do.....	Mrs. Lloyd.....	Heard noise; ran to window and opened it; then shock came.
do.....	do.....	A man.....	Heard roaring and saw wave of earth 2 feet high.
Cotati.....	C. L. Jeffrey	Same.....	Sound as of a strong wind before shock.
Tomales.....	do.....	A boy.....	Heard roaring and said, "Oh, there's thunder," before the shock.
do.....	do.....	A farmer.....	Heard roar from SW.
do.....	do.....	Mr. Goudy.....	Heard a great roaring sound from SE.
Point Reyes Station.....	do.....	A farmer.....	Heard roar, then felt wind on my face.
Olema.....	do.....	A dairyman.....	Heard noise in the ground, got up, then felt shock.
Bolinas.....	K. Easton.....	Same.....	Rumbling noise preceded one after-shock on April 18,
Calistoga.....	Dan Patten.....	Same.....	A rushing noise before shock came.
Napa.....	T. Hull.....	Not named.....	A rumbling, then came yhock.
Alturas.....	C. B. Towle.....	Sonic men in camp	Heard low sound of earthquake, but did not feel shock.
Redding.....	L. F. Basset.....	Same.....	Noise resembled a passing train; it preceded and outlasted the shock.
Chico.....	E. Mayhew.....	Same.....	Rumbling sound thruout the disturbance like heavy-laden wagon passing house.
Willows.....	A. W. Sehorn.....	Same.....	Unusual rumbling sound preceded shock, gradually grew louder, and died away with the shaking.
Colusa.....	Fred Roche.....	Same.....	Sound like an approaching train coincided with shock.
Berkeley.....	Miss F. Locke...	Capt. Fire Dept...	Was awakened by roar 5 s. before shock.
San Franriseo...	M. C. Erskine...	Same.....	Awake at 5 <sup>h</sup> 10 <sup>m</sup> A.M. Heard a great roaring from NE.; soon the shock came from same direction.

*Noises heard at the time of the shock. — Continued.*

Locality.	Reporter.	Observer.	Kind, direction, time of noise, etc.
San Francisco	T. J. J. See . . . . .	Lieut. Bertholf and other officers	A low rumbling preceded earthquake.
Peninsula of San Francisco . . . . .	R. Anderson	Many persons	Noise accompanying the shock; indescribable noise associated with main shock; immediately after the shock.
San Mateo . . . . .	B. A. Peckham..	Mr. Maxwell. . . . .	Heavy rumbling which he took for thunder, from NW., before shock.
San Jose . . . . .	Mr. Connell . . . . .	Same. . . . .	An undertone, rumbling sound coincided with beginning of shock.
do. . . . .	W. S. Prosser . . . . .	Several good observers outdoors	The noise of the quake came from SE. and died away toward San Francisco.
Santa Clara . . . . . (3 mi. west)	I. H. Snyder....	D. Pickering . . . . .	Sound compared to stampede of cattle.
Congress Springs	J. C. Branner....	Residents. . . . .	Shock accompanied by rumbling; after-shocks preceded by sound like a blast.
Los Gatos . . . . .	L. H. Snyder	Mr. Land. . . . .	Premonitory roar came from south.
do. . . . .	W. S. T. Smith..	Same. . . . .	No sound heard for main shock, but muffled sound heard just before each minor shock.
do. . . . .	F. H. McCullogh	Same. . . . .	Sound as of bad storm coincident with first and worst of shock. Later in the day there was a rumbling sound to me (deaf) not unlike a distant detonation.
Wright, 4 miles south of . . . . .	L. E. Davidson..	Same. . . . .	Attention first drawn to a slight rumbling noise.
Glenwood . . . . .	Miss F. Locke...	Different persons	After every shock on April 18 was a rumble like that of artillery.
Scott Valley (Santa Cruz County)	do. . . . .	Mrs. Field . . . . .	Tremendous roaring in NE.
Santa Cruz . . . . .	G. A. Waring	Wharfinger . . . . .	Rumble before shock.
Santa Cruz Light-house . . . . .	do. . . . .	Keeper	Noise as of a wagon crossing a bridge preceded every quake.
Wilder's Dairy N. W. of Santa Cruz . . . . .	do. . . . .	Not named . . . . .	Shock preceded by rumbling from south.
Swanton . . . . .	do. . . . .	do. . . . .	Distinct noise as of team crossing a bridge to NW. preceded every shock.
Ano Nuevo Light-house . . . . .	do. . . . .	Keeper	Distinct rumbling preceded shock.
Pescadero . . . . .	do. . . . .	Some people....	Noise as of wind preceded the shock.
Castroville . . . . .	do. . . . .	Not named . . . . .	Shock described as beginning like a, subterranean blast.
Salinas . . . . .	Bertha M. Abbott	Same. . . . .	Rumbling noise coincided with shock.
San Lucas	G. A. Waring	Not named . . . . .	Sound reported to have been heard.
Fort Romie . . . . .	do. . . . .	Not named . . . . .	Noise heard after shock.
San Luis Obispo, 1 mile east of..	do. . . . .	do. . . . .	Great roar heard.
New Almaden (Hacienda) . . . . .	do. . . . .	Not named . . . . .	Loud noise like thunder traveled northward, distinctly preceding shock.
Coyote . . . . .	do. . . . .	A man. . . . .	Noise from SE. seemed to pass over him.
San Martin . . . . .	do. . . . .	A man . . . . .	Heard roar, horse became frightened before shock came.
Gilroy to Hollister	do. . . . .	Various persons..	Rumble heard all thru region from Old Gilroy and San Filipe to Hollister. One said from SE., another from SW.
Tres Pinos . . . . .	do. . . . .	Not named . . . . .	Distinct rumble preceded shock at Palm-tag's winery.
Bell's Station	G. F. Zofftnan...	do. . . . .	Rumble distinctly heard before the shock.
Paicnes . . . . .	G. A. Waring	do. . . . .	Distinct noise preceded shock at Cienega Lime Kilns.
Hernandez . . . . .	do. . . . .	do. . . . .	No noise before quake, but report as of blast immediately preceded second (hardest) period of vibration.
Mt. Hamilton . . . . .	K. Burns.....	Same. . . . .	Sound as of flight of birds simultaneous with shock.
Calaveras Valley	G. F. Zoffnuin..	R. Ingleson.....	The two separate shocks accompanied by roaring sound from north.
Modesto . . . . .	E. Hughes . . . . .	Several persons . . . . .	Roaring or rumbling sound beginning & few seconds before and continuing until end of disturbance.
do. . . . .	do. . . . .	(Green Bros. . . . .	Roaring sound just before shock.
do. . . . .	do. . . . .	Mr. Elsey. . . . .	Rumbling sound.

*Noises heard at the time of the shock—Continued.*

Locality.	Reporter.	Observer.	Kind, direction, time of noise, etc.
Modesto . . . . .	E. Hughes ..	A. H. Holtman ..	Shock preceded by roaring sound.
do . . . . .	do . . . . .	H. Hintze . . . . .	Rumbling sound.
Stockton . . . . .	do . . . . .	Some persons out of doors . . . . .	Dull rumbling sound just preceding shock; some think it emanated from buildings.
Westley . . . . .	W. G. Carey	Men sleeping on scow on river..	Heard terrible rumbling 30 s. before shock; came out of scow to see what it was, then shock came.
Conejo . . . . .	E. Picket__	Same . . . . .	Awakened by noise like locomotive coming at full speed.
Santa Barbara	J. A. Dodge.	Neighbors . . . . .	Rumbling just before shock.
Lone Pine, Ne- vada . . . . .	G. F. Marsh.	Same . . . . .	Slight rumbling sound like wind blowing.
Ballarat, Inj <sup>o</sup> County . . . . .	D. C. Pickett	Same . . . . .	Awake and up. First indication of earthquake was low, distant, and increasing roar.

## VISIBLE UNDULATIONS OF THE GROUND.

The earth-waves generated at the fault past thru the earth's crust with a velocity of probably from 2 to 3 kilometers per second. The undulations of the surface due to the passage of such waves would be so swift that they would scarcely be observed visually. Yet there is considerable testimony, of a consistent and independent character, that much slower undulations were observed. This testimony comes from various parts of the region disturbed, and a great deal of it is positive and unequivocal as to what seemed to be the fact. The evidence indicates that there is a type of wave in the ground, in the region of high intensity, which has not yet been sufficiently recognized, and the origin of which is obscure. Some 20 or more observations bearing upon this class of phenomena are here summarily recorded:

Judging from the descriptions given, these waves behaved like undulations in water, with an oscillation approximately normal to the surface. They were for the most part observed on alluvial tracts, but some of the reports come from districts where there is but a thin veneer of alluvium or soil upon the rocks. If it should prove, on the basis of more abundant evidence, that these waves are peculiar to alluviated basins, they may be explained as reflections from the rocky slopes of such basins. If a bowl of liquid be tapt smartly, vibrations are inaugurated in the rigid bowl which have a speed so great that the secondary waves generated in the liquid pass out from all parts of the walls of the vessel sensibly at the same instant. But the secondary waves thus generated in the liquid have so slow a rate of propagation that they are quite apparent to the eye, and in the central part of the surface of the liquid, when the waves meet, there is a violent commotion. If, instead of a bowl of liquid, we have a rock basin filled with water-saturated alluvium, it seems probable that a similar effect would be produced in a modified degree; and the visible waves at the surface may have had such an origin. But whatever be their origin, it is apparent that they must be a large factor in damaging structures situated upon the ground in which they occur, and so raising the apparent intensity on any scale based on destructive! effects.

*Freshwater, Humboldt County* (S. E. Shinn).—My orchard raised up between 2 and 3 feet like a big breaker coming in.

*Ferndale, Humboldt County* (A. W. Blackburn).—Those who claim to have been out of doors when the shock came, state that the earth rose and fell like the waves of the sea.

*Fort Bragg, Myndocino County* (O. F. Bartli).—A man walking along the street was thrown down. He is positive the wave traveled southwest. The ground undulations wore 2 and 3 feet high.

*Point Arena, Mendocino County* (W.W.Fairbanks).—The ground moved in undulating swells or waves, rising and falling.

*Santa Rosa, Sonoma County* (Miss Locke). — A man saw an earth-wave 2 feet high.  
*Cotati, Sonoma County* (C. L. Jeffrey). — The surface of the earth waved like water.

*Napa, Napa County* (T. Hull). — Those who were out of doors say the trees bent as the shock came like a wave of the ocean.

*Pleasanton, Alameda County* (Miss F. Locke). — A lady near Pleasanton saw the earth go in waves like the ocean.

*San Francisco* (Miss F. Locke). — A fireman at the engine house 1757 Waller Street said the ground went in waves.

*San Mateo, San Mateo County* (Mr. Maxwell). — The earth rose and fell like the swell of the sea, the swells being about 3 feet high.

*Saratoga, Santa Clara County* (Louise M. Atkinson). — Distinct waves past over the ground from northwest to southeast, the orchard trees rising and falling on each wave, like ships at sea, while the electric poles along the road leaned this way and that, some seeming almost to touch the ground.

*Santa Clara, Santa Clara County* (I. H. Snyder). — Mr. Dan Pickering, living a mile south of Santa Clara, says that the ground rose and fell in waves about a foot high. Others say that the orchards seemed to be agitated by a wave-like motion.

*San Jose, Santa Clara County* (W. S. Prosser). — Many persons saw waves in the ground. Sifting out exaggerations, these appeared to be rather more than a foot in height. The best observer estimated the distance from crest to crest, at 60 feet; others much less, but they must have been greater, for there is no evidence which shows any such vertical cracks as would have been produced by short waves. A good observer 6 miles southwest of San Jose described the waves as parallel with certain tree rows which are northeast and southwest; and the waves moved from him at right angles to the line toward San Francisco. Another person, 6 miles northwest from San Jose and looking south, saw the waves (which he thinks were east and west) coming toward him, and hence toward San Francisco; but about the middle of the quake these were met by other waves and the whole surface resembled hillocks or cross seas, and the tree-tops waved wildly. To the man to the southwest of San Jose, however, the tops of the trees were almost still, while the trunks waved sinuously.

*Meridian, Santa Clara County* (G. A. Waring). — A lady reports seeing waves traveling southward along the driveway, and a man reports seeing a heavy wagon move back and forth several times, 4 or 5 feet along the driveway.

*Campbell, Santa Clara County* (F. M. Righter). — People out of doors at the time state that there was a very rapid wave-like motion of the surface of the earth.

*Wright, Santa Clara County* (Flora E. Beecher). — Mr. Deacon, our neighbor, rose and stood by the window, and he declares that the ground rose in waves.

*Coyote, Santa Clara Comity* (G. A. Waring). — Near Coyote a man reports having seen a northwest-southeast fence move in a wave-like motion, beginning at southern end.

*Paicenes, San Benito County* (G. A. Waring). — Toward the Cienega Lime Kilns, 4 miles south of Paicenes, a man reports seeing a wave coming westward thru a grain field.

*San Lucas, Monterey County* (G. A. Waring). — West of San Lucas the waves were reported to have been seen moving southward over the hills.

*San Luis Runrh, near Paeheco Pass* (G. F. Zoffman). — Mr. Mills stated that the surface of the ground moved up and down like the waves of the ocean.

*Mendota, Fresno County* (G. F. Zoffman). — The\* people who observed the plains at Mendota said that they assumed a wave-like appearance, and that the trains rose and fell as the undulations past beneath the tracks. They also stated that this wave-like appearance was confined to the north and south movement,, the east and west motion being more in the nature of a tremor.

*Visalia, Tulanc County* (F. A. Swanger). — The movement of swell and fall of wave seemed strong.

## PATHOGENIC EFFECTS OF THE EARTHQUAKE.

A curious and fortunately trivial effect of the earthquake was the production of nausea. This was observed especially in the region of slower motion of the earth, beyond the zone of destructive effects, but one or two cases being reported from the region of high intensity. The sickness produced was in most cases apparently similar to seasickness, and ascribable to the swaying of the ground. In the few cases which occurred in the region of quick motion, the nausea was more probably due to nervous shock. Brief mention is here made of the cases reported, tho there were probably many others.

At Ruby, in Siskiyou County (R. E. Madden), intensity III—II, persons were slightly nauseated or rendered dizzy, but the feeling past instantly. At Upton, Siskiyou County (E. R. Dixon), intensity IV-III, people felt seasick. Mr. J. H. Roberts, of Yuba City, intensity VI-V, reports that 5 persons on his place were made quite sick. In Marysville (R. F. Watson) the shock caused a dizzy feeling. At Stockton (E. Hughes), intensity VI, a considerable number of people suffered from nausea and dizziness, with headache, for a time after the shock. With some these disagreeable symptoms persisted all the following day. At Modesto (E. Hughes), intensity VI, a number of people were affected by symptoms somewhat like those of seasickness for several hours after the shock. San Francisco (Miss F. Locke). Mrs. E. was nauseated by the earthquake and felt pains in her heart. Several people were nauseated by the motion of the ground at Pescadero, San Mateo County, intensity VIII-VII. (G. A. Waring.)

In Bear Valley, San Benito County (G. A. Waring), intensity VI-V, a man out-of-doors became dizzy and nauseated, but did not at the time realize the cause. Thru the south end of the valley several people became dizzy. Between Mendota and Coalinga (G. F. Zoffman), intensity VII-VI, many persons suffered from a nauseating sensation. At Conejo, Fresno County (E. Pickett), intensity VI, the earthquake made some people sick at the stomach. At Santa Barbara (J. A. Dodge), intensity III, a woman who was out-of-doors at the time of the shock was made slightly dizzy. In Gardnerville, Nevada (J. A. Reid), intensity IV, a number of people complained of a feeling of nausea while eating breakfast at the time of the earthquake, but they felt no motion. At Yerington, Nevada (G. D. Louderback), intensity IV-III, one person experienced a dizzy sensation. At Lone Pine, Nevada (M. S. Dearborn), intensity IV, a good many people when they first felt the shock thought that they were simply dizzy.

## EFFECT OF THE EARTHQUAKE ON ANIMALS.

Miss Mnette Locke, of Santa Cruz, has interested herself in an inquiry into the behavior of animals at the time of the earthquake, and has prepared lengthy notes reciting incidents which were reported to her as the effect of the main shock and the after-shocks upon animals in various parts of the Coast Ranges extending from Santa Rosa to Santa Cruz. Her notes, which refer chiefly to domesticated animals, form the basis for the following summary statement:

*Horses.* — Horses whinnied or snorted before the shock and stampeded when the latter was felt, some falling owing to the commotion of the ground. Horses in harness became frightened and ran away, while others stopt and screamed. Some horses with riders in the saddle stumbled and fell; others stood and shivered. A mule near Santa Rosa refused to eat all day. A farmer in the same neighborhood observed his horses moving about, whinnying and snorting, and called to his boy, who was with them, inquiring what was the matter, but before the boy could answer he felt the shock. In a stable of 30 horses on Alabama Street, San Francisco, all reared, snorted and jumped before

the stable-man, who had just fed them, knew the cause of the trouble. Of the 30, all but 5 broke their halters and came toward the stable-man, who had to keep them off with a pitchfork. Several horses at the various engine houses of the San Francisco Fire Department became frightened and broke away from their stalls. In stables generally horses broke away from their stalls, and some failing to break loose lay down.

*Cattle.* — Cattle on the hills came down to lower levels, and in some localities did not return to the hills for some days after the shock. Cows in corrals near the fault-line were in many localities thrown to the ground; others stampeded and ran about wildly. At Olema cows in the milking corral were thrown to the ground and rolled over, and as soon as they could stand they stampeded. The stampeding of cows from the milking corral was reported at many ranches. Several instances were reported where cows stampeded before the shock was felt by the observer. In other cases cows about to be milked are said to have been restless before the shock and to have lain down as soon as the shock was felt, some giving less milk than usual. Two cows near Duncan's Mills are said to have died as a result of the shock. Several cows dropt calves prematurely. Lowing and bellowing of the cattle at the time of the shock was very commonly reported, and in some cases this is said to have occurred a little before the shock.

*Cats.* — Various reports regarding the behavior of cats at the time of the earthquake and the after-shocks indicate that they became alarmed. Some rushed about wildly, with big tails and bristling backs; some hid in dark corners and otherwise behaved abnormally; some disappeared for several days after the shock. In the after-shocks, cats seemed to perceive the tremor before people did, and crouched in fright or ran. At Olema 7 cats were not seen for 2 days after the shock, and in Alameda some cats disappeared for 3 days. Some carried off their kittens.

*Dogs.* — Dogs generally became alert before the after-shocks, and barked, whined, or ran to cover. After the shock some ran away and did not return for a day or several days. Some barked at the time of the shock and ran about with their tails between their legs. Many sought the protection of houses and stayed close to people after the shock. One dog near Santa Rosa ran about the house for 10 seconds before the shock was felt, and then jumped out of an open window down one story to the ground. Some dogs were in an excited condition, running about vaguely for some time after the shock; and this was repeated at the after-shocks. Others ran straight away at full speed. Some bitches brought their puppies to what apparently seemed to them safer quarters. Some took to their beds for several days after the shock and others refused to eat. The most common report regarding the behavior of dogs was their howling during the night preceding the earthquake.

*Chickens.*—Chickens generally ran for shelter to their houses, with their wings outstretched, squawking.

*Wild animals in confinement.* — The wild animals in confinement at the Chutes, San Francisco, crouched and remained quiet during the shock, but roared after it was over, led by the elephant. The elephant also roared at the times of the after-shocks.

## MINOR GEOLOGICAL EFFECTS OF THE EARTHQUAKE.

---

### LANDSLIDES.

There are three types of landslides known in the Coast Ranges. For convenience in reference they may be designated as earth-avalanches, earth-slumps, and earth-flows. The first and last of these are of somewhat exceptional occurrence, but the second is exceedingly common. These landslides are of geological importance to an agency concerned in the evolution of the geomorphy of the Coast Ranges of California to an extent equaled in few other regions; and it becomes a matter of interest to appreciate the rôle played by earthquakes in promoting the efficiency of this agency. The activity of all three kinds of landslides is related directly or indirectly to the earthquake of April 18, 1906. In order to appreciate certain phases of the relationship, it will be of advantage to state briefly, in a general way, some of the characteristics of these different types of landslides. In doing this, reference will first be made to the most commonly occurring type, the earth-slump. The other two may then be characterized by contrast with this type.

Under normal conditions, earth-slumps appear chiefly as features of mature slopes which are in adjustment to the ordinary processes of rain erosion. They are also found, however, as notable features of immature slopes, at the base of which horizontal corrasion is active, as on sea-cliffs and stream-cliffs, supplanting under certain conditions the earth-avalanche which is chiefly found in such situations. On the mature slopes of the Coast Ranges of California, under present climatic conditions, the regolith or mantle of decomposed rock, on the more common rocks, appears to be accumulating at a somewhat faster rate than the rain-wash can remove it. This excessive accumulation of the regolith appears to be an important factor in producing conditions conducive to earth-slumps. The climate of the region is characterized by a pronounced alternation of dry and wet seasons. In the summer the soil and regolith on the hillsides are dried out to a considerable depth, in many cases down to the underlying firm rock; and as the desiccation proceeds the soil shrinks and cracks. The cracks thus formed permit the ready access of the early winter rains to the deeper portions of the soil and regolith. The concentration of the entire rainfall in one half of the year is also more conducive to the saturation of the ground than if it were distributed thruout the year. The climate is thus a contributory factor to the prevalence of earth-slumps.

A factor of local importance is the character of the underlying geological formations. Where these consist of clays or shales, earth-slumps are much more liable to be inaugurated and to recur than where the rocks have little or no clay in them. The emergence of springs on hillsides is also a fruitful cause of earth-slumping where other conditions, particularly the last mentioned, are favorable. Another factor may be the recent subjection of the hill-slopes to grazing and tillage. In general, however, this interference with natural conditions appears to have been conducive to excessive corrasion and sapping, rather than to slumping. Grazing and tillage rob the surface of its natural protection of dead grass and other vegetation, which in the early winter season tend to restrain the rapid flow of the rain-water and its concentration in lines of corrasive activity. New lines of corrasion are thus inaugurated, and where the rocks are but slightly coherent

new geomorphic forms, of the bad-land type, are evolved with startling rapidity. This corrosive process is sometimes complicated by earth-slumping.

The activity of earth-slumping as a degradational process is, in general, a function of the amount of rainfall in any given season. Thus in the winter of 1889-1890, in which the rainfall was exceptionally heavy, earth-slumps thruout the Coast Ranges were much more active than in seasons of normal rainfall, and many new ones were started. In all such earth-slumps the saturation with water of the soil and regolith, and in some cases of the underlying formations, is an essential condition. This water is the main agent in loosening or disintegrating the material preparatory to the slip. It is also a motive power on account of the large addition which it makes to the weight of the unstable mass; and it is a transporting agent owing to the fluid or plastic nature which it imparts to it.

The character of the movement in an earth-slump is noteworthy. The ground moved drops away from the slope in the form of a bite, leaving a lunate or horseshoe-shaped scarp overlooking the sunken area. As the mass moves down, it generally encounters the resistance of more stable portions of the slope below, and is thus crowded upon itself. The plastic mass is in this way deformed, and the deformation amounts in many cases to an effective rotation of the moved portion upon a horizontal axis. The lower portion is thrust over the passive ground at its lower margin, and the slope of the surface of the moved part is greatly diminished and in many cases reversed. Between the reversed slope and the limiting scarp a depression is thus formed which may become a pool. The change in the slope thus occasioned gives rise to the landslide terrace.<sup>1</sup> This kind of movement may be slowly continuous for considerable periods, or it may be fitful, depending upon the supply of water. In a slumping tract the movement may be repeated at various levels, giving the slope an irregularly stepped or terraced profile; and if the movement has been recent, numerous cracks and fissures traverse these terraces, particularly where they break away from the upper limiting scarp.

The instability of the mass is an essential feature of the earth-slump. When not actually moving, its movement is imminent at all times, but with varying degrees of imminence, depending upon local conditions. This instability and imminence of movement is true of many slopes where no actual earth-slump has appeared, but where movement may be inaugurated at any time by an exceptionally heavy winter or by some other precipitating cause. Severe earthquakes constitute one of these precipitatory causes. Thruout the Coast Ranges of California the small residual stability of many earth-slumps was overcome by the vibration of the ground at the time of the earthquake of April 18, and they were caused to slump forward. In many other instances new earth-slumps were started, owing to the same general cause. Besides the earth-slump movements which were the immediate effect of the earthquake shock, there were doubtless others which were indirectly referable to the same cause. As will be shown in another part of this report, one effect of the earthquake was the derangement of the normal movement and amount of flow of underground waters, the general result being a temporary increase of flow. Inasmuch as many earth-slumps depend for their water upon springs, there can be little doubt that the increased flow had its effect upon these, and promoted their activity several days or possibly weeks after the shock itself.

Another way in which the shock conduced to the activity of earth-slumps at a later date than the shock itself was by opening cracks and thus rendering the deeper {Millions of the unstable mass more accessible to the rains of the following winter. The movement of earth-slumps at the time of the earthquake was abnormally large and sudden, thus leading to the development of numerous open cracks, not only in the landslide proper, but also in the surrounding slopes above the limiting scarp. The effect of this

<sup>1</sup>See U. S. G. S. Monograph, I, Lake Bonneville, by G. K. Gilbert, p. 53.



would inevitably be the enlargement of the area of the slide in the wet season. Similarly on many slopes, particularly at points not far distant from the Rift, numerous cracks were opened without actual slumping of the ground occurring in consequence of the shock; but the conditions were thus provided for the slumping process the following winter. During the winter 1906-1907 many such slides were reported in a general way. Unfortunately detailed information as to their occurrence is as yet lacking. It is to be noted that an exceptionally heavy rainfall conspired with the conditions established by the earthquake to produce these landslides.

In the type of landslide thus far considered, the contained water, which is at once in part the cause and the means of the movement, accumulates relatively slowly, and it varies with the season, there being usually a more or less free drainage from the lower portion of such slides. There are, however, other landslides which are due to a relatively large and sudden accession of water to the unconsolidated materials of a slope. Such sudden accessions of water may be conceived to be produced in a variety of ways; such, for example, as a so-called "cloudburst" in a desert canyon, the slopes of which may be heavily mantled by earth and loose rock; or the breaking of a barrier which retains a bog or other body of water. For the present purpose, however, which is not that of an exhaustive systematic discussion of this class of phenomena, it will be sufficient to take note only of water which is expelled from the ground by the compressive action of the earthquake shock. Such landslides may be discriminated from earth-slumps by reason of their greater mobility, under the designation *earth-flow*. Earth-flows differ from earth-slumps not only in the much larger quantity of water involved in their mechanism as a moving mass, in the suddenness with which the water becomes efficient as a transporting agency, and in the rapidity of the movement; but also in the brevity of the entire process, its finality, and its non-recurrence.

Besides these two types of landslides, there is still another, which is immediately associated with earthquakes as a cause of movement. This is the slide of dry earth and rock upon precipitous slopes or their fall from cliffs. Soil or other loose forms of earth may participate in such landslides, but the material is usually composed chiefly of rock which becomes increasingly shattered with the progress of the slide. Such landslides will here be referred to as *earth-avalanches*. They are distinguished from both earth-slumps and earth-flows by the character of the material and by the absence of water as an essential factor in producing movement. They also differ usually in the marked acclivity of the slopes on which they occur. They differ from earth-slumps, but resemble earth-flows, in the finality or completeness of the movement. They are not progressive movements, but sudden events; and there is no recurrence of movement of the material involved, altho the avalanche may recur at the same place.

Besides these three types of landslide, another ought perhaps to be recognized. This is the form of superficial earth movement which occurred in consequence of the earthquake shock on the alluvial bottom-lands of many streams. It may appropriately be designated an *earth-lurch*. It varies from the opening of a mere crack, with a slight movement of the ground on one or both sides, to a violent and complicated deformation of the surface, usually accompanied by cracks and open fissures parallel to the trend of the neighboring stream trench. These cracks and fissures cut the ground up into strips or prisms which lurch toward the stream trench, or, it may be, toward an abandoned slough, the lurch usually being accompanied by a rotation of the prism. They are distinguished from all other forms of landslides by occurring on perfectly flat ground and by the fact that they are apparently referable directly and solely to the horizontal jerk of the earth movement during the earthquake shock.

A brief account, which in some cases amounts only to a mention, will now be given of some of the various kinds of landslides set in motion by the earthquake.

## EARTH-AVALANCHES.

Earth-avalanches were caused chiefly along the sea-cliffs of the coast on the morning of the earthquake, tho some also occurred on steep canyons within the zone of high intensity. On the coast the earth-avalanches were for the most part simply an exceptional incident in the normal process of cliff recession. Where the upland of the Coast Ranges approaches the shore, the horizontal corrasion of the waves maintains a steep sea-cliff; and the recession of the sea-cliff is effected by the repeated occurrence of earth-avalanches due to the undermining by the sea, combined with the disintegrating action of atmospheric agencies. There are thus always upon the face of the cliff masses of earth or rock, the fall of which is imminent and may easily be precipitated by a severe shock of earthquake.

The most notable of the earth-avalanches occurred where the sea-cliffs are highest and steepest. This happens on the coast of Humboldt County, between Cape Mendocino and Point Delgada. Not only are the cliffs here particularly favorable for large earth-avalanches, but the coast here is close to the line of the fault which caused the earthquake, and so received an exceptionally severe shaking. For many miles of coast there was a general slipping of rock and earth into the sea, down very precipitous sea-cliffs ranging up to over 2,000 feet in height. Between Shelter Cove and Point Arena, the sea-cliffs are not so high nor so continuous, but there was nevertheless a very general, and locally large, shedding of material from their face; and the sea was muddy for many days after the earthquake in consequence of the dejection of the débris upon the whore, within range of the attack of the waves.

From Point Arena southward to Fort Ross, the cliffs are low, being for the most part not in excess of 100 feet. Earth-avalanches were nevertheless of common occurrence along this stretch of coast. South of Fort Ross to Bodega Head the cliffs are again, as far as the mouth of the Russian River, several hundred feet high and very steep. Here again earth-avalanches were extensive. The rocks along this entire stretch of coast from Cape Mendocino to Bodega Head are prevailingly sandstones and shales. On the sea-cliffs on the north side of Bolinas Bay and west of the town of Bolinas, there was a very general crumbling and fall of the sea-cliff upon the beach. South of the Golden Gate, the most notable earth-avalanches were along the sea-cliffs between the city and Mussel Rock. This cliff has a length of about 6 miles and ranges in height from about 100 feet up to 700 feet, and is cut almost wholly in the strata of the Merced (Pliocene) series, which are inclined at angles varying from  $15^{\circ}$  to  $75^{\circ}$ . The rocks are for the most part rather soft and incoherent, tho there are numerous well-cemented and indurated beds in the series. This cliff converges on the fault at a small angle, and intersects it at its south end near Mussel Rock. The cliff was severely shaken and great quantities of earth and rock were caused to fall or slip down. The great earth-slump at Mussel Rock (Plate 129c, D) was also notably accelerated. A similar sudden movement of the ground occurred on the west side of Merced Lake, whereby a large section of the slope sank toward and into the lake, and a portion of the bottom of the lake was lifted above the surface by the deformational rotation of the collapsed ground.

To the south of Mussel Rock there were several small earth-avalanches along the cliffs, and numerous cracks were formed near the brink of the cliffs which will in future doubtless lead to further falls from the cliff-face. Near San Pedro Point there was a large movement of the earth on the face; of the high cliff. One earth-avalanche to the north of the Devil's Slide started about 500 feet above the shore and swept the face of the cliff, carrying away several hundred feet of rock. The slick occurred near the contact of sandstones reposing on granite, and both kinds of rock were involved. Smaller earth-avalanches occurred farther south on the sea-cliffs.

Inland from the coast there were numerous earth-avalanches caused by the earthquake on the walls of steep canyons. One of the most noteworthy of these was on the north side of a short but deep canyon west of Chittenden and close to the line of the fault. (Plate 126A.) The rocks composing the side of the canyon are the bituminous shales of the Monterey series. The slope rises very steeply for about 500 feet and was quite dry before the earthquake, altho it was covered with spring vegetation. Areas of bare rock appeared thru this vegetation. At the time of the shock several earth-avalanches were started, and these slid suddenly down the slope, part of the material filling the bottom of the canyon and part remaining on the less steep lower portions of the slope. The larger masses were broken off up near the brink of the canyon. There was apparently little or no rotation of the sliding mass. The result was to gorge completely the lower part of the canyon with rock débris, to widen the upper part of the canyon, and to expose extensive surfaces of unweathered rock.

On Deer Creek, in the Santa Cruz Mountains, an extensive earth-avalanche started near Grizzly Rock and moved westward down a steep, narrow canyon for about 0.25 mile. (Plates 124D and 125A.) It then changed its course thru an angle of about 60° as it entered a wider canyon of lower grade, and following this for another 0.25 mile, finally stopt at the Hoffmann Shingle Mill, which was wrecked. A fine growth of redwood, some 200 feet in height, was mowed down, and covered to the extent of 10 acres or more with from 30 to 60 feet of débris. The trees were from 3 to 10 feet in diameter. The main canyon was filled with earth and rock for an average width of 80 yards and a length of 400 yards. The entire area of the slide was about 25 acres. The difference in altitude between the point where the slide started and the shingle mill, where it stopt, is 500 feet. According to Mr. G. A. Waring, the slide material has a depth of 300 feet and is composed of soil, clay, and shale. Mr. E. P. Carey, who examined and photographed this interesting earth-avalanche, states that it originated in rock that broke away in pieces from the steeply inclined slope at the head of the gulch, leaving a large theater-like space, the bare, light-colored rock walls of which were in sharp contrast with the surrounding green vegetation. The movement was faster in the center or deepest part of the gorge than on the margins. The rock was in general piled up higher along both sides than in the center, and many pieces became entangled in the standing or uprooted trees. A steep-walled tributary to the southeast of the main gulch supplied rock material to the main avalanche, and the 2 streams joined much as confluent glaciers do. The material involved in the avalanche showed every gradation from powder to angular pieces 30 feet or more in diameter. The surface was uneven thruout. Near the mill a man was killed by a tree that fell as the avalanche was advancing.

Mr. Carey also reports another earth-avalanche located on the Petty ranch, about 4 miles southeast of the one just described. Here a huge rock mass, which embraces an area of about 12 acres at the headwaters of Cauley Gulch, broke away from a ledge and dropt, leaving a vertical scarp of 40 feet or more. The rock mass in this case was not shattered. It practically maintained its integrity. The narrow gulch below was unfavorable for free downward movement. As the block readjusted itself, its upper surface became nearly level, but was lower at the foot of the scarp than at its outer edge, thus indicating that it had suffered rotation.

At a point about 1.25 miles west of the Mindego sink, on the ranch of Andrew Stengel, an earth-avalanche is reported by Mr. Albert C. Herre. It is on a small tributary of Alpine Creek, and about 4 miles southwest of the San Andreas fault at the point where the latter crosses Black Mountain into the head of Stevens Creek Canyon. The creek here is in a narrow, steep-walled canyon in the bituminous shale of the Monterey series. The soil on the canyon side was very shallow, and at the time of the earthquake it was shaken down into the bottom of the canyon, leaving the walls absolutely bare in places



A. Maaoma earth-avalanche. Tuffs dipping in the direction of the slide. Slip included the crest of the ridge. E. S. H.

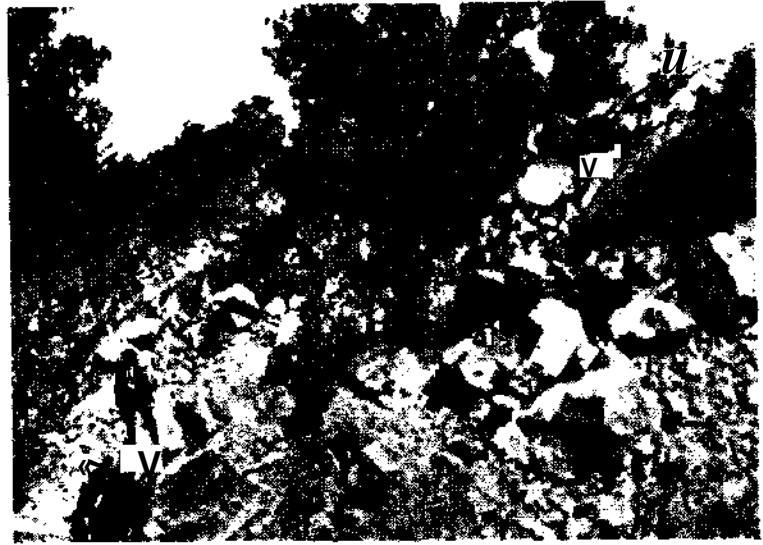

B. Maaoma earth-avalanche. A dot view. B. S. H.

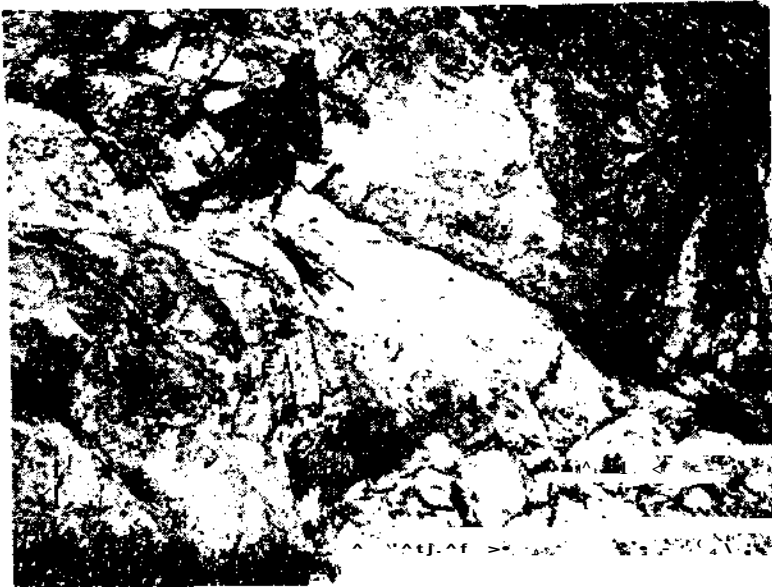

C. Earth-avalanche in granite on road near Half Moon Bay. E. D.



D. Deer Creek, Santa Grm Moantams. Earth-avalaachs from Griwlj Ptak. B. B.



A. Deer Oreet, Santa Cm Mountains. Lower end of earth-avalanche shown in Plate 124 B. E. G.



B. Scarp in the southeast quarter of section 15, township 18 south, range 12 east, near Cantua. G. D. L.

for a hundred yards at a stretch. The slide extends for 0.25 mile on both sides of the canyon. A similar earth-avalanche was caused by the earthquake on the ranch of Judge Welch, not far from Long Bridge and within 2 miles of Saratoga. Mr. Herre reports that here the soil on the northwest side of a small creek coming down from the Castle Rock Ridge, was shaken down for perhaps 0.5 mile, tho not continuously. In places the slid material filled up the creek-bed and totally changed the contour. It destroyed the road to the ranches farther up the canyon, and wrecked some bridges. Along the upper part of the area affected, a vineyard was destroyed; while farther down the canyon a heavy forest growth, consisting mostly of redwood, oak, alder, and laurel, was obliterated. This slide lies in the path of the San Andreas fault.

Mr. Herre further reports a large slide on the Mine-lego Ranch, 20 miles southwest of Palo Alto. Here, on the north side of Alpine Creek, a tract of some 50 acres sank at the time of the earthquake, with little or no apparent forward movement. The tract sloped to the south and west, and formed part of a great, open hill pasture, with trees and underbrush about the lower or creek side. The creek-bed itself is filled with a growth of Douglas spruces and other trees. The land, which before the earthquake was steeply inclined, is now comparatively level, the eastern and northern part having sunk perhaps 100 feet, while that on the west has sunk but 10 or 15 feet. The surface of the sunken tract was greatly seamed and cracked, and part of it was flooded, owing to the springs uncovered; but otherwise it was unchanged in appearance. There was no piling up of earth, nor sliding of one portion over another. A fence crost the tract, and the posts on it sank so that but a few inches protruded above the surface; while some Douglas spruces also sank several feet into the earth. A number of cattle were on the land at the time of the earthquake, but were uninjured. It was a work of great difficulty to remove them, block and tackle being necessary. The creek-bed was apparently not affected, nor were the trees in it disturbed. There was no apparent movement of the earth into the canyon, but the whole mass seems simply to have been dropt from a steep slope to a nearly uniform level, surrounded by the high, blank, almost perpendicular walls of earth and rock from which it had been sundered.

Many other earth-avalanches of minor importance were caused by the earthquake in various parts of the Santa Cruz Mountains. At Hidden Villa, 2 miles northwest of Black Mountain, large blocks of rock arc reported to have rolled down the slopes. There were numerous slides along Stevens Creek, due chiefly to the caving of the creek banks. Along the ridge road southwest of Stevens Creek, sandstone blocks, sonic of them 6 feet in diameter, rolled down the hills toward the creek. Near Half Moon Bay considerable masses of granite were dislodged on a steep slope, (Plate 124c.) On the road along Pilarcitos Creek, an earth-avalanche brought down big blocks of sandstone upon the road. (Plate 126B.) At Boulder Creek a large portion of the soil was shaken loose from an abrupt hill 150 feet high, and fell to the level of the creek, carrying trees with it. At the north end of Ben Lomond Mountain, a slide carried trees and brush down to tho creek. Near Olive Springs, 12 miles north of Santa Cruz, an earth-avalanche demolished Loina Prieta Mill and killed several men. At many places on the south side of Cork' Madera Creek, huge masses of rock had been thrown down from the stoop bluffs into the road, completely blocking it. About a mile from the summit of tho ridge, where the Alpine road outers the Pago Mill road, a slide carried away the entire roadbed for a distance of about 300 feet. On PurLssima Crook a slide filled the road for a length of about 100 foot; another, between 0.25 mile and 0.5 mile long, dammed the creek to a depth of 25 or 30 foot. A large; slide close<sup>1</sup> to Wright Station partly dammed the stream. On the western slope of the ridge just west of Skyviand, several earth-avalanches were caused by the shock; and great slides of a similar character occurred on both sides of Aptos Creek for 0.75 mile. Besides those, there were many smaller earth-avalanches

in many parts of the Santa Cruz Mountains which can not be enumerated. There were also several such slides on the granite slopes of Montara Mountain, farther north in the San Francisco Peninsula.

In the Coast Ranges to the north of the Bay of San Francisco, earth-avalanches were not so common away from the coast as they were in the Santa Cruz Mountains. There were, however, two notable ones which deserve mention here. The first of these is the Maacama slide, 6 miles east of Healdsburg. (Plate 124A, B.) The slide is about 0.125 mile wide at the top, and 0.5 mile long. The rock is a stratified volcanic tuff, and the slip was down the dip of the beds. The avalanche cut its way thru a fir forest and dammed Maacama Creek. The other is the earth-avalanche which, on May 1, 1906, dammed Cache Creek to a depth of 90 feet at a point 4 miles below the confluence of the north and south branches of the creek. The rock which fell is red sandstone. The width of the slide is 300 feet and its height is 500 feet. The dam thus formed broke one week later. This earth-avalanche can not be so directly referred to the earthquake of April 18 as the others heretofore described; but it was probably indirectly caused by the shock.

#### EARTH-SLUMPS.

By far the most common manifestation of landslide phenomena was that here referred to as earth-slump. It would be wearisome to attempt to mention all the various earth-slumps stimulated by the earthquake, even if information were sufficiently detailed to make this possible. Only two of the more important slides which have come under the observation of geologists will be noted.

*Cape Fortunas earth-slump* (F. E. Matthes).—This landslide, immediately south of Cape Fortunas, is by far the most extensive one on the northern coast. (See plate 127A, B.) In May, 1906, it projected into the ocean for about 0.25 mile, like a hummocky headland of irregular outline; indeed, it formed a new cape on the coast-line, but will doubtless rapidly be cut back by the action of the waves. Its length, in the direction of its movement toward the ocean, is estimated at little short of a mile; its width varies from 0.25 mile to 0.5 mile. Its total descent, from the summit of the higher scarps at its head to the level of the sea, is probably less than 500 feet. Its surface is exceedingly irregular, with many large humps and hollows. Over large areas the sod is more or less rhythmically broken by deep cracks extending at right angles to the direction of movement. These cracks are only a few feet apart, and the sod-blocks between them lie mostly in tilted attitudes, making the area exceedingly difficult to traverse. The general aspect is not unlike that of a much crevassed glacier. In some places, however, the mass seems to have been torn apart so completely that the sod is not merely broken but almost swallowed up or buried, the browns and yellows of the under soil being the prevailing tints. Around its head are a number of steep scarps, from 100 to 200 feet high. They are especially prominent on the north side, and again toward the southeast; but over considerable stretches between these two sets, the broken surface of the slide joins the unbroken hillsides to the east without significant offset. Owing to this, the slide is easily approached from the wagon road (from Centerville to Cape Town), which passes close by its head. The longitudinal profile of the landslide is one of gentle slopes for the most part; its declivity is not at all great, and in a few places even reversed slopes occur. Its noteworthy feature is not its vertical drop but its great forward movement. In a sense it has flowed like a partially plastic mass, expanding and advancing 0.25 mile beyond the coast-line, but descending only a few hundred feet.

In its general aspect, as well as in the nature of its movement, the Cape Fortunas landslide is altogether different from those observed farther south, particularly along the mountainous coast both north and south of Point Delgada, which, in effect, did little

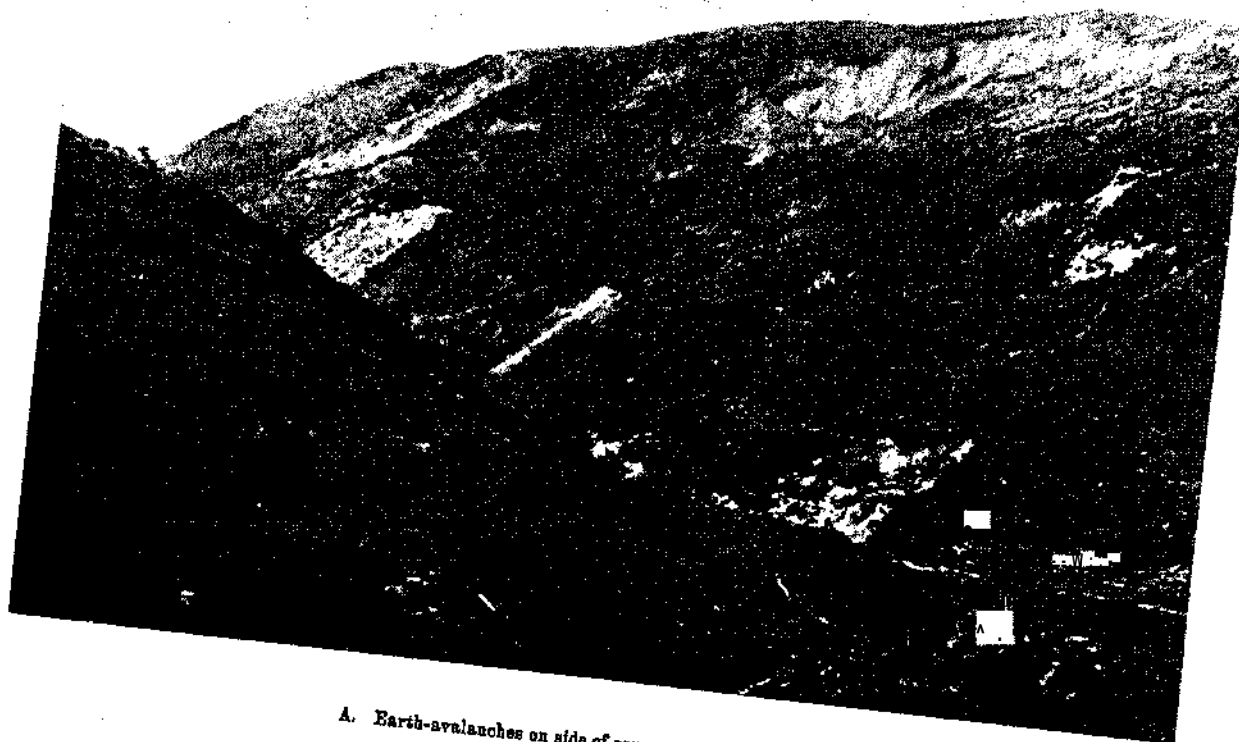

A. Earth-avalanches on side of canyon near Chittenden. A. C. L.

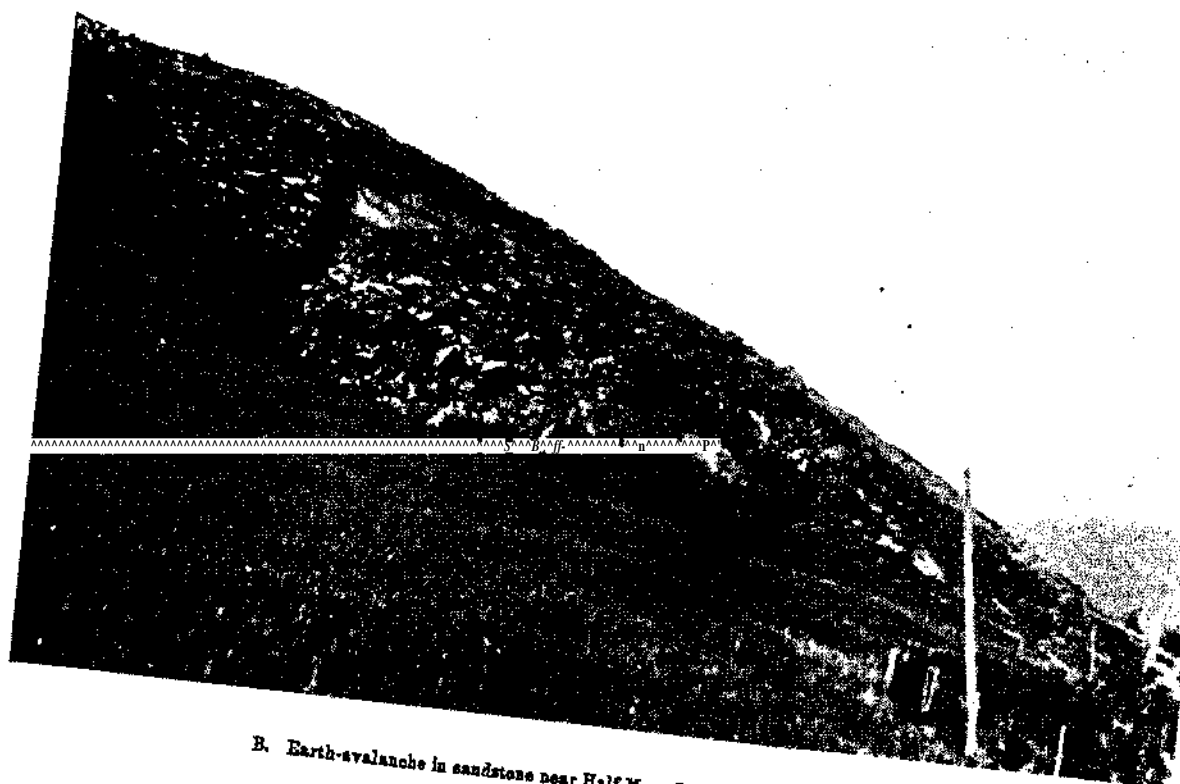

B. Earth-avalanche in sandstone near Half Moon Bay. Slip on bedding planes. E. D.





A. Earth-slump at Oape Fortunas, Humboldt County. A. S. E.

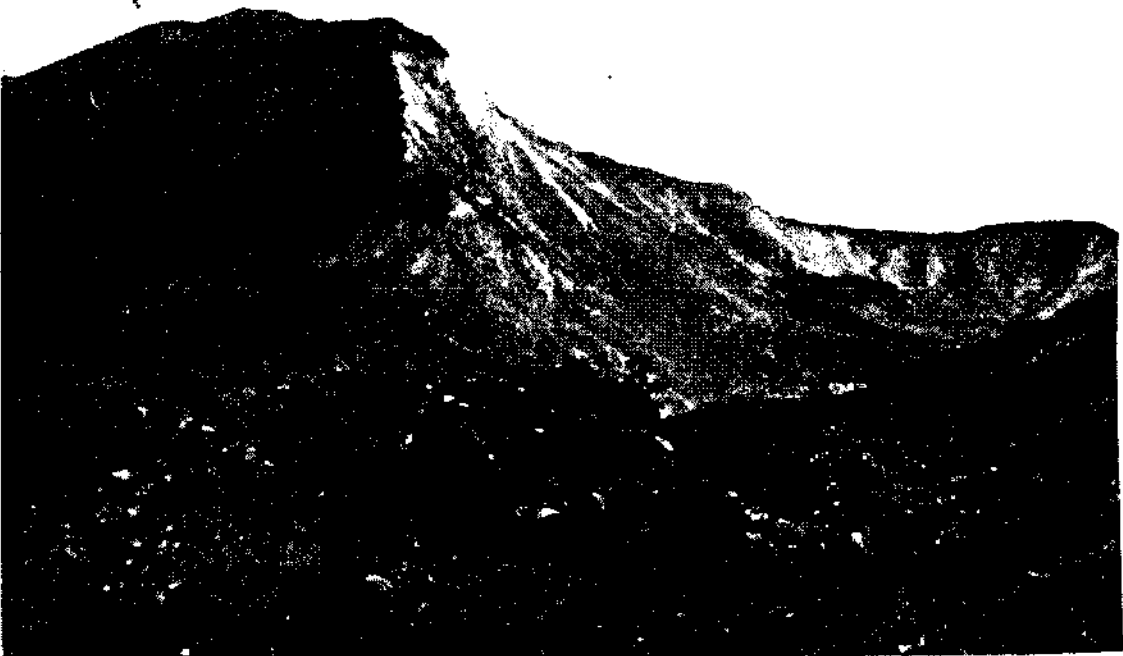

B. Earth-slump at Cap Fortanw, HamHMt Oesmtj. A. 8. E.

else than revive a series of old landslide facets. This may not be apparent to an observer on the beach, but is quite striking when the coast is viewed in its entirety from a vessel off-shore. These facets existed before this earthquake, and had been recognized as such. They are conspicuously outlined against the dark timbered slopes behind them, rising from 1,000 to 2,000 feet above the shore, and affording an important series of landmarks for the mariner. In strong contrast with these bold mountain forms is the region in which the Cape Fortunas landslide took place. The land here can scarcely be called mountainous; and while it breaks off in cliffs at the coast and is traversed by many fairly deep draws, it is essentially a region of subdued relief. Great declivities are notably absent, except in the sea-cliffs, and even these are only a few hundred feet high. At the same time, evidences of former landslides may be seen on every hand. They are not extensive, as a rule, and are as likely to occur on gentle slopes as on steep ones. In a few cases only is a marked downslip noticeable, resulting in the uncovering of a steep scarp; in nearly every instance the dislocated mass appears not so much to have sheared off and dropt from its former position, as to have expanded or slumped, with an accompanying subsidence of its surface. The billowy and irregularly pitted appearance of these areas, together with the rank vegetation that covers them, afford the principal marks of identification. Both from their characteristic form, suggestive of plastic flow, and from their mode of occurrence, it seems reasonable to infer that ground-water plays an important rôle in their genesis. They are apparently masses which have changed their shape in obedience to a lessening of cohesion in their interior, through saturation with water. Whether the movement be initiated by an earth-tremor or not, it is in every case essentially an adjustment to a more stable position, rendered necessary by a change in the physical constitution of the mass.

It is to this category of landslides that the one at Cape Fortunas belongs. While there are scarps in various places at its upper end, these are really insignificant features alongside of the extensive tract of the slide itself. What downslipping occurred on these scarps was merely an incident in the entire movement. Both in the large ratio between its horizontal advance and its vertical drop, and in its general appearance, the Cape Fortunas landslide is closely analogous to the numerous lesser slides referred to; and there is good reason for the belief that, like them, it consisted essentially of an adjustment of equilibrium in a partially water-saturated mass. It probably had long been imminent before the earthquake started it,

*San Pablo earth-slump.* — At the time of the earthquake a landslide occurred on Mills' ranch, which is about 4 miles east of San Pablo. The slide is interesting from the fact that a previous geological mapping of the region indicated that the point where it occurred was on the line of a fault extending in a northerly and southerly direction through the Sobrante Hills. The slide was examined by Mr. E. B. Larson, who describes it as follows:

There are many other landslides in this vicinity, showing that the country is subject to such slides. In this particular case, one of the Castro boys informed me that the main part of this slide began during the winter rains, and had fallen a foot or more during these rains. The balance of the fall occurred the morning of the earthquake. The slide is on the east slope of a steep hillside and extends from the top of the hill nearly to the bottom, about 400 feet on the slope. The width is about 1,500 feet. At the northeast corner the scarp is greatest, reaching perhaps 50 feet. It gradually decreases, and is very slight for the southwest 700 feet, in this southwest 700 feet the only evidence of a slide is the crack near the top of the hill. The north 800 feet of ground shows every evidence of sliding. The dry ground is much cracked, and these cracks extend up and down the hill near the scarp and along the hill where the ground has been piled up. In some places there is a network of cracks. On the south side of the main slide the ground has piled up about 10 feet. This extends along nearly all of the south side, and this tendency to pile up to the south is shown in other places. Moreover, the north side shows that the ground has pulled

away toward the south. The above shows that the movement was not directly down the hill, but was more to the south. The formation is sandstones and shales, with considerable soft surface soil.

The same slide was subsequently visited by Mr. F. E. Matthes, and the following descriptive note is by him. (See figs. 68 and 69.)

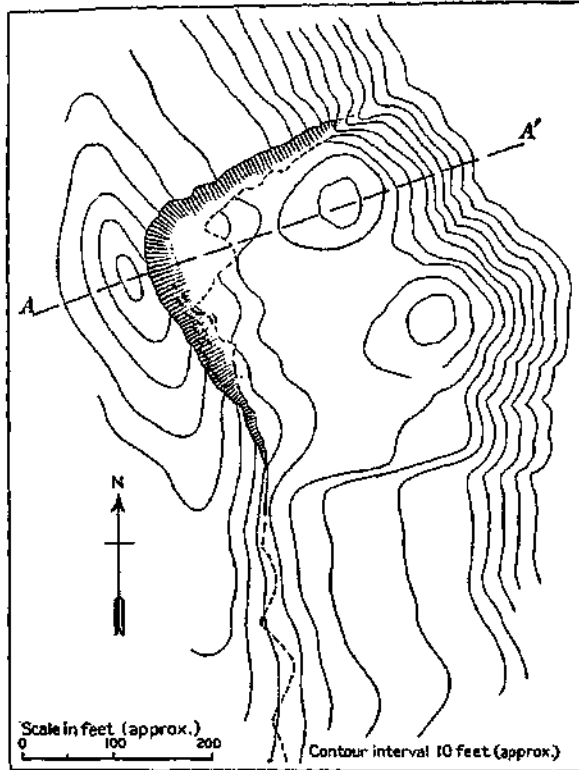

FIG. 68.—Map of landslide caused by the earthquake east of San Pablo.

The slip occurred east of a high ridge at the southern end of the Sobrante Hills. It covers the northeast half of an area whose terraced nature is indicative of a former landslide of much larger dimensions. The accompanying sketches show the general outlines, and a cross-section of the slide. It will be noticed that the slide does not extend all the way down the slope, its lower edges being fully 100 feet or more above the bottom of the gulch. The lower slopes were not materially changed, and but little debris fell into the stream-bed.

A steep scarp has been produced east of the crest of the ridge. The downslip along this scarp does not exceed 50 feet, and decreases both to north and south. Along the north edge there has been a marked movement down and southward, the scarp there averaging 10 feet. Along the south side, on the other hand, the loosened mass had advanced over the old surface, presenting a bulging and cracked frontal scarp some 6 feet high. It appears from this that the movement took place, not along the line of greatest declivity, but in a direction somewhat more southward, as indicated by the arrow. The 2 hummocks probably existed before the slip occurred, but judging by their greatly cracked and rent surfaces, it seems likely that their height has been slightly increased. The main crack, which extends southward from the upper scarp, continues along the hillside in irregular zig-zags for some 300 feet south of the slide. (See plate 128A, B.)

Other earth-slumps referred to under the section on the Distribution of Intensity are shown in plates 125B and 129A, B, V, D.

#### EARTH-FLOWS.

*Mount Olivet Cemetery* (A. C. Lawson). — Perhaps the best illustration of an earth-flow caused by a sudden accession of water to the incoherent materials of a slope, in consequence of the earthquake shock, is that which occurred in the upper part of Mount Olivet Cemetery, near Colma, 9 miles south of San Francisco. The locality is at the base of the San Bruno scarp, and about 2.75 miles northeast of the San Andreas

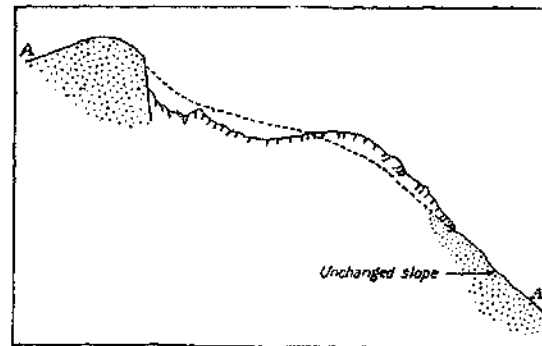

FIG. 69.—Section of landslide shown in fig. 68, along the line A-A'.



A. Eaitli-alump east of Saa Pablo. F. E. M.



B. Earth-slnmp east of San Pablo. P. E. M.



A. Earth-slip north of Tomales, carrying railway roadbed with it. Track was straight before earthquake. R. S. H.

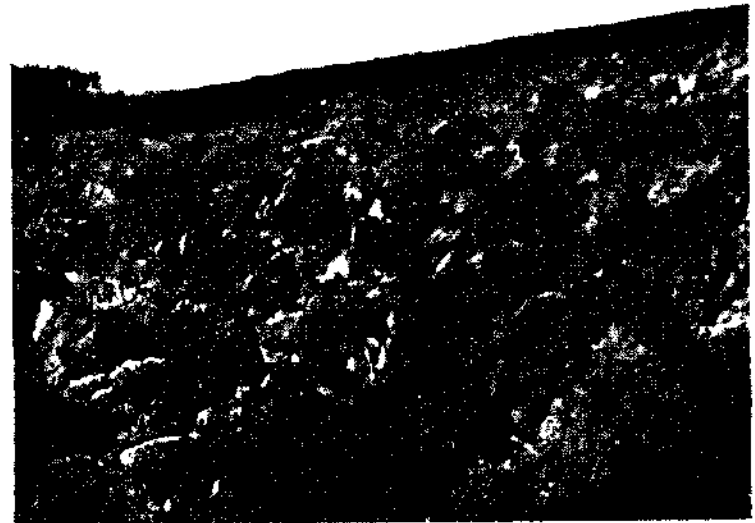

B. Earth-slip 3 miles northeast of Tomales, at Freeman's, E. B. H.



C. Earth-slip at Mussel Rock. Old slide suddenly accelerated by earthquake, 0.



D. Scarp of Mussel Rock earth-slip. 0.



A. Earth-flow at Mount Olivet Cemetery, Source of flow looking down. A. O. L.

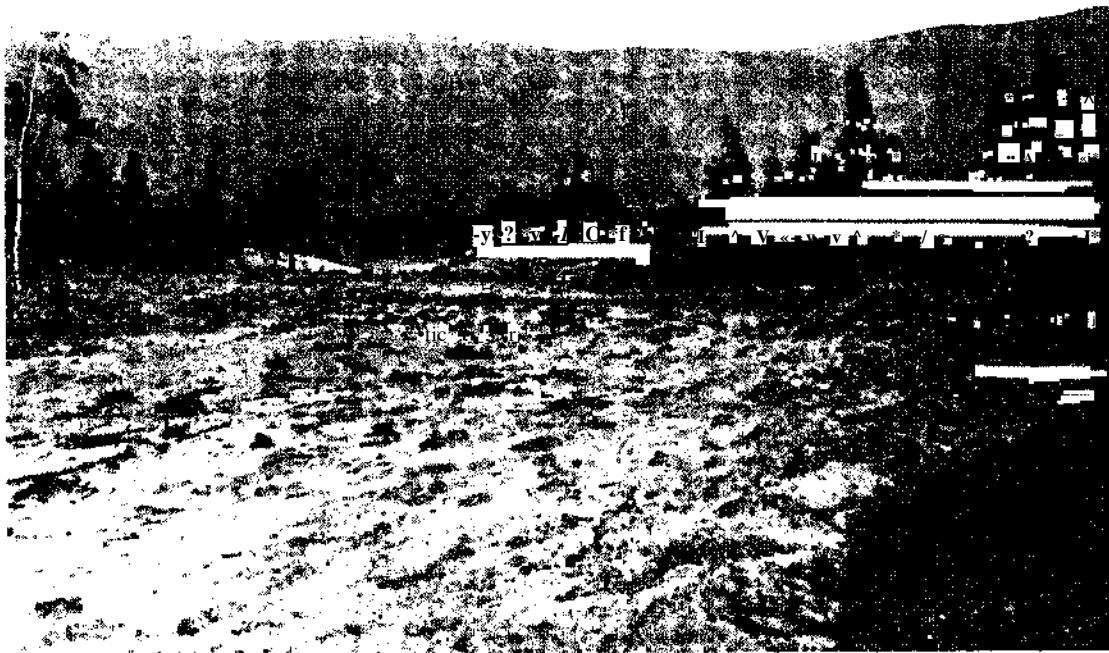

B. Earth-flow at Mount Olivet Cemetery. Path of flow, looking up. A. O. L.



A. Earth-flow, Mount Olivet Cemetery, at base of San Bruno soap. Looking northwest, A. O. L.



B. Earth-flow near Mills east of Half Mora Bay. B. A.

fault at Mussel Rock. The steep slope of the scarp is underlain by hard sandstone of the Franciscan series, with but a thin veneer of soil, or none at all. At the base of the scarp is the gentle slope of Merced Valley, underlain here by Pleistocene and recent sands. The sands, partly eolian, lap up on the lower flanks of the scarp, and mantle the trace of the auxiliary fault which follows its base. The sands thus vary in thickness from a feather edge to an unknown thickness, which it is believed may be as much as a few hundred feet at no great distance from the base of the scarp. Traversing the gentle slope of the valley-floor are several shallow arroyos, which head in incipient ravines in the face of the scarp. At the moment of the earthquake there was a sudden outgush of sand and water at a point at the upper end of the cemetery, close to the base of the scarp and quite near, if not immediately upon, the line of the buried fault-trace. This stream of sand and water, admixed with the loam of the slope, flowed rapidly down the course of a shallow arroyo on a grade of about 1:25 with a depth of from 13 feet in its upper part to about 3 feet in its lower. The front of the stream stopt abruptly at a point just beyond the roadway about half a mile from the origin. The flow was so rapid that it carried away many small trees; a wind-mill was wrecked and the heavy concrete blocks which served for its foundation were swept down, with other debris. One of the pumping stations of the cemetery was demolished by it, and 2 horses were carried off their feet, and were extricated afterwards with difficulty. (See plates 130A, B and 131A.)

According to Mr. M. Jensen, the superintendent of the cemetery, the entire flow had been accomplished within 3 minutes from the time of the shock, and he was at its source within 20 minutes after it occurred. The height of the flow within a few hundred feet of its source was attested by the mud upon the trunks of some eucalyptus trees near its margin. This mud extended up to 13 feet above the bottom of the arroyo. This, however, doubtless indicates the height of the front of the stream as it past this point. As the flow advanced, its surface near its source rapidly dropt; and by the time the front had reached the roadway the stream was probably no deeper at its source than at its terminus. Indeed, it seems to have been somewhat less, as there was a marked tendency for the sand to pile up at the front by reason of the negative acceleration at the front due to loss of water. After the moving mass had come to rest and partially dried out, it was found that it had left a streak of muddy sand on the bottom of the arroyo averaging 100 feet wide and about 3 feet thick. Taking the length of the flow as 900 yards, this gives the total volume of the compacted wet sand as 89,100 cubic yards. The cavity in the slope caused by the evacuation of this sand and loam was not measured, but was estimated to have a width of 150 yards, a length of 300 yards in the direction of the flow, and an average depth of 2 yards. On this estimate, its volume would be about 90,000 cubic yards, which agrees quite closely with the estimated volume of the material ejected.

The sand, after it had ceased flowing and had been drained and compacted, undoubtedly held in the voids between the grains not less than 25 per cent of its volume of water. An additional 15 per cent would probably give it the necessary fluidity for flow down a slope of 1:25. But as the flow was swift, there was an excess of water, so that probably 25 per cent would have to be added to give it the properties manifested in the actual flow. The sand, however, in its original position before the time of the earthquake, probably did not contain more than 20 per cent of water, since the upper or soil layer had been somewhat dried out by the air. To the original sand of the slope, therefore, there must have been added 30 per cent of its volume of water to cause it to behave as it did. This amounts to 27,000 cubic yards. This water came from ground immediately below the source of the flow; and it came in a moment, at the time of the earthquake. It is only another way of stating the facts to say that it was squeezed out. There was



no disturbance of the soil on either side of the cavity, even in its immediate vicinity. On the shoulder to the southeast, where the trace of the auxiliary fault passes over practically bare rock, no evidence of movement was detected on critical examination. The expulsion of the water was a purely local phenomenon. In attempting to explain the cause of it, or to ascertain the local subterranean conditions which conspired with the earthquake shock to bring about the event, it should be noted first that on the line of the fault-trace there are longitudinal depressions, which appear to be in part structural and in part due to erosion following the fault. If one of these depressions should locally have the character of a sink, without free drainage, then the sand which filled it would be saturated with water in consequence of the rains of the previous winter. It is believed that the compressive action of the earth-wave passing through such a pocket of saturated sand, and reflected perhaps more than once from the containing rock walls, would be adequate to expel 27,000 cubic yards of water from the deeper portion and add it suddenly to the more superficial portion of the formation, thus bringing about the earth-flow. It may be stated in this connection, although it has no conclusive bearing upon the question involved, that the sands of the valley generally are an abundant source of well water, and that there is a surface well within a few hundred feet of the source of the earth-flow, lower on the slope. There was very little water in the arroyo before the earthquake and a very insignificant stream afterwards, the latter being probably referable to the drainage from the ejected sand.

*Vicinity of Half Moon Bay* (Robert Anderson).—The earthquake shock caused the appearance of an unusual amount of water at the surface in many places. This was noticeable in the vicinity of San Bruno, where several short streams running into the bay were flooded by an unusual volume of water during the first days following the earthquake, in spite of the fact that it was perfectly clear weather. Instances have been cited in the present writer's notes on the results of the earthquake in the San Francisco Peninsula, of water with a salty taste or milky color issuing from springs after the shock, and of streams being muddy and flowing with increased volume. These facts, and the fact that water continued to issue after the earthquake at the points where earth-flows occurred, and where it had not been in evidence before, and that earth-flows occurred sometimes on convex slopes where the concentration of water under normal conditions would be unlikely, seem to be explainable only by the theory that underground conduits were disturbed and made more open, that new channels of escape for the water were formed, and that water was actually squeezed out of the hills in some cases by compressive movements. This flowage of water to the surface, in increased amounts and sometimes at new places, caused the formation of the earth-flows. The places where these debacles occurred may or may not have been previously points of concentration of seepage water, and the soil already in part saturated. But it is supposed that the content of water was increased by the shock, possibly in extreme cases by the gushing up of a large volume; and that this increment of water, with its disintegrating, weighting, lubricating, and direct forcing power, aiding the attack of the shock on the soil, was the main cause of the earth-flows.

There is little evidence as to when the flows were first set in motion; whether at once during the shock, or later after the lapse of some brief period of time that may have been necessary for the accumulation of the water in extra large quantities.

Earth-flows originated in valleys, in gullies, or on hillsides. Where the weight of the earth, combined with the weight of the added water, was sufficient and the substratum of the soil was rendered plastic, gravity caused it to creep like a lava-stream, leaving a hollow in the place from which it came and a fan or tongue of debris down the slope below. Movement was especially apt to ensue where the ground had been previously wet, the intensity of the earthquake shock being particularly great at such points and



A. Earth-flow in Mills east of Half Moola Bay, R. A.



B. Earth-flow in small valley near Half Moola Bay, E. A.

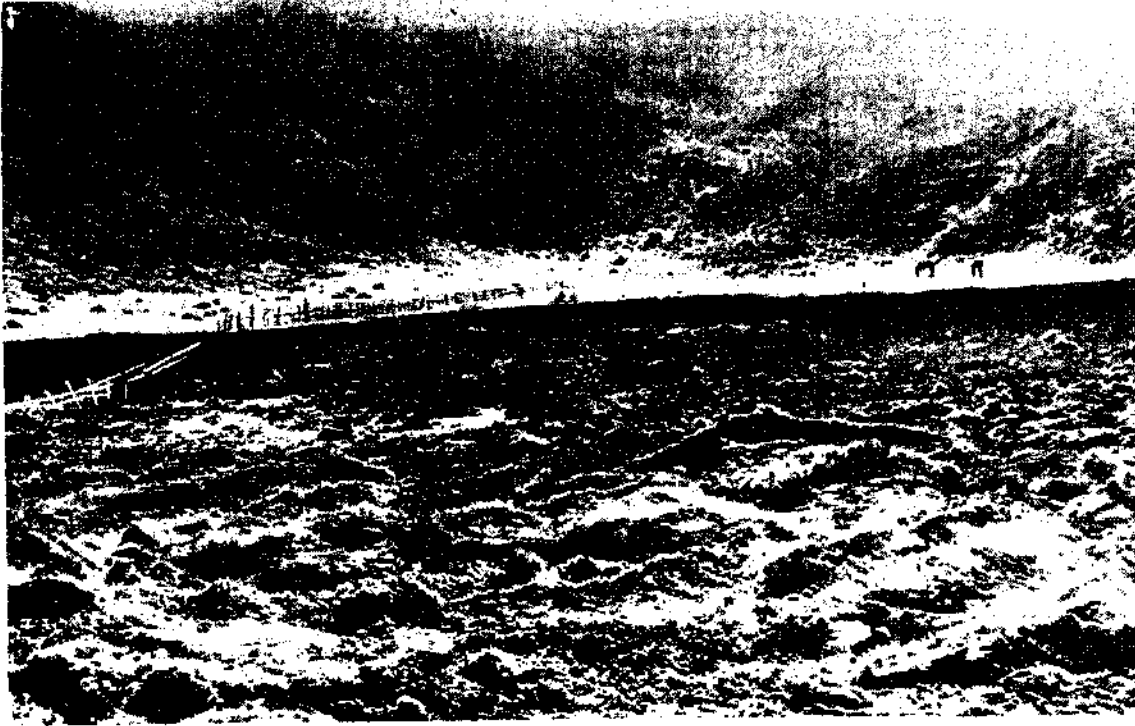

A. Earth-flow shown in Plate 132 B, illustrating floor of cavity from wMoli flow oame. E. A.



B. Earth-iow 4 miles east of Half Meoa Baj. E. A.

the tendency of the vibrations being to set the mass in motion. Earth-flows occurred in many places in the Coast Ranges, and probably thruout the region in which the shock was heavily felt. The writer found many of them, large and small, on the San Francisco Peninsula and in the Santa Cruz Mountains, also in the Mount Diablo and Mount Hamilton Ranges.

Following are descriptions of 5 earth-flows that occurred on the morning of the earthquake in the neighborhood of Half Moon Bay, which is on the coast 25 miles south of San Francisco:

One of them was formed in the hills bordering the terrace at Half Moon Bay, immediately south of Frenchman Creek, 1.5 miles north of the town, and a mile from the sea, at an elevation of 100 feet. It is pictured in plate 132A. At this place the earth caved away in a crescent-shaped area on a slope of only  $18^\circ$ , and flowed out in two long arms so as to leave a hole 4 feet deep, surrounded by vertical walls of unaffected soil. The flow occurred at a fairly high point on a gently undulating incline. The discharged earth was divided by a mound, at a point 150 feet below the summit of the arc, and followed two courses which were determined by gullies on both sides. Much of the débris overflowed the central mound at the same time, and inundated the barley fields to a depth of 2 to 4 feet, for 100 feet farther. On both sides of the central mound the caving away continued to the same depth. In the left-hand fork it stopt within a few feet, and the flow did not extend very far beyond. In the right-hand fork a cut 100 feet long and 50 feet wide was made, the earth flowing down from it 250 feet farther over the grain field, as shown in plate 132A. Thus the whole length of the slide was 500 feet. The width of the main hole was on the average about 100 feet, and the length, as already mentioned, 150 feet not including the arms.

In this hollow in the hillsides many dry blocks of sod carrying growing grain — usually in an upright position — were left stranded 4 feet below the surface of the hill by the removal of the subsoil. The fence that crost this area was broken and carried away and partly buried. Where the caving ceased in the right fork, a ridge of debris was piled up across the mouth of the hole, much higher than the stream of loose material that flowed farther. Similar ridges were heapt up across the path of the flow, where the breaking away of the hill stopt in the other arm and at the upper end of the central mound.

The south or right arm of the flow extended down the hill at an angle gradually decreasing from  $18^\circ$  to less than  $5^\circ$ . Large parts of the fence were carried on its surface for 300 feet.

Plate 132A gives a detailed view of the lower extremity of the right arm. The stream came to an abrupt stop, like a quickly cooled lava flow, and preserved a face 1 to 2 feet in height above the grain field. The surface of the flow consisted largely of blocks of sod, usually almost upright, which were carried down from the hole without much moistening, or transformation into material capable of flowing. The bulk of the flow was a moist aggregate of earth fragments possessing something of their previous form and grading into mud, which assumed a semi-fluid consistency underneath. The bottom of the hole, and the flow itself, remained too muddy to walk on for weeks after the earthquake, and the field below the lower end of the large arm was left marshy, tho it had not been so before. It is to be noted that several fairly heavy rains followed the earthquake after an interval of several days, and before these earth-flows were visited; but these were not sufficient to account for the amount of moisture observed. The chief effect of the water was in the ground at a depth of 3 or 4 feet below the surface. It rendered the soil sufficiently fluid to enable it to flow down the gentle slope, probably partly oozing from under the surface crust ami partly transporting the sod with it. Most of the surface was carried down with the main flow, the stranded sur-

face blocks that remained in the cavity being accountable for as fragments from the broken edges subsequently giving way and being carried only a short distance as the upper end of the flow came to rest. In this way, probably, the walls were trimmed, for the cut in general was left remarkably clean.

Another flow of similar character took place 3 miles north-northwest of the town of Half Moon Bay, on the creek next west of Frenchman Creek. It is shown in plates 132B and 133A. On the morning of the earthquake an acre of the gently sloping alluvial floor of a broad, short valley tributary to the main creek on the east caved and flowed out, leaving an excavation 10 feet deep, where before it had been almost level and where there had been no stream channel. In this case, the water already gathered in this basin-like valley, which here had had no means of prompt escape, was an important aid in the formation of the flow, aside from the sudden accession of water that probably caused the earthquake. The presence of a large amount of water and the forcible movement during the earthquake shock resulted in the loosening and undermining of the ground and its transportation as a fluent mass. The angle of slope was about 5°. The flow carried out thousands of tons of earth in this manner and spread it over about 2 acres of meadow land, to an average depth of 1.15 to 3 feet.

Plate 132B gives a view of this earth-flow, showing the pit from which it was derived. Covering much of the surface of the flow and the floor of the hole are to be seen blocks of sod which have been carried right side up as if the material had moved *en masse*. The amount of water in evidence shows clearly how the earth was softened and enabled to move. The picture was taken two weeks after the earthquake. At that time water was still seeping up from underground, and out of the lower portions of the broken walls, while the ground near the surface of the valley was quite dry. The water had formed two definite rivulets thru the débris, at an elevation above the surrounding meadow, and was running in continuous streams, fast cutting a channel for itself and removing the soft material. Considerable water was dammed back in the hole by a 4-foot ridge of débris piled across the mouth of the hole, as in the case of the previously described earth-flow. This mound of earth, along the line where the stream left the caved-in area and flowed over the preexisting slope, was probably piled up at the last by the remnants of the flow gliding down and heaping themselves up as a barrier at the mouth of the hole.

The cavity, about an acre in extent, has 10-foot walls which gradually decrease in height lower down the valley, the bottom of the hole being more nearly level than the valley-floor. Plate 133A shows part of this flow in detail.

Some of the great blocks of sod around the edges have not been removed, altho the material from underneath has gone. Concentric cracks not visible in the pictures extend around the edge of the hole and for 50 feet above its upper end, showing that the area affected is broader than appears at first sight, and that the work is not yet all accomplished. The material of the valley-bottom is a coarse, arkose earth, derived from decomposing granite, and containing many rock fragments.

A flood of earth covers about 2 acres of the meadow. Water was present in this earth-flow in greater amount than in any other that was examined. The nature of the material may be judged of by the abrupt face of the stream where it stopt. The edge makes a steep angle with the meadow and rises to an average height of 2 feet above it. Yet the fact that this mass of earth was able to move more than 300 feet after it left the lower end of the hole, and spread into an even and thin layer over a wide extent of nearly level meadow, shows that it was fairly soft. It was moved on a basal layer of semi-fluid mud and sand, with the aid of the weight of the overlying and partly disintegrated earth.

The largest of the earth-flows seen occurred in the canyon south of the house of Mr. Nunez, 2.5 miles east-northeast of the town of Half Moon Bay, at an elevation of about 500 feet. It originated in a manner similar to the others, but in a canyon along which there is a distinct but ordinarily dry stream channel. A long, irregular hole from 4 to 7 feet deep was excavated near the head of the valley, and a great volume of earth flowed down its curving course for 0.25 mile, as far as the Nunez house, and there stopt, being in part diverted into the main creek to which the valley is there tributary. According to the testimony of witnesses, the flow reached the end of the 0.25 mile in 0.5 hour after the earthquake shock. It was seen gliding slowly down and engulfing the orchard just back of the house. According to observers on the Nunez ranch, the earth-flow was not accompanied by any water; but two weeks later, when examined by the writer, it preserved every evidence of having been muddy. Especially was this true at the bottom, where great masses of mud still had the consistency of jelly. It is probable that there was no flowing water on the surface of this or other earth-flows at the time of their formation, and that the presence of water in the flow was not evident to the casual observer because of the comparative dryness of the material on its upper surface.

The slope of the canyon down which the moving body of land crawled is about  $25^{\circ}$  near the head and decreases to  $15^{\circ}$  farther down. The flow filled this to a width of 100 feet on the average, and to a depth varying from 10 to 20 feet. The inertia of the mass is illustrated by the fact that in the early stage of the flow the earth was piled 20 feet higher on the hill, on the inside of the big curve made by the canyon, not far below the pit, than it was when the flow came to rest. The marks at this elevation were probably made very soon after the main mass was discharged from the cavity, before it had spread very widely. The central portion of this earth-flow is pictured in plate 131B, where it appears as a ridge many feet high rising above the tall grass on the hillside, on the right of the picture. The pressure of the material at the head of the flow, as it started, was so great that the earth bulged up over the sides in places, in such a way as to force upward great blocks of sod and turn them on edge or completely over, away from the rim of the hole.

The flow assumed the form of two lateral ridges and a central depression, or channel. The ridge on the west or inner side of the curve was considerably the higher. The form was due partly to the concavity of the valley; but chiefly, it is thought, to the tendency of the more fluid material to follow the deepest possible path along the gully under the center of the flow. Thus the drier material was retarded at the sides. Subsequent to the first starting of the flow, a stream of semi-fluid mud and sand continued to run down the central channel, covering its sides with a coating of mud and leaving flowage striations on it. This channel and its markings are exhibited in plate 131B. Two weeks after the earthquake, when the photograph was taken, water was running in this channel and had cut down into it several feet deeper. Its bottom, however, was still from 5 to 10 feet higher than the bottom of the underlying preexistent water course, where water had not flowed before at this time of the year. The man in the picture is standing at the bottom of the gully. To the left of him, the hammer and note-book mark the top of one of the parts of the lateral ridge which is here divided into several hummocks. To the right is the other and higher lateral ridge. The foreground was formerly covered by a dense thicket of willow trees. These willows have been completely buried, except at the sides where some dead brandies protrude. A fence that erost the canyon was torn away for 100 feet, and not a trace of it could be found. The fence shown in the picture is one newly built in its place.

Two other smaller earth-flows occurred just over the hill westward from the last one described. They are shown in plate 133n, the canyon on the left being the one occupied

by the Nunez flow. One of these 2 earth-flows, that at the right of the picture, started near the top of the ridge in a depression in the slope, formed a hole 75 feet long and 40 feet wide, and coursed down a narrow runnel having a gradient of  $25^\circ$  to the bottom of the hill, a distance of 600 feet. Enough earth issued to fill up the rather deep ditch in the gully clear to the bottom of the hill and to bury the grain field on both sides to a depth of 1 to 2 feet. In this case, as in the preceding one, there were formed lateral ridges higher than the center, so as to leave a groove between. Down this channel there flowed softer material, which lined the sides of the lateral ridges with a smooth coat of mud and left conspicuous flowage marks. The flow thus raised a ditch for itself above the level of the slope. The earth-flow probably assumed this form by leaving behind, at the sides, the material least capable of flowing, and by concentrating its most liquid parts along the deep central line.

The other earth-flow was near by, on the convex face of the knoll in the center of the picture. A similar cavity was produced, from which the contents were spread out broadly. It is a good example of the starting of a gully, as there was no depression before. One branch of this earth-flow came straight down the hill and slightly toward the canyon on the left; the other branch came down toward the gully in which the first-mentioned of these 2 earth-flows occurred. Thus drainage lines were started which ultimately may separate the central hill from the ridge on the right, of which it is now a continuation. The left arm of the flow on the hill may develop a channel, as explained below, which will cause the drainage from this hill, which is now toward the foreground, to pass into the canyon on the left.

Similar landslides, tho usually of smaller size, occurred thruout the region neighboring the fault visited by the writer, and even in districts at a considerable distance from the fault. Frequently they were not definitely referable to the earth-flow type, but resembled more closely earth-slumps formed without the aid of a suddenly increased water supply. It was often difficult, especially in cases where the movement was slight, or the slide was in the embryonic stage, to determine whether the earthquake at those points had caused a flow of water or not. In the instances so far described, it was pretty certain that it had; but in many others the phenomena were explainable as being the result of moisture that was already collected before the earthquake. Many slips were formed on hillsides and along the embankments of mountain roads, and along the cracks formed by the shock in moist and loosened soil. Often these slips were arranged one above another, the perpendicular faces due to slipping having the appearance of step faults. In such cases the weight of the moved mass and the amount of water was not sufficient to cause the material to flow. There were examples of such slips along the coast hills north of San Pedro Point, near the road halfway between San Bruno and San Andreas Lake, near the road from Belmont to Crystal Springs Lake, 0.5 mile southeast of the San Mateo Alms House, and in many other places on the San Francisco Peninsula. In some places bare ridges had their lines of symmetry broken into little knolls and irregularities by these slips, a common occurrence in the hills of soft sand formations in the northern part of the San Francisco Peninsula. All the slips just referred to illustrated the gradation between earth-slumps and earth-flows. Doubtless in many of them a small amount of water did gather as a result of the earthquake.

*Relation of earth-flows to rainfall* (Robert Anderson). — The rainfall previous to the earthquake, tho possibly of little importance in connection with the more extreme types of earth-flows, in which practically all the work was done by a head of water brought from underground by the shock, bears a close relation to the less extreme types, and to the geologically very important doubtful types intermediate between the earth-flows and earth-slumps. In a dry year the number and size of all of these would probably have been much less. Had covering of slopes been unsaturated, areas might not

have been so ready to break forth at a sudden accession of water from below; and the rainfall not having been great, there might not have existed such a plentiful source of underground water to be drawn from. The following review of the rainfall conditions may be of value in indicating a relation between the preparedness of the ground and the number and importance of flows and slumps.

During the first three months of 1906 the rainfall was exceptionally heavy thruout California, being on an average thruout the whole State more than 9 inches in excess of the normal for that period. Up to the beginning of 1906, the amount of rain for the season was 4.5 inches below the average; but owing to the great excess during the late winter and early spring months the total for the year up to the first of April, the month in which the earthquake occurred, was nearly 5 inches above the normal. During January, February, and March the rain was heavy and continuous. Nearly all the rain of the season was during these months immediately preceding the earthquake month. Practically no rain fell between April 1 and April 18.

All of the rainfall data available in the monthly reports of the Weather Bureau for California, compiled by Professor McAdie, has been used for calculating the amount of rain in 8 counties south of San Francisco. These are San Francisco, Alameda, San Mateo, Santa Clara, Santa Cruz, Monterey, San Luis Obispo, and Santa Barbara. The average rainfall at 46 different places distributed thru these counties was 22.59 inches from September, 1905, to April 1, 1906, between 2 and 3 inches above the normal for this region. The excess would have been greater but for the lightness of the rainfall during the autumn term, which was 3.55 inches, or several inches less than the average for former years. During the spring season up to April 1, the precipitation was excessive. During the three months that preceded the earthquake, 19.04 inches of rain fell, or 84.30 per cent of the whole precipitation up to that time. During the first half of April, there was practically no rain at all. Thruout this region, as well as thru California as a whole, March was a very rainy month; especially heavy downpours coming everywhere in the State during the last days of the month. It was the rainiest of the months except in parts of Santa Clara and Santa Cruz Counties, where more fell in the month of January.

The majority of the earth-flows and earth-slumps that occurred were near the coast, although the amount of rain that fell was not as large there as it was farther back in the mountains. The coast region, however, is subject to heavy fogs, which precipitate some moisture and help to prevent evaporation of the moisture already present. These fogs were probably a factor in causing the earth-flows and earth-slumps near the sea. The principal cases described were near Half Moon Bay. The records from Point Montara, only a few miles away, showed that the rainfall in this vicinity was heavier than at any other point along the coast south of San Francisco. During the spring season up to April 1, it amounted to 23 inches, and during the autumn season it amounted to 12 inches. The table shows that the heaviest rains wore in the Santa Cruz Mountains. At Boulder Creek, in Santa Cruz County, 55.70 inches of rain fell during January, February, and March alone, and 10 inches fell during the four months preceding.

During the spring of 1900, a large part of the precipitated moisture remained in the ground, which was previously dry, and the amount of evaporation was minimized by the continuous succession of cloudy and rainy days. The year afforded an example of the concentration of an excessive annual rainfall into a short period, with all the conditions favorable for the absorption and retention of the moisture in the ground. For this reason, conditions favored the production of debacles of various kinds in the loose material covering slopes.

The earth-flows that have been diseust are more or less similar to the flows occasioned by the bursting of peat-bogs. The causes of their origin and their nature appear to be



much the same.<sup>1</sup> Sir William Conway has given an account of a mud-avalanche,<sup>2</sup> a swift torrent of mud, water, and great rocks, in the Himalayas, somewhat similar in nature to these earth-flows. Streams and torrents of mud somewhat analogous but usually of glacial or lacustrine origin have been known to flow in the Alps. Mention of these has been made by T. G. Bonney.<sup>3</sup>

Earth-flows are important as giving rise to new drainage lines and modifying old ones. They are also powerful transporting agents. The initiation of a new drainage line is a matter of importance. Once started, it is a point of vantage for the attacks of agents of erosion, which thereupon are able to increase their work at an accelerating rate of speed. Only next in importance is the definition and fixing of embryonic depressions and gullies. Both these processes are carried out vigorously by these earth-flows, besides other processes such as the enlargement of valleys and channels already formed, the transportation of material, the destruction of the regularity of contours, and the transformation of surface rock material into a form easily removable otherwise, thus in every case supplying better leverage for further destructive action.

Earth-flows usually originate in minor depressions or in already well-formed gullies or valleys, these being the places most subject to the concentration of water; but in some instances they occur on the convex face of a slope, where the removal of soil develops a depression for the first time, and a new drainage line is made possible. The soft debris that is removed, although piled higher than the surrounding slope, lends itself easily to the formation of rivulets by the water that rises and collects in the excavation that is left. These small water-courses, once formed, control the line of flowage, and result in a sort of superimposed drainage when they have worn through the debris to the original slope below. Earth-flows of the above varieties, large and small, with the closely related types of earth-slumps, are thus among the important initial steps in the development of drainage lines in the California hills.

#### EARTH-LURCHES.

Of the three kinds of landslides thus far referred to, the first two, earth-avalanches and earth-slumps, occur quite commonly independent of earthquakes. Of the third kind, or earth-flows, the only examples that have been presented are immediately connected in genesis with the earthquake of April 18, although it is conceded that sudden accessions of water to loose earth might arise in other ways and occasion earth-flows. As regards the fourth type, the earth-lurch, it is difficult to conceive for it any other origin than an earthquake, since it is caused directly by the horizontal jerk of the ground and can not be produced in any other way. In the detailed account of the distribution of apparent intensity, a brief account of these superficial movements of the ground has been given and need not here be repeated. They are best exemplified on the flood plain of the Eel River, west and north of Ferndale; the flood plain of the Russian River; the flood plain of Alameda Creek, near Alvarado; the flood plain of Coyote River near Milpitas; the flood plain of Pajaro River; and the flood plain of the Salinas River. (Plates 136A, B and 137A, B.) In all these localities cracks were formed in the alluvium, generally parallel to the stream trench, and the ground between the cracks was caused to lurch horizontally toward the stream, usually with a rotation of the moved mass, which gave to it the profile of a Basin Range fault-block in miniature, the portion of the moved strip farther from the stream collapsing into the vacuity caused by the lurching.

<sup>1</sup> f. A. J. Cole, *Nature*, Jan. 14, 1897, vol. 55, pp. 254-256. G. H. Kinahan, *Nature*, Jan. 21, 1897, vol. 65, pp. 208-209.

<sup>2</sup> W. M. Conway, *Climbing in the Himalayas*. New York, 1894, pp. 118, 129-130, 323-324.

<sup>3</sup> T. G. Bonney, *Moraines and Mud Streams in the Alps*. *Geol. Mag.*, January, 11102, p. 8.

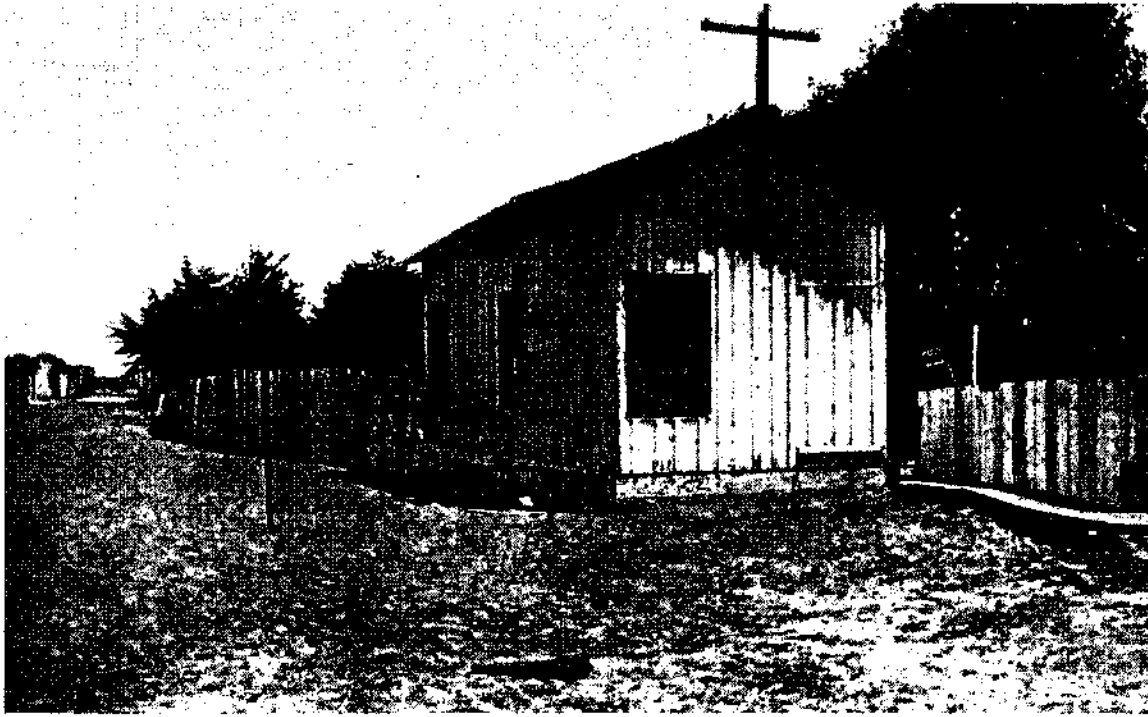

A. Moss Landing. Eonse, tree, and fence moved 12 feet by lurching of ground toward Salinas Eiver, A. 0. Li

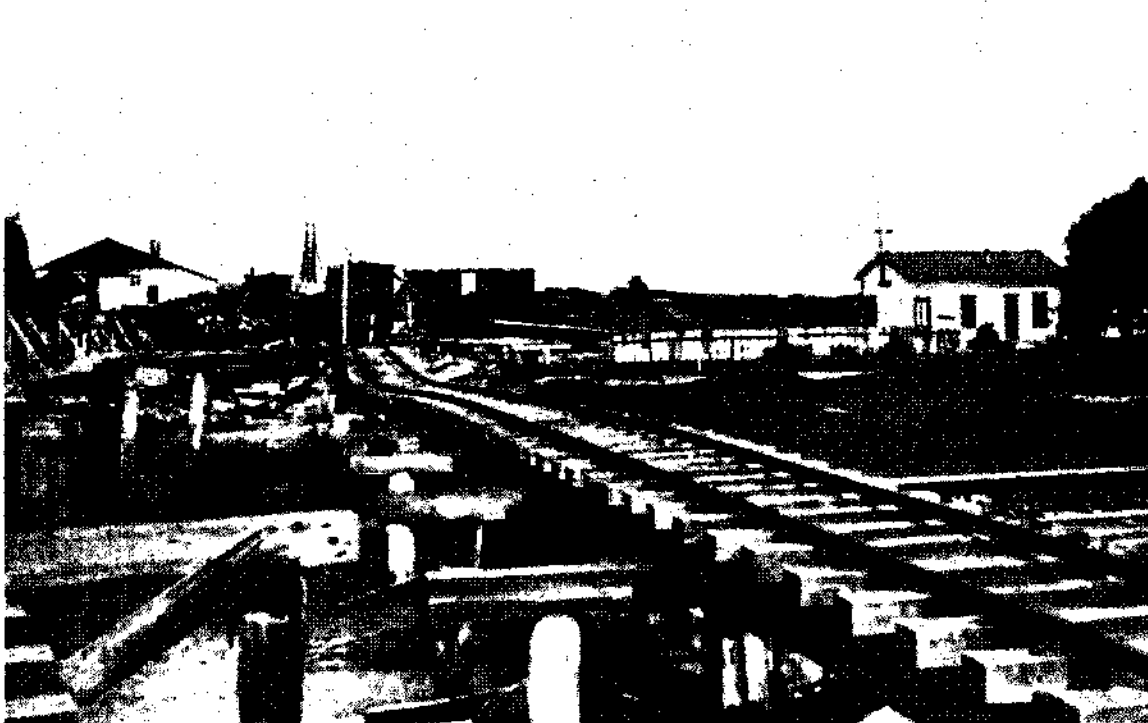

B. Mosa Laafiag. Larehiug of ground toward Saliias Eirer carried piles fros beneath Ixiige timbers, casiig it to collapse. A. 0. 1.



A. Moss Landing. Inching of ground toward Salinas Eiver, to left, carried piles from "beneath bridge timbers and caused bridge to collapse. Displacement 9 feet. A. G. L.



B. Moss Landing. Deformation of surface due to Inching of ground toward Salinas Ei?er. A. O. L.



A. Lurohing of ground toward Salinas Eiver and consequent collapse. Near Spreokelsi Ai Cd Li



B. A detail of tisw shown ia A, A. 0. I<sup>8</sup>.



A. Lowering of ground toward Salinas River, with consequent collapse. Near Spreckels. Per J. O. B.



B. Destruction of road due to subsidence of ground toward Salinas River. H. K. Brown. A. C. L.

Along the beach, or sand-spit which separates the Salinas River from the Bay of Monterey at Moss Landing, there was a marked lurching of the spit toward the trench of the river as illustrated in plates 134A<sub>7</sub> B and 135A, B.

Lurching of soft ground was also exemplified on the tidal mud flats of Tomales Bay, and on the "made land" of San Francisco; but there being no trench in these cases, the movement caused a ridging of the surface with compensating depressions. In the case of the made land in San Francisco, and perhaps generally, the deformation of the surface due to lurching was complicated by the settling together of the loose material.

#### CRACKS AND FISSURES.

The cracks in the ground which appeared at the time of the earthquake fall into different categories. Of these there are two distinct classes:

1. The crack or fissure of the main fault, which is a superficial expression of the deep rupture of the earth's crust that caused the earthquake. Associated with this as a subclass are the auxiliary cracks and fissures which are superficial expressions of branch ruptures or subparallel ruptures, generally close to the main rupture in the Rift zone. In this class would also belong any cracks due to supplementary faulting in the general zone of disturbance, if such supplementary faulting exists, which is doubtful except in special instances.

2. The second general class includes those cracks and fissures which were caused by the earthquake, as a result of the commotion of the ground, and have, therefore, been designated as secondary.

The main crack, or fault-trace, and the auxiliary cracks satellitic to it, have been described in the section of the report dealing with the earth movement along the fault.

The secondary cracks, inasmuch as they are an indication of the intensity of the shock at any locality, have been described or referred to in the section dealing with the distribution of intensity. A brief review of the phenomena of cracks in the ground, apart from the main fault-trace and the auxiliary cracks in the Rift zone, will, however, be given, even at the risk of some slight repetition.

Since some of the cracks to be referred to can not with certainty be placed in one or the other of the two fundamental classes above indicated, it will be found convenient not to force that classification in all cases. Along the zone of the Rift there were many secondary cracks, as well as those classed as auxiliary; but it was not in every case possible to discriminate between them. These secondary cracks occurred both on hill slopes and in alluvial bottoms. On the hill slopes they were very commonly associated with landslides, or marked the inception of landslides; and these have already been discuss. On the bottom lands of streams or embayments in the Rift zone, cracks in the ground were exceedingly common for the entire length of that portion of the Rift along which the fault extended. In very many cases these cracks were associated with the lurching of soft incoherent materials, just as the cracks on the hillsides were associated with more common phases of landsliding. There were also, however, many cracks quite dissociated from the deformation of the surface due to lurching, although there was doubtless in these cases an ineffective tendency to lurching.

Beyond the zone of the Rift, cracks were observed at many localities. These were most common on the bottom-lands of the streams, notably the Eel River (plate 138A, B), the Russian River (plate 139A, B), Coyote Creek (plate 140A, B), and other streams at the south end of the Bay of San Francisco, Pajaro River (plate 14In), San Lorenzo River, and the Salinas River. Many other smaller streams might also be mentioned. In these cases the cracks were usually associated with the phenomena of lurching of the alluvial deposits, though many cracks *also* occurred where no such association was apparent. They were in nearly all cases found to be parallel or sub-parallel to the nearest

portion of the stream trench. They very commonly extended for several hundred feet, in some instances for several hundred yards, and were characteristically arranged in linear series. The cracks in the series in some cases overlapt *en échelon*, and in others they were in groups of parallel cracks in belts a few hundred feet wide. In no case was there any suggestion that they were more than purely superficial phenomena. A unique manifestation of surface cracks is that described by Matthes and Crandall in the vicinity of Livermore. (See plate 141A.)

On the hillsides and ridge crests, at points not within the Rift zone, cracks were of common occurrence. Most of these were connected with landslides, as has been indicated in the section dealing with that subject. Roadways and artificial embankments were particularly susceptible to damage from such cracks. But some of the cracks had no apparent connection with landslides, actual or incipient, and these are of especial interest. The most northerly are those described by Mr. E. S. Larsen in the region northwest of Covelo, Mendocino County, as set forth in the record of intensity. Some of the cracks described by Mr. Larsen cross the crests of rocky ridges; and altho it was not possible to follow them for great distances, they evidently extend down into the rock. It is remarkable that in the district where these cracks occur, there was no evidence of a local rise in intensity and, therefore, nothing to suggest that they were the seat of a supplementary local earthquake. The probable interpretation of the occurrence is that they are secondary cracks of a rather exceptional kind, in ground that required no very severe shaking to rupture it superficially. Cracks of a similar character were noted by Mr. C. E. Weaver in the Clear Lake district and on the flanks of Mount St. Helena.

On the San Francisco Peninsula, similar cracks were observed by Mr. R. Crandall on Cahill Ridge and Sawyer's Ridge, and are described by him in his account of the distribution of intensity in that region. In the Santa Cruz Mountains, such cracks were common and are, described more or less in detail in the section on the distribution of intensity. In general they appear to be the result of the earthquake rather than a contributory cause, although in some cases it is quite possible that they may have been local ruptures of the nature of auxiliary cracks and so gave rise to subordinate vibration.

## EFFECT OF THE EARTHQUAKE UPON UNDERGROUND WATERS.

### SIGNIFICANCE OF THE PHENOMENA.

Perhaps the most interesting and significant fact which the study of the earthquake has brought to light, apart from the great fault along the Rift, was the general disturbance of underground waters. In earthquakes generally, the phenomena which appear at the surface of the earth have become well known and, indeed, almost commonplace in recent years; but what transpires in the earth's crust below the surface, as the earth-waves generated at the seat of disturbance pass through it, is as yet a matter of uncertainty and inquiry. The effect of the shock upon the movement of underground water, as manifested by the behavior of springs and wells, throws light on this question. A few pages are, therefore, devoted to recording information of this kind.

It appears from the reports that have come in that springs and wells were very generally and variably affected throughout the disturbed area, indicating a sudden derangement in the normal movements of such water. This derangement could only have been effected by the changes in spaces in the rocks in which the waters in the subsurface region are contained, whether flowing or stagnant. These spaces are of 4 general kinds: (1) interstitial spaces, or so-called voids, between the constituent fragments of imperfectly compacted rocks, such as sands, gravels, sandstones, conglomerates, tuffs,

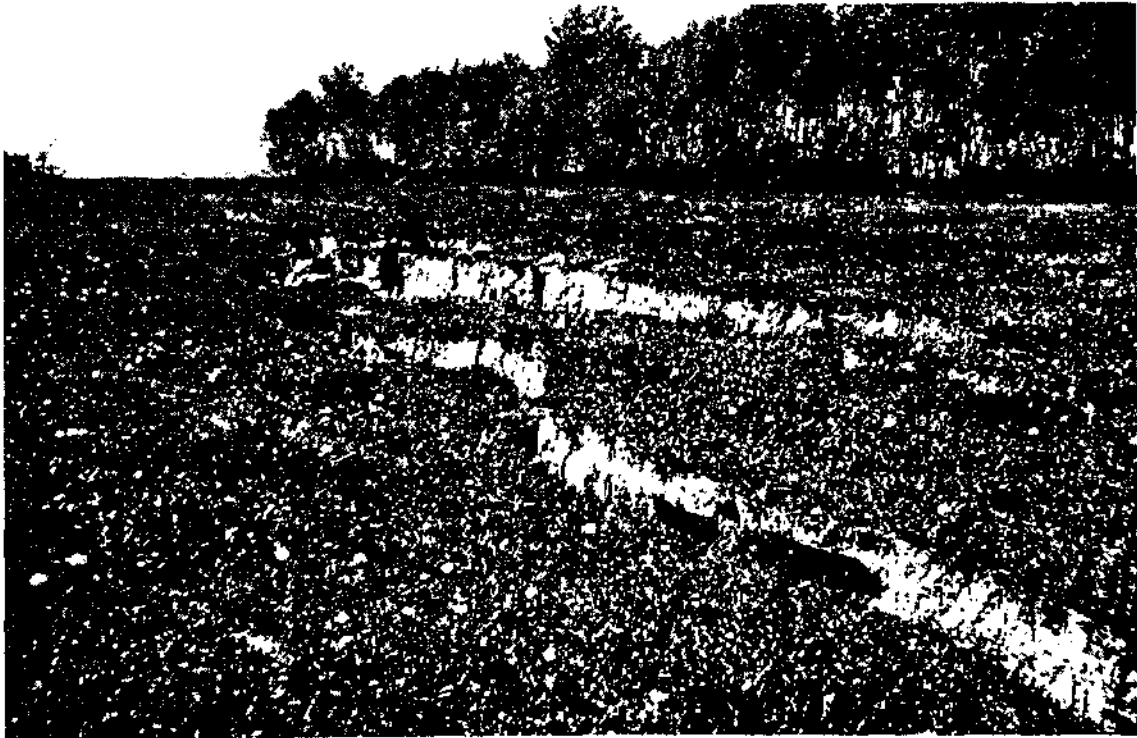

A. Eel Eiver, near Perndale, Oraolra in flood-plain, A. 8. E.



B. Eel Eivar, near Fsmdale, Orackn is led-plsla. A. 8. E.



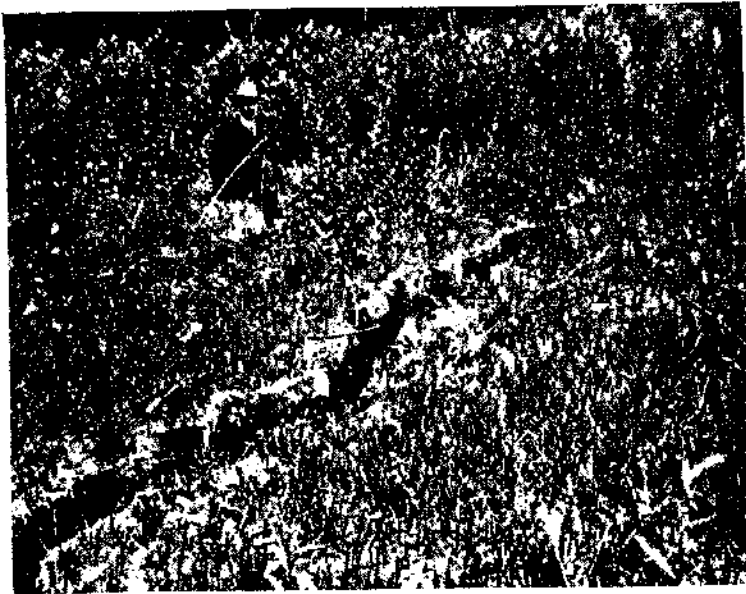

A. Russian River west of Windsor, OrackB in flood-plain. E. S. H.



B. Bnaakn Ei?er. Orack in flood-plain parallel to river. E. S. H.



C. Fisaxuea in alluvium \ Tevis raioli, near Alma. I. H. S.



D. Upheaval of bottom of artificial lake; TeviB ranch, near Alma. I. H. S.



A. Secondary cracks in alluvium near Milpitas. Per J. O. B.



B. Secondary cracks in alluvium near Cimk. Per J. O. B.



A. Oenothera plants in ground around an old alkaline spring, 1.5 miles north of Livermore. E. O.



B. Salicornia plants with dense foliage, in alkaline soil. W. A. W.

etc.; (2) the cracks and fissures which traverse the more firmly compacted forms of the same rocks, or others, such as granite, lava, etc., which occur only in a solid or coherent condition; (3) the vesicular spaces and tunnels of lavas, and (4) the spaces of dissolution which occur frequently in relatively soluble rocks, notably limestone. The occurrence of water which does not permeate the rocks nor flow thru them, but is contained in small discrete cavities in rocks, such as the liquid inclusions in igneous rocks and in the constituent minerals of sedimentary rocks, is here ignored. Thruout the Coast Ranges of California, limestones are not abundant and spaces of dissolution are believed to have played no part in the changes which were manifested in the behavior of springs and wells. The same remark holds with reference to vesicular and tunneled lavas. These changes were thus confined to the voids of porous and usually little coherent rocks and to cracks and fissures which traversed the coherent rocks, whether porous or not.

In the discussion of certain earth-flows in the preceding section of this report, the initiation of which is ascribed to a sudden accession of water from the underlying formations, attention has been already directed to an extreme phase of the disturbance of the normal conditions of the ground-water. In those cases the ground-water was suddenly expelled or squeezed out of saturated, incoherent formations at the time of the shock. They are extreme manifestations of a tendency which affected the ground water generally thruout the disturbed region. In this connection, it may be well to direct attention more particularly than has hitherto been done to the behavior of water contained in the alluvium of the river-bottoms. One of the most common phenomena in such situations was the expulsion of water in jets from apertures which suddenly appeared in the flat-lying ground. The water was usually thrown into the air for several feet; in some cases it was reported to be as much as 20 feet, and the ejection continued for several minutes after the earthquake. The continuance of the ejection after the shock indicates that an elastic stress had been generated in the saturated ground, which thus found relief in the expulsion of the contained water or that there was a gravitational settling together of the material, which diminished the spaces occupied by water. The vents thus established were very numerous, and were in many instances closely spaced; more frequently a few to the acre, and occasionally isolated. These vents were easily recognizable for weeks and even months after the earthquake, in the form of craterlets. The water in its passage to the surface brought up considerable quantities of fine sand, which, from its prevailing light bluish-gray color, was evidently derived from considerable depth. On the flood plain of the Salinas River, the sand was recognized by the people of the neighborhood to be the same as that of a stratum of sand pierced by wells at a depth of 80 feet. The craters were usually distinctly funnel-shaped and were rimmed by a circular flat ridge of sand which, by reason of its light color, was in marked contrast to the surrounding surface. They varied in diameter from 1 to perhaps 10 feet. In some instances the funnels were several feet deep; in others the feeble action in the closing stages of the eruption had caused them to fill up with sand. They were quite analogous to the craterlets described and pictured in Button's account of the Charleston earthquake.<sup>1</sup> (See plates 142A, B and 143A, B.)

These craterlets occurred on practically all the saturated alluvial bottoms of the streams within the zone of destructive effects, and also on the tidal mud flats of Tomales Bay. They are significant of the compression to which such water-laden, incoherent formations were subjected by the passage of the earth-waves at the time of the earthquake or by the consequent settling of the ground. They thus afford us, in part at least, a key to the behavior of many springs and wells. Most of the springs of the Coast Ranges are in solid rock, though they may emerge on a hillside mantled with rego-

<sup>1</sup> U. S. Geological Survey, 9th Ann. Report, pp. 296-298.

lith and soil. Such springs, as a general rule, had their flow increased at the time of the earthquake. The tendency to compression in firm rocks would not be so effective as in the case of noncoherent sediments, but it would make itself manifest in the generation of an elastic stress which would die out and merge with the normal gravitative stress very gradually. There would also be an effective tendency to bring together the walls of cracks and fissures whose planes lay transverse to the path of propagation of the compressive wave. Both of these tendencies would make for an expulsion of the water. The expulsion could not, in most cases, be effected suddenly, however, owing to the great frictional resistance; and simply resulted in an increased flow of the springs at the surface, which would continue during the life of the abnormal elastic stress. The duration of this stress appears in some cases to have lasted but a few days; in other cases it continued for 2 months, as inferred from the abnormally large flow of the springs. This variation would depend on local conditions, such as the superficial or deep source of the water, the character of the rocks, the degree to which it was seamed with cracks, etc.

This same general explanation would apply to artesian wells, in which the water acquired and maintained an increased head for some time. In some such wells, where the water stood normally at some little distance below the surface, it overflowed and flooded the ground in some instances. In other cases, where the supply was not artesian, but shallow wells reached the ground-water, the level of the latter rose. This general tendency was complicated in some instances by other effects of the earthquake. Several surface wells had their level lowered, and others went dry. This sudden drop in the level of the ground-water can be explained only by a sudden draining off of the underground waters to lower levels, and this might be effected by the opening up of the ground superficially, in consequence of the shock. A similar explanation would apply to the few springs which had their flow diminished or cut off altogether. This draining off of the waters of higher levels would also augment the flow of springs and wells at lower levels and may in some cases have been the principal cause of observed increases of flow. The noteworthy case of the spring near Ukiah, described below, which ceased flowing and remained dry thruout the following summer and fall, but resumed its flow with the advent of the winter rains, suggests that the fissure in the rock from which the spring welled served as the limb of a siphon and that the water in the siphon was drained off in consequence of the agitation and opening of the ground at the time of the shock. The winter rains refilled the siphon limb and so brought about a resumption of the flow.

One of the most common reports regarding the shallower wells was the roiling of the water by the admixture of earthy matter, doubtless due to the agitation of the ground and the loosening up of the incoherent material at the bottom of the wells.

#### RECORD OF SPRINGS AND WELLS AFFECTED.

A brief and partial record of springs and wells affected by the earthquake follows:

*Montague, Siskiyou County* (C. H. Chambers). — A sulfur spring was formed at a point 2 miles south of the town of Montague. Hot water ran from it for 2 days, after which it cooled off. A soda spring 9 miles east of the town doubled its flow. The water of many springs was muddy for several days after the quake.

*Denny, Trinity County* (P. L. Young). — At a small quartz mine near Denny the shock doubled the amount of water flowing from the tunnel.

*Peanut, Trinity County* (Mrs. E. Diller). — There was an increase in the water in the ditch which comes from a small gulch. The increased flow had not diminished up to May 6, 1906.

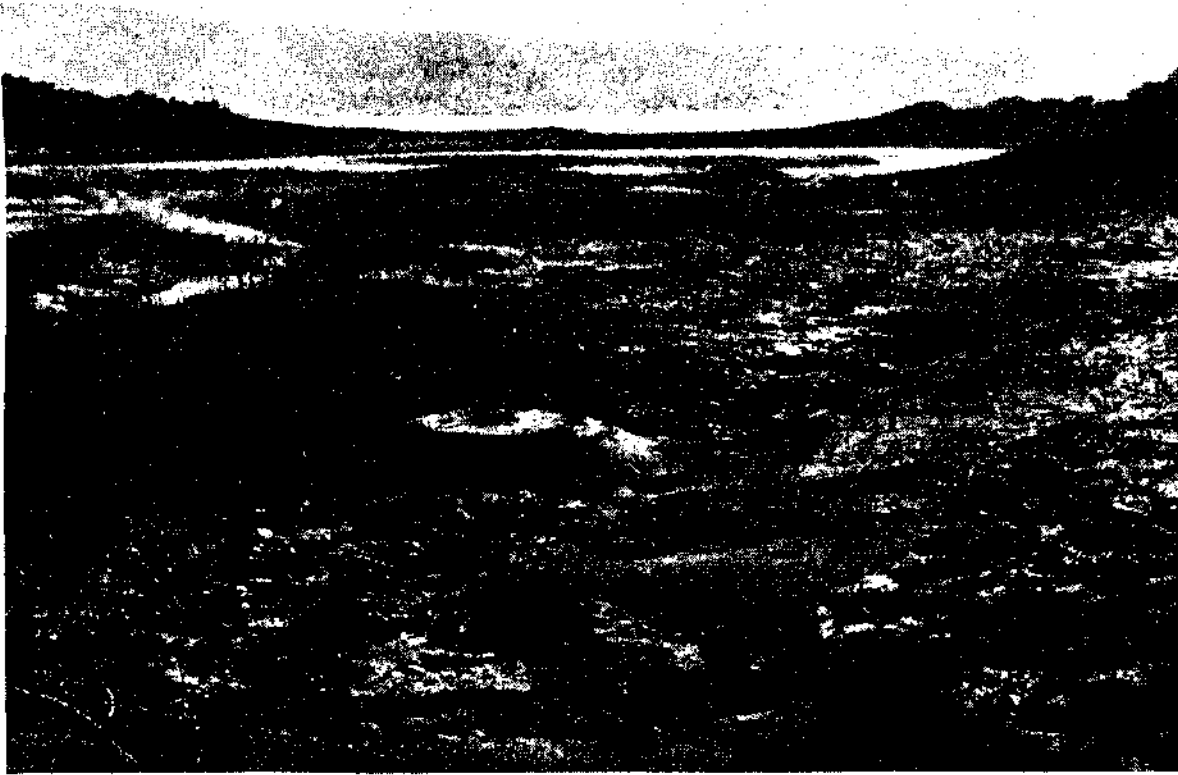

A. Oiatelets in sand near marsh east of Bodega Bay. J. N. L.



B. Oraterlets along fault-trace on sand spit at mouth of Tomales Bay. B. S. H.



A. Craterlets in fields near MilpitaB. Per J. O. B.



B. Craterlets near Watsom-fille. PerJ. C. B.

*Briceland, Humboldt County* (J. W. Bowden).—The pressure on the flow of natural gas was doubled in the vicinity.

*Covelo, Mendocino County* (E. S. Larsen).—Some springs and wells in the vicinity went dry, while others flowed more freely.

*Laytonville, Mendocino County* (A. S. Eakle).—A sulfur spring had its volume of water increased at least threefold by the shock, according to report.

*Mendocino, Mendocino County* (O. H. Ritter).—Wells in the lower part of town became full to overflowing and a heavy seepage of water was observed in the yard of the Alhambra Hotel.

(W. Mullen.)—The flow of a number of springs was increased.

*Ukiah, Mendocino County* (S. D. Townley).—The water in the well at the Observatory was very noticeably roiled for several days after the shock. The Ukiah press for April 27 reports some very marked changes in the flow of springs near Ukiah. A spring near the E. Clemens Horst Company's ranch, which supplied water for domestic and ranch purposes, stopt flowing after the earthquake. The ranch is about 2 miles north of Ukiah and a little west of the center of the valley, and the spring is in the foot-hills on the edge of the valley, nearly a mile to the west of the ranch. Pipes connected the spring with 2 tanks on the ranch, the spring having supplied the ranch with water for a great many years. The foreman, John Eldred, states that the day after the earthquake it was noticed that no water was flowing into the tanks from the spring. Investigation showed that the spring, which comes out of rock, was absolutely dry. Mr. Eldred and his men worked for two or three weeks, digging, drilling, and blasting, in the effort to regain a supply of water; but these efforts were futile and were finally abandoned. A well 75 feet deep was dug on the ranch and a wind-mill erected. Eldred went to the site of the spring several times during the summer and early fall, but there was no water. Upon going to the place in the early part of the winter, after the rains had begun, it was found that the spring was again flowing with a largely increased volume of water. He estimated that the flow was about doubled. The spring was still flowing with the increased volume on March 15, 1907.

*Hemlock, Mendocino County* (C. D. C. Bowen).—Some springs flowed more abundantly after the shock.

*Lake County* (C. E. Weaver).—At Highland Spring, in Lake County, none of the springs dried up, but one new soda spring was formed in the Franciscan rocks. The mineral springs in all parts of the county are reported to have increased in flow and number. The artesian wells in Scott's Valley, west of Lakeport, have diminished in flow, and several have stopt flowing. Many wells have dried up, but this was not confined to any particular locality or part of the county. The shock apparently had no effect upon the waters of the northern part of Clear Lake, nor upon the springs in that part of the district.

*Lakeport, Lake County* (J. Overholser).—The flow of many springs increased on account of the earthquake, while the flow of artesian wells decreased.

*Annapolis, Sonoma County* (G. W. Fiscus).—Wells and springs have gone dry in places, and water has come to the surface where there was none before.

*Sebastopol, Sonoma County* (R. M. Hathaway).—The wells in this vicinity wore all stirred up, the water becoming filled with sediment, as tho a heavy rain had washt in surface water. A small brook a little to the left of a fissure in the soil on the Blundon place had its flow of water so increased that the owner of the place had his attention called to it by the roaring of the water.

*Santa Rosa to Sonoma, Sonoma County* (E. S. Larsen).—At the city pumping station, 1.5 miles east of Santa Rosa, there are 4 wells, dug 50 feet and connected with a tunnel 450 feet long. Within each well there is a bored well 8 inches in diameter and 108 feet



deeper than the dug well. The water began to rise immediately after the shock, and is 15 feet higher than before, altho the pumps have been run to their full capacity.

The warm spring at Peters' ranch was little affected, except that for a day or so after the shock the water in the spring was lower. At Conrad ranch, northwest of Melita, there are numerous warm springs, about 100°, all along the base of a hill, which have had their flow increased very much. Mr. Striddle thinks that there is ten times as much water as before, and that it is a little warmer. He also tells me that the flow is gradually decreasing again. The springs at Melita, along the north side of the hill, have behaved much like those at Conrad's. I am told the creek about 2 miles to the north has risen considerably since the shock.

A mile north of Kenwood there is a well which was dried up about a year ago by an earthquake, and had to be dug deeper. This shock did not seem to affect it.

Glen Ellen Springs continue to be changed, usually increasing their flow, tho a few springs went dry. At McEwan's Ranch, 3 miles west, both cold and hot springs are flowing much more water. At the State Home at Eldridge, a warm spring started about 0.75 mile east of the town. Hot springs at Agua Caliente have nearly trebled their flow, and the temperature has risen from 112° to 114°. A spring which required pumping before now flows.

Boyes Hot Spring has increased a little and now flows without pumping. The temperature has also increased a little. Several years ago an earthquake stopt the flow, so that pumping has been required until this last shock. At Sonoma the wells and springs supplying the city are flowing more than before.

*Veterans' Home, Napa County* (A. Brown); — The earthquake caused the springs to flow more fully for about 2 months, after which they returned to normal.

*Napa, Napa County* (T. Hull). — In many cases springs increased their flow.

*Redding, Shasta County* (L. F. Bassett). — Some springs have been reported to have increased their flow and to have a lower temperature.

*McCloud River, Sliasta County (Chico Enterprise)*. — Springs in the limestone belt above Baird, which were formerly cold and clear, became warm and milky.

*Allegheny, Sierra County* (W. A. Clayton). — The earthquake changed the flow of water in mines and springs.

*Suisun, Solano County* (E. Dinkelspiel). — Mr. Miller's gas well, 3 miles northwest of Suisun, gave threefold greater volume of gas for 2 weeks before the earthquake than it did afterward.

*Martinez, Contra Costa County* (R. Wulzen). — Alhambra Creek is said to have risen 2 feet after the earthquake. A small stream to the east of the town, which is usually dry by May 1, now has considerable water. The same is reported of another stream south of town. A well in the vicinity, in which the water has always been several feet below the surface, is reported to be filled almost to the surface.

*Stockton, San Joaquin County* (R. Crandall). — An old disused gas well at the City and County Jail had a flow of water started in it by the earthquake. This flow continued for about two weeks, after which time it began to diminish. In a gas well, at the City and County Hospital, both the gas and water flow had been doubled and had continued so up to the time of my visit.

*Ripon, San Joaquin County* (T. H. Wren). — I have 18 acres of alfalfa land, which watered with an inch less water over the head-gate in 1905, in 17 to 20 hours. This year it took 25 hours to water 13 acres, all conditions being the same as last year except that the land was more packed and should have watered quicker. Others have made the same observation.

*Sunol, Atameda County* (R. Crandall). — The level of the ground-water around Simol was affected considerably. In most of the wells the water rose, some overflowing for

a short time. The postmaster gave 4.5 feet as the measured rise of the water in his well. The spring which furnishes the town supply is said to have been diminished by one-fourth of its flow. Two other changes in water supply were reported: one being the starting of a new spring near one of the western Pacific camps in Niles Canyon; the other the rejuvenation of an old sulfur spring near Sunol, which had not flowed for many years.

*Calaveras Valley, Santa Clara County* (G. F. Zoffman). —The springs near Mr. Robert Ingleson's house, in section 22 on the ridge east of Calaveras Valley, became muddy after the shock and remained so for two or three days. The volume of water discharged by the springs increased to about four times the usual amount.

*Alvarado* (E. W. Burr). —At the Alvarado Sugar Mill, in several wells, formerly flowing artesian wells, the water-table is now a few feet below the surface, the water-level having risen at the time of the earthquake. In the accompanying table are given the heights of water in a number of wells about the mill, referred to an assumed level 30 feet above an assumed base. These wells were observed daily before and after the earthquake. In most of them the water suddenly rose. The readings show that in a few cases the water rose from 1 to 2 feet. A well which used to be considered nearly dry began showing daily fluctuations, overflowing nearly every morning for some weeks after the earthquake.

The figures here given are for measurements made on April 9 and 14, preceding the earthquake of April 18, 1906, and the measurements made on April 21 and 28 of the same month, and May 5 subsequent thereto.<sup>1</sup>

*Heights of water referred to an assumed level 30 feet above assumed base.*

No. of Well.	Approx. Depth (feet).	April 9.	April 14.	April 21.	April 28.	May 5.
1	470	22.89	24.81	26.14	26.31	26.56
2	312	26.64	26.81	28.14	25.48*	28.23
3	318	26.22	25.47	28.05	27.97	27.30
4	402	26.62	26.87	28.37	28.20	28.28
5	405	26.67	28.17	28.34	28.25	28.42
6	402	26.70	28.28	28.37	28.03	28.45
7	399	26.79	26.87	28.45	28.04	28.45
8	45	26.79	26.87	28.45	28.04	28.45
9	544	25.36	25.36	26.69	26.94	27.19

\* No. 2, April 28. House pump was taking water from this well when measurement was taken.

*San Francisco Peninsula* (R. Anderson). —Thruout the central portion of the San Francisco Peninsula, the chief geological effects, aside from the actual displacement along the fault and the slumping and settling of alluvial ground, were the increased circulation of water and its discharge at the surface. The normal flow of water from springs was much disturbed. The water was usually muddy or milky. It is reported to have flowed salty from one spring for 2 days after the earthquake; after this it returned to its usual purity. Streams were considerably swollen temporarily, and water frequently came to the surface where it had not made its appearance before.

(R. Crarull.)—At Mr. Ebright's place, at the lower end of the lake in Pilarcitos Canyon, the spring water used for house supply is said to have been milky white the day of the earthquake. At Byrne's store, on the Half Moon Bay road, 0.5 mile west of Crystal Springs Lake, it was reported by the keeper that the water from their spring on the day of the shock was muddy and was not tasted; on the second day it had a very salty taste, and on the third day was again normal.

*Santa Clara Valley* (J. C. Brainier). —At Mcnlo Park, a mile nearer Fair Oaks Station, an artesian well flowed faster after the shock. At the Scale place, on the Embareadero

<sup>1</sup> Since the wells in this district fluctuate in level with the rise and fall of the tide in the bay, a correction would have to be made for this influence before the effect of the earthquake upon the underground water could be inferred from the figures given in the table. If the height which the level of the water in the wells was measured is known, the correction may be ascertained and applied at any time.

road, from the railway crossing at Palo Alto toward the Bay of San Francisco, a well was reopened. Other wells showed an increased flow and brought up sand. At Guth Landing, and southward along the road into Mountain View, the flow from bored wells had increased. A wind-mill which had for years pumped water from a well was no longer necessary, but the artesian water was muddy. At the Ynigo Ranch, 3 miles northeast of Mountain View Station, there was an artesian well which had, before the shock, flowed slightly or not at all, and a wind-mill was used to raise the water. After the shock it was found that the casing had been shoved up 2 feet, damaging the pump. The flow of water was increased, and black sand was brought up. Another well at this ranch was unaffected. Along the Jagel Landing road, 2 artesian wells had increased pressure after the shock. An old artesian well filled with stones had begun to flow for the first time in several years.

(H. H. Taylor.)—The water in an artesian well 215 feet in depth, near Millbrae, was roiled by the earthquake and remained so for several days.

*San Jose, Santa Clara County* (G. F. Zoffman). — Water and mud are reported to have spurted from many artesian wells.

(W. S. Prosser.)—A well near San Jose was reported as having increased in flow the day before the earthquake.

*Gilroy, Santa Clara County* (M. Connell). — It is reported on good authority that at Gilroy Hot Springs the temperature of the water rose nearly 10° and the flow increased to 5 times the usual volume.

*Bellvale, San Mateo County* (Miss L. E. Bell).—Some springs dried up and others broke out with a great gush of water, where no water had flowed before. An oil well from which tepid salt water, oil, and gas had been flowing since 1898 became suddenly dry and a similar flow began in another well 2,000 feet deep, at a distance of 600 feet to the east of the first well, where before nothing had been found.

*Wright, Santa Cruz County* (Miss F. Beecher). — Most of the springs are running with a greater flow since the earthquake; but the water in our well on top of the ridge sank rapidly to the level it usually holds in August. The water in all wells was very roily for some days.

*Summit Hotel, near Wright, Santa Cruz County* (H. R. Johnson). — The well at the summit, from which the Summit Hotel obtains its water, has its bottom on solid rock. After the shock the level of the water in the well rose 12 feet.

*Boulder, Santa Cruz County* (J. C. Branner).—At a sawmill near Boulder Creek, water stopt running from a hitherto permanent spring, but another in the neighborhood was flowing more freely than before.

*Felton, Santa Cruz County* (Miss F. Locke).—All the springs on the property of Miss S. Anderson, a mile east of Felton, greatly increased in flow.

*Soquel, Santa Cruz County* (W. E. Wheaton). — I have a drilled or bored well, yielding a magnificent flow of clear water. From three to four weeks previous to the earthquake this 75-foot well began to show signs of agitation below the surface. Every few days water heavily mixed with sand and ground chalk rock was pumped up. I knew that something was going wrong down under the earth, owing to the action of this well. When the quake came, it drove both fine and coarse sand into the casing, which put the well out of commission entirely.

*Chittenden, Santa Cruz County* (G. A. Waring). — Near Chittenden a marked increase was noted in the flow of oil and water, and more gas and sulfur appeared. In the neighborhood of Santa Ana Peak, the flow of springs was increased.

*Prunedale, Monterey County* (H. H. McIntyre). — Water started in many places where there had been little or none before the earthquake.

*Salinas, Monterey County* (G. A. Daugherty).—In many places water came up thru open fissures; in one place about 8 miles from Salinas, the water covered about 80 acres of land.

(B. M. Abbott.)—Water spouted from holes in the ground to a considerable height, and flooded the fields.

*San Ardo, Monterey County* (G. A. Waring). — At San Ardo, quicksand was thrown up in a well, seeming to lessen the flow considerably.

*Paraiso, Monterey County* (A. S. Eakle).—At Paraiso Springs, the quake affected the underground waters. According to the owner, Mrs. Romie, the supply of water from the springs had been diminishing for some time, and the temperature had been decreasing. Immediately after the shock it became necessary to put in a large pipe to carry off the water, and the temperature has resumed its normal state.

*Lonoak, Monterey County* (J. Rist). —The earthquake caused springs to flow more; and the water rose in some wells.

*San Benito Valley to San Joaquin Valley* (G. F. Zoffman). — In some places about 5 miles northwest of Bell's Station, on the Pacheco Pass road, springs were reported to be flowing 2 or 3 times as much water as they had previous to April 18. At a ranch-house 7 miles from the pass, on the east side of Pacheco Pass, the increase in the flow of water from springs in the neighborhood was said to have been noticeable. Springs were reported to have opened up considerably thruout the region around Emmet P. O.

*Stone Canyon, Monterey County* (G. F. Zoffman). — In the neighborhood of Stone Canyon Coal Mine, the people claimed that there was a sudden rise of the water of the wells immediately after the earthquake.

*Dudley, King's County* (O. D. Barton). — The gas spring on sec. 22, township 25 S., Range 18 E. was started into great activity by the earthquake. Formerly there were 7 places where gas could be seen occasionally blowing off through a shallow pool of water. Now there are more than 50 places where gas blows off continuously. The quantity of water was greatly increased. Beneath these gas springs the ground is dry and hot.

*Bakersfield, Kern County* (A. G. Grant).—Artesian wells 30 miles north of Bakersfield were rendered muddy by the earthquake.

*Gold, Madera County* (T. J. Rhodes).—Several springs increased about one-third to one-half in volume.

*Steamboat Springs, Nevada* (J. A. Reid). —At these springs the water is constantly boiling. For about 3 days after the earthquake, the volume was considerably increased, and the water became noticeably turbid with mud. On the north end of the highest sinter terrace, where heretofore the waters had been invariably clear, considerable quantities of mud were discharged. This material is now lying dry on the white surface of the sinter and is gradually being blown away. At the extreme north end of the active springs, where several mud springs have always existed, the change was noticed in the increased activity. One in particular formed a low cone of dark-colored mud, which is now dried and cracked.

RECOBI) OF AFTER-SHOCKS.

The list of after-shocks given below has been compiled by A. O. Leuschner from all reports that have come to hand. These reports include not only communications in answer to the three circulars sent out, but also other reports by interested observers. In addition many shocks in the list were taken from the separate reports printed in this volume. For the sake of completeness the shocks reported by Prof. Alex. McAdie in his monthly reports of the California Section of the Climatological Service of the Weather Bureau have also been included. A number of shocks have been inserted in the first proof from Prof. Alex. McAdie's Catalogue of Earthquakes on the Pacific Coast 1897-1906.<sup>1</sup> It should be stated, however, that this list by no means represents a complete enumeration of all after-shocks felt in California since April 18. In general, it may be said that the list becomes increasingly incomplete with the lapse of time since the great earthquake. This is particularly due to the efforts made by some of the newspapers to suppress all news regarding earthquakes in California. The list may be considered complete only for Berkeley, California, where several observers have endeavored to record every shock. As a rule the observer's name is included in the last column, initials being used for observers who have reported more than one shock. A key to the initials is given at the end of the list. The times are expressed in Pacific Standard Time.

Record of aftershocks.

Day.	Beginning of shock.	Duration.	Intensity.	Locality.	Remarks.
Apr. 18, a.m.	h. m. s.	secs.			
	S 18 57....	6 .....	IV	Berkeley.....	S. A.
	5 19.....	2.....	III	San Francisco.....	A. G. McA.; J. G. P.
	5 19 10....	.....	III	do.....	Feeble, A. G. McA.
	5 21.....	2.....	III	do.....	Feeble, A. G. McA.; J. G. P.
	5 21 54....	3 .....	III	Berkeley.....	A. G. McA.
	5 22.....	.....	III	Eureka.....	Northwest-southeast followed by a side cross-motion. Persons in beds resting east-west not awakened, A. H. B.
	5 25 54....	4 .....	III	Berkeley.....	S. A.
	5 20.....	.....	.....	San Francisco.....	Feeble, A. G. McA.
	5 27.....	2.....	III	do.....	J. O. P.
	5 28 Hi.....	2.....	II	Berkeley.....	S. A.
	5 28 19....	1 .....	II	do.....	
	5 30.....	.....	.....	Humboldt Lt. Stn.	
	5 34 40....	.....	II	Berkeley.....	S. A.
	5 35 (11)....	1.....	II	do.....	S. A.
	5 37 39....	.....	II	do.....	S. A.
	5 39 32....	.....	II	do.....	S. A.
	5 43.....	3 .....	IV	San Francisco.....	Feeble, A. G. McA.; J. G. P.
	5 43 50....	3 .....	III	Berkeley.....	Two separate jerks, S. A.
	5 48.....	.....	II	Phoenix (Ariz. I) .....	Slight. West to east.
	5 59 13....	.....	.....	do.....	S. A.
6 00.....	.....	.....	San Maten Point..		
ti (Hi).....	.....	.....	San Francisco.....	Light, N. E.	
0 10 30....	7.....	III	Berkeley.....	2 max., one at 35 s., one at 41 s., S. A.	
ti 2S 13....	2.....	II	do.....	S. A.	

<sup>1</sup> Smithsonian Miscellaneous Collections, part of vol. XLIX.

RECORD OF AFTER-SHOCKS.

Record of after-shocks — Continued.

Day.	Beginning of shock.	Duration.	Intensity.	Locality.	Remarks.
Apr. 18, a. m.	<b>h. m s.</b>	<b>secs.</b>			
	6 30.....	.....	.....	San Francisco.....	Light, N. E.
	6 30 +.....	.....	I-II	Mt. Hamilton.....	R. G. A.
	6 42.....	.....	.....	San Francisco.....	Light, N. E.
	6 44 11.....	<b>6</b> .....	II-	Berkeley.....	S. A.
	6 45.....	.....	.....	Mt. Hamilton.....	R. G. A.
	6 46 34.....	.....	II	Mt. Hamilton.....	K. B.
	6 50.....	.....	IV	Scott's Valley.....	F. L.
	6 52.....	.....	IV	do.....	F. L.
	6 56.....	.....	.....	.....	San Francisco Light, N. E.
	7 00.....	.....	.....	Cloverdale.....	Slight shock about 7 a. in.
	7 07.....	.....	IV	Scott's Valley.....	F. L.
	7 20.....	.....	.....	Sausalito.....	.....
	7 30.....	.....	IV	Scott's Valley.....	F. L.
	8.....	.....	.....	Sacramento.....	Slight shock soon after 8 a. m.
	8 02.....	<b>2</b> .....	.....	Bonita Pt. Lt. St.	Nearly vertical; toward NW.; no tremor, just a jar; 1 max. strongest at beginning; no clock stopt, no sound.
	8 07.....	.....	.....	Yerba Buena.....	Light.
	8 10.....	.....	.....	Mile Rocks.....	Smart
	8 12.....	<b>1-2</b> .....	.....	Mare Island.....	Slight shock.
	8 13.....	.....	.....	Antioch.....	.....
	8 14 14.....	<b>10</b> .....	IV-V	Berkeley.....	Was looking at watch when shock began, S. A.
	8 14 27.....	.....	IV-V	do.....	At Students' Observatory, A. O. L.
	8 14 28 <sup>h</sup> to	.....	.....	San Francisco.....	Sharp twisting motion, A. G. McA.
	8 14 33.....	.....	.....	.....	A. M. H.
	8 14 39.....	.....	II	Mt. Hamilton.....	.....
	8 14 45.....	<b>3</b> .....	.....	Sacramento.....	.....
	8 15.....	.....	.....	Alcatraz.....	.....
	8 15.....	<b>5</b> .....	.....	Oakland.....	.....
	8 15.....	.....	.....	Yountville.....	Severe.
	8 15.....	<b>1</b> .....	V	Mile Rocks.....	Strongest at middle, sound like cannon shot, following beginning 1 s. Sharp.
	8 15.....	<b>2</b> .....	V	San Francisco.....	.....
	8 18.....	<b>4</b> .....	III	do.....	.....
	8 19.....	.....	.....	do.....	N. E.
	8 19 20.....	<b>5</b> .....	V	Oakland.....	Northeast to southwest; 15 ad- ditional shocks by 1 p. in., duration 2-5 s., cast to west, III-IV. 3 shocks between 1 and 3 p.m. 5 shock- between Apr. 18, 3 p. m., and Apr. 19, 6 a. in.
	8 20.....	.....	IV	Scott's Valley.....	F. L.
	8 25.....	.....	IV	do.....	F. L.
	8 30.....	.....	II	Tuolumne.....	About X <sup>1</sup> 30" a.m.
	8 30.....	.....	.....	Stockton.....	Very light.
	8 42.....	.....	.....	San Francisco.....	N. E.
	8 55.....	.....	IV	Scott's Valley.....	F. L.
8 58.....	.....	IV	do.....	F. L.	
9 14.....	.....	.....	do.....	Sharp and short, A. G. McA.	
9 16 52.....	.....	III	San Francisco.....	K. B.; A. M. H.	
9 17.....	.....	IV	Mt. Hamilton.....	F. L.	
9 19.....	.....	IV	Scott's Valley.....	F. L.	
9 20.....	<b>1-2</b> .....	.....	do.....	.....	
9 22.....	.....	IV	Scott's Valley.....	.....	
9 26.....	.....	.....	Mare Island.....	Moderate, A. G. McA.	
9 26 10.....	<b>2</b> .....	II	San Francisco.....	S. A.	
9 28.....	<b>2</b> .....	III	Berkeley.....	.....	
9 30.....	<b>20</b> .....	.....	San Francisco.....	N.-S. Horizontal tremor 10 s. before, 1 sharp shock, nuub.	
9 30.....	.....	.....	Southampton.....	One other between 1 <sup>h</sup> 4 <sup>m</sup> and 8 <sup>h</sup> 1 <sup>m</sup> . H. G. A.	
9 30.....	.....	.....	Mt. Hamilton.....	.....	
9 32.....	<b>1</b> .....	.....	Scott's Valley.....	F. L.	
9 35.....	ISO.....	.....	do.....	F. L.	



RECORD OF AFTER-SHOCKS.

Record of after-shocks — Continued.

Day.	Beginning of shock.	Duration.	Intensity.	Locality.	Remarks.
	h. m. s.	secs.			
Apr. 18, p.m.	12 31.....	.....	III	Los Angeles.....	F. L.
	1 02.....	.....	.....	Scott's Valley.....	F. L.
	1 55.....	4.....	II	San Francisco.....	F. L.
	1 57.....	.....	.....	Scott's Valley.....	Slight. Four miles south of Wright's Station.
	2.....	.....	.....	Wright's Station..	A little before 2 p. m.
	2.....	15.....	IV	S. F. Peninsula...	Vertical throw north-south tremor 20s. before; no noise.
	2 15.....	.....	.....	Humboldt Lt. Sta.	Very light.
	2 20.....	5.....	.....	Southampton Shoal	F. L.
	2 20.....	.....	.....	Stockton.....	Slight.
	2 20.....	.....	.....	Scott's Valley.....	F. L.
	2 22.....	1-2.....	.....	Mare Island.....	Slight.
	2 23 40.....	.....	" II "	Mt. Hamilton.....	Very light, A. G. McA.
	2 24.....	.....	.....	San Francisco.....	Ewing seismograph, R. T. C. and S. E.
	2 24 37.....	.....	.....	Berkeley.....	
	2 25.....	4.....	III	San Francisco.....	
	2 25.....	.....	.....	Salinas.....	
	2 25.....	.....	.....	Los Gatos.....	I. H. S.
	2 25.....	.....	.....	Oakland.....	Alameda Pier.
	2 27.....	1-2.....	.....	Mare Island.....	Slight.
	2 28.....	.....	.....	San Francisco.....	Very light, A. G. McA.
	2 28 36.....	.....	III	Mt. Hamilton.....	A. H. M.
	2 28 50.....	.....	.....	Berkeley.....	B. L. N.
	2 29.....	.....	.....	Sacramento.....	Very light.
	2 30.....	.....	.....	Ajntioch.....	
	2 30.....	.....	IV	Scott's Valley.....	Extra hard, stopt clock hanging on wall facing south, 20" pend. Stopt clock facing NW. by WNW., pend. about 5", F. L.
	2 30.....	.....	.....	4 miles south of Wright's Station	Slight.
	2 30.....	.....	VI	Ukiah.....	Stopt clocks (counted 35 shocks up to April 30), S.D.T.
	2 30.....	4.....	III	San Francisco.....	
	2 30.....	.....	.....	Salinas.....	
	2 32.....	.....	.....	Los Gatos.....	I. H. S.
	2 35.....	5.....	III	San Francisco.....	
	2 35.....	.....	VI	Ukiah.....	
	2 35.....	.....	III-IV	Scott's Valley.....	Extra hard, F. L.
2 40.....	.....	.....	Salinas.....		
2 43.....	.....	.....	Scott's Valley.....	Lighter, F. L.	
2 50.....	.....	.....	do.....	Lighter, F. L.	
3.....	.....	V	Los Gatos.....	Little if any vertical movement. A muffled sound, like distant blasting heard in a mine, was noticed just preceding minor shocks which followed, including that about 3 p. m., I. H. S.	
4 26.....	10.....	IX-X	Raleigh.....	Three shocks.	
4 28.....	15.....	.....	Ballast Point.....	Vertical prop. SE. Increasing in intensity, strongest at middle. Clock stopt at 4 <sup>h</sup> 25 <sup>m</sup> 15 <sup>s</sup> pend, 18", facing E.	
4 28.....	.....	.....	Teinemhi.....		
4 29 45.....	20.....	IV-V	San Diego.....	Northwest and southeast. Strongest apparently at beginning. Clock not stopt, but disturbed, losing about 1 m.; pend. about 26". No sound phenomena.	
4 30.....	.....	.....	San Diego.....	Heaviest in 15 years, northeast-southwest.	
4 30.....	.....	II	Ramna.....	A few seconds.	
4 30.....	.....	III	San Bernardino...	Southeast.	



## Record of after-shocks — Continued.

Day.	Beginning of shock.	Duration.	Intensity.	Locality.	Remarks.
Apr. 15, p.m.	h. m. s.	secs.			
	4 30.....	.....	.....	San Juan Capistrano	Slight.
	4 30.....	.....	.....	Hemet, Riverside.	Shock increasing and dying away.
	4 30.....	.....	.....	Yuma (Ariz.)	9 or 10 distinct shocks, slight rolling from east to west.
	4 30.....	.....	IX	Brawley.	Northwest-southeast chimneys fell to west. Movable objects in bldgs., thrown west-east. Oscillation followed by tremors. Clock stopt at 4 <sup>m</sup> 30 <sup>m</sup> , facing south.
	4 30.....	Few ..	.....	Ballast Point.	North-south. Horizontal. Clock stopt 4 <sup>m</sup> 30 <sup>m</sup> , facing NW., pend. 17".
	4 50.....	.....	.....	Oakland	Alameda Pier.
	4 50 38.....	1.....	.....	Berkeley	Two tremors within 1 s., B.L.N.
	4 51.....	.....	.....	San Francisco	Very light, A. G. McA.
	4 52.....	.....	.....	Yerba Buena	Light.
	6 02 12.....	2.....	II	Berkeley	S. A.
	6 03 04.....	1.....	II	do.	S. A.
	6 12.....	.....	.....	Yerba Buena	Light.
	6 45.....	.....	.....	Antioch	
	6 50.....	.....	.....	San Francisco	Very light, A. G. McA.
	6 50.....	5.....	.....	Southampton Shoal	North-south. Horizon direction south, two light shocks, rumbling following shock 2 s.
	6 50.....	.....	.....	Oakland	Alameda Pier.
	6 51 29.....	8.....	IV	Berkeley	Faculty Club, S. A.
	0 51 35-45.	.....	.....	do.	Slight tremors during interval, B. L. N.
	6 51 58.....	.....	1-II	Mt. Hamilton	
	6 51 58.....	.....	II	do.	Vertical, K. B.
	6 52.....	.....	.....	Sacramento	Very light.
	6 53.....	.....	.....	Yerba Buena	Light.
	Sunset.....	.....	.....	Angel Island	Strong, rumbling.
	7.....	1-2 ..	.....	Mare Island	Slight.
	7.....	.....	.....	Stockton	Very light. Number of light shocks reported for several days, but hardly perceptible.
	7.....	.....	.....	Scott's Valley	Lighter, F. L.
	7 01.....	.....	.....	San Francisco	Very light, A. G. McA.
	7 23.....	.....	.....	Yerba Buena	Light.
	7 25.....	.....	.....	Scott's Valley	Lighter, F. L.
	9 10.....	.....	.....	do.	Lighter, F. L.
	9 43.....	.....	.....	do.	Lighter, trembling of house kept up for 2 m. or more, F. L.
	10.....	.....	.....	Lakeport	Light, about 10 o'clock.
10 38.....	.....	.....	Scott's Valley	Sharp shock, rather long. Trembling of house kept up for 2 m. or more, F. L.	
11 10.....	.....	.....	do.	Trembling of house kept up for 2 m. or more, F. L.	
11 22.....	.....	.....	do.	Light shock, F. L.	
Apr. 19, a.m.	1 30.....	.....	.....	Paisley, Oregon.	Tremor.
	3.....	20.....	.....	Eureka	Slight, A. H. B.
	3 07 00.....	.....	.....	San Francisco	Light, A. G. McA.
	5 22.....	.....	.....	Eureka	Slight and of short duration.
	5 07.....	23.....	.....	Eureka	Slight, A. H. B.
	6 25 10-1.....	3.....	III	Berkeley	Time is from memory, failed to record shock at time, S. A.
	.....	2-5 ..	11-111	Oakland	Seven shocks between 6 a. m. and 2 <sup>h</sup> 15 <sup>m</sup> p. in.
10 30.....	27.....	.....	Eureka	Slight, A. H. B.	
Apr. 19, p.m.	12 31 00.....	20-30..	.....	Los Angeles	Inm-ased intensity, 1 max., strongest at middle No sound.
	12 31 41.....	.....	.....	do.	

RECORD OF AFTER-SHOCKS.

Record of after-shocks — Continued.

Day.	Beginning of shock.	Duration.	Intensity.	Locality.	Remarks.	
Apr. 19, p. in.	h. m. a.	secs.				
	12 33	.....	.....	Los Angeles .....	Two shocks about 6 m. apart followed by slight tremors for about 1 h.	
	12 25	15.....	.....	San Pedro.....	Horizontal tremors 10 s. before, increased intensity, strongest at end. No sound.	
	1 13	.....	.....	San Francisco ....	Sharp, main portion with twist, A. G. McA.	
	2 05	.....	.....	Reno, Nevada.....		
	3 +	.....	.....	Salinas .....	Another shock later.	
	3 25	.....	.....	Sacramento .....	Seemed to be north and south.	
	8 15-8 30	.....	IV-V	Hagen, Wadsworth, etc.	On east slope of Virginia Range, Sierra Nevadas; northwest-southeast. During next 1.5 h. 3 more, G.D. L.	
	10 45	.....	.....	S. F. Peninsula...	Slight.	
	10 55	.....	.....	Laurel Glen.....	Tremor with 2 sharp after-shocks.	
	11 06	.....	.....	Yerba Buena.....	Light.	
Apr. 20, a. m.	11 10	30.....	.....	Mile Rocks.....	Slight shocks during day.	
	12 30	2.....	.....	Kureka .....	A. H. B.	
	12 30	.....	.....	Southampton Shoal	Vertical; direction upward. Tremor, 5 s. after; 2 sharp shocks, cracking sound coincident.	
	12 30 53	.....	.....	Ukiah.....	Shock too light to be felt. It was detected by motion of bubbles of latitude levels. The oscillation was \ or 1 division (N. and S.) d = 1.0", S. D. T.	
	3	3.....	.....	Eureka .....	South-north, slight.	
	4 45 00	.....	.....	San Francisco .....	Tremor, A. G. McA.	
	4 50	.....	.....	Napa .....		
	5	.....	.....	Laurel Glen .....	Short and sharp.	
	5 31	.....	.....	San Francisco.....	Moderate, A. G. McA.	
	6 10	3.....	.....	Mile Rocks .....	Moderate.	
	7	3.....	.....	do .....	Vertical. Strongest at middle.	
7 13	.....	.....	Laurel Glen .....	Short and sharp.		
7 15	.....	.....	San Francisco.....	Moderate, A. G. McA.		
11 30	.....	.....	Tuolumne .....	About 11 <sup>h</sup> 30 <sup>m</sup> a.m.		
Apr. 20, p. m.	12 33	.....	III	Santa Monica .....	North-south. Time not accurate.	
	2 30	.....	.....	Laurel Glen.....	Light.	
	5 26	10.....	IV	S. F. Peninsula...		
	5 49	3.....	III	do .....	Followed after 4 s. by another brief motion.	
	8 23	15.....	III	do .....	Series of gentle tremors.	
	8 28	.....	.....	Scott's Valley .....	Light but decided, F. L.	
	9 03	.....	.....	do .....	Barely felt, F. L.	
	10 26	.....	.....	do .....		
		.....	.....	Mile Rocks.....	Slight shocks during day.	
	Apr. 21, a. in.	3	.....	.....	Napa .....	W. H. M.
		4 4	.....	.....	Scott's Valley .....	F. L.
5 28		.....	.....	San Francisco .....	Strung, A. G. McA.	
9 05		.....	.....	Scott's Valley .....	F. L.	
1 35		7.....	IV	S. F. Peninsula.....	Shaking houses 7 s. and repeated after "> s.	
3 15		5.....	.....	Mure Island.....	T. J. J. See.	
Apr. 22, a. m.	8 27	.....	.....	Scott's Valley .....	F. L.	
		.....	.....	Mile Rocks.....	Slight shocks during day.	
	2 or 2 30	.....	.....	Felton .....		
	4 45	.....	.....	Scott's Valley .....	Two shocks; barely separated, but running fully 5 s., each a good shake, not wven. but slightly, or slightly. F. L.	

## Record of after-shocks—Continued,

Day.	Beginning of Shock.	Duration.	Intensity.	Locality.	Remarks.
Apr. 22, a. in.	h. m. s.	secs.			
	5 00.....	1.5..	.....	Mile Rocks.....	Slight.
	6 58.....	.....	.....	Scott's Valley....	Two shocks barely separated, last continuing fully 5s.; each a good shake, not severe but steady, oscillating, F. L.
	7.....	3.....	.....	Mile Rocks.....	Moderate.
	7 03 00....	.....	.....	San Francisco	Light, A. G. McA.
Apr. 22, p. m.	7 10.....	.....	.....	Scott's Valley....	A mere jolt, F. L.
	11 30.....	.....	.....	Saratoga.....	Described as underground explosion, about 11 <sup>h</sup> 30 <sup>m</sup> a. m.
	3.....	.....	.....	Napa.....	W. H. M.
	3.....	3.....	.....	Mile Rocks.....	Moderate.
	3 17.....	2.....	.....	Bonita Point.....	Nearly vertical. Direction NW.; no tremor, just a jar, 1 max., strongest at beginning. No sound, may have been blasting.
	3 18 20....	60+...	III	Berkeley.....	Tremulous motion for 5 m. after shock. Long duration of trem. motion also observed by Mr. Huber, who was in laboratory at time, weighing chemicals, S. A.
	3 18 22....	2.....	III	Oakland.....	C. B.
	3 19.....	.....	.....	Yerba Buena.....	Light.
	3 19 30....	4.....	.....	San Francisco....	Moderate rocking, about four waves, A. G. McA.
	Apr. 23, a. m.	8 35.....	.....	.....	Salinas.....
9 08.....		2.....	.....	Mile Rocks.....	Slight.
10 40.....		.....	.....	Salinas.....	
11 20.....		.....	.....	Scott's Valley....	Tremor, F. L.
12 05 00....		3.....	.....	San Francisco....	A. G. McA.
12 48.....		8.....	.....	Trinidad Head....	East-west tremor 5 s. before, short and heavy; clock stopt 12 <sup>h</sup> 48 <sup>m</sup> a. m., facing east; sound like thunder, preceded and continued during shock; same throughout, no change.
12 55.....		8.....	.....	Cape Mendocino..	Vertical. Southwest-northeast. Direction NE. increasing intensity. Clock stopt. Pend. 22", facing SW. No sound.
1 10.....		.....	.....	Grant's Pass, Ore.	
1 10.....		14.....	V-VI	Eureka.....	South-north. Stopt clocks, A. H. B.
1 11.....		10.....	.....	Ferndale.....	Severe shock, J. A. S.
1 12.....		.....	.....	Scott's Valley....	Light and short, but decided, F. L.
1 15.....		.....	II	Crescent City....	West-east.
1 16.....		.....	.....	do.....	South-north. Woke up everybody, no damage.
Apr. 23, p. m.	1 17.....	.....	.....	Cape Mendocino..	
	3.....	.....	.....	Scott's Valley....	"Just enough to waken me," F. L.
	6 07.....	4.....	.....	Eureka.....	South-north. Slight,
	6 30.....	3.....	.....	Ferndale.....	Severe shock, J. A. S.
	8 10 10....	3.....	III	Salinas.....	
	8 10 10....	3.....	III	Oakland.....	From east, C. B.
	9 15.....	4.....	.....	Mile Rocks.....	Moderate.
	12 45.....	.....	.....	Scott's Valley....	Barely perceptible, F. L.
	12 48.....	.....	.....	do.....	Very light, F. L.
	12 50.....	.....	.....	do.....	More decided, F. L.
2 50.....	30.....	.....	do.....	Decided trembling lasting perhaps 30 s., F. L.	
3 51.....	1.....	.....	San Francisco....	Sharp, downward jolt, A. G. McA.	
5 30.....	.....	.....	Salinas.....		

## Record of after-shocks—Continued.

Day.	Beginning of shock.	Duration.	Intensity.	Locality.	Remarks.
Apr. 23, p. m.	h. m. s.	secs.			
	5 45.....	3-4. ..	.....	Scott's Valley ....	Sharp, lasting 3 to 4 s., F. L.
	10 00.....	.....	III	S. F. Peninsula...	About 10 p.m.
	10 25.....	2.....	.....	Mile Rocks.....	Moderate, 2 max.
	10 34.....	.....	.....	San Francisco....	Moderate, A. G. McA.
	10 36.....	2.....	.....	Bonita Point.....	Nearly vertical. Direction NW., no tremor, just a jar, 1 max. strongest at beginning. No sound, may have been blasting.
	10 38 42....	6.....	IV	Berkeley.....	2 separate shocks, 2d stronger, S. A.?
	10 38 44....	.....	.....	do.....	2 separate shocks, 2d stronger, E. Smith.
	10 38 57?...	.....	III	do.....	Short and sharp. Northeast southwest. Tremulous mo- tion for 6 in. In bed awake, but watch correction uncer- tain, R. T. C.
	10 39.....	3.....	.....	San Francisco ....	East-west.
10 55.....	.....	II	Oakland.....	C. B.	
Apr. 24, a. m.	1 25.....	.....	.....	San Francisco ....	Short, A. G. McA.
	1 32.....	.....	.....	do.....	Tremors, A. G. McA.
	9.....	.....	.....	do.....	Doubtful, A. G. McA.
	5 46.....	.....	.....	Salinas.....	
	10 15.....	95 in. ..	.....	Berkeley.....	Slight continuous trembling, S. A.
Apr. 24, p. m.	1 14.....	.....	.....	San Francisco ....	Light throw, A. G. McA.
	4 45.....	75 m. ..	.....	Berkeley.....	Slight continuous trembling, S. A.
	8 10.....	.....	.....	Mile Rocks.....	Slight.
	10.....	60 m. ..	.....	Berkeley.....	Slight continuous trembling, S. A.
	10 45.....	.....	.....	Oakland.....	
	11 30.....	.....	.....	Berkeley.....	Reported by several. Mr. Wood also reports shock fol- lowed by unsteadiness of ground for over 1 h., S. A.
	11 42.....	.....	.....	Oakland.....	
Apr. 25, a. in.	1 26.....	3.....	.....	Berkeley.....	Light shock, lasted about 3 s. after awake, S. A.
	4 30.....	.....	.....	San Francisco ....	A. G. McA.
	6 30 22....	3.....	III	Oakland.....	Northeast to southwest, C. B.
Apr. 25, p. m.	12.....	.....	V	Mills College ....	Many small shocks.
	12 40.....	.....	III	Cloverdale.....	
	3.....	.....	.....	Mile Rocks.....	Slight.
	3.....	1.....	V-VII	Cliffs about Wood's Gulch..	
	3 12.....	2.....	V	Bonita Point....	Direction NW., no tremor, just a jar, 1 max. strongest at beginning, no sound, may have been blasting.
	3 15.....	15.....	V	S. F. Peninsula...	Strongly felt on ground, caus- ing landsliding along coast cliffs, lasting 10 s. with a slight repetition after 10 s.
	3 15.....	3.....	III	Oakland.....	C. B.
	3 15.....	.....	.....	Napa.....	Sharp, W. H. M.
	3 15.....	7.....	IV-V	Berkeley.....	Walking with Dr. King, not felt by either of us, 8. A.
	3 17.....	.....	.....	Yountville....	Undulatory twist, quite severe.
3 17 10....	.....	.....	San Francisco....	Double waves recorded on seismograph, W. It. E. and A. G. McA.	
3 17 15....	.....	.....	Oakland.....	Noticed by G. K. (J. on clock marked U. S. Observatory.	

## Record of after-shocks — Continued.

Day.	Beginning of shock.	Duration.	Intensity.	Locality.	Remarks.
Apr. 25, p. m.	h. m. s.	secs.	II-III	Mt. Hamilton	2 tremors about 5 s. apart. Time is of last one, B. L. M. Alameda Pier.
	3 17 40			Berkeley	
	3 18 20			Oakland	
	3 20			Antioch	
	3 22			Niles	
Apr. 26, a. m.	3 20			Salinas	Many shocks during month, W. B.
	10 20			Scott's Valley	
	10 23			San Jose	
	10 29			Oakland	
Apr. 26, p. m.	10 33 35		II	Mt. Hamilton	Explosion? Chabot Observatory. Jolt only, no swing, R. H. T. Slight. Like explosion under foot, similar to shock of Apr. 22 at 11 <sup>h</sup> 30 <sup>m</sup> a. m. Light, Very heavy.
	1 45	1		Mile Rocks	
	5			Saratoga	
	8			Salinas	
	8 50	4		do	
	9 38			Mile Rocks	
	9 42	2		Salinas	
	9 50	4		do	
	9 50	2		Mile Rocks	
	2			Salinas	
Apr. 27, a. m.	6 <sup>h</sup> 15	4	II	Oakland	Chabot Observatory Sharp.
	10 30	1		Ferndale	
	10 30			Eureka	
	10 30			Eureka	
Apr. 27, p. m.	1 07			San Francisco	A. G. MeA. R. T. C.
	1 09 34		II	Berkeley	
	1 10			Hollister	
	1 12			do	
Apr. 28, a. m.	10 08 10	3	III	Oakland	And many others. East to west, Chabot Observatory.
	12 35			Napa	
	5 40			Scott's Valley	
	4 55	2		Mile Rocks	
	5	2		do	
	9			Paisley, Oregon	
	11 20			Scott's Valley	
	4 08			do	
	4 09			San Francisco	
	4 09 20	1-2		Mt. Hamilton	
1 00			Oakland		
Apr. 29, p. m.	1 45	2		Mile Rocks	Vertical. Strongest at middle, sound like cannon shot, coinciding with beginning of shock. Sharp, following strongest disturbance 2 s.
	1 48	2		do	
	1 57 30			San Francisco	
	1 58 40			do	
	2 01 22		III	Berkeley	
	7 10			San Francisco	
	7 20			Oakland	
Apr. 31, a. m.	1 45	2		Mile Rocks	snght.
	1 48	2		do	
	1 57 30			San Francisco	
	1 58 40			do	
Apr. 31, a. m.	2 01 22		III	Berkeley	Single swing, A. G. MeA. Northeast-southwest. Short and sharp, R. T. C.
	7 10			San Francisco	
	7 20			Oakland	
	7 10			San Francisco	
	7 20			Oakland	
	7 10			San Francisco	
	7 20			Oakland	
	7 10			San Francisco	
	7 20			Oakland	
	7 10			San Francisco	
7 20			Oakland		

RECORD OF AFTER-SHOCKS.

Record of after-shocks — Continued.

Day.	Beginning of shock.	Duration.	Intensity.	Locality.	Remarks.
Apr. 30, p.m.	h. m. s.	secs.			
	1 05.....	2.....	.....	Mile Rocks.....	Vertical. Strongest at end.
	10 50.....	.....	.....	Scott's Valley.....	Barely perceptible, F. L.
	10 58.....	.....	.....	Cape Mendocino.....	Southwest. Vertical. Direction south, very light.
	11 10.....	.....	.....	Eureka.....	Slight.
May 1, a. m.	6 05.....	2.....	.....	Mile Rocks.....	Slight.
	9 21.....	.....	.....	Cloverdale.....	
May 1, p.m.	9 19.....	15.....	.....	Healdsburg.....	Very smart shock, perceptible roaring, oscillatory.
	9 30.....	.....	.....	Guerneville.....	Articles thrown from north to south. Cracked much plaster.
	9 45.....	I 1-4.....	.....	Mile Rocks.....	Slight.
	9 57 55.....	.....	.....	Berkeley.....	A. O. L.
	9 58.....	.....	.....	do.....	Faculty Club, G. K. G.
	9 58 24.....	12.....	III	do.....	East-west. Several max. Had watch out in 3 s., slight shaking 30 s. more, S. A.
	.....	.....	.....	Napa.....	No time given. Three light shocks during day, W. H. M.
	.....	.....	.....	Peachland.....	No time given.
May 2, a. m.	I 12 36.....	I.....	.....	Napa.....	Sharp, W. H. M.
	4 05.....	.....	.....	Los Gatos.....	I. H. S.
	6 51 30.....	.....	.....	San Francisco.....	Very light, A. G. McA.
	6 56 20.....	.....	II	Oakland.....	Chabot Observatory.
	8 50.....	.....	.....	San Francisco.....	Very light, A. G. McA.
May 2, p.m.	4 51 13.....	.....	11	Mt. Hamilton.....	C. D. P.
	4 53.....	.....	.....	Santa Cruz.....	Lively shake.
	9 22.....	.....	.....	Calistoga.....	
	9 58.....	.....	.....	S. F. Peninsula.....	
	10 53.....	.....	.....	Scott's Valley.....	Two vibrations apparently from SE., F. L.
	.....	.....	.....	Laurel.....	No time given.
May 3, a.m.	1-3.....	.....	.....	Glenwood.....	12 quakes, each preceded by sounds.
	5 56.....	5.....	.....	Scott's Valley.....	Reported as 6 a.m. in Santa Cruz. Strong vibrations east-west. Sleepers generally awakened, F. L.
	G.....	I.....	.....	Santa Cruz.....	
	6.....	.....	.....	Point Pinos.....	Short.
	6.....	.....	.....	Los Gatos.....	Vertical, I. H. S.
	6.....	.....	.....	San Francisco.....	Very light, A. G. MeA.
	6 20.....	.....	.....	Oakland.....	Chabot Observatory.
	9 41 22.....	.....	.....	San Francisco.....	Very light, A. G. McA.
May 3, p.m.	4 17.....	.....	.....	Los Gatos.....	I. H. S.
May 4, a.m.	j 12 05.....	.....	.....	Scott's Valley.....	" Wakened me," F. L.
	I 5.....	.....	.....	Point Pinos.....	
	5 25.....	5.....	II	Mt. Hamilton.....	Two distinct principal shocks, 0.5 s. apart, 3 s. after beginning. North to south. No sound. No vertical motion, J. D. M.
	5 28.....	.....	.....	Los Gatos.....	I. H. S.
	5 32.....	.....	.....	Sun Francisco.....	Very light, A. G. McA.
	(5.....	12.....	.....	Scott's Valley.....	Two people at least were? awakened. Three shocks almost continuous, not severe.
	H 30.....	5.....	.....	do.....	Very slight trembling for perhaps 5 s., F. L.
	10 29 30.....	.....	.....	Sun Frum-isco.....	Sharp jar, A. G. MeA.
	10 40.....	.....	.....	Los Gatos.....	I. H. S.
	.....	.....	.....	Campbell.....	No time given.

## Record of after-shocks—Continued.

Day.	Beginning of shock.	Duration.	Intensity.	Locality.	Remarks.
May 5, a. m.	h. in. s.	secs.			
	10 15.....	3.....	.....	Mile Rocks.....	Moderate.
	10 28.....	.....	.....	Oakland.....	Chabot Observatory.
	10 29 30.....	.....	.....	San Francisco.....	A. G. McA.
	10 29 43.....	.....	.....	Berkeley.....	Northwest-southeast. Single displacement to northwest, with return to southeast, B. L. N.
	10 29 45 + 2	.....	II	do.....	J. N. LeC.
	10 30.....	.....	IV	S. F. Peninsula...	
	10 30.....	.....	.....	Napa.....	W. H. M.
	10 30.....	.....	.....	Oakland.....	Alameda Pier.
	10 30 05...	1.....	.....	Mt. Hamilton.....	W. W. O.
May 5, p. m.	11 45.....	1.....	.....	Mile Rocks.....	Slight.
May 6, a. m.	.. ..	.....	.....	San Francisco .....	Several tremors during early morning.
	3 05.....	.....	.....	Los Gatos.....	Rotary motion north-south. Vertical, I. H. S.
	7 29.....	.....	.....	San Francisco.....	Light, A. G. McA.
	8 40.....	1.....	.....	Mile Rocks.....	Slight.
	8 59 20.....	.....	.....	San Francisco.....	Strong. Last one double wave. Felt like a push. Then more waves, A. G. McA.
	8.....	.....	.....	Bartlett Springs..	
	8 10.....	10.....	VII	Upper Lake.....	Very violent, almost due east, sudden.
	8 12 34....	25.....	III-IV	Ukiah.....	Direction west-east, increasing intensity. No max. No noise. Watch compared immediately; times probably not in error more than 2 s., S. D. T.
	8 17.....	.....	.....	do.....	
	8 32.....	.....	.....	do.....	
9 +.....	5.....	VII	Upper Lake.....	Very violent, many clocks stopt, I. H. S.	
9 +.....	.....	.....	Los Gatos.....		
9 45.....	1.....	.....	Mile Rocks.....		
11 15.....	1.....	.....	do.....		
11 25.....	.....	.....	Los Gatos.....	Rotary, I. H. S.	
.. ..	.....	.....	Blocksburg.....	No time given.	
May 7, a. m.	.. ..	.....	.....	San Francisco.....	Several tremors during night. About 3 a. in.
3.....	.....	.....	Point Pinos.....		
3 20.....	1.....	.....	Mile Rocks.....		
3 45.....	.....	.....	do.....		
5 07.....	.....	.....	San Francisco.....	Very light, several light tremors during night and early morning, A. G. McA.	
May 7, p. m.	4 10.....	.....	.....	Los Gatos.....	Rotary, I. H. S.
4 17 10....	.....	.....	San Francisco.....	Sharp jar, A. G. McA.	
4 30.....	.....	.....	Bartlett Springs..		
May 8, a. m.	4 30.....	.....	.....	Los Gatos.....	I. H. S.
10 16.....	.....	.....	Yerba Buena.....	Light.	
May 8, p. m.	12 12.....	.....	.....	San Francisco.....	Light, A. G. McA.
11 40.....	.....	.....	Campbell.....		
11 40.....	.....	.....	Los Gatos.....	North-south, I. H. S.	
11 40.....	.....	.....	Point Pinos.....	Indefinite as to a. m. or p. m.	
11 42.....	.....	.....	San Francisco.....	Sharp jar, A. G. McA.	
11 42 02....	10.....	II-III	Palo Alto.....	No max. No noise. Also felt by Prof. L. M. Hoskins, but no time taken. Watch compared with standard clock at Ukiah at 10 p. m., May 8, and at 11 a. in., May 9. S. D. Townley.	

Record of after-shocks — Continued.

Day.	Beginning of shock.	Duration.	Intensity.	Locality.	Remarks.
	h. m. s.	secs.			
May 8, p.m.	.....	.....	.....	Salinas .....	No time given.
May 9, a.m.	.5 20.....	.....	.....	San Francisco .....	Light, A. G. McA.
	5 44 13.....	.....	.....	Palo Alto.....	Just one jolt. Not felt by Prof. Hoskins; absolutely certain it was quake, S. D. T.
May 9, p.m.	2 .....	.....	.....	Saratoga .....	About 2 p. m. Like explosion under foot.
	7 25.....	.....	.....	Eureka.....	South-north. Several seconds. Shook windows.
	9 30.....	3.....	.....	Ferndale .....	J. A. S.
	10 30.....	.....	.....	Salinas.....	
	.....	.....	.....	Los Gatos.....	Two light shnc-ks, I. H. S,
May 10, a.m.	12 15.....	.....	.....	San Francisco .....	Light, A. G. McA.
	6 47.....	.....	.....	Blocksburg .....	
	6 55.....	3.....	.....	Ferndale .....	J. A. S.
	6 59.....	4.....	.....	Eureka.....	Slight sudden jolt. South to north.
	10 45.....	.....	.....	Blocksburg.....	One light shock.
	.....	.....	.....	Los Gatos.....	One light shock, I. E. S.
	.....	.....	.....	Laurel.....	No time given.
	.....	.....	.....	Montague.....	No time given.
May 11, p.m.	1 10.....	2.....	.....	Mile Rocks.....	Slight.
	1 27 46.....	.....	.....	Oakland.....	Chabot Observatory.
	1 27 50.....	25".....	.....	Bolinas.....	
	1 30.....	.....	.....	Napa.....	W. H. M.
	1 30.....	2.....	.....	Bonita Point.....	Nearly vertical. Prop. NW. No tremor, just a jar. 1 max., strongest at beginning. Rumbling coincident with shake. May have been blasting.
	1 30 49.....	3.....	.....	San Francisco.....	Heavy, A. G. McA.
	1 40.....	.....	.....	Salinas.....	
	1 40 4±10.....	.....	11 +	Berkeley.....	Residence 1820 Walnut St.
	1 45.....	.....	.....	Kentfield.....	
	.....	.....	.....	Los Gatos.....	One light shock. No time given, I. H. S.
	3 30.....	.....	.....	Napa.....	W. H. M.
May 12, a.m.	4 00.....	.....	.....	do.....	North-south.
May 13, p.m.	7 50.....	.....	.....	do.....	North-south.
May 14, p.m.	5 19.....	.....	V	S. F. Peninsula...	Caused ground in tremble distinctly, and brought down broken plaster.
	5 21.....	.....	.....	San Francisco.....	Sharp jar, A. G. McA.
	9.....	.....	.....	Campbell.....	
	9.....	.....	.....	Los Gatos.....	North-south, I. II. S.
	9 03.....	.....	.....	San Francisco.....	Light, A. G. McA.
May 15, a.m.	12 30.....	.....	.....	Berkeley.....	G. K. G.
	1 10.....	.....	.....	do.....	G. K. G.
	2 20.....	.....	.....	Point Pinos.....	Vertical.
	9 20.....	.....	.....	Mile Rocks.....	Moderate.
	11 53.....	.....	.....	Los Gatos.....	I. H. S.
	11 56 47.....	5.....	II-III	Mt. Hamilton.....	Ending with jolt, Mrs. R. G. A.
May 15, p.m.	4 20.....	.....	.....	Los Gatos.....	I. H. S.
	.....	.....	.....	Campbell.....	No time given.
May 16, a.m.	5 20.....	3.....	.....	Ferndale.....	I. J. A. S.
May 16, p.m.	11.....	.....	.....	Heber.....	
	11 30.....	.....	.....	Berkeley.....	G. K. G.
	.....	.....	.....	Salinas.....	No time given.



## Record of after-shocks—Continued.

Day.	Beginning of shock.	Duration.	Intensity.	Locality.	Remarks.
May 17, a.m.	h. m. s. During night 12 18 .....	secs. .....	VI	Imperial .....	Two slight shocks.
	12 30 .....	.....		S. F. Peninsula...	One of the severest since the first shock, woke all sleeper's, swayed houses, set dogs barking.
	12 35 .....	.....		Berkeley .....	G. K. G.
	11 05 45 .....	.....		Los Gatos .....	I. H. S.
May 17, p.m.	3 40 .....	.....	San Francisco .....	Light, A. G. McA.	
	8 15 .....	35 .....	Ferndale .....	Two more before 6 a.m., J. A. S.	
	8 17 .....	.....	Mile Rocks .....	Vertical. Strongest in middle.	
	8 17 .....	.....	Oakland .....	Alameda Pier.	
	8 17 .....	.....	Los Gatos .....	Short, but with considerable vertical motion, I. H. S.	
	8 20 .....	.....	Salinas .....		
	8 20 .....	2 .....	Bonita Point .....	Nearly vertical. Direction N., no tremor, just a jar, 1 max., strongest at beginning. No sound, may have been blasting.	
	8 20 .....	22 .....	Point Pinos .....	Horizontal. Two max. alike, sound like water in pipe with air in it.	
	8 20 .....	.....	Oakland .....	Chabot Observatory.	
	8 21 .....	20 .....	VI	S. F. Peninsula...	About the heaviest since first shock, causing people to rush out-of-doors.
	8 21 .....	.....	.....	Napa .....	W. H. M.
	8 21 .....	.....	.....	Gonzales .....	
	8 21 .....	.....	.....	Campbell .....	Violent.
	8 21 17 .....	12 .....	IV-V	Oakland .....	Chandelier swung with period of 1.25 s. Shock NW.-SE. at Vernon St., R. T. C.
	8 21 22 .....	14 .....	IV	Mt. Hamilton .....	Vertical slightly, 2 max. 5 s. and 10 s. after beginning, mean of two observers, W. W. C.
	8 21 34 .....	8 .....	.....	Berkeley .....	East-west, A. O. L.
8 21 40 .....	8 .....	III	Bolinas .....	S. A.	
8 22 .....	.....	.....	Yerba Buena .....	Light.	
8 22 25 .....	.....	.....	Berkeley .....	Faculty Club, G. K. G.	
8 24 30 .....	.....	.....	San Francisco .....	Moderate rolling motion, A. G. McA.	
8 24 33 .....	.....	.....	Oakdale .....	Very slight. No time given.	
8 30 .....	2 .....	.....	Southampton Shoal .....	Southeast-northwest. Rumbling before shake and continuing 2 s. after.	
.....	.....	.....	Livermore .....	No time given.	
.....	.....	.....	San Luis Qbispo .....	No time given.	
May 18, a.m.	12 22 .....	.....	Berkeley .....	G. K. G.	
	1 45 .....	.....	do .....	G. K. G.	
	5 29 .....	.....	Los Gatos .....	I. H. S.	
May 18, p.m.	7 56 .....	.....	San Francisco .....	Light, A. G. McA.	
	8 30 .....	2 .....	Los Gatos .....	I. H. S.	
	8 37 .....	3 .....	II-III	Ope Mondocino... Ukiah .....	Southwest. Vertical. Direction S. Very light. No max. No sound. Watch compared immediately and clock correction determined within an hour, S. D. T.
	8 37 .....	2 .....	.....	Ferndale .....	J. A. S.
	8 37 .....	.....	.....	Fort Bragg .....	
	8 37 .....	.....	.....	Blocksburg .....	
May 18, a.m.	10 37 .....	.....	Los Gatos .....	I. H. S.	
	10 37 .....	.....	do .....	Slight.	
	10 37 .....	.....	Campbell .....		
May 18, a.m.	10 37 .....	.....	Los Gatos .....	East-west. Vertical, I. H. S.	

Record of after-shocks — Continued.

Day.	Beginning of shock.	Duration.	Intensity.	Locality.	Remarks.
May 19, a.m.	h. m. s.	secs.	II-III	Mt. Hamilton..... do..... Ferndale..... Los Gatos.....	East-west, W. W. C. Very slight shock, J. A. S. I. H. S.
	2 32 10.....	.....			
	3 30.....	.....			
	4 47.....	.....			
May 19, p.m.	11 30.....	.....	.....	do..... Fort Bragg..... Blinckeburg.....	No time given.
	2 30.....	.....			
	11 56.....	.....			
May 20, a.m.	2 35.....	.....	.....	Carson City.....	Light. West-east, C. W. F.
May 20, p.m.	9 05.....	.....	.....	Fort Bragg..... Los Gatos.....	I. H. S.
	11 00.....	.....			
May 21, a.m.	5 30.....	3.....	.....	Mile Rocks.....	Moderate.
May 21, p.m.	2 00.....	.....	III	Los Gatos..... S. F. Peninsula..... do.....	I. H. S.
	4 50.....	.....			
	12 00.....	.....			
May 22, a.m.	.....	.....	.....	Los Gatos..... Ferndale.....	No time given, I. H. S. Before daylight. Very slight, J. A. S.
	.....	.....			
May 22, p.m.	12 30.....	.....	.....	Bartlett Springs..	"The tremor might have been due to thunder."
May 23, a.m.	5 30.....	.....	.....	Los Gatos.....	<b>I. H. S.</b>
May 24, a.m.	1 30.....	.....	.....	do.....	<b>I. H. S.</b>
May 24, p.m.	1 28.....	.....	.....	do..... do..... Bonita Point.....	<b>I. H. S.</b> <b>r. H. S.</b> Nearly vertical. Direction NE. No tremor, just a jar. 1 max. strongest at begin- ning. Sound like clap of thunder 2 s. before. May have been blasting.
	S 45.....	.....			
	11 17.....	2.....			
May 25, a.m.	12 58.....	45-50	.....	Berkeley.....	At Faculty Club. First irregular, then rhythmic and slow, then more rapid. During rhythmic part was able to recognize a distinctly east-west direction, and thought this changed later to north-south, but not quite sure, G. K. G.
May 25, p.m.	10 21.....	&.....	.....	do.....	Began with confused irregular motion, but middle and final portions definitely rhythmic I tried without use of watch to estimate period of rhythm, and think it was between 2 and 5 beats of the second, G. K. G.
May 27, it. in.	Early.....	.....	.....	Lo < GuU*..... Santa Cruz.....	I. H. S. Slight shock.
May 28, a in.	1 00.....	.....	.....	Los Gatos..... < >..... do.....	I. H. S. I. H. S. S. H. S.
	1 4.....	.....			
	4 Of.....	.....			
May 28, p in.	10 47.....	.....	.....	Santa Cruz.....	
May 30, p in.	11 27 20.....	.....	.....	Saint Francis-ro.....	Light. A. G. McA.
May 31, a HI	Early.....	.....	.....	Los Gatos.....	<b>I. H. S.</b>

## Record of after-shocks — Continued.

Day.	Beginning of shock.	Duration.	Intensity.	Locality.	Remarks.
May 31, a.m.	h. m. s.	<b>secs.</b>			
	5 45.....	.....	.....	Napa .....	W. H.M.
	5 49 54....	.....	.....	Berkeley.....	R. T. C. in bed. Short and sharp.
	5 50.....	.....	.....	San Francisco___	Light, A. G. McA.
June 3, a.m.	8 25.....	.....	.....	Los Gatos .....	I. H. S.
	9 17.....	.....	.....	do.....	
June 4, p.m.	9 40.....	.....	.....	Ferndale .....	Very slight, J. A. S.
	11 40.....	2.....	.....	Mile Rocks .....	
	11 50.....	.....	.....	Los Gatos .....	Rotary, I. H. S.
	11 50.....	.....	.....	Campbell.....	Sharp.
	11 50 50....	3.....	III	Oakland.....	Chabot Observatory. South-west to northeast,
	11 51.....	.....	.....	Mills College.....	
	11 51 07....	60 +...	IV-V	Berkeley.....	Ewing seismograph.
	11 51 45....	.....	.....	do.....	A. O. L.
	11 52.....	.....	.....	San Francisco___	A. G. McA.
	11 55.....	.....	.....	Napa .....	No time given.
June 5, a.m.	9 50.....	.....	.....	Los Gatos .....	I. H. S.
June 5, p.m.	11 55.....	.....	.....	Niles .....	
June 7, a.m.	12 21 39....	.....	.....	Berkeley.....	A. O. L.
	.....	.....	.....	Eureka.....	No time given.
	.....	.....	.....	Upper Mattole___	Heavy. No time given.
June 7, p.m.	4 10.....	.....	.....	Blocksburg .....	
	4 13.....	15.....	.....	Ferndale.....	Slight, J. A. S.
	4 15.....	.....	.....	Fort Bragg .....	
	4 15.....	26.....	.....	Eureka .....	South of west to east. Sudden, increasing, then dying. Shook buildings. Severest since April 18, A. H. B.
June 8, a.m.	5 15.....	.....	.....	Fort Ross .....	
	9.....	.....	.....	do.....	
June 8, p.m.	6 15.....	1.....	.....	Mile Rocks.....	Slight.
June 9, a.m.	11 35.....	.....	.....	Fort Ross .....	
	11 56.....	.....	.....	do.....	
June 9, p.m.	7 40.....	.....	.....	Mills College.....	A. G. McA.
	7 41.....	.....	.....	San Francisco....	
June 10, p.m.	.....	.....	.....	Eureka.....	No time given.
	4 00.....	.....	.....	Los Gatos .....	I. H. S.
	6 26.....	2.....	.....	Ferndale.....	Slight shock, J. A. S.
	9 41.....	.....	.....	San Francisco___	
June 11, a.m.	.....	.....	.....	Napa .....	No time given.
	4 30 Ship's time	10.....	.....	Coronel Bay, South America .....	S.S. Assuan. Sharp shock.
June 12, p.m.	2±.....	.....	.....	Los Gatos .....	
June 13, a.m.	11 50.....	.....	.....	Eureka.....	Very light shock.
	.....	.....	.....	Tequisquita Ranch	No time given.
	.....	.....	.....	Campbell.....	No time given.
	11 51.....	.....	.....	Ferndale.....	Very light, J. A. S.
June 14, a.m.	4 50.....	.....	.....	do.....	Very light, J. A. S.
June 14, p.m.	5 55.....	.....	.....	Los Gatos.....	

Record of after-shocks — Continued.

Day.	Beginning of shock.	Duration.	Intensity.	Locality.	Remarks.
June 14, p.m.	h. m. s. 5 56..... 11 35.....	secs. ..... .....	..... .....	Los Gatos..... do.....	
June 15, a.m.	3 40..... 6 11 50....	..... .....	..... .....	Fort Bragg..... Mt. Hamilton....	E. S.
June 15, p.m.	12 05..... 12 09..... 9 20..... 9 25..... 9 39 35....	..... ..... ..... <b>5</b> ..... .....	..... ..... ..... .....	Los Gatos..... do..... Sonoma..... Mile Rocks..... Berkeley.....	Moderate. Omori seismograph, east-west. Component $79 \pm 10$ ; north-south component $76 \pm 10$ . Chabot. Observatory. From northeast.
	9 39 45....	<b>3</b> ....	III	Oakland.....	
	9 40..... 9 40 52....	..... .....	..... II	Sonoma..... Berkeley.....	East-west 2 shocks, 1 & apart, A. O. L. A. G. McA.
	9 41..... 9 41..... 9 41..... 9 41 52.... 9 42..... 9 45..... 9 51 39.... <b>10 30</b> ..... <b>10 32 64!</b> ....	..... ..... ..... ..... ..... ..... ..... 2..... 12.....	..... ..... ..... ..... ..... ..... <b>I</b> ..... .....	San Francisco..... Los Gatos..... Mills College..... Berkeley..... Niles..... Livermore..... Berkeley..... Mile Rocks..... Berkeley.....	R. T. O. W. B. A. O. L. Slight. Omori seismograph, east-west component. Omori seismograph, north-south component. A. G. McA. No time given. No time given. Three shocks reported, W. H. M.
	10 35.....	17.....	.....	do.....	
	10 35.....	.....	.....	San Francisco..... Peachland..... Napa.....	
June 16, a.m.	9 15..... .....	..... .....	..... .....	Los Gatos..... Peachland.....	T. H. S. No time given.
June 16, p.m.	4 50..... 11 50.....	..... .....	..... .....	Ferndale..... do.....	Light, J. A. S. Light, J. A. S.
June 18, a.m.	.....	.....	.....	Fort Ross.....	No time given.
June 20, a.m.	8 10.....	.....	.....	Ferndale.....	Very light, J. A. S.
June 22, a.m.	6 07..... ..... .....	..... ..... .....	..... ..... .....	San Francisco..... Kentfield..... Mt. Tamalpais.....	A. G. McA. No time given. No time given.
June 22, p.m.	11 40..... 11 51 10....	<b>4</b> ..... <b>8</b> .....	..... <b>II-III</b>	Mile Rocks..... Berkeley.....	Slight. Principally vortical. Slight tremors for 5 m. afterwards, no rumble, R. T. C.
	11 51 03....	<b>24</b> .....	.....	do.....	I Omori seismograph, east-west component.
		<b>24</b> .....	.....	do.....	I Omori seismograph, north-south component.
June 25, a.m.	9 16.....	<b>6</b> .....	.....	Ferndale.....	Light, J. A. S.
June 26	..... .....	..... .....	..... .....	Napa..... Peachland.....	No time given. No time given.
June 27	.....	.....	.....	Fort Ross.....	No time given.
June 28	.....	.....	.....	Peachland.....	No time given.
June 30	.....	.....	I	Upper Mattole.....	No time given. About the one hundredth shock since April 18. W. H. Rose.

## Record of after-shocks — Continued.

Day.	Beginning of shock.	Duration.	Intensity.	Locality.	Remarks.
July 1	h. m. s. .....	secs. .....	.....	Mt. Tamalpais___	No time given.
July 2	5 45.....	.....	.....	Fort Bragg.....	a.m. or p.m. not given.
July 4, a.m.	5 35..... 5 39..... 5 45..... 5 45.....	..... ..... ..... .....	I	Los Gatos..... Mt. Hamilton..... Campbell..... Salinas.....	I. H. S. East-west, E. A. F.
July 4, p.m.	1 15..... 1 15..... 10 45.....	..... ..... .....	.....	San Francisco..... Los Gatos..... do.....	A. G. McA. I. H. S. I. H. S.
July 6, a.m.	10 32.....	1.....	.....	Mt. Hamilton___	Two light shocks. Three vibrations, R. G. A.
July 6, p.m.	10 52..... 10 52 15 ± 2	..... 19S..	.....	Salinas..... Berkeley.....	Omori seismograph, east-west component. (North-south dismantled.)
	10 55..... 10 58.....	..... .....	.....	Mt. Hamilton___ Los Banos..... San Luis Obispo..	Light. East to west, R. G. A. No time given.
July 7, a.m.	4.....	.....	.....	Berkeley.....	Uninterrupted trembling until 6 a.m., R. T. C. and H. F. R.
July 9, p.m.	10 00..... 11 30..... 11 37..... 11 40.....	..... ..... ..... .....	.....	Eureka..... Los Gatos..... Eureka..... Ferndale.....	Rotary. Vertical, I. H. S. Very light, J. A. S.
July 12, a.m.	..... 5 38?.....	..... .....	.....	Mt. Tamalpais.... San Francisco.....	No time given. A. G. McA.
July 13, a.m.	5 20..... 5 30..... 5 35.....	..... ..... .....	.....	Sierra Madre____ Los Angeles..... Newhall.....	Moderate, U. S. W. B.
July 16, a.m.	12 10.....	.....	.....	Los Gatos.....	Northwest-southeast, I. H. S.
July 17, p.m.	3.....	3.....	IV	Palo Alto.....	About 3 p.m.
July 18, a.m.	3 10.....	.....	.....	Los Gatos.....	I. H. S.
July 18, p.m.	6 27 35.....	.....	.....	San Francisco.....	A. G. McA.
July 20, a.m.	1 00..... 1 19 36..... 1 19 42 ± 2	4..... 35.3... .....	..... III	Mile Rocks..... Berkeley..... do.....	Slight. Omori seismograph, north-south component. Omori seismograph, east-west component.
	1 20..... "i 20.....	..... .....	.....	do..... Mt. Tamalpais___ San Francisco.....	Sudden jerk apparently from east-west with tremor lasting 3 to 4 s. Awakened from sound sleep, A. O. L. Sharp shock. Dr. J. E. M. No time given. A. G. McA.
July 21, p.m.	10 10.....	.....	.....	Los Gatos.....	North-south. Vertical, I. H. S.
	.....	.....	.....	San Luis Obis-po..	No time given.
July 22, a.m.	9 16.....	.....	.....	S5mi.N.S0°W.from Cape Mendocino	Slight shock reported by Capt. J. R. Sarrins of schooner <i>Espada</i> in Lat. N. 40° 3', Long. W. 128° 15'.

Record of after-shocks — Continued.

Day.	Beginning of shock.	Duration.	Intensity.	Locality.	Remarks.
	h. m. s.	secs.			
July 22, a.m.	9 30.....	6.....	.....	85 mi. N. 86° W. from Cape Mendocino	Lat. N. 40° 33', Long. W. 126° 15'.
July 22, p.m.	10 39 30____ 11 48 20____	60 ±	II	San Jose .....	Horizontal, H. F. R.
July 23, a.m.	5 41..... 11 25.....	.....	II	San Jose .....	Horizontal and vertical motion, H. F. R.
	.....	.....	.....	Los Gatos .....	H. F. R.
	.....	.....	.....	Mt. Tamalpais....	I. H. S.
July 23, p.m.	12 10..... 11..... 4 12.....	.....	.....	Los Gatos .....	No time given.
	.....	.....	.....	Helen Mine.....	I. H. S.
	.....	.....	.....	Los Gatos .....	I. H. S.
July 24, p.m.	6.....	.....	.....	Imperial .....	
July 25, p.m.	11 04 30 ±	60 ±	II	San Jose .....	H. F. R.
July 26, a.m.	4 37 30 ±	30 ±	II	do.....	H. F. R.
July 26, p.m.	9 18 30.... .. .. . 9 20.....	34..... 19.....	.....	Berkeley .....	Omori seismograph, east-west component.
	.....	.....	.....	do. (Same record.)	Omori seismograph, north-south component.
	.....	.....	.....	Mills College.....	
July 27, p.m.	10 10.....	.....	.....	Point Loma .....	
July 28, a.m.	12 22 40.... 5 25..... 5 44..... 6 01..... 7 25..... 7 46.....	40.....	II II II II II	Berkeley..... do..... do..... do..... do..... do.....	H. F. R. H. F. R. H. F. R. H. F. R. H. F. R. H. F. R.
	.....	.....	.....	Mt. Tamalpais....	No time given.
July 29, a.m.	6 46.....	20.....	II	Berkeley .....	H. F. R.
July 30, a.m.	5 35.....	.....	II	do.....	H. F. R.
	.....	.....	.....	Eureka.....	No time given.
Aug. 1, a.m.	6..... 11 31..... 11 32.....	..... ..... 2.....	.....	Peaehland..... Ferndale..... Eureka..... San Luis Obispo..	Light. Very light, J. A. S. Vibration from southwest. No time given.
Aug. 2, a.m.	6 04..... 0 10:..... 6 14-15.... 6 15 ± 5m.	..... ..... ..... .....	.....	Fort Ross..... Plantation..... do..... Berkeley.....	G. W. C. Hard. Rumbling noise from ocean for 2 days. Slight. Omori seismograph. Duration, east-west component 2 m. 48 ± 10 s. Duration, north-south component 1 m. 36 ± 10 p.
Aug. 3, p.m.	5..... 5 03..... 7 05..... 7 10..... Between 8 and 12... 11.....	..... ..... 40..... 15.....	.....	Plantation..... Fort Ross..... Gulf of California do..... do..... Plantation.....	Heavy, f< dlowedbvslight shock. G. W. C. * Lut. N. 25° 35', Long. 110° 06' W. Ship Alex Gibson. Very heavy shock. Lighter shock. Two more shocks, very light.
Aug. 4, ft.m.	5 39.....	.....	I	Mt Hamilton.....	Heavy.

## Record of aftershocks — Continued.

Day.	Beginning of shock.	Duration.	Intensity.	Locality.	Remarks.
	h. m. s.	secs.			
Aug. 4, p.m.	11 19.....	.....	II	Berkeley.....	Faculty Club, slight vibrations, H. F. R.
Aug. 5, a.m.	1 50..... 1 53.....	..... .....	..... II	Fort Ross..... Berkeley.....	G. W. C. Faculty Club, slight vibrations, H. F. R.
	3 25.....	.....	II	do .....	Faculty Club, slight vibrations, H. F. R.
	6 15.....	.....	II	do .....	Faculty Club, slight vibrations, H. F. R.
Aug. 6, a.m.	10 32 2.....	.....	II	Mt. Hamilton ....	
Aug. 8, p.m.	5 56-57m.. 6 13.....	..... .....	..... .....	Los Gatos .....	I. H. S.
				do .....	<i>i.R. a.</i>
Aug. 12, a.m.	6 00.....	.....	.....	Rio Vista .....	
Aug. 14, a.m.	8 30..... 9 35.....	..... .....	..... .....	Salinas..... do .....	Light. Light.
Aug 15, a.m.	2 07 15.... 4 40 .....	25..... .....	..... .....	Berkeley..... Tequisquita Rancho	Omori seismograph in east- west component.
Aug. 16, p.m.	4 17 58.... 7 45 ship's time	..... 3 m. . .	..... .....	Berkeley..... Coronel Bay, S, America .....	Omori seismograph. Duration 1 <sup>h</sup> 40 <sup>m</sup> . SS. <i>Rameses</i> .
Aug. 19, a.m.	1 59..... 2 .....	..... .....	..... .....	Salinas .....	Sharp.
	9 .....	.....	.....	Tequisquita Rancho San Francisco	Tremor and jolt, A. G. MeA.
Aug. 21, p.m.	12 15.....	1 m. . .	.....	Lat. N. 26° 19'... Long. 110° 25'....	Gulf of California. Heavy. Bark <i>St. James</i> .
Aug. 22, a.m.	1 55.....	.....	.....	Napa .....	W. H. M.
Aug. 25, p.m.	1 40.....	.....	.....	Ferndale.....	Light shock, J. A. S.
Aug. 26, p.m.	9 09.....	3.....	.....	do .....	Light shock, J. A. S.
Aug. 27, a.m.	10 .....	.....	.....	Point Loma.....	
Aug. 28, a.m.	3 .....	.....	.....	Forndale.....	J. A. S.
	11 40.....	.....	.....	Tequisquita Rancho	
Aug. 29, a.m.	7 59 35....	2.....	.....	Mt. Tamalpais ...	Southeast-northwest, W. W. Thomas.
Aug. 30, a.m.	2 12.....	.....	.....	Sonoma.....	
Aug. 31, a.m.	3 12..... 9 52.....	..... .....	..... .....	do .....	
				Fort Ross.....	
Sept. 1, a.m.	3 12..... 5 50.....	..... .....	..... .....	Sonoma .....	Light shock.
				Tequisquita Rancho	
Sept. 2, a.m.	3 45..... 3 55.....	1 m. . . .....	..... .....	Lat. N. 43° 40'.. Long. W. 128° 50' Lat. N. 43° 40'.. Long. W. 128° 50'	Bark <i>Agate</i> . Heavy. 100 miles west of Coos Bay. Not so severe.
S <sup>^</sup> pt. 6, a.m.	12 10.....	.....	.....	Branscomb.....	A. J. Haun.
Sept. 7, a.m.	6 37..... 9 24 59.... 9 30.....	5-10.. 10 .....	..... II-III	San Francisco____ Mt. Hamilton____ Santa Cruz.....	Very faint, G. K. G. Perceptible vibration. One slight shock. East to west.

RECORD OF AFTER-SHOCKS.

429

Record of after-shocks—Continued.

Day.	Beginning of shock.	Duration.	Intensity.	Locality.	Remarks.
Sept. 8, p.m.	h. m. s. 12 32.....	secs. 20-30.	.....	Berkeley.....	Faculty Club. To and fro motion with period of about 0.5 s., but closed with irregular fluttering motion, G. K. G.
Sept. 9, a.m.	4 15..... 4 55..... 4 55..... 5..... 5.....	.....	.....	Grass Valley..... Carson City..... Pilot Creek..... Nevada City..... Wabuska, Nev.....	Southeast-northwest, J. Sanks. C. W. F. E. W. Stanton. S. W. Marsh. Tremor, J. G. Young.
Sept. 13, a.m.	11.....	.....	.....	Lat. N. 43° 02'... Long. W. 125° 41'	Bark <i>Palmyra</i> , 48 miles W. of Cape Orford.
Sept. 13, p.m.	8 45.....	.....	.....	Ferndale.....	Short, J. A. S.
Sept. 14, a.m.	8 46.....	44 m. . .	.....	Berkeley.....	Omori seismograph, east-west component (origin probably 435 mi. distant).
	.. .. .	25.....	.....	Lat. N. 41° 78'... Long. W. 125° 52'	85 mi. NW. Cape Mendocino. (No time.) Schooner <i>Robert Searle</i> .
Sept. 16, a.m.	7 12 2.....	.....	III?	Mt. Hamilton.....	Several observers give north to south. Duplex showed E. 20° S.
Sept. 17, p.m.	5 15..... 8 10.....	10.....	.....	Ferndale.....	J. A. S. J. A. S.
Sept. 18, p.m.	8 45.....	.....	.....	do.....	J. A. S.
Sept. 20, p.m.	2 20..... 11 39.....	.....	.....	do..... Mare Island.....	From 20° W. of S. movem't   s. Faculty Club. Slight, G. K. G.
Sept. 21, p.m.	11 24.....	.....	.....	Berkeley.....	Faculty Club. Slight, G. K. G.
Sept. 25, a.m.	5 36.....	.....	.....	do.....	Faculty Club. Slight, G. K. G.
Sept. 25-26	.. .. .	.....	.....	do.....	From 5° W. of H. movement   s. (No time.)
Oct. 5, a.m.	6 30.....	.....	.....	Mare Island.....	
Oct. 7, p.m.	11 57.....	.....	.....	San Francisco.....	G. W. C.
Oct. 10, a.m.	5 45.....	.....	.....	Fort Ross.....	
Oct. 10, p.m.	11 45.....	.....	.....	Tequisquita Rancho	
Oct. 11, a.m.	5 30.....	.....	.....	San Francisco.....	
Oct. 15, p.m.	2 49.....	.....	.....	Salinas.....	Omori seismograph.
Oct. 17	.. .. .	.....	.....	Berkeley.....	During night, G. W. C.
Oct. 18, a.m.	5.....	.....	.....	Fort Ross.....	
Oct 24, a.m.	8 45 10....	.....	.....	Tequisquita Rancho	Omori seismograph.
Nov. 4, a.m.	11 58.....	.....	.....	Berkeley.....	
Nov. 6.	.. .. .	2-3....	.....	Fort Rosa.....	No time given. Sharp, followed by 3 mountainous waves 55 mi. W. of Cape Disappointment Schooner <i>Stanley</i> .
Nov. 7	.....	.....	.....	Eureka.....	No time given.



## Record of after-shocks—Continued.

Day.	Beginning of shock.	Duration.	Intensity.	Locality.	Remarks.
Nov. 9, a.m.	h. m. s. 2 .....	secs. .....	.....	Fort Bragg.....	
Nov. 11, a.m.	6 40 ship's time	.....	.....	Lat. N. 42° 51'... Long. W. 127° 51'	Ship received a quick rolling motion, and a few seconds after trembled fore and aft. Bark <i>Carondelet</i> .
Nov. 12, a.m.	.....	.....	.....	Salinas .....	Light.
Nov. 13, a.m.	.....	.....	.....	Fort Bragg.....	
Nov. 13, p.m.	7 47 49... 7 48..... 7 48..... 7 48.....	..... ..... ..... 3.....	..... ..... ..... .....	Mt. Hamilton .... Glenwood..... Tequisquita Rancho San Jose".....	One jolt. North to south. Sharp. East to west.
Nov. 14, a.m.	2 30.....	.....	.....	Fort Bragg.....	
Nov. 14-15	.....	.....	.....	Fort Ross .....	During night.
Nov. 16, a.m.	12 30.....	.....	.....	Berkeley.....	Short tremor, G. K. G.
Nov. 22, p.m.	3 53..... 10 45.....	..... .....	..... .....	Glenwood .....	Isabella.....
Nov. 25, p.m.	1 15.....	.....	.....	San Francisco....	Very light.
Nov. 26, a.m.	.....	.....	.....	do.....	No time given,
Nov. 26, p.m.	10 27.....	8-10..	.....	Lat. N. 14° 41'... Long. W. 92° 36'	Sharp shock. About 20 mi. off coast of Guatemala. S.S. <i>Newport</i> .
Dec. 2, a.m.	1 19..... 2 23.....	..... .....	..... .....	Berkeley .....	do.....
Dec. 6, a.m.	6 45.....	.....	.....	Tequisquita Rancho San Luis Obispo..	First stronger, G. K. G. Increasing in strength, with regular horizontal oscillation with period estimated at about 0.5 s. Became irregular toward end, giving sense of fluttering, but superposed on the irregular motion was a regular beat with an estimated period of 1 s., G. K. G. No time.
Dec. 7, p.m.	10 55.....	.....	.....	San Miguel.....	
Dec. 8, a.m.	10 40.....	.....	.....	Idyllwild .....	
Dec. 8, p.m.	5 48 54.....	2.....	.....	Mt. Tamalpais___	Light shock.
Dec. 9, a.m.	3 20..... 4 20..... 3 20..... 3 20 40....	..... ..... 20..... 6.....	..... ..... ..... .....	San Francisco___ Mills College..... Berkeley..... Oakland.....	Duration a few seconds. One marked wave southwest to huethea;*, A. G. MeA. J. Keep. Southwest-northeast. Light, C. B.
Dec 19, ]»ssJ	2 40..... 3.....	..... .....	..... .....	Esconditlo .....	Cuyainieu.....
Dec. 22, u m.	S 4">.....	.....	.....	Culexio.....	
Dw. IW, u HI.	4..... 4 55..... 5 48..... 9 26 35.....	..... ..... ..... .....	..... ..... ..... .....	Cuytuuea..... Culexio..... Fort IW..... Berkeley.....	Onmri seismograph, east-west cuinpuient only.

Record of aftershocks — Continued.

Day.	Beginning of shock.	Duration.	Intensity.	Locality.	Remarks.
Dec. 24, a.m.	h. m. s. 2 .....	secs. .....	.....	Napa .....	Sharp jar.
Dec. 25, p.m.	8 15..... 8 18.....	.....	.....	Rohnerville .....	
				Eureka.....	
Dec. 28, a.m.	.. .. .	.....	.....	Lytle Creek .....	In the early morning. Light.
1907.					
Jan., 1 p.m.	11 00.....	.....	.....	Kentfield .....	
Jan. 4, a.m.	3 20.....	.....	.....	Santa Cruz.....	Regular rocking motion. First north-south, F. L.
Jan. 5, p.m.	5 to 6.....	.....	.....	Fort Ross.....	
Jan. 6, a. in.	3 15.....	.....	.....	Salinas.....	
Jan. 7, p.m.	9 20..... 10 48 55..... 11 03..... 11 05.....	..... ..... ..... 4.....	..... ..... ..... .....	Idyllwild..... Berkeley..... do .....	Oniori seismograph. G. K. G. First shock, then short, ominous lull, followed by quick vicious shaking and twisting, which lasted not more than 4 s. Seemed to come from north-west, F. L.
	11 05.....	.....	.....	Campbell .....	Sharp, No damage.
	11 05.....	.....	.....	Niles .....	
	11 05.....	.....	.....	Salinas .....	
	11 10.....	.....	.....	Los Gatos .....	I. H. S.
	11 10.....	.....	.....	San Francisco .....	
	11 20.....	.....	.....	Glenwood .....	
	.. .. .	.....	.....	Boulder Creek....	Hour not given.
Jan. 8, p.m.	3 45..... 4 31 36.....	..... 10.....	VI .....	Santa Cruz .....	Sharp jolt, F. L.
				Berkeley.....	Omori seismograph, east-west component only.
Jan. 9, p.m.	12 39 42....	101.....	.....	do.....	Omori seismograph, north-south component only.
Jan. 10, p.m.	3 21.....	.....	.....	Idyllwild .....	
Jan. 13, a.m.	4 50.....	.....	.....	Blocksburg .....	
Jan. 14, a.m.	4 50.....	.....	.....	Eureka .....	Light.
Jan. 14, p.m.	4 23 35.....	.....	.....	Berkeley .....	Omori seismograph, north-south component only. Duration 18 in. 15 s.
Jan. 18, p.m.	11 45.....	.....	.....	Idyllwild .....	
Jan. 19, a.m.	7 05..... 9 36 00..... 9 35 45.....	..... 24..... 23.....	..... ..... .....	Isabella .....	Light.
				Berkeley.....	Omori seismograph, north-south component.
				Berkeley.....	Omori seismograph, east-west component.
Jan. 23, a.m.	10 53.....	7.....	.....	do.....	Omori seismograph, east-west and north-south components.
Jan. 25, a.m.	9 25 38..... HI :B Art..... lo r,t; 12.....	90..... 60..... 133.....	..... ..... .....	do..... do..... Berkeley.....*	Omori seismograph, north-south component only. Omori seismograph, north-south component only. Omori seismograph, north-south component only.
					Mjulli röjupjient (>nly.

## Record of aftershocks — Continued.

Day.	Beginning of shock.	Duration.	Intensity.	Locality.	Remarks.
Jan. 25, p.m.	h. in. s.	<i>secs.</i>			
	3 24 18. ....	.....	.....	Berkeley.....	Omori seismograph, north-south component.
	3 24 18. ....	.....	.....	do.....	Omori seismograph, east-west component.
	3 57 18. ....	.....	.....	do.....	Omori seismograph, east-west and north-south components.
Jan. 26, a.m.	10 13 47....	27.....	.....	do.....	Omori seismograph, north-south component.
	10 14 08....	10.....	.....	do.....	Omori seismograph, east-west component.
	10 24 49....	<b>30</b> .....	.....	do.....	Omori seismograph, north-south component only.
Jan. 28, p.m.	2 42 18....	39.....	.....	do.....	Omori seismograph, north-south component only.
	4 16 54....	.....	.....	do.....	Omori seismograph, north-south component. Slight irregular shifts.
	4 18 44....	.....	.....	do.....	Omori seismograph, east-west component.
Jan. 29, p.m.	5 00 32....	.....	.....	do.....	Omori seismograph, north-south component.
	5 00 32....	.....	.....	do.....	Omori seismograph, east-west component.
Jan. 30, p.m.	2 .....	.....	.....	Kentfield.....	
	2 41 11:....	.....	.....	Berkeley.....	Omori seismograph, Both components.
	<b>3</b> .....	.....	.....	San Francisco___	
Jan. 31, a.m.,	12 30.....	.....	.....	Kentfield.....	
	0 27.....	.....	.....	Mills College.....	
	12 30.....	.....	.....	Sonoma.....	Light.
	12 30 18....	64.....	.....	Berkeley.....	Omori seismograph, north-south component.
	12 30 32....	86.....	.....	do.....	Omori seismograph, east-west component.
	12 33.....	.....	.....	Niles.....	
	12 33.....	.....	.....	San Francisco___	
	12 35.....	.....	.....	San Jose.....	Sharp.
	12 35.....	.....	.....	Napa.....	
	12 36 06....	.....	III	Berkeley.....	Awoke people in my house, R. T. C.
.....	.....	.....	Boulder Creek___	No hour given.	
Feb. 3, a.m.	10 30.....	<b>8</b> .....	.....	Lat. N. 37° 35'....	Neither shock was violent, but a decided trembling motion east-west, 28 geo. mi. S. 73° W. from SB. Farallon, Schooner <i>Melrose</i> .
	10 50.....	<b>5</b> .....	.....	Long. W. 123° 35'	
Feb. 3, p.m.	7 55.....	.....	.....	Livermore.....	
Feb. 5, a.m.	4 25.....	.....	.....	La Porte.....	
Feb. 13, a.m.	<b>10 50</b> .....	.....	.....	Livermore.....	
Feb. 14, a.m.	6 45.....	.....	.....	do.....	
Feb. 16, a.m.	2 09 30....	.....	.....	Point Loma.....	
Feb. 25, a.m.	5 16 40....	.....	.....	Eureka.....	

*Record of after-shocks—Continued.*

Day.	Beginning of shock.	Duration.	Intensity.	Locality.	Remarks.
Mar. 11, p.m.	h. m. s. 11 58.....	secs. 20....	.....	Berkeley.....	Faculty Club. In bed at time, 3 phases. First more than one-half total time, rapid tremor. Period averaging less than 0.25 s. Second about one-half total time. Higher intensity. Motion less irregular, period estimated at 0.5 s. Third, comparatively short. Motion irregular. Average period shorter than second phase. Intensity at first same as second phase, but rapidly declined, G. K. G.
Mar. 24, a.m.	5 56 04....	.....	.....	do.....	Omori seismograph, north-south component.
	5 56 06....	.....	.....	do.....	Omori seismograph, east-west component.
Mar. 30, p.m.	2 28 22....	17..	.....	do.....	Omori, north-south component.
	2 28 22___	9..	.....	do.....	Omori, east-west component.
Apr. 14, p.m.	10 40.0....	21 0..	.....	do.....	Omori, north-south component.
	10 32.2m....	37 2..	.....	do.....	Omori, east-west component.
May 12, a.m.	10 21 31___	26..	.....	do.....	Omori, north-south component.
	10 21 31___	24..	.....	do.....	Omori, east-west component.
June 5, a.m.	12 26 37....	03..	.....	do.....	Omori, north-south component.
	12 26 37....	53..	.....	do.....	Omori, east-west component.
	12 26 36....	35..	IV-V	do.....	Observatory, R. T. C.
	12 26 41....	.....	.....	do.....	Observatory, S. E.
June 10, a.m.	9 47 51....	1 47..	.....	do.....	Omori, north-south component.
	9 47 51....	2 32..	.....	do.....	Omori, east-west component.
	9 47 55....	.....	.....	do.....	At Faculty Club, S. E.
	9 48 05....	30..	.....	do.....	At home. Asleep, A. O. L.
	9 47 47....	.....	III	do.....	2011 Bancroft Way, R. T. C.
	11 10 48___	.....	.....	do.....	Omori. (Doubtful shock.)

KEY TO INITIALS.

R. G. A. = R. G. Aitken  
 S. A. = S. Albrecht  
 W. B. = William Barry  
 A. H. B. = A. H. Bell  
 C. B. = Charles Burkhalter  
 K. B. = K. Burns  
 G. W. C. = G. W. Call  
 W. W. C. = W. W. Campbell  
 R. T. C. = R. T. Crawford  
 N. E. = Nelson Eekart

W. R. E. = W. R. Eekart  
 S. E. = S. Einarson  
 E. A. F. = E. A. Fath  
 C. W. F. = C. W. Friend  
 G. K. G. = G. K. Gilbert  
 A. M. H. = Adelaide M. Hobe  
 J. N. LeC. = J. N. LeConte  
 A. O. L. = A. O. Leuschner  
 F. L. = Finette Locke  
 J. D. M. = James D. Maddrill

W. H. M. = W. H. Martin  
 A. G. McA. = A. G. McAdie  
 B. L. N. = Burt L. Newkirk  
 C. D. P. = C. D. Perrine  
 J. G. P. = J. G. Plummer  
 H. F. R. = H. F. Reid  
 J. A. S. = J. A. Shaw  
 B. S. = E. Smith  
 I. H. S. = Irving H. Sayder  
 S. D. T. = S. D. Townley

## COMPARISON WITH OTHER SEVERE EARTHQUAKES IN THE SAME REGION.

---

### THE EARTHQUAKE OF 1868.

The earthquake of October 21, 1868, was most severely felt in the region about San Francisco Bay, particularly on the east side in the vicinity of Haywards. The time of its occurrence is variously stated from 7<sup>h</sup> 47<sup>ra</sup> to 7<sup>h</sup> 54<sup>m</sup> A. M. It gave rise to disasters in the city of San Francisco, and some people recalling the event vividly are of the opinion that the shock was as severe as that of April 18, 1906. Early in the investigation of the latter earthquake, it became apparent that the relationship of the two earthquakes would be an essential part of the inquiry. Shortly after the earthquake of 1868 a committee of scientific men undertook the collection of data concerning the effects of the shock, but their report was never published nor can any trace of it be found, altho some of the members of the committee are still living. It is stated that the report was suppressed by the authorities, thru the fear that its publication would damage the reputation of the city. Our knowledge of that earthquake is therefore not very full, and is contained chiefly in the newspaper reports of that day. A summary of this data is given in Holden's Catalogue of Earthquakes,<sup>1</sup> and by Griesbach.<sup>2</sup>

With the object of supplementing the facts regarding the earthquake of 1868 recorded by Holden, for the purpose of comparing it with that of 1906, an inquiry was started and intrusted to Mr. A. A. Bullock. This gentleman has reviewed the periodicals of the time, and has interviewed many people who experienced the shock. He has also examined the region of maximum intensity, and has had, on several of his trips, the guidance of old residents. In response to a request by the Commission, several people have written an account of their experiences at the time of the earthquake of 1868. In this way a considerable body of valuable information has been gotten together, which supplements to an important degree the extant accounts of that earthquake.

### THE FAULT-TRACE.

It appears from Mr. Bullock's inquiries that the earthquake of 1868 was due to an earth-movement along the base of the hills which overlook San Francisco Bay on the east, and which are often referred to, particularly farther north, as the Berkeley Hills. Those hills present a remarkably even, straight front, and without doubt represent a degraded fault-scarp. Along the base of this scarp a crack opened on the morning of October 21, 1868. This crack is regarded as the trace of the fault which caused the earthquake. Its position has been determined at intervals along a nearly straight line from the vicinity of Mills College, east of Oakland, to the vicinity of Warm Springs near the Santa Clara County line; but the evidence of its existence to the northward of San Leaulro is not very satisfactory. The county was then unsettled, and the information consisted of reports of cow-boys riding the range. From San Leandro southeastward, however, the evidence is full and conclusive. The general trend of the fault is north-west-southeast; or, to be more exact, N. 37° W., a bearing almost the same as that of

---

<sup>1</sup>Smithsonian Misc. Coll., vol. xxxvii, 1898.

<sup>2</sup>Mitt. .1. k. k. Meuiograph. <ICM-IIM-II. in Wicn, Bund xii, IN(!>, pp. 22;i \*\_{ 1.

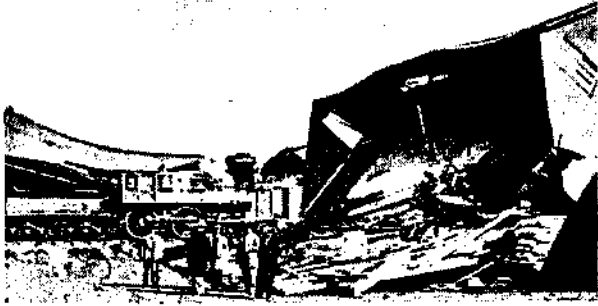

A. Flour mill, Eaywards, Wrecked 'by earthquake of 1868.

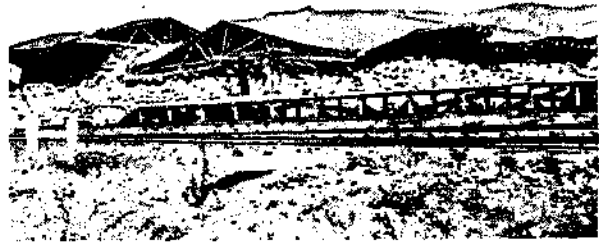

B. Edmouson's warehouse, Haywards, "Wreckedby earthquake of 1868.

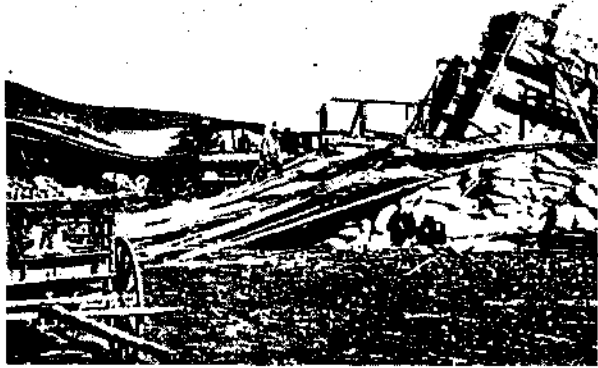

0. Flour mill and warehouse, Haywards. Wrecked by earthquake of 1868.



D. Pieroe's house, Haywards, Earthquake of 1868.



E. Haywards. Wreck of buildings by earthquake of 1868.

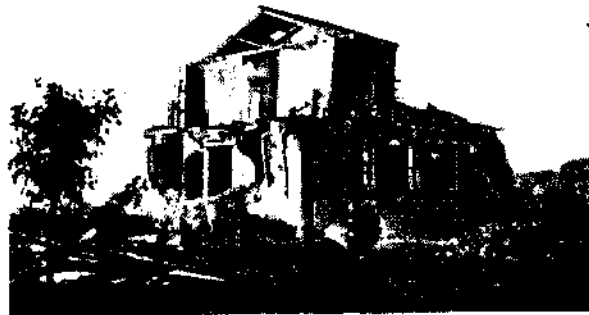

P. Ocirt-iwase, Saa L«wdrQ. Wrecked by earthquake of 1868.

From photographB presarred /hj Mr. H» Beafel,

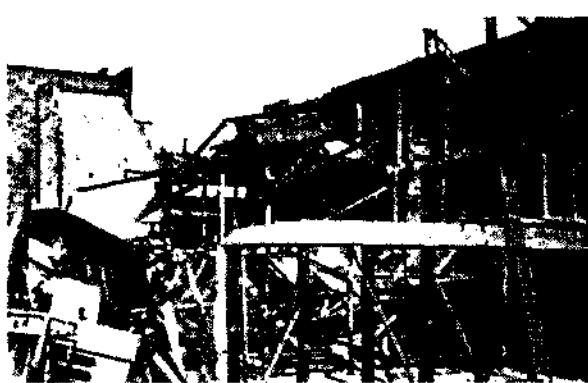
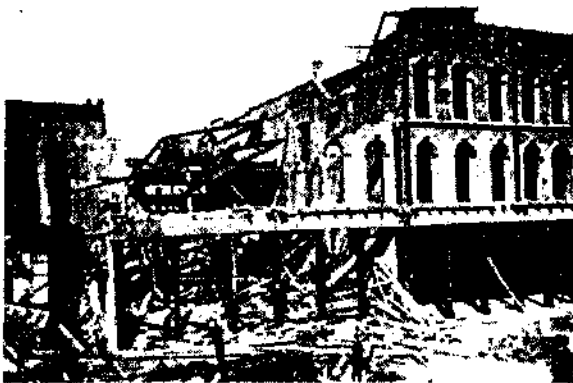
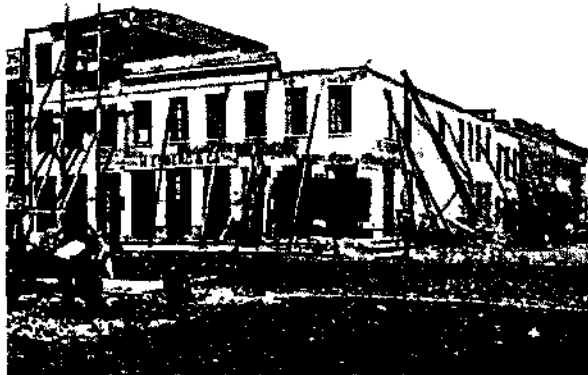
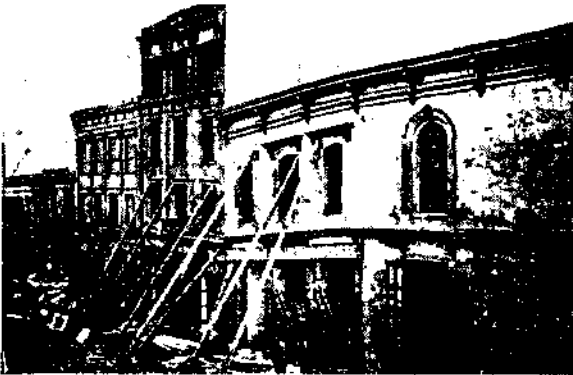

Effects of the earthquake of 1885 in San Francisco, from photographs published by Mr. E. Beadel.

the fault-trace of 1906 along the San Andreas Rift. The position of this fault-trace is shown on map 4. While in general it lies along the base of the old degraded scarp, it is still, for the most part, within the hill-slopes and not in the alluvium which extends from the base of the hills. In some places where it crossed the lower ground, the crack showed faulting or displacement of 8 or 10 inches, but from the accounts given it is not clear in what direction the faulting took place. The statements indicate a slight down-throw on the southwest side. In other places a displacement of 3 feet is said to have been observed. In places the crack along the fault-trace opened to a very considerable depth with a width of 10 or 12 inches, and remained open until filled with falling earth. On the higher ground of the hill-slopes no open crack was observed; there was merely the trace of the rupture in the sod. This fault-trace could be followed at intervals for 20 miles southeast from San Leandro, and it had a straight course without regard to the contour of the hills. In some places it was quite at the bottom of a hillside, while at other places it was high on the slope; and on at least one low hill it passed near the top through a saddle-like depression. Springs are common along the base of the hills, and the fault-trace was above the springs. According to the testimony of old residents the flow was not affected by the earth-movement.<sup>1</sup> In the hills to the northeast of the fault-trace, however, new springs were started and old ones revived, although some few ceased flowing.

That the crack extended down into the bedrock is testified to by many who observed closely. Three men reported that they tried to sound the bottom of the crack, but were unable to do so. In the vicinity of Haywards it is reported that there were two branch cracks from the main one, trending off into the hills. Water and sand were ejected from the crack in one place.

Between Decoto and Niles the crack left the base of the hill front, and deviating slightly from its general trend thus far, crossed the plain of the alluvial fan of Alameda Creek at the mouth of Niles Canyon to the foot-hills at the town of Irvington. For the greater part of this distance, it appeared as an open crack. It passed through a lagoon about 0.5 mile in length, following closely the longer axis of the depression, and the water of the lagoon was drained out, apparently into the crack. At Irvington the crack became coincident with the very straight and even ancient fault-scarp of the foot-hills southeast of that town. This ancient scarp has a strike of N. 38° W. Beyond this it was not observed farther than Aqua Caliente Creek.

Immediately to the east of Mission San Jose, entirely within the hills, another crack opened with a strike of N. 18° to 20° W.; which, converging upon the crack thus far traced, extended south as far as the county line.

The greatest intensity of the earthquake was along the crack and in its vicinity. On the projection of this line southward into Santa Clara County, the intensity diminished steadily as far as Morgan Hill, where it again rose. At Gilroy, Hollister, and San Juan, according to reports, the intensity was sufficient to throw down a few chimneys and to crack some brick and adobe buildings.

The greatest damage was done at Haywards, where nearly every house was thrown off its foundations; while at San Leandro the shock was less severe. (See plate 144.) A house near old Blair Park, in the present Piedmont district of Oakland, was badly damaged. The only other town of that date in close proximity to the fault-trace was Mission San Jose, which lies in the hills a few hundred yards west of it. In this town were several adobe buildings, one of which, a church, was wrecked. Many chimneys were thrown, but the general effect was much less severe than at Haywards.

<sup>3</sup> Tin- m>ntl<:ncr who chiefly aided Mr. Bullock in tracing out this crack were W. Smith, S. Huff, and Mr. Carthy, of San Leandro; Messrs. O. Hill, F. F. Allen, F. W. Deane, and H. V. M. M. U. of Haywards; Mr. Deruti, of Derotu; and Mr. W. Berry, of Niles.



In general, the direction of throw of objects was north or south. From several tanks the water sloped north and south. Nearly all the chimneys reported were thrown either north or south. Several frame houses were thrown south. One of these, 0.5 mile south of the line of the fault, was thrown 4 feet and another on the line was violently thrown 6 feet.

Several people report that rumblings preceded the shock, coming apparently from the south or southwest. Others saw a wave-like motion set up in the surface of the ground approaching from the south or southwest.

#### THE EFFECT OF THE EARTHQUAKE IN SAN FRANCISCO.

At San Francisco and nearby points the earthquake lasted for about 42 seconds. It was in general north and south.<sup>1</sup> A second shock followed the first at 9<sup>h</sup> 23<sup>m</sup> A. M., and lasted for 5 seconds, with the same direction as the first. Until about 12<sup>h</sup> 15<sup>m</sup> P. M., light shocks continued to be felt about every 30 minutes; and inside of the 24 hours immediately following the initial shock, 12 minor shocks were felt. The first indication of the approach of the earthquake was a slight rumbling sound, coming apparently from the direction of the ocean. The sound was heard very distinctly in the lower part of the city, but the residents on the hills do not appear to have heard it. (*San Francisco Times*, Oct. 21.) The shock commenced in the form of slow, horizontal movements. The oscillations continued from 10 to 15 seconds, growing more rapid and more violent for 6 or 7 seconds, then partially ceasing for 3 or 4 seconds, then increasing in force and rapidity for 4 or 5 seconds, then suddenly ceasing. (*Alta California*, Oct. 22, 1868.)

There were no abnormal barometrical changes at the time of the earthquake. No chronometer in Mr. Tennent's office was disturbed or showed any change of rate. The pendulum clock in his office was not stopped. A transit instrument erected on Russian Hill, belonging to him, was not disturbed in the slightest degree. Two magnets, one in his office and one in charge of a friend, showed no loss of magnetic power. One was loaded to its full extent, and the slightest loss of power would have permitted the weight to fall. (*Bulletin*, Oct. 22, 1868.)

The portion of the city which suffered most was that part of the business district, embracing about 200 acres, built on "made ground"; that is, the ground made by filling in the cove of Yerba Buena. (See plates 145 and 146.) The bottom of this cove was a soft mud varying from 10 to 80 feet in depth, and the material used to fill it was largely "dump" refuse, much of which is organic and hence perishable. Many of the buildings of that period were built flat on this filled mud, without piling, and before the land had had time to become firm. On this made land there was a very evident belt of maximum damage several hundred feet wide and running about northwest and southeast, commencing near the custom-house and ending at the Folsom Street wharf. One account of this belt goes so far as to trace 8 or 10 distinct lines of maximum disturbance, practically every building on these lines being more or less damaged, while none outside of these lines was seriously injured.

In many places the made land settled. At the junction of Market and Front Streets, the ground sank for a foot or two, and there was evidence that the tide had risen in the adjoining lot at the same time, for a pond of water collected and remained until low tide. On Pine Street, near Battery, the cobbles on the south side of the street sank away from the curbstones to the depth of 1 foot in some places; and the asphalt sidewalk on the north side was twisted and torn out of all shape, and its connection with the curb-stone severed. (*Alta California*, Oct. 22, 1868.)

<sup>1</sup> Tennent, Tinent U.S. Coast Survey, in *Alta California*, on Oct. 22, 1868, reports it as lasting 40 seconds and moving from southeast to northwest (nearly) in direction.

M A P  
O F A  
P O R T I O N O F S A N F R A N C I S C O  
S H O W I N G  
T H E D I S T R I B U T I O N A L D E G R E E O F D A M A G E  
C A U S E D B Y T H E  
E A R T H Q U A K E O F 1 8 6 8  
I N R E L A T I O N T O T H E M A R S H L A N D

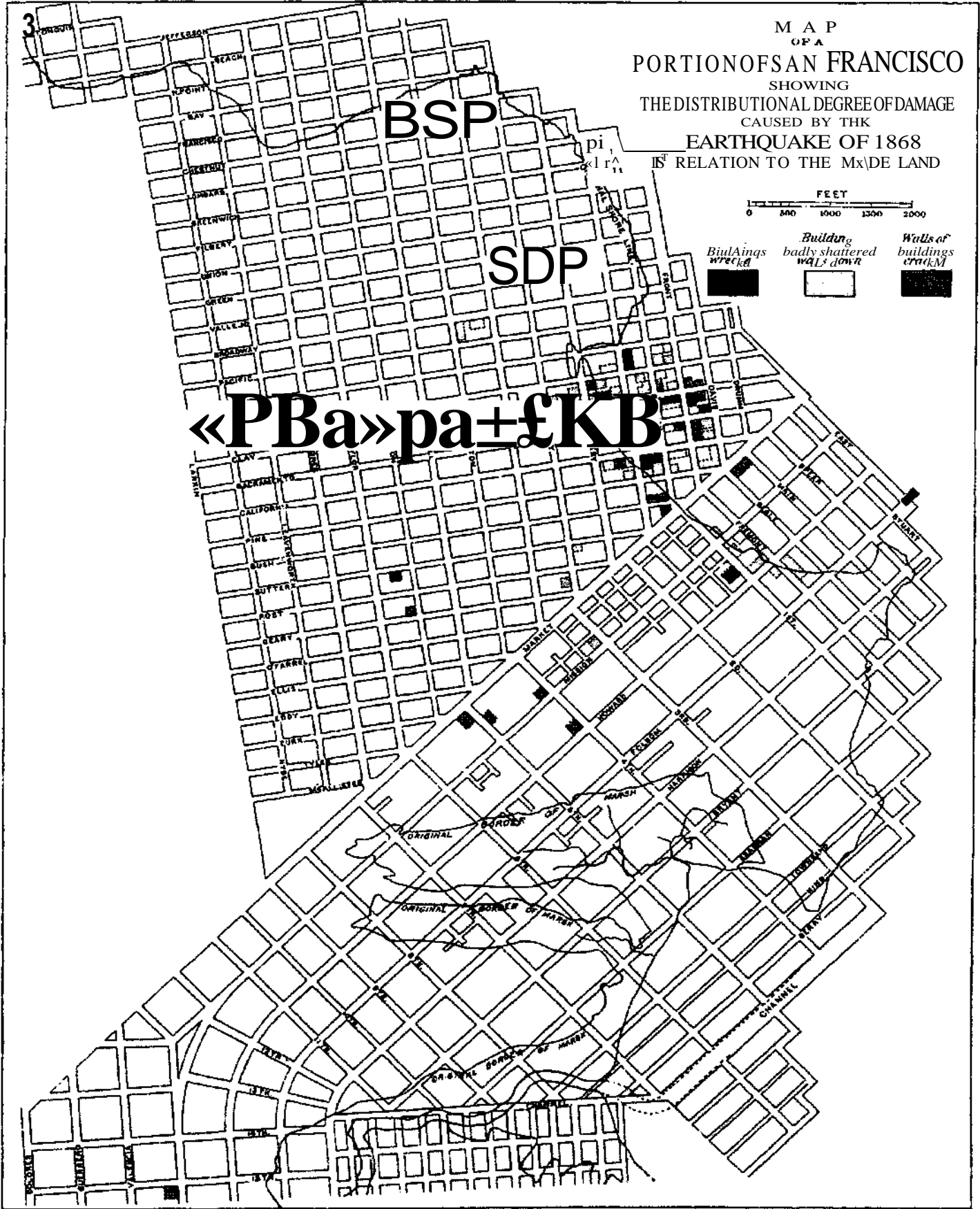

At the corner of First and Market Streets, the ground opened in a fissure several inches wide. At other places the ground opened and water was forced above the surface. (*San Francisco Bulletin*, Oct. 21, 1868.) At Fremont and Mission Streets the ground opened in many places. (*Alta California*, Oct. 22, 1868.) The general course of damage in the city was along the irregular line of the "made land," or low alluvial soil, where it met the hard or rocky base beneath it. Along the line of the old shore of Yerba Buena Cove, we found the damage to brick buildings much the largest. (George Davidson.) The custom-house, at the corner of Sansome and Clay Streets, was hurled south, by what seemed to be an undulating motion, and plaster fell. (*Bulletin*, Oct. 22, 1868.)

The outstanding portico on the east side of the custom-house was so badly shattered that it had to be removed; the main building stood fairly well, but one of the chimneys was broken across at the roof-line and turned thru an angle of over 45°. (George Davidson.)

The ground floor and the foundation of the old Merchants' Exchange appeared to have taken a different motion from the upper portion. The arch over the main corridor appeared to have been crushed. Just underneath the center, the matting was raised 2 inches. The corresponding arch at the south end of the corridor was also damaged, and there was a similar protuberance under the matting beneath it. Smaller arches at right angles to the main arches described were crushed in similar fashion. The north and south walls of the building, at the second floor, over the main arches, opened in large cracks. (*Bulletin*, Oct. 22, 1868.)

A 3-story brick structure on the corner of Market and Battery Streets, in an unfinished condition, was completely thrown down. Several different reports state, however, that it was very poorly constructed. In the Union Foundry, on First Street at the corner of Market Street, most of the machinery was displaced. (*San Francisco Bulletin*, Oct. 21, 1868.)

The floor of the Pacific foundry was raised about 2 feet in places. The center of Mission Street (opposite Fremont Street) exposed an opening from 8 to 10 inches wide; and openings of the ground were also plainly to be seen on Fremont Street, in the same vicinity. (*San Francisco Bulletin*, Oct. 21, 1868.)

Outside of the immediate district described above, damage to the rest of the city was very meager. It will be noticed in the following notes, and by a consultation of the map of San Francisco, plate 146, that the region of greatest agitation was confined to the low portions of the city, or the vicinity of some old creek bed or swamp.

The flat between Howard Street and Mission Bay was more severely shaken than Russian and Telegraph Hills; but the damage, save to chimneys and plaster, was slight. The only serious injury on Kearney Street was done to a building on the east side of the street. The building was an old one. At the corner of Fifth and Market Streets a fire-wall was thrown down. At the corner of Fourth and Bryant Streets, walls were cracked and damaged; Fourth Street near Bryant opened in places and at the crossing of Harrison and Fourth the railroad track settled about 8 inches, the planks between the rails rising about 10 inches. The Lincoln School-house (east side of Fifth Street near Market Street) was badly damaged, most of the chimneys being broken but none thrown down. The large statue of Lincoln in front of the building was ruined, but was not thrown off its pedestal. (*San Francisco Bulletin*, Oct. 21, 1868.)

The large chimney of the sugar refinery on Eighth Street fell in, crushing thru the ceilings. (Letter to *New York Times*, Oct. 21, 1868.)

A drug store at the corner of Fifth and Folsom Streets had its entire stock destroyed by falling. The chimneys of the Mission Street public school (west side of Mission Street between 15th and 16th Streets) toppled off some bricks. (*Alta California*, Oct. 21, 1868.)

A part of the brick walls of the new Calvary Church (Geary and Powell Streets) fell. A small crevice opened, as in 1865, on Howard Street beyond Sixth Street. No damage was sustained by the dry-dock at Hunter's Point. On the beach at the foot of Webster Street, below high-water mark, a fissure opened, extending lengthwise with the water. The stream of a sewer running from the Laguna to the foot of Webster Street into the bay, hitherto clear, immediately turned inky black. (*Alta California*, Oct. 22, 1868.)

The sugar refinery at North Point, a 7-story brick structure, surmounted by a tall brick chimney, was injured to the extent of losing 6 or 7 feet of its 100-foot chimney. A large fissure was made in the high bank near Fort Point and the shock was felt severely at the Fort. (*San Francisco Times*, Oct. 22, 1868.)

At the Cliff House nothing unusual took place, with the exception of a decided commotion in the ocean and "an impetus given to the every-day wave which sent it well inland, say 15 or 20 feet above the usual mark. The shock, however, did no damage, not even upsetting any of the glassware in the bar. (*Alta California*, Oct. 22, 1868.)

Upon Russian and Telegraph Hills the shock was not very damaging. In some houses on the latter ornaments were not displaced from the mantel and the inmates did not come to the doors. In others, books and ornaments fell down and marble mantels were started from their places. The oscillations on Russian Hill were more severely felt. There was a pretty general stopping of clocks, some cracking of plaster, and throwing down of light articles. (*San Francisco Bulletin*, Oct. 21, 1868.)

A pail of water, two-thirds full, on the ground at the summit of Russian Hill, slopt over both sides. (*Alta California*, Oct. 22, 1868.)

The colored Masonic Hall, Stockton Street between Pacific and Broadway, a 2-story brick structure, was badly wrecked. (*San Francisco Times*, Oct. 22, 1868.)

From the meagerness of reports it is certain that no great loss "was occasioned by the parting of water mains. The *Bulletin* for October 21 reports that the water at the Mission was shut off by the pipe being disconnected. In several parts of the city the water-pipes broke underground and caused some loss of water, but the water company soon had all repairs made. No fires are reported in the upper Mission district during the 24 hours following the earthquake. At Laguna Honda (a natural reservoir and the chief source of water supply, 2.5 miles west of Valencia and Market Streets) the water was violently agitated and the waves met in the center, throwing up a large jet several feet into the air. (*Alta California*, Oct. 22, 1868.)

The first alarm of fire was given shortly after 8 o'clock from Box No. 26 (northeast corner of Clay and Battery Streets). The fire was in Wellman and Peck's grocery (Front and Clay Streets) and was caused by matches. The chief damage was caused by water.

During the night following the earthquake, three fires occurred in the wholesale district, but there was no lack of water and all were quickly extinguished.

In the Fire Commissioner's report in the Municipal Records of San Francisco for 1868-1809, the following losses by fire are recorded: September, 1868, \$24,229; October, 1868, \$133,564.46; November, 1868, \$19,920; December, 1868, \$82,019.

The force of the shock was distinctly felt on the bay and as far as 15 miles Avost of the heads, but no great agitation of the water is reported. The tide-gage at one of the Government stations indicated no unusual rising of the tide. (*San Francisco Times*, Oct. 22, 1868.)

There was no tidal wave accompanying the earthquake. The passengers on a ferry steamer (off Angel Island) felt the shock and supposed for the time that they were aground. Many other boats reported the same experience. Two boatmen in a Whitehall boat off Fort Point report a heavy rumbling sound coming from the water. Their boat was shaken and whirled rapidly around (before the rollers reached them) and shortly they met 3 heavy rollers coming from the northwest on a calm sea. (*Alta Call-*

*fornia*, Oct. 22, 1868.) The shock of the earthquake was distinctly felt at sea near San Francisco. Captain Tobey, of the ship *Pactolus*, reported being at anchor in deep water about 15 miles west of the Heads when the shock took place. At first it seemed as if the vessel were passing over a coral shoal and striking quite heavily. The noise and motion made it seem as if the ship were dragging, with her chains also slipping out. (*San Francisco Bulletin*, Oct. 22, 1868.) The ship *Cesarewitz* felt the shock nearly out at the Farallones; the brig *Orient*, bound in, 8 miles out, experienced the shock heavily. Pilot Murphy, on a transport bound out, reported that the bark seemed to have struck bottom, her progress being impeded; and the ship, especially the yards and masts, trembled violently. (*San Francisco Times*, Oct. 22, 1868.)

The total list of casualties due directly to the earthquake numbered 5, and about 25 more occurred from secondary causes. The total loss of property was variously stated from \$300,000 to \$5,000,000. However, a careful estimate of damages made a day or two after the disaster, placed it at about \$350,000. (*San Francisco Bulletin*, Oct. 23, 1868.)

#### THE DISTRIBUTION OF INTENSITY THRUOUT THE STATE.

*Healdsburg*. — A good shaking. Heaviest shock ever felt. (*Democratic Standard*, Oct. 24, 1868.) Lasted about 10 seconds. Vibrations north and south. Clocks stopt. (*Alta California*, Oct. 22, 1868.)

*Guemerville*. — The earthquake was of great severity. It frightened my horse and he started to run away; but a large tree which had been cut nearly thru by choppers, and which they felled a few moments after the shock, was not overthrown by the shock. (I. E. Thayer.)

*Santa Rom*. — Severest shock yet felt. Lasted 10 seconds. Nearly all brick buildings in town more or less injured. Many chimneys down. (*Alta California*, Oct. 22, 1868.)

Violent and somewhat protracted earthquake. Vibrations at first from west to east, but suddenly changed from south to north, and continued about a minute. Damage to property considerable. Several brick buildings cracked. At Windsor it was lighter than in Santa Rosa, and farther north still lighter. At Sonoma, Sebastopol, Bodega, and elsewhere, the shock was severe but little damage was done. (*Santa Rosa Democrat*, Oct. 26, 1868.)

*Petaluma*. — Vibration north to south, 10 seconds in duration. Several brick buildings injured and many chimneys. (*Alta California*, Oct. 22, 1868.) Oscillations from east to west; 3 distinct shocks lasting in all 10 to 15 seconds. (*Petaluma Argus*.)

*San Rafael*. — Terrible shock. Vibrations southeast to northwest, for fully a minute. (*Alia California*, Oct. 22, 1868.)

*Napa*. — Violent shock in northeast direction for 30 seconds, accompanied by low rumbling sound. Some slight damage. (*Alta California*, Oct. 22, 1868.)

Most severe shock ever felt. Lasted 40 seconds. No serious damage to buildings. Five miles west of Napa a number of trees were overthrown. (*Napa Reporter*.)

*Vallejo*. — Earthquake severe. Many chimneys down. (*Alta California*, Oct. 22, 1868.) Heaviest shocks ever felt in Vallejo. One chimney and some plaster down. Dishes thrown from shelves. Bay smooth. (*Vallejo Recorder*.)

*Mare Island*. — Chimneys were thrown, and some buildings were considerably shaken. Shock accompanied by rumbling sound.

*Chico*. — A perceptible moving of the earth. Lamps and dishes rattled. (*Chico Courant*, Oct. 23, 1868.)

*Colusa*. — Slight shock. Not over a dozen people noticed it. (*Colum Sun*.)

*Marysville*. — Shock very light; noticed by a few only. (*Alta California*.)

*Sacramento*. — Pretty heavy shock from southeast to northwest. Plaster cracked.

Lasted 20 to 30 seconds. Water in the river receded, shoaling vessels, and then rose with a rush. (*Sacramento Union*.)

*Knight's Landing.* — "I was running a flour-mill at Knight's Landing in 1868. While the shock was not unusually severe at that place, it did some damage. The gable end of the mill warehouse was thrown down, not by the vibration of the quake, but by a pile of wheat being thrown down against it and forcing the end of the building out. I was out in a pasture at the time, pumping water for stock, and noting the water sloshing from one end of the trough to the other, I wondered as to the cause, as I had not felt the shock on account of the motion of my body in working the pump. On looking up I noticed the trees swaying back and forth, with no wind, and I knew it must be an earthquake. There was some little loss in the town in the way of broken crockery, chimneys, etc. The heaviest shock was along the edge of the valley near the Coast Ranges. In this county it was heaviest at Winters, where it demolisht John Wolf-skill's house, a stone building, and did considerable other damage." (E. H. Eastham.)

*Woodland.* — Two severe shocks, from southeast to northwest, lasting a minute. (*Alia California*, Oct. 22, 1868.)

*Suisun.* — Severe shock, north and south. Slight damage. A few brick buildings cracked. (*Solano Sentinel*, Oct. 22, 1868.)

*Solano.* — Severest shock ever felt. Sudden upheaval, attended and followed for nearly a minute by a swaying in a north and south direction. No damage except cracks in walls. (*Sacramento Daily Union*, Oct. 24, 1868.)

*Martinez.* — Some buildings damaged by cracks. Waters in front of town caused to dance. Fish rose to surface. (*Martinez Gazette*.) Court-house wrecked. (Holden.)

*Walnut Springs.* — Heaviest shock ever felt. Goods in store thrown from shelves. (*Alia California*, Oct. 22, 1868.)

*Antioch.* — Severe shock from southwest to northeast for 30 seconds. Several fissures formed in the ground. (*Sacramento Daily Union*, Oct. 23, 1868.)

*Benecia.* — At the repairing works of the Pacific Mail Steamship Company, an iron shaft of one of the side-wheel steamers was lying on the ground in a north-south direction. The earth moved from under it 9 inches, lengthwise, but in what direction is not recorded. (George Davidson.)

*Stockton.* — "I was then 13 years old. With a younger brother and a third boy I had, on the morning of October 21, 1868, gone to the edge of the tule marsh about 2 miles southwest of Stockton, to shoot ducks. Thn morning flight of birds was over, and we were returning home. My brother had his gun at the shoulder and was aiming at a meadow-lark when the earth movement commenced. The lark flew up without apparent cause, the gun moved up and down slightly, and I at once had a feeling that something unusual was happening. Within a few seconds the water-fowl, hidden from us by the tule but in countless numbers, rose with a noise like rolling thunder and took flight toward the west; while 0.5 mile to the east a small band of cattle, with heads down ami tails in the air, were racing across the country. By this time the earthquake was probably at its maximum, and, looking east, I could distinctly see the ground's surface in wave-motion, the waves apparently moving across the line of vision. During the time this motion continued, it was not perceptible as a vibration to the sense of feeling. All three of us admitted, however, that the earth felt insecure underfoot. We could detect no effect, on the water surface of the swamp. Stockton escaped with only herr and there a cracked brick wall." (C. E. Grunsky.)

Most severe shock ever felt. Vibration from northwest to southeast. West of Lodi and Woodbridge, shock was as severe as in Stockton. (*Stockton Independent*.)

In a slough water was thrown into ebullition to a height of 2 feet for a few minutes. (*Stockton Gazette*.)

*Berkeley.* — The State Institution for the Deaf, Dumb, and Blind lost 11 chimneys and 2 gables, and rear walls were cracked in several places. (*Oakland News*, Oct. 21, 1868.)

*Oakland.* — Shock preceded by a rumbling sound. Pans of milk and tubs of water emptied almost in a moment; trees whipt about like straws; many houses twisted 5 or 6 inches out of square, particularly those on brick foundations. The crashing of falling brick at the Deaf, Dumb, and Blind Institute was heard a few blocks to the south before the shock was felt. Chimneys very generally down, particularly those on south and east sides; in some parts all chimneys thrown. Many chimneys twisted, if not thrown. Many brick buildings were shattered, and several wharves went down with loads of brick, coal, hay, etc. In Brooklyn, as in Oakland, many chimneys were broken off at the roofs. (*Alia California*, Oct. 22, 1868.)

The drawbridge of the San Francisco and Oakland Railway was thrown out of place about 8 inches. (*Centennial Book of Alameda County*, p. 266.)

Thruout the city chimneys and walls fell south. (*Oakland News*.)

Of two houses next each other the older one stood on posts 4 feet above the ground, while the other was supposed to be earthquake proof. The basement walls were solid and of good workmanship. The old house was badly shaken, but not injured; the earthquake-proof house had the basement walls cracked, all the ceilings thrown down, and the marble mantel in each of the rooms thrown upon the floor. (Geo. Davidson.)

*Alameda.* — Shock very severe. Scarcely a house escaped uninjured. (*Alia California*, Oct. 23, 1868.)

*San Leandro.* — The earthquake was much more severe than in Oakland or Alameda. Not a building escaped some injury. Chimneys fell north and south. The court-house was in ruins. A tank 10 feet wide and 6 feet deep was entirely emptied of water. The bed of San Leandro Creek<sub>3</sub> which had been dry for several months, became filled with a stream of water 6 feet wide and a foot deep. A team of mules descending a hill 9 miles east of Haywards, were thrown to their knees. A rumble preceded the shock. The rangers on the old Peralta rancho said the crack past through the foot-hills on to Oakland. (Various old residents.)

*San Lorenzo.* — The limbs of a sycamore tree, 24 feet high, struck the ground. (G. Hyde.)

Flat irons and a kettle were jerked off the stove southward. (Mrs. Adams.)

House and bam were both prostrated. (Mrs. E. H. Gansberger.)

A house was thrown off its foundations. Chimneys were thrown northward. (E. Llewellyn.)

*Haywards.* — The crack past diagonally up the Haywards Hill and crest 3 feet from the south corner of the old hotel; past just east of the Odd Fellows' Building, through the Castro lot, tearing off a corner of the adobe house which stood where the jail now is, on through Walpert's Hill toward Decoto. By the hotel the crack first opened 18 to 20 inches, but soon closed to 5 or 6. It was of unknown depth; several balls of twine, tied together, with an iron sinker, failed to find bottom. There was no water in the fissure, for the iron came up dry. From the corner of B and First Streets another crack past nearly eastward toward the hills, and faded out by the sulfur spring about 1.5 miles distant. (Mrs. Wm. Haywards.) In a general way, the crack from Haywards to beyond Decoto past from 100 to 300 feet above the base of the hills. Practically not a house was left on its foundations in Haywards. At one place south of town the fault showed a throw of some 3 feet. (W. H. Weilbye.)

"Since October 5, 1862, I have lived in Haywards, Alameda County, and I well remember the earthquake of October, 1868. Being lame and having used a cane from childhood, I had never walked without it until that morning. I was working in my shop at the time. On feeling the terrible shock, and on the impetu of the moment, I managed to

get out of the building and into the street, some 18 feet distant, but on recovering from my fright I found I had left my cane in the shop. I managed to get back into the building, got my cane, and started for my house only a few yards away. The house had been thrown from its foundations, the chimney had been torn from the roof, and the porch had been wrenched away. Dishes were broken and everything was in confusion. I discovered that most of the houses were in the same condition as my own — thrown from their foundations, with chimneys down, porches knocked sideways, etc. All the while the ground was shaking and continued to shake for days and even weeks; but each shock was lighter than the last. On a certain piece of ground near the Haywards Hotel there was a common board fence, the boards abutting on the post. After the quake the boards lapt one over the other about 5 inches, the ground seeming to have been prest together that much. On going down the county road toward Oakland, we came to Mr. A. L. Rockwood's house, which had been thrown from its foundation and one end thrown into the cellar. The house was badly wrecked. In the south part of the town there was a flour mill on a foundation about 4 feet high. This building was thrown to the ground and wrecked. On the ground which is now the plaza stood a new brick warehouse filled with grain from the season's crop. The building was completely torn to pieces; grain was spilt from the sacks, and everything was in a mess. The building was 300 feet long by about 60 feet wide. A wooden warehouse about the same size shared the same fate as the brick. On B Street the ground opened about 2 inches, and water and sand were forced from the opening. Some springs were closed, while others were opened or made to flow more freely. Many wells were affected in the same manner. Mr. Charles Herman, who was in the baking business, was driving back to Haywards after delivering bread. Looking up the road, he saw the ground coming toward him in waves, and when the motion struck his horse, she went down on her knees. Mr. Herman thought the world had come to an end. As he neared the San Lorenzo Creek, he noticed that the water had been thrown out of the bed of the creek on to the road.

" At San Leandro the earthquake destroyed the brick court-house, which was then located there. A Mr. Joslyn was killed in attempting to escape from the building. Many buildings were much damaged in that town as well as in Haywards. The earthquake was the direct cause of the death of 2 persons in Haywards." (George A. Goodell.)

The crack past thru a gravel quarry practically on the summit of the first range of hills. (O. Hill.)

The crack below Haywards Hotel was 12 inches wide. It ejected water and white sand. A fence which traversed a hill from north to south was crosst by the crack, and had the ends of the boards loosened from the posts. Gradually these boards lapt over one another, until within a couple of weeks they overlapt several inches, the progress of the overlapping being noted from time to time by a pencil mark. The "cap" board of the fence was also arched up in consequence of this movement. Large waves were set up in the soil. The house was moved southward, while a neighbor's was tipt northward. (D. S. Malley.)

The rumbling preceding the shock came very distinctly from the bay, and the plain in that direction rolled like huge waves of the sea coming toward Haywards. (F. Allen.)

The crack opened parallel to Castro Street, 35 to 50 feet below Haywards Hotel. The fence passing diagonally up the hill was shortened 6 inches. (P. McKeever.)

A stove in the house was thrown north. (J. Wolput.)

A crack 3 to 4 inches wide started from the Powell place and struck across toward the county bridge next to Nettleton's, passing west of it; crosst the creek, demolisht a fence completely, and past on toward the Strowbridge residence, where the house was badly shattered. (Mrs. Hamer.)



The shock was from southwest to northeast. The ground opened from 6 inches to 2 feet, and water with sand was ejected to a height of from 1 to 3 feet. North of the village a ridge of ground 3 feet wide was raised 2 feet. By the time the shock was over, nearly the whole place was in ruins. Near Hayward's Hotel the hill shifted a good deal, and a crack opened for several hundred feet. On the hills there were several new springs. In the first 12 hours after the main shock there were 36 after-shocks. Between Haywards and Mission San Jose there were numerous cracks, so that it was difficult to drive a stage between the two towns. (*Alto California*, Oct. 22-25, 1868.)

*Mt. Eden.* — All the shelving on south side of the 2 stores of the town was thrown down. (*AIM California*, Oct. 22, 1868.)

*Alvarado.* — Shocks were violent. The ground opened in several places and water issued. (*Alia California*, Oct. 22, 1868.)

*Centerville.* — A dwelling-house was partly destroyed and 2 stores were wrecked. Hotel settled 2 feet. (*Alta California*, Oct. 22, 1868.)

*Roberts' Landing.* — "Our house broke in three pieces, each part falling outward. A boiler of hot water was on the stove, and with the first deafening jolt, the hot water came my way; giving me a bath I have never forgotten. Horses fell to the ground and men clung to some quince trees near.

"Captain Petersen, of the steamer San Lorenzo, who is now deceased, was walking along the road to Roberts' Landing when he heard a great rumble off across the fields toward San Leandro. He looked quickly in that direction, and over a mile away could see the great wave rapidly approaching. He rushed to the side of the road and had caught hold of the fence by the time the shock broke. Near him on the road a 6-mule team was drawing a load of grain, and all the mules fell flat and could not regain their feet until the great jolt was over. During the 3 or 4 succeeding days there were 150 shocks; none, of course, with anywhere near the extent of the heavy one." (R. C. Vose.)

*Decoto.* — Opposite Decoto a crack appeared about one-third of the way up the slope. It opened 10 or 12 inches at the surface and faulted about as much on the plains side. The level lands waved like the ocean, and the waves seemed to approach from the south. (Mr. Decoto.)

*Tyson Lagoon, south of Niles.*—A tank swayed north, then south, and fell. The lagoon parted lengthwise down the middle and threw water and mud both ways. After the earthquake the lagoon was dry for 3 years. It has no outlet. Rumbblings preceded the main shock and many of the after-shocks. (Mrs. Wm. Tyson.)

A crack went thru the old Shinn place, crossed the Centerville-Niles road about 0.6 mile southwest of the Southern Pacific Railway track, and past thru the Tyson Lagoon. (H. Tyson.)

*Niles.* — The water from the tank sloped nearly east. Rumbblings preceded the after-shocks. These were more severe than in April, 1906. (C. Overacher.)

A crack past thru the Shinn and Tyson places. (C. Bonner.)

*Irvington.* — Thru the north side of town a crack split the hillside, opening 7 or 8 inches and showing a fault of 8 or 10 inches. It crossed the country road  $\frac{1}{2}$  mile north of the Southern Pacific Railway depot. Its trend was N.  $45^{\circ}$  to  $50^{\circ}$  W. From three low hills the crack seemed to pass over into the tule ponds north of town. The Tyson Lagoon dried up after the quake. The rumbling preceding the shock came from the north. (R. B. Crowell.)

The railroad tracks north of the station were badly twisted for several hundred y.wk (M. Torry.)

In one place the crack on the hillside divided, and formed a narrow band, 8 or 10 feet across, which dropped below the general level of the water 8 or 10 inches. Springs were opened up on Mission Peak. (H. Crowell.) The crack which part thru the town  $\frac{1}{2}$  mile

tinued southward down the hillside about 0.5 mile northeast of the railway track. It opened 5 to 8 inches, not faulting.

"I was then about 15 years of age. My home was near Irvington. When the shock came, I was alone in the house with my baby brother. My mother was in the milk house, about 10 steps from the kitchen door. She called to me to get the baby. Tho I was thrown the length of the dining-room, I managed to get the child over my arm, face down, and a pillow on top. Then, falling and crawling, I worked my way back to the open kitchen door. My mother was on the ground. Every time she tried to get up, she was thrown again, and the milk in the buckets was spilt over her. My two brothers, my step-father, and the hired man were also down and were trying to get to the house by crawling and falling. As I sat there, I could see the ground in waves like the ocean. After the main shock, I think we had 100 shocks during the first 24 hours. The ground opened; we traced a crack thru town, and the ground settled several inches in one place. Not a house was left with a chimney on it. Our safe broke thru the floor, and the piano was out in the room nearly to the opposite side." (J. McD. Preston.)

*Mission San Jose.* — "I was curled up in a big rocking-chair, reading, and my two sisters were outside playing, when suddenly there came a swaying of the house. This lasted only a short time; then the house began to shake in earnest. My sisters began to cry and scream. I jumped out of the chair to go to them, and ran from the room, bumping against both sides of two doors. I finally reached the porch and succeeded in catching hold of a post. I distinctly remember that the pump in the yard was pumping as if some one had hold of it; and small rocks on the hill in front of the house were rolling down into the creek. The milk pans had been resting on shelves of slats; some pans slipt entirely out, some only halfway. The milk and cream were on the floor. My brother was hauling a load of wheat to San Jose. When the earthquake was at its worst, he thought his team was choking down and jumped off his wagon to find he could hardly stand. I was told at the time that the water spurted up in the streets of San Jose, and out in the road between Milpitas and San Jose, to the height of several feet. The old Mission church, which was of adobe, was shaken down, as were several other buildings at the same place. On the mountain above the old Mission, just above a place called Peacock Springs, a great crack in the earth appeared, which lookt as if the lower part of the mountain had parted and slipt down. Many times I have crost the bridge which was built over the crack, and stopt and thrown rocks down to see if I could tell how deep it was." (Mrs. N. Ainsworth.)

Along the hills back of the town and southward, passing thru the present Sinclair and Stanford ranches, the crack opened. Generally it was 10 or 12 inches wide, and faulted some 18 inches on the valley side. (A. Kell.)

The shock was preceded by a rumble passing to the northwest. Adobe building not seriously injured. Crack at Irvington and on the side of Mission Peak confirmed. (J. Sunderer.)

Brick store was cracked. Confirms cracks at Irvington. (S. Ehrman.)

Chimneys fell north and south, as they did also on April 18, 1906. (S. Murphy.)

*Warm Springs.* — The crack past along the foot-hills at an elevation of 350 to 450 feet from Niles southward, back of Mission San Jose, disappearing near the county line. In some places the fissure showed a fault of 10 to 12 inches. (H. Curtner.)

The warehouse and wharf on the slough fell, also Dixon's house. Cracks in the vicinity of Milpitas flowed artesian water for 48 hours after the shock. (Mr. Durkee.)

*Milpitas.* — Along Coyote Creek the ground was cracked from Boot's ranch to the San Francisco Bay, the cracks being on the bay side and following the winding of the creek. As in 1906 much water was ejected from the cracks, and Coyote Creek rose. (W. Bellou.)

*Calaveras Valley.* — Only one or two chimneys were dislocated. (J. Patton.)

*Santa Clara County.* — Messrs. J. W. Hines and C. Valpey, and Miss Bennett, of San Jose; Mr. H. B. Valpey, of Santa Clara; Messrs. P. Anderson and C. B. Mendor and Mrs. W. Smith, of Berryessa, all of whom were intimately acquainted with this section of the country in 1868, report that there was no crack south of the county line.

*Alcatraz Island.* — A rumbling sound accompanied the shock, and the island vibrated with a jerking motion. (Dr. L. Hubbard, U. S. A., in *San Francisco Times*, Oct. 22, 1868.)

*Colma.* — "I was then 16 years of age and lived in San Mateo County, a mile or so south of the present town of Colma. With my father I was digging and sacking potatoes in a field. I was sewing up a sack, when my father said: 'Look at that mountain. What is the matter with it?' We felt no earthquake, but the mountain seemed to be bobbing up and down. A freight train was going north along the S. P. track. Shortly after we had observed the mountain apparently moving, the earthquake reached the railroad track and the freight train appeared to gyrate like a snake. The next instant we felt it. The shock was very severe, throwing us to the ground and knocking over sacks of potatoes. A band of loose horses, including a lot of young stock, in an adjoining field, ran around the field at great speed, utterly panic-stricken. The house we lived in was in a flat some 0.5 mile from where we were at work. When we reached it, we found that milk pans in the pantry had been entirely emptied of their contents. Some panes of glass were broken and some crockery and glassware were thrown down and destroyed; but the house, a light frame building, was not injured. There were 48 shocks between the first one and midnight that night.

"I do not now recall any serious damage done in San Mateo County. There were some landslides occasioned along precipitous hills and creek banks, but the buildings in that section were all frame, and none of them were destroyed to my knowledge." (J. A. Graves.)

*San Mateo.* — Vibrations from the north for 15 seconds. (*Alia California.*)

*Redwood City.* — The court-house was wrecked and other buildings were damaged. The shock seemed to come from the southeast and lasted 30 seconds. (*Redwood Gazette*, Oct. 24, 1868.)

*Mountain View.* — Severest earthquake yet felt. Far worse than that of 1865. Shock from northwest to southeast. (*Alia California*, Oct. 23, 1868.)

*Santa Clara.* — Severe shock. Motion northeast to southwest. No serious damage. (*Aha California*, Oct. 22, 1868.)

*San Jose.* — "The most terrible earth shock ever experienced in this section since the settlement of this country by Americans, occurred yesterday morning at 8 o'clock. A dense fog hung over the city at the time, when, with scarcely a premonitory tremor, the shock was upon us in all its force. Buildings and trees seemed to pitch about like ships in a storm at sea. Fire walls and chimneys were thrown down in all parts of the city. The heavy brick cornice of Murphy's building at the corner of Market and Eldorado Streets fell to the ground. The Presbyterian Church has sustained an immense damage. The brick turrets are all down, and large portions of the steeple were precipitated thru the roof to the floor, crushing the organ and causing great damage to the gallery and fixtures below. The walls of the steeple are almost a total wreck and will have to be taken down. \$5,000 would not make good the damage done to the church. The large water-tank on the roof of Moody's flour mill fell thru the roof, carrying destruction in its course. Their wooden store-house, 100 feet in length, filled with grain, is a total wreck and the grain badly mixed. Two huge chimneys of the San Joaquin Institute were thrown down, one of them crushing thru into the rooms below. A portion of the rear wall of Welch's livery stable fell. Otter's unfinished block at the corner of Fifth and St. John Streets, sustained a very serious damage. There is not a brick building

in the city that is not more or less injured. Brick walls are everywhere wrenched and cracked and many of them are ready to fall. Another such shock would precipitate many of our brick buildings to the ground. The brick cornice of the Masonic Hall Building will have to be taken down, and the entire building, in its present condition, is decidedly unsafe for occupancy. A large quantity of crockery and glassware was broken. The destruction of plate-glass windows is very great, and much havoc is done to plastering generally. The new court-house stood the shock admirably. Some little crumbling of plaster decoration is all the damage it sustained. The lesson of the earth shock is: Erect no more high church steeples, and build no more brick buildings above 2 stories in height, and those only in the most substantial manner. A second but much lighter shock was experienced at about 10<sup>h</sup> 30<sup>m</sup> of the same day, and shortly thereafter a third shock of like character." (*San Jose Mercury*, Oct. 22, 1868.)

Where the Milpitas road crosses Coyote River, the banks were shaken together and the river-bed filled up. (*San Jose Argus*, Oct. 24, 1868.)

*Old Gilroy.*—The building shook and rocked till the occupants became seasick. The oscillation seemed to be southwest and northeast, and lasted about 30 seconds. No damage was done beyond some broken bottles in the drug store. (*Gilroy Advocate*, Oct. 24, 1868.)

Rumble preceding the shock came from the north. Chimneys fell north and south. It was fully as heavy as the shock of 1906, but not so long. The old adobe buildings were much damaged. (W. D. Dexter.)

The shock was not so severe as in 1906. (Messrs. Rice, C. Wantz, Bryant, Gilman.)

*Pacheco.*—Every brick house in town was ruined. (*Alia California*, Oct. 22, 1868.)

*San Juan.*—The shock was the heaviest since 1865. Lasted 30 seconds. (*Alta California*, Oct. 22, 1868.) No chimneys fell; 2 brick walls were cracked. (C. Bigley.)

*Santa Cruz.*—Severe shock from east to west, preceded by rumbling noise. Lasted 15 seconds. Several brick buildings badly cracked. (*Alta California*, Oct. 22, 1868.) Second only to the earthquake of 1865. Vibration from northeast to southwest for 30 to 40 seconds.

At Watsonville chimneys and plastering suffered but little. At Eagle Glen a slide 50 feet wide carried rocks and trees 1,000 feet. In Soquel a few chimneys were dislocated.

*Half Moon Bay to Pescadero.*—Chimneys down or twisted, along the coast. (T. G. Phelps, Holden's report.)

Near Pescadero limbs fell from the redwoods and large pieces of rock rolled down the mountains. (*Grass Valley Union*, Oct. 29, 1868.)

*Monterey.*—A smart little earthquake, traveling from north to south. No particular damage. (*Monterey Gazette*.)

*Downieville.*—A slight earthquake was felt. (*Mountain Messenger*, Oct. 24, 1868.)

*Grass Valley.*—Lamps vibrated. Vibrations from southwest to northeast. (*Alta California*, Oct. 22-24, 1868.)

*Nevada City.*—Three distinct shocks felt. Also felt at You Bet. (*Nevada Transcript*.)

*Placerville.*—Shock plainly felt. (*Mountain Democrat*, Oct. 24, 1868.)

*Amador County.*—The earthquake was distinctly felt at Pine Grove and Volcano. (*Alia California*, Oct. 25, 1868.)

*Jackson.*—Earthquake perceptible to a number of people. (*Amador Dispatch*, Oct. 24, 1868.)

*Folsom.*—A slight shock. Clocks stopt. (*Folsom Telegraph*, Oct. 24, 1868.)

*Sorwm.*—A slight shock. (*AUa California*, Oct. 22, 1868.)

*Tuolumne.*—Shock lasted 10 to 15 seconds. Severe. (*Tuolumne City News*, Oct. 23, 1868.)

*Snelling.* — Hard shock. No damage. (*Merced Herald*, Oct. 24, 1868.)

*Visalia.* — Shock felt by few persons. (*The Delta*, Oct. 28, 1868.)

*Nevada.* — At Gold Hill and Carson, shock perceptible to people awake, and a few people awakened. (*Territorial Enterprise*, Oct. 22, 1868.)

The shock was apparently not felt in TJKiah, Yreka, San Luis Obispo, Los Angeles, Reno, Virginia City, Alpine County, Yuba County, Trinity County, or Oregon.

## SUMMARY.

A review of the facts above presented regarding the earthquake of 1868 makes the following summary statement possible:

1. The earthquake of 1868, like that of 1906, was due to an earth-movement on a rupture plane or shear zone which was manifest at the surface as a fault-trace.

2. The fault on which the movement took place was quite distinct from the San Andreas fault.

3. It parallels the latter at a distance of about 18.5 miles to the northeast.

4. Like the San Andreas fault, it is coincident with an old diastrophic line upon which similar movements have been recurrent in time past.

5. The old diastrophic line is marked by a degraded fault-scarp, which bounds the valley of San Francisco Bay and Santa Clara Valley on the northeast.

6. Along this line there are certain geomorphic features analogous to those which characterize the San Andreas Rift.

7. The fault-trace of the fault of 1868 was much shorter than that of 1906, having a known length of only 20 miles.

8. The amount of horizontal movement, if any, was much less than on the San Andreas fault in 1906, and its direction is unknown.

9. The vertical movement appears from the accounts given to have been small also, and to have been manifest as a downthrow on the southwest or bay side, altho this is not satisfactorily established.

10. The fault-trace was characterized for the most part by a crack which in places, particularly on the lower ground, was superficially gaping. Associated with this main crack there were auxiliary branching cracks; and on the alluvial bottom-lands about San Francisco Bay there were numerous secondary cracks which were usually not discriminated by the observers of that day from the fault-trace.

11. In harmony with the shortness of the fault-trace and the small movement apparent along it, the area of destructive effect was much smaller than in the case of the earthquake of 1906. This was true also of the entire area embraced by the isoseismal II R. F. While the data are insufficient for plotting the isoseismals satisfactorily, it is nevertheless clear that these curves plotted as ellipses on the map of California would have had much shorter major axes than in the case of the isoseismals for the earthquake of 1906; while the minor axes in a northeast-southwest direction would not differ greatly for the two earthquakes. We have no authentic reports of the earthquake north of Chico nor south of Monterey, altho perceptible tremors probably did extend further south. On the other hand, in a direction normal to the fault-trace the earth-wave made itself felt as far as the State of Nevada.

12. The intensity was X in the vicinity of the fault-trace at Hayw&rds.

13. In San Francisco the chief damage caused by the earthquake was, as in 1906, on the made land and along the margin of the old shore and marsh border. But little damage was sustained by structures on the rocky slopes.

14. The foot of Market Street, San Francisco, is about midway between the San Andreas Rift and the fault-scarp upon which movement occurred in 1868. The city

has, therefore, to reckon with the latter as well as the former in its future career, and consequently should be doubly prudent in the location and structure of its important buildings.

15. The cities on the east side of San Francisco Bay are less concerned with the San Andreas Rift, but are more immediately affected by the proximity of the diastrophic line marked by the front of the range of the Berkeley Hills.

16. The interval between the disastrous movement of 1857 on the San Andreas Rift and the movement on the Haywards fault in 1868 was 11 years.

#### THE EARTHQUAKE OF 1865.

About 12<sup>h</sup> 45<sup>m</sup> r. M., on October 8, 1865, a moderately severe earthquake shook middle California. Most of our information regarding it is assembled in Holden's Catalogue of Earthquakes. In the *Sacramento Daily Union* of that date it is described as the most violent ever experienced there. After several vibrations a second or two intervened, and the shaking was then repeated more violently than at first. The vibrations seemed to be east and west, but a few peoples thought they were from southwest to northeast. Clocks stopt, and there was a general feeling of dizziness and nausea. The same paper states that at Stockton the shock was heavy and seemed to pass from north to south, but that no damage was done. At Petaluma there were two severe shocks in quick succession, vibrating from northwest to southeast. The shock was the heaviest experienced up to that time. All brick buildings were more or less injured. The first shock was from the northwest to the southeast, followed by a general shaking or rolling, closing with a jerk. At San Jose the shock was very severe. Brick walls fell and the convent bell tolled. At New Almaden a large brick store-house on the hill was nearly demolisht. Several houses in the village were thrown down. The earth opened and closed again. Chimneys in different parts of the county were thrown down. (*San Francisco Bulletin*, Oct. 12, 1865.)

At Watsonville there was a heavy shock. The earth opened in several places (secondary cracks), throwing up water. At Santa Cruz the shock was apparently heavier than elsewhere. Every brick building was reported ruined. The motion was apparently east and west. The lowlands along the river opened and spouted water like geysers. Some wells went dry or were filled with sand. The tide rose very high at the time of the shock and fell very low immediately afterwards. (*Bulletin*, Oct. 9, 1865.)

"Monterey escaped unharmed." (*Sacramento Daily Union*, Oct. 9, 1865.)

After shocks were reported at San Jose, Santa Clara, and Santa Cruz.

There is no record of the shock having been felt at Marysville, Yreka, Eureka, or in Alpine County; the *Mountain Messenger* of October 14, 1865, states that it was not felt at Visalia nor in Los Angeles. The *Bulletin* of October 17, 1865, states that it was not felt in Santa Barbara.

In San Francisco, according to the *Bulletin* of the date of the earthquake, there was a violent shock lasting about 5 seconds, followed almost instantly by another much heavier shock, which continued for 10 seconds or more. Vibrations appeared to be nearly east and west, but some experienced observers said that the movement was in the same direction as previous shocks — nearly northeast and southwest. The commencement of the shock was accompanied by a rumbling sound. During the following evening there were two or three slight after-shocks. The effects of the earthquake were visible in every street. No buildings were entirely demolisht, but the damage aggregated many thousands of dollars. The most important damage to buildings occurred at the following localities:

Corner Mission and Third Streets. Upper half of front of 4-story brick building fell; poorly constructed.	Corner Kearney and Washington Streets, City Hall had front wall badly cracked and entire building rendered unsafe.
Northeast corner Battery and Washington Streets. Old Merchants' Exchange ruined.	Washington Street, near Sansome.
Beale Street, near Market.	Market Street, near Sansome.
Kearney Street, near Sutter.	Pine Street and Front Street.
Jackson Street and Stout Alley.	Market and Pine Streets.
Mission and Fremont Streets.	Sacramento and Battery Streets.
Battery and Union Streets.	Sacramento and Webb Streets.

On the marshy lands in the vicinity of Howard and Seventh Streets the ground was heaved in some places and sank in others. Lamp-posts were thrown out of perpendicular, gas-pipes were broken, etc.

It appears probable from these scant records that the seat of the earthquake of 1865 was somewhere in the Santa Cruz Mountains, between San Jose and Santa Cruz. If this conclusion be accepted, it seems further probable, in the light of recent events, that it was due to a minor movement along the San Andreas Rift. It was probably a somewhat less severe earthquake than that of 1868. The earth movement which gave rise to the shock extended neither so far south as in 1857 nor so far north as in 1906, but appears to have pertained to that portion of the Rift affected in 1906 rather than to that affected in 1857.

The only other earthquake which can definitely be referred to a movement along the San Andreas Rift was that of April 24, 1890, which, according to Messrs. F. Abby and Charles Bigley, of San Juan, opened a fissure at that place on the line of the Rift. The railway bridge at Chittenden was displaced, as it was in 1906.

#### THE EARTHQUAKE OF 1857.

Information regarding the earthquake of 1857 is scant and generally unsatisfactory as to details. California at that date was very sparsely populated, particularly in the southern Coast Ranges, where the seat of the disturbance was. The only records that have come down to us are those of Trask, in the Proceedings of the California Academy of Sciences, Vol. 1, 1873; a note by J.S. Hittel in his "Resources of California," 1863, p. 42, and some notes in Holden's Catalogue of Earthquakes. These brief notes are supplemented by the statements of a few old residents who recall the event, some of whom were in the zone of acute disturbance at the time. The data, while insufficient for a satisfactory account of the earthquake, warrant the statement that it was due to a displacement or fault in the San Andreas Rift, along its extent from Cholame Valley to the San Bernardino Valley, a distance of about 225 miles.

According to Dr. Fairbanks, who has recently been over the course of the Rift in the southern Coast Ranges, the residents along that line have either very vivid recollection or very strong tradition regarding the rupturing of the ground at the time of the earthquake; and Dr. Fairbanks' field observations confirm the probable truth of their statements. It appears to have been generally recognized by people familiar with the southern Coast Ranges that the shock was due to or associated with the rupture of the ground, and the line of rupture is commonly referred to by the country people as the "earthquake crack." This crack, as opened in 1857, with differential displacement of unknown extent and direction, is still pointed out as a remarkable phenomenon from Cholame Valley southeastward along the northeast side of the Carissa Plain, through the Tejon Pass, thence along the southwest side of the Mojave Desert, past Lake Elizabeth and Palmdale, to the Cajon Pass and thence to the south side of the San Bernardino Range. The shock was felt from Fort Yuma to Sacramento, and the total area sensibly affected was probably not much less than in the earthquake of 1900. It was severe both at Los Angeles and San Francisco. At Los Angeles shocks continued at intervals during the

day. Mr. H. D. Barrows, who was in that city on the day of the earthquake, in a letter dated August 5, 1906, communicates the following information as to his experiences:

The great earthquake of January 9, 1857, in southern California, opened the ground for nearly 40 miles in a straight line near Elizabeth Lake. I had a brief account of it in the *San Francisco Bulletin* about February 1, 1857 — my letter (signed "Observador") being dated January 28, 1857.

Only one life was lost by that great convulsion of nature, a woman being killed at Fort Tejon by the falling of adobe walls; and, considering the colossal disturbance, very little damage was done to buildings here in Los Angeles. This is probably accounted for by the fact that our buildings were of only one story, with walls 2.5 and 3 feet thick. At the time of the great upheaval, I was in the yard at the south side of the adobe house of William Wolfskill, the pioneer, near the present site of the Arcade Depot in Los Angeles. I first stumbled toward the west, and was almost thrown down; then, after a brief period, I commenced to stumble in the opposite direction. Other persons near me stumbled in similar fashion. The long wide corridor on the south side of the Wolfskill house was hung with grapes, and I noticed that they swung back and forth clear up to the rafters. Water in tanks was thrown out in numerous instances, clocks were stopt, etc. The movement seemed to be comparatively slow, giving things time to recover after moving in one direction. If the motion had been short and sudden, the damage would have been appalling.<sup>1</sup>

All the houses in Santa Barbara were damaged by the shock of 11<sup>h</sup> 20<sup>m</sup> P.M., January 8. (Perry, Holden's Catalogue.)

At Visalia it was difficult to stand erect; treetops waved several feet to and fro; it was equally severe at places within 50 miles north and south. There were several shocks felt at Stockton and Benson's Ferry, and the principal one was very severe at Sacramento, Los Angeles, and Monterey. (*San Francisco Bulletin*, Jan. 9, 1857.)

At San Francisco the main shock was preceded by 4 slight shocks at 11<sup>h</sup> 20<sup>m</sup> p. M., January 8; 11<sup>h</sup> 33<sup>m</sup>, 4<sup>h</sup> 15<sup>m</sup>, and 7<sup>h</sup> A. M., January 9. The main shock stopt a jeweler's clock at 8<sup>h</sup> 13<sup>m</sup> 30<sup>s</sup> A. M. Prof. George Davidson, who was in the city at the time, says the shock was sudden and sharp, preceded by no noise. He was lying north and south, and felt the movement in that direction. A friend who was lying east and west was thrown out of bed.

Professor Davidson also contributes the following:

The wholesale grocery store of Goodwin Brothers faced east on Battery or Front Street, with its length of about 100 feet on Commercial Street. It was a 1-story brick structure about 15 feet high, with a flat metallic roof and a fire-wall of 3 or 4 feet above and around the roof. There were no windows nor doors on Commercial Street. The fire wall along Commercial Street was thrown bodily from the main structure into the street. The inner edge of the bricks was a straight line, at a measured distance of 6 feet from the base of the wall, while the general mass was scattered across Commercial Street. In the hardware establishment of Philip T. Southworth, along the west side of the east wall, there was a line of nail kegs, every one exactly 12 inches from the baseboard. Before the shock they had been placed close to the baseboard. These two conditions would indicate a movement of the earth from the northward and westward — roughly, from the north-northwestward. I do not remember damages to other buildings, but am satisfied there were no serious results to property. Among minor details were the effects of the shock upon one of the piled wharves, where a lot of bar-buoys had been left. They had been rolled about in every direction.

The following note on some of the effects of the shock in various parts of the state is extracted from Hittel's "Resources of California," 1863, p. 42:

The waters of the Mokulumne River were thrown upon the bank, almost leaving the bed bare in one place. The current of the Kern River was turned up stream, and the waters ran 4 feet deep over the bank. The water of Lake Tulare was thrown upon its shores, and the Los Angeles River was flung out of its bed. In Santa Clara Valley artesian wells were much

<sup>1</sup> Los Angeles is about 40 miles from the line of the Rift. A. C. L.



affected; some ceased to run, and others had an increased supply of water. Near San Fernando a large stream of water was found running from the mountains, where there had been none before. In San Diego and at San Fernando several houses were thrown down, and at San Buenaventura the roof of the Mission Church fell in. Several new springs were formed near Santa Barbara. In the San Gabriel Valley the earth opened in a gap several miles long, and in one place the river deserted its ancient bed and followed this new opening. In the valley of the Santa Clara River there were large cracks in the earth. A large fissure was made in the western part of the town of San Bernardino. At Fort Tejon the shock threw down nearly all buildings, snapped off large trees close to the ground, and overthrew others, tearing them up by the roots. It also tore the earth apart in a fissure 20 feet wide and 40 miles long, the sides of which went then came together with so much violence that the earth was forced up in a ridge 10 feet wide and several feet high. At Reed's ranch, not far from Fort Tejon, a house was thrown down and a woman in it was killed.

The most interesting fact connected with the earthquake of 1857 is that it was due to an earth movement on the same diastrophic line as that on which faulting occurred on April 18, 1906. The movement in 1857 was, practically speaking, along the southern half of the known extent of the San Andreas Rift, while that of 1906 was along the northern half.



THE CALIFORNIA EARTHQUAKE OF APRIL 18, 1906

---

VOLUME II

THE MECHANICS OF THE EARTHQUAKE

STATE EARTHQUAKE INVESTIGATION COMMISSION

ANDREW C. LAWSON

G. K. GILBERT

H. F. REID

J. C. BRANNER

A. O. LEUSCHNER

GEORGE DAVIDSON

CHARLES BUECKHALTER

W. W. CAMPBELL

# THE CALIFORNIA EARTHQUAKE OF APRIL 18, 1906

---

## REPORT

OF THE

STATE EARTHQUAKE INVESTIGATION COMMISSION

IN TWO VOLUMES AND ATLAS

---

VOLUME II

THE MECHANICS OF THE EARTHQUAKE

BY

HARRY FIELDING REID

---

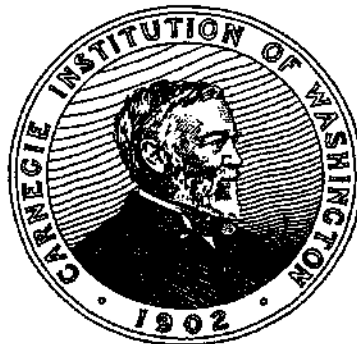

WASHINGTON, D. C.

PUBLISHED BY THE CARNEGIE INSTITUTION<sup>1</sup> OF WASHINGTON

1910

CABNEGIE INSTITUTION OF WASHING-TON

PUBLICATION NO. 87, VOLUME II

# CONTENTS.

## PART I.

### PHENOMENA OF THE MEGASEISMIC REGION.

	PAGE
THE TIME AND ORIGIN OF THE SHOCK. . . . .	3-15
Descriptions of the Shock. . . . .	3
The Beginning of the Shock. . . . .	5
The Violent Shock. . . . .	9
The Depth of the Focus. . . . .	IX
PERMANENT DISPLACEMENTS OF THE GROUND. . . . .	16-28
The Results of the Surveys. . . . .	13
The Nature of the Forces Acting. . . . .	17
Illustrative Experiments. . . . .	19
The Intensity of the Elastic Stresses. . . . .	20
The Work Done by the Elastic Stresses. . . . .	22
The Distribution of the Deforming Forces. . . . .	22
The Distribution of the Slow Displacements. . . . .	26
A Possible Origin of the Deforming Forces. . . . .	27
ON MASS-MOVEMENTS IN TECTONIC EARTHQUAKES. . . . .	20-82
The Movements before and during Earthquakes. . . . .	20
The Prediction of Earthquakes. . . . .	81
SHEARING MOVEMENTS IN THE FAULT-ZONE. . . . .	83-48
Changes in the Length of Lines. . . . .	38
Cracks in the Ground . . . . .	84
Offsets of Fences and Pipes. . . . .	85
Effects on other Structures. . . . .	87
VIBRATORY MOVEMENTS AND THEIR EFFECTS. . . . .	30-48
Character of the Movements. . . . .	38
Cracks formed in the Ground and the Breaking of Pipes. . . . .	40
Cracks in Walls and Chimneys . . . . .	48
Rotatory Movements and the Rotation of Objects on their Supports. . . . .	43
Surface Waves in the Megaseismic District. . . . .	47
THE INFLUENCE OF THE FOUNDATION ON THE APPARENT INTENSITY. . . . .	49-56
The Greater Damage on Alluvium . . . . .	49
The Theory of Mr. Rogers's Experiments. . . . .	41
Application of the Theory to Small Basins. . . . .	58
Large Basins. . . . .	54
The Foundation Coefficient . . . . .	>

## PART II.

### INSTRUMENTAL RECORDS OF THE EARTHQUAKE.

COLLECTION AND REPRODUCTION OF THE SEISMOGRAMS. . . . .	69
OBSERVATORIES AND THE DATA OBTAINED. . . . .	60-108
Berkeley, California . . . . .	62
Oakland, California . . . . .	62

	PAGE
OBSERVATORIES AND THE DATA OBTAINED — <i>Continued</i>	
Yountville, California . . . . .	62
Alameda, California . . . . .	63
San Jose, California . . . . .	63
Los Gatos, California . . . . .	64
Mount Hamilton, California . . . . .	64
Carson City, Nevada . . . . .	65
Victoria, British Columbia . . . . .	66
Sitka, Alaska . . . . .	66
Tacubaya, Mexico . . . . .	67
Cleveland, Ohio . . . . .	68
Toronto, Canada . . . . .	68
Honolulu, Hawaiian Islands . . . . .	68
Ottawa, Canada . . . . .	69
Washington, District of Columbia . . . . .	69
Cheltenham, Maryland . . . . .	70
Baltimore, Maryland . . . . .	71
Albany, New York . . . . .	71
Porto Rico (Vieques) West Indies . . . . .	71
Trinidad, British West Indies . . . . .	72
Apia, Samoa . . . . .	72
Mizusawa, Japan . . . . .	73
Ponta Delgada, Azores . . . . .	73
Paisley, Scotland . . . . .	73
Bergen, Norway . . . . .	74
Eindburgh, Scotland . . . . .	74
Tokyo, Japan . . . . .	74
Bidston, England . . . . .	75
Upsala, Sweden . . . . .	75
Shide, Isle of Wight, England . . . . .	76
Osaka, Japan . . . . .	7 6
Kobe, Japan . . . . .	77
Kew, England . . . . .	77
Hamburg, Germany . . . . .	78
Uccle, Belgium . . . . .	78
Jurjew, Russia . . . . .	78
Irkutsk, Siberia . . . . .	79
Potsdam, Germany . . . . .	81
GSttingen, Germany . . . . .	81
Coimbra, Portugal . . . . .	82
Leipzig, Germany . . . . .	82
Jena, Germany . . . . .	83
Strassburg, Germany . . . . .	84
Moscow, Russia . . . . .	84
Munich, Germany . . . . .	85
San Fernando, Spain . . . . .	85
Tortosa, Spain . . . . .	86
Kremsmiinster, Austria . . . . .	86
Krakau, Austria . . . . .	87
Granada, Spain . . . . .	87
Pavia, Italy . . . . .	88
Vienna, Austria . . . . .	89
Said (Brescia), Italy . . . . .	89
Laibaeh, Austria . . . . .	90
Triest, Austria . . . . .	90
Budapest, Hungary . . . . .	91



CONTENTS.

vii

	PAGE
OBSERVATORIES AND THE DATA OBTAINED — <i>Continued</i>	
O'Gyalla, Hungary.	91
Fiume, Hungary.	92
Florence (Xinaeniano), Italy.	93
Zagreb (Agram), Hungary.	93
Pola, Austria.	94
Quarto-Castello (Florence), Italy.	94
Zi-Ka-Wei, China.	95
Pilar, Argentina.	95
Urbino, Italy.	95
Rocca di Papa, Italy.	96
Belgrade, Servia.	97
Carloforte, Sardinia, Italy.	97
Sarajevo, Bosnia.	97
Ischia, Italy.	98
Caggiano (Salerno), Italy.	99
Taihoku, Formosa, Japan.	99
Sofia, Bulgaria.	100
Messina, Sicily, Italy.	100
Catania, Sicily, Italy.	101
Rio de Janeiro, Brazil.	101
Wellington, New Zealand.	102
Calamate, Greece.	102
Tiflis, Caucasia, Russia.	102
Taschkent, Russian Turkestan.	102
Christchurch, New Zealand.	103
Manila, Philippine Islands.	103
Tadotsu, Japan.	104
Cairo, Egypt.	104
Calcutta, India.	105
Bombay, India.	105
Batavia, Java.	106
Kodaikanal, Madras, India.	106
Perth, Western Australia.	106
Cape of Good Hope, Africa.	107
Island of Mauritius.	107
THE SEISMOGRAM AND ITS ELONGATION	109-114
Earlier Explanations.	109
A New Explanation.	110
The Stronger Transverse Waves.	111
The Separation of the First Two Phases.	111
The Direction of the Motion.	112
The Principal Part and the Tail.	118
THE PROPAGATION OF THE DISTURBANCE	115-114
The Hodographs.	115
The Preliminary Tremors.	117
The Paths of the Waves thru the Earth.	121
Relation of the Velocity to the Depth below the Earth's Surface.	117
Internal Reflections.	128
The Surface Waves.	125
Propagation along the Major Arc.	127
Equality of Velocities along Different Paths.	110
Comparison of the Hodographs of the California Earthquake with other Observed.	180
Determination of the Distance of the Origin of an Earthquake.	182

	PAGE
PERIODS AND AMPLITUDES . . . . .	135-138
During the Preliminary Tremors. . . . .	.135
During the Long Waves and the Principal Part . . . . .	.136
In the Megaseismic District. . . . .	.136
Beyond the Megaseismic District. . . . .	.137
MAGNETOGRAPH RECORDS . . . . .	.139
CONCLUSIONS. . . . .	140-142
Time. . . . .	.140
Undamped Instruments . . . . .	.140
Damped Instruments. . . . .	.141
Period of the Pendulum. . . . .	.141
Magnifying Power for Short Periods. . . . .	.141
Time-scale. . . . .	.142
Identification of the Phases on the Seismograms . . . . .	.142

## APPENDIX.

## THEORY OF THE SEISMOGRAPH.

INTRODUCTION. . . . .	.145
ROTATIONS DUE TO EARTH WAVES . . . . .	.145
FORMS OF SEISMOGRAPHS. . . . .	.147
REGISTRATION. . . . .	.148
THE MATHEMATICAL THEORY. . . . .	.148
THE HORIZONTAL PENDULUM . . . . .	.150
Determination of the Constants. . . . .	.157
Interpretation of the Record. . . . .	.166
Magnification of Harmonic Disturbances. . . . .	.172
Maximum Magnifying Power. . . . .	.175
Suspensions of Horizontal Pendulums. . . . .	.178
THE VERTICAL PENDULUM . . . . .	.179
THE INVERTED PENDULUM. . . . .	.183
SEISMOGRAPHS FOR VERTICAL MOVEMENTS. . . . .	.185
SEPARATION OF LINEAR DISPLACEMENTS AND TILTS . . . . .	.188
DEFINITIONS. . . . .	.191
USEFUL FORMULAE . . . . .	.192

## PLATES.

PLATE	FACING PAGE
1. Map showing Distances and Directions from the Origin of the Shock. . . . .	.59
2. Hodographa of the California Earthquake. . . . .	.114

PART I

PHENOMENA OF THE MEGASEISMIC REGION



# THE CALIFORNIA EARTHQUAKE OF APRIL 18, 1906.

## THE TIME AND ORIGIN OF THE SHOCK.

### DESCRIPTIONS OF THE SHOCK.

The fact that the California earthquake of April 18, 1906, occurred a little after 5 A.M., before people in general were up, is one cause why we have so little reliable information regarding the exact time at which it occurred. In answer to questions sent out by the Earthquake Commission, a very large number of replies were received, but it is quite evident, from the variations among them and from the fact that many only gave the time to minutes, that these times are very unreliable. The general descriptions show that the earthquake began with a fairly strong movement which continued with increasing strength for an interval variously estimated, but which really amounted to about half a minute; then very violent shocks occurred, and quiet was restored about 3 minutes later.

Prof. George Davidson in Lafayette Park, San Francisco, marked time from the beginning of the shock, which he places at 5<sup>h</sup> 12<sup>m</sup> 00<sup>s</sup>. He noticed hard shocks until 5<sup>h</sup> 13<sup>m</sup> 00<sup>s</sup>, a slight decrease to 5<sup>h</sup> 13<sup>m</sup> 30<sup>a</sup>, and quiet again about 5<sup>h</sup> 14<sup>m</sup> 30<sup>v</sup>.

Prof. Alexander McAdie, in charge of the Weather Bureau office at San Francisco, wrote as follows to Professor Lawson under date of September 8, 1907:

I have looked up the record in my note-book made on April 18, 1906, while the earthquake was still perceptible. I find the entry "5<sup>h</sup> 12<sup>m</sup>" and after that "Severe lasted nearly 40 seconds." As I now remember it the portion "severe, etc.," was entered immediately after the shaking.

The time given is according to my watch. On Tuesday, April 17, 1908, my error was "1 minute slow" at noon by time-ball, or time signals which were received in Weather Bureau and with which my watch has been compared for a number of years. The rate of my watch was 5 seconds loss per day; therefore the corrected time of my entry is 5<sup>h</sup> 13<sup>m</sup> 05<sup>s</sup> A. M. This of course is not the beginning of the quake. I would say perhaps that 6 or more seconds may have elapsed between the act of waking, realizing, and looking at the watch and making the entry. I remember distinctly getting the minute-hand's position, previous to the most violent portion of the shock. The end of the shock I did not get exactly, as I was watching the second-hand and the end came several seconds before I fully took in the fact that the motion had ceased. The second-hand was somewhere between 40 and 50 when I realized this. I lost the position of the second-hand because of difficulty in keeping my feet, somewhere around the 20-second mark.

I suppose I ought to say that for twenty years I have timed every earthquake I have felt, and have a record of the Charleston earthquake, made while the motion was still going on. My custom is to sleep with my watch open, note-book open at the date, and pencil ready — also a hand electric torch. These are laid out in regular order — torch, watch, book, and pencil.

Referring to the fact that his time is about a minute later than that given by other observers, he adds:

However, there is one uncertainty; I may have read my watch wrong. I have no reason to think I did; but I know from experiment such things are possible. \* \* \* I have the original entries untouched since the time they were made.

---

<sup>1</sup> The time is given in Pacific standard time, 8 hours slow of Greenwich mean time.

Prof. A. O. Leuschner, director of the Students' Astronomical Observatory of the University of California, Berkeley, gives the following account of the shock as observed by his staff in the neighborhood of the Observatory:

The only reliable record of the commencement of the feeble motion was secured by Dr. S. Albrecht and given by him as 5<sup>h</sup> 12<sup>m</sup> 06<sup>s</sup>, P. S. T. Dr. B. L. Newkirk, on the other hand, was the only observer who took pains to note the last sensible motion, for which he gives 5<sup>h</sup> 13<sup>m</sup> IV. The total duration resulting from these observations is 65 seconds. This is possibly not more than 5 seconds in error.

According to my own observations, the earthquake consisted of two main portions. They are based on counting seconds while carrying my small children out of the house. The earthquake came suddenly and gradually worked up to a maximum, which ceased more abruptly than it commenced. This [first part] lasted for about 40 seconds and was followed by a comparative lull, which was estimated at about 10 seconds. The vibrations then continued with renewed vigor, reaching a greater intensity than before and subsiding after about 25 seconds. According to these estimates the total duration of the disturbance was 75 seconds. It is, however, safe to assume that I counted seconds too rapidly in the excitement of the moment and this duration may easily be 10 seconds too long. The total duration of the sensible motion at Berkeley was probably close to 65 seconds. Dr. Albrecht reports that while he observed several severe shocks, the strongest occurred about 30 to 40 seconds after the beginning.

The mean time clock of the Observatory stopt at 5<sup>h</sup> 13<sup>m</sup> 39<sup>s</sup>, P. S. T.

Prof. T. J. J. See, in charge of the Naval Observatory on Mare Island, San Pablo Bay, reports:

I had been sleeping downstairs, lying with head to an open window, which faced the south, and as the house was not seriously endangered at any time I was favorably situated for making careful observations of the entire disturbance. I had been awake some time before the earthquake began and, as everything was very quiet, easily felt and immediately recognized the beginning of the preliminary tremors. It consisted in an excessively slight movement of the ground, which I compared to the gentle rustling of a leaf in a quiet forest; and then the tremors grew steadily, but somewhat slowly, becoming gradually stronger and stronger, until the powerful shocks began, which became so violent as to excite alarm. Their duration was unexpectedly long, about 40 seconds, according to estimate made at the time, and the subsiding tremors then began. It was just light and I could see the clock face, and I noticed that at the beginning the corrected reading was about 5<sup>h</sup> 11<sup>m</sup>, and at the end about 5<sup>h</sup> 14<sup>m</sup> 30<sup>s</sup>, so that the total duration of the disturbance including the faint tremors was about 3 minutes 30 seconds. The preliminary tremors occupied a little over a minute, the violent shocks about 40 seconds, and the final tremors about a minute and a half.

*The exact time of the phenomenon.* — This was found by the stopping of two of the four astronomical clocks at the Observatory. The violent shocks were so extreme that the pendulums were thrown over the ledges which carry the index for registering the amplitude of the swing. The standard mean time thus automatically recorded was: by the mean time transmitter, 5<sup>h</sup> 12<sup>m</sup> 37<sup>s</sup>; by the sidereal clock, 5<sup>h</sup> 12<sup>m</sup> 35<sup>s</sup>. The yard clock at the gate, which is simply an office clock, though electrically corrected from the Observatory daily, and therefore approximately correct, gave the time as 5<sup>h</sup> 12<sup>m</sup> 33<sup>s</sup>. The agreement of all these clocks is very good; but I think the best time is the mean of the two astronomical clocks, viz.: 5\* 12<sup>m</sup> 36<sup>s</sup>. I estimate that the error of this time will not exceed about 1 second. It must be remembered that the preliminary tremors before the violent shocks began would tend to derange the motions of the pendulums, and they might separate, tho the effect would probably be slight, because the tremors were not violent. It is probable that both pendulums were hung up at the first powerful shock, but as one clock is sidereal and the other mean time, there is no assurance or even probability that the pendulums would be in the same relative position at the time of the arrival of the wave which gave the powerful shock. If the pendulums were not in the same relative parts of their beats, the chances are that one would be hung fast at least a second before the other. Now it was observed that the pendulum of the mean time clock was hung fast on the west side of its arc of oscillation, while the pendulum of the sidereal clock was hung fast on the east side. Both pendulums swing in the plane of the prime vertical. The difference in the time shown by the two clocks

is probably due therefore to slight derangements by the preliminary shocks, and to the instantaneous positions of the pendulums, which enabled one to be hung fast a second or more before the other; but I think the mean time here adopted is likely to be correct within 1 second.

Mr. J. D. Maddrill, in charge of seismographs and earthquake reports at Lick Observatory, Mount Hamilton, reports the beginning of the shock there, as the result of several observations, as 5<sup>h</sup> 12<sup>m</sup> 12<sup>s</sup>. Mr. R. G. Aitken timed the heavy shock at 5<sup>h</sup> 12<sup>m</sup> 45<sup>s</sup>, which corresponds exactly with the starting of the Ewing three-component seismograph.

On comparing these accounts, we notice that Professor See alone, probably on account of his unusually favorable situation, observed a very slight movement between 5<sup>h</sup> 11<sup>m</sup> and 5<sup>h</sup> 12<sup>m</sup>, and soon afterwards the violent shocks began, which correspond to the beginning noticed by Professor Davidson, Professor McAdie, Dr. Albrecht, and the Lick observers; this part of the disturbance was very strong, tho much lighter than the very violent shocks which occurred later. We shall refer to it as the *beginning of the shock*, looking upon the earlier, extremely slight movement observed by Professor See as a preliminary movement. Dr. Albrecht reports the heaviest shock at 30 or 40 seconds after the beginning; Mr. Aitken is corroborated by the starting of the seismograph at Lick Observatory in putting the heavy shock at 5<sup>h</sup> 12<sup>m</sup> 45<sup>s</sup>, *i.e.*, 33 seconds after the beginning; and the most reliable clocks that were stop'd agree in indicating a similar interval between the beginning and the shock that stop'd them. As pointed out by Prof. C. F. Marvin,<sup>1</sup> the evidence is convincing that the clocks in general were stop'd by the *violent shock*, which occurred about a half minute after the *beginning*, and was alone strong enough to affect seismographs at distant observatories.

#### THE BEGINNING OF THE SHOCK.

The majority of the reports as to the time of the beginning of the shock are only roughly approximate, but we fortunately have four very reliable observations, all of which are given by astronomers, who are accustomed to accurate estimates of small intervals of time.

First, San Francisco: Prof. George Davidson gives the time as 5<sup>h</sup> 12<sup>m</sup> 00<sup>s</sup>  $\pm$  2 seconds, Pacific Standard Time, which is 8 hours slow of Greenwich Mean Time. Mr. Van Ordine, who had a stop-watch, gives the time as 5<sup>h</sup> 12<sup>m</sup> 10<sup>s</sup>; his watch was set two days before the earthquake and his time is not so reliable as that of Professor Davidson. Professor McAdie's time may be looked upon as confirming Professor Davidson's; all the reliable observations, as well as the reliable stop'd clocks, make it absolutely certain that the shock began about 5<sup>h</sup> 12<sup>m</sup> and we must assume that Professor McAdie, suddenly awakened by a strong earthquake, made an error in reading the minute-hand of his watch, an error which is very easy to make; or that he applied the approximate correction and wrote down the corrected time. We shall accept Professor Davidson's time as the most accurate obtainable for San Francisco.

Second, Students' Observatory, Berkeley: Dr. S. Albrecht, 5<sup>h</sup> 12<sup>ra</sup> 06<sup>s</sup>.

Third, Lick Observatory, Mount Hamilton: The result of the observations of several astronomers, 5<sup>h</sup> 12<sup>m</sup> 12<sup>s</sup>.

Fourth, International Latitude Station, Ukiah: Prof. S. M. Townley, 5<sup>h</sup> 12<sup>m</sup> 17<sup>B</sup>. Professor Townley had been at work very late the previous night and was sleeping soundly when he was awakened by the earthquake. He immediately arose and went to the window and took the time of his watch, which when corrected became 5<sup>h</sup> 12<sup>m</sup> 32<sup>s</sup>. Professor Townley estimates that 10 seconds may have elapsed from his first awakening and his reading of the watch, and that it may have taken 5 seconds for the disturbances

<sup>1</sup> Professor Marvin's Preliminary Report to the Commission on the Stop'd Clocks has been drawn upon freely in this discussion.

to awaken him, and therefore that the time of the arrival was  $5^h 12^m 17^s$ . This time is far less accurate than the others but is certainly not more than a few seconds wrong and is important in estimating the origin of the shock on account of the location of Ukiah with respect to the other stations. This will be readily seen on referring to map No. 23 and to fig. 1, in which the long vertical line represents the fault, and the positions of stations with respect to it are shown.

There are, then, only four observations which should be taken into account in estimating the position of the centrum, which, we may assume, lies somewhere in the apparently vertical plane of the fault. The question arises whether the slip took place at various parts of the fault simultaneously, or, whether it occurred first over a limited area, and the stress, being relieved here, increased at other places, and thus the rupture spread along the fault, in both directions, at a rate probably somewhat less than that of the propagation of elastic waves of compression. In the first case the movement would have been propagated at right angles to the fault, and would have arrived at the various stations after intervals of time proportional to their distances from the fault-line. Taking our origin of time at  $5^h 12^m 00^s$  we have the following data (where the  $f_s$  are the times of arrival after  $5^h 12^m 00^s$ , and the  $d_s$  are the distances from the fault-line): San Francisco,  $t_x = 0$  seconds,  $d_x = 12$  km.; Berkeley,  $t_2 = 6$ ,  $d_2 = 29$ ; Mount Hamilton,  $t_3 = 12$ ,  $d_3 = 33.7$ , Ukiah,  $t_4 = 17$ ,  $d_4 = 42.6$ . (These distances are determined from the maps and are not taken from fig. 1, where the fault is represented as perfectly straight.)

If we attempt from these data to determine the most probable value of the velocity and of the time of occurrence by the method of least squares, we find a velocity of 1.8 km./sec. and a time of  $5^h 11^m 52.5^s$ , with errors of -0.9, -1.25, -0.8, -1.0 seconds for the stations in the order given above; the sum of the squares of the errors is 8.6; the positive sign indicates that the observed times were too early, and *vice versa*. The small velocity calculated is quite inadmissible; and we therefore try the other alternative to see if it does not yield better results. We may consider that we have four unknown quantities to be determined: the time of the shock, the distance of the centrum measured along the fault-line from a given point of reference, its depth below the surface, and the rate of propagation. Four observations are sufficient to determine these four quantities, but the observations we have lead to impossible results, which may be seen by a general comparison of the positions of the stations and the times observed at them. For evidently there is no point on

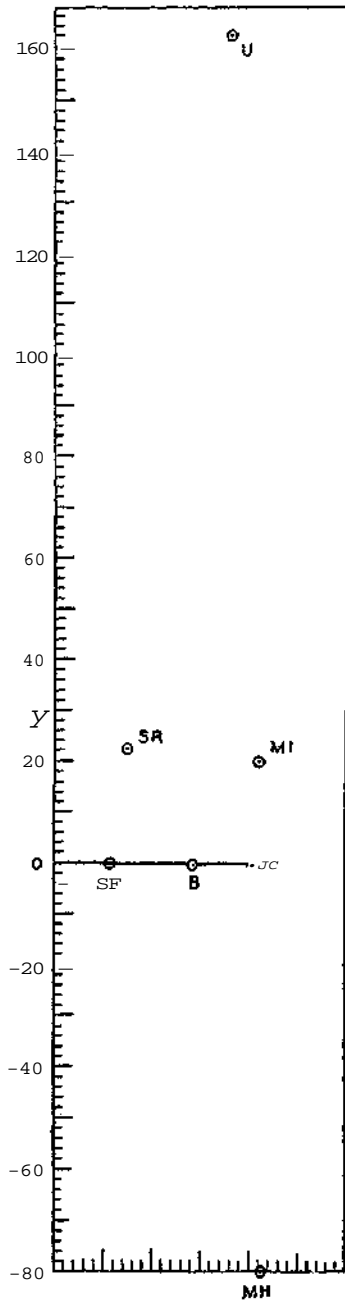

FIG. 1.

	$x(\text{km.})$	$y(\text{km.})$
Ukiah . . . . .	36.1	160
San Rafael . . . . .	15.2	25
Mare Island . . . . .	42.15	20
San Francisco . . . . .	11.7	0
Berkeley . . . . .	28.85	0
Mount Hamilton . . . . .	42.7	-80

the fault-line so situated that the difference of the distances from it of Berkeley and San Francisco is half the difference of the distances from it of Mount Hamilton and



San Francisco, and one-third the difference of the distances of Ukiah and San Francisco; which shows that the observations are not accurate enough to make an exact determination of the unknown quantities possible. We are led therefore to assume a rate of propagation, and by trial to find the place on the fault-plane which will accord best with the observations; that is, which will make the sum of the squares of the errors least. In the neighborhood of an earthquake origin, the preliminary tremors, the second phase, and the long waves (which will be described further on) are not separately distinguishable; and there are very few and unsatisfactory observations regarding the rate at which the disturbance is propagated.

Professor Imamura<sup>x</sup> calculates the velocity as 7.5 km./sec. from observations at Tokyo of earthquakes originating at an average distance of 679 km., the greatest distance being less than 1,300 km. Corresponding observations at Osaka give a velocity of 7.9 km./sec. for an average distance of 792 km., but they are rendered unreliable on account of the poor clock at that station. By the difference method, that is, by dividing the difference of the distance from the origin of two stations by the difference of time of arrival at them, he finds an average velocity of 12.1 km./sec, the stations ranging in distance between 284 and 1,285 km. from the origin. From observations at Tokyo and Mizusawa he finds by a similar method an average velocity of 9.6 km./sec. for an average distance of 522 km. from the origin, and 12.4 km./sec. for an average of 984 km.

Professor Omori<sup>2</sup> finds for the velocity of two earthquakes between Taichu, near their origin in Formosa, and Tokyo, a distance of 1,620 km., 6.13 km./sec. and 6.75 km./sec, respectively. Tokyo is 1,710 km. from the origin and Taichu 90 km. In the first case the time at Taichu was determined by a chronometer watch, in the second from the seismogram; in both cases the Tokyo time was determined from the seismograms.

Professor Credner<sup>3</sup> finds by the difference in time of arrival at Leipzig and Göttingen of two small earthquakes whose origins were about 100 km. south of Leipzig, a velocity of 5.9 km./sec. Göttingen is about 200 km. from the origin.

Professor Rizzo<sup>4</sup> from observations of the Calabrian earthquake of 1905 at two stations, Messina and Catania, distant 84 and 174 km., respectively, from the epicentrum, finds a surface velocity of 6.9 km./sec; this supposes the centrum at the surface; a deeper centrum would give a slightly smaller velocity. The tendency is always to obtain too low a value for the velocity. The strongest disturbance does not usually occur at the very beginning of the shock, but somewhat later; the earlier and lighter part is felt near the origin, but at a distance only the stronger part is observed; this is also true of seismograph records. The velocities calculated from such observations are evidently too small.

Professor Wiechert in a communication to the International Seismological Association in September, 1907, accepted 7.2 km./sec. as a fair value of the velocity near the surface of the earth; which is the same as the velocity near the origin. I have taken this value, 7.2 km./sec, as being probably as near the truth as we can come at present. With this velocity we find by the method of least squares that the most probable position of the centrum is at a point lying about 10 km. north of the point on the fault-line opposite San Francisco, and at a depth of 20 km. below the surface; the time of occurrence of the shock is 5<sup>h</sup> 11<sup>m</sup> 57.6<sup>s</sup>; and the errors in seconds are: San Francisco, +1.1; Berkeley, — 3.4; Mount Hamilton, — 0.2; Ukiah, -f 2.4; the sum of the squares of the errors is 18.6 seconds. The objection to this determination is the error at Berkeley which is

<sup>1</sup> Publications of the Earthquake Investigation Commission in Foreign Languages, No. 18, p. 102.

<sup>1</sup> Note on the Transit Velocity of the Fonnosan Earthquakes of April 14, 1906. Bull. Imperial Earthquake Investigation Commission, vol. i, No. 2, p. 73.

<sup>1</sup> Die Vogtlandische Erdbebenschwärm von 13 Feb. bis zum 18 Mai, 1903. Abh. math.-phys. Kl. K. Sachs. Gesells. d. Wissen. 1904, Bd. xxviii, p. 153.

<sup>4</sup> Sulla Velocità di Propagazione delli Ondi Sismiche nel Terremoto della Calabria. Accad. R. delli Science di Torino, 1905-1906, p. 312.

apparently too large. The 15 seconds which Professor Townley allowed for the interval between the arrival of the shock at Ukiah and the moment that he read his watch seems to me rather long; if we reduce this interval to 12 seconds and take the time of arrival at Ukiah at  $5^{\text{h}} 12^{\text{m}} 20^{\text{s}}$ , the observations become more accordant; we find that the best position for the origin has the same geographical position mentioned above, but the centrum is near the surface, and the time of the shock becomes  $5^{\text{h}} 11^{\text{m}} 59^{\text{s}}$ ; the errors of observations are: San Francisco, + 1.1; Berkeley, -2.8; Mount Hamilton, +0.9; Ukiah, + 0.7. The sum of squares of the error is 10.4 seconds. But the position of the centrum can not be looked upon as being determined very accurately; even if we put its depth at 30 km. we find the sum of the squares of the errors only 10.8 seconds; and the individual errors are: San Francisco, +1.9; Berkeley, -2.6; Mount Hamilton, + 0.6; Ukiah, +0.2. This is a better group of errors, as that of Mount Hamilton is very small. The time is  $5^{\text{h}} 11^{\text{m}} 57.7^{\text{s}}$ .

It will be noticed that the groups of errors seem slightly to favor the idea of a simultaneous slip along the fault-line in preference to the slip beginning over a small area and then gradually spreading along the line. But let us notice what this really involves. In the first place it requires a velocity of propagation of only 1.8 km./sec, a value less than a quarter as great as the most probable value of this velocity.<sup>1</sup> It may be urged that these times refer to the arrival of the large surface waves, whose velocity has been determined as about 3.3 km./sec.; but with this value of the velocity we find much larger errors, the sum of the squares amounting to 36.9; and therefore a consideration of the errors alone renders this supposition less probable than either of the other two; and, moreover, the preliminary tremors and large waves are not separated at such short distances from the origin as San Francisco and Berkeley.

Secondly, it is clear from the surveys of Messrs. Hayford and Baldwin (vol. i, pp. 114-145) and from the discussion of them (pp. 16-28) that the rupture along the fault-line was the result of gradually increasing forces which finally became greater than the strength of the rock; before rupture the rock yielded elastically to the forces and it seems absolutely impossible that its ultimate strength, varying locally, should have been reached simultaneously over the whole area of the fault-plane, whose length was 435 km., or indeed over any large area. It would require a nice adjustment of the forces concerned, which the nature of the forces in no way leads us to expect. It is only in the case of absolute rigidity, which is far from the true nature of rock, that we can conceive of a simultaneous movement along the whole fault; and then we should be at a loss to account for the dying out of the fault at its ends. Moreover, our general experience is entirely against simultaneous yielding; when structures, such as bridges, break, they give way first at a particular point; when an ice-jam in a river yields, one part yields before the rest; and, indeed, many such examples might be cited. We are therefore constrained to believe that the rupture on the fault-plane began over a small area and rapidly spread to other parts of the fault.

We may then consider the position of the origin as determined within, perhaps, 30 km. along the fault-line and within 20 km. in depth; and the time, within 3 seconds; and we may write for

$$\text{The beginning of the shock} \left\{ \begin{array}{l} t_0 = 13^{\text{h}} 11^{\text{m}} 58^{\text{s}} \pm 3 \text{ seconds G. M. T.,} \\ A = 121^{\circ} 36' \text{ W. } \pm 16', \\ \quad = 370.4^{\circ} \text{ g. N. } \pm 16', \\ \phi = 37^{\circ} 49' \text{ N. } \pm 16', \\ z_0 = 10 \text{ km. } + 20 \text{ km. or } - 10 \text{ km.,} \end{array} \right.$$

where  $t_0$  is the time of the occurrence of the shock;  $X$ , the longitude, and  $\phi$ , the latitude,

<sup>1</sup> If we had taken the Ukiah time as  $5^{\text{h}} 12^{\text{m}} 20^{\text{s}}$ , the hypothesis of simultaneous slip would have required a velocity of 1.6 km./sec, and the sum of the squares of the errors would have been 17.4.

of the epicentrum; and  $z_0$ , the depth of the centrum. The point lies exactly opposite the Golden Gate.

If, instead of a velocity of 7.2 km./sec. we had used 6.5 or 8, the position and time of the shock would not have been altered beyond the limits of error indicated above. A smaller velocity would have led to a deeper centrum and earlier time; a greater velocity would have had the opposite effect.

#### THE VIOLENT SHOCK.

The violent shock is the most important part of the earthquake, both on account of its destructive effects and because it alone could have affected distant seismographs. Indeed, Victoria is the only distant station where the first motion was recorded and it is the nearest seismographic station beyond the limits of sensible motion. Its distance was 1,156 km. from the origin and the disturbance was perceptible to a distance of 550 km. A large number of clocks were stopt by the strong motion; and one would naturally look to them to get the exact time of its occurrence. Professor Marvin has collected together all information regarding these clocks. For the great majority the time of the stopping is only known to minutes, and even then the differences between the various clocks are so great as to make the resulting average of very little value; it is therefore not necessary to give here the times recorded by all of them. We fortunately have observations from four stations which seem to be very reliable.

First, San Rafael: Two standard clocks were stopt; one the standard clock of the Time Inspector of the North Shore Railroad, stopt at  $5^{\text{h}} 12^{\text{m}} 35^{\text{s}}$ ; the other, belonging to the night operator of the Railroad, stopt at  $5^{\text{h}} 12^{\text{m}} 30^{\text{s}}$ . Also a clock, belonging to the Western Union Telegraph Company, which sends out the time, stopt, the time being  $5^{\text{h}} 13^{\text{m}}$ ; as the seconds are not given it is probable that they were not observed. This time must, therefore, be neglected; it is manifestly too late. The first two clocks are supposed to be very accurate and to be checked every day at noon. The average of their time is  $5^{\text{h}} 12^{\text{m}} 32.5^{\text{s}}$ .

Second, Mare Island: Two of the astronomical clocks, under the charge of Prof. T. J. J. See, stopt respectively at  $5^{\text{h}} 12^{\text{m}} 35^{\text{s}}$  and  $5^{\text{h}} 12^{\text{m}} 37^{\text{s}}$ . A third clock which is electrically corrected every day, but is not a standard clock, stopt at  $5^{\text{h}} 12^{\text{m}} 33^{\text{s}}$ . Professor See thinks the best time is the average of the two astronomical clocks, namely,  $5^{\text{h}} 12^{\text{m}} 36^{\text{s}}$ .

Third, Berkeley: The astronomical clock at the Students' Observatory, under the charge of Prof. A. O. Leuschner, stopt at  $5^{\text{h}} 12^{\text{m}} 39^{\text{s}}$ .

Fourth, Mount Hamilton: The only clock that stopt was a small one in the Director's office, the correction for which was not accurately known; it stopt at  $5^{\text{h}} 12^{\text{m}} 52^{\text{s}}$ ; we can not put any reliance on the exact time it gives. The shock began at Mount Hamilton at  $5^{\text{h}} 12^{\text{m}} 12^{\text{s}}$ , but the strong shock occurred at  $5^{\text{h}} 12^{\text{m}} 45^{\text{s}}$ . This is attested by the observation of Mr. Aitken and also by the fact that the Ewing seismograph was set in motion at that time. This seems the most accurate record we have of the time of the arrival of the heavy shock at a station near the origin.

The sidereal clock at the Chabot Observatory, Oakland, stopt at mean time  $5^{\text{h}} 12^{\text{m}} 51^{\text{s}}$ . The mean time clock stopt at  $5^{\text{h}} 14^{\text{m}} 48^{\text{s}}$ . Professor Marvin, however, has pointed out that the delicate gravity escapement of the latter might easily be thrown out of adjustment by the disturbance and thus allow the clock to race. It is evident that we can not take into consideration the time given by it. The sidereal clock, stopping 14 seconds later than the clock at Berkeley, may perhaps have been stopt, restarted, and stopt again by the shock. At any rate it is certainly too late and must be neglected. One clock at Ukiah may have been stopt and restarted; it was going after the shock,

but had been retarded by 6 seconds in time. Two of the astronomical clocks at Mare Island continued going after the shock, but they lost 20 seconds, which Professor See ascribed to "the rubbing of the pendulum points against the index ledges, which was also clearly shown by the brightening of the metal of the indexes." Altho this friction must have acted, it hardly seems sufficient to account for so large a loss in the minute or so of the strong shocks, and it is not unlikely that these clocks were stopt and started again. Some clocks must have been stopt at very nearly the correct time of the arrival of the shock, but it is impossible to distinguish them from other clocks, whose times are claimed to be correct, but which were evidently wrong; it is best, therefore, only to use times from the first four observations mentioned, which have been chosen because they can be relied on as very nearly correct.

The clocks which stopt evidently too late, and those which continued going but with the loss of some seconds of time, call attention to an error which may be made if we accept the time of a stopt clock as determining the time of the heavy shock. Let us notice in the first place that it is scarcely possible for the time thus determined to be too early; for, if the pendulum is made to vibrate too rapidly for a beat or two before it is stopt, the time is advanced; and if the pendulum is stopt, started, and stopt again, the clock will mark too late a time. It is only in case the gentler motion preceding the heavy shock should cause the pendulums to vibrate too slowly, that the stopt clock would indicate too early a time; but this gentler motion is just as apt to make the pendulums vibrate too fast. The difference between the time of the heavy shock at Mount Hamilton, which does not depend upon a stopt clock, and the times recorded by the stopt clocks at San Rafael, Mare Island, and Berkeley, make it evident that the latter could not indicate a time materially too late, unless we assume a rate of propagation of the disturbance much too low to be permissible. It is extremely probable, however, that the clocks did indicate a time slightly too late, and I have therefore taken for the times of arrival of the heavy shock at Mare Island and Berkeley one second earlier than the clocks indicated; these clocks were all astronomical clocks, and, with their known corrections, were practically correct just before the shock. The clocks at San Rafael were not astronomical clocks and may have been a little too fast; we can take  $5^{\text{h}} 12^{\text{m}} 32^{\text{s}}$ , a half second earlier than their average, as the time of the shock at that place. The time at Mount Hamilton requires no modification.

We have therefore for the times, after  $5^{\text{h}} 12^{\text{m}} 30^{\text{s}}$ , of arrival of the heavy shock and the distances of the stations from the fault-line: San Rafael,  $t_1 = 2$  seconds,  $d_1 = 16$  km.; Mare Island,  $t_2 = 5$ ,  $d_2 = 42$ ; Berkeley,  $t_3 = 8$ ,  $d_3 = 29$ ; Mount Hamilton,  $t_4 = 15$ ,  $d_4 = 33.7$ . A glance at these data show that the shock was not simultaneous along the fault-line, for Berkeley and Mount Hamilton, less distant from the fault-line than Mare Island, felt the shock later. The times, with the positions of the stations as shown in fig. 1, indicate that the strong shock originated in a limited area somewhere to the northwest of San Rafael.

If, as in the case of the *beginning of the shock*, we use these four observations to determine our four unknown quantities, we find an imaginary value for the depth of the centrum, showing that the observations are not perfectly accurate. We may then, as before, assume various positions for the centrum and find by the method of least squares what time of occurrence and what velocity of propagation will make the sum of the squares of the errors least. The following table shows the results of these determinations;  $y_0$  is the distance from a point on the fault-line opposite San Francisco to the origin, measured towards the northwest;  $z_0$  is the depth of the centrum below the surface;  $t_0$ , the time of occurrence, in seconds after  $5^{\text{h}} 12^{\text{m}} 30^{\text{s}}$ ;  $v$ , the velocity of propagation in kilometers per second; and  $A^2$ , the sum of the squares of the errors in seconds between the calculated and observed times. It is to be noticed that the velocity is too high except in one case.

TABLE 1. — *Times, Velocities, and Errors for Various Positions of the Focus.*

$y_0$	$z_0$	$t_0$	$v$	$\Delta^2$
20	0	31.0	7.7	5.0
20	20	29.8	7.2	10.2
40	0	30.1	8.3	4.9
40	20	28.9	8.7	5.9
50	20	29.2	8.8	5.3

If now we assume a velocity of 7.2 km./sec, and repeat the calculations determining only  $t_0$ , we get the following results for various positions of the centrum:

TABLE 2. — *Times and Errors for Various Positions of the Focus.*

$y_0$	$z_0$	$t_0$	$A^2$	$y_0$	$z_0$	$t_0$	$A^2$
20	0	30.5	9.3	50	0	27.8	7.6
20	20	29.8	10.2	50	20	27.4	7.7
30	0	29.8	8.9	60	0	26.7	8.3
30	20	29.2	7.2	60	20	26.2	7.6
40	0	28.9	6.7	60	40	25.1	6.7
40	10	28.8	6.9	100	0	21.9	16.6
40	20	28.4	6.6	100	20	21.6	16.0

There is not a very great difference in the sums of the squares of the errors for values of  $y_0$  varying between 20 km. and 60 km., but they increase at both of these extreme distances (errors of a few tenths are insignificant as they are partially due to approximations in the calculations); and the times of course become earlier as the origin is placed further northwest. We may therefore adopt for the approximate position of the centrum of the violent shock,  $y_0 = 40 \text{ km.} \pm 20 \text{ km.}$ ,  $z_0 = 20 \text{ km.} \pm 20 \text{ km.}$ , and for the time of occurrence,  $t_0 = 5^{\text{h}} 12^{\text{m}} 28^{\text{s}} \pm 2 \text{ seconds}$ . The individual errors of the times of observation become at San Rafael, Mare Island, Berkeley, and Mount Hamilton, respectively, + 0.6 second, - 0.4, - 2.1, + 1.3. If in these calculations we had used a velocity of 6 km./sec. or 8 km./sec, our results would not have been altered beyond the uncertainty indicated. We may therefore write for

$$\text{The violent shock } \left\{ \begin{array}{l} t_0 = 13^{\text{h}} 12^{\text{m}} 28^{\text{s}} \pm 2 \text{ seconds G. M. T.}, \\ \bar{X} = 122^{\circ} 48' \text{W.} \pm 5', \\ \langle z \rangle = 38^{\circ} 03' \text{N.} \pm 4', \\ z_0 = 20 \text{ km.} \pm 20 \text{ km.} \end{array} \right.$$

The point lies between Olema and the southern end of Tomales Bay. This position of the point of beginning of the *violent shock* receives some confirmation by the fact that the violence of the shock was probably as great in this neighborhood as anywhere, and that the displacements along this part of the fault-line were the greatest recorded.

THE DEPTH OF THE FOCUS.

There are two ways of determining the depth of the focus: by observations of the times of arrival of the shock at various stations and by a consideration of the distribution of the damage and other effects produced by the disturbance over the surface of the earth. The two methods do not determine identically the same point. The time method gives the location and depth of the point where the shock started, whereas the method depending upon the distribution of intensity gives the depth of the whole of the fault-plane.

First: a glance at fig. 2, where  $F$  represents the focus of the shock, will show very clearly that the distance from the focus to the various stations depends upon its depth, and if we

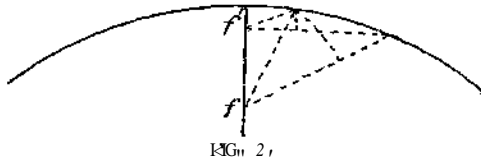

FIG. 2,

knew the exact time of the shock, the time of the arrival at the stations and the velocity of propagation, we could immediately calculate the depth of the focus. As a matter of fact we do not know the exact time of the shock, nor do we know the exact velocity, but by

observations at a number of stations all these quantities could be determined, provided the observations were sufficiently accurate. Here, however, is where the difficulty lies. The table on page 119, which gives the time of the arrival of a disturbance according to the distance of the station from the epicenter and the depth of the focus, shows that this time is very slightly affected by the depth of the focus when the distances are as great as three or four times this depth; and therefore to get from time observations an even fairly approximate value of the depth we must have a number of stations very close to the epicenter, and the observations must be extremely accurate — to within a second or so. Neither of these conditions have been satisfactorily fulfilled heretofore, and determinations of the depth of the focus based on this method are unreliable. In the case of the California earthquake the observations at the four stations considered are probably more favorable, both as to the situations of the stations and the accuracy of the observations, than has been realized at any former earthquake; but nevertheless it has been shown that they are not sufficiently accurate to determine the various unknown quantities in the problem, and they merely indicate that the depth at which the violent shock originated is probably not more than 40 km. The variation of this method by the use of Seebeck's or Schmidt's hodographs can not yield more reliable results; and its application when the time of arrival, not of the beginning of the shock, but of a strong reinforcement of the motion, is used is by no means to be recommended; for in this case we can not say that the special part of the disturbance observed has traveled directly thru the body of the earth; and the whole theory of the method depends upon this supposition. In some cases it is quite evident that the time of arrival of the long waves has been used, and these waves are supposed to be propagated along the surface.<sup>1</sup>

Second: the distance of points from the focus will increase more slowly with their distance from the epicenter for deep than for shallow foci, and therefore the intensity of the action at the surface will diminish more slowly. Maj. C. E. Dutton has shown that if we consider the extent of the origin small and the damage done by the shock at the surface proportional to the energy of the motion there, the change in the amount of damage will be most rapid at a distance from the epicenter of about 1.7 times the depth of the focus; and this distance is independent of the actual intensity of the shock.<sup>2</sup>

If we attempt to apply this method to the California earthquake, we meet with many difficulties. The disturbance was by no means confined to a small area, but was spread, more or less unevenly, over the whole fault-plane. It probably did not take place simultaneously, but varied in time at different parts of the fault. If it had occurred simultaneously, the method might be applied by adding up the effects due to the different parts of the fault, but if the movement occurred even at slightly different times in different parts of the fault, their effects at some points would be successive and at some points simultaneous. The general averaging of these results might, however, enable us to form a rough

<sup>1</sup> See for example Faidiga; "Das Erdbeben vom Sinj am 2 Juli, 1895," Mitt. Erdb.-Com., K. Akad. Wiss. Wien, No. XVII, 1903. The time of arrival of the second preliminary tremors would be a better time to use than that of the first preliminary tremors; for they travel only about two-thirds as fast, and therefore the differences in their times of arrival would be somewhat greater at two stations of slightly different distances from the centrum.

<sup>2</sup> The Charleston Earthquake of August 31, 1886. 9th Ann. Rep. U. S. Géol. Surv., 1887-1888, pp. 313-317.

estimate of the depth if we were not confronted by another difficulty, namely the variations of the effects due to the character of the foundation. These variations, as shown on the general map, No. 23, and on the intensity map of the city of San Francisco, No. 19, are so great that it is quite impossible to obtain accurate values for the depth of the fault all along its course; but opposite Point Arena the isoseismals are sufficiently regular to throw some light on the subject. In attempting to solve this problem, we must make a number of assumptions, which are by no means exactly true, but are nearly enough so to make our result of some value; they are: that the amount of energy sent out by each element of the fault-plane per unit time was the same; that the amount of energy sent out in any direction from each element was proportional to the cosine of the angle between that direction and the normal to the fault-plane; that the strong disturbance continued for a sufficient time all along the fault-plane to permit us to assume that points not very distant were receiving simultaneously the strong vibrations from a length of the fault-plane 8 or 10 times as great as their distances from it; and that the effective force at any point is proportional to the square root of the energy of the disturbance at that point.

With these assumptions we can determine the energy of the disturbance at any point not far from the fault by adding together the amounts of energy sent to that point by each element of the line.

The vibrational disturbances at the various points of the fault-plane do not unite to form a single wave-front, for the movements must be in different phases at different points, and both distortional and longitudinal vibrations in various directions are present; for this reason it might appear that the energy would be sent out uniformly in all directions and not according to the cosine law; but if we make this assumption, we find an infinite amount of energy near the fault, which is, of course, impossible, and we are therefore led to assume the cosine law, which is probably not very far wrong.<sup>1</sup>

For a simple harmonic vibration of a given period the energy of the motion is proportional to the square of the amplitude, and the maximum acceleration to the amplitude itself, that is, to the square root of the energy. When we consider that, at every place where the disturbance was felt, the vibrations were in all directions and had various periods and amplitudes, we see that it is quite impossible to determine the true acceleration, but the square root of the energy will be roughly proportional to it. Professor Omori has shown that the effective force is proportional to the acceleration and has estimated the values of the various degrees of the Rossi-Forel Scale in terms of actual accelerations.<sup>2</sup>

In fig. 3 let  $P$  be the point on the earth's surface at which the disturbance is to be determined and  $x$  its perpendicular distance from the fault-plane,  $O'Obb''$ . Let  $b$  be any element of the fault-plane, whose depth below the surface is  $z$  and whose distance from  $O'$ , measured parallel to  $O'b'$ , is  $y$ . Then the energy of the disturbance at  $P$  is found by adding the amounts sent from all such elements of the fault-plane, remembering that the intensity

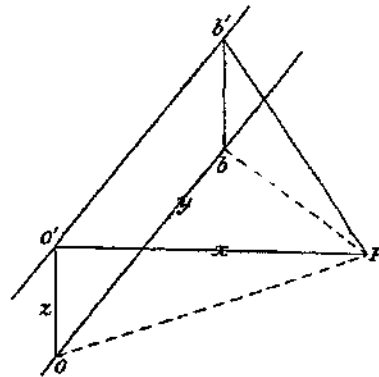

FIG. 3.

<sup>1</sup> It is also probable that the vibrations sent out from each point are regular only for a very short time. These considerations lead to the conclusion, that no places on the earth's surface experience a low intensity of disturbance on account of the interference of vibrations; for altho the interference might exist at a particular moment, the irregularity of the motion would only allow it for a very short time; and the intensity ascribed to a particular place is the maximum intensity which is felt there at any part of the shock. On the other hand, it is quite possible for strong vibrations from two parts of the fault-plane to combine and cause unusual intensity along a particular line or zone. No definite instances of this, however, can be cited in the case of the California earthquake.

<sup>2</sup> Publications of the Earthquake Investigation Commission in Foreign Languages, No. 4.

dies down inversely as the square of the distance; the energy at  $P$  is, therefore, proportional to

$$\frac{B}{I} \int_{-x}^{+x} \frac{dy}{\sqrt{D^2 + y^2}}$$

where  $D$  is the depth of the fault. The limits of the integral along the fault assume an infinite length for the fault; but the result is practically the same if the angle between two lines drawn from the ends of the fault to  $P$  is nearly  $180^\circ$ ; that is, if the distance of  $P$  from the fault is small compared with its length. The values of  $\sqrt{\tan^{-1} \frac{D}{x}}$  have been plotted in fig. 4 in terms of  $\frac{x}{D}$ . It will be noticed it is a function of  $\frac{x}{D}$  and is independent of the actual intensity of the disturbance at the fault-plane; but unlike Major Dutton's energy curves, there is no point of inflection in our curve (this is due

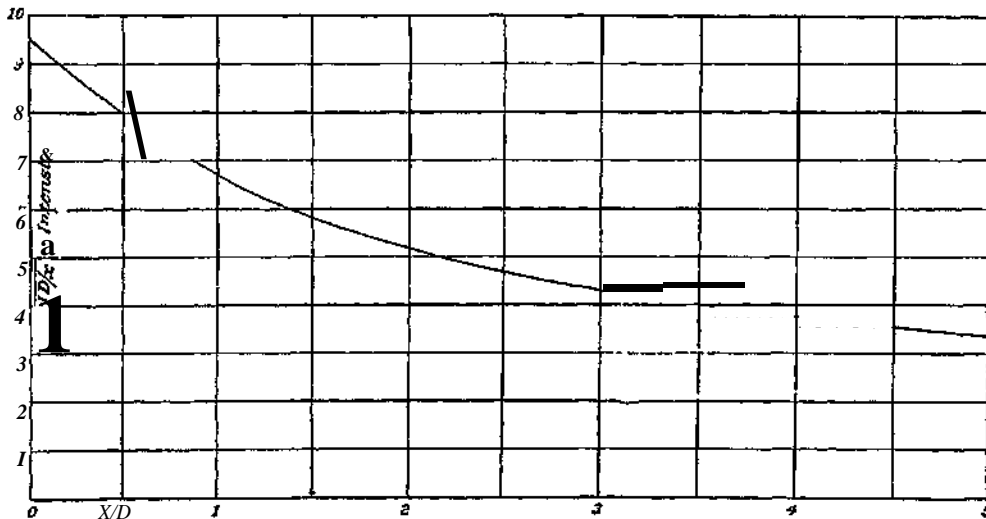

FIG. 4.

to the fact that the fault-plane is not confined to a considerable depth, but extends to the surface of the earth). We must therefore, to determine the depth of the fault, determine the distance of the point where the force bears some definite proportion to the force in the immediate neighborhood of the fault-plane, for instance, where it is half as great. We find from the curve that the distance of this point is about 2.5 times the depth of the fault. We must, now, from our map of intensities determine the actual distance from the fault-plane of the points where the force had diminished to half its value at the fault-line. Professor Omori \* has estimated that the acceleration on the made ground in San Francisco was somewhat less than 2,500 millimeters per second per second, and therefore the acceleration on rock at the fault-plane may be taken at about this value. According to Professor Omori's scale, a force about half as great, or 1,200 millimeters per second per second, corresponds to the degree VIII of the Rossi-Forel Scale, and this isoseismal occurs at a distance of about 20 km. from the fault-line opposite Point Arena; 20 km. is therefore 2.5 times the depth of the fault, which accordingly becomes 8 km. We must not attach too much importance to this result; the assumptions and the data are all too inaccurate, but we can accept it as indicating that in the neighborhood of Point Arena the fault could hardly have extended to a greater depth than 20 km. and probably was not so deep. The distribution of isoseismals north of

<sup>1</sup> Bull. Imperial Earthquake Investigation Commission, vol. i, No. 1, p. 19.



San Francisco Bay show that this conclusion is applicable to all that part of the fault; but further south the isoseismals, where not greatly affected by soft ground; lie close to the fault, indicating a smaller depth.

Both methods of determining the depth of the fault agree in indicating that it is comparatively shallow; the only considerations opposing this are: its length, its comparative straightness, its independence of the topography, which it seems to have controlled rather than to have followed, and the very considerable geologic time which has elapsed since movements were first inaugurated along the rift (vol. i, pp. 48-52). All these facts undoubtedly suggest great depth, but our ignorance of the causes leading to the fault movements makes us attach greater weight to the more definite conclusions already arrived at, and to regard the movement of April 18, 1906, as comparatively shallow. It is the general belief of geologists that fractures of the rock are confined to a crust of small thickness; Professor Van Hise estimates that about 12 km. is the greatest depth to which they can reach, and he bases this estimate on the consideration that the weight of the overlying rock is sufficient at that depth to prevent the formation of cracks or crevices. He writes: "In rocks which were bent when so deeply buried that cracks or crevices could not form even temporarily, it is probable that the material flowed to its new position quietly, without shock, under the enormous stress to which it was subjected."\* But this is not a sufficient criterion; rock can fracture by shearing without the formation of crevices just as a block can slide on a second one without separating from it; in the case of the California earthquake there is no necessity for believing that the two sides of the fault did not always remain in contact while they were slipping past each other, and, as is pointed out further on, the movement near the ends of the fault is taken up by elastic or plastic distortion.

The temperature increasing with the depth increases the plasticity of the rock, but the increasing pressure increases its rigidity to a greater extent, at least for forces like those due to elastic vibrations and the tides of short periods, which do not continue to act for a very long time in the same direction; but for long-continued forces in the same direction, provided they do not increase too rapidly in intensity, the plasticity probably allows slow deformation and prevents the forces from ever reaching the ultimate strength of the rock.

The question which must be answered to determine the depth to which fractures can occur is: At what depth does the plasticity of rock become sufficient to enable it to yield to the stress-difference, which may exist there, rapidly enough to prevent this stress-difference from reaching the ultimate strength of the rock? Unfortunately we do not know any of the elements of the problem, neither the plasticity of the rock as dependent on pressure and temperature, nor the rate at which stress-differences accumulate at distances below surface. It is probable that the point at which a fracture first occurs is not the lowest point to which it extends; for when the break comes, the forces are suddenly transferred to nearby points, and thus the fracture may be carried to depths where no fracture would take place otherwise.

There is very little observational evidence bearing on the question we are discussing. The Appalachian Mountains are characterized in Pennsylvania by open folds and few faults; as we follow the range to the southwest the folds become closer and the faults increase, and in Tennessee, North Carolina, Georgia, and Alabama, the faulting becomes excessive. Mr. Bailey Willis has pointed out<sup>3</sup> that the thickness of the sediments above the Cambro-Silurian limestone was about 23,000 feet (7,000 meters) in Pennsylvania, 10,000 feet (3,000 meters) in southwestern Virginia, and only 4,000 feet (1,200 meters) in Alabama; and he thinks the differences in folding and faulting are due to the differences of the loads when the deformations took place. This indicates that faults are very shallow.

---

<sup>1</sup> Principles of Pre-Cambrian Geology, 16th Ann. Rep. U. S. Geol. Surv., 1894-95, pp. 593-595.

\* Mechanics of Appalachian Structure, 13th Ann. Rep. XL S. Geol. Surv., 1891-02, p. 269.



the western side and the compression on the eastern side. There may have been a more or less irregular distribution of compressions and extensions along the course of the fault due to differences in the amount of the movement, but these, according to Dr. Hayford, are slight except in the region just south of San Francisco. The question arises: How were these compressions and extensions taken up? Did the volume remain constant and the density change; or did the density remain constant and the volume change; or did both changes occur? We have not sufficient evidence to answer this question; but the general properties of matter would indicate that both changes occurred. To the north of San Francisco Bay there seems to have been, in places, a very slight elevation of the land west of the fault, and the only satisfactory explanation so far offered of the action of the tide-gage at Fort Point (described in vol. i, pp. 367-371) indicates a small depression of the west side of the fault opposite the Golden Gate. It is not impossible, altho it is by no means clearly indicated, that the slight elevation of the western side along the northern part of the fault may be due to an increase in volume there, and that the probable depression opposite the Golden Gate may be due to a decrease in volume, which must have taken place in that region, on account of the smaller displacement just south of it.

Returning now to the curving of former straight lines at right angles to the fault as shown in fig. 5, the first analogy suggested by the lines is that of a bent beam. If a beam, which is long in proportion to its thickness, is supported at one end and a weight hung from the other, the beam bends into a curve very much like that shown in the figure; the under, concave surface is compressed; the upper, convex surface is stretched; and between the two there is a neutral plane which is neither compressed nor stretched. But when the thickness of the beam is great in comparison with its length, the distortion is due to the elastic shear of each layer over its neighbor. In this case the thickness of the beam would be 435 km. (270 miles) and the length probably less than one-twentieth as much; so that the distortion must have been due to shear and not to bending in the ordinary sense of the word.

#### THE NATURE OF THE FORCES ACTING.

We know that the displacements which took place near the fault-line occurred suddenly, and it is a matter of much interest to determine what was the origin of the forces which could act in this way. Gravity can not be invoked as the direct cause, for the movements were practically horizontal; the only other forces strong enough to bring about such sudden displacements are elastic forces. These forces could not have been brought into play suddenly and have set up an elastic distortion; but external forces must have produced an elastic strain in the region about the fault-line, and the stresses thus induced were the forces which caused the sudden displacements, or elastic rebounds, when the rupture occurred.<sup>1</sup> The only way in which the indicated strains could have been set up is by a relative displacement of the land on opposite sides of the fault and at some distance from it. This is shown by the northerly displacement of the Farallon Islands of 1.8 meters between the surveys of 1874-1892 and 1906-1907, but the surveys do not decide whether this displacement occurred suddenly at the time of the earthquake, or grew gradually in the interval between them; there are valid reasons, however, for accepting the latter alternative, as the following considerations show: The Farallon Islands are far beyond the limits of the elastic distortion revealed by the surveys, so that we can not ascribe their displacement to elastic rebound; and we have seen that this is the only kind of force which could have produced a sudden movement; and what

<sup>1</sup> We use the words *strain* and *stress* as they are used in the theory of elasticity. A *strain* is an elastic change of shape or of volume caused by external forces; and a *stress* is a resisting force which the body opposes to a strain, and with which it tends to diminish it.

is still more convincing, we shall shortly see that not only was the displacement of 1.8 meters of the Farallons between the survey of 1874-1892 and 1906-1907 insufficient to account for the slip on the fault, but the additional displacement of 1.4 meters which they experienced between the surveys of 1851-1865 and 1874-1892 leaves this quantity still too small.

We must therefore conclude that the strains were set up by a slow relative displacement of the land on opposite sides of the fault and practically parallel with it; and that these displacements extended to a considerable distance from the fault. Let us consider this process; suppose we start with an unstrained region, fig. 6, in which the line  $AOC$  is straight; suppose forces parallel to  $B''D''$  to act on the regions on opposite sides of the line  $B''D''$  so as to displace  $A$  and  $C$  to  $A''$  and  $C''$ ; the straight line  $AOC$  will be distorted

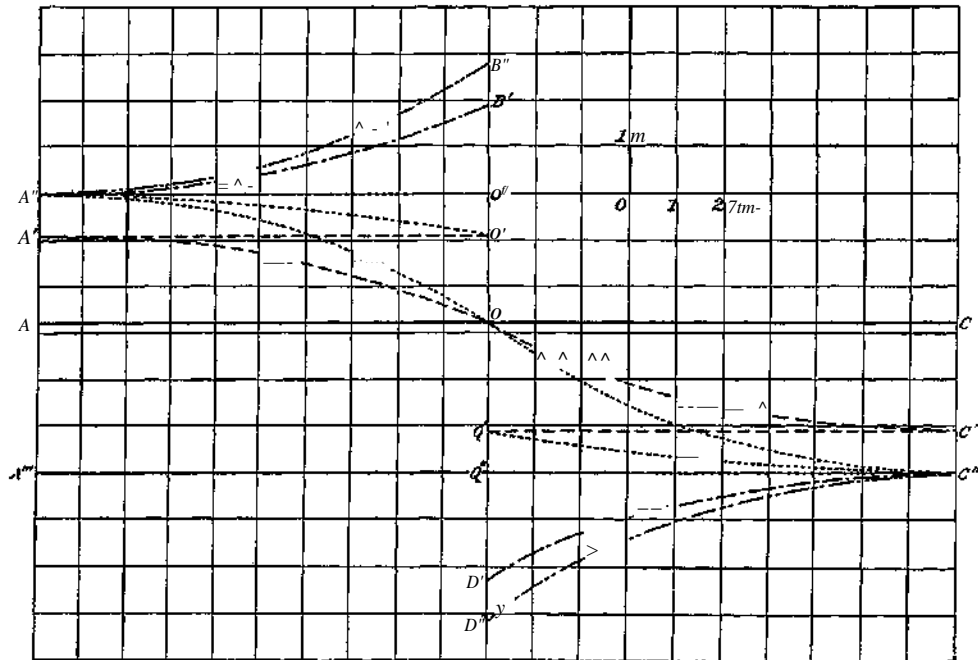

FIG. 6.

into the line  $A''OC''$ ; if the distortion is beyond the strength of the rock, a rupture will occur along  $B''D''$ ; the line  $A''OC''$  will be broken and the two parts will become straight again and will take the positions  $A''O''$  and  $C''Q''$ ) and  $O''Q''$  will represent the relative slip at the line of rupture, which will be equal to  $A''A''$ , the sum of the opposite displacements which  $A$  and  $C$  gradually experienced when they were brought to  $A''$  and  $C''$ . All points on the western face of the fault will move a distance  $OO''$  to the north, and all points on the eastern face a distance  $OQ''$  to the south. The straight line which occupied the positions  $A''O''$  and  $O''Q''$  just before the rupture will be distorted to  $A''B''$  and  $C''L''$ , these lines being exactly like  $A''O$  and  $CO$ , but turned in opposite directions. The sum of  $O''B''$  and  $Q''B''$  will exactly equal  $O''Q''$ , the total slip.

When we examine the actual displacements about the fault-line, we find that the slip  $B''D''$ , fig. 5, about 6 meters, is fully 4 meters greater than the relative displacement of  $A''$  and  $C$  since the survey of 1874-1892; this means that the region was not unstrained at that time, but that  $A'$  and  $C$  had already suffered a relative displacement of about 4 meters from their unstrained positions; that is, two-thirds of the stress which caused the rupture had already accumulated 25 years ago. Going still further back to the surveys of 1851-1865, we find that the total relative displacement of distant points on

opposite sides of the fault since that date amounts to about 3.2 meters, a little more than half enough to account for the slip on the fault-plane; therefore 50 years ago the elastic strain, which caused the rupture in 1906, had already accumulated to nearly half its final amount. It seems not improbable, therefore, that the strain was accumulating for 100 years, altho there is no satisfactory reason to suppose that it accumulated at a uniform rate.

We can picture to ourselves the displacements and the strains which the region has experienced as follows: let  $AOC$  (fig. 6) be a straight line at some early date when the region was unstrained. By 1874-1892,  $A$  had been moved to  $A'$  and  $C$  to  $C'$ , and  $AOC$  had been distorted into  $A'O'C'$ ; by the beginning of 1906,  $A$  had been further displaced to  $A''$  and  $C$  to  $C''$ , the sum of the distances  $AA''$  and  $CC''$  being about 6 meters; and  $AOC$  had been distorted into  $A''O'C''$ . When the rupture came, the opposite sides of the fault slipped about 6 meters past each other;  $A''O$  and  $C''O$  straightened out to  $A''O'$  and  $C''Q'$ ; and the straight lines which occupied the positions  $A'O'$  and  $C''Q'$  just before the rupture, were distorted afterward into the lines  $A''B''$  and  $CD''$ , these lines being exactly like the lines  $A''O$  and  $C''O$  but turned in opposite directions. The straight lines, which occupied the positions  $A^fO'$  and  $C^fQ'$  in 1874-1892, were distorted into  $A''O'$  and  $C''Q'$  in the beginning of 1906; at the time of the rupture their extremities on the fault-line had the same movements as other points on that line;  $O'$  moved to  $B^f$  and  $Q'$  to  $D'$ . If we should move the left half of our figure so as to make  $A'O'$  continuous with  $C^fQ'$ , fig. 6 would then be practically similar to fig. 5 and similar letters in the two figures would refer to the same points; in fig. 5, however, we have supposed  $C$  to remain stationary and have attributed all the relative movement to  $A'$ , whereas in fig. 6 we have divided the movement equally between  $A^f$  and  $C''$ ; as we do not know the actual, but only the relative, movement this difference has no significance.

What was actually determined by the two surveys were the distances of points on the line  $C^fD'$  and  $A''B''$  in fig. 5 measured from the line  $C'A'$ ; and this is equivalent in fig. 6 to the distances of the line  $C''D'$  from  $C''Q''$ , and  $A''B''$  from  $Q'A''$  less the distance  $O'Q'$ . The divergence of the lines  $A''B''$  and  $CD'$  from straight lines does not represent the strains which existed in the region just before the rupture, but only the strains accumulated before 1874-1892; we have seen that the total strains set up by 1906 are represented by the divergence from straight lines of the lines  $A''O$  and  $CO$ , or their counterparts,  $A''B''$  and  $CD''$ .

#### ILLUSTRATIVE EXPERIMENTS.

The following very simple experiments were made to illustrate the conclusions we have arrived at regarding the elastic strains and the relations between the slip at the fault-plane and the displacements of distant points. A sheet of stiff jelly about 2 cm. thick and 4 cm. wide was formed between two pieces of wood (fig. 7) to which it clung fairly well. A straight line  $AC$  was drawn on the jelly, which was then cut by a sharp knife along the line  $ttf$ ; the left piece of wood was then moved about 1 cm. parallel with  $ttf$ , as shown in fig. 8; a slight pressure on the jelly prevented slipping along the cut line; the jelly was thus subjected to an even shear thruout and the original straight line  $AC$  was distorted into the line  $A''C$ ; when the pressure on the jelly was removed, the elastic stresses set up by the distortion came into action, the two sides of the jelly slipped past each other along the line  $\ll'$ ,  $A''O$  straightened out to  $A^*O$ , and  $CO$  to  $CQ$  the slip  $Q^*O''$  being equal to the distance  $AA''$ ; and all the strain in the jelly was relieved. (The difference in the straight line  $A^fOC$  in the jelly and the curved line  $A^*OC$  (fig. 6) in the rock will be explained later.)

A second straight line  $A^*CC$  was drawn across the jelly after  $A$  had been displaced, but before it was allowed to slip on the line  $ttf$ ; when the slip took place, this line broke

at  $O''$  and took the position  $A''B''$  and  $CD''$ ; the slip  $D''B''$  equaled the displacement  $AA''$ ; but the points  $A''$  and  $C''$ , of course, remained unmoved.

A third experiment was made. A line  $A'C$  (fig. 9) was drawn after the jelly had been distorted, exactly as in the last experiment; the left piece of wood was then moved 0.5 cm. further and the line was distorted into  $A''C$ ; when the jelly slipped and resumed

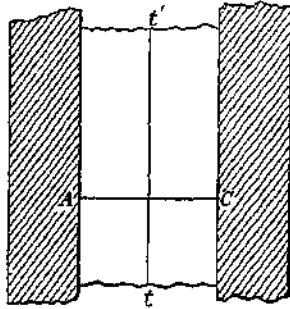

FIG. 7.

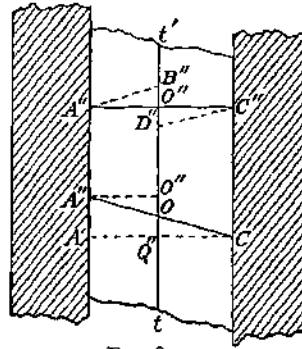

FIG. 8.

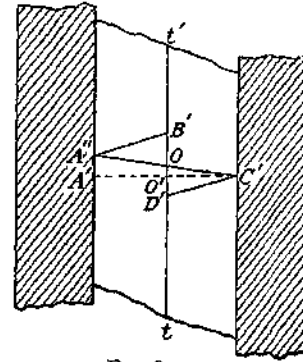

FIG. 9.

its unstrained position, the line  $A''OO$  broke into the two lines  $A''B'$  and  $CD'$ ; the slip  $D'B'$  was 1.5 cm., equal to the total displacement of the left piece of wood from its original position when the jelly was unstrained; and the distances of points on the line  $A''B'$  near the fault, measured from the line  $A'C$ , were about twice the distances from  $A'C$  of points on the line  $CD'$  at equal distances from  $tt'$ . But at a distance from  $tt'$  the displacements on the left were more than twice as great as those on the right; which agrees with the relative displacements actually observed (vol. I, p. 134). With the exception of the straightness of the lines the last experiment reproduces exactly the characteristic movements which took place at the time of the California earthquake. The letters in figs. 7, 8, and 9 correspond to those in figs. 5 and 6.

#### THE INTENSITY OF THE ELASTIC STRESSES.

The forces which caused the rupture at the fault-plane are measured by the distortion of the rock there, and if we can determine the angles which the lines  $A''O$  and  $CO$  (fig. 6) make with  $AC$  at  $O$ , we can estimate these forces; these angles can be determined approximately from the analogous angles at  $B'$  and  $D'$ . Let us determine what the latter angles are. The lines  $A''B'$  and  $C'D'$  are constructed from Dr. Hayford's summary of the results of the surveys already mentioned and have the same curvature as the lines  $A''B'$  and  $CD'$  in fig. 5; the data (vol. i, p. 133) may be collected in a table as follows:

TABLE 3. — Displacements between II and III Surveys.

No. OF POINTS.	AVERAGE DISTANCE FROM FAULT.		DISPLACEMENT BETWEEN II AND III SURVEYS.	
	East.	West.	South.	North.
	km.	km.	m.	m.
10	1.5	....	1.54	....
3	4.2	....	0.86	....
1	6.4	....	0.58	....
12	...	2.6	....	2.05
7	...	5.8	....	2.38
1	:::	37.0	....	1.78

It will be observed that three points are determined on the eastern line near enough to the fault to enable us to draw the line fairly well and to extend it to the fault at  $D'$  (fig. 5). We have but two points determined on the western line near the fault, which are not enough to determine the character of the line; but a third point is determined from the fact that  $B'$  must be about 6 meters from  $D'$ , and we can therefore draw the western line fairly well also. Its general form is like that of the eastern line, but its curvature is somewhat less. This is probably in part due to the fact that the rocks on the western side of the fault are more rigid than those on the eastern side; for former movements on this fault have raised the western side relatively to the eastern and brought the more rigid crystalline rocks nearer the surface.

In fig. 6  $B'B'' = O'O'' = 0.9$  meter, that is, half of 1.8 meters, the total relative displacement of  $A'$  and  $C''$  between the two surveys; and since  $O''B''$  is a little less than half the total slip, on account of the greater rigidity of the western rocks, we may estimate it at 2.8 meters. Therefore  $CW$  equals 1.9 meters, and  $O''B''$  is 1.47 times  $O''B'$ ; and since the curves  $A''B'$  and  $A'B''$  are both curves of elastic distortion of the same substance the angle at  $B''$  must be 1.47 times that at  $B'$ . We can measure the angles at  $B'$  in fig. 5 and we find it  $1/2,500$ ; therefore the angle at  $B''$  is  $1/1,700$ ; similarly we find the angle at  $D''$  to be  $1/1,000$ .

We can determine the force necessary to hold the two sides together before the rupture, which must exactly have equaled the stress which caused the break. The force per square centimeter is given by the expression  $ns$  where  $n$  is the coefficient of shear and  $s$  is the shear, measured by the angle at  $\theta$  or  $B''$  for the western side of the fault, or the angle at  $O$  or  $D''$  for the eastern side. We shall see further on that in the crystalline rocks below the surface the strain was somewhat greater than at the surface, so that we may assume that the angle corresponding to  $B''$  lower down may be as high as  $1/1,500$ .

The experiments of Messrs. Adams and Coker<sup>2</sup> give the value of  $n$  for granite as  $2 \times 10^{11}$  dynes per square centimeter (2,900,000 pounds per square inch); therefore the force necessary to produce the estimated distortion at the fault-plane at a short distance below the surface is  $1/1,500$  of this, or  $1.33 \times 10^8$  dynes per square centimeter (1,930 pounds per square inch). There are no very satisfactory determinations of the strength of granite under pure shear; tests made at the Watertown Arsenal<sup>3</sup> gave values ranging between about  $1.2 \times 10^{11}$  and  $1.9 \times 10^{11}$  dynes per square centimeter (between 1,700 and 2,900 pounds per square inch), but these values are apparently too small, for the specimens were subjected to tensions and compressions as well as to shear. The rock at a distance below the surface would probably have a greater resistance to shear on account of pressure upon it, and moreover it has not been subjected to the changes of temperature, etc., which the surface rocks experience, so that it probably has a strength greater than the higher figure given. We must therefore conclude that former ruptures of the fault-plane were by no means entirely healed, but that this plane was somewhat less strong than the surrounding rock and yielded to a smaller force than would have been necessary to break the solid rock. This idea is strongly supported by a comparison of the distance to which this shock and the earthquake of 1886, at Charleston, South Carolina, made themselves felt. With a fault-length of 435 km. (270 miles), the California earthquake was noticed at Winnemucca, Nevada, a distance of 550 km. (350 miles) at right angles to the fault; whereas the Charleston earthquake, with a fault-line certainly less than

<sup>1</sup> This reasoning is not perfectly rigid; the similarity of the lines  $A''B'$  depends upon the similarity of strains set up during the intervals between the I and 1% and the II and III surveys. These were probably fairly similar, as the difference between them represents the strain added between the II and III surveys which was only a fraction of the total strain at the time of the break; and the results obtained upon this assumption can not be very far wrong.

<sup>2</sup> An Investigation into the Elastic Constants of Rocks. Frank D. Adams and Ernest G. Coker, Carnegie Institution of Washington, Publication No. 46, 1900.

<sup>3</sup> Report of Tests of Metals, etc., made at the Watertown Arsenal, 1890, 1894, 1895. Washington, D.C.

40 km. (25 miles) long was felt slightly in Boston, a distance of 1,350 km. (850 miles). If we assume that the vibrations from the two disturbances had about the same periods and that a certain acceleration is necessary for a shock to be felt, we find that the amplitude of the vibration must have been about the same at Boston and at Winnemucca, for the two shocks, respectively; as the amplitude would diminish inversely as the distance for the Charleston earthquake, but much more slowly for the California earthquake on account of the length of the fault-line, the amplitude of the former disturbance must have been many times as great as that of the latter at the same distance from the origin; and the intensity must have been very many times greater per unit area of the fault-plane for the Charleston earthquake than for the California earthquake.

The above calculation of stresses applies especially to the region north of San Francisco; to the south the slip at the fault-line was, in places and perhaps for all this part of the fault, somewhat smaller. At Wright the slip on the fault-plane in the tunnel is given by the engineers as 5 feet, and the west side was shifted toward the north (vol. i, fig. 42, and pp. 111-113). This is a case of elastic rebound as at other parts of the fault. The character of the material in the tunnel and the numerous cracks in the surrounding mountain, one of which shows a relative shift opposite to that generally observed (p. 35), lead us to expect more or less irregularity in the distortion of the tunnel, which is confirmed by the figure. The greatest angle of shear must be something more than half the slip at the fault-plane divided by the distance over which the distortion is distributed; this gives  $2.5/5,150$  or  $1/2,000$ , approximately. The angle of distortion is apparently slightly less here than further north. The smaller slip in the neighborhood of Colma, a little south of San Francisco, may be due to the partial relief of strain by the earthquake of 1868; for it shows that this region was under less strain at the time of the II survey than the region further north.

#### THE WORK DONE BY THE ELASTIC STRESSES.

We can also determine the work done at the time of the rupture; it is given by the product of the force per unit area of the fault-plane multiplied by the area of the plane and by half the slip. If we take the depth of the fault at 20 km. (12.5 miles), the length at 435 km. (270 miles), the average shift at 4 meters (13 feet), and the force at  $1 \times 10^8$  dynes per square centimeter (1,450 pounds per square inch), we find for the work  $1.75 \times 10^{24}$  ergs ( $1.3 \times 10^{17}$  foot-pounds), or 130,000,000,000,000,000 foot-pounds.<sup>1</sup> This energy was stored up in the rock as potential energy of elastic strain immediately before the rupture; when the rupture occurred, it was transformed into the kinetic energy of the moving mass, into heat and into energy of vibrations; the first was soon changed into the other two. When we consider the enormous amount of potential energy suddenly set free, we are not surprised, that, in spite of the large quantity of heat which must have been developed on the fault-plane, an amount was transformed into elastic vibrations large enough to accomplish the great damage resulting from the earthquake and to shake the whole world so that seismographs, almost at the antipodes, recorded the shock.

#### THE DISTRIBUTION OF THE DEFORMING FORCES.

In examining what forces could have caused the slow displacements which brought about the strains existing in the region before the rupture, we note that gravity does not seem to have been directly active, as the displacements were practically horizontal. Any force except gravity could only have been applied to a boundary of the region

<sup>1</sup> It is probable that the maximum strain was not produced at all parts of the fault-plane, and especially not near its ends; but when the rocks broke at one place, the stress was thrown upon adjacent parts and the fracture thus carried along; in this way the fault was probably made much longer than it would otherwise have been. This consideration leads us to put the maximum stress at three-quarters the value determined from the distortion of the rock.



moved. There is no direct evidence that forces brought into play by the general compression of the earth thru cooling or otherwise were involved, for there is no evidence that the surface of the earth was diminished by the fault. It is true that the surveys did not extend over the whole length of the fault, and therefore are not decisive on this point, but so far as they went they show an extension of the region between San Francisco and Monterey Bay, between the surveys of 1851-1865 and 1906-1907.

A strong, shearing force would be produced along the fault-plane by forces making an angle in the neighborhood of  $45^\circ$  with it; that is, by either tensions or compressions in directions roughly north and south or east and west, or by a combination of the two. A tension alone could not have caused the rupture, for then the sides would have been pulled apart; an east-west compression would have brought Mount Diablo and the Farallon Islands nearer together and would have reversed the observed relative movements on opposite sides of the fault. The surveys, altho not entirely decisive, are against a north-south compression; and, moreover, the elastic distortion accompanying a compression which could produce a fracture 435 km. long would not have been restricted to a zone extending only 6 or 8 km. from the fault-plane. A shear exerted by forces parallel with the fault-plane on the eastern and western boundaries (which is equivalent to a north-south compression and an east-west tension at the boundaries) with no resistance at the under surface would have produced an even shearing strain thruout the region between them; and straight lines would have been changed into other straight lines, exactly as occurred in the experiments described above and illustrated in figs. 8 and 9. An additional compression or tension in any direction would not have altered this characteristic. Similar forces on the eastern and western boundaries with forces at the under surface resisting the movements would have produced some such distortion of the straight line  $AC$  into  $A'O$  as shown in fig. 10. The tendency to rupture would be greatest at  $A'$  and  $C''$  and least in the neighborhood of  $O$ ; it is evident that such forces could not have produced a rupture at  $O$ , and the displacements are not like the displacements observed.

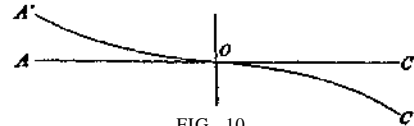

FIG. 10.

The only other boundary is the under surface of the moved region, and it is here that we must suppose the disturbing forces applied; and they must be distributed over this surface so as to produce the distortions observed.

NOTE. — Mr. Gilbert has suggested a modification of the experiments described above; instead of making the cut, which represents the fault, all the way thru the jelly, he suggested that it extend only a part way thru, and that it would thus more nearly represent the true conditions of the earthquake fault. This was tried, but the jelly was not strong enough to resist the forces developed during the displacement and the break was quickly extended all the way thru the jelly. It is not difficult, however, to see what forces would be developed under these circumstances. There are two cases: first, suppose\*there exists below the crust a region practically devoid of elasticity, in which only viscous forces can act, and suppose the fault extends to this region; we then come back to the last case considered. Second, suppose the elastic character of the rock extends well below the lower limit of the fault; such a case could easily exist if the strength of the rock increased with depth, even tho the strains continued far below the fault as great as they were within its limits. Let us consider the nature of the distortion produced in this case. We shall suppose the rock under elastic shearing strain, and when the rupture occurs, the shearing forces across the fault-plane, which upheld the strain, are annulled and the rock takes a new position of equilibrium under the new forces brought into action, in such a way that the surface line  $A'OC$  (fig. 11), straight just before the rupture, afterwards takes the position  $A'O', D'C$ . Below the limit of the fault no change takes place, but the original vertical plane thru  $A'O'C$  has been broken and warped, suffering no displacement below the fault, but gradually increasing its distortion until it corresponds to  $AO'$  and  $D'C''$  at the surface.

An element of the surface  $a$ , on the eastern side of the fault, has been displaced to  $a'$  and a vertical line,  $a''a$ , thru  $a$  has been distorted into  $a''a'$  by an elastic shear. The forces parallel with the fault acting on the element in its new position are:

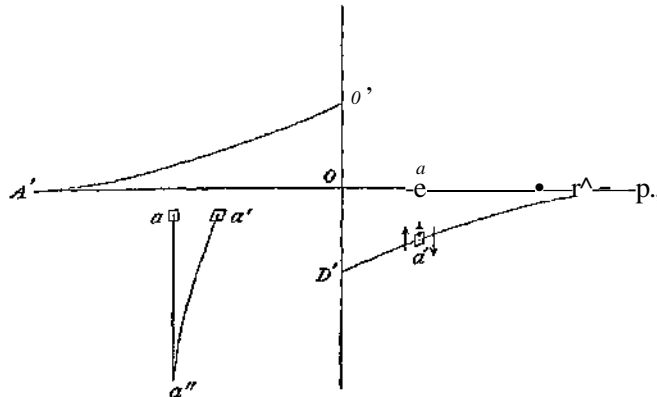

FIG. 11.

a shearing force to the south-east on its northeastern face, one to the northwest on its southwestern face, one to the north-west on its under surface due to the shear in the vertical plane; for equilibrium the sum of these must be zero, therefore the shearing force on the northeastern face must be greater than that on the southwestern; this relation holds for the whole length of the line  $D'C$ ; the shearing stresses therefore must become greater as we leave the fault-line. As the strains are proportional to the stresses, the curvature of the line  $D'C$  must become greater

the further we go from the fault, until we reach the boundary where the forces are applied. This is true whether the forces are tangential forces applied along a boundary parallel with the fault, or a general north-south compression and an east-west tension. The surveys, however, on the east side of the fault, where alone they are sufficiently complete, show that the curvature of the distorted line was greatest near the fault-line; they could not, therefore, be due to a general compression and extension nor to simple tangential forces, but the distorting forces must diminish with distance from the fault-line; this could only hold if they were applied at the under surface, which brings us back to the conclusion already reached.

Let us suppose the straight line  $WOE$  in fig. 12 to represent a line at right angles to the fault in the unstrained condition; let this line be slowly distorted by the applied forces into the full line  $WAOCE$  just before the rupture. We have heretofore only considered the region between  $A$  and  $C$ , that is, between Mount Diablo and the Farallon Islands, but we now extend our consideration to the whole region moved. It is evident that the displaced

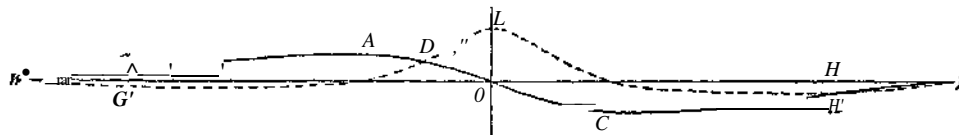

FIG. 12.

area must have some limit; the surveys only covered the region between  $A$  and  $C$ , and therefore throw no light on what occurred at greater distances from the fault. There is no reason whatever to believe that other ruptures and slips occurred outside the region between  $A$  and  $C$ ; there is a gradual diminution of the intensity of the felt disturbance as the distance from the fault increases, with the exception of the Sacramento Valley, where the slight increase is entirely accounted for by the alluvial character of the ground, thus indicating that the whole disturbance originated in the one fault. The great intensity in the San Joaquin Valley may possibly be due to a local rupture; but this lies only opposite to the southern part of the great fault and does not affect the general argument, which is especially applicable to the region north of San Francisco. We conclude therefore that the displacement gradually dies out to the west of  $A$  and to the east of  $C$ , tho it may continue for a very great distance; and we assume that the line of displacement becomes asymptotic to the undisturbed line  $WOE$  at some distant points,  $W$  and  $E$ , which would be characteristic of any displacement gradually dying out. The shearing force at any point of this line is proportional to the shear, which equals the angle at that

point which the line makes with its original unstrained direction. We have represented the value of this force by the broken line  $WG'LH'E$  in fig. 12. Starting at  $W$  where it is zero, the shearing force becomes negative; that is, it is directed in a southerly direction, reaching a negative maximum at  $G'$ , where the displacement curve has a point of inflection; it then diminishes in value, becoming zero at  $A$ , where the displacement curve is parallel with its original direction; it then increases rapidly in value, reaching a positive maximum,  $L$ , at  $O$ , the point of rupture; the shearing force to the east of the rupture has somewhat the same value it has at an equal distance to the west, tho symmetry is not required. The total shearing force which we have determined is not the force applied at each point under consideration, but is equal to the sum of all the forces applied to the east or west of the point; the actual force applied at each unit length of the line is proportional to the difference in value of the total shearing force at points a unit distance apart; that is, to the angle which the line representing the total shearing force makes with the line  $WOE$ ; it is represented by  $WGDOFHE$  in fig. 13. Starting with a zero value at  $W$ , it first has a small negative value but becomes zero again at  $G$ ; it then becomes positive and increases to a maximum at  $D$ , where the line of total shear has a point of inflection—and dies down rapidly to zero at  $O$ , where the total shear is a maximum; it has somewhat similar but opposite values to the east of  $O$ .

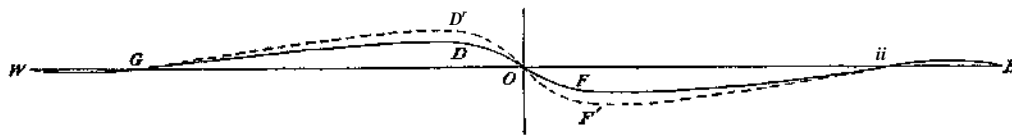

FIG. 13.

Without insisting on accuracy in small details the full line in fig. 13 shows in a general way the relative distribution of the forces, applied at the under side of the moved region, which brought about the California earthquake.

The distribution of the total shearing forces shows why in 1906 there was no break at the Haywards fault, where the break occurred which caused the earthquake of 1868. This fault is about 30 km. (18.5 miles) east of the San Andreas fault; and therefore in the neighborhood of  $C$  (fig. 12), where the surveys detected no displacement relative to Mount Diablo; in this region, as the figure shows, there was practically no shearing force, and therefore no break occurred. For the same reason there was no rupture at the San Bruno fault south of San Francisco. This fault is 4 km. (2.5 miles) east of the San Andreas fault and at that distance (fig. 5) the shearing force was only about one-third as strong as it was where the rupture actually occurred. We have seen that the elastic strain was probably accumulating for 100 years; it is quite possible, then, that the earthquake of 1868 partially relieved the strain for some distance south of San Francisco and that there would have been no fracture in this part of the San Andreas fault if additional strains had not been thrown on it by the rupture of the fault-plane further north.

It is to be noticed that the distances from  $O$  to  $A$  and from  $O$  to  $C$ , beyond which no distortion of the rocks occurred, were probably less than 10 km. (6 miles), and the distances  $OG$  and  $OH$ , over which the distorting forces were distributed, were probably ten or more times as great, and the total area over which they were applied was many times as great as the area of the fault-surface; the applied forces were therefore considerably smaller per unit area than the shearing forces at the fault; for the sum of all these forces on each side of the fault-plane must have equaled the shearing force at that plane plus the small shearing force at  $G$  or  $H$ , due to the slight reverse curving at this point.

As the dragging forces are applied at the base of the crust they have a moment about its center of gravity which is balanced by the moment due to stronger and greater shears near the bottom than near the top at the points  $G$ ,  $O$ , and  $H$  (fig. 12); and lines at differ-

ent distances below the surface which were straight and at right angles to the fault when the rock was unstrained became distorted in different degrees, the distortion from the surface downwards being somewhat as shown in fig. 14; where the three lines illustrate,

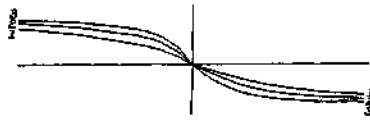

FIG. 14.

in an exaggerated way, how the distortion of straight lines varies from the surface (1) to the bottom (3). Both the shearing strain and the strength of the rock increase with the depth, but the rate of neither is known; the depth at which the rupture first occurs is the depth at which the shearing strain becomes too great for the rock to withstand. It is pretty certain that this would not be very near the surface, and also that it would not be at the lowest part of the subsequent fault, but somewhere between those two points; for, wherever the rupture began, the strain must have been increased on all sides, the fracture must have been extended downwards as well as in other directions, until the strain was generally relieved. The determination, by time observations, of the origins of the earliest disturbance and of the beginning of the heavy shock place them between the surface and a depth of 40 km. (25 miles).

#### THE DISTRIBUTION OF THE SLOW DISPLACEMENTS.

We have no information regarding the absolute displacements of the land at a distance from the fault-line; we merely know that relative displacements occurred between the surveys of 1851-1865 and 1874-1892; and also between 1874-1892 and 1906-1907. We have for the sake of simplicity assumed that the regions at a distance from the fault and

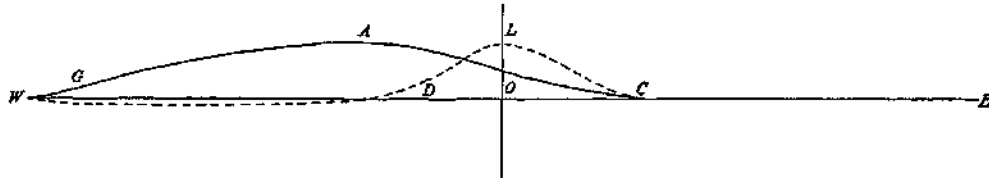

FIG. 15.

on opposite sides experienced nearly equal and opposite absolute displacements; but this is entirely unnecessary. It is possible, indeed probable, that the region on one side of the fault and at a short distance from it remained stationary, and that the slow displacements were all in one direction. The fact that the eastern side was above, and the western side below the sea-level, does not in the least indicate which side remained stationary; but the constancy in length and direction of the line from Mount Diablo to Mocho suggests that the eastern side was not displaced; for it seems improbable that, if this side had moved,

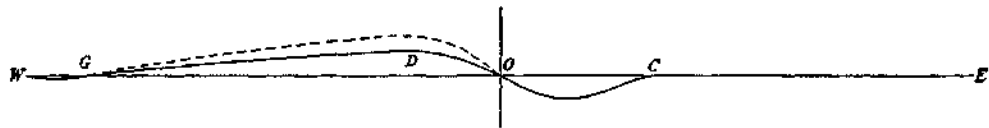

FIG. 16.

the displacements would have been so nearly alike at the points mentioned that no change could be detected in the line joining them. Under this assumption our curve of displacements takes the form of the full line in fig. 15 instead of that in fig. 12. The curvature of this line between A and C is the same as in the former case; to the east of C the line is straight, and at some point to the west of A it again reaches its unstrained position. The total shearing force (represented by the broken line in fig. 15) has practically the same values as in the former case, except that it dies out near C; and the applied forces per unit area (full line in fig. 16) do not differ materially from the former case except that they do not extend farther east than C.

## A POSSIBLE ORIGIN OF THE DEFORMING FORCES.

The reasoning so far has been strictly along dynamic lines and the results may be accepted with some confidence; but in attempting to find the origin of the forces which produced the deformation we have been studying, we pass into the region of speculation.

The theory of isostasy, which has been shown to be true on broad lines by geodetic observations, requires that there be flows of the material at some distance below the surface to readjust the equilibrium destroyed by the erosion and transportation of material at the surface. This suggests that flows below the surface may have been the origin of the forces we have been considering, for as Dr. Hayford has pointed out,<sup>1</sup> such flows would exert a drag on the material above them. The isostatic flows are the direct result of gravity and therefore easily understood, but no explanation has been found for the flows suggested as the origin of the forces in the case under consideration; nevertheless, as the forces must have been exerted at the lower surface of the moved region, it is worth while to determine the character of the flows which could have produced these forces, and leave to future observations the decision as to whether they really exist or not. Without assuming exact proportionality between the flow and the dragging force it exerts, we can say that the flow would be in the same directions as the force and would increase and decrease with it. Therefore the flow can be inferred from the diagram of forces in figs. 13 and 16. In the first case they consist of a flow to the north between  $G$  and  $O$ , and a flow to the south between  $O$  and  $H$ ; they would not be uniform, but starting with a zero value at  $G$  and  $H$ , they would increase to maxima at  $D'$  and  $F'$ , and decrease again to zero at  $O$ . The force between  $W$  and  $G$ ,  $H$  and  $E$ , would not be due to flows but would be due to the resistance to the displacement of that part of the crust by the undisturbed material below; this displacement being due to the drag of the flows nearer the fault, transmitted elastically thru the crust to these regions; this is indicated by the reversed curvature of the line of displacements in fig. 12. The principle of continuity would naturally lead us to suppose that the flows were connected beyond the northern and southern ends of the fault; these portions of the flow would be so far apart and would have so short a length in comparison with the portions flowing north or south that their effects would be relatively insignificant. It may appear that there is a suggestion here of perpetual motion, but this is not so; all steady flows are in closed circuits, and it is only in case we should disregard the necessity of a proper supply of energy, that we should fall into the fallacy of perpetual motion.

The line of demarkation between the northerly and southerly flows need not necessarily lie exactly in the fault-line, but sufficiently near it for the growing shearing force to reach the limiting strength of the rocks at that point before it did at other points; nor is it necessary to suppose that the flows remain either constant in strength or in position; the contrary seems more probable; for if, as is natural to suppose, the forces which caused the earthquakes of 1868 and 1906 were of the same general character, the region of greatest shear, that is, the boundary between the flows, must have been in the neighborhood of the Haywards fault, about 30 km. (18.5 miles) further east, in 1868. Indeed, the displacements which occurred between the first two surveys indicate a somewhat different distribution of the flow from that suggested to explain the later displacements.

At first thought we might suppose that the movement of Mount Tamalpais in opposite directions relative to Mount Diablo in the two intervals between the surveys would indicate that it was on opposite sides of the boundary during these intervals respectively, but this would not necessarily follow. During the whole time that strains were being set up all points west of  $C$  moved to the north with respect to it; this relative movement in the second interval is represented on the eastern side of the fault by the distances between the lines  $CQ^f$  and  $CQ^*$  in fig. 6; and if we consider the curves in the figure as similar

<sup>1</sup>The Geodetic Evidence of Isostasy. John F. Hayford. Proc. Washington Acad. of Sci., 1896\* vol. VII, pp. 25-40.

curves, it can be shown that these distances are a little less than four-tenths the observed distances between  $C''D'$  and  $C''Q''$ , at equal distances from the fault. The observed southerly displacement of Mount Tamalpais between 1874-1892 and 1906-1907 was 0.58 meter; its northerly displacement between 1874-1892 and the beginning of 1906 must have been about 0.22 meter; and therefore its actual southerly movement at the time of the earthquake must have been 0.8 meter; and the opposite displacements of Mount Tamalpais in the two intervals would have occurred independently of the shifting of the underground flows.

If instead of considering the displacements roughly symmetrical and in opposite directions on opposite sides of the fault-line, we prefer to consider that they were all northerly, the conditions are represented in figs. 15 and 16; they are satisfied by the supposition of a single, northerly flow extending for some distance to the west, increasing to a maximum at  $D$  and diminishing rapidly to zero in the neighborhood of  $O$  (broken line in fig. 16). The southern force between  $O$  and  $C$  would be referred to the resistance which the underlying material would offer to the displacement of the crust above it.<sup>1</sup>

---

<sup>1</sup> Mr. Bailey Willis, on account of the forms of the mountain ranges bordering the Pacific Ocean, has concluded that the bed of the ocean is spreading and crowding against the land. He thinks in particular that there is a general sub-surface flow towards the north which would produce strains and earthquakes along the western coast of North America. *Science*, 1908, vol. XXVII, p. 695.

## ON MASS-MOVEMENTS IN TECTONIC EARTHQUAKES.

---

### THE MOVEMENTS BEFORE AND DURING EARTHQUAKES.

The following is the conception of the events leading up to a tectonic earthquake and of the earth-movements which take place at the time of the rupture, as developed by the observations and study of the California earthquake and by the comparison of these observations with what has been observed in other great earthquakes.

It is impossible for rock to rupture without first being subjected to elastic strains greater than it can endure; the only imaginable ways of rapidly setting up these strains are by an explosion or by the rapid withdrawal, or accumulation, of material below a portion of the crust. Both explosions and the rapid flow of molten rock are associated with volcanic eruptions and with a class of earthquakes not under present discussion; since earthquakes occur not associated with volcanic action, we conclude that the crust, in many parts of the earth, is being slowly displaced, and the difference between displacements in neighboring regions sets up elastic strains, which may become greater than the rock can endure; a rupture then takes place and the strained rock rebounds under its own elastic stresses, until the strain is largely or wholly relieved. In the majority of cases, such as when there is a general differential elevation or depression of adjoining areas, or where there are horizontal displacements, the elastic rebounds on opposite sides of the fault are in opposite directions. The directions of the slow relative displacements on the two sides of the rupture and of the elastic rebounds, all of which are practically parallel with each other, may be vertical, horizontal, or inclined.

The sudden displacements, which occur at the time of an earthquake, are confined to a zone within a few kilometers of the fault-plane, beyond which only the disturbances due to elastic vibrations are experienced. The distribution of the distortion of the rock at the time of the California earthquake shows that the elastic rebound and consequently the elastic shear was greatly concentrated near the fault-plane and was much reduced in intensity at even short distances from it; this concentration of the shear brought about a strain sufficient to cause rupture after a comparatively small relative displacement of the surrounding regions; if the shear had been more uniformly distributed over a wider region, a larger relative displacement would have been necessary to cause a rupture and there would have been a greater slip at the fault-plane. Therefore, altho it is quite conceivable that regions at a distance apart of, let us say, several times 20 km., might be relatively displaced and set up a state of elastic strain in the broad intervening area, it would be necessary that the relative displacements of the distant regions should be at least several times 6 meters, in order that the strain should become great enough to cause a rupture; and if the strain were less concentrated than it was in California, the relative displacements would have to be greater still. It is only in the case of very large earthquakes that a slip as great as 6 meters occurs; and we may therefore infer that it is only in the case of large earthquakes that the sudden elastic rebound is appreciable as far as 8 or 10 km. from the fault-plane.

The rupture does not occur simultaneously at all parts of the fault-plane; but, on account of the elastic qualities of the rock, it begins in a very limited area and spreads at a rate not exceeding the velocity of compressional waves in the rock.

We should expect that the slow accumulation of strain would, in general, reach a maximum value and bring about a rupture in a single, comparatively narrow fault-zone; and this is probably what occurs for the majority of tectonic earthquakes, but it is quite conceivable that the strains should become so great along two or more separated zones, that the vibrations, set up by the rupture of one, might be sufficient to begin the rupture of the second; or indeed, that the relief of strain at one might cause additional strain at the other and thus start the rupture there, tho this seems improbable if they are as much as 20 or 30 km. apart. But it does not seem possible that large blocks of the earth's crust could be suddenly moved as a whole; if the material under the block slowly sank, the elasticity of the rock would allow the block to follow, still resting upon the substratum, and only a zone between the sinking area and the surrounding regions would be elastically strained and experience a sudden elastic rebound when the rupture occurred; and if the sinking area were large, the irregularity of the movement would probably bring about ruptures on different sides at widely different times. If a limited region should be elevated, exactly the opposite movements would take place. It must not be inferred, from what has been said, that small narrow blocks, from a few meters to a few kilometers in width, may not be raised or dropt as a whole, but they should be lookt upon as small blocks, forming a part of a single fault-zone and playing a very minor part in the general disturbance of the earthquake.

The Mino-Owari earthquake of 1891, the Formosan earthquake of 1906, and the California earthquake of 1906 are good cases of earthquakes practically with a single fault-zone; whereas, the great earthquake in the central part of Japan in 1896 resulted from fractures along two roughly parallel fault-planes 15 to 18 km. apart, and the intervening region was elevated 1 to 3 meters; one of the fractures was considerably longer than the other; and there is no evidence of any connecting fractures, which would separate the elevated region into a block; the faults apparently die out, as faults usually do, and the elevation diminishes towards their ends and finally disappears completely. The two fractures occurred at about the same time, but no determinations were made exact enough to show that they occurred simultaneously. The sharply defined areas in Iceland over which the earthquakes of 1896 were severally felt suggest that they were due to the settling of successive blocks, and this idea is strengthened by the fact that theregion is deprest and separated from the higher adjacent region by a fault. But the description given by Dr. Thoroddsen<sup>1</sup> does not indicate that the individual areas mentioned are bounded by faults, nor does he adduce any evidence that they sank at the time of the shocks, tho he does describe some large fissures which ran across several of them. Iceland is actively volcanic, and the descriptions of it suggest a very mobile condition not far below the surface. If this condition really exists, it would be much easier for cracks to form at approximately the same time and break up the crust into blocks there than in regions where the crust rests on a firmer foundation.

The elevations and depressions about Yakutat Bay, Alaska, which Messrs. Tarr and Martin have described as due to the earthquake of 1899, strongly suggest the movement of blocks;<sup>2</sup> but they did not find evidences of faultings on more than three sides of a block, and that in only one instance; tho it must be noted that they were unable to examine more than a very limited area and could not determine where the lines of fracture ended. It seems possible that the displacements they describe might be accounted for by an upward pressure, with or without a compression in a direction running north-northwest and south-southeast. Such a pressure and compression would bend the rocks into an arch, with the surface under tension, and the rupture would occur when this tension reached the limiting strength of the rock; the rupture would begin at the surface and

---

<sup>1</sup> Das Erdbeben in Island im Jahre, 1896. Petermann's Mitt. 1901, vol. XLVII, pp. 53-56.

<sup>2</sup> Recent Changes of Level in the Yakutat Bay Region, Alaska. Bull. Geol. Soc. Amer. 1906, vol. xvii, pp. 29-64.



extend downwards, and the ends of the broken rock would fly upwards, just as do the ends of a stick broken by bending, and an open fissure would be formed at the principal fracture; but along the side cracks the relative elastic rebounds might be in opposite directions and the parts might remain in contact. The principal fracture would be that in Disenchantment Bay, but no soundings have been made there to discover the existence of a fissure. Fissures and displacements of this character, due probably merely to compression, but on a very small scale, have been described.<sup>1</sup>

We know very little about the interior of the earth or of the origin of the forces which produce such great changes at the surface. Great thrust faults exist which indicate tangential compressions; and normal faults, which indicate expansion. Great uplifts have occurred unaccompanied by compressions, due, apparently, to vertical forces; and the California earthquake has emphasized the existence of horizontal drags below the crust. Future study may reveal forces applied in other ways; but it is not going too far to say that whenever ruptures occur, they result from elastic strain, and the sudden movements produced are merely elastic rebounds; and moreover, except in the case of earthquakes connected directly with volcanic action, the strains have not been set up suddenly, but are gradually developed by the slow displacements of adjacent areas. And severe earthquakes caused by shearing strains, vertical, horizontal, or oblique, where the elastic rebounds are in opposite directions on opposite sides of the fault, which remain in contact, will be more common than those due to the tensional strains of bending, where the elastic rebounds are in the same direction and a gaping fissure is opened.

#### THE PREDICTION OF EARTHQUAKES.

As strains always precede the rupture and as the strains are sufficiently great to be easily detected before the rupture occurs, in order to foresee tectonic earthquakes it is merely necessary to devise a method of determining the existence of the strains; and the rupture will in general occur in the neighborhood of the line where the strains are greatest, or along an older fault-line where the rock is weakest. To measure the growth of strains, we should build a line of piers, say a kilometer apart, at right angles to the direction which a geological examination of the region, or past experience, indicates the fault will take when the rupture occurs; a careful determination from time to time, of the directions of the lines joining successive piers, their differences of level, and the exact distance between them, would reveal any strains which might be developing along the region the line of piers crosses. In the case of vertical, horizontal, or oblique shears, if the surface becomes strained thru an angle of about  $1/2000$ , we should expect a strong shock. It would be necessary to start with the rock in an unstrained condition; this could readily be done now in the neighborhood of the San Andreas fault. The monuments set up close to the fault-line (vol. I, pp. 152-159) were not placed with this object in view, but with the object of measuring actual slips on the old fault-line. Measures of the class described would be extremely useful, not only for the purpose of prediction, but also to reveal the nature of the earth-movements taking place, and thus lead to a better understanding of the causes of earthquakes. Less definite, but still valuable, information could be obtained by the simpler process of determining, from time to time, the absolute directions of Farallon Light-house and Mount Diablo from Mount Tamalpais; by this means northerly or southerly movements of 1 foot of either of the first two stations relative to the third could be detected; and we should know if strains were being set up in the intermediate region; but we could not tell where the strain was a maximum nor to what extent it may have been relieved by small displacements on intervening fault-planes.

---

<sup>1</sup> F. Cramer, *Am. Jr. SeL*, 3d Series, 1890, vol. xxxix, pp. 220-225; and 1891, vol. xi\*, pp. 482-434. Mr. H. P. Gushing has shown me pictures of similar cracks with elevated lips in central New York.

It seems probable that a very long period will elapse before another important earthquake occurs along that part of the San Andreas rift which broke in 1906; for we have seen that the strains causing the slip were probably accumulating for 100 years. There have been no serious earthquakes reported along this part of the rift, except at its southern extremity, since the country has been occupied by white men, altho strong earthquakes have occurred in neighboring regions. It seems probable that more consistent results might be obtained regarding the periodicity of earthquakes if only the earthquakes occurring at exactly the same place were considered in the series. The Messina earthquake of December 28, 1908, seems to have resulted from a movement on the great fault passing thru the Straits of Messina. The last strong movement at the same place seems to have occurred in 1783; tho the Calabrian earthquake of 1905 may have been caused by a movement on another part of the same fault.

It is quite possible, however, for strong earthquakes to occur on neighboring faults after short intervals. The ruptures of the Haywards fault in 1868 and of the San Andreas fault in 1906 are a fair example, tho the interval is rather long. The Iceland earthquakes of 1896, already referred to, illustrate this much better. Five strong shocks occurred within fifteen days; but they were central, not in the same region, but in regions successively more and more to the west.

When a rupture occurs, the elastic rebound may carry the sides of the fault beyond their positions of no strain, and the friction may temporarily hold them there; or the friction may be so great that they do not entirely reach these positions. In either case further shocks may be expected before long; but they are apt to be slight, and are more likely to constitute *after-shocks* than independent earthquakes.

## SHEARING MOVEMENTS IN THE FAULT-ZONE.

### CHANGES IN THE LENGTH OF LINES.

In the general descriptions of the fault-trace it is shown that when the rupture occurred there was a zone of varying width between the shifting sides which did not partake of their simple movements, but was more or less distorted by the shearing forces to which it was subjected. The existence of this zone in alluvium or disintegrated rock may be explained even tho the fault were a sharply defined crack in the underlying solid rock. Let us suppose that the straight line  $AOC$  in the rock (fig. 17) has been broken at the fault and displaced into the two parts  $A'O'$  and  $D'C$ . If the alluvium were brittle and with little plasticity, it might be broken and displaced in the same way, but if it were plastic, as it would be if it were to some extent composed of clay, a part of the displacement would be accomplished by shearing distortion, and the offset at the fault-plane would be less than that of the underlying rock. Close to the rock the displacement of the alluvium would be very nearly the same as that of the rock (lines 1 in the figure); at greater distances, however, the distortion in the vertical plane would make itself felt; the offset would be less, and the displacement would be distributed more like the lines 2. The alluvium might be so thick or plastic that it would suffer no break at the surface along the fault-line, the whole displacement being distributed like line 3; this seems to be the condition which produces the *echelon phase* of the fault-trace in very wet alluvium, as described by Mr. Gilbert (vol. i, p. 66).

Special phenomena were exhibited in this zone of shearing distortion which might easily be misunderstood, but which can be explained fully on mechanical principles.

The zone was in some places only 2 to 6 feet wide, in others several hundred yards. Where it was broad the shift was divided in some cases among a number of cracks; in others it was distributed more or less evenly over the zone; in all cases, we have a zone of greater or less width subjected to shear; let us see what compressions and extensions take place in it. Let  $W$  and  $E$  (fig. 18) be the eastern and western boundaries of the sheared zone, whose width is  $I$  and let  $W$  move a distance  $s$ , short in comparison with  $I$ ; and let all other lines parallel with the boundaries also move a distance proportional to their distance from  $E$ .  $WN$  will be the direction of this motion; the line  $Ec$ , which makes an angle  $a$  with  $WN$ ,  $a$  being positive to the right of  $WN$ , is shortened by an amount  $cd$ ; and the simple geometry of the figure shows that the total shortening equals  $s \cos a$ ; and this is independent of the length  $Ec$ , provided only that the line  $Ec$  does not materially change its direction during the motion.; this is, in general,

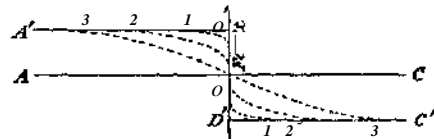

FIG. 17.

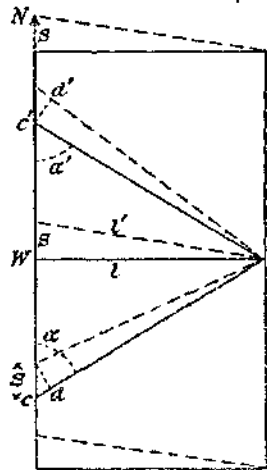

FIG. 18.

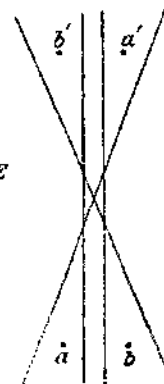

FIG. 19.

them would trend about north and south, as the fault runs about northwest. The subsequent movement seems in many places not to have obliterated this arrangement of the turf in strips, which is so characteristic that it indicates the position of a fault-trace without possibility of error, and shows the direction, tho not the amount, of the relative movement of the sides. Its appearance is shown in plates 16B, 39B, 43B, and it is sketched diagrammatically in figs. 18, 19, 20, vol. i.<sup>1</sup> An interesting example is shown in plate 65A and fig. 57, representing an auxiliary fault at the Morrell ranch; the direction of the diagonal cracks across the road shows that the northeastern side moved relatively to the northwest, a direction contrary to the movement observed elsewhere. This unexpected result is confirmed by the offsets of the fences bordering the road; a picture of the right-hand fence is shown in plate 64B, and a measure of the offset shows a relative movement of 3.75 feet. This anomaly is local and apparently very superficial, as it does not appear in the tunnel which is nearly under the point observed; the tunnel is offset normally a short distance to the east of the auxiliary fault.<sup>2</sup>

In places the subsequent motion has so broken up and so confused the earth clods that the regular diagonal cracks have been obscured; in places a slight compression or extension at right angles to the fault has entirely closed the cracks or made others more nearly parallel with the fault; but it is surprising how generally traces of the diagonal cracks can be seen when they are looked for. They are frequently described by the word *splintering*.

If the sheared zone runs along a slope, gravity acts as a tension on the higher part of the zone, increasing the tendency to form cracks and making them more nearly parallel with the fault-trace; in the lower part it produces a compression which tends to prevent the formation of cracks. This is the condition near San Andreas Lake (vol. i, p. 93).

Other cracks were made which apparently were not due to the shearing movements in alluvium which we have been considering; some, such as those in the Point Reyes region and those on Black Mountain (vol. 1, pp. 75, 107) seem due to a general shattering of the mass, and may be caused by vibratory motion (vol. n, p. 40); others (vol. 1, pp. 106-109) which are nearly parallel with the fault may in some cases be due to the topography, and in others to a small relative upthrust of one side of the crack.

In all parts of this report special efforts have been made to distinguish between cracks and dislocations due to the actual rupture along the fault, and those due to landslides, the settling of unconsolidated material, the slumping of river banks, the effects of vibrations, etc. This distinction is very important in order to interpret correctly the true movements of the underlying rock.

#### OFFSETS OF FENCES AND PIPES.

The distribution of shear over a broad zone is well illustrated by the distortion of fences; a number have been described in the preceding pages and illustrated by photographs and figures; we may refer especially to figs. 15, 31, 32, vol. 1. In some oases anomalies occur, which are probably not real, but which may be due to a misinterpretation of the observations; in fig. 29, for instance, the fence on both sides of the fault-line is dragged in the same direction, with shifts of 13 feet and 5 feet 9 inches on the two sides, respectively; at a distance from the fault-line there is only a very small relative displacement of the opposite sides; this is so opposed to the general character of the displacements that it probably does not represent the true movements. In fig. 38 a fence is represented as having been distorted to the south on the eastern side of the fault, for

<sup>1</sup> Professor Omori describes and explains this effect of the shear in his account of the earthquake of 1906, Bull. Imperial Earthquake Investigation Commission, vol. 1, No. 1, pp. 12-15.

<sup>2</sup> See Johnson's description, vol. i, top of page 277. Fig. 57 *m* badly drawn and shows the fence in the wrong direction.

a length of about 1,800 feet.

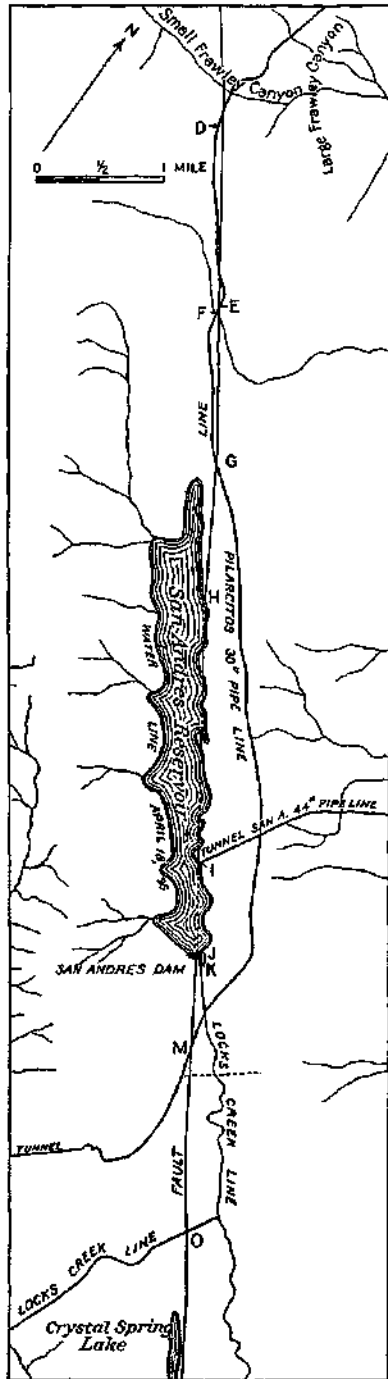

FIG. 22.

The pipe again crosses the fault near the head of San Andreas Lake, from right to left (*G*), and was pulled apart in two places a total of 6 feet 8 inches (plate 59A); this, with an offset of 6 inches, indicates that the angle between the pipe and the fault was but 3.5°.

There is no evidence that the zone of distributed shear had such a breadth in this neighborhood, and moreover the displacement of the fence is in the wrong direction to be explained by this means. Nor can we refer it to elastic rebound as described on pages 17-20 for the angle of shear would be more than 1/500 or about 7 minutes of arc, which is much greater than can be allowed. The displacements of the fence are measured from its inferred original position supposed to be a straight line, but we are not informed how the original position was determined. It would not be permissible to infer its direction from the continuation of the fence outside the eastern stone monument; and if the records of the original surveys gives the magnetic direction of the line, an imperfect knowledge of the magnetic declination and instrumental errors (if the line was run with a compass) would easily account for the deviation of 7 minutes between the present line and its supposed original direction. It seems probable therefore that the true distortion was confined to a comparatively short length of the fence. There seems no clear explanation of the bow-shaped distortion of the fence in fig. 34, unless the fence originally had this shape.

The Pilarcitos 30-inch wrought-iron pipe of the Spring Valley Water Company runs near the fault for a distance of two miles northwest of San Andreas Lake and crosses it four times (vol. i, p. 95). The map (fig. 22), taken from the report of Mr. H. Schiessler, chief engineer of the company, shows the location of this and of some other pipes of the company. Beginning at the northwest the pipe crosses from left to right at Small Frawley Canyon, and the angle between the pipe and the fault-line is 20°; the shortening of the pipe is 7 feet 3 inches, and the offset is 15 inches, corresponding to a total shift of 8 feet, as determined by the formula on page 34.

We have no information about the break at the next crossing, from right to left, and about a mile distant; the pipe runs nearly parallel with, and close to, the fault between these crossings and suffered many ruptures; in one place it completely collapsed.

At the next crossing (*F*), very near the last, the pipe crossed from left to right at an angle of 15°; it was crushed in three places, the total shortening being 9 feet 8 inches (plate 59B and p. 96, vol. i); this corresponds to a shift of 10 feet.

A half mile southeast of San Andreas Lake the pipe crosses the fault for the last time (*M*), from left to right at an angle of  $65^\circ$  (vol. i, p. 100); it was crushed and shortened 22 inches; 100 feet to the north it was crushed again, the compression there being 1 foot. The total shortening, 2 feet 10 inches, corresponds to a shift 6.75 feet; as the shift at the fault-line was only 20 inches, a part of the shear must have been distributed.

Near the northwestern end of Crystal Springs Lake the 44-inch Locks Creek pipe crosses the fault-zone from left to right at an angle of  $65^\circ$  (fig. 22, *O*, and vol. i, p. 101, fig. 39); it was crushed at four points, and pulled apart 3 inches at one point; the total shortening was 59.25 inches; this corresponds to a total shift of 11 feet 8 inches, the greater part of which was distributed.

The shifts indicated by the changes in length of the pipes must be looked upon in many cases as smaller than the true shift, for many other ruptures occurred, which are noted in the report of the chief engineer of the water company, but of which no details have been given.

#### EFFECTS ON OTHER STRUCTURES.

The two best examples of combined shortening and stretching are furnished by the gate-well on the shore of San Andreas Lake and by the flume and the waste-weir at the southeastern end of the lake; they show the existence, at the same place, of shortening and stretching in different directions, altho there is no indication of a compression or extension at right angles to the fault. The gate-well was stretched in a direction N.  $79^\circ$  W. and shortened at right angles to the stretching (vol. i, pp. 98, 99, fig. 35). The direction of the fault-trace is about N.  $35^\circ$  W., so that the directions of greatest stretching and shortening make angles of practically  $45^\circ$  with the directions of the fault. From the scale of the figure the stretching is found to be 3 feet 4 inches, which corresponds to a shift of 4 feet 8 inches. This is less than the shift in this part of the fault and confirms the evidence, furnished by cracks in the ground, that the shear was distributed over a greater width than 18 feet, the projection of the diameter of the well (25 feet) in the direction of greatest stretching upon a line at right angles to the fault-trace.

The Locks Creek flume, a 44-inch wrought-iron pipe, crosses a part of the sheared zone from right to left at an angle of  $15^\circ$  (vol. I, pp. 99, 100; fig. 36); it was pulled apart 4 feet, corresponding to a shift of 4 feet 2 inches. If the pipe had entirely crossed the sheared zone, it would have indicated a greater shift, which could not have been less than 7 feet at this point, according to the displacement of a fence shown in the same figure; the flume passes thru a concrete culvert and continues to San Andreas Lake; as this part of the pipe and culvert were parallel with the direction of the shear, they were uninjured. 275 feet from the break in the flume a strongly built brick waste-weir tunnel crosses the sheared zone from left to right at an angle of about  $57^\circ$ ; its great strength prevented it from being entirely destroyed, but it was crushed at the fault-line and shortened, tho the amount was not measured.

The examples given show very clearly that the shortening and stretching of lines in the fault-zone was not due to any general expansion or compression causing changes of area, but to shear; and the character and amount of change in length of any particular line depended on the direction in which it crossed the fault-zone and the angle it made with the direction of shift; so that, in some instances, of two lines crossing the fault-zone at the same point but from opposite sides, one was lengthened and the other shortened. It is quite possible that there were, in places near the surface, slight expansions or compression at right angles to the fault-line. As pointed out (vol. i, p. 73) the fault-plane can not be considered a mathematical plane, and the movement must have caused a slight separation of the sides in places near the surface, which may be indicated by the trench-form of the fault-trace. It is difficult to understand how the two sides of the

fault could be made to approach each other in the region of solid rock at a distance below the surface, but it is quite possible that the more unconsolidated material near the surface might be shaken together by the earthquake. ^An illustration of this may perhaps be found in the compression of the fence and the sagging of the telephone wire which cross the causeway dam between the Crystal Spring Lakes, approximately at right angles to the fault (vol. I, p. 102).

The shortening of the railway track by 7 inches between Wright and Alma (vol. I, p. 110), a distance of 5 miles, can hardly be referred to distributed shear; the track has many curves and runs in places by the sides of steep mountain slopes; and a slight shaking down of the roadbed in places might straighten the track sufficiently to shorten it by this small amount.

## VIBRATORY MOVEMENTS AND THEIR EFFECTS.

---

### CHARACTER OF THE MOVEMENTS.

When the rupture occurred on the fault-plane, it is probable that the movement did not begin at the same moment at all parts of the plane; it probably started in some limited region, and the stress, being relieved by the break there, was concentrated upon nearby points which gave way, and thus the rupture spread from point to point until it extended over the whole fault-plane; and it is also probable that the whole movement at any point did not take place at once, but that it proceeded by very irregular steps.

We can determine roughly the time which would have been required for the rock to come back to its natural position of equilibrium if it had vibrated freely without friction. The period of vibration of the rock, distorted by simple shear, as explained on page 50, is given by the expression  $T_0 = 4H\sqrt{p/n}$ ; where  $H$ , the distance from the fault-plane to which the distortion extends, may be taken as 6 km. (3.7 miles),  $p$  is the density of the rock, say, 2.6; and  $n$  is the coefficient of rigidity, say  $2 \times 10^{10}$  dynes per square centimeter (2,900,000 pounds per square inch).<sup>1</sup> With these values of the constants we find the total period to be about 8.7 seconds, or the time for the rock to move from its original displacement to its position of equilibrium one-fourth of this, or 2.2 seconds. This is found from the equation of the free vibration of the rock, in which case the straight line at right angles to the fault is distorted so as to be concave toward its position of equilibrium; but the observations in fig. 5 (page 16) show that the rock was distorted with the convex side toward the position of equilibrium. If therefore the break had been sharp, with no friction at the fault-plane, we should have had vibrations containing higher harmonics, so that the rock at the fault-plane would have made rapid but short vibrations back and forth during the 2.2 seconds necessary for it to reach the equilibrium position. This, however, was not what actually occurred; small slips took place at different parts of the fault-plane, and as the results of these successive slips and the great friction, some 30 to 60 seconds were required before the rock came to rest; and even then certain parts of the rock were apparently still held in a strained condition by strong friction, and from time to time gave way, producing the aftershocks which are listed in another part of the report.

The more or less sudden starting and stopping of the movement and the friction gave rise to the vibrations which were propagated to a distance. The sudden starting of the motion would produce vibrations just as would its sudden stopping; and vibrations are set up by the friction of the moving rock, exactly as the vibrations of a violin string are caused by the friction of the bow; the string vibrates altho the bow is drawn steadily across it; or as vibrations are set up in a finger-bowl when a wet finger is drawn along the edge; in this case we can see the vibrations transmitted to the water in the bowl.

Vibrations once started are propagated as elastic waves in the rock and consist in general of compressional waves like simple waves of sound, in which the vibratory movement of any particle is in the direction of propagation; and of transverse waves like those of light, in which the movement of the vibrating particle is at right angles to the direction of propagation. As a compressional wave advances, the mass of rock thru which it passes is subjected to successive compressions and extensions.

---

<sup>1</sup> See p. 21.



## CRACKS FORMED IN THE GROUND AND THE BREAKING OF PIPES.

We can readily determine the amount of compression and extension that takes place; the movement of an earth particle is given by the expression

$$y = A \cos 2\pi \left( \frac{t}{P} - \frac{x}{\lambda} \right)$$

where  $A$  is the amplitude,  $P$  the period,  $X$  the wave-length,  $t$  the time, and  $x$  the distance, measured in the direction of propagation; the compression and extension is given by

$$\frac{dy}{dx} = -\frac{2\pi A}{X} \sin 2\pi \left( \frac{t}{P} - \frac{x}{X} \right)$$

and its maximum value is  $2\pi A/X$ . For a wave whose period is a half second and whose velocity is 4 miles a second,  $X$  would be 2 miles or say 10,500 feet, and if  $A$  were 0.2 of a foot, the wave would cause successive compressions and expansions of short lengths of rock amounting to 1: 8350 of the length. If  $c$  is the compression or expansion per unit length and  $M$  the modulus of elasticity, which for granite with a free upper surface would be about 7.66 million pounds per square inch, the force exerted is  $cM$ , or, in the case of the above wave,  $\frac{7.66 \times 10^6}{8350}$ , or 920 pounds per square inch. This is much less than the force necessary to break granite by crushing (6 to 10 tons per square inch), but the strength of granite under tension must be less than under compression, altho its value is not known.

Cast-iron, which resembles granite in its general structure, requires four or five times as large a force to break it by crushing as by stretching; it therefore seems possible that the numerous cracks observed in the region west of Point Reyes station may be due to the vibrations. In the case of vibrations passing thru alluvium or decomposed rock, the wave-length will be shorter, the amplitude greater, and the breaking strength much less in comparison with the modulus of elasticity; so that we should expect in places, where the condition of the ground is favorable, even at a distance from the earthquake's origin, that cracks would open and close at right angles to the direction of propagation; it is to this cause we must refer the opening of cracks and the projection of water, mud, and sand into the air, which has frequently been described in connection with strong earthquakes. This phenomenon was seen in the neighborhood of Salinas (vol. I, p. 245). In very unconsolidated deposits cracks may be left open by the compression of the intervening material and water arising in the cracks may form craterlets (vol. I, pp. 229, 231, 338); but cracks formed by slumping of the ground, altho started by the vibrations, are practically due to gravity.

Pipes in the ground were subjected to similar compressions and extensions, the measure of the force being  $Ec$ , where  $E$  is Young's modulus for the material of the pipe. For cast-iron  $E$  is about 5,000 tons to the square inch and with an extension of 1: 8,350, the force tending to rupture it would be about 0.6 ton to the square inch. For wrought-iron  $E$  is about 13,000 tons to the square inch and the force developed by the above expansion would be 1.6 tons; it requires from 20 to 28 tons to break wrought-iron by tension, and 16 to 20 tons by crushing; but at the joints the pipes are weaker. On the whole, not many pipes in the ground were broken by the vibrations, tho the stronger vibrations in alluvial soil must have broken a number. A very good example is the pipe near Salinas (vol. i, p. 245), which was broken in many places; in some places the ends were separated as much as 3 feet, in others they overlapt as much as 4 feet; and they showed that they had been hammered together and had not simply been pulled apart. A pipe seen near Alvarado had had the same experience (vol. i, p. 305).

In the calculations above we have supposed the pipe so firmly embedded in the surrounding earth that it moves with the earth; under this supposition the strength of the pipe to resist rupture due to vibrations would not be changed by altering the thickness of the pipe; but if the pipe slips in the ground, as it might if it were very straight for distances of half a wave-length or more, it might be strengthened by making it thicker; but it is hardly practicable to lay pipes straight for such distances, and therefore we should not seek to strengthen pipes in the ground by making them thicker; but they would be strengthened by selecting a material with a large ratio of its breaking strength to its Young's modulus. Wrought-iron pipes would yield by crushing rather than by tension, whereas cast-iron would yield first by tension; but it would require a stronger vibration to pull apart a cast-iron pipe than to crush one of wrought-iron. In general, however, the joints are the weakest spots and the ruptures occur there.

The Spring Valley Water Company sends water to San Francisco thru three pipes (map No. 21, and fig. 22). The San Andreas pipe draws directly from the lake of the same name; altho it starts at the fault-line it was ruptured at one place only, where it crosses a marsh at Baden Station on a trestle. The pipe here was weakened by an extension joint, the two ends being held together by wires passing over lugs on the pipes; these lugs were pulled out. The lack of injury to the pipe at other places shows that, where buried in the ground, it was quite strong enough to stand the compressions and extensions due to the vibrations, and makes it probable that the many injuries received by the two other pipes, not along the fault-line, and of which we have no details, were due to some special causes of weakness at the points where they occurred. When the pipe was buried, it was prevented from bending and was then strong enough to remain-intact, but where it was carried on a high trestle, or on a trestle over a soft marsh, bending was possible and its power of resistance was similar to that of a column under compression; as is well known, a column yields, not by crushing, but by bending.

The Pilarcitos 30-inch wrought-iron pipe is carried across Large Frawley Canyon on a high trestle about half a mile east of the fault (plate 100A); the pipe is buried on each side of the canyon, the intervening length being 100 feet; this portion was broken into two pieces of practically equal lengths which, together with the greater part of the trestle, were thrown into the canyon and left side by side, 50 or 60 feet from their original position. The ruptures occurred at riveted joints, the two pieces being otherwise intact. It is clear that the portion of the pipe on the trestle must have acted like a column with fixt ends. The formula which most accurately represents the strength under these conditions is known as Rankine's formula,<sup>1</sup> and is

$$p = \frac{f}{cL^2/k^2},$$

where  $p$  is the pressure in tons per square inch necessary to cause the collapse, and  $f$  and  $c$  are constants, the first dependent upon the material of the column only, the second both upon the material and upon the character of the ends;  $L$  is the length of the column and  $k$  is the radius of gyration of the cross-section. For wrought-iron  $f$  is 16 tons per square inch;  $c$  is 1: 36,000 for a pipe with fixt ends;  $k^2 = \frac{d^2}{8}$ , where  $d$  is the average of the inside and outside diameters; so that the formula becomes

$$p = \frac{16}{1 + \frac{1}{4500} \left(\frac{L}{d}\right)^2}.$$

The length of the pipe over Large Frawley Canyon is 100 feet and the diameter 2.5 feet, therefore  $\left(\frac{L}{d}\right)$  is 1,600, and  $p$  the pressure necessary to break it, become 11.5 tons per

<sup>1</sup> Swing's Strength of Materials, p. 178.

square inch. The compressive force due to the vibrations calculated in the example we have used (with Young's modulus for wrought-iron equaling 28,000,000 pounds per square inch) is only about one-eighth as great, but at this short distance from the fault-plane it is possible that the vibrations may have been greater, and without doubt, the pipe itself, on account of the joints, would give way under a much smaller pressure than is required by the above formula; we must believe that the pipe yielded like a column under compression, and the sudden removal of the resistance when the rupture came allowed the elastic forces to throw the pieces 50 or 60 feet to the side.

The Crystal Spring 44-inch pipe suffered in the same way where it crossed the San Bruno marsh near South San Francisco and the Guadeloupe and Visitacion marshes a little further north. The trestle which carried the pipe over these marshes was built on deeply driven piles. The pipe was broken in many places and the pieces flung 4 or 5 feet to right and left; the trestle was also demolished, but the piling and its capping were in general uninjured. In some instances, however, the pipe seems to have been raised into the air and to have come down with sufficient force to destroy the trestle and crush the heavy timbers bolted to the tops of the piles. Altho the vibrations in these marshes must have been very violent, it was found after the earthquake that no permanent displacement had taken place; the piling had not lost its alignment nor its grade.

It does not seem probable that the lateral vibration was strong enough to break the pipe and throw the pieces 4 or 5 feet; the pipe must have been quite flexible enough to yield to such vibrations without breaking; nor is it probable that the vertical vibration was strong enough to throw the pipe upwards; it is most probable that we have here again to do with compressional vibrations, acting upon parts of the pipe as upon columns with round ends, for the ends of the short lengths of the pipe, over which the compression was strongest, were practically free to turn the small amount required. We suppose the vibrations to be communicated to the pipe thru the trestle and to be transmitted along the pipe as forced vibrations, with the same period and velocity, and therefore with the same wave-length, as in the underlying marsh; but there would undoubtedly be propagated in the pipe vibrations having a velocity appropriate to the material of the pipe, and these would in places combine with the forced vibrations, to produce unusually large forces of compression and tension.

Rankine's formula for the yielding of columns with round ends becomes

$$p = \frac{16}{1 + \frac{4}{4500} \left(\frac{L}{d}\right)^2}$$

With a 44-inch pipe  $L/d$  would be 40 for a length of about 150 feet, and  $p$ , the force necessary for collapse, then becomes 6.6 tons per square inch; which is about 4 times the pressure calculated in the example we have taken above; but in the marshes the wave-length would be greatly reduced, and there seems no difficulty in believing that the compressions were in places sufficient to break the pipe regarded as a column with rounded ends (especially at the joints), and then to fling the pieces to the side. Where the pipe had a slight bend in the vertical plane, the compression would throw it up rather than to the side, and in this way its subsequent blow upon the support is made clear. One piece of pipe, about 800 feet long, was found lying on the ground by the broken trestle uninjured except at its ends; it must have rolled off the trestle after the supporting sides had been battered off.

The San Bruno marsh is about 2 miles from the fault-line and the other two marshes about twice as far. The increase in intensity of vibration due to the character of the foundation far more than made up for the diminished intensity due to distance, as shown by the distribution of isoseismals on map No. 23.

## CRACKS IN WALLS AND CHIMNEYS.

In Mallet's great report on the Neapolitan earthquake of 1857 he assumed that the waves were propagated thru buildings just as thru the earth below, and concluded that the cracks made in the walls were at right angles to the direction of propagation of the waves. From this he deduced the direction of propagation and the position of the focus. But the length of buildings is only a very small fraction of the length of a seismic wave; and in them the proper conditions for the rectilinear propagation of waves do not exist; so that Mallet's assumption and his conclusions can no longer be accepted. Lines drawn at right angles to the cracks on the floor are probably at right angles to the direction of propagation of longitudinal waves, for these cracks are practically formed in the ground, like those described above; but cracks in walls can not be looked upon as at right angles to the direction of the movement, even when no windows are present to cause special weakness in some directions. We shall form a better conception of the mechanical conditions if we look upon the wave as divided into two components, one producing a horizontal vibration of the house and the other a vertical vibration. If, as is usually the case, the house is longer than it is high, the inertia opposing the motion will produce a horizontal shear and it may be shown, by the method used on page 34, that cracks have a tendency to form at an angle of  $45^\circ$  with the horizontal in walls running in the direction of the vibration; as the motion is first in one direction and then in the other, two sets of cracks would be formed at right angles to each other, and each  $45^\circ$  with the horizontal. The vertical component produces vertical compression and expansions which may slightly modify the direction of the cracks. This is exactly what was observed; many walls exhibited the double system of diagonal cracks. An excellent illustration of these cracks in the St. James Hotel at San Jose is given by Professor Omori.<sup>1</sup>

Chimneys, and walls running at right angles to the direction of the vibrations, were affected in a different way; they are high in comparison with their breadth and consequently were set into vibrations, like long rods. As they swayed back and forth they bent and were compressed on the concave and stretched on the convex sides. If this stretching exceeded the elastic limit of the material, a horizontal crack was made. It was in this way that chimneys were overthrown and the tops of walls and gables were thrown out. In practically all cases of brick walls and chimneys the break occurred at a joint and the bricks which were thrown down were usually unbroken, but entirely detached from each other, showing that the mortar was very weak. Chimneys of uniform thickness would naturally break at their lowest free point, which, in the case of the chimneys of houses, is where they pass thru the roof; and walls would break where they are not well braced, which was usually near their tops or in the gables or at the corners. The high chimneys of factories are thicker near the ground and gradually diminish in diameter and thickness from the ground up. They did not break at the ground, but at some point about a third of the way up where the bending moment was greatest in comparison with their strength. It by no means follows that a broken chimney will fall; in regions where the shock was not so very strong, many short chimneys were broken, and the detached part rocked on the lower part without overturning; the very small power of stretching possessed by brick and mortar caused chimneys to break before they were sufficiently inclined to lose their balance and fall.

## ROTATORY MOVEMENTS AND THE ROTATION OF OBJECTS ON THEIR SUPPORTS.

It has been a matter of frequent observation that during the shocks of large earthquakes a twisting motion is felt, and after the shock, chimneys which were not thrown down, monuments in cemeteries, ornaments, etc., are found to have been rotated on their

---

<sup>1</sup>Bull. Imperial Earthquake Investigation Commission, vol. i, No. 1, plate iv.

supports. This has given rise to the belief that there is a rotary motion of the various parts of the ground like that of wheels about their axes. It should be pointed out that this kind of motion can not exist, for it could not be propagated as an elastic disturbance, but would break up into waves of compression and distortion, which would be propagated at different speeds and would soon be separated from each other. Moreover such a motion would produce rents in the ground, which have not been found; nor has any such motion of the ground itself ever actually been observed. Waves of elastic distortion do, however, produce very small rotations, whose maximum amount, we shall see (page 146), is given by the expression  $\frac{2\pi A}{\lambda}$ , where  $A$  is the amplitude and  $\lambda$  the wave-length; with a wave as short as 10,000 feet (3 km.) and an amplitude as large as 0.2 of a foot (6 cm.), the maximum rotation would only be about 0.25 of a minute of arc, a quantity far too small to be noticeable; even if the rotation were 100 times as great as this, it would probably not be noticed.

But there is another kind of rotation, which undoubtedly does occur, and which would, if strong enough, give rise to the sensation of twisting and would cause objects to rotate on their supports. If a swinging pendulum, as it passes its lowest point, should receive a blow at right angles to the direction of its motion, it would simply change its direction and continue to swing back and forth in a different plane; but if the blow should be received at any other part of its motion, it would swing in an ellipse; if the blow were of the right intensity and were received at the end of the swing, the pendulum would swing in a circle.

Two vibrations making an angle with each other would produce just such an elliptical or circular motion, unless they were so adjusted that they would combine to make a simple linear vibration in a direction between the two; but this would rarely occur. If the two groups of combining vibrations had different periods, the resulting movement would be very complex; and we might have rotations first in one direction and then in the other. The kind of rotatory motion thus set up is not like that of a wheel about its axis, but is like that of a book which is carried around in a circle keeping the edge always parallel to its original position. We must look upon the rotatory motion of the earth reported during earthquakes as such that every point describes an ellipse, each point with a different center, but all with parallel axes; and the lines connecting near-by points remain parallel to their original directions, and do not, as in the case of a wheel, also rotate. For the sake of clearness let us speak of this kind of motion as *parallel rotation*, to distinguish it from rotations where the various points rotate around the same center.

We have conclusive evidence that the motion of the earth during the Californian earthquake was not merely a to-and-fro motion in one direction, but that the direction of the motion changed markedly. This is shown by the sensations of observers and by the fact that objects in the same place were thrown in various directions; statements that the earthquake was a "twister" were not uncommon, and some observers reported that the motion was first in one direction and then at right angles to it; and lastly the seismographs themselves indicate a combination of simple vibratory motions; this is well shown in the seismogram made by the simple pendulum at Yountville, and in all made by Ewing duplex pendulums. (See Seismograms, sheet No. 3.)

We can picture to ourselves many ways in which movements in different directions could be produced at the same time. Suppose, for instance, that there were two shocks originating at the same place with some seconds interval between them; each in general would give rise to compressional and distortional waves; the first kind travels faster and hence outraces the second. The compressional waves of the second shock would overtake the distortional waves of the first shock in a circular zone surrounding the origin, and as their motions are at right angles to each other, we should find parallel rotations in this

zone. Again, suppose two shocks originated at different centers, their waves, in general, would cross each other at an angle, and we might have circular or elliptical motion as a result of the combination of the two sets of compressional waves, of the two sets of distortional waves, or of each set of compressional with the other set of distortional waves. Modifications of the waves on passing from one kind of rock to another would occur and give rise to still other combinations which would cause parallel rotations.

With the hope of throwing light on the progress of the rupture along the fault-plane by determining the distribution of rotatory effects in the surrounding regions a special list of questions was sent out and many answers were received. They may be summarized as follows: at a distance, where the shock was but slightly felt, rotations were rarely noticed; but where the shock was strong, even tho many miles from the fault, they were almost universal; a number of observers stated that the disturbance was first a simple vibration, and that the rotatory motion only appeared later; no one put the rotatory motion in the early part of the shock. Some, who did not notice rotations, stated that the direction of the motion changed during the disturbance. At a distance from the fault, where the movement was slow and gentle, the rotatory effect would not be very noticeable, but that it still existed is shown by the seismogram made at Carson City, where the intensity of the shock was greatly reduced. This general distribution of parallel rotations does not show how the rupture took place on the fault, but merely confirms the idea that the disturbance at any point was due to vibrations originating in many parts of the fault-plane; and the combinations of these vibrations would cause the variations in intensity and the rotations observed. The writhing motion of the steel smokestack at Mare Island (vol. i, p. 212) must have been the result of a double vibratory motion of the ground combined into a parallel rotation; the elastic bending of the stack would cause a much greater vibration of the top than of the bottom; this explains the whole motion without the assumption of a tilting of the ground.

In the first volume numerous examples are given of statues, monuments in cemeteries, chimneys, etc., which were rotated on their supports by the earthquake; many were turned thru an angle of  $90^\circ$  and some as much as  $180^\circ$  (vol. i, p. 359), tho in the majority of cases the rotation was less than  $20^\circ$ . In the cemetery near San Rafael all except one of the rotated monuments were turned with the hands of a watch thru angles of  $16^\circ$  or less. Similarly, at Lakeport all the rotated chimneys were turned in the same direction (vol. I, p. 188). This phenomenon has long been observed and occurs at the times of all violent earthquakes; it naturally suggests a rotation of the support; but, as has been seen, a more careful examination of this idea shows that it is entirely untenable; indeed, Charles Darwin long ago pointed out that if objects were turned on their supports by true rotations, the axis of each rotated object must be an axis of the rotation, which is a practical impossibility. The effort, therefore, was made to explain the rotation merely as the result of a to-and-fro vibration. What is necessary is to produce a moment around the vertical axis thru the center of gravity.

Three suggestions have been made. First: Mallet<sup>1</sup> suggested that the object may not bear uniformly on its support, but may only press on it in a few points, and as the pressure will in general be different at these points a moment around the center of gravity due to the frictional forces would be produced during a vibratory movement, resulting in a rotation. Altho it may be possible for small rotations to be brought about in this way, they are probably very small and unimportant; for it can easily be shown that if the frictional forces at the points of contact follow the ordinary laws of solid friction, namely, that the tangential forces are proportional to the normal pressures, then no moment around a vertical axis thru the center of gravity will be set up by the vibrations, and it is only in so far as the ordinary laws of friction are departed from that moments can be

---

<sup>1</sup> Dynamics of Earthquakes. Trans. Roy. Irish Acad. 1846, vol. xxx, pp. 51-105.

produced. For the normal pressures must be such as to produce no moment around any straight line in the plane of the points of contact and immediately under the center of gravity; otherwise, the object, when undisturbed, could not remain stationary.

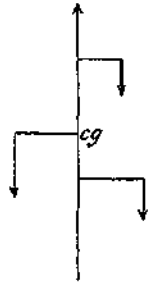

FIG. 23.

If now we take the straight line parallel with the direction of vibration, the moments of each frictional force about the vertical, thru the center of gravity, will be proportional to the moment of the corresponding normal force about the straight line, and therefore their sum will be zero. Houses, however, are not rigid bodies resting on rigid foundations, like a statue on its base; and the ground itself, on account of slight variations in texture or firmness, would not behave like a rigid body during the earthquake, but would have somewhat different movements at different places under the house; in this way it is quite possible for a house to be slightly rotated by the frictional forces between it and its foundation. Examples of such rotations are given in vol. I, pp. 170, 176.

Second: Professor Thomas Gray \* has shown that if the vibrations are at right angles to the edge of the rectangular base of a column, or along the line joining opposite corners, no rotating moment is developed; but if the shock lies between these directions, as, for example, in the direction, *of*, in fig. 24, then the column tends to rock on the corner, and to rotate around it; for the force is applied at the corner and acts in a direction parallel with the vibration and does not pass through the center of gravity. This is in entire accord with the laws of mechanics, and undoubtedly some small rotations are caused in this way; but it is to be noticed that the tendency is only to rotate until the edge is at right angles to the direction of vibration; if this direction is nearly at right angles to the edge, the rotation will be small; if the direction is nearly along the diagonal, the moment produced will be small; if the direction of vibration gradually changes, keeping pace with the turning of the column, a larger rotation might accumulate. In the case of columns with circular bases, the method would not apply at all; and it may be well doubted if any large rotations are produced in this way.

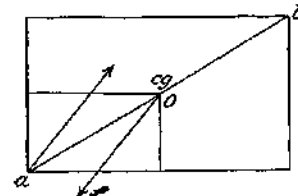

FIG. 24.

Third: The combination of vibrations at right angles offers a simpler explanation for any amount of rotation and for any form of base. If an object, as a result of the vibration, is rocking on its edge and is then subjected to a second vibration at right angles to the first, a strong moment will be set up and the object will rotate; if these vibrations are so timed as to produce parallel rotation of the support, the body will continue to rotate as long as the vibrations are sufficiently strong. One can easily realize this experimentally by means of a chair. Raise the front legs slightly from the floor by pressing against the back; then press against the side of the chair, and it will swing around about  $90^\circ$  on one leg; or, place a box or bottle on a book, and then rotate the book, keeping it parallel with itself; if the movement be strong enough and the friction sufficient to prevent slipping, the object will rock and rotate. The principle of cross vibrations seems to be the true explanation of the rotation in most cases and in all cases where the rotation is large. Cross vibrations will not be produced by a single shock from a single center; but a protracted shock, or successive shocks from the same center, or shocks from different centers, will produce them; that is, they will practically occur at the time of all large and important earthquakes, for then the vibrations usually originate at many points and at slightly different times.

\* Milne, The Earthquake in Japan of Feb. 22, 1880. Trans. Seism. Soc. Japan, vol. i, part II, pp. 33-35; and *Seismology*, p. 170.

The explanation of rotations by means of cross vibrations seems first to have been given by F. Hoffmann\* and later repeated independently by Mallet<sup>2</sup> and others, but it does not seem to have received the consideration it deserves. I think it is clear from this chapter that cross vibrations are not only capable of explaining rotations wherever the disturbance is sufficiently strong, but that no other theory, so far proposed, can explain satisfactorily the very large rotations which statues and monuments experience.

SURFACE WAVES IN THE MEGASEISMIC DISTRICT.

In addition to the ordinary vibrations which we have been studying, many persons reported waves in the ground which had the appearance of ordinary waves on the surface of water (vol. I, pp. 380, 381). They were not a peculiarity of the California earthquake, for similar phenomena have been recorded in connection with almost all great earthquakes and have given rise to much discussion as to their cause. It is probable that they result from the modifications of condensational vibrations by the surface, as appears from the following considerations. The resistance of a substance to compression and distortion depends upon the values of two coefficients:  $k$ , the coefficient of compression under equal pressure in all directions, and  $n$ , the coefficient of rigidity or shear. If we compress a small cube of any substance between two plates, the modulus of compression, that is, the ratio of the applied forces per unit area to the linear contraction, is called Young's

modulus, and its value in terms of the coefficients mentioned above is  $\frac{9nk}{3k-2n}$ . This

represents the resistance which the substance offers to compression. When the pressure is exerted, the cube is not only compressed in the direction of the pressure, but it expands at right angles to this direction, and the ratio of this expansion to the normal compression\* is  $\frac{4n}{3k-2n}$ . The value of this ratio varies with different substances, but in general it is not far from 1:4. When the vibrations pass thru the interior of the earth, the rocks are subjected to compressions and expansions, but the surrounding rock allows only longitudinal contraction or expansion and the modulus of elasticity is then given by  $\frac{3k+4n}{8k+4n}$ , which is greater than Young's modulus. At the surface expansion can take

place upwards but not laterally, and it can be shown that here the modulus of elasticity is given by the expression  $\frac{3k+4n}{8k+4n}$ , and the ratio of the vertical expansion to the longitudinal contraction is  $\frac{3k-2n}{8k+4n}$ .

The values of  $k$  and  $n$  have been determined for a number of specimens of rock by Messrs. H. Nagaoka,<sup>3</sup> S. Kusakabe,<sup>4</sup> and Adams and Coker.<sup>5</sup> The average values which the last investigators found for granites are  $k = 4.3 \times 10^6$  pounds per square inch, and  $n = 3 \times 10^6$  pounds per square inch; and the vertical expansion would be nearly 0.3 of the longitudinal compression. As we pass down from the surface the increasing weight of overlying rock would greatly diminish the vertical expansion, and at a depth comparatively small would prevent it altogether. The actual vertical movement at the surface would be the addition of all the vertical expansions from the surface down. A longitudinal contraction of 1: 8,350, as found in the example already used, would cause a vertical

<sup>1</sup> Nachgeschene Werke, 1838, vol. n, p. 310.  
<sup>2</sup> The great Neapolitan earthquake, vol. 1, pp. 375-381.  
<sup>3</sup> Elastic Constants of Rocks and the Velocity of the Seismic Waves. Publications of the Earthquake Investigation Commission in Foreign Languages, No. 4, 1900; and Phil. Mag. July, 1900, vol. t.  
<sup>4</sup> On the Modulus of Rigidity of Rocks. Publications of the Earthquake Investigation Commission in Foreign Languages, No. 14, 1903; No. 17, 1904; and No. 22B, 1906.  
<sup>5</sup> An investigation into the Elastic Constants of Rocks, etc. Carnegie Institution of Washington, Publication No. 46, 1906.



expansion of about 1:30,000; if we assume that the weight of the overlying rock would make the vertical expansion practically disappear at the depth of a mile; and if we assume further that the average expansion above this point is one-third of its value at the surface, we should find a vertical amplitude at the surface of 0.66 inch, or a range from crest of trough of the waves of 1.33 inches.

Referring again to the expression for the ratio of the vertical expansion to the horizontal compression we see that its value will become greater as  $n$  becomes smaller, with unity for its greatest possible value. When the waves pass from rock into alluvium or distinct-grained rock, the amplitude may become distinctly larger, and since the value of  $n$  would be much less than for granite, we should expect far larger surface waves. The movement at the surface will be upwards, forwards, downwards, and backwards in the vertical plane, just like the movement in ordinary water waves. Waves of this kind must necessarily occur wherever we have longitudinal vibrations, at a great distance from the focus as well as near it, but it is only where the amplitude of the vibration is very large that the surface waves are visible to the eye; and it is, therefore, only near the focus, and generally only on alluvium that they are observed, and only in the case of very violent earthquakes. These waves must not be confused with the Rayleigh waves, in which the horizontal component of the vibration dies out at a depth of about one-eighth wavelength, and the vertical component continues to indefinite depths; whereas the waves we have just described have exactly the opposite characteristic; they are simply the surface modification of the ordinary longitudinal waves, which exist below the surface.

It is also possible that surface waves could be formed by transverse vibrations, in which the direction of motion is vertical.

Major Dutton<sup>x</sup> thinks that the surface waves have no relation to the elasticity of the rock. He says: "Their lengths are too small, their amplitudes too great, and their speeds of propagation too slow to be dependent upon elasticity"; but if we refer to the modulus of elasticity which holds near the surface, and upon the square root of which the velocity of transmission depends, we see that its value becomes very small as the value of  $n$  diminishes and therefore in some alluvium it is quite possible to have slow speeds and short wavelengths, and, as we have seen, large amplitudes. It is not necessary to believe that the amplitudes of surface waves are nearly as large as they appear, for it must be remembered that an observer being shaken by the strong vibrations of a violent earthquake is in a difficult position to make good observations on the phenomena about him, and particularly to distinguish between the movements which are actually taking place and those which he apparently sees, but which are really due to his own oscillations. We have many descriptions of trees and telegraph poles being swayed so violently as nearly to strike the ground, which of course is impossible, as the distortion of the earth necessary to produce this result would have caused disruptions which were not observed; and moreover, a small vibratory movement is sufficient to cause very great commotion among trees, which would naturally be referred by an observer to tiltings due to surface waves.

---

<sup>1</sup> Earthquakes, p. 144.

## THE INFLUENCE OF THE FOUNDATION ON THE APPARENT INTENSITY.

---

### THE GREATER DAMAGE ON ALLUVIUM.

Experience shows that the damage done by destructive earthquakes is much greater on alluvial soil than on solid rock. A glance at the isoseismal map No. 23 will show how well this was exemplified by the California earthquake. Probably the best example we have is the city of San Francisco itself, which is built variously on solid rock, on sand, on natural alluvium, and on "made ground." The description of the destruction done in the city (vol. i, pp. 220-245.; maps, Nos. 18 and 19) shows that within its limits the character of the foundation was a far more potent factor in determining the damage done than nearness to the fault-line. This is not a question of the transmission of vibrations, for, on account of the higher elasticity of solid rock, it would transmit vibrations far better than alluvium, and indeed, as the alluvium occupies limited and comparatively shallow basins in the rock, the vibrations are always transmitted from a distance thru rock; and the question really to be answered is: How are the vibrations modified in a basin of alluvium so as to make them more destructive than without this modification? By analogy the well-known experiment of the ivory balls has been invoked to explain the fact. If the first of a row of ivory balls in contact receives a sharp blow, it transmits the shock to the next ball, but remains almost stationary itself; the shock is thus transmitted from ball to ball, and the last one, having nothing before it, flies off. It is said that the surface of alluvium having nothing above it, and having little cohesion, experiences a much stronger vibration than a rock-surface under similar circumstances. But the analogy does not seem to me a good one, for the lack of constraint of objects above the surface is the same whether we are dealing with rock or with alluvium; and it is only in so far as a lack of cohesion in the alluvium would permit its surface to be thrown into the air that a difference in the two substances might be supposed to make itself evident; but in the cases we are considering, the shock is not nearly strong enough to produce such an effect; and besides, structures built on rock are not usually firmly attached to it; they would be thrown upwards just as easily as tho they rested on alluvium; if subjected, in the two cases, to the same vibratory acceleration.

NOTE. — When a transverse wave, in which the vibrations are parallel with a free surface, is reflected from the surface, the amplitude at the surface is twice as great as that of the incident wave; the amplitude varies periodically with the distance from the surface in such a way that it equals the large surface amplitude at distances of any even number of times  $X/4 \cos i$ ; where  $X$  is the wave-length, and  $i$  is the angle of incidence; and it is zero at distances of any odd number of times the same expression. With transverse waves not parallel with the surface or with longitudinal waves the problem is much more complicated; it would still resemble the simpler case, but the variations of intensity would be less marked. The strong surface motion would extend some distance into the medium; this is probably why observations in mines have shown practically the same intensity of movement as at the surface; the depth of the mines is only a fraction of  $X/4 \cos i$ .

### THE THEORY OF MR. ROGERS'S EXPERIMENT.

With the object of throwing light on this subject, Mr. J. F. Rogers made some very interesting experiments (vol. i, pp. 320-335), in which sand containing various amounts of water and held in a wooden box was caused to vibrate to and fro and the movement of the top of the sand compared with the movement of the box. The outside forces are

applied to the sand either at the base or at the sides of the box and must be transmitted thru the sand. What is the character of this transmission? Evidently it must depend upon the amount of water contained in the sand and also upon the frequency of the vibrations. If the sand is fairly dry and the frequency slow, the sand will act very much as an elastic solid body and we may assume that the successive horizontal layers shear slightly over each other as a solid would do, and that the forces brought into play are proportional to the shear. The movement under these conditions, when we neglect the influence of the sides of the box, would be somewhat like the movement of a flexible rod fastened to the bottom of the box. The rod, however, would be bent with compressions and expansions on opposite sides, whereas the sand is distorted simply by the elastic shear of successive horizontal layers over each other; but the character of the motion in the two cases is very similar. To understand the movements of the sand we must consider the forces acting between the successive layers. The equation of motion of such a system (provided the motion is not too large) is

$$d^2y - n c P''y$$

where  $x$  is measured vertically upwards, and  $y$  in the direction of motion;  $t$  is the time,  $p$  the density of the material, and  $n$  its coefficient of rigidity or shear. The solution of the equation if the column of sand were slightly distorted, and then allowed to vibrate without further disturbance, is

$$y = A \sin \frac{x}{\lambda} \sin \frac{2\pi}{T_0} t \tag{2}$$

where

$$\frac{\lambda^2}{4\rho l} = \frac{n}{\rho}$$

This represents a standing wave, of wave-length  $\lambda$  and period  $T_0$ . The period may have a great number of values, namely:

$$T_0 = \frac{4H}{2m+1} \sqrt{\frac{\rho}{n}} \tag{3}$$

and the corresponding wave-lengths are

$$\lambda = \frac{4H}{2m+1} \tag{4}$$

where  $H$  is the thickness of the sand; and  $2m+1$  is any positive, odd, whole number. Introducing these values in (2) we get

$$y = A \sin \frac{2\pi(2m+1)}{4H} z \cdot \sin \frac{2\pi}{4H} \sqrt{\frac{n}{\rho}} t \tag{5}$$

The longest period with which the system can vibrate is

$$T_0 = 4H \sqrt{\frac{\rho}{n}} \tag{6}$$

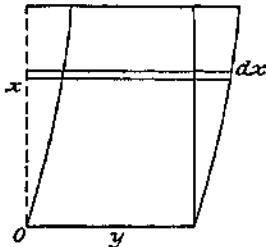

Fig. 25.

but in addition there may be superposed the odd harmonics. For the simplest vibration an originally vertical straight line would be changed into a quarter of a sine curve, as shown in fig. 25. Equation (6) is the expression used on page 39 to determine the free period of vibration of the strained rocks near the fault-plane at the time of the earthquake.

Suppose, instead of vibrating freely, the base of the sand is made to vibrate according to the expression  $B \sin \left( \frac{2\pi}{P} jt \right)$  i.e., with an amplitude  $B$  and a period  $P$ .

The solution of equation (1) under these conditions is

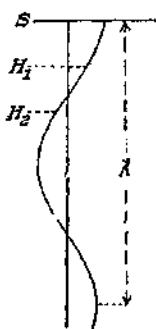

Fig. 26.

$$y = \frac{B}{\cos \frac{2\pi}{\lambda} (x - H)}$$

where  $X$ , the length of a distortion wave of period  $P$  in the sand, supposed of indefinite extent, equals  $\frac{P}{\lambda} \sqrt{\frac{\rho}{\rho}}$ . Equation (7) shows that a vertical straight line in the sand is distorted into a cosine curve with its maximum amplitude at the surface. Fig. 26 shows the form of this curve;  $S$  is the surface and only that part of the curve is followed which lies between  $S$  and the bottom at the distance  $H$  below it. At the surface  $x = H$ , since  $x$  is measured from the bottom, and the amplitude becomes

$$\frac{B}{\cos \frac{2\pi H}{\lambda}} \tag{8}$$

and this varies between  $B$  and infinity, according to the value of the ratio of  $\frac{H}{\lambda}$ . If  $H$  is any even number of times  $\frac{\lambda}{4}$  the denominator becomes 1 and the amplitude becomes  $B$ . If  $H$  is any odd number of times  $\frac{\lambda}{4}$  the denominator becomes 0 and the amplitude infinite. If, instead of varying the depth, we suppose it constant and vary the period of the disturbance, we get similar results. Replace  $X$  in (8) by its value and the surface amplitude becomes

$$\frac{B}{\cos \frac{2\pi \lambda L}{P \sqrt{\frac{\rho}{\rho}}}} \tag{9}$$

The free periods of the system are given by equation (3), and if  $P$  has one of the values there given, the denominator of (9) becomes the cosine of an odd number of times  $\frac{\pi}{2}$ , which is 0, and the amplitude becomes infinite. Practically, of course, friction or a slipping of the sand particles would prevent the amplitude from becoming extraordinarily large.

We see, therefore, from (7), (8), and (9) that the surface would vibrate with the same period as the base and that it would always be in the same or in the opposite phase; that its amplitude would never be less than that of the base and that it would in general be larger and might become indefinitely large when the depth of the sand is an odd number of times a quarter wave-length, a wave-length being determined by the density and rigidity of the mass and the period of vibration; or what amounts to the same thing, when the period of vibration becomes equal to one of the free periods of the system. If, however, the frequency of the vibration should be too great, the bond between the different grains of sand would be broken, and the conditions upon which the above conclusions are based would no longer hold; the sand grains would slip over each other, and the amplitude of the upper surface would be diminished. If we apply the above theory to Mr. Rogers's experiments with dry sand, we find it in close agreement with his results. When the frequency is very low, the sand moves with the box; in terms of the theory, we are dealing with only the upper part of the curve in fig. 26, and since  $H$  is very small in comparison with  $X$  the surface amplitude as given by (8) becomes  $B$ , the amplitude of

the base. As the frequency increases the wave-length,  $X$ , decreases, and the surface amplitude increases; we have to do with a longer part of the curve in fig. 26. When the frequency becomes too large, the surface amplitude begins to decrease, suggesting that the sand no longer acts as a solid, but that slipping takes place. The addition of a small amount of water to the sand diminishes the cohesion between the grains, which reduces the value of the coefficient of rigidity,  $n$ , and shortens the wave-length, for a given frequency; we therefore get larger surface amplitudes, but slipping occurs at lower frequencies than with drier sand. As the sand is probably only able to bear a definite shearing force without slipping, an increase in the amplitude of vibration would cause the slipping to begin at a lower frequency than with smaller amplitudes. The conclusions are in good accord with Mr. Rogers's results as shown graphically in his figs. 62 and 63.

When, with increasing frequency, the slipping first begins, it must take place only at the ends of the strokes where the acceleration, and therefore the force, is greatest; but as the frequency gets still higher, the slipping is spread over a greater and greater part of the stroke and the surface amplitude becomes less and less; the mathematical theory we have sketched out does not apply after slipping begins.

So far we have considered the motion as communicated to the sand from the bottom of the box and not by the pressure of the sides, which would undoubtedly modify it, but the results given by Mr. Rogers are for the sand near the middle of the box where the sides have the least influence; and in one experiment where the sand was piled up on the bottom of the car without touching the sides, the results were not altered; it appears therefore that in the case of sand which is not too wet, and for frequencies not high enough to cause slipping, the influence of the sides has not been great enough to alter the general character of the motion of the sand in the middle of the box; but near the sides their influence causes much confusion in the motion of the sand.

When the sand is thoroly soaked with water, it becomes very plastic, the elastic forces become very small and viscous forces become the predominating forces between the successive layers. We therefore determine what is the character of the motion transmitted from the bottom by means of viscous forces. We find that transverse waves are set up which advance to the surface and are there reflected back again. These waves have a wave-length dependent upon the density of the material and the viscosity, and are very quickly damped out. Indeed, the amplitude of the advancing wave is reduced to less than  $1/500$  of its original value at a distance of one wave-length from the base, and the reflected wave starts with a small amplitude and dies out very rapidly. We find that the amplitude at the surface is always less than that at the base and that its value is twice as great as that of the direct wave at the surface if it were not reflected; that is, if the depth of the sand were one wave-length the amplitude at the surface would be about  $1/250$  of the amplitude at the base, instead of about  $1/500$ , as in the case of no reflected wave. It is quite evident that waves of this character could not explain the movement of the wet sand in the experiment; and we therefore turn our attention to the influence the sides of the box would have on the motion of a fluid as viscous as the mixture must be. As Mr. Rogers says, the damping is so great that the mixture could not have a free period of its own. The experiment described in vol. i, pp. 328 and 329, and illustrated by fig. 61, shows very well the character of the motion, namely, that the surface material moves very steadily during the greater part of its excursion with a fairly uniform velocity, somewhat greater than that of the base, and that its velocity is rapidly reversed at the end of the stroke. This being the case we conclude that there is little force acting upon the sand except near the ends of its excursion and that there a strong force acts for a short time. It seems probable, therefore, that as the box diminishes in velocity towards the end of the stroke the sand, by its inertia, is carried forward and raises the mixture in

front of it against the side of the box; this together with the return movement of the box produces a strong force which quickly reverses the movement of the sand, giving it a velocity slightly greater than the maximum velocity of the box; but the force is not active again until the box approaches its maximum displacement on the other side. The movement therefore depends upon the action of the sides of the box and is not transmitted from the bottom. It is clear from Mr. Rogers's experiments that the forces when the sand is dry are very different from those when the sand is very wet; and when different parts of the sand contain different amounts of water, that the movements would be so different as to produce much confusion.

#### APPLICATION OF THE THEORY TO SMALL BASINS.

When we attempt to apply the results of the experiments to explain the case of the greater disturbance in alluvial soil than in rock, we recognize with Mr. Rogers that it is dangerous to carry analogy from such small quantities to such large masses, and we must be very carefully guided by theory if we wish to avoid great error.

As already noted, alluvium occupies basins in the rock of more or less extent, and in considering its motions we must divide the basins into two classes; the first comprises those basins which are small enough, in the direction of propagation, for all parts to move practically in the same phase, like the box in Mr. Rogers's experiments; that is, they must be not much larger than an eighth of the wave-length of the waves in the surrounding rock. With waves whose period is as short as a half second, the basins may be somewhat more than a quarter mile across; but with periods as long as 10 seconds, they may be over 5 miles across, and still be in this class. The second class comprises all large basins, where the progressive character of the wave-motion must be considered.

Where alluvial basins are not extremely small, they are always much broader than they are deep, usually many times as much; and they are also saturated with water. When the material is largely sand or gravel, the grains are held so closely together by the weight of the material lying above them that the vibrations can be transmitted from the bottom in the same way as with dry sand; but when the material is soft mud, transverse vibrations can not be so transmitted and the influence on the sides becomes predominant. The limiting case of fluidity is exemplified by streams, ponds, and even vessels containing water or milk, where the liquid may be so greatly agitated as to be splashed out on the sides. Mr. Rogers's experiments seem to explain pretty satisfactorily the larger surface amplitude and the greater damage done in the class of small basins of alluvium; but it must be noted that the basins have not a flat bottom like a box, but have rather an open V shape, like stream valleys; and there is no abrupt distinction between the bottom and the sides. Where the material is sufficiently solid, the vibrations are transmitted both as transverse and longitudinal vibrations from the bottom, the surface amplitude being in general greater than at the base and varying with the depth, the coefficient of rigidity, and the period of the vibration; the depth of a basin is more or less irregular, the character of the material, and therefore the coefficient of rigidity, varies from point to point; therefore the amplitude will vary from point to point on the surface, and points not far apart may be even in opposite phases, so that more or less discordant movements take place. The commotion may be sufficiently great to produce cracks in the ground, especially at the boundaries of softer and firmer material. The damage to buildings is due more to the discordant character of the disturbance than to the mere increase in amplitude at the surface of the alluvium, for deep pilings with a strong concrete capping diminish the damage to a remarkable degree; the capping must move nearly as a rigid body and relieve the building above it from different movements in different parts of its foundation. The capping must also diminish the amplitude, for movements in opposite direc-

tions of neighboring parts of the alluvium would be nullified by it. When the alluvium is so soft and plastic that shearing forces are insignificant, the alluvium is flung back and forth by the reaction of the sides of the basin with effects apparently still worse than in the former case; and with the formation, near the sides, of elevations and depressions resembling wave-surfaces; but they are not true progressive waves, for the rigidity is too small for the surface waves described on page 47 to be formed; and the viscosity is too great to permit of gravitational waves, but the violent to-and-fro motion of the basin and the low rigidity produce, near the sides, elevations resembling a wave surface, and the motion of the soft alluvium is so quickly damped out by its viscosity that the form is fixed and remains after the disturbance is over. This condition was characteristic of the small filled-in swamps of San Francisco, usually accompanied by a general lowering of the surface, due to the character of the refuse used for filling them; this material was so little consolidated that the surface has been steadily sinking for years (vol. i, pp. 241-242), and its volume was materially reduced by the shaking of the earthquake.

#### LARGE BASINS.

The second class of alluvial basins are those which are too large to be looked upon as moving as a whole; that is, they are larger than an eighth wave-length; in some cases they are many wave-lengths in breadth. They are represented in California by the large valleys, the Santa Clara, the San Joaquin, etc. We must picture them to ourselves as broad, shallow basins with irregular floors and containing material whose coefficient of rigidity varies considerably even in neighboring parts; this material is principally water-soaked sands and gravels, given a certain amount of rigidity by the weight of the material above it. As the elastic waves pass thru the underlying rock they enter the alluvium and are refracted upwards on account of the smaller velocity in the alluvium than in the rock. If the angle of incidence is sufficiently small, the amplitude of vibration in the alluvium will be larger than in the rock; for instance, if we assume the density of the alluvium to be 0.8 that of the rock, and the velocity of propagation one-fifth as great, then for normal incidence the amplitude of the refracted wave in the alluvium would be nearly double that of the incident wave in the rock, both for compressional and for distortional waves. After entering the alluvium the waves would be reflected back and forth from the surface and bottom until they were damped out by the viscosity of the alluvium; for normal incidence the amplitude of the wave reflected from the bottom would be fifteen-sixteenths that of the incident wave, and then a large part of the motion would be kept in the alluvium. When the angle of incidence from the rock to the alluvium is greater than zero, two reflected and two refracted waves are produced; and when this angle is not large the refracted wave in the alluvium would still have a larger amplitude than the incident wave in the rock. When reflected at the surface, the wave would have its phase changed by half a period, and if the length of its path to the floor and back again were a half wave-length, it would find itself in the same phase as the direct wave when it again reached the surface, and the resulting amplitude would be the sum of the amplitudes of the two waves. In many parts of the basins this relation of depth to wave-length must approximately have existed for some of the waves present in the earthquake disturbance. Repeated reflections would probably result in a surface amplitude considerably greater than would occur at the surface of continuous rock; and the irregularities mentioned above would cause discordance of motion at points near together, and thus greatly increase the damage.

A thin coating of alluvium over the rock would evidently move with the rock and would not have an especially large amplitude; it would be necessary for its depth to be something like an eighth of a wave-length to obtain the full effect; the small velocities

of transmission in alluvium would allow this condition to be satisfied even with a much smaller depth than was found in many parts of the large Californian valleys.

Surface waves would also be a strong factor in causing damage on alluvium; these waves and the irregularities due to varying coefficients of elasticity are probably the principal causes of the increased damage on alluvial soils, even when of sufficient thickness to experience the accumulated amplitudes described above.

The sides of the basins would exert no special influence except in their immediate neighborhood; but a certain amount of irregular reflection and refraction there would probably cause unusual intensity at some points.

THE FOUNDATION COEFFICIENT.

At Professor Lawson's suggestion I have attempted to find some quantitative relation between the intensity of the shock on sands, marshy land, and solid rock.

We shall first consider small basins within the limits of San Francisco. If we look at the profiles drawn by Mr. Wood and reproduced in map 18, we find the following estimates of the accelerations (a column has been added to the table giving the ratios of the accelerations on the various materials to that on the most solid rock. I have called this ratio the *foundation coefficient*):

TABLE 4. — *The Foundation Coefficient (San Francisco).*

SECTION.	FOUNDATION.	ACCELERATION mm./sec. <sup>2</sup>	FOUNDATION COEFFICIENT.
EF	Serpentine.	250	1.0
EF	Made land.	1,100	4.4
EF	Marsh.	3,000	12.0
CD	Sandstone	250 to 600	1 to 2.4
CD	Made land.	2,900	11.6
CD	Sand.	600	2.4
CD	Sandstone.	400	1.6
AB	Sand (Mission Valley)	1,100	4.4
AB	Marsh.	3,000	12.0
AB	Sundry solid rocks	250	1.0

These observations are not all entirely independent; for instance, the marsh indicated in the first and last sections is the same marsh, as these two sections go thru it; and the first two sections cross on the sandstone of Telegraph Hill. The high intensity at the southwestern extremity of section *AB* has not been considered because it is too near the fault; nor has the local strengthening of the intensity near the middle of section *CD*, which apparently is not to be explained merely by the nature of the terrane at these points. The very low intensity of only 250 millimeters per second per second on solid rock indicates a smaller intensity in San Francisco than further north, where we should have to go at least three times as far from the fault-line to find the intensity so low. The table, which gives only a very rough approximation to the coefficients, shows that the damage on small marshes may represent an acceleration as much as 12 times as great as on solid rock; on made land, from 4.4 to 11.6 times as great; on loose sand, from 2.4 to 4.4; and on sandstone, from 1 to 2.4. Altho it has been well known that the apparent acceleration on soft land is much greater than on rock, the ratios obtained seem very much greater than had been suspected.

The following table gives a list of places on alluvial soil in basins of considerable size, too large to be considered *small* basins, in the sense we have used that word.



TABLE 5.—*The Foundation Coefficient (Distant Points).*

PLACE.	EOSSI-FOBBL SCALE.		ABSOLUTE SCALE.		FOUNDATION COEFFICIENT.
	Apparent Intensity.	General Intensity.	Apparent Intensity.	General Intensity.	
Salinas . . . . .	IX	IV+	2,000	125	16
San Jose . . . . .	IX	VII?	2,000	300	7
Santa Rosa . . . . .	X	VIII	2,500	1,200	2
Ukiah . . . . .	VIII	VII	1,200	250	5
Willits . . . . .	IX	VII	2,000	250	8
Clear Lake . . . . .	VIII	VI	1,200	200	6
Priest Valley . . . . .	VII	IV*	-300	100	3
Sacramento . . . . .	VI*	V*	200	125	2
Los Banos . . . . .	IX		200	125	16
West San Joaquin Valley	VIII +	<b>IX</b>	1,600	125	12

The intensities are given both in the Rossi-Forel scale and in the absolute scale of accelerations; the first column under each scale gives the *apparent* or felt intensity, and the second gives the *general* intensity or what seemingly would have been felt on solid rock if it had existed there. To determine the general intensity requires the exercise of some judgment, guided of course by the intensity map, No. 23; this quantity therefore is subject to considerable error. The same is true of the values in the absolute scale; we have used Professor Omori's estimates of the absolute values of the Rossi-Forel scale for intensities of VII or more \* and Professor Holden's estimates for the lower intensities.<sup>2</sup> The difficulties of obtaining the correct intensities, apparent and general, according to the Rossi-Forel scale, and the further difficulty of translating into the absolute scale, on account of the larger difference between the successive degrees of higher numbers of the former scale, make the values obtained only approximate; therefore it must be recognized that the foundation coefficients are far from accurate.

The regions about Sacramento, Santa Rosa, and Priest Valley seem to have had their intensities increased least of all the alluvial basins. The great destruction of Santa Rosa suggested a special disturbance in that region, but this seems entirely unnecessary in view of its low coefficient in the table. The Salinas and San Joaquin Valleys have exceptionally high coefficients. The value at Salinas is probably accounted for by the extremely loose character of the alluvium in the flood-plain of the river and its nearness to the fault; but the low value at Sacramento suggests that a similar explanation may not be satisfactory for Los Banos and the San Joaquin Valley; and the high intensity the whole length of this valley has suggested an auxiliary fault in the region. The fact that the greatest northeastern extension of the lower isoseismals is not opposite the center of the known fault, but almost opposite its southern end; and the extension of the same isoseismals to the southeast, where they are more nearly symmetrical with respect to the San Joaquin Valley than with respect to the known fault, support the view of an auxiliary fault in or near this valley. On the other hand, it is quite possible that the intensity in the valley has been overestimated, and that the alluvial character of the ground may account for the intensity that actually existed there. I am inclined to think an auxiliary crack the best explanation of the high intensity in the San Joaquin Valley; but the evidence for it is by no means satisfactory. (See further, vol. i, pp. 344, 345.)

The great differences in the coefficients found for the different alluvial basins are much too great to be accounted for by inaccuracies in their determinations; we must conclude that there are differences in the character and in the depth of the alluvium in different basins, and probably even in different parts of the same basin, which are important factors in the values of the coefficients.

<sup>1</sup> Publications of the Earthquake Investigation Commission in Foreign Languages, No. 4.  
<sup>2</sup> Dutton's Earthquakes, p. 128.

PART II

INSTRUMENTAL EFFECTS OF THE EARTHQUAKE

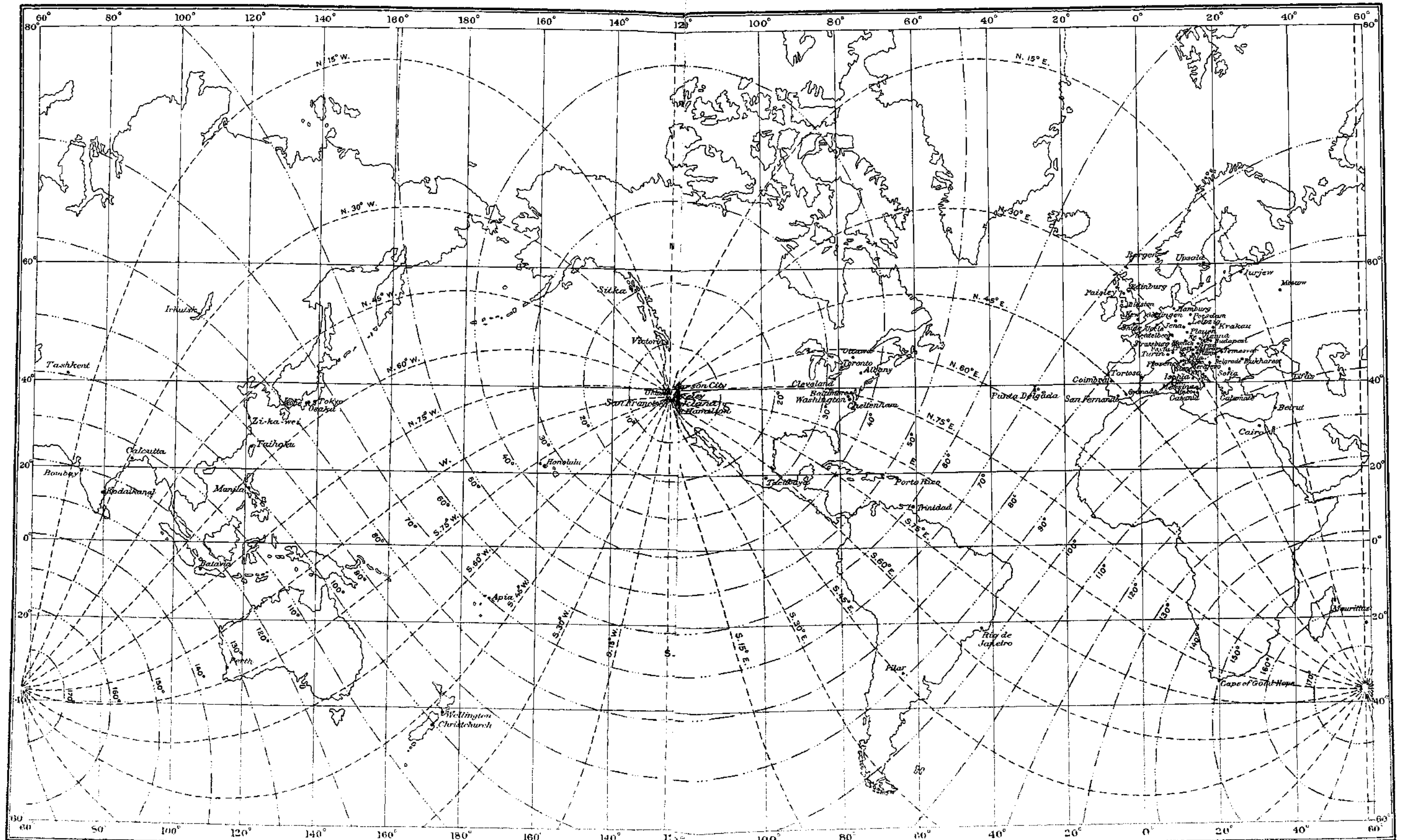

MAP SHOWING DISTANCES AND DIRECTIONS FROM THE ORIGIN OF THE SHOCK

## COLLECTION AND REPRODUCTION OF THE SEISMOGRAMS.

The intensity of the shock was so great that practically all seismographs, situated in any part of the world, recorded it. Shortly after the earthquake letters were addressed to all the seismological observatories in the world asking for copies of their seismograms and other necessary data, and the Commission takes pleasure in expressing its thanks to the directors of the various observatories, who were kind enough to send reports and either their original seismograms or copies, which have been reproduced in the Atlas. A few, however, were too faint for reproduction and have been omitted.

In the great majority of cases, copies of the seismograms, and not the originals, were sent; and it was not thought necessary to reproduce them in facsimile, especially as the International Seismological Association has recently reproduced in facsimile the seismograms of the Valparaiso and Aleutian earthquakes of August 16, 1906. A very careful tracing was therefore made of each seismogram and this was reproduced by photolithography. Some of the seismograms, especially those made by Milne instruments, do not lend themselves to this method, and they have been reproduced by a gelatin process. Some of these were too faint in places to yield good reproductions; they were accordingly slightly strengthened, the draftsman keeping well in view the character of the instrument and being guided by the marginal records, so that the true form of the central record has been preserved.

Great care has been given to all reproductions, and the characteristics of the various seismograms have been well brought out.

In printing the seismograms those recording times are so placed that the time increases from left to right; it has not always been possible also to make the time increase from top to bottom, but an arrow has been placed at the beginning of the record so that this part can readily be found. In most cases the times are given in Greenwich mean civil time (G. M. T.), 0 hours beginning at midnight. Where a correction is necessary or where local time is used, the correction to reduce to G. M. T. is given under the seismogram, the total correction is always given, including the error of the clock, the parallax of the recording stylus, and the correction for longitude where local time was used.

The seismograms are reproduced in their original size, except in a few instances, which are noted. These were cases in which they were extremely large and the copies supplied were from hand tracings, so that nothing was lost by the reduction; or cases in which the copies were already reduced. The seismograms on sheets 1 and 2 have been inadvertently reduced about 2 per cent; but this is unimportant. It was desired to arrange the seismograms in the order of their distances from the origin, but on account of the two different methods of reproduction, and the greater number of plates this plan would require, it was given up and the seismograms arranged so as to make the smallest possible number of plates. The seismograms from any station can readily be found from the list of observatories, from the contents, or from the table of contents of the Atlas.

## OBSERVATORIES AND THE DATA OBTAINED.

In the following list the observatories are arranged in the order of their distances from the origin of the disturbance, and the map, plate 1, shows their positions graphically; it also shows their distances from the origin and the courses followed by the earthquake waves.<sup>1</sup> The distances of the stations are calculated along the arc in degrees and in kilometers, and along the chord in kilometers. In calculating these quantities the ordinary trigonometrical formulæ are used. The earth is considered spherical with a radius of 6,370 km.; which gives 111.18 km. for the length of one degree of arc. (We can readily convert kilometers into miles by multiplying by 1.6L) In the collection of data all information available aiding in the interpretation of the seismograms is given. Although other instruments in the same observatory may have recorded the shock, only those whose records were obtained are mentioned; and all their constants, so far as possible, are given. The component indicated refers to the direction of the earth vibrations recorded; for instance, a horizontal pendulum in the meridian would record the east-west component. The abbreviations used have the following meanings:

*T*, the complete period of the pendulum without damping.

*V*, the magnifying power for very rapid vibration.

*J*, the indicator length, as used by Professor Wiechert. It is the product of the length of the simple mathematical pendulum, having the same period, multiplied by the magnifying power, *V*. Its value is therefore  $(T/2\pi)^2 g V$ . It is also given by  $a/a$ , where *a* is the displacement of the pointer due to a tilt, *o*, of the ground. On account of friction these two values do not always agree. The value obtained by the first method is given; and

*Angular displacement* gives the displacement of the pointer due to a tilt.

*L*, the distance of the center of oscillation from the axis of rotation; it equals the length of a mathematical pendulum of the *same type*, as defined on page 155.

*V*, the length of the simple mathematical pendulum having the same period. Its value in meters is practically the square of half the period in seconds.

*M*, the mass of the pendulum.

*e*, the damping ratio of the vibrations.

*r*, the frictional displacement of the medial line, as defined on page 163, and shown in fig. 43.

In the majority of cases the values of the constants, or data sufficient to calculate them, have been supplied by the director in charge of the instrument; in the case of the Milne or the 10-kilogram Bosch-Omori instrument, the values of some of the constants could be obtained from exactly similar instruments installed in Baltimore. The value of *L* for the Wiechert inverted pendulum is taken from Dr. Etzold's report on the Leipzig instrument. The times of the arrival of the different components at the station as recorded by the various instruments refer to the *first preliminary tremors*, the *second preliminary tremors*, the *regular waves*, the *principal part*, and the *maximum disturbance*. The hour is usually omitted as unnecessary; when the times are reported in minutes and seconds, they are indicated thus, 21<sup>m</sup> 43<sup>s</sup>; when they are reported in minutes and tenths of minutes they are indicated thus, 21.7<sup>m</sup>. The *interval* of time required for the waves to reach the station is given by subtracting the time of the shock, 12<sup>m</sup> 28<sup>s</sup> or 12.5<sup>m</sup>, from the time of arrival. The *amplitude* is the displacement of the pointer from its position of equilibrium measured on the seismogram in millimeters, and always refers to the maximum disturbance unless it stands opposite some other time. The *earth's amplitude* is the corre-

<sup>1</sup> ERRATA. — Two of the stations have been slightly misplaced. Kodaikanal, Madras, should be about 2.5 mm. north of the southern end of India and about equally distant from the sea to the east and west. Mauritius should lie in the southeastern angle between the line marking 20° S. latitude and the red north-south line thru the antipodes of the origin, and practically touching these lines.

sponding displacement of the earth. The *'period'* relates to the period of the earth-waves as recorded on the seismogram, and not to the natural period of the pendulum. Some of the times and other quantities relating to the records were sent by the directors of the various observatories, some were extracted directly from the seismograms. A discussion of any special characteristics which a seismogram may have follows the records of each station.

Usually different instruments at the same station give somewhat different times for the arrival of the various phases. The cause of these differences is not known and the average has been taken as the record of the station. In a few cases some instruments have evidently been late in responding to the disturbance; their records have been disregarded.

The *direction* of a station is the angle at the origin between the meridian and the great circle passing thru the origin and the station.

In order more readily to find the data of any particular station the following alphabetical list refers to the records and the seismograms.

*List of Observatories.*

STATION.	PAGE.	SEISMOGRAM, SHEET No.	STATION.	PAGE.	SEISMOGRAM, SHEET No.
Agram (Zagreb), Hungary	93	...	Messina, Italy	100	12
AJameda, California	63	3	Mizusawa, Japan	73	...
Albany, New York	71	8	Moscow, Russia	84	...
Apia, Samoa	72	...	Mount Hamilton, California	64	"3
Baltimore, Maryland	71	1	Munich, Germany	85	5
Batavia, Java	106	15	Oakland, California	62	3
Belgrade, Servia	97	...	O'Gyalla, Hungary	91	...
Bergen, Norway	74	...	Osaka, Japan	76	"15
Berkeley, California	62	3	Ottawa, Canada	69	10
Bidston, England	75	1	Paisley, Scotland	73	1
Bombay, India	105	2,15	Pavia, Italy	88	7
Budapest, Hungary	91	...	Perth, Western Australia	106	2
Caggiano (Salerno), Italy	99	...	Pilar (Cordoba), Argentina	95	1
Cairo (Helwan), Egypt	104	1	Pola, Austria	94	...
Calamate, Greece	102	15	Ponta Delgada, Azores	73	"i
Calcutta, India	105	1	Porto Rico (Vieques)	71	8
Cape of Good Hope, Africa	107	1	Potsdam, Germany	81	4,5
Carloforte, Sardinia, Italy	97	...	Quarto-Castello (Florence), Italy	94	6
Carson City, Nevada	65	"3	Rio de Janeiro, Brazil	101	...
Catania, Italy	101	13	Rocca di Papa, Italy	96	14
Cheltenham, Maryland	70	8	Sal6, Italy	89	...
Christchurch, New Zealand	103	...	San Fernando, Spain	85	"i
Cleveland, Ohio	68	"3	San Jose, California	63	3
Coimbra, Portugal	82	1	Sarajevo, Bosnia	97	15
Dorpat (Jurjew), Russia	78	10	Shide, England	76	7,12
Edinburgh, Scotland	74	1	Sitka, Alaska	66	11
Fiume, Hungary	92	...	Sofia, Bulgaria	100	13
Florence (Ximeniano), Italy	93	"Q	Strassburg, Germany	84	14
Florence (Quarto-Castello), Italy	94	6	Tacubaya, D. F., Mexico	67	9
Göttingen, Germany	81	12	Tadotsu, Japan	104	...
Granada, Spain	87	14	Taihoku, Formosa	99	"is
Hamburg, Germany	78	...	Taschkent, Turkestan	102	2,13
Honolulu, Hawaiian Islands	68	2	Tiflis, Russia	102	...
Irkutsk, Siberia	79	2,2a,13	Tokyo, Japan	74	"i
Ischia (Grande Sentinella), Italy	98	7	Toronto, Canada	68	...
Ischia (Porto d'Ischia), Italy	98	7	Tortosa, Spain	86	...
Jena, Germany	83	11	Triest, Austria	90	...
Jurjew (Dorpat), Russia	78	10	Trinidad, West Indies	72	...
Kew, England	77	1	Uccle, Belgium	78	2a
Kobe, Japan	77	5	Upsala, Sweden	75	9
Kodaikanal, India	106	2	Urbino, Italy	95	...
Krukau, Austria	87	13	Victoria, British Columbia	66	"i
Kremsmünster, Austria	86	2	Vienna, Austria	89	9
Laibach, Austria	90	...	Washington, District of Columbia	69	8
Leipzig, Germany	82	...	Wellington, New Zealand	102	2
Los Gatos, California	64	3	Yountville, California	62	3
Manila, Philippine Islands	103	4	Zagreb (Agram), Hungary	93	...
Mauritius	107	2	Zi-ka-wei, China	95	15

## BERKELEY, CALIFORNIA.

Students' Astronomical Observatory of the University of California. Prof. A. O. Leuschner, director.  
 Lat.  $37^{\circ} 53' N.$ ; long.  $122^{\circ} 16' W.$ ; altitude, 97 meters; distance,  $0.46^{\circ}$  or 51 km.; direction, S.  $68^{\circ} E.$   
 Foundation, solid rock.  
 Seismograms, sheet No. 3.

The instruments used were (1) Ewing three-component seismograph, (2) Ewing duplex pendulum, V, 4. The recording plate of the three-component seismograph was raised off its bearings and failed to revolve, and the brackets recording horizontal motion were so disarranged that no reliable record was made; but the weight recording vertical motion showed a maximum displacement just within the range of the instrument, namely, 76 mm., and as the magnifying power was 1.7, and the friction so great that it was practically dead-beat, we may fairly conclude that the maximum vertical range of the ground was about 45 mm., and the amplitude half as much.

The duplex pendulum record is greatly confused and much affected by the stops which limit the displacement of the pendulum; but by a careful study of a greatly magnified record, Professor Leuschner has succeeded in working out the early part of the motion which is reproduced separately on the left of the complete seismogram. The directions on the seismograms show the directions of the earth's movements. As the magnifying power is 4, we see that there was first a movement of the earth of 4.5 mm. towards the east, that is, away from the origin, followed by a movement of 6.5 mm. to the north. It then swung towards the west and back to the southeast. The character of the movement from this point can be more easily understood from the seismogram than from a verbal description; it is soon lost in the confused record which shows a great deal of irregularity; this must, however, partly be due to the influence of the stops which limit the movements of the pendulum. The stops limited the motion so that an earth-amplitude of only 11 mm. was recorded, far less than was actually experienced.

## OAKLAND, CALIFORNIA.

Chabot Observatory. Prof. Charles Burckhalter, director.  
 Lat.  $37^{\circ} 48' N.$ ; long.  $122^{\circ} 17' W.$ ; altitude,  $4 \pm$  meters; distance,  $0.48^{\circ}$  or 53 km.; direction, S.  $59^{\circ} E.$   
 Foundation, alluvium.  
 Seismograms, sheet No. 3.

The instrument used was a Ewing duplex pendulum, V, 4. The seismogram is too confused to give details; but we see clearly that the movement of the pendulum was limited by the nature of the instrument; the movement seems to have been in nearly all directions, and more or less irregular, tho this irregularity was undoubtedly in part due to the pendulum's striking against the side of the case. The beginning of the movement can not be made out on the seismogram. The earth-amplitude recorded is only 10 mm., much less than was actually experienced.

## YOUNTVILLE, CALIFORNIA.

Veterans' Home. F. M. Clarke, superintendent.  
 Lat.  $38^{\circ} 24' N.$ ; long.  $122^{\circ} 22' W.$ ; altitude, 50 meters; distance,  $0.49^{\circ}$  or 54 km. direction, N.  $45^{\circ} E.$   
 Foundation, alluvium over trachite.  
 Seismograms, sheet No. 3.

The instrument used was a simple pendulum about a meter long, the bob weighing 8.15 kg. A long pin passes freely thru a vertical hole in the middle of the bob and records on smoked glass below, with very little friction.  $V, 1.1 \pm$ .

The reproduced seismogram represents the record as it was made by the pendulum. If the pendulum had remained stationary, the movements of the earth would have been just opposite to the recorded movements of the pendulum; but the record is complicated by the free swinging of the pendulum, which was subjected to little friction. The beginning of the movement can not be determined from the seismogram; but from observation of a swinging electric light Mr. Clarke reports it as north to south. The seismogram shows a movement in the northwest-southeast quadrants with a fairly uniform amplitude of 25 mm. The direction of the pendulum's swing changes, but shows little rotatory motion. Singularly, there is no large motion in the northeast-southwest quadrants, the motion in this direction being represented by an elliptic swing with its long axis directed to the northeast, but with only one-third the amplitude of the larger motion. The smallness of the friction, and the lack of exact information regarding the period of the waves, make it impossible to determine the true amount of the earth's motion.

Mr. Clarke gives the following account of the disturbance:

"The first motion was a tremor that swiftly increased in intensity from north to south, and was quickly compounded into a twisting motion accompanied with severe upward thrusts, a 'churning motion.' Then followed a jerky easterly and westerly motion, without the upward thrust, and again the twist; at the end the motion seemed to be southeasterly and northwesterly. Houses were jerked upward. Chimneys were thrown down at the latter part of the shock."

It is curious that the pendulum did not indicate more clearly the existence of rotatory motion; and it is still more curious that there was so little motion in a northeasterly direction, the direction of propagation of the disturbance.

#### ALAMEDA, CALIFORNIA.

Mills College Observatory. Prof. Josiah Keep, director.

Lat.  $37^{\circ} 47' N.$ ; long.  $122^{\circ} 11' W.$ ; distance,  $0.55^{\circ}$  or 61 km.; direction, S.  $61^{\circ} E.$   
Seismograms, sheet No. 3.

The instrument used was a Ewing duplex pendulum; mechanical registration on smoked glass;  $V, 4.$

The seismogram shows a confused record with the beginning undetermined. The marking point has jumped and must have been caught beyond the glass plate, as the record is evidently incomplete. The recorded amplitude corresponds to an earth-amplitude of 10 mm., but it must have been much greater.

#### SAN JOSE, CALIFORNIA.

University of the Pacific. Prof. J. Culver Hartzell.

Lat.  $37^{\circ} 20' \pm N.$ ; long.  $121^{\circ} 55' \pm W.$ ; altitude,  $25 \pm$  meters; distance,  $1.01^{\circ}$  or 112 km.; direction, S.  $45^{\circ} E.$

Foundation, alluvium.

Seismograms, sheet No. 3.

The instrument used was a Ewing duplex pendulum,  $V, 4.$

The beginning of the movement is probably contained in the blur near "W," but it is impossible to determine in what direction the pointer moved from this spot; the pointer must have caught, for the seismogram evidently represents but a small part of the disturbance. The recorded amplitude corresponds to an earth-amplitude of 10 mm.; but it must have been much greater.



## LOS GATOS, CALIFORNIA.

Private observatory. Irving EL Snyder.  
 Lat.  $37^{\circ} 14' N.$ ; long.  $121^{\circ} 59' W.$ ; distance,  $1.04^{\circ}$  or 115 km.; direction, S.  $38^{\circ} E.$   
 Foundation, on soil not far from solid rock.  
 Seismograms, sheet No. 3.

The instruments used were Rocker seismographs. Two lead bars are each supported at the center of two thin circular segments, so that they rock easily on a smooth plate, one in a north-south, and one in an east-west direction. The movements of these rockers are recombined by means of levers and a record is made on smoked glass entirely analogous to the records of a Ewing duplex pendulum. The movement of the earth was magnified about four times.

The arrows show the directions of the motions. If the marking point is supposed stationary, it would be necessary to interchange the directions north and south, east and west, in order to represent the true movement of the earth. The movement seems to have begun in the blurred mark near the middle of the seismogram and the first distinct movement of the pointer was towards the west, and therefore the first distinct movement of the earth was towards the east. This was followed by movements in various directions; the violence of the disturbance quickly disarranged the rockers, and the record is very incomplete. The recorded earth-amplitude is only 5 mm.; but this was much less than the real maximum.

## MOUNT HAMILTON, CALIFORNIA.

Lick Observatory. Prof. W. W. Campbell, director.  
 Lat.  $37^{\circ} 20' N.$ ; long.  $121^{\circ} 39' W.$ ; altitude, 4,210 meters; distance,  $1.16^{\circ}$  or 129 km.;  
 direction, S.  $53^{\circ} E.$   
 Foundation, solid rock; the observatory is on the summit of Mount Hamilton.  
 Seismograms, sheet No. 3.

The instruments used were: (1) Ewing three-component seismograph;  $V$ : north-south component, 4.2; east-west component, 4; vertical component, 1.8. The reproduced seismogram is only half the size of the original and therefore it only magnifies the displacements half as much as indicated above.

(2) Ewing duplex pendulum,  $V$ , 4. In reading the actual movement of the ground from the duplex record we must interchange the directions east and west. Both instruments record on smoked glass. The duplex record shows that the earth first moved for a distance of 7 mm. in a direction S.  $60^{\circ} E.$ ; that is, away from the origin; this was followed with some irregularity, by several vibrations parallel with this direction, with increasing amplitude, and then the movement became confused; there was much jumping of the pen, and as much of the movement was not recorded, the pen must have been held off the plate. Unfortunately we can not say positively when the movement recorded on this instrument began, but its amplitude makes it most probable that it began at the same time as the record on the other instrument, namely at  $5^h 12^m 45^s$ .

Altho the earthquake was first felt at Mount Hamilton at  $5^h 12^m 12^s$ , the Ewing three-component seismograph was not set in motion until  $5^h 12^m 45^s$ ; that is, it was started by the violent shock. This was the nearest instrument to the centrum that was driven by a clock and which separated the various phases of the shock. We note that for 9 seconds the disturbance was comparatively slight and then came the strong movement which carried the pens beyond the limits of the glass plate. The north-south component was soon caught and, with the exception of one spasmodic swing across the plate, did not record again for 1 minute 40 seconds, by which time the disturbance had very much diminished. The east-west component seems to have been better placed, for altho

the pen swung well off the plate, it does not seem to have been caught for more than a few seconds at a time. The vertical component recorded but little even during the earlier phase, and when the heavy shock began, 9 seconds after the beginning, it was so deranged that it became permanently caught and incapable of vibrating, so that its record is simply a circle on the plate. The seismogram shows that there were at first two complete vibrations in a direction about northwest and southeast; the period of the first was about 1 second, that of the second about 4 seconds. The first movement was towards the southeast and amounted to 7 mm.; the second movement in that direction was twice as far. The vertical movement was first upward and amounted to about 15 mm.; the period was about twice as long as that of the horizontal motion. But this may be due to derangement by the shock. This shows quite clearly that the first movement of the ground was directed away from the origin of the shock.

At the beginning of the strong motion, at 5<sup>h</sup> 12<sup>m</sup> 54<sup>s</sup>, the vibration had a period of about 2 seconds which soon increased to 4 or 5 seconds and, at times, was even as great as 10 seconds. The north-south component, as recorded at 5<sup>h</sup> 13<sup>m</sup> 12<sup>s</sup>, shows an earth-amplitude of 4 cm. The maximum east-west amplitude recorded was about the same. The beginning of the strong movement was directed towards the northwest.

#### CARSON CITY, NEVADA.

Carson Observatory. Prof. C. W. Friend, director.<sup>1</sup>

Lat. 39° 10' N.; long. 119° 46' W.; altitude, 1,420 meters; distance, 2.62° or 291 km.; direction, N. 64° E.

Seismograms, sheet No. 3.

The instrument used was a Ewing duplex pendulum, V, 4.

Altho the seismogram shows movements in all directions, it differs very materially from the seismograms of similar instruments nearer the origin. We do not find the sudden and irregular changes in direction, but the changes are rather gentle. At this distance from the origin the disturbance had become a gentle swing with a period of about 3 seconds.

Professor Friend gave the time of arrival of the disturbance as 5<sup>h</sup> 12<sup>m</sup> 25<sup>s</sup>. This is 3 seconds before the occurrence of the heavy shock; and we are led to the inquiry whether it may not refer to the earlier light disturbance, which occurred at 5<sup>h</sup> 11<sup>m</sup> 58<sup>s</sup>. This, however, is negatived by two facts. If the first disturbance was felt at Carson City, the violent shock, which was many times stronger, should have been felt at a far greater distance, whereas Winnemucca and Eureka, about twice as far from the origin as Carson City, are the most distant points where the disturbance was noticed, and the intensity at these places was so much less than at Carson City, that we must suppose they all felt the same disturbance; it does not seem possible that Carson City could have felt the earlier and lighter shock and that the violent shock was not felt at far greater distances than Winnemucca and Eureka. Again, if Carson City felt the earlier shock at 5<sup>h</sup> 12<sup>m</sup> 25<sup>s</sup>, 27 seconds after its occurrence, the velocity of transmission would have been 291/27 or 10.8 km./sec. This is greater than can be admitted, for the velocity of transmission increases with the distance measured along the chord, and the velocity for points ten times as far from the origin as Carson City is only about 8.5 km./sec. We are obliged either to suppose that there is an error in the time report from Carson City, or that a light local shock occurred in its neighborhood a few seconds before the violent shock occurred on the coast. The latter could not have been felt at Carson City before 5<sup>h</sup> 13<sup>m</sup>, and as there is no record there of two disturbances the supposition of a local shock seems improbable. It is very unfortunate that we can not use the Carson City observations to determine the velocity of propagation of the earthquake disturbance.

---

<sup>1</sup> Professor Friend died in January, 1907.

## VICTORIA, BRITISH COLUMBIA.

Meteorological Office. R. F. Stupart, F. R. S. C, director; E. Baynes Reed, superintendent.

Lat.  $48^{\circ} 27' N.$ ; long.  $123^{\circ} 22' W.$ ; altitude, not much above sea-level; distance,  $10.41^{\circ}$  or 1,157 km.; chord, 1,155 km.; direction, N.  $20^{\circ} W.$

Foundation, solid rock.

Seismograms, sheet No. 1.

The instrument used was a Milne horizontal pendulum, east component; photographic registration.  $T_0$ , 15 seconds;  $V$ , 6.1;  $J$ , 330 meters; angular displacement, 1 mm. =  $0.76''$ ;  $M$ , 255 gm.;  $L$ , 15.6 cm.

East component: First preliminary tremors,  $14.2^m$ ; second preliminary tremors,  $14.7^m$ ; maximum,  $17.1^m$ ; amplitude, 17+ mm.

There seems to have been a reinforcement of the motion at  $15.2^m$ , and at  $16.1^m$  the motion was strong enough to join the records from opposite sides of the seismogram; that is, the amplitude of the pointer exceeded 17 mm.; this continued with slight interruptions for 11 minutes, and then diminished with many irregularities; If Victoria recorded only the violent shock, the velocity of propagation would have been  $1,155/104 = 11.1$  km./sec, which is far too great; we must therefore believe that the beginning of the record refers to the earlier and lighter motion that began at  $5^h 11^m 58^s$  at a point 25 km. further from Victoria. The velocity would then be  $1,181/134 = 8.8$  km./sec, which is a little but not much larger than might be expected. The beginning of the strong motion on the seismogram, coming a half minute after the beginning of the record, occurs too early for the long waves from the earlier disturbance, and too early even for the second preliminary tremors. It must represent the first preliminary tremors of the violent shock, whose velocity would then be  $1,155/134 = 8.6$  km./sec. We thus get two records of the velocity of the first preliminary tremors; which agree very well when we consider the difficulty of determining the exact point on the seismogram where the movements begin, and the further difficulty of reading the corresponding time as near as a tenth of a minute. The strong motion, beginning at  $16.1^m$ , would correspond in time to the arrival of the second preliminary tremors of the earlier shock, but as this shock was not felt in Sitka it does not seem possible that it could have made so great a record in Victoria, even tho the latter recorded especially the transverse vibrations and the former the longitudinal. The remainder of the record is complicated by the overlapping of vibrations coming apparently from different parts of the fault-plane.

## SITKA, ALASKA.

Magnetic Station of U. S. Coast and Geodetic Survey. O. H. Tittmann, superintendent; Dr. H. M. W. Edmonds, magnetic observer.

Lat.  $57^{\circ} 03' N.$ ; long.  $135^{\circ} 20' W.$ ; altitude, 15 meters; distance,  $20.72^{\circ}$  or 2,303 km.; chord, 2,291 km.; direction, N.  $19^{\circ} W.$

Foundation, directly on solid rock.

Seismograms, sheet No. 11.

The instrument was a Bosch-Omori horizontal pendulum, north component; mechanical registration on smoked paper.  $T_0$ , 14 seconds;  $V$ , 10;  $J$ , 490 meters;  $e$ , 1.0;  $r$ , 1.0 mm.;  $M$ , 10 kg.;  $L$ , 75cm.

	FIRST PRELIMINARY TREMORS.		SECOND PRELIMINARY TREMORS.		REGULAR WAVES.		MAX.				AMPLITUDE.
	<i>m.</i>	<i>«.</i>	<i>m.</i>	<i>s.</i>	<i>m.</i>	<i>«.</i>	<i>m.</i>	<i>s.</i>	<i>m.</i>	<i>».</i>	<i>mm.</i>
North component	17	02	21	06	22	32	23	30	to 30	20	65 +
Interval . .	4	34	8	38	10	04					

There were no regular time marks on the seismograms, but certain marks have been made artificially, which enable us to make fair estimates of the times.

The motion begins very gently at 17<sup>m</sup> 02<sup>s</sup>; at 17<sup>m</sup> 32<sup>s</sup> a stronger movement occurs, which dies down in a little over a minute; it is possible that this is the true beginning of the first preliminary tremors; at the beginning and soon after the end of this movement there were east-west jars which shook the recording drum and caused an overlapping of the record. The beginning of the second preliminary tremors is about 21<sup>m</sup> 06<sup>s</sup> with an amplitude of 11 mm. This continued with some irregularity until 22<sup>m</sup> 32<sup>s</sup>, when the marker went beyond the limits of the paper, i.e., with an amplitude greater than 65 mm. The strong motion lasted about 14.5 minutes to 13<sup>h</sup> 36<sup>m</sup>, and then the movement continued with small amplitude and occasional reinforcements until about 15<sup>h</sup> 17<sup>m</sup>. It is not unlikely that the times at Sitka are all about a half-minute too late; this correction would make them accord better with observations from other stations in drawing the hodographs.

The damping is entirely negligible; and the solid friction is not large. The period during the large motion is practically that of the pendulum, so that it is impossible to estimate the magnification, or the actual movement of the earth.

The question arises: Did Sitka, like Victoria, record the early slight shock or only the violent shock? If it recorded the early shock, the average velocity from the origin would have been  $2,316/304 = 7.63$  km./sec; but since this shock reached Victoria at 14.2<sup>m</sup>, it must have progressed from that neighborhood to Sitka at a rate of about  $(2,316 - 1,180)/170 = 6.7$  km./sec. We can not believe that the disturbance advanced for the first half of the distance to Sitka at a rate of 8.8 km./sec, and for the second half only at a rate of 6.7 km./sec. We are, therefore, obliged to believe that Sitka, which recorded the component at right angles to that recorded at Victoria, really recorded only the violent shock; the velocity for which then becomes  $2,291/274 = 8.36$  km./sec, which is about the velocity we should expect.

#### TACUBAYA, D. F., MEXICO.

Observatorio Astronomico Nacional. Señor F. Valle, director.  
 Lat. 19° 24' N.; long. 99° 12' W.; altitude, 2,280 meters; distance, 27.70° or 3,081 km.;  
 chord, 3,050 km.; direction, S. 54° E.  
 Foundation, alluvium.  
 Seismograms, sheet No. 9.

The instruments used were Bosch-Omori horizontal pendulums, two horizontal components; mechanical registration on smoked paper.

- (1) North component:  $T_0$ , 17.3 seconds;  $J$ , 1,120 meters;  $A_f$ , 10 kg.;  $L$ , 75 em.  
 (2) East component:  $T_0$ , 17.6 seconds;  $V$ , 15;  $I$ , 1,100 meters;  $M$ , 10 kg.;  $L$ , 75 em.

	FIRST PRELIMINARY TREMORS.	SECOND PRELIMINARY TREMORS.	REGULAR WAYES.	PRINCIPAL PAST.	MAX.	AKPUTIDX.	Praia@.
	m. s.	m. s.	TO. s.	m. t.	m. s.	mm.	
(1) North component	17 58	22 50	25 08	26 40	26 45	60 +	15-25
(2) East component	17 58	22 54	25 06	25 50	26	80 +	
Average . . .	17 58	22 52	25 37	26 45			
Interval . . .	5 30	10 24	13 09	13 37			

The second phase is much stronger on the east component than on the north component, which is due to synchronism of periods; and the long waves begin more definitely on the east component.

The periods during the strong motion approach those of the pendulums and therefore we can not estimate the earth's movement; the fact that the marker goes beyond the limits of the record very near the beginning of the strong motion shows, however, that the earth's displacement was large.

## CLEVELAND, OHIO.

St. Ignatius College Observatory. Rev. F. L. Odenbach, S. J., director.  
 Lat.  $41^{\circ} 29' N.$ ; long.  $81^{\circ} 42' W.$ ; altitude, 230 meters; distance,  $31.47^{\circ}$  or 3,498 km.;  
 chord, 3,456 km.; direction, N.  $71^{\circ} E.$   
 Foundation, stiff clay.  
 Seismograms, sheet No. 3.

The instrument used was a heavy pendulum, prevented from swinging by four carbon rods pressing against it in directions  $90^{\circ}$  apart. Electric currents pass thru the carbons and the pendulum and then thru carefully balanced solenoids, which carry pens marking on white paper. At the time of a shock the pressure of the pendulum against the carbons, and hence the currents, vary, and the marking pens are displaced, making a record. The preliminary tremors can not be made out; but the principal part begins about  $13^h 29.4^m$ .

## TORONTO, CANADA.

Meteorological Office. R. F. Stupart, F. R. S. C, director.  
 Lat.  $43^{\circ} 40' N.$ ; long.  $79^{\circ} 23' E.$ ; altitude, 107.5 meters; distance,  $32.93^{\circ}$  or 3,571 km.; chord, 3,610 km.; direction, N.  $66^{\circ} R$   
 Foundation, boulder clay, 32 meters above Lake Ontario.  
 Seismograms, sheet No. 1.

The instrument used was a Milne horizontal pendulum, east component; photographic registration.  $T_o$ , 14.8 seconds;  $V$ , 6.1;  $J$ , 330 meters;  $e$ , 1.051; angular displacement, 1 mm. = 0.66";  $M$ , 255 gm.;  $L$ , 15.6 cm.

	FIRST PRELIMINARY TREMORS.	SECOND PRELIMINARY TREMORS.	REGULAR WAVES.	MAX.	AMPLITUDE.
East component . . . . .	<i>min.</i> 19.3	<i>min.</i> 24.5	<i>min.</i> 27.9	<i>min.</i> 33.3	<i>mm.</i> 17 +
Interval . . . . .	6.8	12.0	15.4		

Beginning given as  $19.3^m$ ; intensified at  $24.5^m$ ; and again at  $27.6^m$ ; at  $32.0^m$  the records join from opposite sides, *i.e.*, the amplitude was greater than 17 mm. This continues with one interruption for 10 minutes. The motion dies down considerably, but at  $55.0^m$  the sides again join for 2 minutes with one small interruption. The remainder of the record is subsiding. The period during the strong motion can not be determined from the seismogram on account of the close time scale, but from records at other stations it could not be very different from that of the pendulum, and this accounts in part for the large amplitude.

## HONOLULU, HAWAIIAN ISLANDS.

Magnetic Observatory of U. S. Coast and Geodetic Survey. O. H. Tittmann, superintendent; S. A. Deel, magnetic observer.  
 Lat.  $21^{\circ} 19' N.$ ; long.  $158^{\circ} 04' W.$ ; distance,  $34.60^{\circ}$  or 3,846 km.; chord, 3,790 km.;  
 direction, S.  $71^{\circ} W.$   
 Foundation, directly on solid coral rock.  
 Seismograms, sheet No. 2.

The instrument used was a Milne horizontal pendulum, east component; photographic registration.  $T_o$ , 19 seconds;  $V$ , 6.1;  $J$ , 560 meters;  $M$ , 255 gm.;  $L$ , 15.6 cm.

	FIRST PRELIMINARY TREMORS.	SECOND PRELIMINARY TREMORS.	MAX.	AMPLITUDE.
East component . . .	<i>min.</i> 19.5	<i>min.</i> 24.4	<i>min.</i> 26.2 to 28.2	<i>mm.</i> 17 +
Interval . . . . .	7.0	11.9	28.9 to 32.1	17 +

The instrument was not perfectly still and the time of the beginning is difficult to determine. The time given is that of the observer in charge. There is a well-marked movement 0.6 minute later, which may mark the arrival of waves reflected once internally at the earth's surface. The time of arrival of the long waves is not definite. There are large vibrations at 26.6<sup>m</sup> and others at 29.1<sup>m</sup>; the latter fit the hodograph of the regular waves, but they are too uncertain and have not been used.

## OTTAWA, CANADA.

Astronomical Observatory. Dr. Otto J. Klotz, director.

Lat. 45° 24' N.; long. 75° 43' W.; altitude, 82 meters; distance, 35.37° or 3,932 km.; chord, 3,871 km.; direction, N. 62° E.

Foundation, boulder clay.

Seismograms, sheet No. 10.

The instruments used were Bosch-Omori horizontal pendulums, two horizontal components; photographic registration.

(1) North component:  $T_0$ , 5.71 seconds;  $V$ , 120;  $J$ , 970 meters;  $e$ , 1.50;  $r$ , 0.0 mm.;  $M$ , 200 gm.;  $L$ , 6.68 cm.

(2) East component:  $T_0$ , 7.06 seconds;  $V$ , 120;  $J$ , 1,500 meters;  $e$ , 1.76;  $r$ , 0.0 mm.;  $M$ , 200 gm.;  $L$ , 6.68 cm.

	FIRST PRELIMINARY TREMOBB.	SECOND PRELIMINARY TREMORS.	PRINCIPAL PART.
(1) North component . . .	<i>m.</i> 19 <i>a.</i> 25	<i>m.</i> 24 <i>a.</i> 50	<i>m.</i> 30 <i>a.</i> 40
(2) East component . . .	19   12	..   ..	31   20(?)
Average . . . . .	19   19	24   50	31.0
Interval . . . . .	6   51	12   22	18.5

The east component began 13 seconds before the north; this indicates that the longitudinal motion began before the transverse. The north earth-amplitude (one minute after the beginning) was 0.004 mm.; and the east earth-amplitude (0.5 minute after beginning) was 0.005 mm. These values are somewhat uncertain on account of the closeness of periods. The periods of the waves are not very different from that of the pendulums. On the north component the motion became so large for 10 minutes after 31.0<sup>m</sup> that it can not be followed; it then dies down to quiet at about 16<sup>h</sup> 30<sup>m</sup>. On the east component the records are superposed so that the phases can not be distinguished after the beginning.

## WASHINGTON, DISTRICT OF COLUMBIA.

U. S. Weather Bureau. Prof. Willis L. Moore, chief; Prof. C. F. Marvin in charge of seismographs.

Lat. 38° 54' N.; long. 77° 03' W.; altitude, 20.5 meters; distance, 35.44° or 3,939 km.; chord, 3,878 km.; direction, N. 74° E.

Foundation, firm clay and gravel; solid rock probably within 8 meters.

Seismograms, sheet No. 8.

The instrument used was a Bosch-Omori horizontal pendulum; east component; mechanical registration on smoked paper.  $T_0$ , 32 seconds,  $V$ , 10;  $J$ , 2,540 meters;  $e$ , 1.35;  $r$ , 0.56 mm.;  $M$ , 17.35 kg.;  $L$ , 75.2 cm.

	FIRST PRELIMINARY TREMORS.	SECOND PRELIMINARY TREMORS.	REGULAR WAVES.	PRINCIPAL PART.	MAX.	AMPLITUDE.
East component	<i>m.</i> <i>a.</i> 19 20	<i>m.</i> <i>s.</i> 25 00	<i>m.</i> <i>a.</i> 29 20	<i>min.</i> 30.5	<i>min.</i> 32 to 35	<i>mm.</i> 95
Interval	6 52	12 32	16 52	18.0		

Duration, 4.3 hours. Perhaps the long waves should begin a minute earlier. The very strong motion only lasted about 4.5 minutes. During the second preliminary tremors the period was about 25 seconds, and amplitude 95 mm., corresponding to an earth-amplitude of 0.4 mm. During the regular waves at 32.0<sup>m</sup> when the pointer went off the record, the period was about 30 seconds, practically that of the pendulum; so that we can not draw conclusions regarding the actual motion of the ground.

## CHELTENHAM, MARYLAND.

Magnetic Observatory of U. S. Coast and Geodetic Survey. O. H. Tittmann, superintendent; W. F. Wallis, magnetic observer.

Lat. 38° 44' N.; long. 76° 50.5' W.; altitude, 72 meters; distance, 35.64° or 3,962 km.; chord, 3,899 km.; direction, N. 74° E.

Foundation, sands and gravel.

Seismograms, sheet No. 8.

The instruments used were Bosch-Omori horizontal pendulums, two horizontal components; mechanical registration on smoked paper. The corrections to G. M. T. are negative for both components.

(1) North component:  $T_0$ , 20 seconds;  $V$ , 10;  $J$ , 1,000 meters;  $M$ , 10 kg.;  $L$ , 75 cm.

(2) East component:  $T_0$ , 25 seconds;  $V$ , 10;  $J$ , 1,560 meters;  $M$ , 10 kg.;  $L$ , 75 cm.

	FIRST PRELIMINARY TREMORS.	SECOND PRELIMINARY TREMORS.	REGULAR WAVES.	PRINCIPAL PART.	PERIOD.	AMPLITUDE.
(1) North component	<i>m.</i> <i>s.</i> 19 30	<i>m.</i> <i>s.</i> 25 01	<i>to.</i> <i>s.</i> 30 00	<i>min.</i> 32.3 to 36	<i>sec.</i> 13	<i>mm.</i> 40 +
(2) East component	19 16	25 09	30 32	32.8 to 39	9	35 +
Average	19 23	25 05	30 16	32.5		
Interval	6 55	12 37	17 48	20.0		

Duration, north, 2.7 hours; east, 3.1 hours. The time of the first preliminary tremors on north component is not very definite, but it is not later than 19<sup>h</sup> 30<sup>m</sup>. The longitudinal waves apparently arrived some seconds earlier than the transverse. This probably means that the longitudinal waves were first felt, and then the disturbance became more complex. The regular waves are a little earlier on the north than on the east component, as is also the strong motion.

The dying-out curves sent me to determine the damping and friction are too irregular to yield definite results, which is probably due to irregular friction; but if we neglect the damping and frictional terms, we find the magnifying power of the north component for waves of period 13 seconds (13<sup>h</sup> 34<sup>m</sup>) to be 17.3; and since the amplitude of the pendulum is 40 mm. that of the earth would be 2.3 mm.; with the same assumption, the magnifying power of the east component for waves of period 9 seconds (13<sup>h</sup> 36<sup>m</sup>) is 11; and the corresponding earth-amplitudes, 3.2 mm. But both of these values are too small, as the movements of the pendulums seem to have been limited by the stops. It is not unlikely that the total earth-amplitude at Cheltenham may have amounted to 5 mm.

## BALTIMORE, MARYLAND.

Johns Hopkins University. Prof. Harry Fielding Reid, in charge of seismographs.  
 Lat.  $39^{\circ} 18' N.$ ; long.  $76^{\circ} 37' W.$ ; altitude, 30 meters; distance,  $35.74^{\circ}$  or 3,973 km.;  
 chord, 3,909 km.; direction, N.  $73^{\circ} E.$

Foundation, clays and gravels, about 30 meters thick, resting on rock.

Seismograms, sheet No. 1.

The instrument used was a Milne horizontal pendulum; component, N.  $60^{\circ} W.$ ; photographic registration. TQ, 14 seconds;  $1^{\wedge}, 6.1$ ; J, 300 meters; e, 1.03; r, 0.0mm.; angular displacement, 1 mm. = 0.83"; M, 255 gm.; L, 15.6 cm.

	FIRST PRELIMINARY TREMORS.	SECOND PRELIMINARY TREMORS.	PRINCIPAL PART.	MAX.	AMPLITUDE.
N. $60^{\circ} W.$ component	<i>min.</i> 19.4	<i>min.</i> 25.2	<i>min.</i> 31.6	<i>min.</i> 31.8 to 39.1	<i>mm.</i> 17 +
Interval . . . . .	6.9	12.7	19.1		

If we assume that the wave period at Baltimore was the same as that at Cheltenham, namely, 13 seconds, we see that the large amplitude at this station is due to synchronism of periods of the waves and the pendulums.

## ALBANY, NEW YORK.

New York State Museum. Dr. John M. Clarke, State geologist.

Lat.  $42^{\circ} 39' N.$ ; long.  $73^{\circ} 45' W.$ ; altitude, 26 meters; distance,  $37.13^{\circ}$  or 4,128 km.;  
 chord, 4,056 km.; direction, N.  $67^{\circ} E.$

Foundation, heavy blue clay with interbedded sand and gravel.

Seismograms, sheet No. 8.

The instruments used were Bosch-Omori horizontal pendulums, two horizontal components; mechanical registration on smoked paper. Constants for both components:  $T_0$ , 30 seconds; V, 10;  $\lambda$ , 2,240 meters; M, 11.28 kg.; L, 85.5 cm.

	FIRST PRELIMINARY TREMORS.	SECOND PRELIMINARY TREMORS.	REGULAR WAVES.	PRINCIPAL PART.	MAX.	AMPLITUDE.
(1) North component	<i>m.</i> 8. 21 30	<i>m.</i> 8. 29 04	<i>m.</i> ». 33 00	<i>min.</i> 33.5 to 35.5	<i>m.</i> ». 34 30	<i>mm.</i> 32
(2) East component	21 30	28 00	32 30	34.0 to 42	34 40	22
Average . . . . .	21 30	28 32	32 45	33.7		
Interval . . . . .	9 02	16 04	20 17	21.2		

Duration, north, 2.1 hours; east, 2.7 hours. The times of the preliminary tremors are two or three minutes too late. The strong motion on the east component lasted about 9 minutes, on the north component only 2 minutes; but the greatest amplitude was shown by the latter. The strong motion was not regular nor long enough to estimate the amplitudes of the earth's motion.

## PORTO RICO (VIEQUES), WEST INDIES.

Magnetic Observatory of U. S. Coast and Geodetic Survey. O. H. Tittmann, superintendent; P. H. Dike, magnetic observer.

Lat.  $18^{\circ} 08' N.$ ; long.  $65^{\circ} 26' W.$ ; altitude, 40 meters; distance,  $53.45^{\circ}$  or 5,942 km.;  
 chord, 5,729 km.; direction, S.  $85^{\circ} E.$

Seismograms, sheet No. 8.



The instruments used were Bosch-Omori horizontal pendulums, two horizontal components; mechanical registration on smoked paper.

(1) North component:  $T_0$  20 seconds;  $V$ , 10;  $J$ , 1,000 meters;  $e$ , 1.066;  $r$ , 3.25 mm.;  $M$ , 11 kg.;  $L$ , 75 cm.

(2) East component:  $T_0$  21 seconds;  $V$ , 10;  $J$ , 1,100 meters;  $e$ , 1.0;  $r$ , 2.6 mm.;  $M$ , 11 kg.;  $L$ , 75 cm.

	FIRST PRELIMINARY TREMORS.		SECOND PRELIMINARY TREMORS.		REGULAR WAVES.	PRINCIPAL PART.	MAX.	AMPLITUDE.
	<i>m.</i>	<i>a.</i>	<i>m.</i>	<i>a.</i>	<i>min.</i>	<i>min.</i>	<i>m.</i>	<i>s.</i>
(1) North component	21	45	30	24	40?	43 to 50?	48	50
(2) East component	21	54	29	50	39?	47.5 to 54.5?	50	0
Average . . . .	21	50	30	07	39.5?			
Interval . . . .	9	22	17	39	27.0?			

Duration, north, 2 hours; east, 2.5 hours. The periods of the waves coincide with periods of the pendulums and the strong motion lasted too short a time to enable an estimate of the earth's motion to be made. There seems to have been a certain amount of separation of the north and east components of the waves, as the strong motion of each occurs when that of the other is much reduced. The regular waves do not appear very definitely.

#### TRINIDAD, BRITISH WEST INDIES.<sup>1</sup>

St. Clair Experiment Station of the Botanical Gardens. J. H. Hart, F. L. S., superintendent.

Lat. 10° 40' N.; long. 61° 30' W.; altitude, 20.5 meters; distance, 60.94° or 6,774 km.; chord, 6,460 km.; direction, S. 80° E.

Foundation, 2 meters of concrete laid on sands and clays.

The instrument used was a Milne horizontal pendulum, east component; photographic registration.  $T_0$ , 18 seconds;  $V$ , 6.1;  $J$ , 490 meters; angular displacement, 1mm. = 0.5";  $M$ , 255 gm.;  $L$ , 15.6 cm.

Preliminary tremors, 11<sup>m</sup>; regular waves, 42<sup>m</sup>; maximum, 53<sup>m</sup>; amplitude, 10<sup>m</sup>. Interval for regular waves, 29.5 minutes.

The record of the commencement is evidently erroneous. The time of arrival of the regular waves at 42<sup>m</sup> may be fairly correct. Duration 3.2 hours.

#### APIA, SAMOA.<sup>1</sup>

Observatorium der Kgl. Gesellschaft der Wissenschaften in Göttingen. Dr. F. Linke, director.

Lat. 13° 48' S.; long. 171° 46' W.; distance, 69.20° or 7,694 km.; chord, 7,235 km.; direction, S. 52° W.

The instrument used was a Wiechert inverted pendulum (1,000 kg.), two horizontal components; mechanical registration on smoked paper.

First preliminary tremors, 23<sup>m</sup> 22<sup>s</sup>; interval, 10<sup>m</sup> 54<sup>s</sup>.

Second preliminary tremors, 32<sup>m</sup> 24<sup>s</sup>; interval, 19<sup>m</sup> 56<sup>s</sup>.

<sup>1</sup> The data were obtained from Circular 14 of the Seismological Committee of the B. A. A. S.

<sup>2</sup> Information obtained from Wiechert and Zoeppritz, "Ueber Erdbebenwellen"; Nach. Kgl. Gesell. Wissen. Göttingen, Math.-Phys. Kl., 1907.

MIZUSAWA, JAPAN.<sup>1</sup>

Meteorological Observatory.

Lat. 39° 08' N.; long. 141° 07' E.; distance, 70.46° or 7,834 km.; chord, 7,349 km.; direction, N. 55° W.

The instrument used was an Omori horizontal pendulum; mechanical registration on smoked paper.

First preliminary tremors, 24<sup>m</sup> 07<sup>s</sup>; interval, 11<sup>m</sup> 39<sup>s</sup>.

Second preliminary tremors, 33<sup>m</sup> 14<sup>s</sup>; interval, 20<sup>m</sup> 46<sup>s</sup>.

Apia has a Wiechert pendulum which magnifies more than the Omori at Mizusawa and therefore probably showed the movement more promptly.

## PONTA DELGADA, AZORES.

Serviço Meteorológico dos Açores. Major F. A. Chaves, director.

Lat. 37° 44' N.; long. 25° 41' W.; altitude, 16 meters; distance, 72.53° or 8,064 km.; chord, 7,536 km.; direction, N. 55° E.

Foundation, basaltic rock in a volcanic region.

Seismograms, sheet No. 1.

The instrument used was a Milne horizontal pendulum, east component; photographic registration.  $V$ , 6.1; angular displacement, 1 mm. = 0.49";  $M$ , 255 gm.;  $L$ , 15.6 cm.

	FIRST PRELIMINARY TREMORS.	PRINCIPAL PART.	MAX.	AMPLITUDE.
East component . .	<i>min.</i> 23.6	<i>min.</i> 50.5?	<i>min.</i> 54.6	<i>mm.</i> 7.3
Interval . . .	11.1	38.0?		

Duration, 3.5 hours. The second preliminary tremors are not distinguishable. There is a curious difference between the seismograms of Ponta Delgada and those of Paisley and Edinburgh, at practically the same distance from the origin. In the former, the first preliminary tremors are stronger and the beginning of the second preliminary tremors are not clearly differentiated; in the two latter, the first preliminary tremors are very feeble but the second preliminary tremors begin sharply.

## PAISLEY, SCOTLAND.

Coats Observatory. David Crilley, director.

Lat. 55° 51' N.; long. 4° 26' W.; altitude, 32 meters; distance, 72.54° or 8,065 km.; chord, 7,537 km.; direction, N. 31° E.

Foundation, boulder clay.

Seismograms, sheet No. 1.

The instrument used was a Milne horizontal pendulum, east component; photographic registration.  $T_0$ , 17 seconds;  $V$ , 6.1;  $L$ , 440 meters; angular displacement, 1 mm. = 0.55";  $M$ , 255 gm.;  $L$ , 15.6 cm.

	FIRST PRELIMINARY TREMORS.	SECOND* PRELIMINARY TREMORS.	REGULAR WAVES.	PRINCIPAL PART.	MAX.	AMPLITUDE.
East component . .	<i>min.</i> 23.2	<i>min.</i> 33.3	<i>min.</i> 47.4	<i>min.</i> 51.0 to 0.0	<i>min.</i> 54 to 57	<i>mm.</i> 17 +
Interval . . .	1(K7)	20.8	34.9	38.5		

Duration, 4.1 hours. The period of the long waves was from 25 to 30 seconds.

<sup>1</sup> Information obtained from "Preliminary Note on the Seismographic Observations of the San Francisco Earthquake," by F. Omori, Bull. Imperial Earthquake Investigation Commission, vol.1, No. 1.

BERGEN, NORWAY.<sup>1</sup>

Seismical Station of the Museum. Prof. Dr. Carl F. Kolderup, director.

Lat. 60° 24' N.; long. 5° 18' E.; altitude, 20 meters; distance, 72.79° or 8,092 km.; chord, 7,560 km.; direction, N. 24° E.

The instruments used were Bosch-Omori horizontal pendulums, two components; mechanical registration on smoked paper; *V*, 15.

	FIRST PRELIMINARY TREMORS.		SECOND PRELIMINARY TREMORS.		PRINCIPAL PART.		MAX.	PERIOD.	AMPLITUDE.
	<i>in.</i>	<i>s.</i>	<i>m.</i>	<i>a.</i>	<i>m.</i>	<i>s.</i>	<i>m.</i>	<i>s.</i>	<i>mm.</i>
(1) North component	22	46	32	09	..	..	54	45	5.0
(2) East component.	22	56	32	20	51	44	55	06	50.0
Average . . .	22	51	32	15	51	44	54	55	
Interval . . .	10	23	19	47	39	16	42	27	

The great difference between the maximum amplitudes is probably due to differences in the periods of the two pendulums.

## EDINBURGH, SCOTLAND.

Royal Observatory. Thomas Heath, director.

Lat. 55° 55.5' N.; long. 3° 11' W.; altitude, 131.5 meters; distance, 72.99° or 8,115 km.; chord, 7,578 km.; direction, N. 31° E.

Foundation, Devonian lava.

Seismograms, sheet No. 1.

The instrument used was a Milne horizontal pendulum, east component.  $T_0$ , 17 seconds; *V*, 6.1; *J*, 440 meters; *e*, 1.11; angular displacement, 1 mm. = 0.54"; *M*, 255 gm.; *L*, 15.6 cm.

	FIRST PRELIMINARY TREMORS.	SECOND PRELIMINARY TREMORS.	REGULAR WAVES.	PRINCIPAL PART.	MAX.	AMPLITUDE.
	<i>min.</i>	<i>min.</i>	<i>min.</i>	<i>min.</i>	<i>min.</i>	<i>mm.</i>
East component . .	23.5	33.0	48.0	52.0 to 05.6	54.2 to 56.7	17 +
Interval . . .	11.0	20.5	35.5	39.5		

Duration, 3.7 hours.

## TOKYO, JAPAN.

Tokyo Imperial University. Prof. F. Omori, D. Sc, director.

Lat. 35° 42.5' N.; long. 139° 46' E.; distance, 73.92° or 8,217 km.; chord, 7,660 km.; direction, N. 57° W.

Seismograms, sheet No. 11.

The instrument used was an Omori horizontal pendulum, east component; mechanical registration on smoked paper.  $T_0$ , 41.5 seconds; *T*, 30; *J*, 1,290 meters; *M*, 16.5 kg.; *L*, 75 cm.

	(a) FIRST PRELIMINARY TREMORS.	(b) SECOND PRELIMINARY TREMORS.	REGULAR WAVES.	(d) PRINCIPAL PART.	MAX.	AMPLITUDE.
	<i>rr.</i> <i>a.</i>	<i>m.</i> <i>s.</i>	<i>w.</i> <i>s.</i>	<i>m.</i> <i>a.</i>	<i>to.</i> <i>s.</i> <i>m.</i> <i>s.</i>	<i>mm.</i>
East component	24 35	34 24	46 20	50 15	46 45 to 48 10	93 +
Interval . . .	12 07	21 56	33 52	37 47		

<sup>1</sup> The information was obtained from "Registrierungen an der seismischen Station in Bergen in Jahre 1906," by Carl F. Kolderup. Bergens Museum Aarbog, 1907, 2 Hefte. A mechanical reproduction of the seismogram there is given.

At 15<sup>h</sup> 31<sup>m</sup>, (f), vibrations propagated along major arc, according to Professor Omori. The large amplitudes shown, both at the beginning of the second preliminary tremors and in the long waves are due to approximate synchronism of periods of the waves and the pendulum.

## BIDSTOFr, ENGLAND.

Liverpool Observatory. W. E. Plummer, director.

Lat. 53° 24' N.; long. 3° 04' W.; altitude, 54 meters; distance, 74.81° or 8,317 km.; chord, 7,739 km.; direction, N. 33° E.

Foundation, sandstone.

Seismograms, sheet No. 1.

The instrument used was a Milne horizontal pendulum, east component; photographic registration.  $T_0$ , 18.7 seconds;  $V$ , 6.1;  $\lambda$ , 530 meters;  $e$ , 1.057;  $M$ , 255 gm.;  $L$ , 15.6 cm.

	FIRST PRELIMINARY TREMORS.	SECOND PRELIMINARY TREMORS.	REGULAR WAVES.	PRINCIPAL PART.	MAX.	AMPLITUDE.
East component Interval	<i>min.</i> 24.3 11.8	<i>min.</i> 34.0 21.5	<i>min.</i> 45.2 35.7	<i>min.</i> 51.6 39.1	<i>min.</i> 54.3, 56.3 to 58.2	<i>THVU</i> 17+

Duration, 4.1 hours. The regular waves can be recognized by their greater period, which amounts to 24 seconds against 19 seconds during the principal part; this becomes still shorter during the strongest part of the disturbance. A comparison with the seismograms of Edinburgh, Paisley, and Kew also help to identify this phase, tho there is not so marked a change in amplitude at its beginning as in the other seismograms mentioned.

## UPSALA, SWEDEN.

Meteorological Observatory of the University. Prof. Dr. H. H. Hildebrandsson, director.

Lat. 59° 51.5' N.; long. 17° 37.5' E.; altitude, 16 meters; distance, 76.80° or 8,538 km.; chord, 7,914 km.; direction, N. 19° E.

Seismograms, sheet No. 9.

The instrument used was a Wiechert inverted pendulum, two horizontal components; mechanical registration on smoked paper.

(1) North component:  $T_{01}$  6.8 seconds;  $V$ , 230;  $J$ , 2,650 meters;  $\epsilon$  3;  $M$ , 1,000 kg.;  $Z$ , 11.5 meters;  $L$ , 1 meter.

(2) East component:  $T_0$ , 5.3 seconds;  $V$ , 270;  $\lambda$ , 1,900 meters;  $e$ , 3;  $M$ , 1,000 kg.;  $U$ , 11.5 meters;  $L$ , 1 meter.

	FIRST PRELIMINARY TREMORS.	SECOND PRELIMINARY TREMORS.	REGULAR WAVES.	PRINCIPAL PART.	MAX.	AMPLITUDE.	PERIOD.
	<i>m. B.</i>	<i>m. «.</i>	<i>m. «.</i>	<i>m. a.</i>	<i>m. a.</i>		<i>sec.</i>
(1) North component	24 51	34 43	50 20	54 05 j	55 00 59 15 02 45	46 50 57	15
(2) East component	24 51	34 45	.. ..	52 00 to 55	54 00	15	
Average	24 51	34 44	50 20	53 02?			
Interval	12 23	22 16	37 52	40 34?			

Duration, 3 hours. The first and second preliminary tremors are especially well defined. The amplitudes of the long waves are about equal on the north and on the east components; what appears to be the principal part on the east corresponds to dying down of regular waves on north. It is curious that the strongest motion of east occurs when

north is weak, and the first strong maximum, at 55<sup>m</sup> of north, is at the weakest part of east. The other north maxima do not correspond to any reënforcement of the east component. The largest earth-amplitude occurred between 13<sup>h</sup> 50<sup>m</sup> and 52<sup>m</sup> and amounted, on the north component, to 3.6 mm.; on the east component, to 3.76 mm. At the maximum displacement of the north needle (14<sup>h</sup> 02<sup>m</sup> 45<sup>s</sup>) the earth-amplitude was only 1.2 mm. and at the maximum displacement of the east needle (13<sup>h</sup> 54<sup>m</sup>) the earth-amplitude was 1.9 mm.; a half minute earlier the north earth-amplitude was 2.8 mm.

#### SHIDE, ISLE OF WIGHT, ENGLAND.

Prof. John Milne, F. R. S., director.

Lat. 50° 41' N.; long. 1° 17' W.; altitude, 15 meters; distance, 77.08° or 8,569 km.; chord, 7,938 km.; direction, N. 34° E.

Foundation, disintegrated chalk over solid chalk.

The instruments used were:

(1) Milne horizontal pendulum, east component. Time scale, 1 mm. to 1 minute.  $T_0$ , 20 seconds;  $V$ , 6.1;  $J$ , 600 meters;  $M$ , 255 gm.; angular displacement, 1 mm. = 0.36";  $L$ , 15.6 cm.

(2) Milne Horizontal Pendulum, east component; time scale, 4.25 mm. to 1 minute. Seismograms, sheet No. 12.  $V$ , 6.1;  $M$ , 255 gm.;  $L$ , 15.6 cm.

Heavy horizontal pendulums, supported by an iron post more than 2 meters high. Seismograms, sheet No. 7.

(3) North component:  $V$ , 25.4;  $e$ , 1.24;  $r$ , 0.2 mm.;  $M$ , 45 kg.;  $L$ , 1.030 meters.

(4) East component:  $V$ , 8.3;  $e$ , 1.51;  $r$ , 0.0;  $M$ , 45 kg.;  $L$ , 1.030 meters.

	FIRST PRELIMINARY TREMORS.	SECOND PRELIMINARY TREMORS.	REGULAR WAVES.	PRINCIPAL PART.	MAX.	AMPLITUDE.
	<i>mm.</i>	<i>min.</i>	<i>min.</i>	<i>min.</i>	<i>min.</i>	<i>mm.</i>
(1) East component	23.7	...	...	...	58.2	17 +
(2) East component	24.1	34.2	49.7	...	57.1	16
(3) North component	25.0	...	51.4	56.6	58.0 to 01.5	70 +
(4) East component	...	...	50.7	...	54	17 +
Average . . .	<i>m.</i> 8. 24 16	<i>m.</i> <i>a.</i> 34 12	<i>m.</i> <i>a.</i> 50 36			
Interval . . .	11 48	21 44	38 08			

Duration (1) 4.4 hours; (2) 4.8 hours. The large amplitudes are probably due to coincidence of periods; they occur at different times for the different pendulums.

#### OSAKA, JAPAN.

Meteorological Observatory. N. Shimono, director.

Lat. 34° 42' N.; long. 135° 31' E.; distance, 77.30° or 8,594 km.; chord, 7,957 km.; direction, N. 56° W.

Seismograms, sheet No. 15.

The instrument used was an Omori horizontal pendulum, east component; mechanical registration on smoked paper.  $T_0$ , 27 seconds;  $V$ , 20;  $J$ , 3,600 meters.

	(a) FIRST PRELIMINARY TREMORS.	(6) SECOND PRELIMINARY TREMORS.	(d) REGULAR WAVES.	MAX.	AMPLITUDE	PERIOD.
	<i>m.</i> <i>a.</i>	<i>m.</i> <i>s.</i>	<i>m.</i> «.	<i>m.</i> <i>a.</i>	<i>mm.</i>	<i>sec.</i>
East component .	24 24	34 13	47 56 j	50 19	44	25
Interval . . .	11 56	21 45	35 28	50 03	31	

Duration, 3.1 hours. The period during the strong motion is closely that of the pendulum and in the absence of strong damping and exact knowledge of the damping ratio, the movement of the earth can not be estimated. The letters on the seismogram refer to the following times: *a*, 13<sup>h</sup> 24<sup>m</sup> 24<sup>s</sup>; *b*, 34<sup>m</sup> 13<sup>s</sup>; *c*, 42<sup>ra</sup> 26<sup>s</sup>; *d*, 47<sup>m</sup> 56<sup>s</sup>; *e*, 53<sup>m</sup> 51<sup>s</sup>; *f*, 14<sup>h</sup> 10<sup>m</sup> 22<sup>s</sup>; *g*, 25<sup>m</sup> 43<sup>s</sup>; *h*, 15<sup>h</sup> 01<sup>m</sup> 46<sup>a</sup>; *i*, 40<sup>m</sup> 11<sup>s</sup>; *j*, 16<sup>h</sup> 33<sup>m</sup> 08<sup>s</sup>.

## KOBE, JAPAN.

Meteorological Observatory. C. Nakagawa, director.

Lat. 34° 41' N.; long. 136° 10' E.; altitude, 53.3 meters; distance, 77.54° or 8,619 km.; chord, 7,976 km.; direction, N. 55° W.

Foundation, Paleozoic rocks.

Seismograms, sheet No. 5.

The instrument used was an Omori horizontal pendulum, north component; mechanical registration on smoked paper.  $T_0$ , 35 seconds;  $V$ , 10;  $\lambda$ , 3,000 meters;  $M$ , 5 kg.;  $L$ , 75 cm.

	(a) FIRST PRELIMINARY TREMORS.	(b) SECOND PRELIMINARY TREMORS.	REGULAR WAVES.	MAX.	AMPLITUDE.	PERIOD.
North component . . .	<i>m.</i> 8. 24 23	<i>m.</i> <i>a.</i> 34 19	<i>m.</i> <i>s.</i> 50 20	<i>m.</i> <i>a.</i> 52 56	<i>mm.</i> 15	<i>sec.</i> 23
Interval . . .	11 55	21 51	37 52			

Duration, 3 hours. Altho the long waves appear quite definitely to begin at (c), the time seems somewhat late. There are two well-marked but separated waves in this part of the motion with a period of 31 seconds and a very large amplitude, possibly in part due to harmony of periods. The amplitude of the earth during the principal part can not be determined as the motion lasted only a short time and the damping is small.

The letters on the seismogram refer to the following times: *a*, 13<sup>h</sup> 24<sup>m</sup> 23<sup>s</sup>; *b*, 34<sup>m</sup> 19<sup>s</sup>; *c*, 45<sup>m</sup> 31<sup>s</sup>; *d*, 53<sup>m</sup> 39<sup>s</sup>; *e*, 59<sup>m</sup> 55<sup>s</sup>; *f*, 14<sup>h</sup> 06<sup>m</sup> 06<sup>s</sup>; *g*, 12<sup>m</sup> 32<sup>s</sup>; *h*, 22<sup>m</sup> 29<sup>s</sup>; *i*, 57<sup>m</sup> 35<sup>s</sup>; *j*, 16<sup>h</sup> 26<sup>m</sup> 13<sup>s</sup>.

## KEW, ENGLAND.

National Physical Laboratory. Dr. Charles Chree, in charge of seismograph.

Lat. 51° 28' N.; long. 0° 19' W.; altitude, 6 meters; distance, 77.63° or 8,630 km.; chord, 7,986 km.; direction, N. 32° E.

Foundation, deep alluvial gravel; Mesozoic limestone 1,150 feet below the surface.

Seismograms, sheet No. 1.

The instrument used was a Milne horizontal pendulum, east component; photographic registration.  $T_0$ , 18 to 19 seconds;  $V$ , 6.1;  $J$ , 520 meters;  $e$ , 1.114;  $r$ , 0.0 mm.; angular displacement, 1 mm. = 0.55";  $M$ , 255 gm.;  $L$ , 15.6 cm.

	FIRST PRELIMINARY TREMORS.	SECOND PRELIMINARY TREMORS.	REGULAR WAVES.	MAX.	AMPLITUDE
East component . . .	<i>min.</i> 25.7	<i>min.</i> 34.0	<i>min.</i> 50.0	<i>min.</i> 57.0 to 02.0	<i>mm.</i> 17+
Interval . . .	13.2	21.5	37.5		

Duration, 3.8 hours. The time of the first preliminary tremors has not been used in the determination of velocity of propagation; it is fully a minute later than at all other stations which do not differ considerably from Kew in distance from the focus; and the beginning of the movement on the seismogram is too indefinite to permit a satisfactory determination of its time.

**HAMBURG, GERMANY.**

Hauptstation für Erdbebenforschung. Dr. R. Schiitt, director.

Lat. 53° 34' N.; long. 9° 59' E.; altitude, 16.2 meters; distance, 79.74° or 8,866 km.;  
chord, 8,167 km.; direction, N. 26° E.

The instruments used were Rebeur-Paschwitz horizontal pendulums, modified by Dr. Hecker, two components; photographic registration.

	FIRST PRELIMINARY TREMORS.		SECOND PRELIMINARY TREMORS.		REGULAR WAVES.		PRINCIPAL PART.	
	<i>m.</i>	<i>s.</i>	<i>m.</i>	«	<i>m.</i>	«	<i>m.</i>	«
North component . . .	..	..	34	42	..	..	<b>51</b>	<b>57</b>
East component . . .	<b>24</b>	<b>32</b>	34	57	44	32	<b>51</b>	<b>34</b>
Average . . .	<b>24</b>	<b>32</b>	34	50	44	32	<b>51</b>	<b>45</b>
Interval . . .	<b>12</b>	<b>04</b>	22	22	32	04	<b>39</b>	<b>17</b>

**UCCLE, BELGIUM.**

Observatoire Royale de Belgique. M. G. Lecoite, director.

Lat. 50° 48' N.; long. 4° 22' E.; altitude, 100 meters; distance, 79.80° or 8,872 km.;  
chord, 8,173 km.; direction, N. 31° E.

Foundation, coarse Tertiary limestone.

Seismograms, sheet No. 2 a.

The instrument used was an Ehlert triple pendulum, photographic registration.

(1) N. 60° E. component:  $T_0$ , 11.25 seconds;  $J$ , 160;  $J$ , 5,100 meters;  $e$ , 1.003;  $r$ , 0.0 mm.;  $M$ , 185 gm.;  $L$ , 10.08 cm.

(2) N. 60° W. component:  $T_0$ , 10.53 seconds;  $J$ , 160;  $J$ , 4,400 meters;  $e$ , 1.004;  $r$ , 6.0 mm.;  $M$ , 185 gm.;  $L$ , 10.08 cm.

(3) North component:  $T_0$ , 11.15 seconds;  $J$ , 160;  $J$ , 5,100 meters;  $e$ , 1.004;  $r$ , 0.0 mm.;  $M$ , 185 gm.;  $L$ , 10.08 cm.

	FIRST PRELIMINARY TREMORS.		REGULAR WAVES.	
	<i>m.</i>	<i>s.</i>	<i>m.</i>	«
(1) N. 60° E. component . . .	24	27	34	57
(2) N. 60° W. component . . .	24	27	34	57
(3) North component . . .	24	27	34	57
Average . . .	24	27	34	57
Interval . . .	11	59	22	29

All three pendulums suffered permanent displacements during the disturbance.

**JURJEW, RUSSIA.**

Astronomical Observatory of the University. Prof. Dr. G. Lewitsky, director; Dr. A. Orloff, assistant.

Lat. 58° 23' N.; long. 26° 43' E.; altitude, 48.5 meters; distance, 80.27° or 8,924 km.; chord, 8,212 km.; direction, N. 16° E.

Foundation, fine sand.

Seismograms, sheet No. 10.

The instruments used were Zöllner-Repsold horizontal pendulums, two components; photographic registration.

(1) North component:  $T_0$ , 31.53 seconds;  $J$ , 64.5;  $J$ , 15,000 meters;  $e$ , 1.004;  $r$ , 0.0 mm.;  $M$ , 50 gm.;  $L$ , 13.3 cm.

(2) East component:  $T_0$ , 28.22 seconds; 7,64.9;  $J$ , 13,000 meters;  $e$ , 1.005;  $r$ , 0.0 mm.;  $M$ , 50 gm.;  $L$ , 13.3 cm.

	FIRST PRELIMINARY TREMORS.		SECOND PRELIMINARY TREMORS.	
	to.	8.	m.	a.
(1) North component . . .	24	45	34	43
(2) East component . . .	24	41	34	49
Average . . . . .	24	43	34	46
Interval . . . . .	12	15	22	18

The seismograms are carefully drawn from the original, parts of which were so faint, on account of the rapid movement, that they could not be reproduced. (The correction to G. M. T. should be +43 seconds and not —43 seconds, as marked on the seismograms.) The north component begins in the middle of the sheet at the bottom of the seismogram; it had an amplitude of 15 mm. when the sheet was put on. This movement gradually died down, but the pendulum was not perfectly still when the earthquake arrived 3<sup>h</sup> 10<sup>m</sup> later. The first preliminary tremors have a small amplitude, about 1 mm., and a period the same as the period of the pendulum, showing an extremely small disturbance. The second preliminary tremors have an increasing amplitude from about 10 mm. to 20 mm.; at 13<sup>h</sup> 50<sup>m</sup> 45<sup>s</sup> the motion becomes so large and the photographic record so faint that it can not be copied; a few turning points are shown in the lower part of the plate; this continues for the rest of this line. The record is again picked up at the beginning of the next line at about 14<sup>h</sup>. The center of the record is shown by the single line on the left of the plate. The movement gradually dies down, but still has an amplitude of 20 mm. two hours later. The east component begins in the middle of the sheet; it has small oscillations which entirely die out before the preliminary tremors arrive. The first preliminary tremors and second preliminary tremors begin at the same time as those of the north component, but they have larger amplitudes, the first attaining an amplitude of 7 mm.; and the second, beginning with nearly 50 mm., attain 120 mm. by 13<sup>h</sup> 48<sup>m</sup>, and a few minutes later (13<sup>h</sup> 53<sup>m</sup> 45<sup>s</sup>) are lost. They are picked up again 8 minutes later, and about 14<sup>h</sup> 25<sup>m</sup> drop to an amplitude of about 40 mm.; they then gradually die out more irregularly than the other component. The very large amplitudes are due to synchronism of the periods of the waves and the pendulums.

#### IRKUTSK, SIBERIA.

Meteorological and Magnetic Observatory. M. A. Voznesenskij, director.

Lat. 52° 16' N.; long. 57° 14' E.; altitude, 470 meters; distance, 80.82° or 8,986 km.; chord, 8,259 km.; direction, N. 27° W.

Foundation, hard Jurassic clay.

The instruments used were:

Repsold-Zöllner horizontal pendulums, two components; photographic registration. Seismograms, sheet No. 2 a.

(1) North component:  $T_0$  35 seconds;  $V$ , 57.5;  $J$ , 17,500 meters; angular displacement, 1 mm, = 0.011";  $M$ , 30 gm.;  $L$ , 14 cm.

(2) East component:  $T_0$  25.5 seconds;  $V$ , 57.5;  $J$ , 9,300 meters; angular displacement, 1 mm, = 0.021";  $M$ , 30 gm.;  $L$ , 14 cm.

Bosch-Omori horizontal pendulums, two components; mechanical registration on smoked paper. Seismograms, sheet No. 13.

(3) North and (4) East components:  $T_0$  24 seconds;  $V$ , 10 (?);  $J$ , 1,430 meters (?);  $M$ , 11kg. (?);  $L$ , 75 cm. (?).



(5) Milne horizontal pendulum, east component, photographic registration. Seismograms, sheet No. 2.  $T_o$ , 20.5 seconds;  $V$ , 6.1;  $\lambda$ , 700 meters;  $M$ , 255 gm.;  $L$ , 15.6 cm.

	FIRST PRELIMINARY TREMORS.	SECOND PRELIMINARY TREMORS.	REGULAR WAVES.	MAX.	AMPLITUDE.	PERIOD.
	<i>min.</i>	<i>min.</i>	<i>min.</i>	<i>min.</i>	<i>mm.</i>	<i>sec.</i>
(1) North component .	24.6	34.3	...	54.6	165	24
(2) East component .	24.7	34.4	...	58.7	87.6	
(3) North component .	24.7	35.0	...	02.7	4.0	
(4) East component .	24.6	34.5	...	01.0	6.0	
(5) East component .	24.4	34.3	51.3	05.3	17+	
Average . . . . .	<i>m.</i> <i>s.</i> 24 36	<i>m.</i> <i>s.</i> 34 50	51.3			
Interval . . . . .	12 08	22 22	38.8			

Duration, (1) and (2), 6.5 hours; (3) 2.5; (4) 2.7; (5) 4.6.

On the Zöllner-Repsold records there is no clear evidence of long waves. The strong motion seems to have been stronger and to have lasted longer on the east component; it also began nearly two minutes earlier; but the north component shows a marked movement between 16<sup>h</sup> and 18<sup>h</sup> which is lacking in the east movement.

It is interesting to compare the records from the similar instruments at Jurjew and Irkutsk, which are practically the same distance from the centrum. We find certain differences; at Jurjew the north component is apparently the stronger and holds its strong motion longer, but comes to rest sooner than the east component; after about 15<sup>h</sup> it seems to be dying down with very slight irregularities; whereas the east component experiences distinct disturbances up to 17<sup>h</sup> 30<sup>m</sup>. We could give almost the same description of the movement at Irkutsk if we interchanged components. This is curious, as the disturbance approaches the two stations in directions making about the same angle with the meridian. It is unfortunate that the instruments have so little damping that their proper motions persist for a long time and interfere with a better interpretation of the seismograms. For instance, it is impossible to say whether the prolonged strong motion of the north component at Jurjew is due to a continued strong disturbance or to the proper motion of the pendulum. The east component may have felt just as strong and long a disturbance but its large displacement may have been checked by it. We do not find this difference between the components of the strongly damped pendulum at Gottingen, which is but slightly further from the centrum.

The periods of the movement at Irkutsk are decidedly larger than at Jurjew; at the latter, during the first and second preliminary tremors the periods are about 30 seconds, very near the natural periods of the pendulums; at Irkutsk they are about 37 seconds and 50 seconds for the east and north components, respectively, in comparison with the natural periods of the pendulums of 25 and 35 seconds. During the large motion the east component did not record, and the north component is too irregular to determine a period, but both indicate comparatively large displacements of the ground.

The maximum displacements of the Bosch-Omori pendulums at Irkutsk seem entirely due to synchronism of periods and indicate a comparatively small earth amplitude, just the opposite of the indications of the Repsold-Zöllner pendulums. The beginning of the long waves is not apparent on the Zöllner instruments unless we take it at the beginning of the strong motion, but appears pretty well on the Bosch-Omori records, and the period is about 1 minute.

The times of arrival at Jurjew and Irkutsk are practically the same, indicating uniform velocities along the two paths followed.

## POTSDAM, GERMANY.

Kgl. Preussisches Geodätisches Institut. Prof. Dr. O. Hecker, in charge of seismographs.

Lat.  $52^{\circ} 53' N.$ ; long.  $13^{\circ} 04' E.$ ; altitude, 90 meters; distance,  $81.35^{\circ}$  or 9,042 km.; chord, 8,303 km.; direction, N.  $25^{\circ} E.$

Foundation, sand.

The instruments used were:

Rebur-Paschwitz pendulums, photographic registration. Seismograms, sheet No. 4.

(1) North and (2) East components:  $T_o$ , 18 seconds;  $\gamma$ , 36;  $\lambda$ , 2,900 meters;  $e$ , 2.5;  $M$ , 70 gm.;  $L$ , 9 cm. (?).

Wiechert inverted pendulum, two components; mechanical registration on smoked paper. Seismograms, sheet No. 5.

(3) North component:  $T_o$ , 14 seconds;  $V$ , 133;  $J$ , 6,500 meters;  $e$ , 5;  $M$ , 1,000 kg.;  $U$ , 49 meters.

(4) East component;  $T_o$ , 14 seconds;  $V$ , 130;  $\lambda$ , 6,350 meters;  $e$ , 5;  $M$ , 1,000 kg.;  $L'$ , 49 meters.

	FIRST PRELIMINARY TREMORS.		SECOND PRELIMINARY TREMORS.	REGULAR WAVES.	PRINCIPAL PART.	MAX.	AMPLITUDE.	PERIOD.
	<i>m.</i>	<i>s.</i>	min.	<i>min.</i>	<i>m.</i>	<i>a.</i>	<i>mm.</i>	<i>sec.</i>
(1) North component	24	50	35.6	52.3	..	..	..	..
(2) East component	..	..	..	52.0	..	..	60	23
(3) North component	24	50	35 27	51 18	54	50	85 +	28
(4) East component	24	51	35 05	51 40	54	50	80 +	28
Average . . .	24	50	35 23	51 49	54	50		
Interval . . .	12	22	22 55	39 21	42	22		

Duration, 6 hours.

On account of the overlapping of the records on the seismogram of the East component of the Rebur-Paschwitz instrument the beginning of the first two phases can not be made out. There was a shifting of the median lines at about  $14^h$ , after which it exactly overlay the earlier line. The copyist has made the terminal part of the curve pass into the earlier part at about  $15^h 33^m$  ( $13^h 34^m$ ). The maximum amplitudes of the earth, as shown by the various instruments, approach the following values, tho the movements were not sufficiently regular to make the measures exact. (1) 1.7 mm.; (3) 2.7 mm.; (4) 2.2 mm. These maximums all occurred between  $13^h 50^m$  and  $13^h 57^m$ . The recording point passed its limits and ceased to record on (4) at the time when the amplitude was measured. (3) indicates an earth-amplitude of 3.65 mm. at  $13^h 53^m$ , during the long waves; the east component at that time is not sufficiently regular to yield a measure, but the total value must be greater than 4.

## GÖTTINGEN, GERMANY.

Geophysikalisches Institut der Universität. Prof. Dr. E. Wiechert, director.

Lat.  $51^{\circ} 33' N.$ ; long.  $9^{\circ} 58' E.$ ; altitude, 270 meters; distance,  $81.36^{\circ}$  or 9,0-10 km.; chord, 8,304 km.; direction, N.  $28^{\circ} E.$

Seismograms, sheet No. 12.

The instruments used, all having mechanical registration on smoked paper, were:

(1) Wiechert inverted pendulum, north component:  $T_m$  1.48 seconds;  $\lambda$ , 0.543 meter;  $V$ , 2,100;  $J$ , 1,140 meters;  $e$ , SA;  $r$ , 0.3 mm.;  $M$ , 17,000 kg.

Wiechert inverted pendulum, two components:

(2) North component:  $T_0$ , 14.07 seconds;  $V$ , 152;  $J$ , 7,500 meters;  $e$ , 3.9;  $r$ , 1.5 mm.;  $M$ , 1,200 kg.;  $I$ , 49 meters.

(3) East component:  $T_0$ , 12.6 seconds;  $J$ , 172;  $J$ , 6,700 meters;  $e$ , 3.4;  $r$ , 0.9 mm.;  $M$ , 1,200 kg.;  $I$ , 39.7 meters.

(4) Wiechert Vertical Motion Seismograph.  $T_0$ , 4.8 seconds;  $J$ , 170;  $J$ , 970 meters;  $e$ , 2.8;  $r$ , 0.1 mm.;  $M$ , 1,300 kg.;  $Z$ , 5.7 meters.

	FIRST PRELIMINARY TREMORS.		SECOND PRELIMINARY TREMORS.		REGULAR WAVES.		PRINCIPAL PART.			MAX.	AMPLITUDE.	PERIOD.
	<i>m.</i>	<i>s.</i>	<i>m.</i>	<i>s.</i>	<i>Tr.</i>	<i>s.</i>	<i>m.</i>	<i>s.</i>	<i>min.</i>			
(1) North component . . . . .	24	55	35	15	51	10	57	55 to 07.0	59	8.	18	20
(2) North component . . . . .	24	44	34	52	51	..	56	00 to 06.0	..	20	48+	17
(3) East component . . . . .	24	46	34	46	51	<i>ib</i>	55	54 to 10.0	..	..	40+	17
(4) Vertical component . . . . .	24	31	35	31	51	<i>ib</i>	..	..	05	..	15	16
Average . . . . .	24	44	35	06	51	05	56	36	15			
Interval . . . . .	12	16	22	38	38	37	44	08				

During the long waves, at 13<sup>h</sup> 54-54.5<sup>m</sup>, we find the following earth-amplitudes indicated: (1) North, 0.8mm.; (2) North, 0.97mm.; (3) East, 1.31 mm.; (4) Vertical, 1.64mm. at 13<sup>h</sup> 52-53<sup>m</sup>; probably the total would be about 2 mm. During the principal part: (1) North, 1.5 mm. at 13<sup>h</sup> 59<sup>m</sup> 20<sup>s</sup>; (2) North, 0.53 mm.; (3) East, 0.52 mm.; (4) Vertical, 0.7 mm., at 14<sup>h</sup> 06.5<sup>m</sup>. (2) and (3) give too small values for the pendulum struck against the stops during the large part of the principal part. It is to be noticed, however, that (1) gives a larger and (4) a smaller amplitude than during the long waves. Probably the maximum during the principal part was a little greater than 2 mm.

## COIMBRA, PORTUGAL.

Observatorio Magnetico-Meteorologico. Prof. A. S. Viegas, director.

Lat. 40° 12' N.; long. 8° 25' W.; altitude, 140.3 meters; distance, 81.39° or 9,049 km.; chord, 8,307 km.; direction, N. 45° E.

Foundation, Triassic sandstone.

Seismograms, sheet No. 1.

The instrument used was a Milne horizontal pendulum, east component; photographic registration;  $V$ , 6.1;  $M$ , 255 gm.

	FIRST PRELIMINARY TREMORS.	SECOND PRELIMINARY TREMORS.	REGULAR WAVES.	MAX.	AMPLITUDE.
East component . . . . .	<i>min.</i> 25.4	<i>min.</i> 35.0	<i>min.</i> 50.5	TO. «. 55 58	<i>mm.</i> 16
Interval . . . . .	12.9	22.5	38.0		

Duration, 3 hours. During the strong motion the period of the waves was about 24 seconds; the proper period of the pendulum is not known and the actual magnification can not be determined.

## LEIPZIG, GERMANY.

Kgl. Geologisches Bureau. Prof. Dr. Hermann Credner, director; Dr. F. Etwold, assistant.

Lat. 51° 20' N.; long. 12° 23.5' E.; distance, 82.40° or 9,161 km.; chord, 8,392 km.; direction, N. 26° E.

Foundation, alluvium and sands.

The instrument used was a Wiechert inverted pendulum, two components; mechanical registration on smoked paper.

(1) North component:  $T_0$ , 8.5 seconds; 7,220.6;  $J$ , 4,000 meters;  $\rho$ , 3.05;  $M$ , 1,100 kg.;  $U$ , 18.1 meters.

(2) East component:  $T_0$ , 8.5 seconds;  $V$ , 241;  $J$ , 4,350 meters;  $e$ , 2.4;  $M$ , 1,100 kg.;  $U$ , 18.1 meters.

	FIRST PRELIMINARY TREMORS.	SECOND PRELIMINARY TREMORS.	RECTOLAR WAVES.	PRINCIPAL PART.	MAX.	AMPLITUDE.	PERIOD.	EARTH'S AMPLITUDE.
(1) North component	<i>m. s.</i> 24 50	<i>m. s.</i> 35 39	<i>m. s.</i> 51 09	<i>min.</i> 56.0 to 06.3	<i>min.</i> 5 57.8 2 05.9	<i>mm.</i> 24 34	<i>sec.</i> 21 17	<i>mm.</i> 0.59 0.51
(2) East component	24 50	35 39	51 34	55.0 to 06.5	<i>m. s.</i> 5 55 41 5 57 28	64+ 64+	26 22	1.81+ 1.55+
Average . . .	24 50	35 39	51 21	<i>m. s.</i> 55 30				
Interval . . .	12 22	23 11	38 53	43 02				

Duration, 4.4 hours. At 13<sup>h</sup> 54<sup>m</sup> the long waves of north component had a period of about 40 seconds and an amplitude of 10 mm. This gives an amplitude on the north component of the earth-movement of about 1 mm.; at the same time the east component indicates an earth-amplitude of 1.2 mm., and the total may be 1.5 mm. At 13<sup>h</sup> 55<sup>m</sup> 41<sup>s</sup>, the east earth-amplitude is 1.81 mm. and the combined amplitude is 2.17 mm. At 13<sup>h</sup> 57.5<sup>m</sup> the north earth component is 0.58 and east component 1.55; total 1.65 mm. These amplitudes are not entirely trustworthy, because at times the instrument reached its limit and the motion was not very regular. At Plauen, a substation of Leipzig, and 90 km. to the south, the record resembled that at Leipzig.

The seismogram from Leipzig is reproduced in "Siebenter Bericht der Erdbebenstation Leipzig" (Ber. der Math. Phys. Kl. d. Kön. Sächsischen Gesells. d. Wissens. zu Leipzig. Bd. LIX, January 14, 1907). A copy of this was forwarded by Dr. Credner, but the seismogram was overlooked, and therefore is not reproduced in the atlas.

## JENA, GERMANY.

Stemwarte. Prof. Dr. Rudolph Straubel, director; Dr. Eppenstein, assistant.

Lat. 50°56'N.; long. 11° 35'E.; altitude, 155 meters; distance, 82.45° or 9,167 km.; chord, 8,396 km.; direction, N. 27° E.

Foundation, in the valley of the Saale River, on 4 to 5 meters of weathered sandstone, underlain by the Bunt sandstone.

Seismograms, sheet No. 11.

The instrument used was a Wiechert inverted pendulum, two components; mechanical registration on smoked paper.

(1) North component:  $T_0$ , 11.6 seconds;  $V$ , 160;  $J$ , 5,300 meters;  $e$ , 5.0;  $M$ , 1,200 kg.;  $U$ , 33.6 meters.

(2) East component:  $T_0$ , 11.6 seconds;  $F$ , 180;  $J$ , 6,000;  $e$ , 5.0;  $M$ , 1,200 kg.;  $U$ , 33.6 meters.

	FIRST PRELIMINARY TREMORS.	SECOND PRELIMINARY TREMORS.	REGULAR WAVES.	PRINCIPAL PART.	MAX.	AMPLITUDE.
(1) North component	<i>m. s.</i> 24 34	<i>m. s.</i> 35 09	<i>min.</i> 51.2	<i>min.</i> 56.5 to 07.5	<i>min.</i> 55.0 to 59.0	<i>mm.</i> 80+
(2) East component	24 34	35 09	51.2	56.8	58.0 to 00.	80+
Average . . .	24 34	35 00	<i>m. s.</i> 51 12	56 39		
Interval . . .	12 06	22 41	38 44	44 11		

Duration, 5.6 hours. From 54 to 56<sup>m</sup>, during the long waves the earth's amplitudes were the largest, being 2.6 mm. for the north and 1.9 mm. for the east component, a possible total of 3.2 mm. At about 59<sup>m</sup> the indicated earth's amplitudes are 2.0 mm. and 1.5 mm. for north and east components, respectively, and with a possible total of 2.5 mm.; but this is undoubtedly too small, as the instruments reached the stops.

## STRASSBURG, GERMANY.

Kais. Hauptstation für Erdbebenforschung. Prof. Dr. G. Gerland, director; Dr. E. Rudolph, assistant.

Lat. 48° 35' N.; long. 7° 46' E.; altitude, 135 meters; distance, 82.91° or 9,218 km.; chord, 8,434 km.; direction, N. 30° E.

Foundation, compact alluvial gravel.

Seismograms, sheet No. 14.

The instruments used were:

Rebeur-Ehlertriple pendulums, No. 2, two components; photographic registration.<sup>1</sup>

(1) N. 30° E. component; (2) E. component;  $T_0$ , 10 seconds;  $V$ , 45;  $J$ , 1,120 meters.

(3) Omori horizontal pendulum, east component.

Vicentini microseismograph, three components; mechanical registration on smoked paper.

(4) North and (5) east components. (6) Vertical component;  $V$ , 85; no damping and very slight friction.

(7) Schmidt trifilar gravimeter.

	FIRST PRELIMINARY TREMORS.		SECOND PRELIMINARY TREMORS.		REGULAR WAVES.	PRINCIPAL PART.	MAX.		AMPLITUDE.	PERIOD.	EARTH'S AMPLITUDE.
	<i>in.</i>	<i>s.</i>	<i>m.</i>	<i>s.</i>	<i>min.</i>	<i>min.</i>	<i>m.</i>	<i>s.</i>	<i>mm.</i>	<i>sec.</i>	<i>mm.</i>
(1) N. 30° E. component	24	52	35	18	51.2?	58.0	02	39	16.5	16	0.59
(2) East component .	25	06	35	28	$\frac{m}{46}$ 13	.. .	01	19	7.0	20	0.47
(3) East component .	24	51	35	17	46 36	.. .	07	27	4.4	12	
(4) North component .	..	..	..	..	48	.. .	01	25	2.0	22	
(5) East component .	24	53	35	18	46 05	.. .	02	35	2.0	18	
(6) Vertical component .	25	12	..	..	52	.. .	05	20	0.3	14	
(7) Vertical component	24	43	..	..	50 31	.. .	02	31	1.3	16	
Average . . . . .	24	57	35	20							
Interval . . . . .	12	29	22	52							

Duration, Rebeur, 2.5 to 3.5 hours; Omori, Vicentini, Schmidt, 1 to 2 hours. The possible maximum earth-amplitude is about 0.75 mm., according to the record of the Rebeur-Ehlertriple instrument.

The times, amplitudes, and periods are taken from the "Wöchentliches Erdbebenbericht der Kais. Hauptstation für Erdbebenforschung zur Strassburg," with the exception of the long waves, principal part and maximum of (1), which were obtained from the seismogram. It is evident that the various times under regular waves do not refer to the same phase.

## MOSCOW, RUSSIA.

Imperial University. Dr. Ernest Leyst, in charge of seismographs.

Lat. 55° 45' N.; long. 37° 34' E.; distance, 84.72° or 9,419 km.; chord, 8,584 km.; direction, N. 11° E.

Foundation, sand.

<sup>1</sup> The constants of these instruments are taken from the text accompanying "Seismogramme de nordpazifischen und sudamerikanischen Erdbebens am 16 August, 1906," a publication of the International Seismological Association. They probably also apply to April 18, 1906.

The instruments used were Bosch-Omori horizontal pendulums, two components; mechanical registration on smoked paper.

(1) North and (2) east components:  $T_0$ , 60 seconds;  $M$ , 10 kg.;  $L$ , 75 cm.<sup>1</sup>

	ITRBT PRELIMINARY TREMORS.	PRINCIPAL PART.	MAX.	AMPLITUDE.
(1) North component .	<i>min.</i> 28	<i>min.</i> 57 to 12	<i>min.</i> 59 to 01	<i>mm.</i> 150+ <sup>2</sup>
(2) East component .	51	54 to 04	57 to 03	150+ <sup>3</sup>

## MUNICH, GERMANY,

Kgl. Observatorium für Erdmagnetismus und Erdbebenstation. Dr. J. B. Messerschmitt, director.

Lat. 48° 09' N.; long. 11° 36.5' E.; altitude, 530 meters; distance, 84.75° or 9,423 km.; chord, 8,587 km.; direction, N. 29° E.

Seismograms, sheet No. 5.

The instrument used was a Wiechert inverted pendulum.

(1) North and (2) east components:  $T_0$ , 12.1 seconds;  $V$ , 200;  $J$ , 7,300 meters;  $e$ , 6.0;  $M$ , 1,000 kg.;  $U$ , 36.6 meters.

	FIRST PRELIMINARY TREMORS.	SECOND PRELIMINARY TREMORS.	REGULAR WAVES.	MAX.	AMPLITUDE.	PERIOD.	EARTH'S AMPLITUDE.
(1) North component	<i>m.</i> 25	<i>m.</i> 35	<i>TO.</i> 52	<i>min.</i> 04	<i>mm.</i> 80 +	<i>sec.</i> ?	<i>mm.</i> 0.8 +
(2) East component	<i>s.</i> 00	<i>a.</i> 26	<i>«.</i> 00	58	80 +	20	
Average . . .	25 00	35 34	51 43				
Interval . . .	12 32	23 06	39 15				

At 13<sup>h</sup> 52<sup>m</sup> the north component of the earth's movement is 0.47 mm., and the east component 1.26; a possible total of 1.35 mm.; this is during the long waves. During the principal part at 13<sup>h</sup> 58<sup>m</sup>, the east indicator went beyond the limits, indicating an earth-amplitude of more than 1.25 mm.; at the same time the north indicator showed an earth-amplitude of 0.77 mm.; that is, the total amplitude was possibly greater than 1.47 mm. At 14<sup>h</sup> 05<sup>m</sup> the north indicator exceeded the limits; and after that time no further record was made.

It is possible that the regular waves should be put about 4 minutes earlier; but the phase here taken is evidently the same as that taken for the regular waves at Jena.

## SAN FERNANDO, SPAIN.

Instituto y Observatorio de Marina. Capitan Thomas de Azcarate, director.

Lat. 36° 28' N.; long. 6° 12' W.; altitude, 28 meters; distance, 85.25° or 9,478 km.; chord, 8,628 km.; direction, N. 46° E.

Foundation, solid rock.

Seismograms, sheet No. 1.

The instrument used was a Milne horizontal pendulum, east component; photographic registration;  $T_0$ , 20 seconds;  $F$ , 0.1;  $J$ , 600 meters;  $e$ , 1.13;  $3f$ , 255 gm.;  $l$ , 15.6 cm.

<sup>1</sup> The times at Moscow are taken from an article by Or, E. Leyst in the Bulletin of the Naturalists of Moscow, Nos. 1 and 2, 1900. They are given to minutes only. It is evident that the beginning was not recorded, and the identification of the phases actually recorded is uncertain.

\*Off paper.

	FIRST PRELIMINARY TRBMOES.	SECOND PRELIMINARY TRBMOES.	REGULAR WAVES.	MAX.	AMPLITUDE.
East component . . .	25.1	35.3	48.5 or 53.7	57.9 104.2	17.5 + 17.5 +
Interval . . . . .	12.6	22.8	36.0 or 41.5		

The identification of the beginning of the regular waves is very doubtful.

TORTOSA, SPAIN.

Observatorio del Ebro. P. R. Cirera, S. J., director.

Lat. 40° 49' N.; long. 0° 30' E.; altitude, 38 meters; distance, 85.65° or 9,522 km.;  
chord, 8,660 km.; direction, N. 39° E.

Foundation, solid rock; cretaceous strata.

The instrument used was a Vicentini microseismograph, two horizontal components; mechanical registration on smoked paper.  $T_0$ , 1.8 seconds;  $J$ , 180;  $J$ , 1,450 meters;  $iW$ , 100 kg.;  $L$ , 1.43 meters.

	FIRST PRELIMINARY TREMORS.	SECOND PRELIMINARY TREMORS.	REGULAR WAVES.	MAX.	AMPLITUDE.	PERIOD.	EARTH'S AMPLITUDE.
Average . . . . .	<i>m.</i> 24 <i>a.</i> 55	<i>m.</i> 36 <i>a.</i> 00	<i>m.</i> 55 <i>a.</i> 00	18.0	3	16.4	1.36
Interval . . . . .	12 27	23 32	42 32				

Duration, 2.5 hours. If both components have the same maximum amplitude at the same time, the total earth-amplitude might be 1.82 mm.

KREMSMÜNSTER, AUSTRIA.

Observatoire des Benedictines. P. Franz Schwab, director.

Lat. 48° 03' N.; long. 14° 08' E.; altitude, 380 meters; distance, 85.77° or 9,535 km.;  
chord, 8,670 km.; direction, N. 27° E.

Foundation, about 20 meters of glacial till lying on Tertiary strata.

Seismograms, sheet No. 2.<sup>1</sup>

The instruments used were Ehlert horizontal pendulums (triple); photographic registration.

(1) N. 13° W. component:  $T_0$ , 10seconds;  $J$ , 81.4;  $J$ , 2,000 meters;  $e$ , 1.0;  $L$ , 10 cm.

(2) N. 47° E. component:  $JP_0$ , 10seconds;  $J$ , 76.7;  $J$ , 1,900meters;  $e$ , 1.0;  $L$ , 10cm.

(3) N. 73° W. component:  $T_0$ , 10 seconds;  $J$ , 81.4;  $J$ , 2,000meters;  $e$ , 1.0;  $L$ , 10 cm.

	FIRST PRELIMINARY TREMORS.	SECOND PRELIMINARY TREMORS.	PRINCIPAL PART.	MAX.	AMPLITUDE.
(1) N. 13° W. component.	24.4	38.3?	01.9?	37.5 106.8 139.1	13 18 23
(2) N. 47° E. component .	24.4	35.5	49.1?	01.6 105.8 140.8	31 26 10
(3) N. 73° W. component,	24.4	...	....	00.2 (05.8)	15 17
Average . . . . .	24.4	35.5			
Interval . . . . .	11.9	23.0			

<sup>1</sup> The middle record of the seismogram records the N. 47° E. component of the motion and not the N. 47° W. component as indicated.

Duration, 1.8 hours. The three Ehlert pendulums give very different effects. They all begin at closely the same time but the second group is well shown only on (2), the instrument which records the northeast movement, that is, at right angles to the direction of propagation; this indicates a transverse wave. It can be recognized on (1), recording the north-northwest component, at 38.3<sup>m</sup>, but not so clearly. The beginning of the regular waves is not recognizable; nor can we be sure of the time of beginning of the principal part.

The lines just below the seismograms are the records of a different hour.

#### KRAKAU, AUSTRIA.

K. K. Sternwarte, Prof. Dr. M. F. Rudski, director.

Lat. 50° 04' N.; long. 19° 58' E.; altitude, 205 meters; distance, 85.98° or 9,558 km.; chord, 8,687 km.; direction, N. 23° E.

Foundation, compact sandy clay alluvium.

Seismograms, sheet No. 13.

The instruments used were Bosch-Omori horizontal pendulums, two components; mechanical registration on smoked paper.

(1) Northwest component:  $T_0$ , 31.2 seconds;  $V$ , 10;  $\lambda$ , 2,400 meters;  $e$ , 1.0 (?);  $r$ , 2.8 mm. (?);  $M$ , 11 kg.;  $L$ , 75 cm.

(2) Northeast component:  $T_0$ , 25.8 seconds;  $V$ , 9.6;  $J$ , 1,600 meters;  $e$ , 1.24 (?);  $r$ , 2.1 mm. (?);  $M$ , 11 kg.;  $L$ , 75 cm.

	SECOND PRELIMINARY TREMORS.	REGULAR WAVES.	PRINCIPAL PART.	MAX.	AMPLI- TUDE.	PERIOD.
(1) Northwest component	mfn. 35.8	win. 54.5	min. 57.1	mfn. 00.9	mm. 20	sec 32
(2) Northeast component	35.6	53.6	58.0	59.2	55	24
Average	m. «. 35 42	m. a. 54 06	m. ». 57 33?			
Interval	23 14	41 38	45 07?			

Duration, northwest, 2.3 hours; northeast, 1.8 hours.

The beginning of the disturbance was not registered, tho very slight movements can be made out on the northwest component about 13<sup>h</sup> 27<sup>m</sup>; they are very slight and would not be recognized unless especially lookt for. The early motion (second preliminary tremors) is somewhat larger in the northwest than in the northeast component, indicating longitudinal waves; but this may be due to friction in the latter component. It is not entirely clear why the first preliminary tremors were not properly registered; the seismograms show that the northeast component had strong, solid friction which would be sufficient to prevent it from registering very small disturbances; but this condition is not so evident in the northwest component.

Dr. Rudski only gives the times to tenths of minutes on account of the uncertainty of the beginning of the different phases; but the clock-time is perfect. The periods during the strong motion are so close to the natural periods of the pendulum that we can not make a good determination of the earth's movement. The values of the damping ratios and the solid friction are determined from observations made long before the date of the earthquake.

#### GRANADA, SPAIN.

Observatorio de Cartuja. P. S. Navarro-Neumann, S. J., director.

Lat. 37° 11' N.; long. 3° 48' W.; altitude, 776 meters; distance, 86.08° or 9,570 km.; chord, 8,696 km.; direction, N. 44° E.

Foundation, piers are directly on Tertiary limestone.

Seismograms, sheet No. 14.



The instruments used were:

(1) Stiattesi horizontal pendulum, east component; mechanical registration on smoked paper.  $T_0$ , 17.6 seconds;  $V$ , 25;  $\lambda$ , 1,900 meters;  $M$ , 208 kg.;  $L$ , 1.75 meters.

(2) Vicentini microseismograph, east component; mechanical registration on smoked paper.  $T_0$ , 3.4 seconds;  $V$ , 155;  $\lambda$ , 450 meters;  $M$ , 312 kg.;  $L$ , 2.88 meters.

	FIRST PRELIMINARY TREMORS.	SECOND PRELIMINARY TREMORS.	REGULAR WAVES.	PRINCIPAL PART.	MAX.	AMPLITUDE.	PERIOD.	EARTH'S AMPLITUDE.
	<i>m. a.</i>	<i>m. «.</i>	<i>m. «.</i>	<i>min.</i>	<i>min.</i>	<i>mm.</i>	<i>sec.</i>	<i>mm.</i>
(1) East component	24 40	35 20	48 09	54.6 to 11.0	(58.0 ^05.8 (08.5	46 + ... ...	17.6 ... ...	... ... ...
(2) East component	24 40	35 20	** **	54.7 to 11.0	(55.2 ^57.2	28.1 16.7	4.2 4.0	1.8 0.6
Average Interval . . . .	24 40 12 12	35 20 22 52	48 09 35 31	<i>m. a.</i> 54 39 42 11				

Duration, 5.5 hours. The time of the regular waves is taken a little later than the time marked on the seismogram; it is evident that what is here taken for the beginning of the principal part is that of the regular waves on the Krakau, the Pavia, and the Vienna seismograms; it is accordingly so considered in the determination of velocity of propagation.

#### PAVIA, ITALY.

R. Osservatorio Geofisico. Dr. P. Gamba, director.

Lat.  $45^{\circ} 11' N.$ ; long.  $9^{\circ} 10' E.$ ; altitude, 81.7 meters; distance,  $86.20^{\circ}$  or 9,583 km.; chord, 8,707 km.; direction, N.  $32^{\circ} E.$

Foundation, Quarternary alluvium, about 200 meters thick.

Seismograms, sheet No. 7.

The instrument used was an Agamennone vertical pendulum, two horizontal components; mechanical registration with ink on paper.

(1) Northeast component:  $T_0$ , 6 seconds;  $V$ , 20;  $\lambda$ , 180 meters;  $e$ , 1.14;  $r$ , 0.38 mm.;  $M$ , 200 kg.;  $L$ , 8.96 meters.

(2) Southeast component:  $T_0$ , 6 seconds;  $V$ , 20;  $\lambda$ , 180 meters;  $e$ , 1.52;  $r$ , 1.05 mm.;  $M$ , 200 kg.;  $L$ , 8.96 meters.

	FIRST PRELIMINARY TREMORS.	SECOND PRELIMINARY TREMORS.	REGULAR WAVES.	PRINCIPAL PART.	MAX.	AMPLITUDE.	PERIOD.	EARTH'S AMPLITUDE.
	<i>m. a.</i>	<i>m. e.</i>	<i>m. s.</i>	<i>m. a. TO «.</i>	<i>m. ».</i>	<i>mm.</i>	<i>sec.</i>	<i>mm.</i>
(1) Northeast component	25 06	35 06	54 00	59 20 to 08 40	04 25	8.0	15	4.0
(2) Southeast component	24 46	.. ..	.. ..	02 30 to 08 30	f 03 15 106 25	10.0 9.5	16.0 13.8	5.0 3.0
Average Interval . . . .	24 56 12 28	35 06 22 38	54 00 41 32	00 55? 48 27?				

Duration, 2+ hours. The second group begins more sharply in the northeast than in the northwest component, *i.e.*, at right angles to the direction of propagation. The long waves are also better marked on this component and the principal part begins earlier and lasts longer, tho it has a slightly greater maximum on the other component. This is probably not a question of period, as both components have the same; but the less well-defined record of the southeast component is probably in part due to the greater friction; its value of  $r$  is more than twice that of the other component.

The period of the regular waves on the northeast component at 13<sup>h</sup> 56<sup>m</sup> is about 27 seconds; and amplitude 2.8 mm.; indicating an earth-amplitude of 2.7 mm. An earth-amplitude of 2.2 mm. is the maximum on the northeast component at 14<sup>h</sup> 04.4<sup>m</sup>; both of these maxima occur at times of minima on the northwest component. An earth-amplitude of 3 mm. is shown on the southeast component at 14<sup>h</sup> 03<sup>m</sup>; at this time the earth-amplitude on the northeast component is only about 1 mm., so that the total amplitude may be 3.3 mm.

## VIENNA, AUSTRIA.

K. K. Zentralanstalt für Meteorologie und Geodynamik. Prof. Dr. J. M. Pernter, director.

Lat. 48° 15' N.; long. 16° 21.5' E.; altitude, 200 meters; distance, 86.37° or 9,602 km.; chord, 8,719 km.; direction, N. 26° E.

Foundation, loam soil.

Seismograms, sheet No. 9.

The instrument used was a Wiechert inverted pendulum, two components; mechanical registration on smoked paper.

(1) North and (2) east components:  $T_0$ , 14 seconds;  $V$ , 250;  $J$ , 12,500 meters;  $\ll$ , 2.0;  $M$ , 1,000 kg.;  $U$ , 49 meters.

	FIRST PRELIMINARY TREMORS.		SECOND PRELIMINARY TREMORS.		REGULAR WAVES.		PRINCIPAL PART.		MAX.	AMPLITUDE.	PERIOD.	EARTH'S AMPLITUDE.	
	<i>m.</i>	<i>s.</i>	<i>m.</i>	<i>s.</i>	<i>m.</i>	<i>a.</i>	<i>min.</i>						
(1) North component . . . . .	<b>25</b>	<b>15</b>	36	08	53	58	58.0 to 11.5		<b>08</b>	<b>00</b>	<b>35</b>	18.8	0.11
(2) East component . . . . .	<b>25</b>	<b>15</b>	36	09	53	24	57.1		<b>59</b>	<b>35</b>	<b>30</b>	23.4	0.23
Average . . . . .	<b>25</b>	<b>15</b>	36	08	53	<b>41</b>	<i>m.</i>	<i>s.</i>					
Interval . . . . .	<b>12</b>	<b>47</b>	23	40	<b>41</b>	13	57	33					
							45	05					

Duration, 2.7 hours. The times of arrival of the regular waves is difficult to determine; it is possible, but not probable, that they should be taken about 6 minutes later. Tho the second group are also slightly questionable, the time given is probably correct. The earth-amplitude was slightly larger for the east component; it was 0.21 mm. at 13<sup>h</sup> 59.5<sup>m</sup> against 0.09 mm. for the north component; it was 0.14 mm. at 14<sup>h</sup> 04.5<sup>m</sup>, 14<sup>h</sup> 06.5<sup>m</sup>, and 14<sup>h</sup> 08<sup>fa</sup>; and for the north component it was 0.19 mm. at 13<sup>h</sup> 58.5<sup>m</sup> and 0.13 mm. at 14<sup>h</sup> 08<sup>m</sup>.

## SAL6 (BRESCIA), ITALY.

Osservatorio Geodinamico. Signor P. Bettoni, director.

Lat. 45° 36' N.; long. 10° 30' E.; distance, 86.42° or 9,608 km.; chord, 8,722 km.; direction, N. 31° E.

The instrument used was an Agamermone seismometrograph, northeast and northwest components; mechanical registration with ink on white paper.  $T_0$ , 7.8 seconds;  $V$ , 10;  $J$ , 150 meters;  $M$ , 220 kg.

A very faint movement is discernible at 13<sup>h</sup> 52<sup>m</sup>, which reaches a maximum of 2 mm. amplitude at 14<sup>h</sup> 05<sup>m</sup> on the northeast component. The greatest amplitude on the northwest component is only 0.2 mm. The transverse waves are therefore much stronger than the longitudinal. Earth-amplitudes can not be determined. The seismogram arrived too late for insertion in the atlas.

## LATBACH, AUSTRIA.

Erdbebenwarte. Prof. Dr. A. Belar, director.

Lat. 46° 03' N.; long. 14° 31' E.; distance, 87.22° or 9,697 km.; chord, 8,786 km.; direction, N. 29° E.

The instruments used were:

Ehlertriple pendulums, three components; photographic registration.

(1) North component:  $T_0$ , 3 seconds.(2) East component;  $T_0$ , 7 seconds.(3) Northeast component:  $T_0$ , 12 seconds.

Horizontal pendulum, two components.

(4) Northeast and (5) northwest components: this instrument consists of a box containing 40 kg. of stone pressing against a steel point and supported by a long wire; registration with ink on white paper;  $T_0$ , 20 seconds;  $V$ , 11;  $M$ , 40 kg.

Vicentini microseismograph; registration on smoked paper.

(6) North, (7) east, and (8) vertical components; 7,100.

Seismograph (construction not known).

(9) North and (10) east components;  $V$ , 12.6.

	FIRST PRELIMINARY TREMORS.		SECOND PRELIMINARY TREMORS.		PRINCIPAL PART.				MAX.		AMPLITUDE.	PERIOD.
	<i>m.</i>	<i>a.</i>	<i>m.</i>	<i>a.</i>	<i>m.</i>	<i>a.</i>	<i>m.</i>	<i>a.</i>	<i>m.</i>	<i>a.</i>	<i>mm.</i>	<i>sec.</i>
(1) North component . . .	25	25	35	38	..	..	..	..	..	..	.	..
(2) East component . . .	25	37	35	30	54	21 to 11	08	59	47	25*	.	..
(3) Northeast component .	25	30	35	21	54	10 to 10	00	59	52	30	.	..
(4) Northeast component <sup>1</sup>	26	52	36	47	52	17 to 11	20	02	42	5.5	.	23
(5) Northwest component <sup>1</sup>	26	31	36	25	52	38 to 11	32	02	52	6	.	..
(6) North component . . .	25	36	35	31	53	56 to 11	03	59	55	3.7	.	..
(7) East component . . .	25	34	35	29	54	09 to 10	57	59	52	3.0	.	..
(8) Vertical component . . .	25	37	35	32	54	15 to 12	00	00	02	1.0	.	..
(9) North component . . .	25	37	..	..	..	..	..	..	..	..	.	..
(10) East component . . .	25	38	..	..	..	..	..	..	..	..	.	..
Average . . . . .	25	34	35	30	54	10						
Interval . . . . .	13	06	23	02	41	42						

## TRIEST, AUSTRIA.

K. K. Maritimes Observatorium. Prof. Dr. Edu. Mazelle, director.

Lat. 45° 34' N.; long. 13° 46' E.; altitude, 67.5 meters; distance, 87.74° or 9,754 km.; chord, 8,828 km.; direction, N. 29° E.

Foundation, rock.

The instruments used were:

Ehlertriple pendulums (triple); photographic registration.

(1) North component:  $T_0$ , 12 seconds;  $V$ , 88;  $J$ , 3,150 meters;  $U$ , 35.8 meters;  $M$ , 200(?)gm.;  $L$ , 9.9 cm.(2) N. 60° W. component:  $T_0$ , 14 seconds;  $V$ , 84;  $J$ , 4,100 meters;  $M$ , 200 (?) gm.;  $L$ , 9.9 cm.(3) N. 60° E. component:  $T_0$ , 18 seconds;  $V$ , 88;  $J$ , 7,100 meters;  $U$ , 80.7 meters;  $M$ , 200(?)gm.;  $L$ , 9.9 cm.

Vicentini microseismograph, three components; mechanical registration on smoked paper.

(4) North and (5) east components:  $T_0$ , 2.41 seconds;  $V$ , 100;  $J$ , 143 meters;  $M$ , 100 kg.;  $L$ , 1.13 meters.<sup>1</sup> The records of this instrument were not used in making up the average, as they differ so materially from the others.

(6) Vertical component:  $T_0$ , 0.95 seconds;  $V$ , 100;  $J$ , 22.5 meters;  $M$ , 45 kg.;  $L$ , 1.50 meters.

	FIRST PRELIMINARY TREMORS.		SECOND PRELIMINARY TREMORS.		REGULAR WAVES.	MAX.	AMPLITUDE.	PERIOD.	
	m.	sec.	m.	sec.	m.	a.	min.	sec.	
(1) North component . . .	24	33	35	03	..	..	04.6	22	...
(2) N. 60° W. component . . .	25	28	35	34	..	..	05.8	40	...
(3) N. 60° E. component . . .	25	11	35	18	..	..	05.4	28	...
(4) North component . . .	25	26	35	47	45	30	05.7	2.0	18"
(5) East component . . .	..	..	36	18	49	31	03.0	1.5	18.9
(6) Vertical component . . .	..	..	..	..	..	..	05.7	0.5	17.5
Average . . . . .	25	09	35	36					
Interval . . . . .	12	41	23	08					

Duration, Ehlert, 3 hours; Vicentini, 2 hours. The movement on the vertical component began at 02<sup>m</sup> 51<sup>s</sup> with reinforcement at 05<sup>m</sup> 18<sup>s</sup>. The seismograms of the Vicentini instrument were too faint to reproduce, but we can determine from them the movements of the earth. At 14<sup>h</sup> 05.7<sup>m</sup> the earth's amplitude was: North, 1.1 mm.; east, 0.1 mm.; vertical, 0.9; total, 1.4 mm. At 14<sup>h</sup> 03<sup>m</sup>: North, 1.03; east, 0.9; vertical, 0; total, 1.4 mm. These amplitudes should be a little larger, as the seismograms from which they were determined were slightly reduced.

## BUDAPEST, HUNGARY.

Seismological Observatory of the University. Prof. Dr. R. de Kovesligethy, director. Lat. 47° 29.5' N.; long. 19° 04' W.; altitude, 110 meters; distance, 87.93° or 9,777 km.; chord, 8,846 km.; direction, N. 25° E.

Foundation, alluvium on Tertiary strata.

The instruments used were:

Bosch-Omori horizontal pendulum, north component:  $T_0$ , 23 seconds;  $V$ , 7, 9;  $J$ , 1,190 meters;  $M$ , 10 kg.;  $L$ , 75 cm.

Vicentini-Konkoly vertical pendulum.

North component:  $T_0$ , 2.45 seconds;  $V$ , 7, 44;  $J$ , 66 meters;  $M$ , 105 kg.;  $L$ , 1.5 meters.

East component:  $T_0$ , 2.45 seconds;  $V$ , 60;  $J$ , 90 meters;  $M$ , 105 kg.;  $L$ , 1.5 meters.

The clock controlling the time marks was not working, so that no time records were made; but the "Bulletin hebdomadaire des observatoires sismiques de la Hongrie et de la Croatie" gives the maximum amplitudes and the corresponding periods of the waves, which enables us to calculate the earth-amplitudes when the instruments recorded a maximum. We have:

Bosch-Omori, north component: amplitude, 22.3 mm.; period, 15 seconds; earth's amplitude, 1.42 mm.

Vicentini-Konkoly, north component: amplitude, 1.0 mm.; period, 26 seconds; earth's amplitude, 2.5 mm.

Vicentini-Konkoly, east component: amplitude, 0.55 mm.; period, 26 seconds; earth's amplitude, 1.06 mm.

## O'GYALLA, HUNGARY.

Seismological, Meteorological, and Geodynamic Observatory. Dr. N. Thege von Konkoly, director.

Lat. 47° 52' N.; long. 18° 12' E.; altitude, 111 meters; distance, 88.08° or 9,792 km.; chord, 8,856 km.; direction, N. 25° E.

Foundation, on a sandy plain.

The instruments used were:

Bosch-Omori horizontal pendulums, two components; mechanical registration on smoked paper.

(1) North component:  $T_0$ , 23 seconds;  $V$ , 10;  $J$ , 1,300 meters;  $e$ , 1.17;  $M$ , 11 kg.;  $L$ , 75 cm.

(2) East component:  $T_0$ , 21 seconds;  $V$ , 10;  $J$ , 1,050 meters;  $e$ , 1.17;  $M$ , 11 kg.;  $L$ , 75 cm.

Vicentini-Konkoly vertical pendulum, two components; mechanical registration on smoked paper.

(3) North component:  $T_0$ , 2.5 seconds;  $V$ , 41;  $J$ , 64 meters;  $e$ , 1.105;  $M$ , 105 kg.;  $L$ , 1.55 meters.

(4) East component:  $T_0$ , 2.5 seconds;  $V$ , 49;  $J$ , 76 meters;  $e$ , 1.105;  $M$ , 105 kg.;  $L$ , 1.15 meters.

	FIRST PRELIMINARY TREMORS.		SECOND PRELIMINARY TREMORS.		PRINCIPAL PART.		MAX.	PERIOD.	AMPLI- TUDE.	EARTH'S AMPLI- TUDE.	
	<i>m.</i>	<i>s.</i>	<i>m.</i>	<i>s.</i>	<i>m.</i>	<i>s.</i>	<i>m.</i>	<i>s.</i>	<i>mm.</i>	<i>mm.</i>	
(1) North component .	25	12	35	57	54	18	00	21	20	55 +	1.4
(2) East component .	25	28	36	20	52	59	06	32	18	43	1.26
(3) North component .	..	..	..	..	56	44?	02	01	17	0.3	0.33
(4) East component .	..	..	..	..	51	24	00	32	19	0.55	0.64
Average . . . . .	25	20	36	08							
Interval . . . . .	12	52	23	40							

Duration, (1) 2 hours; (2) 1.8 hours; (3) 36 minutes; (4) 54 minutes. There is little concordance in the times of the principal part, and in the absence of the seismograms these values can not be used in the determination of the velocity.

The times, periods, and amplitudes are taken from the "Bulletin hebdomadaire des observatoires sismiques de la Hongrie et de la Croatie"; and the earth-amplitudes are calculated. The smaller amplitudes of the Vicentini instrument are probably more reliable than those of the Bosch-Omori instrument, for the period of the latter is so nearly that of the waves that its magnifying power is very uncertain. On the other hand the Vicentini failed to record the first and second preliminary tremors, indicating a lack of sensitiveness, possibly due to friction.

The Vicentini instrument at Zagreb, 30 km. further from the origin than O'Gyalla, indicates much larger amplitudes, but they also are very uncertain.

#### FIUME, HUNGARY.

Seismological Observatory. Dr. P. Salcher, director.

Lat. 45° 20' N.; long. 14° 26' E.; altitude, 20 meters; distance, 88.17° or 9,802 km.; chord, 8,863 km.; direction, N. 29° E.

Foundation, folded Cretaceous limestones.

The instrument used was a Vicentini-Konkoly pendulum, two components; mechanical registration on smoked paper.  $V$ , 86;  $M$ , 100 kg.;  $L$ , 1.70 ± meters. The movement begins on both components (north and east) at 13<sup>h</sup> 40<sup>m</sup> and reaches a maximum, north 54<sup>m</sup> 18", amplitude 0.8 mm.; east, 55<sup>m</sup> 18", amplitude 1.5 mm. The disturbance lasted 27.5 and 47 minutes, respectively, on the north and east components. It is not clear what phase the beginning of the movement refers to.

## FLORENCE (XIMENIANO), ITALY.

Osservatorio Ximeniano. P. G. Alfani, S. J., director.

Lat. 43° 47' N.; long. 11° 15' E.; distance, 88.23° or 9,808 km.; chord, 8,868 km.; direction, N. 31° E.

Foundation, alluvium.

Seismograms, sheet No. 6.

The instruments used were:

Stiattesi horizontal pendulums. (1) North and (2) east components:  $T_Q$  40 seconds;  $V$ , 30;  $J$ , 12,000 meters;  $M$ , 500 kg.;  $L$ , 1.50 meters.

Vicentini microseismograph. (3) North and east components:  $T_Q$  2.4 seconds;  $V$ , 100;  $J$ , 143 meters;  $M$ , 450 kg.;  $L$ , 1.43 meters.

Omori tromometrograph. (4) Northeast and (5) northwest components:  $T_Q$  36 seconds;  $V$ , 25;  $J$ , 8,100 meters;  $M$ , 250 kg.;  $L$ , 50 cm.

All have mechanical registration on smoked paper.

	FIRST PRELIMINARY TREMORS.		SECOND PRELIMINARY TREMORS.		PRINCIPAL PART.		MAX.	AMPLITUDE.	PERIOD.	EARTH'S AMPLITUDE.
	<i>m.</i>	<i>a.</i>	<i>m.</i>	<i>a.</i>	<i>m.</i>	<i>a.</i>	<i>mm.</i>	<i>mm.</i>	<i>sec.</i>	<i>mm.</i>
(1) North component . . . .	26	25	37	15	49	20	10.0	135 +	17.6	4.1 +
(2) East component . . . .	26	25	37	20	45	10	07.0	100 +	17.6	2.6 +
(3) North and east components	26	25	37	05	56	00	<i>ra.</i> 59 <i>a.</i> 50	...	....	...
(4) Northeast components . .	26	25	36	55	48	15	10 55	75	19	2.8
(5) Northwest component . .	26	25	36	45	47	25	08 05	100	22	1.9
Average . . . . .	26	25	37	04						
Interval . . . . .	13	57	24	36						

There are no time marks on the record of the Omori instruments, (4) and (5). Assuming the time of beginning to be the same as that given by the other instruments, the times of the later phases are obtained from the rate of rotation of the recording drum.

## ZAGREB (AGRAM), HUNGARY.

Seismological Observatory. Prof. Dr. Mohorovicsics.

Lat. 45° 49' N.; long. 15° 59' E.; distance, 88.33° or 9,820 km.; chord, 8,877 km.; direction, N. 27° E.

The instrument used was a Vicentini-Konkoly vertical pendulum, two horizontal components; mechanical registration on smoked paper. (1) North and (2) east components. The constants are assumed to be about the same as those for O'Gyalla, namely:  $T_Q$  2.5 seconds;  $V$ , 40;  $J$ , 62 meters;  $M$ , 105 kg.;  $L$ , 1.55 meters.

	FIRST PRELIMINARY TREMORS.		SECOND PRELIMINARY TREMORS.		PRINCIPAL PART.		MAX.	AMPLITUDE.	PERIOD.	EARTH'S AMPLITUDE.
	<i>m.</i>	<i>a.</i>	<i>m.</i>	<i>a.</i>	<i>m.</i>	<i>a.</i>	<i>mm.</i>	<i>mm.</i>	<i>sec.</i>	<i>mm.</i>
(1) North component . . . .	25	33	35	21	53	16	01 09	2.2	21	3.9
(2) East component . . . .	25	17	35	42	53	16	01 04	1.6	21	2.8
Average . . . . .	25	25	35	31	53	16				
Interval . . . . .	12	57	23	03	40	48				

The earth-amplitudes are quite uncertain on account of the uncertainties of the constants of the instrument.

The times, periods, and amplitudes are taken from the "Bulletin hebdomadaire des observatoires sismiques de la Hongrie et de la Croatie."

## POLA, AUSTRIA.

K. K. Hydrographisches-Amt. Prof. Dr. August Gratzl, director.

Lat. 44° 52' N.; long. 13° 51' E.; distance, 88.34° or 9,821 km.; chord, 8,877 km.; direction, N. 29° E.

The instrument used was a Vicentini microseismograph, three components; mechanical registration on smoked paper. The seismogram was too faint for reproduction.

(1) North and (2) east components:  $T_0$ , 2.24 seconds;  $V$ , 110';  $J$ , 138 meters;  $e$ , 1.03;  $r$ , 0.1 mm.;  $M$ , 100 kg.;  $L$ , 125 cm.

(3) Vertical component:  $T_0$ , 0.92 second;  $V$ , 135;  $J$ , 29 meters;  $M$ , 50 kg.

	FIRST PRELIMINARY TREMORS.		SECOND PRELIMINARY TREMORS.		REGULAR WAVES.		PRINCIPAL PART.		MAX.		AMPLITUDE.		PERIOD.		EARTH'S AMPLITUDE.	
	<i>m.</i>	<i>s.</i>	<i>m.</i>	<i>a.</i>	<i>m.</i>	<i>a.</i>	<i>m.</i>	<i>s.</i>	<i>m.</i>	<i>s.</i>	<i>mm.</i>	<i>sec.</i>	<i>mm.</i>			
(1) North component	25	56	36	13	46	05	54	29	09	29	1.6	14	0.5			
(2) East component	..	..	..	..	..	..	53	59	02	11	2.5	21	1.9			
Average . . . .	25	56	36	13	46	05	54	14								
Interval . . . .	13	28	23	45	33	37	41	46								

Nothing is visible in the vertical component. The greatest earth-amplitude on the north component was 1 mm. at 14<sup>h</sup> 04.0<sup>m</sup>.

## QUARTO-CASTELLO (FLORENCE), ITALY.

Osservatorio Geodinamico di Quarto-Castello. Dr. Raffaello Stiattesi, director.

Lat. 43°49' N.; long. 11° 16' E.; altitude, 90 meters; distance, 88.40° or 9,828 km.; chord, 8,882 km.; direction, N. 31° E.

Foundation, directly on Upper Eocene limestone.

Seismograms, sheet No. 6.

The instruments used were Stiattesi horizontal pendulums, two components; mechanical registration on smoked paper.

(1) North component:  $T_0$ , 21A seconds;  $V$ , 50;  $J$ , 3,780 meters;  $M$ , 500 kg.;  $L$ , 1.80 meters.

(2) East component:  $T_0$ , 17 A seconds;  $V$ , 50;  $J$ , 5,700 meters;  $M$ , 500 kg.;  $L$ , 1.80 meters.

	FIRST PRELIMINARY TREMORS.		SECOND PRELIMINARY TREMORS.		REGULAR WAVES.		PRINCIPAL PART.		MAX.		AMPLITUDE.		PERIOD.		EARTH'S AMPLITUDE.	
	<i>m.</i>	<i>a.</i>	<i>m.</i>	<i>a.</i>	<i>m.</i>	<i>a.</i>	<i>m.</i>	<i>s.</i>	<i>min.</i>	<i>mm.</i>	<i>sec.</i>	<i>mm.</i>				
(1) North component	26	35	37	10	52	39?	58	36	04	255 +	30	10.2 +				
(2) East component	26	42	36	58	51	24	....		07	265 +	17	1.2 +				
Average . . . .	26	38	37	04	52	01?										
Interval . . . .	14	10	24	36	39	33?										

The periods are shown on the seismogram. It is not clear why so large a movement of the earth is indicated on the north component. The foundation is limestone, and other stations, not far distant, record much smaller displacements; and the east component indicates an earth-amplitude only about 0.1 as much. This large amplitude can not be accepted as true.

## ZI-KA-WEI, CHINA.

Meteorological, Magnetic, and Seismological Observatory. Rev. Louis Froc, S. J., director.

Lat.  $31^{\circ} 12' N.$ ; long.  $121^{\circ} 26' E.$ ; altitude, 7 meters; distance,  $88.49^{\circ}$  or 9,838 km.; chord, 8,889 km.; direction, N.  $50^{\circ} W.$

Foundation, alluvium.

Seismograms, sheet No. 15.

The instrument used was an Omori horizontal pendulum, east component; mechanical registration on smoked paper.  $T_0$ , 33.2 seconds;  $V$ , 15;  $\lambda$ , 4,100 meters;  $e$ , 1.07;  $r$ , 1.5 mm.;  $M$ , 15 kg.;  $L$ , 75.6 cm.

	FIRST PRELIMINARY TREMORS.		(6) SKCOND PRELIMINARY TREMORS.		(d) REGULAR WAVES.		MAX.	AMPLITUDE.	PERIOD.
	<i>m.</i>	<i>s.</i>	<i>m.</i>	<i>s.</i>	<i>m.</i>	<i>s.</i>	<i>min.</i>	<i>N.</i>	<i>sec.</i>
East component . . . .	25	24	35	36	56	00?	09	27	29.6
Interval . . . . .	12	56	23	08	43	32?			

The beginning of the movement is not shown on the seismogram, and the beginning of the long waves is not very clear. At  $58^m$  the period of the waves is 26.4 seconds and the recorded amplitude 20 mm.; the actual magnifying power is 40.5, making the earth-amplitude 0.5 mm. At  $09^m$  the period is 29.6 seconds, the recorded amplitude 27 mm., and the magnifying power 60; and therefore the earth's amplitude is only 0.45 mm.

## PILAR, ARGENTINA.

Observatorio Magnetico. W. G. Davis, director.

Lat.  $31^{\circ} 40' S.$ ; long.  $63^{\circ} 50.5' W.$ ; altitude, 340 meters; distance,  $88.75^{\circ}$  or 9,866 km.; chord, 8,909 km.; direction, S.  $47^{\circ} E.$

Foundation, compact alluvium.

Seismograms, sheet No. 1.

The instrument used was a Milne horizontal pendulum, east component.  $T_{01}$  15 seconds;  $\gamma$ , 6.1;  $J$ , 340 meters;  $e$ , 1.076;  $M$ , 255 gin.;  $L$ , 15.6 cm.

First preliminary tremors,  $25.6^m$ ; interval, 13.1 minutes. Maximum,  $36.8^m$ ; interval, 24.3 minutes. Amplitude, 0.2 mm.

Duration, 1.3 hours. It is impossible to determine the beginning of the motion from the reproduction of the seismogram; it is only possible to see a small swelling at the time of the maximum, which apparently occurs during the second preliminary tremors. It is not clear why the record should have been so small.

## URBINO, ITALY.

Osservatorio Meteorico-Sismico. Prof. T. Allipi, director.

Lat.  $43^{\circ} 43' N.$ ; long.  $12^{\circ} 38' E.$ ; distance,  $88.82^{\circ}$  or 9,875 km.; chord, 8,916 km.; direction, N.  $30^{\circ} E.$

The instrument used was an Agamennone vertical pendulum (modified), two horizontal components; mechanical registration with ink on white paper.  $T_0$ , 5 seconds;  $V$ , 24;  $\lambda$ , 150 meters;  $M$ , 112 kg.;  $L$ , 6.2 meters.

(1) North component:  $13^h 54^m 50'$  to  $14^h 16^m 00''$ .

(2) East component:  $13^h 56^m 40^s$  to  $14^h 11^m 00''$

Observations much too late; they probably represent only the principal part. The earlier phases were not recorded.



## ROCCA DI PAPA, ITALY.

It. Osservatorio Geodinamico. Prof. G. Agamennone, director.

Lat. 41° 46' N.; long. 12° 42' E.; altitude, 760 meters; distance, 90.48° or 10,061 km.; chord, 9,046 km.; direction, N. 32° E.

Foundation, volcanic rock.

Seismograms, sheet No. 14.

The instruments used were:

Microseismograph Agamennone, two components; mechanical registration with ink on white paper.

(1) Northwest component:  $T_0$ , 4.2 seconds;  $V$ , 60;  $L$ , 264 meters;  $e$ , 1.0;  $r$ , 0.38 mm.;  $M$ , 500 kg.;  $L$ , 4.39 meters.

(2) Northeast component:  $T_0$ , 4.2 seconds;  $V$ , 60;  $L$ , 264 meters;  $e$ , 1.0;  $r$ , 0.20 mm.;  $M$ , 500 kg.;  $L$ , 4.39 meters.

New microseismometrograph Agamennone (80 kg.), two components; mechanical registration on smoked paper.

(3) North and (4) east components:  $T_0$ , 2.6 seconds;  $V$ , 100;  $L$ , 168 meters;  $e$ , 1.0;  $r$ , 0.1 mm.;  $M$ , 80 kg.;  $L$ , 1.68 meters.

Cancani horizontal pendulums, two components; mechanical registration with ink on white paper.

(5) North component:  $T_0$ , 27.2 seconds;  $V$ , 1;  $J$ , 185 meters;  $e$ , 1.03;  $r$ , 0.0 mm.;  $M$ , 60 kg.;  $L$ , 1.00 meter (?).

(6) East component:  $T_0$ , 26.6 seconds;  $V$ , 1;  $L$ , 176 meters;  $e$ , 1.06;  $r$ , 0.0 mm.;  $M$ , 60 kg.;  $U$ , 1.76 meters;  $L$ , 1.00 meter(?).

	SECOND PRELIMINARY TREMORS.		REGULAR WAVES.		PRINCIPAL PART.		MAX.	AMPLITUDE.	PERIOD.	EARTH'S AMPLITUDE.
	m.	sec.	m.	sec.	m.	sec.				
(1) Northwest component	36	15	56	25?	..	..	07.3	3.2	19	1.15
(2) Northeast component	36	57	57	25?	57	29	10 11	2.0	17	0.5
(3) North component . .	..	..	57	50?	06	00	07 00	2.0	17	0.8
(4) East component . . .	35	46	58	14?	03	20?	07 30	2.0	17	0.8
(5) North component . .	36	34	57	50	59	15	05 20	12.5	26	
(6) East component . . .	37	00	57	15	01	25	04 14	15.0	27	
Average . . . . .	36	30	57	30						
Interval . . . . .	24	02	45	02						

Duration, 2 hours. The beginning of the motion on all the instruments was masked by vibrations due to high winds.

The seismograms are reproduced from tracings, which, in the case of the 80 kg. Agamennone seismograph, do not bring out the regularity and fineness of the original record on smoked paper. One sees, however, the short vibrations of the pendulum superposed on the larger earth vibrations. The greatest earth-amplitude was at 14<sup>h</sup> 07.3<sup>m</sup>; the 500 kg. seismograph indicates an amplitude of 1.1 mm. in the northwest direction, and the two components of the 80 kg. instrument indicate: North, 0.82 mm.; east, 1.14 mm.; a total amplitude of about 1.4 mm. in the northwest or northeast direction. These instruments therefore partially confirm each other and indicate that the maximum motion was in the line of propagation.

The Cancani horizontal pendulums have no damping; and since their natural periods correspond closely to those of the disturbance, no conclusion can be drawn from their record regarding the earth's amplitude.

## BELGRADE, SERVIA.

Royal Astronomical and Meteorological Observatory. Prof. Dr. M. Nedelkovitch, director.

Lat.  $44^{\circ} 48' N.$ ; long.  $20^{\circ} 09' E.$ ; distance,  $90.67^{\circ}$  or 10,080 km.; chord, 9,061 km.; direction, N.  $25^{\circ} E.$

Foundation, argillaceous alluvium, 130 meters thick, on Cretaceous limestones.

The instrument used was a Vicentini-Konkoly microseismograph, two components; mechanical registration on smoked paper.

(1) North component:  $T_Q$ , 2.4 seconds;  $V$ , 33;  $J$ , 47 meters;  $M$ , 105 kg.;  $L$ , 1.43 meters.

(2) East component:  $T_Q$ , 2.4 seconds;  $V$ , 48;  $J$ , 63 meters;  $M$ , 105 kg.;  $L$ , 1.43 meters.

Average: Second preliminary tremors,  $36^m 54^s$ ; interval,  $24^m 26^s$ . Maximum,  $02^m 51^s$ . Amplitude, 1.0 mm.

Duration, 1.9 hours.

## CARLOFORTE, SARDINIA, ITALY.

Stazione Astronomica Internazionale. Dr. L. Volta, director.

Lat.  $39^{\circ} 08' N.$ ; long.  $80^{\circ} 19' E.$ ; altitude, 18 meters; distance,  $90.71^{\circ}$  or 10,085 km.; chord, 9,067 km.; direction, N.  $36^{\circ} E.$

Foundation, trachitic rock.

The instrument used was a Vicentini microseismograph, two horizontal components; mechanical registration on smoked paper.

Northwest and northeast components:  $T_Q$ , 2.2 seconds;  $V$ , 50;  $J$ , 60 meters;  $e$ , 1.0;  $r$ , 0.1 (northwest component), 0.05 (northeast component);  $M$ , 100 kg.;  $L$ , 1.20 meters;

The original seismogram (too faint for reproduction) does not give clearly the times of the phases, but it shows, at  $14^h 07^m$ , waves of period 17 seconds and amplitude 0.5 mm.; as the magnifying power for these waves is 0.85, the earth's amplitude at that time was 0.6 mm., and since this amplitude was common to both components, the total possible amplitude of the earth's movement was 0.85 mm. At  $14^h 02^m$  the northeast component shows waves of period 20.4 seconds and amplitude 0.2 mm., indicating an amplitude of the earth in that direction of 0.34 mm. On the northwest component the amplitude is 0.2 mm., and period 27 seconds, therefore the earth's amplitude is 0.6 mm.; the movement at this time has a stronger component in the northwest direction, that is, in the direction of propagation.

## SARAJEVO, BOSNIA.

Meteorologisches Bureau. Herr Ph. Ballif, director; Herr Passinij, section chief.

Lat.  $43^{\circ} 52' N.$ ; long.  $18^{\circ} 26' E.$ ; altitude, 633 meters; distance,  $90.89^{\circ}$  or 10,104 km.; chord, 9,078 km.; direction, N.  $27^{\circ} E.$

Foundation, clay; on northern slope of a hill.

Seismograms, sheet No. 15.

The instrument used was a Vicentini microseismograph, two horizontal components; mechanical registration on smoked paper.

(1) North component:  $T_Q$ , 2.2 seconds;  $V$ , 156;  $J$ , 188 meters;  $M$ , 100 kg.;  $L$ , 1.20 meters.

(2) East component:  $T_Q$ , 2.2 seconds;  $V$ , 138;  $J$ , 166 meters;  $M$ , 100 kg.;  $L$ , 1.20 meters.

■

	SECOND PRELIMINARY TREMORS.		PRINCIPAL PART.		MAX.		AMPLITUDE.	PERIOD.	EARTH'S AMPLITUDE.
	TO.	8.	m.	8.	m.	8.	mm.	sec.	mm.
(1) North component	40	05	57	47?	03	40	0.4	30	0.47
(2) East component	33	10	54	16 ?	03	40	0.75	25	0.7
					14	39.5	1.0	20	0.6

Duration, 1 hour. The first preliminary tremors are not recorded, but a bell connected with a seismoscope rang at 13<sup>h</sup> 25<sup>m</sup>. The east component began to record earlier than the north, and thruout gave much larger amplitudes. The maximum movement of the ground was at 14<sup>h</sup> 03.7<sup>m</sup> and amounted to about 0.54 mm.; at 14<sup>h</sup> 10.5<sup>m</sup> it was 0.46 mm.; its direction was nearly east-west.

#### ISCHIA, ITALY.

R. Osservatorio Geodinamico di Casamicciola. Two installations, one at Porto d'Ischia and one at Grande Sentinella, about 3 km. apart. Prof. G. Grablowitz, director.

#### PORTO D'ISCHIA.

Lat. 40° 44' N.; long. 13° 57' E.; altitude, 31 meters; distance, 91.84° or 10,211 km.; chord, 9,153 km.; direction, N. 31° E.

Foundation, trachite.

Seismograms, sheet No. 7.

The instruments used were:

Grablowitz horizontal pendulums, two components:

(1) North component:  $T_0$ , 17 seconds;  $V$ , 8;  $J$ , 570 meters;  $e$ , 1.24;  $r$ , 0.8 mm.;  $M$ , 12 kg.;  $L$ , 8 cm.

(2) East component:  $T_0$ , 17 seconds;  $V$ , 8;  $J$ , 570 meters;  $e$ , 1.07;  $r$ , 0.2 mm.;  $M$ , 12 kg.;  $L$ , 8 cm.

Vasea Sismica, two horizontal components. This is a circular tank containing water; two floats are placed near the sides at ends of a north-south and of an east-west diameter respectively, and the movement of the water is magnified and recorded on a drum. The tank is 1.56 meters in diameter and the water is one meter deep. The movement of the north-south diameter is magnified 74.4 times, that of the east-west diameter 68.6 times.

#### GRANDE SENTINELLA.

Lat. 40° 45' N.; long. 13° 54' E.; altitude, 122 meters; distance, 91.83° or 10,210 km.; chord, 9,151 km.; direction, N. 31° E.

Foundation, volcanic tuff.

Seismograms, sheet No. 7.

The instruments used were:

(5) Grablowitz horizontal pendulum, east component:  $T_0$ , 12 seconds;  $V$ , 8;  $J$ , 290 meters;  $e$ , 1.18;  $r$ , 0.5 mm.;  $M$ , 12 kg.;  $L$ , 10 cm.

(6) and (7) Vasca Sismica, two components; it has the same dimensions as the tank at Porto d'Ischia.  $V$ , 90.7 for the north component and 97.3 for the east component.

All the instruments at both stations record on smoked paper.

	FIRST PRELIMINARY TREMORS.		SECOND PRELIMINARY TREMORS.		REGULAR WAVES.		PRINCIPAL PART.		MAX.		AMPLITUDE.	PERIOD.
	<i>m.</i>	<i>s.</i>	<i>m.</i>	<i>a.</i>	<i>m.</i>	<i>s.</i>	<i>m.</i>	<i>s.</i>	<i>m.</i>	<i>s.</i>	<i>mm.</i>	<i>sec.</i>
(1) North component . . . . .	..	..	36	49?	..	..	<b>07</b>	<b>00</b>	08	34	25	<b>17</b>
(2) East component . . . . .	..	..	..	..	..	..	<b>04</b>	<b>31</b>	08	27	50	<b>17</b>
(5) East component . . . . .	26	42?	<b>37</b>	<b>07</b>	56	24	<b>04</b>	<b>00</b>	10	25	<b>7.5</b>	<b>12.6</b>
Average . . . . .	26	42?	36	58	56	24						
Interval . . . . .	<b>14</b>	<b>14?</b>	24	<b>30</b>	43	56						

The vibrations of the water make it impossible to determine the phases from the Vasca Sismica either at Porto d'Ischia or at Grande Sentinella; at the former distinct waves of period about 18 seconds and amplitude 0.6 mm. occur from 14<sup>b</sup> 04.0<sup>m</sup> to 14<sup>b</sup> 18.0<sup>m</sup>. At Grande Sentinella, the waves are discernible at 13<sup>h</sup> 56.0<sup>m</sup>; a maximum with amplitude of nearly 1 mm. is reached at 14<sup>b</sup> 07.0<sup>m</sup>; the periods are from 18 to 24 seconds.

During the strong motion the periods of the vibrations recorded by the Grablowitz pendulums are the same as those of the pendulums themselves; namely, 17 seconds at Porto d'Ischia and 12 seconds at Grande Sentinella. If we attempt to find the earth-amplitudes by using the values of the damping and friction, we find 0.33 mm. or less; but it is evident that the regular movement did not continue long enough to allow the pendulums to take their full amplitudes.

## CAGGIANO (SALERNO), ITALY.

Osservatorio Meteorologico-Geodinamico. Signor P. Allard, director.

Lat. 40° 54' N.; long. 15° 30' E.; altitude, 831 meters; distance, 92.63° or 10,297 km.; chord, 9,213 km.; direction, N. 30° E.

The instrument used was an Agamennone seismometrograph, northwest and southwest components; mechanical registration with ink on white paper.  $T_0$  6 seconds;  $V$ , 12.5;  $J$ , 112 meters;  $M$ , 200 kg.;  $L$ , 8.95 cm.

	SECOND PRELIMINARY TREMORS.		REGULAR WAVES.		MAX.		AMPLITUDE.	PERIOD.	EARTH'S AMPLITUDE.
	<i>m.</i>	<i>s.</i>	<i>m.</i>	<i>a.</i>	<i>m.</i>	<i>a.</i>	<i>mm.</i>	<i>sec.</i>	<i>mm.</i>
Northwest component . . . . .	36	<b>40</b>	<b>56</b>	<b>46</b>	<b>04</b>	<b>10</b>	<b>0.9</b>	<b>22</b>	<b>0.95</b>
Interval . . . . .	<b>24</b>	<b>12</b>	<b>44</b>	<b>18</b>					

At 13<sup>b</sup> 59.5<sup>m</sup> the long waves on the northwest component had an amplitude of 0.4 mm. and a period of 32 seconds, corresponding to an earth-amplitude of 1 mm. At 14<sup>b</sup> 07.3<sup>m</sup> the northwest earth-amplitude was 0.68 mm. The northeast component was not perfectly free and was less sensitive than the northwest, so that the times can not be made out reliably; but notwithstanding this it indicated an earth-amplitude of 2.2 mm. at 14<sup>b</sup> 04.2<sup>m</sup>; denoting the strongest motion at right angles to direction of propagation.

The seismogram arrived too late for reproduction.

## TAIHOKU, FORMOSA, JAPAN.

Meteorological Observatory. H. Kondo, director.

Lat. 25° 04' N.; long. 121° 31' E.; altitude, 10 meters; distance, 92.75° or 10,311 km.; chord, 9,222 km.; direction, N. 55° W.

Foundation, clay.

Seismograms, sheet No. 15.

The instrument used was an Omori horizontal pendulum, east component; mechanical registration on smoked paper.  $T_0$ , 17 seconds;  $V$ , 10;  $l$ , 720 meters;  $e$ , 1.27;  $r$ , 0.13

mm.;  $M$ , 6 kg.;  $L$ ,  $76 \pm$  cm. The times on the seismogram are  $a$ ,  $13^h 38^m 52^s$ ;  $b$ ,  $13^h 56^m 20^s$ ;  $c$ ,  $14^U 20^m 27^s$ ;  $d$ ,  $15^U 00^m 48^s$ .

	(a) PRELIMINARY TREMORS.		(b) REGULAR WAVES.		MAX.	AMPLITUDE.	PERIOD.	EARTH'S AMPLITUDE.
	<i>m.</i>	<i>a.</i>	<i>m.</i>	<i>a.</i>	<i>min.</i>	<i>mm.</i>	<i>sec.</i>	<i>mm.</i>
East component . . . . .	28	52	56	20	0.0	3.5	22	0.25
Interval . . . . .	16	24	43	52				

The time of the beginning is evidently too late. It is probable that the earth-amplitude was greater than calculated, as the large vibration lasted for a very short time.

## SOFIA, BULGARIA.

Central Meteorological Institute. Dr. Spas Watzof, director.

Lat.  $42^\circ 42'$  N.; long.  $23^\circ 20'$  E.; altitude, 550 meters; distance,  $93.58^\circ$  or 10,404 km.; chord, 9,286 km.; direction, N.  $24^\circ$  E.

Foundation, sands and sandy shales.

Seismograms, sheet No. 13.

The instruments used were Bosch-Omori horizontal pendulums, two horizontal components; mechanical registration on smoked paper.

(1) North component:  $T_o$ , 20.8 seconds;  $V$ , 10.1;  $J$ , 108 meters;  $e$ , 1.0;  $r$ , 2.7 mm.;  $M$ , 10 kg.;  $L$ , 74 cm.

(2) East component:  $T_o$ , 31.0 seconds;  $V$ , 10.1;  $J$ , 2,400 meters;  $e$ , 1.0;  $r$ , 4.0 mm.;  $M$ , 10 kg.;  $L$ , 74 cm.

	(a) FIRST PRELIMINARY TREMORS.	(6) SECOND PRELIMINARY TREMORS.	REGULAR WAVES.	PRINCIPAL PART.	MAX.	AMPLITUDE.	PERIOD.
	<i>min.</i>	<i>min.</i>	<i>min.</i>	<i>min.</i>	<i>min.</i>	<i>mm.</i>	<i>sec.</i>
(1) North component	25.00	35.5	57.5	03.0	04.7 to 05.8	50 +	21.9
(2) East component	.....	36.0	56.7	.....	.....	60 +	28.9
Average . . . . .	25.00	35.45	57.06				
Interval . . . . .	12.32	23.17	44.38				

During the long waves at  $14^h 01.5^m$ , the north earth-amplitude was 0.48 mm. During the maximum movement of the pendulums the periods of vibration correspond very nearly to the proper periods of the pendulums; we can not therefore determine the earth's movement. It is very difficult to determine the times of the first and second preliminary tremors accurately; nor is it clear where we should place the beginning of the regular waves.

## MESSINA, SICILY, ITALY.

Instituto di Fisica terrestre e Meteorologia della R. Università. Prof. B. G. Rizzo, director.

Lat.  $38^\circ 12'$  N.; long.  $15^\circ 33'$  E.; altitude, 46 meters; distance,  $94.67^\circ$  or 10,524 km.; chord, 9,368 km.; direction, N.  $32^\circ$  E.

Seismograms, sheet No. 12.

The instrument used was a Vicentini microseismograph, three components; mechanical registration on smoked paper.

(1) Northeast component:  $T_o$ , 2.4 seconds;  $V$ , 100;  $J$ , 143 meters;  $M$ , 106 kg.;  $L$ , 1.43 meters.

(2) Northwest component:  $T_o$ , 2.4 seconds;  $V$ , 100;  $J$ , 143 meters;  $e$ , 1.04;  $M$ , 106 kg.;  $L$ , 1.43 meters.

(3) Vertical component:  $T_{Q_1}$  1.8 seconds;  $V$ , 120;  $J$ , 97 meters;  $\epsilon$  1.14;  $M$ , 56 kg.

The records were greatly disturbed by the wind so that the times of arrival of the first two phases were entirely lost; the long waves appear at  $13^h 55.5^m$  on the northwest component. The greatest movement of the earth occurred during the principal part, at  $M_2$  ( $14^h 07.8^m$ ); when we find

	AMPLITUDE.	PERIOD.	EARTH'S AMPLITUDE.
	<i>mm.</i>	<i>sec.</i>	<i>mm.</i>
Northwest component . . .	2.0	22	1.66
Northeast component . . .	0.4	21	0.30
Vertical component . . .	0.2	22	0.25

As a possible maximum of the earth-amplitude we have 1.7 mm. During the long waves, at  $14^h 04.7^{01}$ , the period was 30 seconds, and the earth-amplitude 0.93 mm. The letters on the seismogram correspond to times as follows:  $M_v$   $14^h 04.3^m$ ;  $M_2$ ,  $14^h 07.8^m$ ;  $M_8$ ,  $14^h 10.1^m$ ;  $M_{\downarrow}$   $14^h 12.7^m$ .

CATANIA, SICILY, ITALY.

R. Osservatorio di Catania ed Etneo. Prof. A. Riccd, director.  
 Lat.  $37^{\circ}30'$  N.; long.  $15^{\circ}05'$  E.; altitude, 42 meters; distance,  $95.04^{\circ}$  or 10,567 km.;  
 chord, 9,396 km.; direction, N.  $32^{\circ}$  E.  
 Foundation, lava.  
 Seismograms, sheet No. 13.

The instrument used was a long vertical pendulum, two horizontal components; mechanical registration with ink on white paper.

(1) Northeast component:  $T_{Q_1}$  10 seconds;  $V$ , 12.5;  $J$ , 310 meters;  $e$ , 1.01;  $r$ , 0.4 mm.;  $M$ , 300 kg.;  $L$ , 24.9 meters.

(2) Northwest component:  $T_{Q_1}$  10 seconds;  $V$ , 12.5;  $J$ , 310 meters;  $e$ , 1.026;  $r$ , 0.5 mm.;  $M$ , 300 kg.;  $L$ , 24.9 meters.

	FIRST PRELIMINARY TREMORS.		SECOND PRELIMINARY TREMORS.		REGULAR WAVES.		PRINCIPAL PART.		MAX.	AMPLITUDE.	PERIOD.	EARTH'S AMPLITUDE.
	<i>m.</i>	<i>a.</i>	<i>m.</i>	<i>s.</i>	<i>m.</i>	<i>t.</i>	<i>m.</i>	<i>s.</i>				
(1) Northeast component	26	05	37	27	56	24	04	45	12	51	18	0.72
(2) Northwest component	26	05	35	23	..	..	06	50	07	08	18	0.72
Average . . . . .	26	05	36	25?	56	24	05	48?				
Interval . . . . .	13	37	23	57?	43	56	53	20?				

At the times of the maximum on each component the movement is comparatively small on the other component, so that the total earth-amplitude would not be more than about 0.8 mm. The northwest component shows signs of friction; this may be the reason why it does not bring out the long waves, and why the principal part is of somewhat shorter duration than on the northeast component.

RIO DE JANEIRO, BRAZIL.

Observatorio de Rio de Janeiro. Dr. H. Morize, director.  
 Lat.  $22^{\circ} 54'$  S.; long.  $43^{\circ} 10'$  W.; altitude, 44 meters; distance,  $96.28^{\circ}$  or 10,703 km.; chord, 9,488 km.; direction, S.  $66^{\circ}$  E.  
 Foundation, decomposed gneiss.

The instruments used were Bosch-Omori horizontal pendulums, two horizontal components; mechanical registration on smoked paper.  $M$ , 15 kg.;  $V$ , 15.

The solid friction was so strong that it rendered the pendulums almost aperiodic and masked the details of the motion; for this reason the seismogram is not reproduced. The first movement discernible on the east component is at 13<sup>h</sup> 39.7<sup>m</sup>; and on the north component at 13<sup>h</sup> 54<sup>m</sup>. The total duration is nearly an hour.

## WELLINGTON, NEW ZEALAND.

Department of Education. G. Hogben, director.

Lat. 41° 17' S.; long. 174° 47' E.; altitude, 15 meters; distance, 97.62° or 10,853 km.; chord, 9,588 km.; direction, S. 42° W.

Foundation, directly on the "Wellington Slates" near the edge of a cliff, 15 meters high, near Wellington Harbor.

Seismograms, sheet No. 2.

The instrument used was a Milne horizontal pendulum, east component; photographic registration.  $T_0$ , 18.6 seconds;  $V$ , 6.1;  $J$ , 525 meters;  $e$ , 0.14;  $M$ , 255 gm.;  $L$ , 15.6 cm.

	FIKBT PRELIMINARY TREMORS.	SECOND PRELIMINARY TREMORS.	PRINCIPAL PART.
East component. . . . .	<i>min.</i> 26.6	<i>min.</i> 36.8	<i>min.</i> 02.2 (?)
Interval . . . . .	14.1	24.3	49.7 (?)

## CALAMATE, GREECE.

National Astronomical Observatory. Prof. Dr. D. Eginitis, director.

Lat. 37° 02' N.; long. 22° 15' E.; altitude, 32 meters; distance, 98.28° or 10,927 km.; chord, 9,636 km.; direction, N. 28° E.

Seismograms, sheet No. 15.

The instrument used was an Agamennone vertical pendulum, two horizontal components; mechanical registration with ink on white paper.  $T_0$ , 6.95 ± seconds;  $V$ , 12;  $J$ , 144 meters;  $M$ , 200 kg.;  $L$ , 1.44 m.

The disturbance began at 14<sup>h</sup> 02<sup>m</sup> 06<sup>s</sup> and lasted 18 minutes. Evidently the preliminary tremors were not recorded, but only the principal part, whose interval is 49<sup>m</sup> 38<sup>s</sup>.

## TIFLIS, CAUCASIA, RUSSIA.

Physical Observatory. Herr S. von EQasek, director.

Lat. 41° 43' N.; long. 44° 48' E.; distance, 99.43° or 11,054 km.; chord, 9,719 km.; direction, N. 9° E.

The instruments used were:

Ehlertr triple horizontal pendulum, photographic registration.

Milne horizontal pendulum, photographic registration, east component.

Bosch-Omori horizontal pendulums, two components; mechanical registration on smoked paper.

Two heavy Zöllner horizontal pendulums.<sup>1</sup>

First preliminary tremors, 26<sup>m</sup> 09<sup>s</sup>; interval, 13<sup>m</sup> 41<sup>s</sup>. Second preliminary tremors, 37<sup>m</sup> 59<sup>s</sup>; interval, 25<sup>m</sup> 31<sup>s</sup>.

## TASCHKENT, RUSSIAN TURKESTAN.

Astronomical and Physical Observatory. M. Ossipoff, director.

Lat. 41° 20' N.; long. 69° 18' E.; altitude, 478 meters; distance, 99.86° or 11,102 km.; chord, 9,750 km.; direction, N. 9° W.

Foundation, stiff loess.

<sup>1</sup> The times are taken from "Die Erdbebenwellen" by Drs. Wiechert and Zoeppritz. Nach. d. Gesell. d. Wissen. Glittingen, Math. Phys. Kl. 1907. No further information is given.

The instruments used were:

Repsold-Zöllner horizontal pendulums, two components; photographic registration. Seismograms, sheet no. 2.

(1) North component:  $T_0$ , 9.2 seconds; F, 59; J, 1,240 meters; M, 59.1 gm.; L, 13 cm.

(2) East component:  $T_0$ , 7.94 seconds; V, 60; J, 940 meters; M, 59.1 gm.; L, 12.7 cm.

Bosch-Omori horizontal pendulums, two components; mechanical registration on smoked paper. Seismograms, sheet No. 13.

(3) North and (4) east components:  $T_0$ , 12 seconds; F, 10 (?); J, 360 (?) meters; M, 11 kg.; L, 75 cm.

	HHBT PRE- LIMINARY TREMORS.	SECOND PRELIMINARY TREMORS.	REGULAR WAVES.	PRINCIPAL PART.	MAX.	AMPLI- TUDE.	PERIOD.	EARTH'S AMPLI- TUDE.
(1) North component	<i>min.</i> 26.5	<i>min.</i> (31.0)	<i>min.</i> (43.0)	m. a. .....	m. a. .....	<i>mm.</i> 80 +	<i>sec.</i> .....	<i>mm.</i> .....
(2) East component	(30.7)	37.8	48.4	.....	.....	80 +	.....	.....
(3) North component	.....	<i>m.</i> <i>a.</i> 36 56	<i>m.</i> <i>a.</i> 53 20	<i>m.</i> <i>a.</i> (09 56)	<i>m.</i> <i>a.</i> 10 56	10	<b>24</b>	3.0
(4) East component	(5L26)	(59 06)	(06 08)	(14 27)	(21 21)	33	<b>32</b>	.....
Average	26.5	37 22						
Interval	14.0	24 54						

The times in parentheses are not used, as they are evidently erroneous; the cause is unknown; the times of (4), for instance, are all much too late, but I can not discover the cause. (4) also indicates an earth-amplitude of 20 mm., which is impossible.

#### CHRISTCHURCH, NEW ZEALAND.<sup>1</sup>

Magnetic Observatory. Henry F. Skey, B. Sc, director.

Lat. 43° 3# S.; long. 172° 37' E.; distance, 100.40° or 11,162 km.; chord, 9,788 km.; direction, S. 42° W.

The instrument used was a Milne horizontal pendulum, east component; photographic registration. V, 6.1; M, 255 gm.; L, 15.6 cm.

East component: Second preliminary tremors, 33.6<sup>m</sup>; interval, 21.1 minutes. Regular waves, 01.0<sup>m</sup>, interval, 48.5 minutes. Maximum, 30.0<sup>m</sup>. Amplitude, 6.8 mm. Duration, 3.3 hours.

#### MANILA, PHILIPPINE ISLANDS.

Manila Central Observatory. Rev. Jose<sup>a</sup> Algue<sup>a</sup>, S. J., director.

Lat. 14° 35' N.; long. 120° 59' E.; altitude, 10 meters; distance, 100.46° or 11,169 km.; chord, 9,793 km.; direction, S. 118° W.

Foundation, sand 14 meters thick over volcanic tuff.

Seismograms, sheet No. 4.

The instrument used was a Vicentini microseismograph, two horizontal and vertical components; mechanical registration on smoked paper. East-northeast component:  $T_0$ , 2.4 seconds; J, 100; J, 1,430 meters; M, 100 kg.; L, 1.43 meters.

	FIRST PRE- LIMINARY TREMORS.	REGULAR WAVES.	MAX	AMPLI- TUDE.	PERIOD.
East-northeast component	<i>m.</i> <i>a.</i> 22 44	01.0	<i>min.</i> 08.0	<i>mm.</i> <b>0.9</b>	<i>sec</i> 18
Interval	10 16	48.5			

<sup>1</sup> The times are taken from Circular 15, issued by the Seismological Committee of the British Association for the Advancement of Science.



Duration, 3 hours. The time of the beginning is evidently too early; the smallness of the motion makes it quite impossible to determine the precise time. The north-northwest component (not reproduced) gives a record very similar to the other, but with a somewhat smaller amplitude. The maximum instrumental amplitude is at 14<sup>h</sup> 08.0<sup>m</sup>, when the earth-amplitude was (ENE.) 0.44 mm., (NNW.) 0.4 mm., or a possible total of 0.6 mm. Data are not at hand to determine the vertical earth movement, tho the instrumental amplitude was 0.25 mm. A larger earth-amplitude occurred during the long waves; we find, at 14<sup>h</sup> 01.0<sup>m</sup>, earth-amplitudes (ENE.) 0.75 mm., (NNW.) 0.45 mm., or a possible total of 0.87 mm. If instead of a short-period pendulum there had been one with a period in the neighborhood of 25 seconds, the record would have been very large at this time; and if the period had been about 20 seconds, the record would have been very large at 14<sup>h</sup> 08.0<sup>m</sup>; as it is, with a period of 2.4 seconds, the record is quite small. The strong contrast between the seismograms of Manila and that of Potsdam, on the same plate, is principally due to the periods of the pendulums at the respective places. At Potsdam the period was 18 seconds.

## TADOTSU', JAPAN.

Meteorological Observatory. N. Maeda, director.

Lat. 34° 17' N.; long. 133° 46' E.; altitude, 6 meters; distance, 101.30° or 11,262 km.; chord, 9,852 km.; direction, N. 55° W.

The instrument used was an Omori horizontal pendulum; mechanical registration on smoked paper.  $M$ , 10 kg.;  $V$ , 20;  $L$ , 75 cm.<sup>1</sup>

First preliminary tremors, 25<sup>m</sup> 07<sup>s</sup>; interval, 12 minutes 39 seconds.

## CAIRO, EGYPT.

Helwan Observatory. H. H. Wade, director.

Lat. 29° 52' N.; long. 31° 20.5' E.; altitude, 115 meters; distance, 107.92° or 11,998 km.; chord, 10,302 km.; direction, N. 23° E.

Foundation, directly on Eocene limestones; in the desert about 5 km. from the Nile. Seismograms, sheet No. 1.

The instrument used was a Milne horizontal pendulum, east component; photographic registration.  $T_0$ , 15 seconds;  $V$ , 6.1;  $l$ , 340 meters;  $e$ , 1.054; angular displacement, 1 mm. = 0.5<sup>''</sup>;  $M$ , 255 gm.;  $L$ , 15.6 cm.

	FIRST PRELIMINARY TREMORS.	SECOND PRELIMINARY TREMORS.	MAX.	AMPLITUDE.
East component . . .	<i>min.</i> 31.0?	<i>min.</i> 39.0?	14*34.0-»	<i>mm.</i> 4.0
Interval . . .	18.5?	26.5?		

Duration, 3.5 hours. Only a drawing of the seismogram was available; this and the indefinite character of the seismogram make it impossible to obtain accurate time determinations of the various phases. The beginning of the first preliminary tremors are evidently too late, but the time of the second preliminary tremors seems about right.

<sup>1</sup> The constants are taken from Professor Omori's Report on the Great Indian Earthquake. "Pub. Earthquake Investigation Commission in Foreign Language, No. 24." The time is taken from Bulletin of the same Commission, vol. 1, No. 1.

## CALCUTTA, INDIA.

Alipore Meteorological Observatory. G. W. Kiichler, assistant meteorological reporter.  
Lat.  $22^{\circ} 32' N.$ ; long.  $88^{\circ} 20' E.$ ; altitude, 6.5 meters; distance,  $112.72^{\circ}$  or 12,531  
km.; chord, 10,607 km.; direction, N.  $31^{\circ} W.$

Foundation, marshy alluvium; 100 km. from the sea, and far from mountains.  
Seismograms, sheet No. 1.

The instrument used was a Milne horizontal pendulum, east component; photographic registration.  $T_o$ , 18 seconds;  $V$ , 6.1;  $J$ , 490 meters;  $e$ , 1.10; angular displacement, 1 mm. = 0.38";  $M$ , 255 gm.;  $L$ , 15.6 cm.

	FIRST PRE- LIMINARY TREMORS.	SECOND PRE- LIMINARY TREMORS.	REGU- LAR WAVES.	MAX.	AMPLI- TUDE.
East component . . .	<i>T</i> <sub>in</sub> . 29.2?	<i>t</i> <sub>in</sub> . 39.4	<i>min</i> . 05.6?	<i>min</i> . 17.3	<i>mm</i> . 17
Interval . . .	16.7?	26.9	53.1?		

Duration, 4.1 hours. It is difficult to determine the exact time of beginning, as there was a slight disturbance of the beam. The time of the second preliminary tremors is less doubtful.

## BOMBAY, INDIA.

Government Observatory. N. A. F. Moos, director.

Lat.  $18^{\circ} 54' N.$ ; long.  $72^{\circ} 49' E.$ ; altitude, 11 meters; distance,  $121.19^{\circ}$  or 13,472  
km.; chord, 11,099 km.; direction, N.  $17^{\circ} W.$

Foundation, basaltic trap.

The instruments used were:

(1) Milne horizontal pendulum, east component; photographic registration. Seis-  
mograms, sheet No. 2.  $T_o$ , 18 seconds;  $V$ , 6.1;  $J$ , 490 meters; angular displacement,  
1 mm. = 0.47";  $M$ , 255 gm.;  $L$ , 15.6 cm.

Colaba horizontal pendulums, two components; mechanical registration with ink on  
paper. Seismograms, sheet No. 15.

(2) North component:  $T_o$ , 24 seconds;  $V$ , 3;  $J$ , 430 meters; angular displacement,  
1 mm. = 0.27";  $M$ , 25 kg.;  $L$ ,  $92 \pm$  cm.

(3) East component:  $T_o$ , 37 seconds;  $V$ , 5;  $J$ , 1,700 meters; angular displacement,  
1 mm. = 0.14";  $M$ , 25 kg.;  $L$ ,  $92 \pm$  cm.

Each one of the Colaba pendulums consists of a mass of about 25 kg., supported on a  
horizontal beam about 90 cm. long. The solid friction is large, sufficient to stop the  
vibration of the pendulum in a single vibration if its amplitude is not more than a few  
millimeters.

	S»com>PHB- LMIKART TREMORS.	<i>W</i> <sub><i>x</i></sub> <i>r</i> <i>m</i> .	MAX.	AMPW TTOS.
(1) East component . . .	40.8	<i>min</i> . 11.8	<i>min</i> . 34.1	<i>mm</i> . 6.3
(2) North component . . .	42.5?	...	27.9	3.6
(3) East component . . .	42.5T	...	29.0	4.0
Average . . . . .	40.8	11.8		
Interval . . . . .	28.3	59.3		

Duration, 3.4 hours. (1) gives a better value of the time of arrival of the second  
preliminary tremors than the average on account of the strong fraction of (2) and (3);  
and therefore its value is used in preference to the average of the three installment!. The

time of arrival of the regular waves is doubtful; at the time given there is a change in the general character of the record, the irregular phase becoming more regular and the amplitude larger. The friction alters the magnifying power very materially; in the absence of precise knowledge of its value we can not estimate the earth's amplitude.

## BATAVIA, JAVA.

Royal Magnetic and Meteorological Observatory. Dr. W. van Bemmelen, acting director.

Lat.  $6^{\circ} 11' S.$ ; long.  $106^{\circ} 50' E.$ ; altitude, 3 meters; distance,  $124.99^{\circ}$  or 13,897 km.; chord, 11,300 km.; direction, S.  $112^{\circ} W.$

Foundation, alluvium.

Seismograms, sheet No. 15.

The instrument used was a Rebeur-Ehler horizontal pendulum, north component; photographic registration.  $T_o$ , 9.4 seconds;  $F$ , 65.5;  $J$ , 1,440 meters;  $e$ , 1.15;  $M$ , 200 gm. (?);  $L$ , 12.2 cm.

	FIRST PRELIMINARY TREMORS.		SECOND PRELIMINARY TREMORS.		REGULAR WAVES.		MAX.	PERIOD.	AMPLITUDE.	EARTH'S AMPLITUDE.
	m.	s.	m.	a.	m.	«.				
North component . . . . .	32	54	42	16	14	22	mm.	sec.	mm.	mm.
Interval . . . . .	20	26	29	48	61	54	30.6	16	6	0.18

The instrument was not still when the disturbance arrived; from an examination of the photographic copy of the seismogram it seems probable that the first preliminary tremors began at  $29^h 34^m$ , giving an interval of 17 minutes 06 seconds. During the regular waves an amplitude of 4.5 mm. was reached at  $14^h 17.5^m$ , when the earth's amplitude amounted to 0.38 mm. This was the maximum earth movement. During the principal part at  $14^h 30.6^m$ , the earth-amplitude was 0.24 mm.

## KODAIKAWAL, MADRAS, USDIA.

Solar Physics Observatory. C. Michie Smith, director.

Lat.  $10^{\circ} 14' N.$ ; long.  $77^{\circ} 28' E.$ ; altitude, 2,343 meters; distance,  $127.96^{\circ}$  or 14,226 km.; chord, 11,449 km.; direction, N.  $26^{\circ} W.$

Foundation, directly on solid rock.

Seismograms, sheet No. 2.

The instrument used was a Milne horizontal pendulum, east component; photographic registration.  $T_o$ , 15 seconds;  $V$ , 6.1;  $r$ , 340 meters;  $e$ , 1.115;  $r$ , 0.0 mm.;  $M$ , 255 gm.;  $L$ , 15.6 cm.

First preliminary tremors,  $31.6^m$  (?); interval, 19.1 minutes (?). Maximum,  $28.8^m$ . Amplitude, 2.5 mm.

The position of this station has been misplaced on the map. It should be about 2 mm. from the southern point of India and equidistant from the sea, east and west.

## PERTH, WESTERN AUSTRALIA.

Astronomical Observatory. W. Ernest Cooke, M.A., F. R. A. S., government astronomer.

Lat.  $31^{\circ} 57' S.$ ; long.  $115^{\circ} 50' E.$ ; altitude, 59.5 meters; distance,  $132.37^{\circ}$  or 14,716 km.; chord, 11,656 km.; direction, S.  $78^{\circ} W.$

Foundation, sand on limestones.

Seismograms, sheet No. 2.

The instrument used was a Milne horizontal pendulum, east component; photographic registration.  $T_0$ , 15 seconds;  $V$ , 6.1;  $J$ , 340 meters;  $e$ , 1.083;  $M$ , 255 gm.;  $L$ , 15.6 cm.

Second preliminary tremors (?), 37.6<sup>m</sup>; interval, 25.1 minutes. Regular waves, 18.3<sup>m</sup>; interval, 65.8 minutes. Maximum amplitude, 2.0 mm.

A glance at the seismogram will show the difficulty of getting satisfactory determinations of the times of arrival of the first two phases. The beginning at 13<sup>h</sup> 37.6<sup>m</sup> certainly does not correspond with the beginning of the first preliminary tremors as this phase would be, for moderate and large distances, much weaker than was recorded at Perth; it is possible that this time refers to the second preliminary tremors. The times given accord with the marks on the seismogram; but in Circular 14 of the Seismological Committee of the British Association for the Advancement of Science, the corresponding times are 2.4 minutes earlier.

## CAPE OF GOOD HOPE, AFRICA.

Royal Observatory. Sir David Gill, director.

Lat. 33° 56' S.; long. 18° 29' E.; altitude, 7 meters; distance, 148.63° or 16,524 km.; chord, 12,266 km.; direction, S. 86° E.

Foundation, weathered Paleozoic rocks.

Seismograms, sheet No. 1.

The instrument used was a Milne horizontal pendulum, east component; photographic registration.  $T_0$ , 12 seconds;  $V$ , 6.1;  $J$ , 220 meters; angular displacement, 1 mm. = 0.21";  $M$ , 255 gm.;  $L$ , 15.6 cm.

	PRELIMINARY TREMORS.	REGULAR WAVES.	MAX.	AMPLITUDE.
East component . . .	<i>min.</i> 36.5?	<i>min.</i> 33.5?	<i>min.</i> 34.0	<i>mm.</i> 0.2
Interval . . . . .	24.0?	81.0?	81.5	

The record is extremely small and is not brought out in the reproduction of the seismogram. On the photographic copy of the seismogram the line shows a slight swelling beginning at 13<sup>h</sup> 36.5<sup>m</sup>, and a few long-period waves begin at 14<sup>h</sup> 33.5<sup>m</sup>. It does not appear why this record is so much smaller than those of Perth and Mauritius.

## ISLAND OF MAURITIUS.

Royal Alfred Observatory. T. F. Claxton, director.

Lat. 20° 06' S.; long. 57° 33' E.; altitude, 51 meters; distance, 162.02° or 18,012 km.; chord, 12,601 km.; direction, N. 1° W.

Seismograms, sheet No. 2.

The instrument used was a modified Milne horizontal pendulum, two components; photographic registration.

(1) North component:  $T_0$ , 20.4 seconds;  $V$ , 11;  $J$ , 1,140 meters;  $e$ , 1.042; angular displacement, 1 mm. = 0.39";  $M$ , 310± gm.;  $L$ , 15 cm. (?)

(2) East component:  $T_0$ , 20.4 seconds;  $V$ , 8;  $J$ , 830 meters;  $e$ , 1.007; angular displacement, 1 mm. = 0.25";  $M$ , 340± gm.;  $L$ , 13 cm. (?)

Preliminary tremors, 41.2<sup>m</sup> (?); interval, 28.7<sup>m</sup> (?). Regular waves, 36.3<sup>m</sup> (?); interval 83.8 minutes (?). Maximum, 50.0<sup>m</sup>. Amplitude, 5.0 mm.

Duration, 3.3 hours. The times given do not specify the component, but apparently refer to the east component, as the north seismogram is not very clear. There is a con-

siderable increase in intensity at 13<sup>h</sup> 58.3<sup>m</sup>, but it is not evident what it refers to. The time of the long waves is very doubtful.

The instrument is an ordinary Milne horizontal pendulum with the beam pointing to the east; to the supporting column a second pendulum is attached pointing south; this is about 10 cm. long and carries a weight. A long light beam carrying the diaphragm is attached at right angles to this pendulum, so that the two records are made side by side on the same photographic paper. The diaphragms are cut down to a width of 6 or 7 mm.; and the slit in the box, thru which the light passes, is closed at intervals of 2 mm., so that a series of white lines appears on the record. One of these white lines lies almost in the center of the record of the north component.

Mauritius is slightly misplaced on the map (plate 1); it should lie in the southeast angle between the lines marking 20° S. latitude and the red north-south line, thru the antipodes of the origin and practically touching these two lines.

## THE SEISIOGKAI AND ITS ELONGATION,

### EARLIER EXPLANATIONS.

On examining the seismograms, we notice that many of them can readily be divided into a number of well-defined parts. The movement begins as a slight vibration, known as the *first preliminary tremors* or the *first phase*; after an interval, dependent upon the distance of the station from the origin, there is a marked strengthening of the motion; this is called the *second preliminary tremors* or *second phase*; very soon the motion becomes quite irregular. After a second interval, also dependent upon the distance of the station, the irregularities gradually die down, giving place to waves of long period, 25 to 50 seconds, which may have a large amplitude; at many stations the largest earth-amplitudes occur during this phase. The time when these waves take on a fairly regular form can usually be identified with some accuracy and is therefore taken as the time of arrival of the *regular waves*. It is a little later than the *long waves* of Professor Omori and a little earlier than the *large waves* of Professor Milne. I have adopted this point, as I found it in general more easily identifiable, in the various seismograms, than those just mentioned; tho in some seismograms it is difficult to determine accurately where the regular waves begin. In a few cases it is not clear that there are any regular waves at all. This phase does not last long, but it is quickly followed by waves of shorter period, 15 to 20 seconds, during which the pointer is apt to record its greatest amplitude, and which has, therefore, been called the *large waves* or *principal part*; it dies down with more or less irregularity until quiet is restored. This may require several hours, tho the earthquake at the origin may have lasted less than a minute.

A number of hypotheses have been advanced to account for the increasing duration of the disturbance as the distance of the station from the origin is greater. In the first place, it is the general belief, first suggested by Prof. K. D. Oldham,<sup>1</sup> that the first preliminary tremors are due to longitudinal waves, the second preliminary tremors to transverse waves, these two being propagated thru the body of the earth; and that the long waves and principal part are due to waves transmitted along the surface; altho some seismologists think that all waves are transmitted around the earth at or near the surface. A part of the record, near its end, is, in some cases, due to surface waves which have past around the earth and have approached the station from the antipodes.

As longitudinal waves advance more rapidly than transverse the interval between them naturally increases with the distance of propagation. This is the most satisfactory explanation of the increasing interval between the two phases, but according to it we should have two groups of waves separated from each other by a period of quiet; whereas, in reality, we have a continuous disturbance; and, moreover, observation does not confirm the idea that the first and second preliminary tremors consist solely of longitudinal and transverse waves, respectively.

It has also been suggested that repeated reflections from the earth's surface would cause a succession of impulses; but in this case also they would be discontinuous. Still, it is most probable that some of the sudden strengthenings of the movement are due to the arrival of these reflected waves.

---

<sup>1</sup> On the Propagation of Earthquake Motion, to Great Distances. PML Trans. R. S. 1900-1901, vol. 194, pp. 135-174.

An explanation has been sought by supposing that waves of various periods are present in the disturbance and that they are propagated at various rates, just as light waves of different wave-lengths travel at different speeds in transparent substances. Altho the slow periods of the regular waves change into the quicker periods of the principal part, this change does not seem to continue during the remainder of the disturbance; nor has a similar change been discovered during the first two phases.

#### A NEW EXPLANATION.

The passage of sound thru air suggests a better analogy. A strong sound, like the firing of a cannon or a clap of thunder, is not heard at a distance as a sharp noise, but is accompanied by a rumbling that lasts for many seconds; this is due to reflections and refractions of the sound at the surfaces of many layers of air of varying temperature, etc. Now the material of the earth for a few kilometers from the surface consists of rocks of varying density and elasticity; and when an elastic wave crosses the bounding surface between two different materials, it is in general split up into four waves, reflected longitudinal and transverse waves, and refracted longitudinal and transverse waves. When the reflected waves, returning, meet a boundary between different kinds of rock, they are again reflected and send waves forward, which are, however, retarded behind the original wave. In this way, by repeated reflections and refractions, a large part of the energy of the original wave would be, as it were, stored up in the heterogeneous surface layer of the earth and be slowly given out, thus keeping up a continuous supply at the surface for a limited time.

If the whole earth were sufficiently heterogeneous, we should not have, at distant stations, the distinction between first and second preliminary tremors, for there would be thruout the whole course of the waves such frequent transformations from longitudinal to transverse waves and *vice versa*, that they would arrive at a distant station thoroly mixed, and the supply of energy there would be fairly continuous, without the sudden variation which actually marks the arrival of the second phase. But we believe that, with the exception of a surface layer a few kilometers thick, the earth is fairly homogeneous, or, rather, without sudden changes in density or elasticity; and that an earthquake will set up both longitudinal and transverse vibrations, which will travel at different speeds and become entirely separated from each other in the homogeneous interior. When the longitudinal waves reach the heterogeneous layer near the surface they will be broken up; at every refracting surface both longitudinal and transverse waves will be sent forward; as the former always travel the faster, they will arrive first at the earth's surface; but, in general, the transverse waves, set up at the last refracting surface, will not be far behind them. The proportion of longitudinal and transverse waves in the first preliminary tremors, at a given station, will probably depend upon special characteristics of the rock in the neighborhood and also on the direction from which the waves come; for transformations depend on the angle between the vibrations and the refracting surface. In regions of stratified rocks such surfaces are very numerous and are usually parallel with each other; their influence would vary in accordance with the direction in which the vibrations met them. It might thus be possible for the first preliminary tremors to consist almost wholly of longitudinal waves, or to consist of both kinds equally; but it does not seem possible that transverse waves could predominate in them.

Let us now turn our attention to the group of transverse waves traveling by themselves in the homogeneous interior of the earth. They fall farther and farther behind the longitudinal waves; when they reach the heterogeneous outer layer they also suffer transformations, giving rise to both longitudinal and transverse waves, and these, by continual

reflections and refractions, prolong the time during which this group reaches the surface. In this group, as in the first, the proportion of longitudinal and transverse vibrations reaching the surface may vary between wide limits; but the longitudinal waves can never predominate. However, the first vibrations of the group will be longitudinal; for at the first refracting surface which the waves meet longitudinal waves will, in general, be generated, and will immediately advance at a higher speed, always keeping ahead of any transverse waves that they may develop. These waves, like the leaders of the first group, are apt to be weakened by reflections and transformations and may fail of recognition when they are superposed on the later vibrations of the first group. The time of arrival of the first group is dependent on the speed of the longitudinal waves, from start to finish; but that of the second group depends on the speed of transverse waves in the homogeneous interior and of longitudinal waves in the heterogeneous outer layer.

We do not know enough about the interior of the earth to fix the thickness of the outer heterogeneous layer, nor to say whether severe earthquakes originate in it or below it; tho the former seems the more probable. We have for simplicity of statement assumed the latter, but this is by no means necessary. If the earthquake originated in the heterogeneous layer, both groups of waves would suffer some elongation before they reached the homogeneous interior and after they left it; but they would travel without change so long as they were in it. If there is a central metallic core in the earth, changes would, of course, take place when the waves cross its boundary.

#### THE STRONGER TRANSVERSE WAVES.

If the outer layer of the earth were sufficiently thick or sufficiently heterogeneous, longitudinal and transverse vibrations of the preliminary tremors might become so mixed in it that the first and second phases would not be distinguishable; but nevertheless, the two kinds of waves would separate from each other in the homogeneous interior and at distant stations the two phases would appear. But the fact that the second phase is so much stronger than the first at all stations, including those  $30^\circ$  or  $40^\circ$  from the origin, which are too near for the difference to be accounted for by the vertical component of the longitudinal motion, indicates that the outer homogeneous layer by no means destroys the distinction between longitudinal and transverse waves in the first two phases; and that the transverse waves are originally much stronger than the longitudinal. This may be due to the way in which the waves originate at the fault-surface. When the rupture occurs there, the friction of one side against the other is probably the chief means of starting the vibrations, and evidently would produce stronger transverse than longitudinal waves.

#### THE SEPARATION OF THE FIRST TWO PHASES.

The distinction of the first two phases would exist from the very start, but they would naturally reach a near station only a few seconds apart; and if the original shock lasted longer than this interval and underwent considerable variations in intensity, the arrival of the first preliminary tremors, due to successive parts of the shock, might mask the arrival of the second. Moreover, and this fact is perhaps still more important, few instruments are provided with very open time-scales, a necessary condition to show the separation of the phases near the origin. Fortunately the Ewing three-component seismograph at Mount Hamilton met this requirement; its time-scale was 6 or 7 mm. to the second and it was therefore quite competent to show the interval of 9 seconds which separated the beginnings of the first two phases. Mount Hamilton, at a distance of 128 km. from the origin, was the nearest station provided with a time-marking record. At Victoria (distant  $10.41^\circ$  or 1,156 km.) the smallness of the time-scale and the overlapping



of vibrations from various parts of the fault-plane make it impossible to recognize the second phase; but at Sitka ( $20.72^\circ$  or 2,302 km.), and at more distant stations, the second phase is distinct. So far, therefore, as the observations of the California earthquake are concerned, there is no reason to believe that the first two phases are not distinct from their starting-point; and the reason this has not been recognized heretofore may be entirely due to the small time-scale of the instruments.

#### THE DIRECTION OF MOTION.

Let us see how far the observed directions of motion support the above explanation of the elongation of the first two phases. The duplex seismographs of Berkeley and Mount Hamilton indicate the direction of the beginning of the motion; they show that the first movement of the ground at these stations was directed away from the origin. The extent of the fault-surface soon caused waves to come from many directions, so that the recorded movement became confused almost immediately; but at Mount Hamilton there were two longitudinal vibrations before other waves materially interfered with their direction. The seismogram of the three-component Ewing instrument shows, when we consider the arrangement of the recording pens, that the first and second preliminary tremors began there with a movement southeast and northwest, that is, along the direction of propagation. These two were the only stations near the earthquake's origin which yielded definite information regarding the direction of motion at the beginning of the shock. And of all the records at distant observatories there are comparatively few which throw light on this subject; because only a very few instruments were so oriented as to record separately the vibrations parallel with, and at right angles to, the course of the waves. The stations in the eastern part of the United States were well situated for this purpose, as the waves were moving almost directly eastward when they past them. Ottawa and Cheltenham each recorded the longitudinal waves (east component) about 13 seconds before the transverse, and the longitudinal waves also were somewhat stronger during the first preliminary tremors. In the second group, transverse waves (north component) were recorded at Cheltenham 9 seconds earlier than the longitudinal; and they seem very slightly stronger. The northern component of the second group in the Ottawa seismogram overlaps other parts and can not be clearly read; but it seems to be somewhat stronger than the eastern component. The Albany record does not yield definite results, and the other stations in this neighborhood only recorded one component of the motion.

The waves arrived at the majority of the European observatories in a direction making angles between  $30^\circ$  and  $40^\circ$  with the meridian; and as by far the larger number of the instruments recorded either north-south or east-west motion, they would be affected about equally and would not distinguish between longitudinal and transverse waves. A few instruments, however, were oriented so as to make the distinction. The triple Ehlert instrument at Uccle began to record at the same moment with all three components, but the longitudinal waves (N.  $60^\circ$  W.) were stronger during the first preliminary tremors, and the transverse (N.  $60^\circ$  E.) during the second preliminary tremors. At Kremsmünster the longitudinal waves (distributed between the two components, N.  $13^\circ$  W. and N.  $73^\circ$  W.) seem stronger during the first preliminary tremors, and the transverse (N.  $47^\circ$  E.) during the second preliminary tremors. At Rocca di Papa the longitudinal vibrations (NW.) in the second preliminary tremors were registered 42 seconds before the transverse (NE.), according to Professor Agamennone's reading of the original record. At Messina, the transverse (NE.) vibrations in the second preliminary tremors were somewhat stronger than the longitudinal.

The waves approach Taschkent and Jurjew making a small angle with the meridian. No difference can be made out for the two components during the first and second preliminary tremors at Taschkent, but at Jurjew the east-west component was larger for both. The waves approach Mauritius exactly from the north; and it is the most distant station from the origin ( $162^\circ$ ). The earlier part of the motion was distinctly stronger on the north-south component; and this preponderancy lasted during the first part of the second preliminary tremors; but it must be remembered that the time of beginning of this phase is somewhat doubtful. On the other hand, we find the east-west motion, at Tacubaya, stronger for the first two phases, altho the direction of propagation was practically symmetrical with respect to the two components. At Upsala the east-west movement was slightly more marked during the first preliminary tremors and the north-south during the second preliminary tremors, tho the opposite would have been expected. At Potsdam, Jena, and Göttingen the north-south movement was slightly the stronger during the second preliminary tremors, also contrary to expectation.

This is the very meager evidence which the records of the earthquake offer regarding the direction of motion during the preliminary tremors. It is not entirely consistent, but it indicates on the whole that longitudinal vibrations were preponderant during the first preliminary tremors, and transverse during the second preliminary tremors; but that both kinds of motion existed practically during the whole of the preliminary tremors; and therefore the evidence can be said to favor the theory advanced to explain the drawing out of the record.<sup>1</sup>

We must remember that transverse vibrations may have any direction around the direction of propagation, and in particular may lie in the vertical plane thru this direction; the horizontal projection of their motion would then lie in the direction of propagation of the disturbance along the surface, and they would be recorded as tho they were longitudinal waves. This may explain the longitudinal direction of the strong motion at Mount Hamilton, tho the movement on the fault-plane would lead us to expect transverse waves more nearly in a horizontal plane.

#### THE PRINCIPAL PART AND THE TAIL.

It is generally believed that the surface waves are also drawn out more and more as the distance of the station is greater; but an examination of the seismograms of the California earthquake does not support this view. It is very difficult to determine what should be considered the principal part and what the tail portion of the seismogram; but on making the best estimate we can of the principal part, we find no regularity in its duration; and we also find very different results according to the type of instrument recording. For instance, at Taschkent, one would estimate about 2.5 hours for the principal part from the Repsold-Zöllner instrument, and 15 minutes from the Bosch-Omori. At Baltimore (distant  $35.7^\circ$ ) a Milne pendulum makes the duration of the principal part about 47 minutes; whereas Bosch-Omori instruments at Washington ( $35.4^\circ$ ) and Cheltenham ( $35.6^\circ$ ) indicate a duration of only 6 to 8 minutes. At San Fernando ( $85.25^\circ$ ) a Milne pendulum gives a duration of 45 minutes; at Krakau ( $85.98^\circ$ ) a Bosch-Omori, subject to some solid friction, gives 5 minutes; and at Vienna ( $86.37^\circ$ ) a Wiechert inverted pendulum gives 13 minutes. The following table, in which the duration of the principal part is given in minutes, is made up from the records of Milne pendulums alone, and shows that even the same type of instrument does not yield consistent results.

<sup>1</sup> Prof. C. F. Marvin (Monthly Weather Review, 1907, vol. xxxv, p. 5) obtained very interesting results regarding the direction of vibration at Washington at the time of the Jamaican earthquake, January 14, 1907. The longitudinal vibrations began earlier and were much the stronger during the preliminary tremors; the transverse vibrations were much the stronger during the principal part.

TABLE 6.—Duration of the Principal Part as Recorded by Milne Instruments.

STATION.	DISTANCE.	DURATION.	STATION.	DISTANCE.	DURATION.
Victoria . . .	10.4	49	Kew. . . . .	77.6	25 or 36
Toronto . . .	32.9	32	Irkutsk . . . . .	80.8	28 or 60
Honolulu . . .	34.6	62	Coimbra . . . . .	81.4	24
Baltimore . . .	35.7	47	San Fernando. . . . .	85.3	54
Paisley . . .	72.6	29	Calcutta . . . . .	112.7	31
Edinburgh . . .	73.0	35	Bombay . . . . .	121.2	26
Bidston . . .	74.8	36	Perth . . . . .	132.4	60

It is quite evident that no conclusion regarding the variation in duration of the principal part at different distances from the origin can be drawn from such data.

But, altho we may be unable to recognize a progressive change in the duration of the principal part, nevertheless it is quite certain that all seismographs register a strong motion lasting much longer than the original shock. What has been called the *violent shock*, and which alone could have affected distant seismographs, did not last more than 40 or 50 seconds; whereas the recorded principal part certainly lasted many minutes and in some cases an hour. This may be in part due to the synchronism of the periods of the waves and the instruments, but it can not be entirely explained in this way and it must be lookt upon as not yet understood.

We have a little information regarding the prevalent direction of motion during the principal part. At Ottawa, Cheltenham, and Albany the longitudinal waves retained their intensity for a longer time than the transverse, tho we can not say which attained the greater maximum. At Rocca di Papa the longitudinal waves attained the greater maximum, but the durations of the two were about the same. At Messina the longitudinal waves were stronger and lasted longer than the transverse. On the other hand, the transverse waves lasted longer at Florence, and they had a greater maximum at Cagliano. The observations are very meager and very inconsistent; evidently more careful observations must be made to show to what extent the longitudinal and transverse waves are characteristic of different parts of the seismogram, how far this quality is different at different stations, to what variations it is subject, and what are their causes.

The long tail portion of the seismogram is still a riddle; and altho we can hardly help considering it as in some way due to waves following different paths and to reflections, we shall see further on (page 124) that simple reflections will not explain it. One may easily be misled in attempting to correlate certain movements on different seismograms; for instance, the last marked broadening of the trace of the Paisley, Edinburgh, and Bidston seismograms (sheet No. 1), occurring a few minutes before 14<sup>h</sup> 30<sup>m</sup>, is so similar that one would naturally suppose that they represent a special group of progressive waves; on determining the times of occurrence we find for its maximum, 14<sup>h</sup> 14.7<sup>m</sup>, 14<sup>h</sup> 20<sup>m</sup> and 14<sup>h</sup> 26.1<sup>m</sup> at the three stations respectively; the difference in time at Paisley and Bidston is 11.7 minutes and the difference in distance 252 km.; therefore the velocity of propagation would be 22 km./min. But the time for them to reach Paisley from the focus, a distance of 8,060 km. would be 62.2 minutes, requiring a velocity of 130 km./min. These values are so different that we must regard this broadening of the trace as due to some accidental synchronism of periods at the three stations, and not to an objective characteristic of the disturbance itself. There are many difficulties in understanding the characteristics of the seismogram which have not been overcome; and it is not likely that we shall have a complete explanation of it until a large number of heavily damped seismographs are installed, whose records will correspond closely with the actual movements of the earth, and will not be materially affected by the peculiarities of the instrument itself.



THE PROPAGATION OF THE DISTURBANCE.

THE HODOGRAPHS

All the available data which has been obtained bearing on the velocity of transmission has been collected in table 7 and exhibited graphically in plate 2. It will be seen that by far the larger number of observations occurred at distances between 70° and 100° from the origin. Many of the stations are at so nearly equal distances that they have been grouped together and entered as a single observation in the plate; therefore the number of observations marked on the plate is considerably less than the number actually represented. All the seismograms have not the same degree of accuracy, and different symbols have been used to indicate these differences; the observations from some stations are less reliable on account of the difficulty in reading the seismogram; in some cases, less confidence can be given to the record because the seismogram was not at hand to confirm it; this applies with special force to the observations of the regular waves, for there is no general consensus of opinion as to the particular point of the seismogram that indicates their beginning. The curves drawn in the plate show the times taken for the three phases to travel from the origin to the distance of the observing station, these distances being indicated in degrees and kilometers. The stations are marked at the bottom, singly or in groups; occasionally some stations of a group fail to yield satisfactory determinations of the time of arrival of a phase of the disturbance; this phase is then marked with the initials of the stations which recorded it.

TABLE 7.—Times of Transmission of the Various Phases.  
 [1 P. T. = First preliminary tremors.] [2 P. T. = Second preliminary tremors.]  
 [R. W. = Regular-waves.] [3 P. = Principal part.]

STATION.	ARC.		CHORD.	TIME INTERVAL, IN MINUTES AND SECONDS.			
				1P. T.	2P. T.	R. W.	P. P.
				m. #.	m. s.	m. s.	m. s.
Mount Hamilton	1.16	128	129	0 17	0	....	....
Victoria	10.41	1157	1156	0 14	... m	....	....
Sitka	20.72	2303	2291	4 34	8 38	10 04	....
Tacubaya	27.70	3081	3050	5 30	10 24	13 09	13 37
Toronto	32.93	3571	3610	6 48	12 00	15 24	....
Honolulu	34.60	3846	3790	7 00	11 54?	....	....
Ottawa	35.38	3932	3871	6 51	12 2?	....	18 30
Washington	35.44	3939	3878	6 52	12 32	16 52	18 00
Cheltenham	35.64	3962	3899	6 55	12 37	17 48	20 00
Baltimore	35.74	3973	3909	6 54	12 42	....	19 06
Average	35.55	3952	3889	6 53	12 33	17 20	18 54
Albany	37.13	4128	4056	9 02	16 04	20 17	21 12
Porto Rico	53.45	5942	5729	9 22	17 39	....	....
Trinidad	60.94	6774	6460	....	....	29 30	....
Apia	69.20	7694	7235	10 54	19 56	....	....
Mizusawa	70.46	7834	7349	11 39	20 46	....	....
Ponta Delgada	72.53	8064	7536	11 00	....	....	38 00
Paisley	72.54	8065	7537	10 42	20 48	34 54	38 30
Bergen	72.79	8092	7560	10 23	19 47	....	39 16
Edinburgh	72.99	8115	7578	11 00	20 30	35 30	39 30
Average	72.71	8079	7553	10 48	20 22	35 12	38 48
Tokyo	73.92	8217	7660	12 07	21 56	33 52	37 47
Bidston	74.81	8317	7739	11 48	21 30	35 42	39 06
Average	74.37	8267	7700	11 58	21 43	34 47	38 28
Upsala	76.80	8538	7914	12 23	22 16	37 52	40 34
Shide	77.08	8569	7938	11 48	21 44	38 08	....
Osaka	77.30	8594	7957	11 56	21 45	35 28	....
Kobe	77.54	8619	7976	11 55	21 51	37 52	....
Kew.	77.63	8610	7986	....	21 30	37 30	....
Average	77.27	8540	7954	12 00	21 49	37 22	....

TABLE 7.—Times of Transmission of the Various Phases.—Continued.

STATION.	ARC.		CHORD.	TIME INTERVAL, IN MINUTES AND SECONDS.			
				IP. T.	2P. T.	R. W.	P. P.
				m. s.	m. s.	m. s.	m. s.
Hamburg	79.74	8866	8167	12 04	22 22	39 17	....
Uccle	79.80	8872	8173	11 59	22 29	....	....
Jurjew	80.27	8924	8212	12 15	22 18	....	....
Irkutsk	80.82	8986	8259	12 08	22 22	38 48	....
Average	80.16	8912	8203	12 06	22 23	39 02	....
Potsdam	81.35	9042	8303	12 22	22 55	39 21	42 22
Göttingen	81.36	9046	8304	12 16	22 38	38 37	44 08
Coimbra	81.39	9049	8307	12 54	22 30	38 00	....
Average	81.37	9046	8305	12 31	22 47	38 39	43 15
Leipzig	82.40	9161	8392	12 22	23 11	38 53	43 02
Jena	82.45	9167	8396	12 06	22 41	38 44	44 11
Strassburg	82.91	9218	8434	12 29	22 52	....	....
Average	82.59	9182	8407	12 19	22 55	38 48	43 36
Munich	84.75	9423	8587	12 32	23 06	39 15	....
San Fernando	85.25	9478	8628	12 36	22 48	....	....
Average	85.00	9451	8541	12 34	22 57	39 15	....
Tortosa	85.65	9522	8660	12 27	23 32	42 32	....
Kremsmünster	85.77	9535	8670	11 54	23 00	....	....
Krakau	85.98	9558	8687	....	23 14	41" 38	45 07
Granada	86.08	9570	8696	12 12	22 52	42 11	....
Pavia	86.20	9583	8707	12 28	22 38	41 32	48 27
Vienna	86.37	9602	8719	12 47	23 40	41 18	45 05
Average	86.01	9562	8690	12 18	23 09	41 50	....
Laibaeh	87.22	9697	8786	13 06	23 02	41 42	....
Triest	87.74	9754	8828	12 41	23 08	....	....
O'Gyalla	88.08	9792	8856	12 52	23 40	....	....
Florence (Ximeniano)	88.23	9808	8868	13 57	24 36	....	....
Zagreb	88.33	9820	8876	12 57	23 03	40 48	....
Pola	88.34	9821	8877	13 28	23 45	41 46	....
Quarto-Castello	88.40	9828	8882	14 10	24 36	39 33	....
Zi-ka-wei	88.49	9838	8889	12 56	23 08	43 32	....
Pilar	88.75	9866	8909	13 06	....	....	....
Average	88.17	9803	8864	13 17	23 37	40 57?	....
Rocca di Papa	90.48	10061	9046	....	24 02	45 02	....
Belgrade	90.67	10080	9061	....	24 26	....	....
Average	90.58	10070	9054	....	24 14	45 02	....
fsehia	91.84	10210	9152	14 14	24 30	43 56	....
Caggiano	92.63	10297	9213	....	24 12	44 18	....
Taihoku	92.75	10311	9222	16 24?	..	43 52	....
Sofia	93.58	10404	9286	12 32?	23 " 17?	44 38	....
Messina	94.67	10524	9368	....	..	43 00?	....
Catania	95.04	10567	9396	13' 37	23 " 57?	44 38	53 20?
Wellington	97.62	10853	9588	14 06	24 18	49 42?	....
Calamate	98.28	10927	9636	....	....	49 38	....
Tiflis	99.43	11054	9719	13 41	25 31	....	....
Taschkent	99.86	11102	9750	14 00	24 54	....	....
Average	99.65	11165	9735	13" 50?	24 12?	....	....
Christchurch	100.40	11162	9790	....	21 06	48 30	....
Manila	100.46	11189	9793	10 16?	....	48 30?	....
Average	100.43	11165	9790	10 16?	21 " 00"	48 30?	....
Tadoteu	100.00	11262	9852	12 39?	....	....	....
Cairo	107.92	11998	10302	18 30	26 30?	....	....
Calcutta	112.72	12531	10607	16 42?	20 54	53 06	....
Bombay	121.19	13472	11099	....	28 18	59 18	....
Katavia	124.99	13897	11300	26' 26?	29 48	61 54	....
Kodaikanal	127.90	14226	11449	19 00?	....	....	....
Perth	132.37	14716	11655	....	25 06?	65 48	....
Cape of Good Hope	148.63	16524	12256	24 00?	....	81 00?	....
Mauritius	102.02	18012	12601	....	28' 42?	83 48	....

After plotting in the times of arrival of the three phases at the various stations a smooth curve is drawn thru the points marked, so that the errors of the observations may be as small as possible; the velocity of the first preliminary tremors, as noted on page 7, is assumed to be 7.2 km./sec. near the origin; the velocity of the second preliminary tremors in the same region becomes 4.8 km./sec. from the Mount Hamilton observations, as they begin there 9 seconds after the first preliminary tremors. A special method was followed in drawing the straight line for the long waves and it will be given further on. These curves are called "hodographs." The average velocity of transmission to any station is evidently given by the time interval divided by the distance; that is, it would equal the tangent of the angle which a straight line, drawn from the origin to a point on the hodograph immediately above the station, makes with the vertical; and the velocity along the surface would be given by the difference between the times of arrival at two stations divided by the difference of their distances from the origin, provided these distances differed but little from each other.

#### THE PRELIMINARY TREMORS.

The first thing that strikes us on examining the plate is that the hodographs of the first two phases are curved, indicating that the average velocity of transmission increases with the distance; and that the hodograph of the regular waves is straight, showing a constant velocity independent of the distance. These distances have been measured along the surface, or, as it is expressed, along the arc. When we plot the hodographs of the first two phases in terms of the distance of the stations from the origin, measured by the shortest route, that is, by the chord, as shown in the upper part of the plate, we find them still curved, but much less so than in the former case. It is the general belief that the curvature of these lines indicates that the waves travel thru the body of the earth and that their velocity increases with the depth of the path below the surface; if this be true, and no satisfactory arguments have been advanced against it, the waves would not follow the shortest path to a station, that is the chord, but would follow a curved path, convex downward, which would bring them to the station in the shortest time. Unfortunately at distances greater than  $100^\circ$  for the first preliminary tremors and  $125^\circ$  for the second preliminary tremors, the observations of the phases become extremely doubtful; and it is precisely the paths leading to stations beyond these distances that dip very deep towards the center of the earth, and that might reveal the nature of that region.

The cause of the inaccuracy of observations at great distances is not far to seek. The first preliminary tremors are always very weak and are recorded as very small vibrations even at comparatively small distances. If, moreover, as we have given reasons to believe, their vibrations are longitudinal, a large part of their energy would be taken up in vertical vibrations at the surface, particularly at great distances, and would therefore fail to produce an appreciable disturbance of instruments recording horizontal movements only. The horizontal and vertical components of the first preliminary tremors at Göttingen (distant  $81.36^\circ$ ) have about the same amplitude, which is very small; and this shows that the weakness of this phase is not merely due to its tendency to produce vertical vibrations at the earth's surface. Moreover, the amplitude of vibrations would decrease more rapidly than the distance, because, as Prof. C. G. Knott\* has shown, the curved paths of these waves would cause the energy to be concentrated upon the nearer stations, with a corresponding diminution at the more distant ones. It also happens that all the instruments at stations beyond  $100^\circ$  have a low magnifying power, with the exception of Batavia; and even then; the magnifying power, 05.5, may be insufficient to indicate the real beginning of the first preliminary tremors. It is quite possible that the beginning of the record at Mauritius may represent the second preliminary tremors, and that the

\* The Physics of Earthquake Phenomena, p. 253.

hodograph should pass exactly thru the records of Calcutta and Mauritius; but this is too uncertain to justify the extension of the hodograph to Mauritius. It does not seem to be possible, from the observations of this earthquake, to draw any certain inference regarding the velocity of propagation of the first two phases much beyond  $110^\circ$ .

The beginning of the second preliminary tremors is often the most easily recognizable point of the seismogram. The first preliminary tremors frequently have so small an amplitude that their beginning can not be determined; and sometimes there is no evidence of any movement until the second preliminary tremors arrive. The latter usually show themselves by a definite and well-marked increase in the amplitude of the recording instrument.

The records of the Kingston earthquake of January 14, 1907, offer a very instructive example of the influence of the magnifying power of seismographs on the times recorded. Washington, with a magnifying power of 25, recorded the first preliminary tremors; Cheltenham, with a magnifying power of 10, began its record with the second preliminary tremors; whereas Baltimore, with a magnifying power of 6, only recorded the principal part. These three stations are close together and practically at the same distance from Kingston.

The hodograph of the second preliminary tremors, expressed in terms of the distance measured along the chord, shows a point of inflection at a distance of about 9,000 km.; this does not indicate that the average velocity diminishes at this distance, but merely that it does not increase as rapidly as it does at shorter distances; this part of the curve, however, is quite doubtful and we are not justified in drawing any very definite conclusion from its form. It is extremely disappointing that the observations of this earthquake do not lead to definite results regarding the propagation of the disturbance to very great distances; for the point where the earthquake occurred and the time of its occurrences are both known to a satisfactory degree of accuracy<sup>1</sup> and instruments recorded the shock at stations as far as  $162^\circ$  distant, that is, very nearly to the antipodes. This further emphasizes the importance of installing instruments recording the vertical component of motion, and instruments with high magnifying powers, not less than 100; for they alone can be expected to yield satisfactory records of the times of the arrival of the various phases of very distant earthquakes, regarding which our information is still very vague.

As the earthquake originated at some distance below the surface, the surface velocity in the immediate neighborhood of the epicentrum would be very large; it would diminish rapidly as the distance increased, would reach a minimum and again increase as the paths of the waves to the more distant stations extended deeper into the earth. If we had absolutely accurate observations, the hodograph, drawn from them, would be concave upwards near the origin, would pass thru a point of inflection a little further off, and would then pass into the general form, concave downwards, as drawn in the plate. Seebach<sup>2</sup> first pointed out that the form of the curve in the neighborhood of the origin could be used to determine the depth of the focus; he assumed constant velocity in all upward directions near the origin; Prof. A. Schmidt,<sup>3</sup> assuming increasing velocity with the depth, modified the results; but the degree of accuracy required of the observations is so great that all attempts so far made to determine the depth of the focus by this means are unreliable; and we can not expect to apply the method successfully until the accuracy of our observations is far greater than it is now. Table 8 shows the distances of stations from the centrum in kilometers, in terms of their distances from the epicentrum measured along the surface of the earth, and of the depth of the centrum; these distances take into account the curvature of the earth and are accurate to a fraction of a kilometer.

<sup>1</sup> Das Mitteldeutsche Erdbeben von 6 Mars 1872. Leipzig, 1873.

<sup>3</sup> Wölbewegung und Erdbeben. Jahreshefte für Vaterlands Naturkunde in Württemberg, 1888, p. 248.



Table 9 shows the differences in the time of arrival in seconds, of the first preliminary tremors at stations at various distances, when the focus is at the given depth or at the surface, calculated under the supposition that the velocity is 7.2 km./sec. Table 10 gives similar results for the second preliminary tremors, whose velocity is taken at 4.8 km./sec. (see p. 117). In these tables  $z$  is the depth of the focus and  $D$  the distance of the station from the epicentrum measured along the earth's surface, in kilometers.

TABLE 8. — Distances from the Centrum (in kilometers).

$D$ $z$	10	20	50	100	200	400
0	10.0	20.0	50.0	100.0	200.0	400.0
10	14.1	22.3	51.0	100.5	200.2	399.8
20	22.3	28.3	53.8	101.9	200.8	399.9
50	51.0	53.8	70.6	111.5	205.5	401.5
100	100.5	101.9	111.6	141.3	222.3	409.3

TABLE 9. — Differences between the Times of Arrival of the First Preliminary Tremors when the Focus is at the Surface or at the Depth  $z$  (in seconds).

$D$ $z$	10	20	50	100	200	400
10	0.6	0.2	0.1	0.0	0.0	0.0
20	1.6	1.2	0.5	0.3	0.1	0.0
50	5.7	4.7	2.9	1.6	0.8	0.2
100	12.6	11.4	8.6	5.7	3.1	1.3

TABLE 10. — Differences between the Times of Arrival of the Second Preliminary Tremors when the Focus is at the Surface or at Depth  $z$  (in seconds).

$D$ $z$	10	20	50	100	200	400
10	0.9	0.5	0.2	0.0	0.0	0.0
20	2.6	1.7	0.8	0.4	0.2	0.0
50	8.5	7.0	4.3	2.4	1.1	0.3
100	18.9	17.0	12.8	8.6	4.6	1.9

A glance at these tables will show that, for any probable depth of focus, stations at a distance from the origin of two or three times this depth would be wholly incapable of supplying time records which could be used in determining the depth. Let us take an example. Suppose the focus of an earthquake was at a depth of 50 km., and that it was recorded at two stations, one 50 km. and the second 100 km. distant from the epicenter; the first would record it 2.9 seconds and the second 1.6 seconds later than if the earthquake had occurred at the same time at the surface. The difference of these numbers, namely, 1.3 seconds, is the difference in the interval between the recorded times at the two stations, for earthquakes at a depth of 50 km. and at the surface. It would be quite impossible to determine so small a difference with any instruments now in use, and therefore such observations could only tell us that the depth was probably not much greater than 50 km. But an accurate record at a station, say, 200 km. distant from the origin might be used in connection with the records of nearer stations, to show that the focus was not very deep. In our determination of the location of the focus of the California earthquake we had observations of four stations, and by the method of least squares we found its most probable location. The observations at Ukiah and Mount Hamilton had no practical influence in determining the depth, but helped to locate the epicenter; whereas the observations at the nearer stations determined the approximate depth.

The actual points of inflection of the hodographs are not so very near the epicenter, their distances being 252, 357, 463, and 796 km. for the depths of focus 10, 20, 50, and

100 km., respectively; but the curvature of the lines practically disappears at distances from the epicenter equal to twice the depth of the focus.

Professor Rizzo has made strong inflections in his hodograph of two Calabrian earthquakes.<sup>1</sup> A straight line would fit the observations of the first preliminary tremors in the first earthquake to distances of 2,000 km. rather better than his curves, especially for the near stations; and the observations which bend the hodograph of the first preliminary tremors in the second earthquake are far too inaccurate to justify the curve. The observations of the second preliminary tremors in both cases are too few to be decisive. Moreover, the points of inflections of the curves are at a distance of about 800 km., which would correspond to a depth of focus of about 100 km.; whereas Professor Rizzo does not think the depth in either case greater than 50 km.

The curvature of the hodographs near the origin has not been shown in plate 2 because the scale is too small. The times given by the curves are measured from the time the earthquake occurred, as nearly as this could be determined, and not from the time the disturbance reached the surface at the epicenter, as has usually been done. There are certain objections to the usual method; the disturbance does not pass from the focus directly to the surface and then along the surface to distant points, but it goes directly to the distant points, and its time of arrival there, even at such short distances as four times the depth of the focus, is not materially affected by this depth, tho the time of arrival at the surface is. It is better, therefore, for our base-line to represent the time of occurrence of the shock at the focus; and if the scale of the drawing is sufficiently large to show the upward curvature of the hodograph, the curve would not pass thru the origin but above it, at a distance representing the time necessary for the shock to go from the focus to the surface. This will be only a few seconds; perhaps never more than 7 seconds for the first preliminary tremors and 10 seconds for the second preliminary tremors, as these intervals would correspond to a depth of focus of 50 km.

In table 11 are shown the velocities of the first preliminary tremors and second preliminary tremors in kilometers per second, measured along the chord. The velocities are not calculated from actual observations at the stations, but from the hodographs.

TABLE 11.—*Velocities of First and Second Preliminary Tremors in Kilometers per Second along the Chord.*

DISTANCE.			FIRST PRELIMINARY TREMORS.		SECOND PRELIMINARY TREMORS.	
Degrees.	Arc.	Chord.	Interval.	Velocity, chord.	Interval.	Velocity, chord.
°	km.	km.	min.		min.	
0	0	0	0.0	7.2	0.0	4.8
10	1112	1110	2.4	7.7	3.85	4.8
20	2224	2212	4.3	8.6	7.6	4.9
30	3335	3297	6.1	9.0	10.9	5.0
40	4447	4357	7.7	9.4	13.8	5.3
50	5559	5384	9.0	10.0	16.3	5.5
60	6671	6370	10.2	10.4	18.6	5.7
70	7783	7307	11.35	10.7	20.6	5.9
80	8894	8189	12.3	11.1	22.25	6.1
90	10006	9009	13.25	11.3	24.0	6.2
100	11118	9759	14.2	11.4	(25.7	6.3
					125.4	6.4
110	12230	10436	14.9	11.7	j 27.2?	6.4?
					126.5?	6.6?
120	13342	11033	....	....	128.5?	6.5?
					127.3?	6.7?
130	14453	11546	....	....	f 29.8?	6.5?
					l 27.8?	6.9?

<sup>1</sup> Sulla Velocity di Propagazione della Onde Sismiche, Acad. R. d. Scienze di Torino, 1905-06, vol. Lvir, pp. 309-350; Nuovo Contributo allo Studio della Propagazione dei Movimenti Sismici, same, 1907-08, vol. LIX, pp. 375-419.

Two sets of values of the second preliminary tremors are given for distances of  $100^\circ$  or more; they correspond to the two curves drawn in plate 2. The first set are more in accord with the observation at Batavia, the second with that at Mauritius; but both are very doubtful beyond about  $110^\circ$ , where they do not differ much.

## THE PATHS OF THE WAVES THRU THE EARTH.

The velocities given show the average values between the focus and the distance indicated; but they do not show the actual velocity at any point of the path. The average velocity increases with the distance of the station; and this must be due to

increasing velocity with greater depth below the surface. With such increasing velocities it is impossible for the rays to follow straight lines, but they must follow paths which are concave upwards. Prof. E. Wiechert<sup>1</sup> has given a method for following out the paths of the waves, which is dependent upon the direction of the wave as it approaches a station. The angle at the station between this direction and the surface is the angle of emergence,  $e$ , and its complement is the angle of incidence,  $i$  (see fig. 27). This angle may be found immediately if we know the velocity of the wave near the surface and the surface velocity. The former is about 7.2 km./sec.; the latter can be determined from the hodograph; it equals the angle made with the vertical by the tangent line to the hodograph. The value of the surface velocity depends, therefore, upon the actual direction of the hodograph line (plate 2), and can only be determined accurately provided the

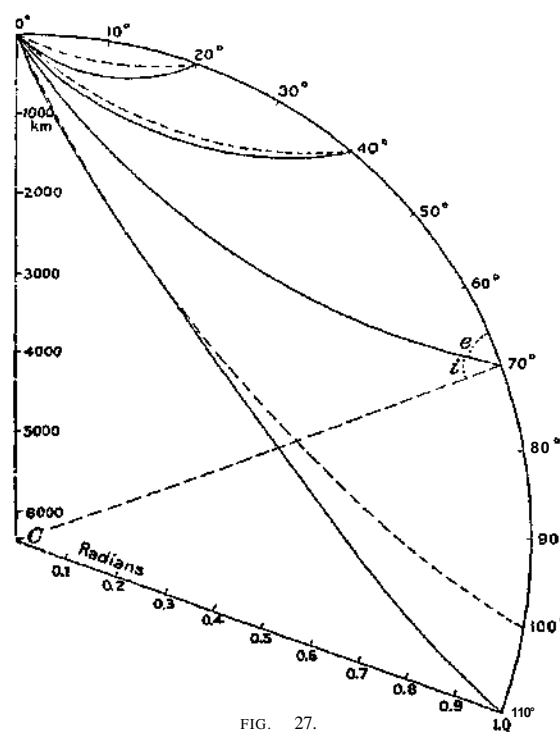

FIG. 27.

hodograph is accurate. This, however, is by no means true, so that our values for the surface velocity are only approximately correct. The paths of the waves depend upon the angles of emergence, and as they are only approximate the same is true of the paths. They, however, represent fairly well the course of the waves as they travel thru the earth to stations at various distances. Following Professor Wiechert's method these paths have been drawn in fig. 27, the full lines representing the first preliminary tremors and the broken lines the second preliminary tremors. The paths have been drawn for the first preliminary tremors leading to distances up to  $110^\circ$  and for the second preliminary tremors to  $100^\circ$ ; these are the limiting distances to which our hodographs yield fairly good values.

It will be seen that the paths have a very marked curvature, especially those leading to stations which are not very distant. The paths leading to points less than  $70^\circ$  distant are less curved for the second preliminary tremors than for the first preliminary tremors; but the opposite is true for paths leading to greater distances. The paths of both groups leading to this particular distance are practically coincident. As the waves penetrate deeper into the earth their paths become less curved; and the path leading to the antijvodes thru the earth's center would be a straight line.

<sup>1</sup> tidier Erdbebenwden. Nach. d. K. Gesells. d. Wissens. zu Göttingen, Math.-phys. Kl., 1907.

## RELATION OF THE VELOCITY TO THE DEPTH BELOW THE EARTH'S SURFACE.

Professor Wiechert's method enables us to determine the velocities at different depths below the surface. For any point on a given path we have

$$\frac{r \sin i}{v} = \frac{\bar{r} \sin \bar{i}}{\bar{v}}$$

where  $r$  is the distance from the center of the earth,  $i$  the angle which the path makes with the radius, and  $v$  the velocity; the letters in the second member refer to the same quantities at the point where the path comes to the surface.

TABLE 12.—Surface Velocities and Angles of Emergence.

FIRST PRELIMINARY TREMORS.			SECOND PRELIMINARY TREMORS.		
Distance.	Surface velocity.	$e$	Distance.	Surface velocity.	$e$
	Km. sec.	° /		Km. sec.	° /
0	3.9	0 00	0	2.6	0 00
20	5.5	44 51	20	2.95	28 06
40	6.9	55 19	40	3.75	46 22
70	9.4	65 46	70	5.45	61 42
110	13.1	72 40	100	7.5	69 51

In table 12 we have collected together the values for the surface velocities and for the angle of emergence  $e$ , for points at several distances from the origin; and from these data we can calculate the velocity at the points where the respective waves reach their greatest

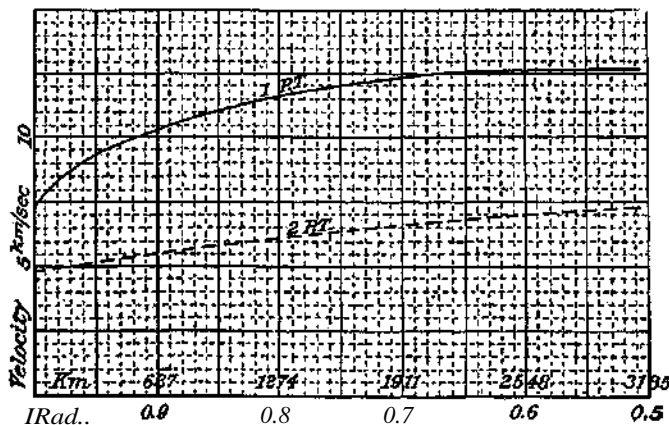

FIG. 28.

depths. At these points the paths are at right angles to the radius and  $\sin i$  is 1. The value of  $r$  can be measured in fig. 27 and the value of  $v$  determined. This process was carried out and the values of  $v$  given in table 13 were found. These values were plotted on section paper and a smooth curve drawn thru them representing the velocity as a function of the depth. On applying these velocities to the various parts of each path it was found that the time the wave would take to traverse the path did not correspond exactly with the time given by the hodograph. The velocities were slightly altered and, by the method of trial and error, new values were found which would make the time intervals correspond to those given by the hodographs. The changes in the velocities were small. These velocities are shown in table 13 in the column headed  $u$ , and graphically in fig. 28. The velocity increases with the depth below the surface, but more and more slowly as the depth becomes greater. There is no indication of a sudden change in the velocity, such as we should expect if there were any sudden changes in the nature of the earth's interior, but it must be remembered that the greatest depth reached by the deepest path we have drawn is only about halfway to the earth's center, and that our values, especially for the deeper paths, leave much to be desired in accuracy; indeed, the

TABLE 13.— *Velocities of Earthquake Waves at Various Depths below the Earth's Surface.*

DISTANCE BETWEEN ENDS OF PATH.	DISTANCE FROM EARTH'S CENTER, RADIAN.	DEPTH BELOW SURFACE, (km.)	FIRST PRELIMINARY TREMORS.		SECOND PRELIMINARY TREMORS.	
			<i>v</i>	<i>u</i>	<i>v</i>	<i>u</i>
0	1	0	7.2	7.2	4.8	4.8
20	f 0.93 10.955	435 280	9.4	9.75	...	...
40	/ 0.845 1 0.862	980 870	10.7	11.1	5.2'	5.25"
70	f 0.693 10.693	1960 1960	12.6	12.4	6.6'	6.65"
100	0.524	3020	...	...	7.3	7.2
110	0.512	3150	12.25	12.7'	...	...

results we have reached can only be looked upon as fair approximations to the truth; and we need more numerous and more accurate determinations of the times of transmission of earthquake waves, especially to great distances, before we can reach a satisfactory knowledge of the velocity of propagation at various depths.

## INTERNAL REFLECTIONS.

When the waves of the first two phases come to the surface of the earth they are reflected, and as the density of the air is insignificant in comparison with that of the rock, practically none of the energy escapes into the air. But the reflected energy will be divided between two waves, a longitudinal and a transverse, each of which, therefore, will be weaker than the original waves.<sup>1</sup> Waves will reach a given station, *S* (fig. 29), after a single reflection, from three points on the arc between the focus and the station. The first is the half-way point *B*; from this point an incident longitudinal wave will send a reflected longitudinal wave and an incident transverse wave will send a reflected transverse wave to the station. The second is the point *C*, where the reflected transverse waves, due to incident longitudinal waves, pass off in the proper direction at an angle of reflection smaller than the angle of incidence, because their velocity is less than that of the longitudinal. The third point is *D*, where the transverse waves are transformed into longitudinal waves, which pass on to *S*. There would also be three analogous points *B'*, *C'*, *D'*, on the major arc. When we consider waves which reach *S* after two reflections, we see that they may follow many different paths, as they transform by reflection from one type of wave to the other; there are of course two points, situated at one-third and two-thirds the distance to the station, where reflections can take place

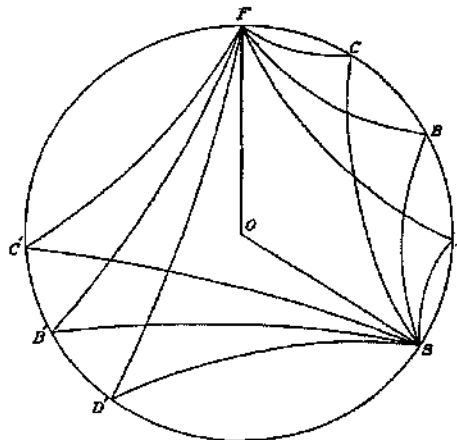

FIG. 29.

<sup>1</sup> The reflection and refraction of waves in elastic media was first thoroly elucidated by Prof. C. G. Knott, "Earthquakes and Earthquake Sounds," Trans. Seismol. Soc. Japan, 1888, vol. xn, pp. 115-136; "Reflection and Refraction of Elastic Waves, with Seismological Applications," Phil. Mag., 1899, vol. XLvii, pp. 64-97, 567-569. He has also given a very interesting account of the subject in his recently published work, "The Physics of Earthquake Phenomena." Prof. E. Wiechert has also discuss this subject ("Ueber Erdbebeiawellen," Nach. d. K. Gesells. d. Wissen. zu Göttingen, Math.-phys. EL, 1907).

without change of type, and the reflected waves will reach *S*; similarly the distance may be divided up into any number of equal lengths, and waves can be reflected successively at all these points without change of type, and reach *S*. It would be very complicated to follow the course of waves of changing type, but the times of arrival at *S* of waves of unchanging type can easily be found. The interval for a singly reflected wave would be twice the interval required to go half the distance, and this interval can immediately be taken from the hodograph. The interval for a wave which has suffered two reflections will be three times the interval required to go one-third the distance, and so on. These reflected waves are probably the most important cause of the variations of intensity during the early phases. The first preliminary tremors are always weak, but the addition of the waves after one reflection to the direct waves may make the latter evident, when without them they would not be. This seems the case at Cairo, Batavia, and the Cape of Good Hope. The times of beginning at these observatories, as given by their directors, are within a half minute of the times at which longitudinal waves would reach them after one reflection.

At the following stations the effects of the longitudinal waves after one reflection can be detected at an interval after the beginning which is given in minutes, these being the proper intervals as determined from the hodograph: Tacubaya, 0.5 minute; stations in Great Britain, 2.5 to 3 minutes; Upsala, slight, 2.5 minutes; Jena, 3 minutes; Munich, slight, 3 minutes; Göttingen, due in 2.5 minutes; slight effect in 3 minutes. The smallness of the effects in all these cases, and the fact that the waves are weakened on reflection by having a portion of their energy transformed into waves of the other type, make it improbable that the effect of longitudinal waves after two or more reflections is at all noticeable at very distant stations.

Horizontal transverse vibrations would suffer no transformation, and as they would practically lose no energy by refraction into the air, their amplitudes would diminish much more slowly than those of the longitudinal waves; they should tend, therefore, to cause marked variations in the intensity of the seismogram, the vibrations being transverse to the direction of propagation. Vertical transverse vibrations would suffer transformation like longitudinal waves, provided the angle of incidence were sufficiently small; if, however, the sine of the angle of incidence becomes greater than two-thirds the ratio of the velocities of the transverse to the longitudinal waves, that is, if the angle becomes greater than about  $42^\circ$ , there will be no transformation, and the transverse waves will be totally reflected as transverse waves. It is quite clear, therefore, that they will preserve their intensity far better than the longitudinal waves, and indeed will get energy from the latter.

When we look for the reflected second preliminary tremors on the seismogram, we are disappointed that they are not more marked, but nevertheless evidences of them can be found on many seismograms. For instance, at Tacubaya the waves reflected once and twice coalesce and appear about one minute after the beginning of the second preliminary tremors; the waves reflected once arrive at stations in Great Britain and in Japan from 4 to 5 minutes after the second preliminary tremors, and those reflected twice in about 6 or 7 minutes; the latter are not evident on the Japanese seismograms. At Bombay the two waves reflected once and twice appear after 9 and 13 minutes; at Batavia they are due after 8.5 and 13 minutes; indications of them are found after 8.5 and between 11.5 and 14 minutes; and many other stations could be cited. It is not entirely beyond question that the strengthenings of the seismograms are due to the reflected waves, both in the case of the first preliminary tremors and the second preliminary tremors; but they occur at the times indicated by the hodograph, and it seems most probable that we have interpreted them correctly.

There is one group of reflected transverse waves which have especial interest, namely, those whose angle of incidence is so large that they experience innumerable reflections, that is, they practically creep around the earth's surface. Professor Knott has suggested that they are the so-called surface waves.<sup>1</sup> But there are certain obvious objections to this idea. They are, that the speed of propagation could not be less than the speed of the transverse waves near the surface of the earth; this speed appears to be about 4.8 km./sec, considerably greater than that of the long waves; again, the energy in the surface waves is much greater than in the second preliminary tremors, but possibly the distribution of energy on account of the change of velocity, with the depth below the surface and the retention of energy by the transverse waves creeping along under the surface, may account for this; lastly, observations do not show consistently that the surface waves are made up in large proportion of transverse waves (see page 114). But, nevertheless, Professor Knott's suggestion is a very interesting one, and it is quite possible that these objections may be overcome when we have more accurate knowledge of the various quantities concerned.

It is difficult to find the time of arrival of waves reflected once in the major arc. The minor arc must be greater than  $120^\circ$  for half the major arc to be less than this value, which is the limit to which the hodograph can be relied upon. The first preliminary tremors, after reflection in the major arc, are apparently too weak to be evident on the seismogram. It would take about 55 minutes for the transverse waves, reflected once on the major arc, to reach stations beyond  $120^\circ$  from the origin; that is, they would reach them at about  $14^{\text{h}} 07^{\text{m}}$ ; at Bombay the motion becomes most irregular at this time; at Batavia there are variations of intensity, but nothing very definite; at Kodaikanal and at Perth the seismograms are stronger at about this time. Altho we can not give the exact time at which reflections on the major arc would reach stations at a less distance than  $120^\circ$  from the origin, the hodographs show that they could not possibly be earlier than the arrival of the regular waves, and, therefore, they are completely masked by the much stronger disturbance existing during the regular waves, the principal part, and the earlier parts of the tail.

#### THE SURFACE WAVES.

In addition to the times of arrival of the first two phases we have plotted in plate 2 the times of arrival of the regular waves. The surface waves are spread over many minutes on the seismogram, but as already noted, we have taken as the beginning of the regular waves that point where the irregular movement (which is a part of, or follows, the second preliminary tremors) becomes regular, with a long period (30 to 50 seconds). The plotted positions of these times of arrival lie very closely along a straight line and no other simple curve could be drawn which would fit the observations materially better. To determine the best straight line to use we resort to the method of least squares, but as the observations differ very much in their reliability, each one is given a suitable weight. No elaborate distribution of the weights has been made. The observations which are considered good have received the weight 5, those which are fair 3, and those which are doubtful 1; a few observations which are very doubtful have been left out altogether. Where several stations have been grouped together the weight of the average is, of course, the sum of the weights of the individual stations. Those observations are considered doubtful which, on account of the absence of the seismogram, could not be checked, or in which the seismogram does not show clearly just where the regular waves begin. In table 14 we have collected the observations which have been used in determining the straight hodograph of the regular waves and their weights.

---

<sup>1</sup> The Physics of Earthquake Phenomena, p. 250.

TABLE 14.—Time Intervals and Weights of Observations for determining the Hodograph of the Regular Waves.

STATION.	DISTANCE.	TIME INTERVAL.	WEIGHT.	STATION.	DISTANCE.	TIME INTERVAL.	WEIGHT.
	°	min.			°	min.	
1. Sitka . . . . .	20.72	10.07	1	13. { Tortosa . . . . . Krakau . . . . . Granada . . . . . Pavia . . . . . Vienna . . . . . Laibach . . . . . Zagreb . . . . . Pola . . . . .	86.01	41.83	25
2. Tacubaya . . . . .	27.70	13.15	3				
3. Toronto . . . . .	32.93	15.40	3				
4. { Washington } *• { Cheltenham }	35.54	17.33	10				
5. Trinidad . . . . .	60.94	29.50	1	14. { Quarto-Cas- tello . . . . . Zi-ka-wei . . . . .	88.16	40.95	5
6. { Paisley } J. { Edinburgh }	72.76	35.20	10				
7. { Tokyo } Bidston . . . . .	74.37	34.78	6	15. Rocca di Papa . . . . . 16. Ischia . . . . . 17. Caggiano . . . . . 18. <del>Sofia</del> . . . . . 19. Catania . . . . .	90.48 91.84 92.63 93.58 95.04	45.03 43.93 44.30 44.63 43.93	1 1 3 1 3
8. { Upsala } Shide . . . . . Osaka . . . . . Kobe . . . . . Kew . . . . .	77.27	37.37	25				
9. { Hamburg } Irkutsk . . . . .	80.28	39.03	ft D				
10. { Potsdam } Gbttingen . . . . . Coimbra . . . . .	81.37	38.65	15				
11. { Leipzig } Jena . . . . .	82.43	38.80	10	20. Wellington . . . . . 21. Calamate . . . . . 22. { Christchurch } 23. { Manila . . . . . }	97.62 98.28 100.43	49.70 49.63 48.50	1 1 2
12. Munich . . . . .	84.75	39.25	5				
				25. Batavia . . . . .	124.99	61.90	5
				26. Perth . . . . .	132.37	65.80	5
				27. Cape of Good Hope	148.63	81.00	1

The observations used come from 47 stations, but they are only represented on the plate by 27 points, on account of the grouping together of stations at very nearly the same distance from the origin. The hodograph is determined from nearly twice as many stations as would be inferred from a cursory glance at the plate. We can not assume that the straight hodograph, determined from these observations, passes thru the origin; but we seek the position of a straight line in general which will best fit the observations.

The general equation of a straight line is  $y = mx - b$ . In this case  $y$  is the time of arrival of the long waves,  $x$  the distance of the station from the origin in degrees,  $m$  the reciprocal of the velocity of transmission, and  $b$  the point where the line cuts the axis of  $y$ ;  $-b/m$  is the point where it cuts the axis of  $x$ . On working out, by the method of least squares, the most probable values for  $m$  and  $b$  according to the weighted observations, we find

$$m = 0.494 \text{ min./deg.} \quad b = -0.91 \text{ min.} \quad \sqrt{m} = 2.03 \text{ deg./min.}$$

The velocity of the regular waves  $1/m$  is equal to 2.03 deg./min., or 3.75 km./sec.; and the point where the line crosses the axis of  $x$  is given by  $-b/m$ , which equals  $1.84^\circ$  or 205 km. These are the most probable values of the quantities concerned as deduced from the observations, but they are the result of a very limited number of observations and might be modified by results obtained in other earthquakes; and therefore we can not suppose that the constants are very accurately determined. On the other hand, the observations are in fair agreement with each other and therefore the results can not be very far wrong.

The fact that the straight line does not pass thru the origin, but crosses the axis of  $x$  at a distance of 205 km. from the origin does not mean that the regular waves start at this point at the time of the shock. Indeed, we have no observations at all along this part of the line, but there is a very simple explanation of the fact that the line does not pass thru the origin. This is that the regular waves are generated by one of the first two phases at the surface of the earth at a short distance from the origin. The point and



time at which the waves are brought into existence would be one of the two points where the hodograph of the regular waves crosses the hodographs of the first two phases. If the regular waves are started by the first preliminary tremors, this point would be at a distance of  $3.88^\circ$  or 431 km. from the origin; and the waves would begin there 1 minute after the shock occurred. If they were started by the second preliminary tremors they would originate at a distance of  $8.41^\circ$  or 935 km. from the origin and 3.25 minutes after the occurrence of the shock. It seems probable that the surface waves are due in a greater degree to the transverse than to the longitudinal waves, on account of their greater amplitude. As pointed out by Lord Rayleigh, the surface waves expand along the surface in two dimensions, whereas the other waves expand thru the body of the earth in three dimensions; the former, therefore, decrease in amplitude much more slowly than the latter and at distant stations cause a greater movement than the preliminary tremors which started them.

This would account for the preponderance of transverse motion in the principal part of the recorded disturbance, which has been observed in some cases. We must not infer, however, that there are no surface waves nearer the origin than the points we have designated; on the contrary, it is extremely probable that surface waves will be started at all parts of the surface within these distances when the earlier phases arrive there; but as the latter travel more rapidly than the former, new surface waves will be originated in front of them and will always lead them in their passage around the world. It seems probable that the regular waves are the leaders of the surface waves; hence their importance. If there are others which precede them, they are very irregular and their beginning does not produce a sufficiently definite point on the seismogram to be generally recognizable.

The straightness of the hodograph of the regular waves shows that the velocity of propagation is uniform along the arc, and therefore it is practically certain that the waves travel along the surface of the earth and we can apply our equation to determine the time of arrival at any point on the surface when we know its distance from the origin. We thus find 88 minutes as the time necessary to travel  $180^\circ$  to the antipodes.

## PROPAGATION ALONG THE MAJOR ARC.

We could find, from the equation, the time necessary to reach any station by the major arc. This would apply only to the regular waves, but other surface waves, moving with smaller velocities, would take longer times to reach the station. Waves of so many velocities occur that we can not work out the hodographs of them all; and we do not know at what points they start, but it is probable, as in the case of the regular waves, that they start very near the origin and that their velocity will be given with a sufficient approximation by dividing the distance of the station by the time interval of their arrival after the occurrence of the shock. With this method it is very easy to find the time interval of the arrival of waves having the same velocity by the major arc. Let  $T$  represent this interval and  $t$  the interval by the minor arc; let  $d$  be the distance in degrees by the minor arc; then we find, very simply,

$$T = t \frac{360^\circ - d}{d} \quad \frac{(T - t)}{2} = \frac{1(180^\circ - d)}{d}$$

These expressions do not contain the velocity explicitly, and apply to surface waves having any constant velocity. The quantities  $\frac{360}{d}$  and  $\frac{180 - d}{d}$  are constant for each station; and we merely have to multiply the first by  $t$ , the time interval of the surface waves by the minor arc, to obtain the interval after which the corresponding waves would arrive

by the major arc; or we may find the interval between the arrivals of the waves by the two routes by multiplying the second quantity by  $2t$ . This process can be carried out graphically with ease for seismograms having a small time scale, such as those of Milne pendulums. Mark on the seismogram (fig. 30) the point  $o$ , the moment when the earthquake occurred at the focus; at any point, as for instance  $p$ , erect a perpendicular  $p'e'$ , equal in length to  $op' \frac{180^\circ}{d}$ ; draw a straight line  $oe'$ , and produce it; the

height  $pe$  of this line above any point  $p$  of the seismogram will represent half the interval after  $p$ , before the arrival of the surface waves by the major arc, corresponding to those which, following the minor arc, are recorded at  $p$ . If we cut from a sheet of paper

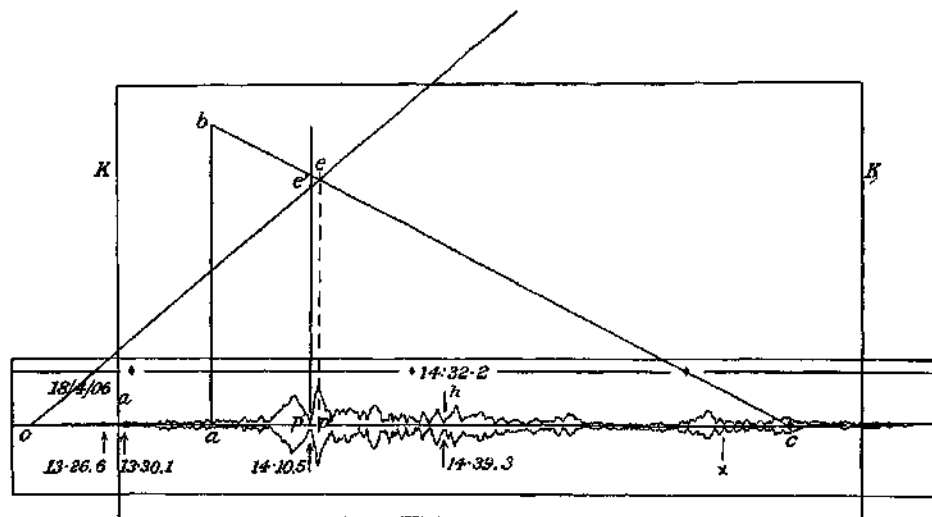

FIG. 30.

$KK$ , a triangle  $abc$ , such that  $ac$  equals  $2ab$ , and place the triangle so that  $ac$  lies along the medial line of the seismogram, the point  $c$  will mark the place where the major arc waves, corresponding to the minor arc waves recorded immediately under the point where  $be$  cuts  $oe'$ , will be recorded; by this device the whole seismogram can be examined in a few minutes. This method must be modified to apply to seismograms with open time scales, and it then requires a very large space; it is simpler, with such seismograms, to calculate  $T$  directly, with a slide-rule, from the first expression given above. When we apply this graphical method to the Milne seismograms we find, in the majority of cases, that there are marked swellings on the seismogram at the time the waves of the strong motion would arrive by the major arc. The seismograms of instruments with open time scales yield much less definite results; indeed, in the majority there is no sufficiently well-marked increase in amplitude to make one certain that the major arc waves have produced any sensible effect.

The seismograms yield various results, as follows:

*Honolulu.* — The swellings from  $16^h 00^m$  to  $16^h 18^m$  mark waves arriving by the major arc corresponding to the strongest motion of the direct minor arc waves. If the strong motion recorded at  $14^h 30^m$  is due to surface waves, the corresponding major arc waves would appear at  $24^h$ , long after the record was over. A small disturbance lasting for an hour is reported about 45 minutes after this time. If the movement mentioned is really due to surface waves arriving by the minor arc, their velocity of propagation would be about 1 km./sec, which is so extremely slow that we are led to discard this explanation of its origin.

*San Fernando.* — The strong group at  $15^{\text{h}} 43^{\text{m}}$  is due to major arc waves corresponding to the strongest part of the motion.

*Kew.* — Major arc waves arrive at  $16^{\text{h}} 08^{\text{m}}$ . Upsala and Kobe show nothing.

*Paisley.* — Major arc waves would be expected at  $16^{\text{h}} 05^{\text{m}}$ . There are many beads in this part of the seismogram, but none especially strong. The very strong swelling,  $16^{\text{h}} 13^{\text{m}}$  to  $16^{\text{h}} 22^{\text{m}}$ , corresponds to minor arc waves arriving 4 minutes after the end of the strongest motion.

*Edinburgh.* — Major arc waves at  $16^{\text{h}} 08^{\text{m}}$  and  $16^{\text{h}} 11^{\text{m}}$ .

*Bidston.* — Major arc waves from  $15^{\text{h}} 40^{\text{m}}$  to  $16^{\text{h}} 00^{\text{m}}$ ; but the earlier and equally strong beads would correspond to much smaller direct waves.

*Tokyo.* — Professor Omori places the arrival of the major arc waves at  $15^{\text{h}} 31^{\text{m}}$ . They would correspond to the direct waves arriving at  $13^{\text{h}} 48.5^{\text{m}}$ .

*Coimbra.* — Major arc waves arrive at  $15^{\text{h}} 40^{\text{m}}$ . The swelling at  $15^{\text{h}} 21^{\text{m}}$  corresponds to the beginning of the long waves which are apparently not so strong. There is a slight increase in intensity at Göttingen at  $15^{\text{h}} 40^{\text{m}}$  and  $15^{\text{h}} 48^{\text{m}}$ . The latter is also apparent at Coimbra. There is no evidence of major arc waves at Jena.

*Irkutsk.* — The major arc waves would be expected at a point on the seismogram opposite the last hour mark, but nothing appears.

*Vienna.* — Major arc waves are due at  $15^{\text{h}} 32.5^{\text{m}}$ , but the seismogram at this point does not differ from the previous part of the record.

*Wellington.* — The large swellings before  $x$  and after  $e'$  are the major arc waves corresponding to the two large swellings on each side of  $e$ , but the major arc waves due to the large movement at  $14^{\text{h}} 25^{\text{m}}$  are not evident.

*Bombay.* — Major arc waves should appear at the gap in the seismogram. The strong swelling at  $15^{\text{h}} 10^{\text{m}}$  corresponds to the beginning of the long waves, but it is so much stronger than the record of the direct waves that we can not correlate them.

*Batavia.* — Nothing definite appears at  $15^{\text{h}} 14.5^{\text{m}}$  and  $15^{\text{h}} 39^{\text{m}}$ , when the major arc waves would be expected.

*Perth.* — There are so many swellings that it is not possible to identify positively the major arc waves. The large swelling at  $15^{\text{h}} 05.5^{\text{m}}$  corresponds to the beginning of the long waves at  $14^{\text{h}} 18.3^{\text{m}}$ , but it is so much stronger than the direct waves that we can not consider it related to them.

If we attempt to find the major arc waves corresponding to the direct waves which produce the largest earth-amplitudes, as they are given in table 19, page 138, we find the evidence of their existence entirely negative. The times of arrival of the direct waves and the major arc waves at several stations are contained in the following table:

TABLE 15.—•Times of Arrival of Corresponding Minor and Major Arc Waves.

STATION.	MINOR ARC WAVES.		MAJOR ARC WAVEB.	
	<i>m.</i>	<i>s.</i>	<b>m.</b>	<b>s.</b>
Upsala . . . . .	13	51	15	36
Göttingen . . . . .	13	53.5	15	38
Leipzig . . . . .	13	55.5	15	37.5
Jena . . . . .	13	59	15	59.5
Vienna . . . . .	14	17.5	15	14.5
Batevia . . . . .	14	36.5	15	39

There are three stations situated practically on the same great circle passing thru the origin: Coimbra ( $81.4^{\circ}$ ), San Fernando ( $85.3^{\circ}$ ), and Wellington ( $262.4^{\circ}$ ), and they all have Milne pendulums. The major arc waves which arrive at Wellington at  $15^{\text{h}} 36^{\text{m}}$  cause the latter part of the strong motion at Coimbra at  $13^{\text{h}} 57^{\text{m}}$ . They should appear at

San Fernando at 13<sup>h</sup> 59<sup>m</sup>, and probably are indicated by the strong motion a minute earlier; the major arc waves arriving at Wellington at 15<sup>h</sup> 52<sup>m</sup> appear at Coimbra at 14<sup>h</sup> 01<sup>m</sup>, and cause the strong motion at San Fernando at 14<sup>h</sup> 04<sup>m</sup>. The direct waves at Wellington at 14<sup>h</sup> 07<sup>m</sup> and 14<sup>h</sup> 12.5<sup>m</sup> are due at San Fernando at 15<sup>h</sup> 41<sup>m</sup> and 15<sup>h</sup> 50<sup>m</sup> and are undoubtedly represented by the strong swelling about 15<sup>h</sup> 43<sup>m</sup>; they are due at Coimbra at 15<sup>h</sup> 43<sup>m</sup> and 15<sup>h</sup> 53<sup>m</sup>; these are weak parts of the curve, but probably the swellings a few minutes earlier than these times represent the waves we are considering.

We must conclude, from the foregoing survey, that altho the strong motion arriving by the major arc makes itself evident at some stations, perhaps on account of synchronism of its period and that of the recording instrument, at other stations it can not be detected. The small time scale of the Milne seismograms is much better adapted for identifying the major arc waves than the open time scale of other instruments.

#### EQUALITY OF VELOCITIES ALONG DIFFERENT PATHS.

As already pointed out, all the distant stations had instruments of low magnifying power and apparently were too late by various amounts in recording the shock; so we must confine our attention to stations less than 100° distant. On comparing the times of arrival of the various phases (given in table 7, page 116) at stations nearly equally distant, we can not find any differences, greater than the errors of observation, which might be dependent upon the direction of the station from the origin; and this applies to all three phases of the motion. Thus, Honolulu receives the second preliminary tremors a little earlier than the observations at stations in the east of North America would lead us to expect (see hodograph, plate 2), but the first preliminary tremors arrive at the expected time. The paths to Honolulu and these stations are totally different, the first being under the Pacific and the other across the continent of North America, as shown in plate 1.

The Japanese, on the one hand, and the British and Scandinavian stations, on the other, are about equally distant from the origin; the path to the former lies under the deep Pacific, that to the latter across North America, Greenland, and under the shallow North Sea; but we do not find a greater difference between the times of arrival at these two groups of stations than we do between the individual stations of the same group.

Irkutsk and Jurjew are at practically the same distance from the origin; the path to Irkutsk passes under the Pacific, across Alaska and northeastern Asia; the path to Jurjew crosses North America and Greenland and continues under the North Sea; yet the times of arrival at the two stations are within a very few seconds of each other.

We conclude, therefore, that the velocity of propagation is independent of the position of the projection of the path on the earth's surface; or, at least, is too little affected by it to be detected by our observations.

#### COMPARISON OF THE HODOGRAPHS OF THE CALIFORNIA EARTHQUAKE WITH OTHER OBSERVATIONS.

When we compare the hodographs obtained from the California earthquake with those given by Professor Milne in 1902\* and with those of Professor Oldham, 1900,<sup>3</sup> we find that our times of arrival of the first and second preliminary tremors are, for the greater part of the curves, about 2 minutes earlier. This appears to be due to lack of accuracy in the earlier observations, and a glance at the earlier diagrams will show that the curves are drawn from observations differing greatly among themselves.

<sup>1</sup> Report Seis. Com. B. A. A. S., 1902.

\* On the Propagation of Earthquake Motion to Great Distances. Phil. Trans. R. S., 1900-1901, vol. 194, pp. 135-174.

The hodograph of the "large waves" of Professor Milne in the earlier observations does not refer to the same surface waves as those which are here tabulated as *regular waves*, but to the time of maximum displacements on the seismograms. The position of the maximum is very largely dependent upon the proper period of the recording pendulum, and the instruments whose records we have of the California earthquake differed so greatly in this respect that it is not possible to identify as a maximum any characteristic part of the disturbance; except for a limited number of seismograms.

In his very interesting memoirs on the propagation of earthquake motion, Prof. G. B. Rizzo gives hodographs of the two Calabrian earthquakes of September 8, 1905, and October 23, 1907. The former was a severe earthquake and was recorded all over the world. The latter was much smaller and satisfactory observations were only obtained up to distances of about  $22^\circ$ . The hodographs of the first and second preliminary tremors agree very well with my curves, except about  $20^\circ$  and in the immediate neighborhood of the origin, where Professor Rizzo has made his curve convex upward to represent the assumed changes in surface velocity; and he has measured his times from the estimated time of arrival of the disturbance at the epicenter, whereas I have measured time from the actual time of occurrence of the shock at the focus, and have assumed the velocity of 7.2 km. per second for short distances from it.

Professor Omori, in his very complete account of the seismograph records of the Kangra earthquake of April 4, 1905/ gives the hodographs of the first and second preliminary tremors and a later phase of the principal part; the latter, however, does not correspond to the regular waves which I have recorded. The hodographs of the first two phases correspond fairly well with those of the California earthquake<sup>2</sup> up to distances of about  $60^\circ$  for the first preliminary tremors and  $90^\circ$  for the second preliminary tremors; but beyond they diverge greatly. It is rather curious that the observations of the Indian earthquake are most numerous between  $37^\circ$  and  $60^\circ$ , in which interval there is but one observation of the California earthquake; whereas, between  $70^\circ$  and  $100^\circ$ , where the great majority of the observations of the California earthquake lie, there are but four very unsatisfactory observations of the Indian earthquake. The cause of the disagreement between the observations at the greater distances is very evident. All the observations of the Indian earthquakes at distances greater than  $60^\circ$  are made with instruments of very low magnifying power, and it is hardly possible that the true beginning of the disturbance has been recorded. With regard to the second preliminary tremors it is a question of the interpretation of the seismograms. Of the four observations which Professor Omori uses beyond  $90^\circ$  three are from Bosch-Omori 10 kg. instruments, and I think it quite impossible from an examination of their seismograms to determine where the second preliminary tremors really began. The other record, at Wellington, was made by a Milne pendulum, and the time I take to mark the arrival of the second preliminary tremors is nearly 10 minutes earlier than that taken by Professor Omori, and is between 2 and 3 minutes later than my curve would lead us to expect. The record at Christchurch,  $0.7^\circ$  nearer the origin, is 2.5 minutes earlier. The Milne seismograms from Victoria, Toronto, Baltimore, and Christchurch (from  $97.7^\circ$  to  $115^\circ$ ) are not used by Professor Omori in making his hodograph of the second preliminary tremors, tho he reproduces them among his plates. As I read them, the times of arrival of the second preliminary tremor are in fair agreement with my curves and are from 8 to 12 minutes earlier than the times adopted by Professor Omori for similar distances. He is thus led to nearly linear hodographs of the first and second preliminary tremors, and consequently to a linear relation between the distance of an earthquake origin and the duration of the first preliminary tremors.

<sup>1</sup> Report on the Great Indian Earthquake of 1905. Pub. Earthquake Investigation Committee in Foreign Languages, Nos. 23 and 24.

\* Professor Omori also gives the velocities obtained from the California earthquake in the same report, but he has taken the time of the shock a half minute too early.

TABLE 16. — *Transmission Intervals (in minutes) for Three Earthquakes.*

DISTANCE.	FIRST PRELIMINARY TREMORS.				SECOND PRELIMINARY TREMORS.			
	Indian.	Calabrian.	California.	Average.	Indian.	Calabrian.	California.	Average.
0	<i>min.</i>	<i>min.</i>	<i>min.</i>	<i>min.</i>	<i>min.</i>	<i>min.</i>	<i>min.</i>	<i>min.</i>
10	2.6	2.24 <sup>1</sup>	2.4	2.41	4.6	4.06	3.85	4.17
20	4.5	4.26*	4.3	4.35	8.4	8.05	7.6	8.02
30	6.2	6.12	6.1	6.14	11.3	11.26	10.9	11.15
40	7.6	7.35	7.7	7.55	13.9	13.80	13.8	13.83
50	9.0	8.51	9.0	8.84	16.2	16.24	16.3	16.25
60	10.6	9.67	10.2	....	18.9	18.68	18.6	18.73
70	12.2	10.78	11.35	....	20.7	21.12	20.6	20.81
80	13.9	11.89	12.3	....	24.7	23.57	22.25	....
90	15.7	13.00	13.25	....	27.5	26.00	24.0	....
100	17.3	14.11	14.2	....	30.4	28.56	25.6	....

In table 16 have been collected the transmission intervals in minutes for the first and second preliminary tremors of the Indian earthquake of April 4, 1905, the Calabrian earthquake of September 8, 1905, and the California earthquake of April 18, 1906. The data for the Indian earthquake are taken from plates in and iv of Professor Omori's report, that of the Calabrian earthquake from table 2 of Professor Rizzo's first memoir,<sup>1</sup> and that of the California earthquake from table 11, page 120 of this report. A very close agreement exists up to 50° for the first preliminary tremors and up to 70° for the second preliminary tremors, with the exception of the interval at 20°, and we may accept the averages given as representing to a very fair degree of accuracy the time intervals necessary to travel the corresponding distances. The four intervals marked are from Professor Rizzo's second memoir<sup>2</sup> and refer to the Calabrian earthquake of October 23, 1907; they are a little shorter, and I think a little more accurate, than the corresponding intervals for the earlier earthquake.

#### DETERMINATION OF THE DISTANCE OF THE ORIGIN OF AN EARTHQUAKE.

Professor Milne in 1898<sup>3</sup> showed that the distance of an earthquake from the recording station could be determined by the interval of time between the beginning of the disturbance and the arrival of the large waves, and he drew a preliminary curve to represent this relation. In 1902<sup>4</sup> he gave more accurate results based on more abundant data. Professor Omori has followed up this subject and has drawn curves and given equations to determine the distance of the origin from the duration of the first preliminary tremors and from the interval between the first preliminary tremors and the long waves.<sup>5</sup> His relations are linear, one equation being given for near origins and a second for distant origins.

In fig. 31 curves are drawn which are taken directly from the hodographs in plate 2 and show the interval elapsing between the first and second preliminary tremors, between the first preliminary tremors and regular waves, and between the second preliminary tremors and regular waves. These three curves are of course not independent; any one of them could be deduced directly from the other two. By means of them a typical seismogram will give two independent determinations of the distance of an earthquake origin. These

<sup>1</sup> Nuovo Contributo allo Studio della Propagazione dei Movimenti Sismici, Acad. R. d. Scienze di Torino, 1907-1908, vol. LIX, p. 415.

<sup>2</sup> Sulla Velocità di Propagazione della Onde Sismiche, Acad. R. d. Scienze di Torino, 1905-1906, vol. LXVII.

<sup>3</sup> Report Seis. Com. B. A. A. S., 1898.

<sup>4</sup> Same, 1902.

<sup>5</sup> Pub. Earthquake Investigation Commission in Foreign Languages, Nos. 5 and 13, Bull. Imperial Earthquake Investigation Commission, vol. n, pp. 144-147. A Report on the Great Indian Earthquake of 1905. Publications, etc., No. 24, pp. 179-186.

curves have a certain advantage over most similar curves heretofore given because the time and origin of the California earthquake are known to a higher degree of accuracy and because more and better instruments have recorded this shock than were in use in earlier times. Nevertheless, they are free-hand curves, and the observations not perfectly concordant, both of which facts reduce their accuracy. Moreover, the duration of the first preliminary tremors increases very slowly with the distance from the origin, which makes the determination of the distance by means of the interval rather inaccurate. It will be seen that the lines are not straight, altho their curvatures are not very great. The interval between the first and second preliminary tremors are given from the origin, because both these phases apparently begin there, but the curves dependent upon the regular waves start about  $10^\circ$  from the origin; the first observation we have of the regular waves is at a distance of about  $20^\circ$ ; and the parts of the curves nearer the origin are drawn on the supposition that the hodograph of the regular waves continues as a straight line to within  $10^\circ$  or so of the origin.

The time of the occurrence of the shock, and therefore the early part of the hodographs, is based on the assumption that the velocity of the first preliminary tremors is 7.2 km./sec. near the origin, and that of the second preliminary tremors in the same region, 4.8 km./sec. These values fit very well into the general curves of the hodographs; but that would also be true of values differing 10 or 15 per cent from them; but it would hardly be true for values differing more than this.

The duration of the first preliminary tremors does not depend upon those values, but upon the record at Mount Hamilton, where it was 9 seconds.

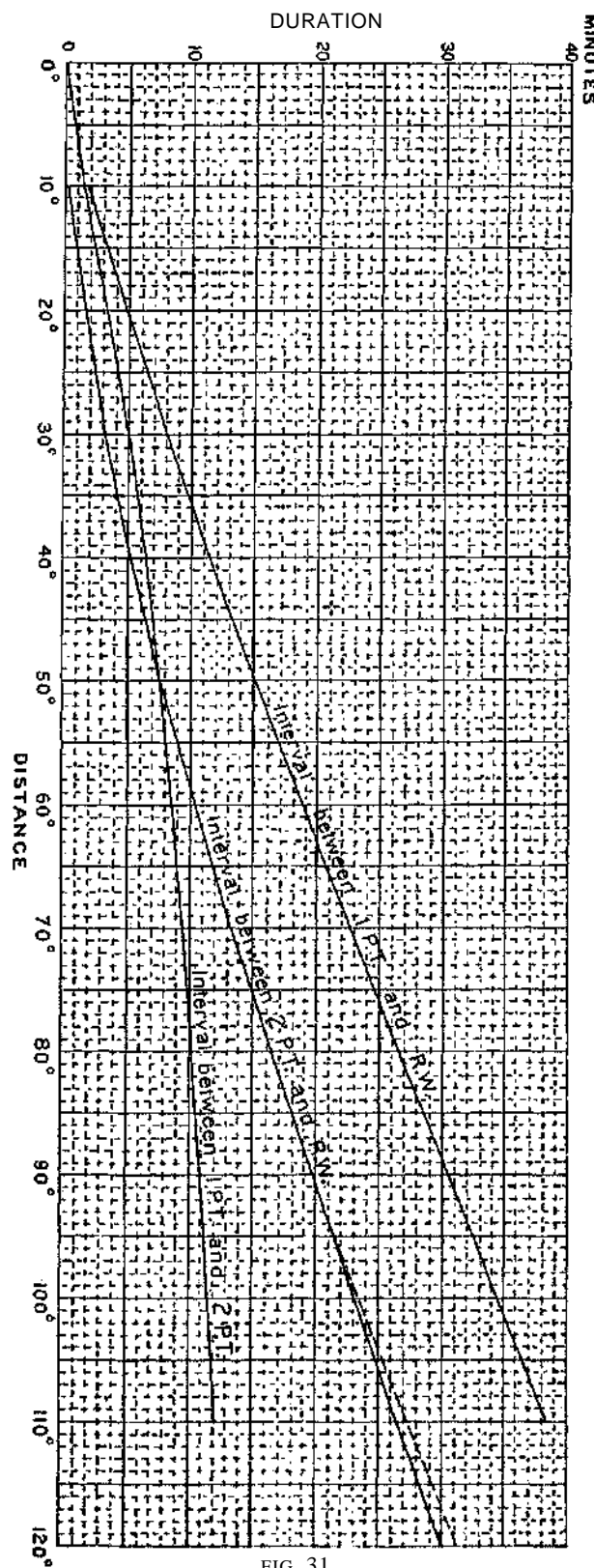

FIG. 31.

Mount Hamilton is about 128 km. from the origin, and if we assume that for distances of a few hundred kilometers the duration of the first preliminary tremors is proportional to the distance which the approximate straightness of the hodographs of the first two phases near the origin indicates, we find the following relation between the distance  $d$  and the duration  $I'$  of the first preliminary tremor:

$$d(\text{km.}) = 14.2 * I' (\text{sec}).$$

As the position of the origin is not known nearer than 20 km. the number in the second member may lie anywhere between 12 and 16.2.



PERIODS AND AMPLITUDES.

The study of the seismograms reveals the periods of the vibrations in different parts of the disturbance as recorded at a number of stations. The actual amplitude of the earth movement can only be determined by a calculation which depends upon the period of the waves, the period of the pendulum, and the constants of the instruments. The calculation is made in accordance with the formulas, equations 79 or 81, page 169. In many cases the period of the pendulum is the same as that of the vibration and then, if there is not very strong damping, the magnifying power becomes indefinitely large and is undeterminable; this is the condition at many stations where large movements are recorded by the seismographs; but it has been possible, in a number of cases, to determine roughly the true movement of the ground. The amplitudes on the two components at right angles to each other do not always reach their maxima at the same time; it sometimes happens that the movement is alternately strong on one component and the other. This was the case at Porto Rico, Upsala, and Pavia. Even when the maxima occur on the two components at the same time, one does not always get the true amplitude of the earth's motion by taking the square root of the sum of the squares of the two components, for the difference of phase has an influence; but this is the only method we can use, and the quantities given in the column headed "Poss. total" in table 19 were obtained in this way.

DURING THE PRELIMINARY TREMORS.

The vibrations during the first preliminary tremors frequently have periods in the neighborhood of 5 seconds; other periods were also present, but were not so persistent. At Jurjew the period during the first preliminary tremors was 29 to 30 seconds. It seems as tho there were many periods present and that the period which was close to that of the instrument was singled out and made prominent. At Sitka a period of about 17 seconds was shown.

During the second preliminary tremors vibrations of various periods were also present, but those which had the largest amplitude seem to be about 15, 20, and 28 seconds.

TABLE 17. — *Periods and Amplitudes during the Preliminary Tremors.*

STATION.	DISTANCE.		DIRECTION OF APPROACH.	COMPONENT.	FIRST PRELIMINARY TREMORS.		SECOND PRELIMINARY TRIMOWU		
	°	km.			Amplitude.	Period.	Amplitude.	Period.	Time.
Sitka . . .	20.72	2302	N. 27° W.	North . . .	mm. 0.48	sec. 17	mm. 0.215?	Me. 15	h. m. »»»
Ottawa . . .	35.37	3930	N. 85° W.	North . . .	0.004	6.7*	.....	..	.....
Washington . . .	35.44	3937	N. 75° W.	East . . .	0.005	6 <sup>1</sup>	.....	..	.....
Upsala . . .	76.80	8533	N. 29° W.	North . . .	.....	.....	0.2 i'	28	13 "k
Osaka . . .	77.30	8589	N. 55° E.	North . . .	0.0013	*4	0.37	19	13 44
Jurjew . . .	80.27	8918	.....	East . . .	0.01	5	.....	..	.....
Potsdam . . .	81.35	9039	N. 37° W.	.....	.....	29-30	.....	..	.....
Irkutsk . . .	80.82	.....	.....	North . . .	.....	5	0.17'	23	.....
Gb'ttingen . . .	81.36	9040	N. 39° W.	East . . .	.....	.....	0.12	27	13 45
Leipzig . . .	82.40	9155	N. 38° W.	East . . .	.....	37'60	.....	..	.....
Jena . . .	82.45	9161	N. 39° W.	Vertical . . .	.....	1,2,5	0.041	16	Him
Munich . . .	84.75	9417	N. 39° W.	North . . .	0.0024	5,8	.....	..	.....
Vienna . . .	86.37	9596	N. 37° W.	East . . .	0.0018	5,9	0.028	20	13*3ft
Batavia . . .	124.99	13887	N. 50° E.	East . . .	0.0052	4,8	0.1 i'	ill	13 3ft
				North . . .	0.0023	4,10	0.0155	20	.....
				East . . .	0.0023	5	0.0034	15	13 3ft
				North . . .	0.022	5	.....	..	.....
				East . . .	0.1118	.....	.....	..	.....
				North . . .	0.00M	5, 8, 10	0.0 Vifi ?	M	.....

\* Uncertain on account of clewaeM of p<i>it<sup>h</sup>

The amplitudes recorded are very small and are not very regular. The nearest point where a determination could be made for the first preliminary tremors was Sitka, and there the earth-amplitude was just under 0.5 mm. At Ottawa it had already diminished very greatly, being about one-hundredth as much for both components. These values are somewhat uncertain, as the periods were very near those of the pendulums. Table 17 shows the amplitudes at a number of stations; in general they lie between 0.002 mm. and 0.02 mm. The reason for the absence of a progressive diminution is not at all clear. It does not seem to be sufficiently accounted for by differences in the foundation. It is possible that the discordance may be largely due to inaccuracy in the constants of the instruments, especially the omission of the solid friction, and also, possibly, to the application of the formula to parts of the record where the movement has not been sufficiently regular for the formula to apply accurately.

During the second preliminary tremors there is a very large increase in the amplitude, to about 10 times that of the first preliminary tremors; we find the same kind of irregularity in the amplitudes at successive stations but we do not find the proportion between the amplitudes of the first and second preliminary tremors constant; at Leipzig, the amplitude of the second preliminary tremors was 10 times that of the first preliminary tremors, whereas at Jena it was 20 times as great. This probably indicates a lack of accuracy in the determination of earth-amplitudes.

DURING THE REGULAR WAVES AND THE PRINCIPAL PART.

*In the megaseismic district.* — The temporary nature of the vibrations makes it impossible to get satisfactory measures of the amplitudes, unless a permanent record of some kind is made. There are, fortunately, a few such records which enable us to form a rough conception of the amount of the movement.

Professor Omori, guided apparently by the damage done, estimates that, on the filled-up grounds of San Francisco, the amplitude of the vibration was 50 mm. (2 inches), and the period 1 second.<sup>1</sup> The distance from the fault was about 14 km.

On the rock at Berkeley Observatory (distant 30 km.) the vertical component of the amplitude was 23 mm. (1 inch), and the horizontal component, according to the Ewing duplex pendulum, more than 11 mm.

At Mare Island (distant 40 km.) Professor See estimated the horizontal amplitude in the soft made ground at 50 to 75 mm. from the displacement of loose dirt about piles which supported buildings (vol. I, p. 212).

At a number of stations in the megaseismic district, given in table 18, which were provided with simple instruments, the amplitude of the movement was greater than the instruments could record, that is, in general, was greater than 10 mm.; and it is probable that it was several times greater.

TABLE 18. — *Amplitudes in the Megaseismic District.*

STATION.	DISTANCE FROM FAULT.	COMPONENT.	DISPLACEMENT.
	<i>km.</i>		<i>mm.</i>
Los Gatos . . . . .	6	Horizontal	5+
San Francisco . . . . .	14	Horizontal	50
San Jose . . . . .	18	Horizontal	10+
Oakland . . . . .	24	Horizontal	10 +
Alameda . . . . .	29	Horizontal	10+
Berkeley . . . . .	30	Vertical	23
		Horizontal	11+
Mount Hamilton . . . . .	35	North-south	40+
		East-west	40+
Mare Island . . . . .	40	Horizontal	50 to 75
Carson City . . . . .	291	Horizontal	11

<sup>1</sup> Bull. Imperial Earthquake Investigation Commission, vol. 1, p. 19.

At Mount Hamilton ( $1.16^\circ$  or 129 km. from the origin and 35 km. from the fault) the 3 component Ewing instrument indicated amplitudes, both in the north-south and east-west directions, greater than 40 mm.

At Carson City ( $2.62^\circ$  or 291 km.) the horizontal amplitude was about 11 mm. in all directions.

*Beyond the megaseismic district.*— We have collected in table 19 the periods and the greatest earth-amplitudes at all the stations for which we have sufficient data to determine these quantities. In a few cases they are taken directly from published reports. At many stations there was so close a correspondence between the period of the vibrations and that of the pendulum during the very strong motion that it was impossible to make any determination of the earth-amplitude.

It will be seen that the periods of vibration during the regular waves were, in general, not very far from 30 seconds, tho in a few cases they were 10 or 12 seconds less, and in a few 10 or 20 seconds more. During the principal part the periods were principally between 17 and 25 seconds.

Where we have determinations of the earth-amplitude during both the regular waves and principal part at the same station, the former seems to be somewhat the larger, altho the instrumental record on the seismogram is almost always larger during the principal part. This is due to the variations in the magnifying power of the instrument on account of difference in periods.

Altho the amplitudes do not diminish regularly with the distance from the origin, nevertheless with the exception of a few abnormal values, which are not understood, there is in general a reduction of amplitude with the distance. In the megaseismic region we found that these amplitudes were 50 mm. or more; at distances of  $30^\circ$  to  $50^\circ$  they have diminished to about 5 mm., and we must go as far as  $100^\circ$  or so to find amplitudes less than 1 mm. We see, therefore, that the great world-shaking earthquakes cause movements of the earth at great distances which are by no means inconsiderable, and the only reason why they are not felt is that the period is very long, and, therefore, the movement too slow to make them evident to our senses.

In attempting to determine the depth of the fault (page 13) we were led to assume that the energy is sent out from the fault-plane proportionally to the cosine of the angle between the direction of propagation and the normal. Altho this will probably hold approximately in the neighborhood of the fault, it does not hold at a distance, where the distribution of the energy, so far as we can tell from the altogether unsatisfactory determinations that could be made, is entirely independent of the direction from the origin. For instance, Sitka and Tacubaya, whose directions make angles  $16^\circ$  and  $29^\circ$ , respectively, with the direction of the fault, have apparently instrumental amplitudes similar to those of the stations in the eastern part of North America, whose direction is nearly at right angles to the fault-plane. Pilar, Argentina, and the Cape of Good Hope, whose directions make angles of  $12^\circ$  and  $51^\circ$  with the fault, gave very small records, whereas Mauritius (nearly  $35^\circ$ ) gave a much larger record. Calcutta, Kodaikanal, and Bombay ( $5^\circ$  to  $16^\circ$ ) also gave much larger records.

In looking over the table of earth-amplitudes, to compare the results between stations at about the same distances from the origin, but in different directions, we find the irregularities so great that no satisfactory conclusions can be drawn. We notice, however, that Zi-ka-wei had about the same amplitude during the principal part as Carloforte and Sarajevo; and that the amplitudes at Sofia, Catania, and Manila do not differ greatly during the regular waves; but these comparisons carry very little conviction with them, because of the great variations between the amplitudes at various European stations, which do not differ greatly in their distances from the focus nor in their directions from it.

TABUS 19.—Periods and Amplitudes during the Regular Waves and the Principal Part.

STATION.	DIS-TANCE.	COMPONENT.	REGULAR WAVES.				PRINCIPAL PART.					
			Ampli-tude.	POM. total.	Period.	Time.	Ampli-tude.	POBS. total.	Period.	Time.		
			mm.	mm.	sec.	h.	m.	mm.	mm.	sec.	h.	m.
Cheltenham .	35.64	North	2.3+	5	13	13	34	3.2+	5	13	13	34
		East	3.6	5.2	33	13	50-52	3.76	5.2	9	13	36
Upsala . . .	76.80	North	1.7	4	41	13	53	2.7	4	23.2	13	56
		East	0.8+	4	30	13	53	2.2	4	28	13	56
Potsdam . . .	81.35	North <sup>1</sup>	0.97+	1.6+	30	13	52-55	1.5	1.6+	22	13	56
		North <sup>2</sup>	1.31+	1.6+	30	13	52-55	0.52+	1.6+	20	13	59
		East <sup>2</sup>	1.64	1.6+	49	13	52-55	0.52+	1.6+	20	13	59
		Vertical	0.7	1.6+	49	13	52-55	0.7	1.6+	14.5	13	59
Leipzig . . .	82.40	North	0.58	2.2	34.5	13	55.7	1.55/	1.65	16.4	13	57.5
		East	1.81	2.2	30	13	54-56	2.0+	1.65	20	13	57.5
Jena . . . .	82.45	North	2.6	3.2	30	13	54-56	1.5+	2.5+	20	13	58
		East	1.9	3.2	30	13	54-56	1.5+	2.5+	20	13	58
Munich . . .	84.75	North	0.47	1.35	29.5	13	52	0.77+	1.47+	22.5	13	58
		East	1.26	1.35	35.5	13	52	1.25+	1.47+	24.2	13	58
		North 30° east	0.59	1.35	35.5	13	52	1.25+	1.47+	24.2	13	58
Strassburg .	82.91	East	0.47	1.35	35.5	13	52	1.25+	1.47+	24.2	13	58
Tortosa . . .	85.65	Average	1.36	1.35	35.5	13	52	1.25+	1.47+	24.2	13	58
		Northeast	2.2	1.35	35.5	13	52	1.25+	1.47+	24.2	13	58
Pavia . . . .	86.20	Southwest	3.1	1.35	35.5	13	52	1.25+	1.47+	24.2	13	58
		North	0.19	1.35	35.5	13	52	1.25+	1.47+	24.2	13	58
Vienna . . .	86.37	East	0.21	1.35	35.5	13	52	1.25+	1.47+	24.2	13	58
		North	0.14	1.35	35.5	13	52	1.25+	1.47+	24.2	13	58
		East	1.1	1.35	35.5	13	52	1.25+	1.47+	24.2	13	58
Triest . . . .	87.74	Vertical	0.9	1.35	35.5	13	52	1.25+	1.47+	24.2	13	58
		North	1.42	1.35	35.5	13	52	1.25+	1.47+	24.2	13	58
Budapest . .	87.93	North*	2.5	1.35	35.5	13	52	1.25+	1.47+	24.2	13	58
		East <sup>6</sup>	1.06	1.35	35.5	13	52	1.25+	1.47+	24.2	13	58
		North*	0.33	1.35	35.5	13	52	1.25+	1.47+	24.2	13	58
O'Gyalla . .	88.08	East <sup>7</sup>	0.64?	1.35	35.5	13	52	1.25+	1.47+	24.2	13	58
		North <sup>8</sup>	4.1	1.35	35.5	13	52	1.25+	1.47+	24.2	13	58
Florence (Xi-meniano) .	88.23	East <sup>8</sup>	2.6	1.35	35.5	13	52	1.25+	1.47+	24.2	13	58
		North*	3.9?	1.35	35.5	13	52	1.25+	1.47+	24.2	13	58
Zagreb . . .	88.33	East <sup>9</sup>	2.8?	1.35	35.5	13	52	1.25+	1.47+	24.2	13	58
		North	1	1.35	35.5	13	52	1.25+	1.47+	24.2	13	58
Pola . . . .	88.33	East	1.9	1.35	35.5	13	52	1.25+	1.47+	24.2	13	58
		North	10.1	1.35	35.5	13	52	1.25+	1.47+	24.2	13	58
Quarto-Castello .	88.40	East	1.18	1.35	35.5	13	52	1.25+	1.47+	24.2	13	58
		East	0.5	1.35	35.5	13	52	1.25+	1.47+	24.2	13	58
Zi-ka-wei . .	88.49	East	0.39	1.35	35.5	13	52	1.25+	1.47+	24.2	13	58
		Northwest	1.1	1.35	35.5	13	52	1.25+	1.47+	24.2	13	58
		North	0.821	1.35	35.5	13	52	1.25+	1.47+	24.2	13	58
RoccatiPapa .	90.48	East	1.14/	1.35	35.5	13	52	1.25+	1.47+	24.2	13	58
		Northwest	0.6	1.35	35.5	13	52	1.25+	1.47+	24.2	13	58
		Northeast	0.6	1.35	35.5	13	52	1.25+	1.47+	24.2	13	58
Carloforte . .	90.71	North	Small	1.35	35.5	13	52	1.25+	1.47+	24.2	13	58
		East	0.53	1.35	35.5	13	52	1.25+	1.47+	24.2	13	58
Sarajevo . . .	90.89	East	0.46	1.35	35.5	13	52	1.25+	1.47+	24.2	13	58
		East	0.43	1.35	35.5	13	52	1.25+	1.47+	24.2	13	58
		Northwest	0.68	1.35	35.5	13	52	1.25+	1.47+	24.2	13	58
Caggiano . .	92.63	Northeast	2.2+	1.35	35.5	13	52	1.25+	1.47+	24.2	13	58
		East	0.25	1.35	35.5	13	52	1.25+	1.47+	24.2	13	58
Taihoku . . .	92.75	North	0.25	1.35	35.5	13	52	1.25+	1.47+	24.2	13	58
Sofia . . . .	93.58	Northwest	0.48*	0.84	24	14	61.5	1.66	0.84	22	14	07.8
		Northeast	0.48*	0.84	24	14	61.5	1.66	0.84	22	14	07.8
Messina . . .	94.67	Vertical	0.3	0.84	24	14	61.5	0.3	0.84	21	14	07.8
		Northeast	0.25	0.84	24	14	61.5	0.25	0.84	22	14	07.8
		Northeast	0.58	0.84	24	14	61.5	0.58	0.84	22	14	07.8
Catania . . .	95.04	Northwest	0.72	0.84	24	14	61.5	0.72	0.84	18	14	12.8
		North <sup>1</sup>	0.72	0.84	24	14	61.5	0.72	0.84	18	14	07.1
Taschkent . .	99.86	East <sup>7</sup>	3.0	0.84	24	14	61.5	3.0	0.84	24	14	10.9
		East-northeast	20	0.84	24	14	61.5	20	0.84	32	14	21.3
Manila . . .	100.46	North-northwest	0.75	0.84	24	14	61.5	0.44	0.84	18	14	08
		North	0.45	0.84	24	14	61.5	0.4	0.84	18	14	08
Batavia . . .	124.99	North	0.38	0.84	24	14	61.5	0.24	0.84	18.4	14	30.6

<sup>1</sup>Rebur-Paachwit\*.  
<sup>7</sup>Wiechert.

<sup>2</sup>17,000 ke.  
<sup>3</sup>< 1,200 kg.

<sup>4</sup>Vicentini.  
<sup>5</sup>Konkoly.

<sup>6</sup>Bosoh-Omori.  
<sup>8</sup>Stiattesi.

### MAGNETOGKRAPI RECORDS.

Several magnetographs at stations not very distant from the origin recorded the shock. These have been examined by Dr. L. A. Bauer/ who finds that the time of disturbance on the magnetograph corresponds to the time of arrival of the principal part, and concludes, therefore, that the effect is entirely mechanical and not magnetic. The following table shows the time of the magnetograph records and the time of arrival of the regular waves, according to Dr. Bauer.

TABLE 20. — *Times of Magnetograph Records.*

STATION.	DISTANCE.	MAGNETOGRAPH RECORD.		REGULAR WAVES.	
		<i>h.</i>	<i>m.</i>	<i>A.</i>	<i>TO.</i>
	0				
Sitka . . . . .	20.7	13	22.9	13	22.6
Baldwin . . . . .	21.8	13	24		
Toronto' . . . . .	32.9	13	25.3	<sup>2</sup> 13	24.5
Honolulu . . . . .	34.6	13	27.8	<sup>3</sup> 13	28.5
Cheltenham . . . . .	35.6	13	30	13	30
Porto Rico . . . . .	53.4	Not recorded		....	

<sup>1</sup> The Toronto record was communicated by Mr. B. F. Stupart, director of the Canadian Meteorological Service. The records of the other stations are taken from Dr. Bauer's article.  
<sup>2</sup> Time of the second preliminary tremors; the regular waves are 3.4 minutes later.  
<sup>3</sup> Not determined from the seismogram, but from the hodograph curve, plate 2.

It will be seen that the magnetographs recorded only during the time of the strong motion, which convinces us that they acted mechanically like seismographs, for if they had been affected by a magnetic disturbance due to the earthquake, the effect would have been produced long before the arrival of the slow surface waves; indeed, before the arrival of any elastic waves in the mass of the earth. The maximum disturbance of the Toronto declination needle occurred at 13<sup>h</sup> 33.6<sup>m</sup>; and the maximum recorded by the seismogram at 13<sup>h</sup> 33.3<sup>m</sup>.

Baldwin, Kansas (lat. 38° 47' N., long. 95° *IW* W.), is the only one of these stations that did not have a seismograph; and the magnetograph record began about 1.5 minutes after the regular waves must have reached there according to the hodograph. Being in the middle of the United States, far from any seismographic station, an accurate record at Baldwin would have been valuable; but the time scales of magnetographs are too small to yield close time values; and they do not, in general, record before the strong motion. The Baldwin record is therefore only valuable in so far that it does not contradict the results obtained from regular seismographs; and we can not hope that magnetograph records in the future will, in general, be important additions to the records of seismographs.

<sup>3</sup> "Magnetograph Records of Earthquakes with Special Reference to the San Francisco Earthquake." *Terrest. Magn. and Atmos. Elect.*, 1906, vol. xi, pp. 135-144.

## CONCLUSIONS.

The comparative study of the seismograms made by instruments of such varied types brings out the advantages and disadvantages of the various types and of the devices used in making the record.

*Time.* — It is extremely important that the seismograms should record accurate time. Errors may be due either to errors in the clock or to the methods of recording the time. It is to be supposed that in most observatories the error of the time-marking clock is pretty accurately known, but in some cases it seems almost impossible to escape the conviction that sufficient care has not been given to this subject.

The time marks are sometimes made by the recording point itself, or by an eclipse of the record in the case of instruments registering photographically. Neither of these methods introduces any error. If instruments record the time by special devices marking on the paper, either very close to the record or off to the side, a correction must then be made for "parallax/" or the distance between the recording point and the time-marking point. Frequently the pendulum is slightly out of the medial position of equilibrium, and the recording point is displaced to the side; the value of the parallax then changes and some special care is needed to avoid introducing an error in the determination of the time. When the time marks are made at the side of the record, 5 or 10 cm. from the recording point, it is very difficult to carry over the time from them to the record without making an error.

*Undamped instruments.* — The larger number of instruments in use are not damped. The effect of this is to cause a very uneven magnifying-power for vibrations of different periods. This is shown clearly in fig. 47, page 173, where the magnifying power of undamped instruments is seen to increase rapidly with the period of the waves, reaching infinity when this period equals that of the pendulum; and it then diminishes again with longer periods. It is evident, therefore, that an undamped instrument will not accurately reflect the character of the disturbance, but will unduly magnify the vibrations whose periods approach concordance with its own. There are numerous examples of this in the seismograms of the California earthquake. When the amplitude of the recording point has gone beyond the limits of the instrument it has almost invariably been due to abnormally high magnifying powers, caused by concordance of periods, and therefore it does not correspond necessarily, or even usually, with the time of greatest earth movements at the recording station. For instance, Porto d'Ischia and Grande Sentinella, within a few kilometers of each other, have picked out and emphasized waves of different periods.

With undamped instruments it is impossible to determine the magnifying power when the periods of the vibration and the pendulum approach each other; it can only be done satisfactorily when the wave period is less than half or greater than 1.3 times that of the pendulum. As many instruments have periods lying between 15 and 20 seconds, which correspond to the periods occurring during the principal part, we are frequently unable to determine their magnifying power and the true amount of the disturbance. Long-period instruments would give better results for short-period vibrations, and *vice versa*; but the magnifying power of short-period instruments for long periods is very greatly reduced. For instance, the Vicentini pendulum at Manila has a mechanical magnifying power of 100. Its period was 2.4 seconds during the strong motion; the period of the waves was 25 seconds; and the actual magnifying power of the instrument for these waves was a little less than 1.

*Damped instruments.* — Of the instruments which were damped the majority were not damped enough. There are two great advantages in strong damping. The pendulum has a more uniform magnifying power for waves of different periods, and it takes up the true movement more quickly. The curves in fig. 47 show the variations in magnifying powers for different periods and for different degrees of damping. Where the damping is insufficient there is a distortion of the record, as in the case of undamped instruments, but to a less degree. It will be noticed that when the damping ratio is 8 : 1 the magnifying power is nearly constant for all periods shorter than that of the pendulum itself. For longer vibration periods the magnifying power gradually diminishes, but not excessively. When the vibration period is twice as long as that of the pendulum the magnifying power is about 0.8 as great as it would be for an undamped pendulum; and for periods longer still the magnifying power becomes more nearly equal to that of an undamped instrument.

With the damping ratio mentioned the free movement of the pendulum dies out very rapidly. If the pendulum is displaced 64 mm. and allowed to swing freely its amplitude will die down to 1 mm. after one whole vibration. Therefore the free movement of the pendulum will always disappear rapidly, and it will record pretty closely the true movement of the ground. Prince Galitzin advocates "dead-beat" instruments, where the damping is in the proportion 8 : 1. Under this heavy damping he has shown by experiment that the free movement disappears immediately and the pendulum follows very closely the movement of the ground; but the curve in fig. 47 shows that the magnifying power is not constant, but varies continuously for different periods, and therefore a calculation must always be made before we can compare the relative amplitudes in different parts of the record. It seems to me therefore that the most advisable damping ratio is 8 : 1.

*Period of the pendulum.* — If the vibrations have a much longer period than the pendulum, the magnifying power of the instrument is greatly reduced. The advantage of long periods in undamped pendulums is that they hold up the magnifying power for long-period waves. For waves of very short period there is no advantage in giving a long period to the pendulum. For instance, other things being equal, a pendulum with a period of 10 seconds and one with a period of 60 seconds would have practically the same magnifying power for waves whose period was 1 second.

We have seen that when the instrument is damped in the ratio of 8 : 1 the magnifying power varies little for periods up to that of the pendulum; and, therefore, the longer the latter the greater the range over which the magnifying power will be practically constant. A pendulum whose period is 30 seconds and which is damped in this ratio will give a very correct record of the relative amplitudes in all parts of the seismogram; for waves having a longer period than this are not very frequent.

*Magnifying power for short periods.* — Among the instruments which recorded the California earthquake magnifying powers for very short periods of 2 or 3, 6 or 7, 10, 15, 25, 100, and more, are found. The majority of those with low magnifying powers gave unsatisfactory determinations of the beginning of the shock, even at stations less than 90° distant; and for greater distances than this the beginning in general was not recorded at all. We have been unable to determine the time of the arrival of the beginning of the shock at the very distant stations, as they are all provided with low magnifying instruments. This is most unfortunate, for it is true not only in the case of the California earthquake but of all other shocks whose times and origins are accurately known; and therefore our knowledge of the velocity of propagation to very great distances is still quite vague. To get satisfactory records of earthquakes at distances more than 100° it is necessary to have instruments with magnifying powers of at least 100.

*Time scale.* — A great variety of time scales were used, from 1 mm. to the minute, or even less, up to 15 mm. to the minute; and in one case, at Göttingen, the scale was 60 mm. to the minute. The advantage of the open time scale is that individual vibrations are recorded, making it possible to determine their period and the magnifying power of the instrument for them; and the characteristics of the motion can be seen. This can not be done on seismograms with small time scales. On the other hand, when the movement begins very gently it is extremely difficult, on the open time scale, to determine where the slight waves in the line begin; but they would appear much more clearly on seismograms with small time scales. Wherever the magnifying power is sufficiently great there is no difficulty in determining the time of the beginning, and the advantage of a time scale of 10 or 15 mm. to the minute, in permitting the period of the vibration to be determined, is very great.

*Identification of the phases on the seismograms.* — The seismograms made by different instruments differ greatly among themselves, and it is very often extremely difficult to decide exactly where a particular phase begins. Where the magnifying power is sufficiently large this difficulty is not serious for the first and second preliminary tremors, but it often is for the regular waves and the subsequent phases. Where the magnifying power is small there is great difficulty in deciding upon the time of the beginning of the first preliminary tremors. It is therefore of very great importance, in studying the propagation of an earthquake disturbance, to have copies of the seismograms themselves, and not merely the recorded times as determined by the directors in charge of the instruments. For without doubt, different persons examining single seismograms, without comparison with others, would frequently take different parts of the movement to represent the beginning of a particular phase.



APPENDIX  
THEORY OF THE SEISMOGRAPH



## THEOEY OF THE SEISMOGRAPH.

### INTRODUCTION.

IN the early development of seismographs the attempt was made to produce a "steady point"; that is, a point that will remain at rest when the earth is set in motion by an earthquake. If then the relative motion of the "steady point" and the earth were recorded, we should have the actual movement of the earth. The "steady point" must be supported against gravity, and therefore all seismographs must consist of a support connected with the earth and moving with it, and a mass, held up by the support in such a manner that it will partake as slightly as possible of the latter's movements; let us call this portion the "pendulum." We must also have a method of recording the motion of the pendulum relative to the support. If the pendulum were exactly in neutral equilibrium for any movement of the support, we should have a truly "steady point," but this can not be realized; a movement of the support exerts forces on the pendulum which set it in motion, and the problem therefore presents itself: to determine the actual movement of the support from the movement of the pendulum relative to the support. The only possible way to do this is to analyze this relative movement, and thru the laws of mechanics work out the movement of the support. We must therefore develop the mechanical theory of the instrument.

Let us first note that all movements can be broken up into a displacement and a rotation; and these can be resolved into three component displacements parallel to three axes at right angles to each other, and three rotations around these axes; and therefore the instruments must be made to record the three displacements and the three rotations in order completely to determine the movement. We shall see that instruments have not been made which will be only affected by one component of the motion, but in many cases the other components may be relatively so unimportant that they may be neglected; or by means of several instruments, we can, by elimination, determine the several components. Earthquake disturbances are propagated as elastic waves of compression or distortion; and even at a very short distance from the origin, the movements of the earth-particles are vibrations about their positions of equilibrium. Surface-waves also exist, in the propagation of which gravity does not play a part.

In the immediate neighborhood of severe earthquakes the vibratory displacements maybe measured by centimeters, but at a distance of 1,000 km. or more the displacements are of the order of millimeters, a displacement of 5 mm. being a very large one; and the horizontal and vertical displacements are of the same general' order. Up to the present our instruments have not separated the linear displacements from the rotations, but we can calculate what the rotations should be with given linear displacements, as follows.

### ROTATIONS DUE TO EARTH WAVES.

Let us first take the case of a simple harmonic wave where the movement of the particles is transverse to the direction of propagation; the equation is

$$y = A \sin 2\pi(j^{\wedge}-ft) \quad (1)$$

$t$ ,

where

$y$  is the variable displacement of the earth particles,  
 $A$  the maximum displacement or amplitude,  
 $t$  the time,  
 $x$  the distance along the direction of propagation,  
 $P$  the period of vibration,  
 $\lambda$  the wave length.

This represents a wave traveling in the positive direction of  $x$ ; the displacement  $y$  may be in any direction perpendicular to  $x$ , and in general it may be broken up into vertical and horizontal components. In figure 32, let  $x$  be the direction of propagation, and  $y$  may be

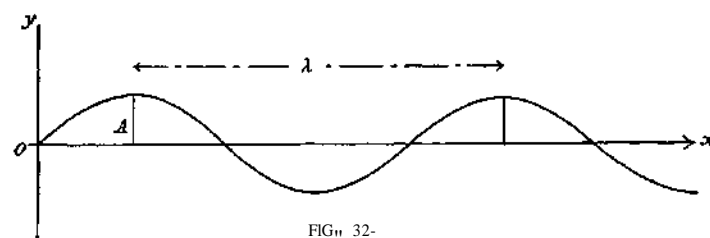

FIG. 32.

either vertical or horizontal; since all the earth particles move parallel to  $y$ , a line in this direction is not rotated at all; whereas a line parallel to  $x$  is made to assume the wave form, and its elements experience the maximum rotation. The tangent of the angle which an element of the line makes with the axis of  $x$  is given by the difference in the displacements of two neighboring points divided by their distance apart, *i.e.*, by  $dy/dx$ ; but

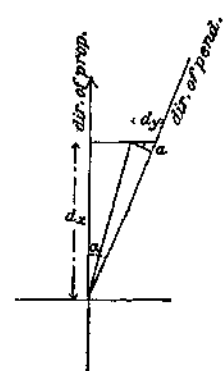

FIG. 33.

$$\frac{dy}{dx} = 2\pi \frac{A}{\lambda} \cos 2\pi \left( \frac{t}{P} - \frac{x}{\lambda} \right) \quad (2)$$

and its maximum value is  $2\pi A/\lambda$ . If  $v$  is the velocity of propagation,  $\lambda = vP$ . The waves of largest amplitude have a velocity of about 3.3 km. per second, and a period of 15 to 20 seconds; and hence a wave length of from 50 to 66 km. If we take  $A = 5$  mm., which is a very large amplitude, and  $\lambda = 66$  km., we find  $2\pi A/\lambda = 6.3 \times 5/66 \times 10^8 =$  about  $5 \times 10^{-7}$  or one-tenth sec. arc. As small as this angle is, the most sensitive instruments are capable of measuring it, provided the rotation is around a horizontal and not the vertical axis. If two horizontal pendulums were supported by the

solid rock and placed one with the beam pointing in the direction of the propagation of the wave, and the other at right angles to it, then if the displacements were horizontal, that is, if the rotation was around a vertical axis, the first pendulum would suffer a slight relative rotation, but the second one would not. If, however, the displacements were vertical, and the rotation around a horizontal axis, the second pendulum would be displaced and the first would not.

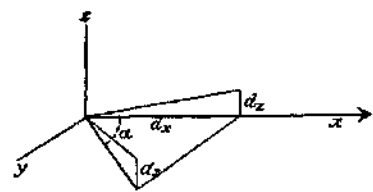

FIG. 34.

In the more general case where the direction of propagation makes an angle  $a$  with the direction of the horizontal pendulum we find the relative rotation of the pendulum for horizontal displacements to be  $\cos^2 a \cdot dy/dx$ , obtained by dividing  $\cos a \cdot dy$  by the length of the line; *i.e.*, by  $dx/\cos a$ , as shown in figure 33. If we had a second pendulum at right angles to the first, the amount of its relative rotation would be  $\sin^2 a \cdot dy/dx$ , and the direction of the 2 rotations would always be the same. In the case of vertical displacements the rotation of a horizontal line making an angle  $a$  with the direction of

propagation is  $\cos \alpha \cdot dy/dx$ , as will readily appear from figure 34. A line making a vertical angle  $\alpha$  with the horizontal direction of propagation would be turned thru an angle  $\cos^2 \alpha \cdot dy/dx$ , but this line does not interest us, nor does the corresponding line in the case of horizontal displacements, which would have a rotation of  $\cos \alpha \cdot dy/dx$ .

These conclusions depend on the assumption that the support of the seismographs has exactly the same motion as the underlying rock, or that the column supporting the pendulum is fastened rigidly to the rock; if, however, the seismograph rests on a pier, even tho it be connected rigidly with the solid rock, the case is different. The movement is communicated to the base of the pier, and as its sides are subjected to no constraining forces, the top of the pier, in the case of horizontal displacements, would probably rotate around a vertical axis nearly like a rigid body, thru an angle equal to the average rotation of all lines in its base; that is, thru an angle  $\bar{\mu}$ , such that

$$\bar{\mu} = \frac{1}{A} \int_0^{2\pi} \frac{2\pi A}{\lambda} \cos^2 \alpha \cdot d\alpha = \frac{1}{2} \frac{2\pi A}{A} \quad (3)$$

or half the maximum rotation in the solid rock. We assume that the natural period of the pier for rotational vibrations is so much shorter than the period of the earthquake wave that it does not exert an appreciable influence on the amount of the rotation; this assumption seems entirely justified.

In the case of vertical displacements the pier would be tilted thru an angle equal to the tilt of the rock, but its top would also have quite a large linear displacement. If, however, the pier were very long, its period might be comparable to that of the shorter earthquake waves, and the instrument would record movements which would be a combination of the movements of the ground with the proper movements of the pier. It is probable that the movements of high chimneys and tall buildings would be materially affected by their natural periods of vibration.

Let us now consider waves of condensation, like sound waves, where the direction of the displacement,  $f$ , is the same as that of propagation,  $x$ ; the equation of the wave will still have the same form as heretofore. A line in the direction of propagation or at right angles to it, horizontal or vertical, will have no rotation; a horizontal line making an angle  $\alpha$  with  $x$  will suffer a difference of displacement of its two ends equal to  $d\delta \sin \alpha$ , or  $d\delta \cos \alpha$  at right angles to its length; its length is  $dx/\cos \alpha$ ; therefore its rotation is  $\sin \alpha \cos \alpha \cdot dg/dx$ ; the maximum value of this is  $rrA/x$ , when  $\alpha = 45^\circ$  and when  $dg/dx$  is a maximum. This is a rotation around the vertical axis. A line making an angle  $\alpha$  on the opposite side of the line of propagation is rotated in the opposite direction; it is probable that the top of the pier would not rotate at all about the vertical, when the base is subjected to this kind of motion. Observers have not so far succeeded in directly measuring rotations; and as we should expect them to be extremely small, we shall so consider them until further evidence shows them to be larger.

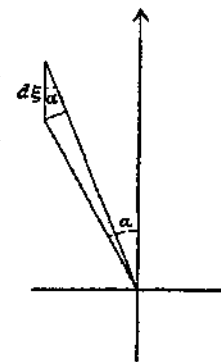

FIG. 35.

#### FORMS OF SEISMOGRAPHS.

The forms of instruments which have proved practical for recording very small disturbances are: the ordinary pendulum, the horizontal pendulum, and the inverted pendulum. The first form is too familiar to need any explanation; the second is a frame or a bar carrying a heavy mass, supported at two points nearly in a vertical line, as a door is supported by its hinges; so that its position is affected by a small displacement of the support at right angles to the direction toward which it points; the inverted pendu-

lum is a heavy mass whose center of gravity is vertically above the point of support; some additional forces must be applied in order to keep it in stable equilibrium in this position; these forces are usually supplied by springs connecting the upper part of the mass and the support.

#### REGISTRATION.

There are two principal methods of magnifying and registering the relative movements, the photographic and the mechanical. It is to be noticed that these relative movements are all of the nature of rotations of the pendulum about a point or a line of the support. The photographic method of registering may be divided into two kinds, the optical and the direct. In the optical method a beam of light from a stationary point is reflected from a mirror on the pendulum and concentrated on a moving sheet of photographic paper which is afterwards developed. Time marks are made by periodically eclipsing the light. The magnifying power depends on the distance of the recording paper from the mirror. In the direct method the light is reflected through a longitudinal slit in a diaphragm on the end of the pendulum's beam and a transverse slit in the top of a box, to the moving photographic paper below. As long as the pendulum is still, a straight line is recorded on the paper, but when the pendulum swings, the line is shifted from side to side. The magnifying power depends on the ratio of the length of the beam to the distance of the center of oscillation from the axis of rotation. In the mechanical method of registering the record is made by a pen on white paper or by a stylus on smoked paper. The marking point may be fastened directly to the pendulum or may be connected with it thru one or more multiplying levers.<sup>1</sup>

#### THE MATHEMATICAL THEORY.

The mathematical theory of seismographs has been written by Dr. W. Schliiter,<sup>2</sup> E. Wiechert,<sup>3</sup> Prince B. Galitzin,<sup>4</sup> Gen. H. Pomerantzeff,<sup>5</sup> Professor O. Backlund,<sup>6</sup> Dr. M. Contarini,<sup>7</sup> and Dr. M. P. Rudski,<sup>8</sup> but up to the present the general theory has not been written in English. Messrs. Perry and Ayrton, however, published an important paper in 1879,<sup>9</sup> in which they developed the mathematical theory of a heavy mass suspended by springs in a box supposed to move with the earth. They emphasized the fact that the actual motion of the mass is made up of that of the earth and of its proper vibration; they showed the influence of damping and the relation between the relative movement and the motion of the earth. This paper seems to have been overlooked and is not referred to by later writers on the theory.

<sup>1</sup> It is not desirable here to give details of construction. They will be found in Milne's Earthquakes and Seismology; in Button's Earthquakes, in Sieberg's Erdbebenkunde, and in the original descriptions in memoirs of scientific societies. Dr. It. Ehlert describes many forms of instruments in Gerland's Beiträge zur Geophysik, 189(5-1898, vol. III, pp. 350-475.

<sup>2</sup> Schwingungsart und Weg der Erdbebenwellen. Gerland's Beiträge zur Geophysik, 1903, vol. V, pp. 314-36U, 401-466.

<sup>3</sup> Theorie der automatischen Seismographen. Abhand. Kön. Gesells. Wissen. Göttingen, Math. Phys. Kl. 1902-1903, Bd. II, pp. 1-128.

<sup>4</sup> Ueber Seismometrische Beobachtungen. Acad. Imp. Sciences. St. Petersburg, 1902. Comptes Rendus Commission Seismique Permanente. Liv. 1, pp. 101-183. Zur Methodik der Seismometrischen Beobachtungen. Same, 1903. T. I. Liv. 3, pp. 1-112. Ueber die Methode zur Beobachtungen von Neigungswellen. Same, 1905, T. II. Liv. 2, pp. 1-144. Die Electromagnetische Itcgistrirmethode, Same, 1907, T. III. Liv. 1, pp. 1-106.

<sup>5</sup> In Russian, Same, pp. 185-208.

<sup>6</sup> Formeln für das Horizontalpendel. Same, pp. 210-213.

<sup>7</sup> Rend. d. R. Acad. d. Linn. Cl. Sc. iis. math. e. nat., 1903, vol. XII, pp. 507-515, 609-616.

<sup>8</sup> Ueber die Bewetmng des Horizontalpendels. Gerland's Beiträge zur Geophysik, 1904, vol. VI, pp. 138-155.

<sup>9</sup> On a Neglected Principle that may be employed in Earthquake Measurements. Phil. Mag., 1879, vol. VIII, pp. 30-50.

Dr. Schliiter's work was undertaken to determine if the movements of seismographs due to distant earthquakes were caused by linear displacements or by tilts; and he develops the theory for these two kinds of motion separately. He discusses the effect of damping and shows the relation between the movement of the earth and that of the seismograph.

Professor Wiechert begins by giving the theory of the ordinary pendulum in a very simple way, which does not, however, show the degree of approximation made; he then develops the general theory of seismographs without considering specifically the characteristics of each form. An extremely valuable part of the memoir is the study of the solid and viscous friction and their influence on the movement of the pendulums; also the relation between the amplitude of the pendulum relative to the support and the amplitude of the support, when the latter is moving in a simple harmonic vibration, for various values of the ratio of the period of vibration of the support and the natural period of the pendulum, and for various degrees of damping.

Prince Galitzin treats many forms of seismographs with considerable fullness. He develops the equations through Lagrange's equations and shows what terms are neglected and the degree of approximation secured. The physical origin of certain terms in his equations are not evident, and he treats his pendulums as mathematical pendulums, that is, as though the mass were concentrated at the center of oscillation; certain terms which contain the moment of inertia about the center of gravity do not appear in his equations; this is unimportant as they are in general negligible. Prince Galitzin has also developed a method of electromagnetic recording, and has given the theory of the instrument. This instrument offers some special advantages, but it has not yet come into general use. An important part of Prince Galitzin's work consists of an experimental verification of the theory by means of a moving platform, which imitates the movements produced by distant earthquakes.

Professor Backlund starts from Euler's equation and obtains the equation of the horizontal pendulum under disturbance, but he does not consider either viscous or solid friction.

Dr. M. Contarini treats the seismograph as a series of connected links, and develops the theory in symbolic form.

Dr. Rudski develops the equations of the horizontal pendulum through Lagrange's equations, retaining quantities of the second order. Under these conditions he finds that in the case of periodic movements of the ground, the terms containing the damped free period of the pendulum are no longer periodic. In cases where the damping is large or the movement of the pendulum small, this peculiarity is unimportant.

In the following pages we shall develop the equations of relative motion of the pendulum from the two fundamental laws; namely, the motion of the center of gravity, and Euler's equations for angular accelerations about moving axes. We shall see the order of the terms neglected, and the physical origin of the terms in our resulting equations will be evident. We shall begin with the horizontal pendulum, as the lever used for magnifying the motion with ordinary mechanical registration is itself a horizontal pendulum and the equation of its motion must supply terms in our resultant equations. We shall also assume an arbitrary position for the origin of coördinates, and determine what position of this origin will give the simplest equation; we shall find this to be the center of gravity of the pendulum in its undisturbed position. Although I have followed a different route in developing the equation of the seismograph from those followed by the investigators mentioned, I wish to acknowledge my indebtedness to them for the guidance I have received from **their** researches.





- $i$ , the inclination during the disturbance;  
 $\theta$ , the angular displacement of the  $CG$  relative to the support, the positive direction being the same as that of  $a_{>z}$ ;  
 $l$ , the perpendicular distance from the  $CG$  to the axis of rotation at  $0'$ ;  
 $X, Y, Z$ , the absolute coördinates of  $0'$  before the disturbance;  
 $x, y, z$ , the absolute coördinates of the  $CG$  at any time;  
 $F$ , the force applied at  $0'$ ;  
 $F_x, F_y, F_z$  } its components parallel to the fixed axes and to the moving axes, respectively.  
 $F_1, F_2, F_3$  }  
 $f_x, f_y, f_z$  } the components of the force exerted on the pendulum by the indicator;  
 $f_1, f_2, f_3$  }  
 $M$ , the mass of the pendulum;  
 $I_1, I_2, I_3$ , the moments of inertia of the pendulum about the principal axes of inertia through the  $CG$ ;  
 $\xi, \nu, \zeta$ , the linear displacements of the support due to the disturbance;  
 $\alpha_x, \alpha_y, \alpha_z$  } the angular displacements around the axes, due to the disturbance, the positive directions being indicated in the figure.  
 $\alpha_v, \alpha_w, \alpha_s$  }

For the sake of clearness the displacements of the support are not shown in the figure, but they can easily be imagined.

The linear accelerations of the  $CG$  are given by the equations

$$M \ddot{x} = F_x + f_x \quad M \ddot{y} = F_y + f_y \quad M \ddot{z} = F_z - Mg \quad (4)$$

In order to see exactly what approximations we make, we must use Euler's equations for moving axes to determine the angular accelerations; the motion is referred to the instantaneous position of the 3 principal axes of inertia thru the  $CG$ , which we have called (1) (2) and (3) respectively; as we only observe the rotation around (3) we may neglect the equations referring to the other axes; the equation is

$$I_3 \frac{d^2 \mu}{dt^2} - (I_1 - I_2) \frac{d\omega_1}{dt} \frac{d\omega_2}{dt} = C_3 \quad (5)$$

where  $p$  is the absolute angular acceleration around the instantaneous position of the axis (3), and  $C_3$  is the moment of all forces around this axis. As the pendulum has no relative motion around the axes (1) and (2), its angular velocities around their instantaneous positions are the same as those of the support. Since the support is supposed to move with the underlying rock, its angular displacement will be the same as that of the rock, and will be given by equation (2). Its angular velocity will be obtained by differentiating this equation with respect to the time, we thus find:

$$\frac{d\omega_1}{dt} (\max) = \frac{(2\pi)^2 A}{\lambda P} \quad (6)$$

and with the values there used:  $A = 5$  mm.,  $P = 20$  sees.;  $X^* = 66$  km., this becomes about  $3 \times 10^{-7}$ ; and  $d < o < Jdt$  has a value of the same order. We may write (as we shall see further on)

$$\mu = \odot \cos \left( \frac{2\pi}{P} t \right); \quad \frac{d^2 \mu}{dt^2} (\max) = \left( \frac{2\pi}{P} \right)^2 \odot \quad (7)$$

making  $P = 20$  sees, and  $\odot = 0.005$ , which is probably a smaller value than it would have under the assumed disturbance, we find the maximum value of the relative angular acceleration of the pendulum to be about  $5 \times 10^{-4}$ , a quantity far larger than the product of the two angular velocities given above. We may, therefore, without appreciable error, neglect the second term of equation (5).

The reactions of the support have been replaced by a single force  $F$  applied at  $O'$  and a couple. The forces of the couple both pass thru the axis of rotation and therefore can not have a component around it, or around a parallel axis thru the  $CG$ . Of the components of  $F$ ,  $F\%$  passes through the  $CG$ ;  $F_3$  is parallel with (3), and therefore  $F_x$  alone is capable of exerting a moment around (3). Similarly only the  $f_x$  component of / can exert a moment around (3). If the latter force is exerted at a point distant  $l_x$  from  $O'$ , we find

$$C_s = F_l l - f_l(l_1 - l) \quad (8)$$

Let us replace  $d^2\dot{f}_i$  by  $d^2(6 + a_g)$ , which expresses the angular acceleration in terms of the acceleration of the pendulum relative to the support, and the acceleration of the support; with these substitutions the equation of angular acceleration (5) becomes

$$I_1 \frac{d^2(\theta + \omega_s)}{dt^2} = F_l - f_l(l_1 - l) \quad (9)$$

We must now replace  $F_l$  by its value in terms of the resolved parts of  $F_x$ ,  $F_y$ ,  $F_z$  in the direction of (1), and then the values of these latter quantities must be obtained from equation (4).

We have

$$F_l = F_x \cos(x, 1) + F_y \cos(y, 1) + F_z \cos(z, 1) \quad (10)$$

Since the rotations are the same for all points, we can determine the cosines of the angles in the above equation, by assuming a sphere of unit radius with center at  $O'$ , and determining the displacements of the axes on its surface as a result of the rotations ( $\omega$ 's) and the relative angular displacement ( $\theta$ ). These values follow directly from figure ^7, where the points represent the intersections of the axes with the surface of the sphere and the lines represent the displacements of these points.

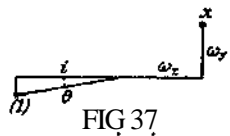

FIG 37

$$\begin{aligned} \cos(x, 1) &= \cos(\omega_x + \theta) = 1 - \frac{\omega_x^2}{2} \\ \cos(y, 1) &= \sin \left\{ \omega_y + \theta \left( 1 - \frac{\omega_x^2}{2} \right) \right\} = \omega_y + \theta \\ \cos(z, 1) &= -\sin(\omega_z + \theta) = -(\omega_z + \theta) \end{aligned} \quad (11)$$

All the angles are small, and  $i$  and  $\theta$  are considerably larger than the  $\omega$ 's; we have therefore neglected squares of the  $\omega$ 's, products of  $\omega$ 's and  $\theta$ , and  $\theta^2$ ; but  $i\theta$  is an important term in our equation; and since  $\theta^2$  is of the same order, these terms must be retained.

Substituting the values of these cosines and the values of  $F_x$ ,  $F_y$ ,  $F_z$  from equations (4), in equation (10) we get

$$F_l = \left( M \frac{d^2 x}{dt^2} - f_x \right) \left( 1 - \frac{\omega_x^2}{2} \right) + \left( M \frac{d^2 y}{dt^2} - f_y \right) (\omega_y + \theta) - \left( M \frac{d^2 z}{dt^2} + Mg \right) (\omega_z + \theta) \quad (12)$$

The coordinates of  $CG_0$  are  $X$ ,  $Y+l$ ,  $Z-il$ ; the coordinates of  $CG_S$ , during the disturbance, are

$$\begin{aligned} X &= X + A + (Z - il) \omega_x - (Y + l) \omega_y \\ Y &= Y + l + X \omega_x - (Z - il) \omega_y \\ Z &= Z - il + (Y + l) \omega_x - X \omega_y \end{aligned} \quad (13)$$

and the coordinates of  $CG$  during the disturbance are

$$\begin{aligned} x &= X + X + (Z - H) \omega_x - (Y + l) \omega_y - i\theta \\ y &= Y + l + X \omega_x - (Z - il) \omega_y \\ z &= Z - il + (Y + l) \omega_x - X \omega_y \end{aligned} \quad (14)$$

The rotations are so small that we may neglect the order in which they are effected, and their coefficients may be considered constants. Differentiating, we get

$$\begin{aligned} \frac{d^2x}{dt^2} - \frac{d^2\epsilon}{dt^2} &= (Y+il) \frac{d^2\omega_x}{dt^2} - \frac{d^2P}{dt^2} \\ \frac{d^2y}{dt^2} &= \frac{d^2\eta}{dt^2} + X \frac{d^2\omega_x}{dt^2} - (Z-il) \frac{d^2\omega_z}{dt^2} \\ \frac{d^2z}{dt^2} &= \frac{d^2\xi}{dt^2} + (Y+il) \frac{d^2\omega_x}{dt^2} - X \frac{d^2\omega_z}{dt^2} + g \end{aligned} \quad (15)$$

Introducing these values in equation (12), and the value of  $F_x$  thus obtained in equation (9) and writing  $I_8 + Ml^2 = I_{(3)}$ , the moment inertia around the axis of rotation, we get,

$$\begin{aligned} I_{(3)} \frac{d^2\theta}{dt^2} + I_8 \frac{d^2\omega_3}{dt^2} &= Ml \left[ \left\{ \frac{d^2\xi}{dt^2} + (Z-il) \frac{d^2\omega_x}{dt^2} - (Y+il) \frac{d^2\omega_z}{dt^2} - \frac{f_z l_1}{Ml} \right\} \left(1 - \frac{\theta^2}{2}\right) \right. \\ &\quad + \left. \left\{ \frac{d^2\eta}{dt^2} + X \frac{d^2\omega_x}{dt^2} - (Z-il) \frac{d^2\omega_z}{dt^2} \right\} (\omega_x + \theta) \right. \\ &\quad \left. - \left\{ \frac{d^2\xi}{dt^2} + (Y+il) \frac{d^2\omega_x}{dt^2} - X \frac{d^2\omega_z}{dt^2} + g \right\} i \left( \frac{\omega_x}{i} + \theta \right) \right] \end{aligned} \quad (16)$$

The force  $f_z$  is small; and on account of friction between the pendulum and the indicator, its direction is not accurately known, but as the friction and the angular displacements are small, it is nearly at right angles to both the pendulum and the indicator; we have therefore replaced  $f_i$  in equation (9) by  $f_x (1 - \theta^2/2)$  and have neglected the term  $f_y (\omega_y + \theta)$  in obtaining equation (16). This is the general equation of the horizontal pendulum seismograph, within the approximations mentioned. The successive lines of the second member give the moments around the axis (3) due to forces parallel to the axes of  $x$ ,  $y$ , and  $z$  respectively; (the term  $MPd^2B/dt^2$ , which has been combined in the first term of the first member, should be restored to the first line of the second member to make the statement strictly true) and the origin of the force represented by each term in the equation is evident.

This equation can be greatly simplified by a proper choice of the origin of coördinates; if we place the origin at  $O'$ , we have  $X = Y = Z = 0$ , and the equation becomes

$$\begin{aligned} I_{(3)} \frac{d^2\theta}{dt^2} + I_8 \frac{d^2\omega_3}{dt^2} &= Ml \left[ \left\{ \frac{d^2\xi}{dt^2} - il \frac{d^2\omega_x}{dt^2} + l \frac{d^2\omega_z}{dt^2} - \frac{f_z l_1}{Ml} \right\} \left(1 - \frac{\theta^2}{2}\right) \right. \\ &\quad \left. + \left\{ \frac{d^2\eta}{dt^2} + il \frac{d^2\omega_x}{dt^2} \right\} (\omega_x + \theta) - \left\{ \frac{d^2\xi}{dt^2} + l \frac{d^2\omega_z}{dt^2} + g \right\} i \left( \frac{\omega_x}{i} + \theta \right) \right] \end{aligned} \quad (17)$$

On putting  $l_8 = 0$ , omitting  $\theta^2/2$ ,  $f_z l_1$  and  $l \frac{d^2\omega_z}{dt^2}$ , and making the proper changes of notation, this becomes the equation No. 86 of Prince Galitzin.<sup>1</sup> Equation (16) can be simplified still more by placing the origin at  $CG_Q$ ; then  $X = Y + l = Z - il = 0$ , and it becomes

$$I_{(3)} \frac{d^2\theta}{dt^2} + I_8 \frac{d^2\omega_3}{dt^2} = Ml \left[ \left( \frac{d^2\xi}{dt^2} - \frac{f_z l_1}{Ml} \right) \left(1 - \frac{\theta^2}{2}\right) + \frac{d^2\eta}{dt^2} (\omega_x + \theta) - \left( \frac{d^2\xi}{dt^2} + g \right) i \left( \frac{\omega_x}{i} + \theta \right) \right] \quad (18)$$

It is evident that this equation can not be simplified further without omitting some of its terms. Referring to the equation of a wave, equation (1); differentiating twice with respect to  $t$  we find for the maximum value of the acceleration

$$\frac{d^2\eta}{dt^2} (max) = \left( \frac{2\pi}{P} \right)^2 A \quad (19)$$

<sup>1</sup> Ueber Seismom. Beobachtungen.. Acad. Imp. d. Sci. St. Petersburg. G. R. Com. Sisraique Perma-  
nent©. 1902, Liv. I, p. 142.

with  $P = 20$  sees, and  $.4 = 5$  mm., this has a value of about 0.5 mm. per sec. per sec. This is the order of the terms  $d^2\theta/dt^2$ ,  $d^2v/dt^2$ ,  $d^2\omega/dt^2$ ; the last is very small in comparison with  $g$ , which is nearly 10,000 mm. per sec. per sec., and may therefore be neglected.  $\theta^2/2$  is small in comparison with unity, but it is of the same order as  $id$  nevertheless  $d^2i/dt^2$  is so small in comparison with  $g$ , that we may neglect  $(\theta^2/2)(d^2i/dt^2)$  also;  $d^2v/dt^2$  is of the same order as  $d^2Z/dt^2$ , but it is multiplied by  $(\omega^2/6)$ , which with some instruments may amount to  $1/6$ ; if the accuracy of our measures is not greater than this, we may omit this term in comparison with  $d^2i/dt^2$ . The product  $f_x(1 - \theta^2/2) = f_y$ . The left-hand member of the equation may be written  $MPd^2d/dt^2 - I_s(d^2\theta/dt^2 - d^2\cos\theta/dt^2)$ ; the omission of  $d^2a/dt^2$  is equivalent to substituting, in the second term, the angular acceleration relative to the support for the absolute angular acceleration. Since the maximum value of  $\omega$  is of the order of  $5 \times 10^{-7}$  and the maximum value of  $\theta$  is of the order of  $5 \times 10^{-3}$ , and since they would have the same period, we find that  $d^2d/dt^2$  would be about 1,000 times as large as  $d^2a/dt^2$ ; and since in general  $I_s$  is much smaller than  $MP$ , it is clear that we make no material mistake in omitting  $d^2a/dt^2$ . Our equation then takes the form

$$I_s \frac{d^2\theta}{dt^2} = Ml \left[ \frac{d^2\xi}{dt^2} - \frac{f_x l}{Ml} - gi \left( \frac{\omega}{i} + \theta \right) \right] \quad (20)$$

In the undisturbed condition the  $CG$  lies in the vertical plane containing the axis of rotation, this axis making a small angle  $i_0$  with the vertical. When the instrument is disturbed the position of equilibrium is in the vertical plane containing the axis of rotation in its disturbed position. Using the same device as on page 152, we see by figure 38

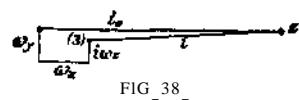

FIG. 38.

that the angle thru which the plane of equilibrium is turned is  $-(a_y - i\omega_z)/i$ ; but since the support itself is turned about the vertical thru an angle  $a_x$ , the angular displacement of the plane of equilibrium relative to the support is  $-(\omega_z - i\omega_x)/i - a_x$ , which reduces to  $-a_x/i$ . The last term in equation (20) is therefore the moment due to gravity tending to bring the pendulum back to its position of equilibrium, and it is proportional to the angular displacement from the position of equilibrium.

The value of the new angle  $i$ , between the vertical and the axis of rotation, reduces practically to  $i_0 - a_x$ , on account of the small angle thru which the plane of equilibrium has been rotated (see figure 38). Since  $\omega_x$  is of the order  $5 \times 10^{-7}$  and  $i_0$  for the von Rebeur pendulum, where it has a smaller value than for any other instrument, is about 1:700, we see that its value is about  $i:500Q$ ; for other instruments it is still smaller; we may omit  $a_x$  and consider that the inclination of the axis of rotation to the vertical has not been changed by the disturbance.

The equation contains  $f_x l$ , the moment due to the reaction between the pendulum and the indicator. Its value can be determined from the equation of the indicator and then substituted in equation (20). The indicator is itself a small, horizontal pendulum and is affected by the disturbance; its general equation will be of the form of equation (16). Let us assume that the axis of rotation of the indicator and its  $cg_0$  lie in the axis of  $y$  thru the  $CG_0$  of the pendulum; the coördinates of the  $cg_0$  then become 0,  $l$ , 0 (see fig. 36); putting these values for  $X$ ,  $Y + l$ ,  $Z - il$ , in equation (16) and writing primes to mark the quantities referring to the indicator, its equation becomes

$$I_s' \frac{d^2\theta'}{dt^2} + I_s' \frac{d^2\omega_z'}{dt^2} = M'l \left[ \frac{d^2\xi'}{dt^2} - \frac{f_x' l}{M'l} + \frac{d^2\eta'}{dt^2} (\omega_z + \theta') - \left( \frac{d^2\xi'}{dt^2} + l_4 \frac{d^2\omega_z'}{dt^2} + g \right) \omega_y' \right] \quad (21)$$

// has a positive sign because the force is applied so that a positive force causes a positive angular acceleration; we have assumed  $i = 0$ , and that the reaction between the

indicator and the pendulum acts at right angles to the former and is equal to its (1) component. These assumptions will not be accurately true, but the quantities involved are small, and no important error will be introduced by them. Even in this form the equation is very complicated, but it can be made very simple by constructing the indicator so that its *eg* shall lie in its axis of rotation, then  $V$  becomes 0, and only one term remains on the right-hand side. In this case  $I_{(s)'} = I_s'$ ; but  $\delta'$  is several times as large as  $\theta$ , so that as shown on page 154 we may omit  $\frac{1}{3} \delta'^2 (a/c \&^2)$ , and the equation of the indicator takes the simple form

$$V^{\wedge} = I A \quad (22)$$

With the *eg* in the axis of rotation it makes no difference where this axis is situated, and the indicator may even be a bent lever without changing its equation; this method of reducing the influence of the indicator is so simple that it should always be followed. In this paper we shall assume that it has been; if it has not we must either take into account the various terms of equation (21) or we must look upon them as unimportant and neglect them.

We have, of course,  $f_i' = -f_i$ ; also  $\delta' = -n_x \delta$ , where  $n^{\wedge} l_j l^{\wedge}$ , and hence  $\delta d/d\delta = -n^{\wedge} \theta/dt^2$ ; eliminating  $f_x$  from equation (20) by means of equation (22), and making the above substitutions, we get

$$(I_{(s)} + n_1^2 I_3') \ddot{\theta} + \left[ \xi - \frac{\omega_x}{i} + \delta \right] \dot{\theta} = 0 \quad (23)$$

It will be seen that the moment of inertia of the pendulum is practically increased by  $n_x^2$  times the moment of inertia of the indicator, and this tends to diminish the angular acceleration; whereas the mass of the pendulum which appears on the right side of the equation and tends to increase the acceleration is not affected by the indicator; hence the importance of making the indicator as light as possible. If for the sake of increasing the magnifying power of the pendulum we should add a second lever to be deflected by the first, and if the ratio of the angular deflections of the second and first levers be  $n_v$ , then the effective moment of inertia of the two levers is  $7_{(3)'} + n \ell l_m''$ , and that of the whole system is  $7_{(8)} + w_1^2 / (8)' + n^2 2 l_m''$ . The magnifying power may be increased by a multiplication of levers, the actual deflections of the pendulum are diminished and it may be materially. In the Bosch-Omori 10 kilog. seismograph  $7_{(3)} = 61.6 \times 10^6$  cm.<sup>2</sup>gm.;  $7_{(3)'} = 280$  cm.<sup>2</sup>gm.; and when the magnifying power is 10,  $w_x = 31.3$ ; hence the effective moment of inertia added by the indicator,  $n^{\wedge} I_d'$  equals  $27.5 \times 10^4$ , or  $\frac{1}{225}$ th of  $7_{(3)}$ .

Let us write  $7_{(3)} + n^{\wedge} I_d' = n^{\wedge} n_2^2 I_{(s)''}$  . . . = [7]; also  $[I]/Mt = L$ ; introducing these substitutions in the equation (23) we get

$$\frac{d^2 \theta}{dt^2} + \frac{1}{L} \frac{d \xi}{dt} + \frac{g i}{L} \left( \frac{\omega_x}{i} + \theta \right) = 0 \quad (24)$$

We have so far not taken account of friction; but all instruments are subjected both to viscous friction, or damping, proportional and opposite to the velocity, and to solid friction, which has a constant quantitative value, but always opposes the motion; in some cases, special devices are added to increase the damping. Writing  $2 \tau cd \theta/dt$  to represent the damping and  $T p_0$  for the solid friction, the equation becomes

$$f \ddot{\theta} + 2 \tau c f \dot{\theta} + f (\wedge + e W \theta) = 0 \quad (28)$$

We here assume that the damping is proportional to the velocity relative to the support. This is true where special damping devices are affixed to the support, but in the case

where no special damping is introduced, the viscous friction is largely due to the resistance of the surrounding air, and if this does not move with the support, it will not be proportional to the *relative* velocity, but to some complicated function of the relative and absolute velocities. If the instrument is in a closed room, and the earthquake motion not fast, the air will, to some extent, move with the support, and as the damping, when special devices are not used, is extremely small, we make no material error in putting it proportional to the *relative* velocity.

$\delta$  in the equation refers to the relative angular displacement of the pendulum; if we prefer to deal directly with the relative displacement of the marking point, we can proceed as follows: let  $l$  be the length of the long arm of the last or marking lever, and  $\bar{\delta}$  its angular displacement; multiply the equation (25) throughout by  $\bar{n}l$ , where  $\bar{n} = \frac{71}{1} \cdot 2^{n-3} \cdot \dots$ . If  $a$  is the linear relative displacement of the marking point  $a = \bar{l}\bar{\delta} = \bar{n}l\delta$ ; making these substitutes in the equation it becomes

$$\frac{d^2 a}{dt^2} + 2 \frac{a}{L} + \mathbf{f} + \mathbf{f}' \left( \frac{a}{L} + \mathbf{a} \mathbf{W} \right) = 0 \quad (26)$$

where  $p' = \bar{n}l p_0$ .  $a$  and its derivatives in this equation will have positive or negative signs, according as the number of multiplying levers is odd or even; this will be evident if we suppose the support to have an acceleration in the positive direction; the pendulum will be left behind; and the long end of the first lever will move in the positive direction, that of the second lever in the negative direction, etc. These are the equations of relative motion of the pendulum and of the marking point, and they are the only equations we have from which to deduce the movement of the support. It will be seen that, for the horizontal pendulum with the origin at the  $CG_0$  and to the degree of approximation used, the only displacements of the support which enter are the linear acceleration parallel to the axis of  $x$ , and the rotation around the axis of  $y$ ; but as both enter the equation we are not able to determine the value of either separately. (See, however, page 188.)

For the Milne instrument direct photographic registration is used; if  $l_x$  is the length of the beam from the axis of rotation to the slit for the recording light, then  $a = -l_x \dot{\theta}$ , since  $l_x \dot{\theta}$  and  $a$  are positive in opposite directions; and in equation (26)  $-\bar{n}l$  must be replaced by  $l_x$ . For the von Rebeur-Paschwitz form the optical method of registration is used; if  $D$  is the distance from the mirror on the pendulum to the recording paper, then  $a = -2D\delta$  and  $\bar{n}l$  must be replaced by  $-2D$ .

We see from the equation that 2 pendulums which have the same values of  $\bar{n}l$ ,  $i$ , and  $p_0$  have identical equations, and their movements for the same disturbance would be identical, although they might differ very much in mass and in form; and *vice versa*, in order that 2 pendulums should have identical motions for the same disturbance it is necessary that the constants above should have the same values for the 2 pendulums. This makes it perfectly clear why 2 dissimilar pendulums give such different records of the same disturbance; indeed 2 pendulums made as nearly alike as possible give dissimilar records if they have different values of  $i$ , *i.e.* different periods; or even if they have different values of  $p'$ . This was pointed out in 1899 by Dr. O. Hecker.<sup>1</sup> Two horizontal pendulums of the von Rebeur-Paschwitz type made as nearly alike as possible, mounted side by side, and having the same period of vibration, gave very different records of the same earthquake. The difference was found to be due to differences in the friction at the supporting points. Alterations were made until the friction was the same in the two instruments as shown by the similarity of the dying-out curves of free vibrations. After that the two instruments gave similar records of a disturbance.

<sup>1</sup> Zeit. für Instruamentenkunde, 1899, p. 266.



arises from the fact that we have taken our origin of coördinates at the  $CG_0$  of the pendulum.

If we go back to the equation (18) and eliminate the reaction of the indicator as before, but retain the term containing the angular acceleration about axis (3), we should find in our final equation the terms

$$(J_{(3)} + n^2 I_{(3)'}) \frac{d^2 \theta}{dt^2} + (I_3 + I_3') \frac{d^2 \omega_3}{dt^2}$$

which would be the only important terms in our equation, when a very small but very rapid angular acceleration occurred around axis (3). Integrating, we find

$$O - O_0 = \frac{a + V}{J_{(3)} + n^2 I_{(3)'}} \frac{a}{i} \cos \theta_0 \quad (30)$$

For the Bosch-Omori pendulum  $J_{(3)}$  is about 30 times  $J_3$ ;  $n^2 I_{(3)'}$  and  $I_3'$  are negligible; we therefore see that the angular displacement of the pendulum would only be about 5V of that of the support around the axis (3).

If, on the other hand, there is a permanent angular displacement about the axis of  $y$ , and no other disturbance, we must have for equilibrium  $\theta = a/nl \cos \theta_0 = c \cos \theta_0$ ; we have neglected the solid friction, which may act to increase or decrease the angle  $\theta$ , or the displacement  $a$ , according as the pendulum reaches its position of equilibrium from one side or the other. We shall see later how the value of  $p'$  affects the result, but neglecting it for the moment, we see that the angular displacement of the pendulum is  $1/i$  times that of the support. Hence  $1/i$  may be taken as the magnification of constant angular displacements around axis of  $y$ . For the Bosch-Omori instrument this is about 70, for the Milne, about 450, and for the von Rebeur-Paschwitz, about 700, when the period of vibration is about 17 seconds. As appears below,  $1/i$  is proportional to  $T_0^2$ .

If there is no disturbance and we neglect friction, equation (26) reduces to the form

$$\frac{d^2 \alpha}{dt^2} + \frac{g}{L} \alpha = 0 \quad (31)$$

whose solution represents a simple harmonic swinging of the pendulum with a period

$$T_0 = 2\pi \sqrt{\frac{L}{g}} \quad (32)$$

Therefore in equations (25) and (26),  $g/L$  can be replaced by  $(2\pi/T_0)^2$ ;  $T_0$  can readily be determined by observation.  $V = L/i$  is the length of a simple mathematical pendulum having the same period as the instrument under consideration.

Equation (26) may now be written

$$\frac{d^2 \alpha}{dt^2} + \frac{g}{L} \alpha = F \cos pt + T \sin pt \quad (26a)$$

It contains four constants, and when these are known the characteristics of the instrument are known. Two instruments, however they may differ in mass, size, shape, and even in type, as we shall see later, will give identical records of the same disturbance if these constants are respectively equal for the two instruments.

We have seen that  $JJ$  can very easily be determined through equation (32) by determining the period of vibration.  $V$  can be found by measuring the various quantities which define it in equation (29). Instead of measuring the value of  $L$  it can be found from  $L'$  through the relation  $L = iL'$ , after  $i$  has been found by one of the methods given below.

<sup>1</sup> If we use the displacement of the pointer to measure the rotation we have  $u_v = ia/VL$ .



There is a direct experimental method of determining  $V$  due to Professor Wiechert.<sup>1</sup> Displace the pendulum by applying a small force  $f$  at right angles to it and at a distance  $l'$  from the axis of rotation. Its moment will be  $fl'$ . The equal moment of restitution exerted by the pendulum will be  $Mgi\delta$ , where  $\delta$  is the angular displacement of the pendulum; this appears immediately from the theory of vibrating bodies if we replace  $L$  in equation (32) by its value  $lI/Ml$ .

Equating these two moments we find  $iO = fl'/Mg$ . If the marking point at the same time has been displaced a distance  $a_v$  then

$$V = \frac{a_v}{LO} = \frac{h/LB = a_v/U\delta}{iO} \quad (33)$$

$a_v$  is observed,  $L'$  determined through the period of vibration, and  $iO$  calculated by the moment of the applied force, as above.

In applying the force Professor Wiechert uses what is practically the beam of a balance with a vertical pointer; the latter presses against the pendulum with a force due to a weight placed at the end of the beam. If the length of the pointer is half the length of the beam, then a weight  $mg$  placed on the end of the beam will exert a pressure  $mg$  against the pendulum; and we find  $\delta = ml'/Ml$ .

Equation (32) also enables us to determine the value of  $i$ , which can not be measured directly with any degree of accuracy;  $L$  can be determined by measuring the quantities entering its definition (p. 155);  $g$  is supposed known and  $i$  can then be calculated. A special arrangement by which the von Rebeur-Paschwitz pendulum can be swung with its axis of rotation horizontal enables us to determine its  $i$  and  $L$  with ease. When  $i$  is large it must be replaced in the equation (32) by the accurate term  $\sin i$ ; when  $i$  is  $90^\circ$  this becomes unity, and we get for the period

$$T_* = 2\pi\sqrt{\frac{L}{g}}$$

from which  $L$  can be immediately calculated. When the pendulum is hung so that  $i$  is small, the period is given by equation (32), hence

$$i = TS/T_0^* \quad (34)$$

We have seen that if we tilt the support through an angle  $a$ , the pendulum is displaced through an angle  $\delta = \frac{a}{i}$ . It is easy to produce a known tilt on a Milne instrument by means of the leveling screws, and on the Bosch-Omori instrument by means of the horizontal adjusting screw at the top of the supporting column. The value of  $i$  can then be calculated by measuring  $\delta$  directly, or by calculating it through the displacement  $a_t$  of the pointer; for,  $VL = a_t/\delta = \overline{ml}_t$ ; and  $\overline{m}$  and  $l_t$  are very easily measured.

Returning again to equation (26), neglecting the solid friction and supposing no disturbance, the equation becomes

$$\ddot{a} + \frac{g}{L}a = 0 \quad (35)$$

of which the solution is

$$a = a_0 \sin \frac{2\pi}{T}(t - t_0) \quad (36)$$

provided  $2\pi/T$  is greater than  $\frac{g}{L}$ .  $a_0$  and  $t_0$  are constants to be determined by the initial conditions and  $T$  is given by

$$\left(\frac{2\pi}{T}\right)^2 = \frac{g}{L} \quad (37)$$

<sup>1</sup> Reiter's Geophysikalische Zeitschrift, vol. VI, p. 44S.

also 
$$\left| = \left( \frac{\Lambda}{T} \right) = (-) + \Lambda = (Y) \{1 + y\} \quad (38)$$

$$\therefore n = \frac{\Lambda}{\sqrt{1 + (.2y2\Lambda)^2}} \quad (38a)$$

If  $\epsilon$  is small, we can deduce

If, as in the majority of pendulums now in use, there is no especial device for damping,  $K$  is a very small quantity and we may, to a close degree of approximation, write  $T = T_0$  and  $2\pi r/T = 2\pi r/T_0$ .

The solution, equation (36), represents a simple harmonic motion with decreasing amplitude given by  $a_0 e^{-Kt}$ ; to determine the successive maximum swings in opposite sides of the central line, we put  $t = 0, T/2, 2T/2, \text{etc.}$ , in the expression. The ratio of these successive values of the amplitude is constant and equals  $V^{1/2}$ ; i.e., if  $a_0, a_1, a_2, \text{etc.}$ , are the successive maximum displacements we have

$$\frac{a_0}{a_n} = \frac{e^{-Kt_0}}{e^{-Kt_n}} = e^{-K(t_n - t_0)} = e^{-K \cdot n \cdot T/2} = e^{-n \cdot \frac{KT}{2}}$$

this quantity is called the *damping ratio*. To determine the value of  $tc$ , take the natural logarithms of both sides of equation (40); we get

$$\log_e \frac{a_0}{a_n} = 2.3026 \log_{10} 2^n = nA \quad (41)$$

where  $\log$  stands for the logarithm to the base 10.  $A$  is called the logarithmic decrement of the amplitude. From this equation we can calculate  $tc$ , but as it is difficult to get a good determination of the ratio of two successive amplitudes, we can determine  $K$  from the ratio of the zeroth to the  $n$ th. amplitude, as follows: Multiply together the successive ratios of equation (40) and we get

$$\frac{a_0}{a_n} = e^{-n \cdot \frac{KT}{2}} \quad (42)$$

take logarithms of both sides of the equation, and we get

$$\frac{1}{n} \log_{10} \frac{a_0}{a_n} = \frac{2.3026}{n} \log_{10} 2^n = \frac{A}{2} \quad (43)$$

This gives us more accurate values of  $\frac{A}{2}$  and  $A$ . The quantity needed to determine  $T_0$  in equation (39) is  $KT/2\pi$ , and this becomes

$$\frac{KT}{2\pi} = \frac{2.3026}{n} \log_{10} \frac{a_0}{a_n} = \frac{0.733}{n} \log_{10} \frac{a_0}{a_n} = \frac{A}{2\pi} \quad (44)$$

In determining  $K$  or  $KT/2\pi$ , one naturally observes  $a_0$  and  $a_n$ ; but the logarithmic decrement,  $A$ , is a recognized constant, and is the quantity usually recorded to indicate the damping of the instrument. It is to be noticed that the logarithmic decrement is not a constant, but is proportional to the damped period.

We also have from equation (38)

$$\left( \frac{\kappa T_0}{2\pi} \right)^2 = \left( \frac{\kappa T}{2\pi} \right)^2 / \left\{ 1 + \left( \frac{\kappa T}{2\pi} \right)^2 \right\} \quad (44a)$$

and through equations (40) and (41)

$$\left( \frac{\kappa T_0}{2\pi} \right)^2 = \frac{\log_e^2 \epsilon}{1 + \log_e^2 \epsilon} = \frac{\log_e^2 \epsilon}{1.862 + \log_e^2 \epsilon} \quad (44b)$$

The use of this formula is the quickest means of calculating the value of  $*T_0/2 TT_1$  which enters the expression for the magnifying power of the seismograph for harmonic vibrations.

The vibrations of the pendulum under damping lie between two exponential curves,  $e^{-kt}$  and  $-e^{-kt}$  as shown in figure 40.

There are few instruments free of all solid friction; this enters at the pivots and at the marking point. At the pivot it is merely a constant moment tending to stop the motion; but it may have a somewhat different value for motion in opposite direction. At the marking point the effect is different; in figure 41, let  $a$  be the pivot, and  $b$  the marking point of the indicator; let the recording paper be moving to the right with a velocity of  $v''$ ; let the marking point be moving to reduce  $\delta'$  with a velocity  $v'$ ;  $be$  and  $bd$ , as shown in the figure, will indicate the movements of the marking point relative to the paper, as the result of these movements respectively; the resultant relative motion will be  $be$ , and the frictional force which will be directed in the direction opposite to  $be$  may be represented by a constant  $\langle \mathcal{E} \rangle$ . Let  $\alpha$  be the angle which its direction makes with the direction of motion of the paper, and let  $\delta$  be the angular displacement of the lever from the same direction (which should be its direction of equilibrium).

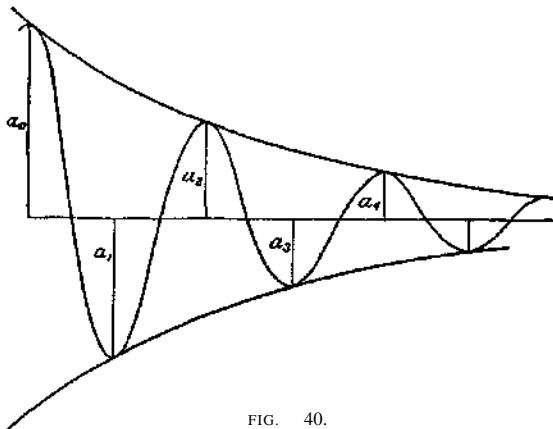

FIG. 40.

We may divide  $\langle \mathcal{E} \rangle$  into two components, one in the direction of the lever, which is resisted by a reaction at the pivot and does not tend to rotate the lever; a second at

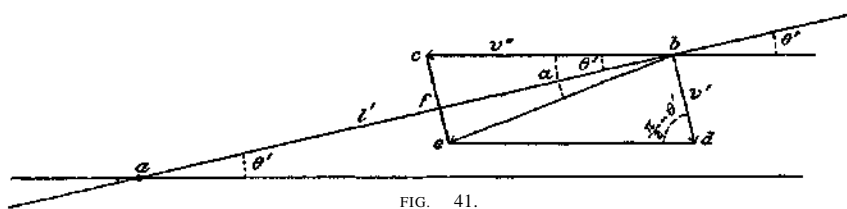

FIG. 41.

right angles to the lever, which exercises a moment to turn it; to determine this moment we must get the component of  $\langle \mathcal{E} \rangle$  in the direction of  $v'$  and multiply it by  $V$ . This effective moment is

$$-\langle bl' \sin(a - \delta') \rangle = -\frac{\langle \mathcal{E} \rangle l' \sin \alpha}{be} = -\frac{\langle \mathcal{E} \rangle l' \sin \alpha}{V u^{ff} + v'' - 2l' V \sin \delta'} \frac{v' - v'' \sin \delta'}{C^{40}}$$

This can be developed in powers of  $v'/v''$  (which we will write  $i_n$ ) or of  $v''/v'$  (or  $v^{\wedge}$ ) whichever is less than unity, and we get

$$\langle j \rangle V (l - v_x'' \sin \delta') (1 - r' V S + \dots) \sin \delta' + \dots - j \rangle \langle t \rangle V (v_n' - \sin ff) (\dots - v_u''/2 - v_x' \sin ff + \dots) \quad (46)$$

or

If the lever is moving very rapidly in comparison with the paper,  $v''$  becomes a small quantity, it may be neglected, and the first expression becomes  $\$I$ , that is, there is a constant moment tending to stop the motion of the pendulum. If the paper is moving very rapidly in comparison with the lever,  $v_n'$  is a small quantity, and the second expression reduces to  $\#^f(i_n' - \sin \theta' - v_n' \sin^2 \delta' - \dots)$ ; which, when  $\theta'$  is small,

become  $\delta'(\theta' - \theta)$ , this represents a moment proportional to the velocity of the lever, and a second proportional to the displacement.

In the intermediate case where neither  $v'$  nor  $v''$  is preponderatingly large, the frictional moment is a complex function of their ratio and of the angular displacement. In any large swing the recording point may pass thru its position of equilibrium with a velocity much larger than that of the paper, but as it reaches the limit of its swing its velocity gradually reduces to zero; hence the nature of the moment brought into play varies materially during the swing. As the lever passes its zero position the friction exercises a constant moment; and as it approaches the maximum displacement the friction exercises a damping moment, and a force of restitution.

It sometimes happens, on account of a slight tilting of the pier, that the pendulum's equilibrium position is not exactly in a line with the pivot of the indicator lever, so that

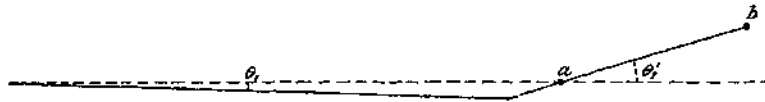

FIG. 42.

the lever stands at an angle with the pendulum. The frictional moment has the same expression as we have already found except that we must replace  $\delta'$  by  $\delta' + \theta'$ , where  $\theta'$  is the angular displacement of the indicator when the pendulum is at rest, and  $\delta'$  the displacement from this position during a disturbance. The limiting cases (as on p. 161) become  $\delta' > \theta'$  and  $\delta' < \theta'$  if  $\theta'$  and  $\theta$  are not large; that is, in the second case, we must add to the moments already considered another moment which tends to bring the pendulum back to the proper position of equilibrium.

Let us see what is the nature of the frictional moment in a special case; let us suppose we have a simple harmonic swing of the marking point of period,  $P = 15$  sees., and amplitude 4 cm.; let the velocity of the paper be 1.5 cm. per minute, or  $v'' = 0.025$  cm. per second. We have supposed the swing simple harmonic, which it would not be under the action of the friction, but it would be approximately so, and we can get a fair idea of the variation of the frictional moment under this supposition. If  $y$  is the displacement, we shall have

$$y = a \sin \frac{2\pi}{P} t; \quad v' = \frac{dy}{dt} = \frac{2\pi a}{P} \cos \frac{2\pi}{P} t$$

then  $2\pi a/P = 25/15 = 1.67$ , and putting the successive values of the sine in the general equation for the frictional moment (45), we find that the force does not vary much for something over an eighth of the period on each side as the pointer crosses the zero position, and it changes very quickly near the ends of the swings; for movements therefore in which the maximum value of  $v'/v''$  is of the order of  $1.67/0.025 = 67$ , the frictional moment does not vary much in value during a large part of the swing. It would produce a much too complicated expression to introduce the actual value of the frictional moment into the equation of the pendulum; the best we can do is to look upon it as made up of a damping moment, which would enter the general damping term, a moment proportional to the displacement, which would combine with a similar term in the equation, and of a constant moment opposed to the motion, which would be represented, together with pivotal friction, by the constant term of the equation. The importance of reducing all this friction to a minimum is evident, for we can not take accurate account of it. Hence the adoption of very heavy pendulums, which reduce the effect of the frictional forces on their motion. That the friction at the recording point is, in general, very important, is shown by the rapid dying out of the vibrations of a Bosch-Omori

pendulum when the pointer is marking, in comparison to the very slow dying down when the marking point does not touch the smoked paper. The effect of the multiplying levers in increasing the influence of the friction can easily be found. Using the same notation as on pages 151, 155, we have

$$f_1 l_2 = f_2 l_1'; f_2 l_3 = f_3 l_2'; \text{ etc.}$$

where for this particular case, the  $f$ 's represent the reaction between the levers brought about by the friction  $\langle f \rangle$ , of the marking point only, and the inertia of the levers is not considered.

This gives

$$f_1 l_1 = f_1 M_{l_2} = \dots = \phi \frac{l_1}{l_2} \wedge \dots \frac{l_1}{l_n} = \phi \bar{m} l_1 = \phi \bar{m} l_1 \quad (47)$$

that is, the frictional moment is proportional to the multiplying power of the levers.

Assuming that the friction adds a damping moment, a moment proportional to the displacement, and a constant moment, opposing the motion of the pendulum, we have still to determine in our general equation (26) the values of the constants  $K$  and  $p'$ . If in this equation we replace  $a$  by  $a' T L p'/gi$ , it becomes

$$\frac{d^2 a'}{dt^2} + \frac{2\pi}{T_0} \frac{da'}{dt} - \frac{\bar{m} l}{L} \frac{d^2 \xi}{dt^2} + \frac{g}{L} \left( \frac{\bar{m} l}{L} a' + a' \right) = 0 \quad (48)$$

the form is unchanged except that the constant term drops out. Therefore the vibration of a pendulum, affected by constant friction, has the same period and is otherwise the same as that of a pendulum without the friction, except that the vibration no longer takes place about the medial line, but about a line displaced from it by an amount  $L p'/gi$ , and this displacement is first on one side of the medial line and then on the other. We may therefore look upon the force of restitution, not as proportional to  $a$ , the displacement, but to  $a$  less  $L p'/gi$ ; and the pendulum can remain at rest anywhere between the two displaced medial lines. Let us call the distance between the true medial line and its displaced position, the "frictional displacement of the medial line," and denote its value,  $L p'/gi$  or  $p' T^2 r$ , by  $r$ . It must be determined by experiment. We have just seen that the frictional moment exerted on the pendulum is proportional to the multiplying power of the levers, therefore the frictional displacement of the point  $l_x$  is proportional to the same quantity; and the frictional displacement of the marking point is  $\bar{m}^2$  times as great, or proportional to the square of the multiplying power. Suppose the frictional displacement of the marking point at  $l_x$  were 0.01 mm., that at the end of one lever multiplying 10 times would be 1 mm.; and at the end of a second similar lever, 100 mm. We can determine the relation between  $p'$ ,  $r$  and  $\langle f \rangle$ ; the frictional force  $\$$  exerted at the marking point equals a force  $\bar{m} \langle f \rangle$  exerted at the point of contact,  $l_v$  of the pendulum and the first lever, and this exerts a moment  $\langle f \rangle \bar{m} l_v$ , and therefore produces an acceleration of the pendulum equal to  $\langle f \rangle \bar{m} Z_j / [I]$ ; this acceleration is represented by  $PQ$  in equation (25). Hence

$$p' = \left( \frac{2\pi}{T_0} \right)^2 \bar{P} \bar{O} - \frac{\phi \bar{m} l \bar{m} l}{U T} \sim \bar{m} \quad (49)$$

In figure 43, let  $a_0, a_1, a_2$ , etc., be the successive excursions measured from the medial line; let  $r$  be the displacement of the medial line; then if there is no damping and the pendulum starts from a displacement  $a_0$ , that is  $a_0 - r$  from the displaced line, it will swing an equal distance to the other side of this line, or  $a_0 - r = a_1 + r$ ;  $\therefore a_1 = a_0 - 2r$ ; as it starts back from  $a_1$  the medial line is suddenly displaced to (2), and  $a_1 - r = a_2 + r$ ;

$\therefore a_2 = a_1 - 2r$ ; and we see that each successive excursion of the pendulum is diminished by  $2r$ . When at last the friction stops the motion between the lines (1) and (2), the point

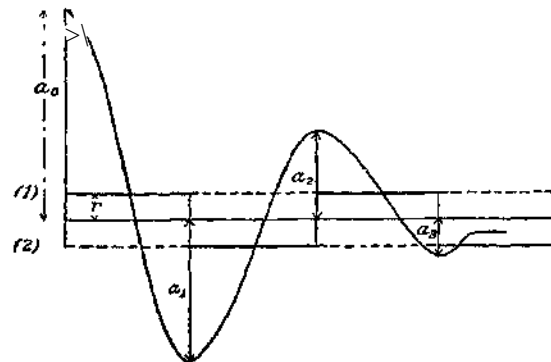

FIG. 43-

will cease to vibrate, the friction being just enough to hold it in the position where it stops. But when the vibration becomes very small, the friction no longer exerts a constant force, but a damping force and a force of restitution, and therefore the marking point would continue to approach the true medial line, being kept from it only by the constant friction of the pivots.

When there is damping, the successive excursions about the displaced lines are not equal, but they gradually

diminish in the ratio  $e^{-KT/p}$ , which we have called  $e$ ; we have therefore

$$\frac{a_0 - r}{a_1 + r} = \frac{a_1 - r}{a_2 + r} = \dots = e \quad (49)$$

and it is from this series of equations that we must determine  $K$  and  $p$ . As the position of the medial line may be unknown, we can not measure the  $a$ 's, so we must proceed as follows: adding numerators and denominators of the equal fractions we get

$$\frac{a_0 + a_1 - 2r}{a_1 + a_2 + 2r} = e \quad \text{or} \quad \frac{A_1 - 2r}{A_2 + 2r} = \frac{A_2 - 2r}{A_3 + 2r} = \dots = e \quad (50)$$

where  $A_x = a_x + a_v$ ,  $A_0 = a_0 + a_1$ , etc., the  $A$ 's are the ranges of the vibrations, that is, the distances from a maximum excursion on one side to the next on the other. Subtracting the numerators and denominators, the second from the first, the third from the second, etc., we find

$$\frac{A_1 - A_2}{A_2 - A_3} = \frac{A_2 - A_3}{A_3 - A_4} = \dots = e \quad (51)$$

Solving the first equation (50) for  $2r$  and introducing the value of  $e$  from the first equation (51), we get

$$2r = \frac{A_1 - A_2}{A_2 - A_3} \quad (52)$$

Equations (51) and (52) enable us to determine the values of  $e$  and  $r$  from the measure of three successive ranges; these equations are suitable when the ranges diminish rapidly in value; but when they diminish very slowly, these equations will not yield accurate values, and we must deduce others containing ranges which are sufficiently far apart to have materially different values. We proceed as follows: add the numerators and the denominators of equations (51) and we get

$$\frac{A_1 - A_m}{A_2 - A_{m+1}} = \frac{A_2 - A_{m+1}}{A_3 - A_{m+2}} = \dots = e \quad (53)$$

multiplying  $n$  of these fractions together, we get

$$\frac{A_1 - A_m}{A_{n+1} - A_{n+m}} = e^n$$

$m$  and  $n$  may be any numbers we please; let us take  $m = n + 1$ , and the formula becomes

$$\frac{A_1 - A_{n+1}}{A_{n+1} - A_{2n+1}} = e^{n+1} \quad (54)$$

From this we deduce as before

$$\frac{MM}{2\pi n} \left( \frac{A-i}{A+i} \right)^n = \frac{A-i}{A+i} \left( \frac{A-i}{A+i} \right)^{n-1} \dots \left( \frac{A-i}{A+i} \right) \quad (55)$$

Solving equation (50) for  $2r$ , we get

$$2r = \frac{A - \epsilon A}{1 + \epsilon} - \frac{A^2 - \epsilon^2 A}{1 + \epsilon} \dots \epsilon^n$$

$$= \frac{A - \epsilon A}{1 + \epsilon} = \frac{eA - \epsilon^2 A}{e(1 + \epsilon)} \dots \text{etc}$$

adding numerators and denominators

$$2r = \frac{A - \epsilon^{n+1} A}{1 - \epsilon^{n+1}} = \frac{A - \epsilon^{n+1} A}{1 - \epsilon^{n+1}}$$

replacing value of  $\epsilon^n$  from equation (54) we get

$$2r = \frac{A - \epsilon^{n+1} A}{1 - \epsilon^{n+1}} = \frac{A - \epsilon^{n+1} A}{1 - \epsilon^{n+1}} \quad (57)$$

Equations (55), (56) and (57) are perfectly general; and  $n$  may be given any integral value greater than 0. The factor  $(e - 1)$  in equation (57) reduces the accuracy in the determination of  $r$  when  $e$  is nearly equal to 1; but  $e$  can be determined with considerable accuracy from equation (54) if we have a good record of free vibrations without outside disturbance,  $r$  being thus determined, we can find  $p'$  and  $\xi$  from equation (48a). Thus the damping and frictional constants can be determined from the measure of 3 ranges.

Returning now to equation (35), let us consider the case where the friction is so great that the movement is no longer periodic so that we can not determine  $K$  and  $p'$  by the above methods. We shall then have  $K > 2\pi/T_0$ , and the solution of the equation (35) under this condition is

$$a = A_1 e^{-m_1 t} + A_2 e^{-m_2 t} \quad (58)$$

where

$$m_1 = K \pm \sqrt{K^2 - n^2}, \quad m_2 = K - \sqrt{K^2 - n^2} \quad (59)$$

and  $n$  is written for  $2\pi/T_0$ .  $A_1$  and  $A_2$  are arbitrary constants whose values are to be determined to correspond to the special conditions imposed. Neglecting solid friction for the present, we can determine the value of  $K$  by displacing the pendulum an amount  $a_0$  and then setting it free; that is, at time  $t_0$  we have  $a = a_0$  and  $da/dt = 0$ . If we determine  $A_1$  and  $A_2$  to satisfy these conditions, equation (58) becomes

$$a = \frac{5^0}{m_1 - m_2} (m_1 e^{-m_2 t} - m_2 e^{-m_1 t}) \quad 0 \quad )$$

This represents the difference of two exponential curves, and since  $m_1$  is greater than  $m_2$ , the second term in the parenthesis is always smaller than the first and  $a$  is always positive; and therefore the pendulum remains on the positive side of the position of equilibrium, gradually approaching it, but only reaching it when  $t$  is  $\infty$ .

To determine  $K$  we must first determine  $n$  or  $2\pi/T_0$ . To do this, reduce the value of  $K$  sufficiently to allow a satisfactory periodic motion, and determine the period. Increase the value of  $K$  until the motion is aperiodic. Now displace the pendulum an amount  $a_0$  and release it exactly at the beat of a seconds pendulum; determine the deflection from its position of equilibrium at, say, every 5 or 10 beats of the pendulum. On substituting the values of  $a_0$ ,  $n$ , and  $t$  in equation (60) we can determine  $K$  by trial, each observation giving a value of  $K$ ; the average can then be taken. It would be very difficult to deter-

mine  $K$  using the ordinary method of recording; a much better way would be to attach a small mirror to the pendulum and read the deflections with a telescope and scale in the ordinary method used for delicate galvanometers. If electro-magnetic damping is used, it is easy to vary the damping, but with mechanical methods it is much more difficult.

In the particular case when  $K = 2\pi/T_0$  the solution of equation (35) becomes

$$a = e^{-\kappa t} (A_1 + A_2 e^{\kappa t}) \quad (61)$$

If the pendulum were displaced a distance  $a_0$  and released at time  $t = 0$ , the arbitrary constants  $A_1$  and  $A_2$  take such values that the equation becomes

$$a = a_0 e^{-\kappa t} (1 + \kappa t) \quad (62)$$

and the pendulum approaches its position of equilibrium rapidly at first but only reaches it after an infinite time. If we have control over the damping factor, we can attain this condition by starting with a damped periodic vibration and then increasing the value of  $K$  until the pendulum no longer crosses its equilibrium position, when displaced and released; the value of  $K$  would then be  $2\pi/T_0$ .

A second method to determine  $K$  is to start the pendulum into sudden motion by a smart blow delivered at the center of oscillation and then determine the time for it to attain its greatest displacement. Equation (58) becomes under these conditions

$$a = \frac{v_0}{m_1 - m_2} (e^{-m_1 t} - e^{-m_2 t}) \quad (63)$$

where  $v_0$  is the initial velocity. If we put  $da/dt$  equal to zero, we find that the time of greatest displacement,  $t_v$  is given by

$$(m_1 - m_2) t_v = \log \frac{2m_2}{m_1 - m_2} = 0.4343 \log_{10} \frac{m_1}{m_2} \quad (64)$$

Under similar conditions, equation (61) becomes

$$a = v_0 t e^{-\kappa t} \quad (65)$$

and the time of greatest displacement is given by

$$h = \frac{l}{\kappa} \quad (66)$$

The effect of solid friction is merely to shift the position of equilibrium; this, however, is only strictly true provided  $p'$  is truly constant; but we have seen that this is not the case when the movement of the pendulum is slow in comparison with that of the drum, as it would be during a large part of the motion in the case under consideration. Prince Galitzin is the only person so far who has used such excessive damping, and he has used optical registration so that the friction of the marking point is absent. If mechanical registration were to be used with a so strongly damped instrument, a careful experimental study should be made of its effect, as we can not say that we know how to allow for it at present.

#### INTERPRETATION OF THE RECORD.

We have seen how to find the values of the constants which enter the equation of the horizontal pendulum, so that we can apply the equation to a given record and find the corresponding movement of the support. To do this we must integrate the equation;



that is, we must substitute for  $a$ ,  $da/dt$ , and  $d^2a/dt^2$ , their values as given by the record, and we can then calculate  $d^2a/dt^2$ . If, as is generally the case, the record is not a simple regular curve, we must determine the values of  $a$  and those of its derivatives for points of the curve at very small intervals and then integrate the resulting values of  $d^2a/dt^2$ , graphically or otherwise. This process is very long. If, on the other hand, the record is a simple harmonic curve, and it frequently approximates this for short times, we can integrate the equation directly. Equation (26) becomes, after substituting the values of the coefficients,

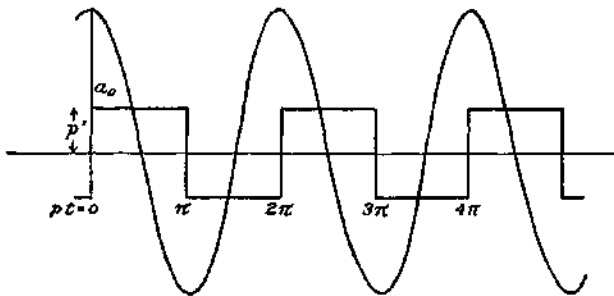

FIG. 44.

$$\frac{d^2a}{dt^2} + 2\kappa \frac{da}{dt} + n^2a - V \frac{d^2\xi}{dt^2} + Vg\omega_v \mp p' = 0 \quad (67)$$

where we have put  $n^2$  for  $g/L$ , or  $(2^r r/T_0)^2$ , by equation (32).

Let us suppose first that there is no rotation, and the term  $Vg\omega_v$  disappears. Choosing the origin of time when the pendulum has its greatest elongation in the positive direction, we can write

$$a = a_0 \cos(2\pi r/F)t = a_0 \cos pt \quad (68)$$

$$da/dt = -pa_0 \sin pt; \quad da^2/dt^2 = -p^2 a_0 \cos pt \quad (69)$$

$p'$  is a discontinuous function, having a constant numerical value, but suddenly changing sign with the velocity which it always opposes. We can represent it by the series

$$p' = \frac{4}{\pi} \sum_{n=1}^{\infty} \frac{1}{n} \sin npt + \frac{1}{3} \sin 3pt + \frac{1}{5} \sin 5pt + \dots \quad (70)$$

where  $n^2 r$ , or  $(2^r r/T_0)V$ , as in equation (48a), is the positive numerical value of  $p'$ ; this series represents the broken line in figure 44 for all values of  $t$ . Substituting the above values in the equation of the pendulum, it reduces to

$$V \frac{d^2\xi}{dt^2} = A \cos(pt - \chi) - \frac{4n^2 r}{\pi} (\sin pt + \frac{1}{3} \sin 3pt + \dots) \quad (71)$$

where

$$A \cos \chi = \frac{4n^2 r}{\pi} \cos \chi; \quad A \sin \chi = -\frac{4n^2 r}{\pi} \sin \chi; \quad A^2 = \frac{4n^2 r}{\pi} \{ (n^2 - p^2)^2 + (2\kappa p)^2 \} \quad (72)$$

Multiplying by  $dt$  and integrating from  $t = 0$  to  $t = t$ , we get

$$V \frac{d\xi}{dt} - V \left( \frac{d\xi}{dt} \right)_0 = \frac{A}{p} \sin(pt - \chi) + \frac{A}{p} \sin \chi + \frac{4n^2 r}{\pi p} \left( \cos pt + \frac{1}{3} \cos 3pt + \dots \right) - \frac{4n^2 r}{\pi p} \left( 1 + \frac{1}{3} + \frac{1}{5} + \dots \right) \quad (73)$$

Integrating again, after replacing the last series by its value,  $T^2/S$ , we get

$$V\xi - V\xi_0 - V \left( \frac{d\xi}{dt} \right)_0 t = -\frac{A}{p^2} \cos(pt - \chi) + \frac{A}{p^2} \cos \chi + \frac{A}{p} \sin \chi \cdot t + \frac{4n^2 r}{\pi p^2} \left( \sin pt + \frac{1}{3} \sin 3pt + \dots \right) - \frac{\pi n^2 r}{2p} t \quad (74)$$

Since this holds for all values of  $t$ , we must have

$$\left. \begin{aligned} V \left( \frac{d^2 h}{dt^2} \right) &= -\frac{A}{p} \sin x + \frac{r n^2 r}{2p} \\ V \xi_0 &= -\frac{A}{p^2} \cos \chi \\ V \xi &= -\frac{A}{p^2} \cos (pt - \chi) + \frac{4 n^2 r}{\pi p^2} \left( \sin pt + \frac{1}{3^3} \sin 3pt \dots \right) \end{aligned} \right\} \quad (75)$$

The series converges so rapidly that we may neglect all but the first term; indeed, if we attempt to draw the curve represented by the series making the amplitude of the first term 25 mm., that of the second term would be a little less than 1 mm. and would have a small effect (see figure 45); that of the third term would only be  $\frac{1}{27}$  mm., and its effect would hardly be perceptible on this scale. When we consider that the friction is by no means constant during a half swing of the pendulum, and that the curve recorded by our instrument is by no means an accurately harmonic curve, we feel entirely justified in accepting the value of  $\xi$  obtained by neglecting all terms of the series except the first, as representing its true value well within the limits of our observations. We then have

$$V \xi = -\frac{A}{p^2} \cos (pt - \chi) + \frac{4 n^2 r}{\pi p^2} \sin pt = B \cos (p^* t - \phi) \quad (76)$$

where

$$B \cos \phi = \frac{A}{p^2} \cos \chi \quad B \sin \phi = \frac{4 n^2 r}{\pi p^2} \sin \chi \quad B^2 = \frac{A^2}{p^4} - \frac{8 n^2 r}{\pi p^4} A \sin \chi + \frac{16 n^4 r^2}{\pi^2 p^4} \quad (77)$$

If, however, we wish to take into account the second term of the series in equation (75), the second term of equation (76) must be increased by  $(4n^2/7rp^2)(\sin 3^2/27)$ , and we observe that it will have no effect on the maximum amplitude if  $\chi$  is 0, or  $\pm 60^\circ$ , or

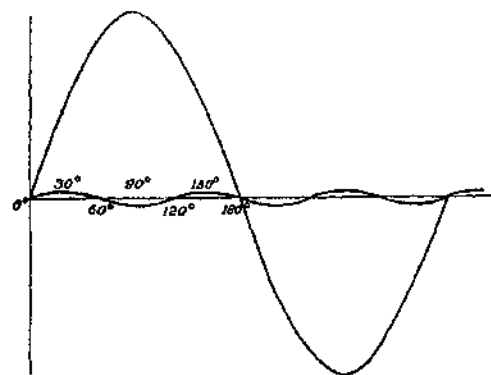

FIG. 45.

$\pm 120^\circ$ , or  $\pm 180^\circ$ ; that it will increase  $B$  by  $4rn^2/277rp^2$  if  $\chi = +30^\circ$ , or  $+150^\circ$ , or  $-90^\circ$ ; that it will decrease it by the same amount if  $\chi = -30^\circ$ , or  $-150^\circ$ , or  $+90^\circ$ . If we suppose the period of the disturbance to be twice that of the pendulum,  $n^2/p^2 = 4$ ; and if  $r = 0.2$  cm., then the change in  $B$  may, at most, amount to  $0.8 \times 4/27 TT$ , or about 2V cm.; and if  $V$  is 10, the alteration in the calculated value of the amplitude of the earth's disturbance may amount to  $\frac{1}{27}$  cm. or  $\frac{1}{27}$  mm. As the actual amplitude is apt to be one or more millimeters to produce a movement large enough to justify us in

regarding  $p^f$  as a constant and thus make these calculations apply, the effect of the second term of the series may be neglected within the limits of errors of observations and theory. These data are fair values for the Bosch-Omori seismograph; for other instruments they would have to be modified.<sup>1</sup>

<sup>1</sup> If we wish to avoid all approximations in our solution, we can do so by replacing the two series of equation (73) by their values

$$\frac{\pi n^2 r}{2p} \frac{d^2 h}{dt^2} = \frac{4 n^2 r}{\pi p} \left[ \cos pt + \frac{1}{3^2} \cos 3pt + \dots \right] \quad \frac{v r f r}{2j \theta} = \frac{4 n^2 r}{v p} \left( 1 + \frac{1}{3^2} + \dots \right)$$

on integrating we find

$$V \xi = -\frac{A}{p^2} \cos (pt - \chi) + \frac{\pi n^2 r t}{2p} - \frac{n^2 r t^2}{2}$$

This equals the values given by equation (75) between  $t=0$  and  $t=P/2$ ; but it does not hold outside these values; and the variation from the harmonic form is not so readily seen.

We find, therefore, that a simple harmonic record corresponds pretty closely to a simple harmonic disturbance magnified in the proportion of

$$\frac{a_0}{B/V} = \frac{a_0 v}{\sqrt{A^2/p^4 + (8n^2r/\pi p^4) A \sin \chi + 16n^4r^2/\pi^2 p^4}} \quad (78)$$

since  $B/V$  is the amplitude of the movement of the support or the earth. In the simple case where  $r=Q$ , or where it is small enough to be neglected, the denominator reduces to  $A/p^2$ , and we have, substituting the value of  $A/p^2$  from equation (72)

$$W = \frac{V}{\sqrt{4P^2(K/2TT)^2 + \{(P/T_{of} - I)^2\}}} = \frac{V}{\sqrt{4(KT_{of}/2ir)\{P/T_{of} + \{(P/T_{of} - I)^2\}}}} \quad (79)$$

or by equation (44b)

$$W = \frac{V}{\sqrt{4 \frac{\log^2 \epsilon}{1.862 + \log^2 \epsilon} \left(\frac{P}{T_0}\right)^2 + \left\{\left(\frac{P}{T_0}\right)^2 + 1\right\}}} \quad (79a)$$

This is the formula given by Doctor Zoeppritz and is perhaps in as simple form for calculation as it could be put. It is a function of the ratio  $P/T_0$ ; the constants of the instrument are taken account of in the quantities,  $T_0$ ,  $e$ , and  $V$ ; the latter we have seen equals  $\bar{n}/L$ . In the particular case where  $P = T_0$ , the magnifying power becomes

$$W = \frac{FTT}{KT_0} = \frac{TV^{\wedge-f-\log/e}, Fyi.862 + \log^2 \epsilon}{2 \log_e e} \quad (80)$$

which grows larger as  $K$  or  $e$  grows smaller; but neither  $K$  nor  $e$  can ever absolutely vanish, and therefore this magnifying power can never become infinite, though it may become very large.

If the solid friction may not be neglected, we must use the full denominator of equation (78) and the magnifying power becomes

$$B/V = \frac{V}{\sqrt{4(KT_{of}/2ir)\{P/T_{of} + \{(P/T_{of} - I)^2\}} + \{(P/T_{of} - I)^2\}}}$$

in which  $(KT_{of}/2ir)$  may be replaced by its value given in equation (44b).

The solid friction adds two terms to the denominator and reduces the magnifying power; these terms depend not only on the value of  $KT_{of}$ ,  $P/T_{of}$  and  $r$ , but also on the recorded amplitude, becoming less important as the amplitude increases. These formulæ, equations (79 a) and (81), are rather complicated, and could not be easily and quickly computed.<sup>1</sup> In reporting amplitudes, it would be much better for each observer to determine the magnifying power of his instrument and to report the actual movement of the ground, instead of the movement of his instrument as is usually done.

We have found (p. 168) that a simple harmonic vibration of the pointer,  $a = a_0 \cos pt$ , is the result of an approximately simple harmonic disturbance of the support,  $I = (B/V) \cos(pt - f)$ . This result is true whatever be the value of  $*$ , therefore it holds whether the free movement of the pendulum is simple harmonic as on page 158, or an exponential curve as on pages 159 and 165. We can reverse the result and say a simple harmonic movement of the support will produce an approximately simple harmonic movement of the pointer.

<sup>1</sup> A table, giving the values of the denominators of (79 b) for various values of  $\epsilon$ , and of  $P/T_0$  has been published by Dr. Karl Zoeppritz in "Seismi.sche Registrierungen in Göttingen im Jahre 1906." Nach. d. K. Geselte. d. Wiaa. Math.-Phys. Kl. Göttingen, 1908.

If the movements of the pendulum are simple harmonic, and due to tilts alone without linear displacements, we merely interchange  $-Vg < o_v$  for  $Vd^2Z/dt^2$  in equation (71); we get

$$\omega_y = -\frac{A}{r} \cos(pt - \chi) \mp p' \quad (82)$$

As  $o_v$  does not enter the equation as a derivative, no integration is necessary,  $p'$  changes its value suddenly from  $-p'$  to  $p'$ , or *vice versa*, when  $pt$  is zero or any multiple of  $\pi$ ; therefore  $\omega_y$  consists of parts of a simple harmonic curve separated by sudden discontinuities at these times. But as we can not admit discontinuities in the value of  $co_v$ , we must conclude that when  $p'$  has an appreciable value, a simple harmonic movement of the pointer can not be produced by tilts of the ground.

We are therefore led to reverse the process and determine what movement of the pointer would be produced by a simple harmonic tilt of the ground. We must replace  $Vgco_y$  in equation (67) by  $Ea \cos(pt - f_0)$  and integrate the equation after omitting  $Vd^2Z/dt^2$ . (The same solution would apply to the case of simple harmonic linear displacements if we omitted  $Vgco_y$ , and replaced  $Vd^2Z/dt^2$  by  $E \cos(pt - \theta_0)$ ; that is, if we made  $f = -(E/Vp^2) \cos(pt - \theta_0)$ .) The solution of the equation would then be very simple if we could neglect  $p'$ , but when we consider this term it becomes rather complicated; but it can be found. From the nature of the disturbing force, and on account of the damping and friction, it is evident that after a short time the movement of the pendulum must become periodic and have the same period as the force. We can therefore write the solution in the general form

$$a = a_1 \cos pt - f a_2 \cos(2pt - tf/2) - f \dots \text{etc.} = \sum a_m \cos(mpt - \phi/m) \quad (83)$$

where  $m$  represents all positive integers. It is also evident that the arms of the broken curve in figure 46 (which represents the movements of the pointer; the continuous curve represents the disturbance) from  $a_0$  to  $a_x$

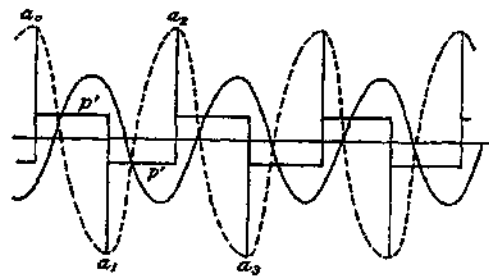

Fig. 46.

and from  $a_x$  to  $a_y$  must be perfectly similar, as the forces when the pendulum is moving in one direction are exactly the negative of those when it is moving in the opposite direction. Therefore the time the pendulum takes to swing from  $a_0$  to  $a_1$  will be exactly half its period, and if we take the time as zero when the pendulum is at  $a_0$ , its maximum displacement, we can develop  $p'$  as a series of sines of the form of equation (70). Substituting these values in equation (67), after omitting  $Vd^2Z/dt^2$ , and requiring the equation to be identically satisfied, we have, with the equation  $da/dt=0$  when  $\phi=0$ , a sufficient number of conditions to determine the values of the amplitudes  $a_1, a_2, \dots$ , and the phases  $\phi_1, \phi_2, \dots$  of equation (83), and thus completely to determine this solution. The work is rather long and it will be sufficient to give the result. We find for the solution

$$\left. \begin{aligned} a_1 &= \sqrt{Q^2 + S^2/p} \\ a_m &= \frac{Q \cos pt + \frac{1}{p} \sin pt - \frac{V}{irm} \frac{4n^*r^2 \cos mpt + \frac{(m^2p^2 - n^*)^2}{(my-n^2)^2 + (2Kmp)^2} \sin n mpt}{(m^2p^2 - n^*)^2 + (2Kmp)^2}} \end{aligned} \right\} \quad (84)$$

where  $m$  has all odd positive integral values greater than 1.  $a_m = 0$ , when  $m$  is even.

$$S = \sum \frac{4n^*r}{\pi m} \frac{raV - w^2}{(m^2p^2 - n^*)^2 + (2Kmp)^2}$$

with the same values of  $m$ .

$Q$  is found from the quadratic equation

$$Q^2 \frac{N^2 + (2\kappa p)^2}{p^2} + 2Q \frac{8\kappa n^2 r}{\pi} + \delta^2 \frac{N^2 + (2\kappa p)^2}{p^2} + \left(\frac{4n^2 r}{\pi}\right)^2 - \frac{8NSn^2 r}{\pi p} - E^2 = 0$$

where  $N'$  is written for  $n^2 - p^2$ . The other letters have the same meanings as heretofore.

$$\sin iZ_m = \frac{m^2 p^2 - n^2}{\sqrt{(m^2 p^2 - n^2)^2 + (2\kappa m p)^2}} \cos iZ_m = \frac{2\kappa m p}{\sqrt{(m^2 p^2 - n^2)^2 + (2\kappa m p)^2}}$$

The presence of both sine and cosine terms in (84) shows that the movement of the pointer is not symmetrical about a vertical line. The solution is too complicated to be of any general use and is another example of the disadvantage of solid friction in our seismographs.

If the disturbance is small, it may not be strong enough to overcome the solid friction; referring again to equation (67), we see that no record will be made in the case of linear displacements unless

$$d^2/dt^2 > p'/V, \text{ or } > n^2 r/V, \text{ or } > 4\kappa^2 r/VT_1^2, \text{ or } > f > ml_1/Ml;$$

if

$$f = X \cos pt$$

we must have the maximum acceleration,  $p^2 X > n^2 r/V$ ; that is,  $X > (P/T_n)^2 r/V$ , or  $> (P/2-7r)^2 f > ml_1/Ml$ . If the disturbance is a small tilt,  $\alpha_y$  must be greater than  $p'/Vg$ ; if  $a_y = X_i \cos qt_i$  in order that a record be made we must have  $Q_i > \pm ir^* r/VgT_i^2$ , or  $> f > ml_j Ml g$ . In studying the action of solid friction it has been supposed to be due both to friction at the pivots and to friction of the marking point; where the latter exists at all it is apt to be much greater than the former. If we are dealing with small disturbances of periods not very short, the friction at the marking point is no longer a constant, but has the characteristic of viscous damping. So that in determining the smallest disturbance that will produce a record, under these conditions, we must suppose  $p'$  to refer to the pivots only and not to the marking point.

Professor Marvin has shown how  $f$  can be practically reduced, and consequently  $p'$  and  $r$ , can be practically reduced. He attaches a small electric vibrator to the frame carrying the lever, and the successive slight jars produced by it diminish the effective solid friction to a large extent.<sup>1</sup>

The solutions we have found, showing the relations between the disturbance and the record when solid friction is present, refer to the final steady condition and do not apply to the beginning of the disturbance. The character of the record at the beginning of a simple harmonic disturbance can not be shown in a continuous form, as we can not represent  $p'$  as a series unless it is periodic and we know the times when it changes sign. In the beginning of a disturbance these conditions will, in general, not hold. The same remark applies to the case where the disturbance consists of two or more simple harmonic motions of different periods. But if  $p'$  can be neglected, these difficulties disappear and the solution of equation (67) becomes simple. If we suppose the disturbance to be made up of a number of simple harmonic linear displacements and tilts, we must write in the equation:

$$\text{whence } \left. \begin{aligned} F \ddot{x} &= C_1 \cos(p_1 t - x_0) + C_2 \cos(p_2 t - x_2) + \dots \\ \frac{d^2}{dt^2} F \sim f &= \sum_i \frac{1}{P_i} \cos(p_i t - x_i) + \dots \end{aligned} \right\} \quad (85)$$

$$\text{and we must write } Vg < \delta = D_x \cos\{q_1 t - \phi_1\} + D_2 \cos\{\phi_2 - \phi_1\} + \dots \quad (86)$$

<sup>1</sup>Improvements in Seismographs with Mechanical Registration. Monthly Weather Review, 1906, vol. xxxiv, pp. 212-217.

The solution then becomes

$$a = K \cos(p\lambda - x) \cos(p\lambda - x) + e^{\lambda c} \cos(p\lambda - x) \cos(p\lambda - x) + \dots \quad (87)$$

where

$$\left. \begin{aligned} a_1 &= \frac{1}{\sqrt{(n^2 - iV)^2 + (2Kp_1)^2}} = \frac{1}{\sqrt{\{j(A/T_0)^2 - 1\}^2 + 4(\kappa T_0/2\pi)^2 (P_1/T_0)^2}} = \frac{1}{\Delta} \\ \sin(\psi_1' - \psi_1) &= \frac{2\kappa p_1}{\sqrt{(n^2 - p_1^2)^2 + (2\kappa p_1)^2}} = \frac{2(\kappa T_0/2\pi)(P_1/T_0)}{\Delta} \\ \cos(\psi_1' - \psi_1) &= \frac{n^2 - p_1^2}{\sqrt{(n^2 - p_1^2)^2 + (2\kappa p_1)^2}} = \frac{(P_1/T_0)^2 - 1}{\Delta} \\ b_1 &= \frac{1}{\sqrt{(n^2 - q_1^2)^2 + (2\kappa q_1)^2}} = \frac{1}{\sqrt{\{(Q_1/T_0)^2 - 1\}^2 + 4(\kappa T_0/2\pi)^2 (Q_1/T_0)^2}} = \frac{1}{\Delta'} \\ \sin(\psi_1' - \psi_1) &= \frac{2(\kappa T_0/2\pi)(Q_1/T_0)}{\Delta'}; \quad \cos(\psi_1' - \psi_1) = \frac{(Q_1/T_0)^2 - 1}{\Delta'} \end{aligned} \right\} \quad (88)$$

with similar forms for the other subscripts; the values of A and A' are evident. And

$$\left. \begin{aligned} K &= A_1 e^{-Kt} \sin(2\pi T/T)(t-t_0); \quad \text{when } K < 2\pi T/T_0 \\ &= e^{-Kt} (A + A' t); \quad \text{when } K = 2\pi T/T_0 \\ &= A_1 e^{m_1 t} + J_2 e^{-m_2 t}; \quad \text{when } K > 2\pi T/T_0 \end{aligned} \right\} \quad (89)$$

where  $J_1, -A_2$ , and  $t_0$  are arbitrary constants to be determined to satisfy the initial conditions; the value of  $2\pi T/T$  is given by equation (37) and the values of  $m_1$  and  $m_2$  by equation (59).

We see therefore that the movements of the pointer will consist of a number of simple harmonic motions of the same periods as the disturbance, but with a difference of phase, and of the proper movement of the pendulum, which is well marked at the beginning of the movement, but dies down more rapidly as  $K$  is larger. Altho we have seen that we can not get a general solution when there is solid friction, as we have when this is absent, nevertheless it seems pretty certain that the effect of solid friction would be to shorten the interval of irregular movement of the pendulum before the regular harmonic movements are established.

#### MAGNIFICATION OF HARMONIC DISTURBANCES.

The magnification of each simple linear harmonic movement is given by the ratio of the amplitude of the pointer to that of the disturbance corresponding to that movement; that is,  $a + C\sqrt{V}$  this becomes

$$W = \frac{a_1 V}{C_1} = \frac{p_1^2 V}{\sqrt{(n^2 - p_1^2)^2 + (2\kappa p_1)^2}} = \frac{V}{\sqrt{\{(P_1/T_0)^2 - 1\}^2 + 4(\kappa T_0/2\pi)^2 (P_1/T_0)^2}} \quad (90)$$

which is the expression we have already found in equation (79).

To determine the magnifying power for tilts, we must compare the maximum angular displacement of the marking lever with the maximum angular tilt of the support. If  $l$  is the length of the long arm of the marking lever, its maximum angular displacement for a particular movement will be  $h/l$  and the maximum tilt will be  $D\sqrt{V}g$ ; the ratio becomes

$$U = \frac{b_1 V g}{h} = \frac{(Q_1/T_0)^2}{\sqrt{\{(Q_1/T_0)^2 - 1\}^2 + 4(\kappa T_0/2\pi)^2 (Q_1/T_0)^2}} \quad (91)$$

here  $Q_1$  is the period of that particular movement of the support.

A glance at equations (88), (90), and (91) shows that in the record the magnification and change of phase of the various harmonic movements of the disturbance are different for different periods, and therefore the curve of the record will not be the same as the

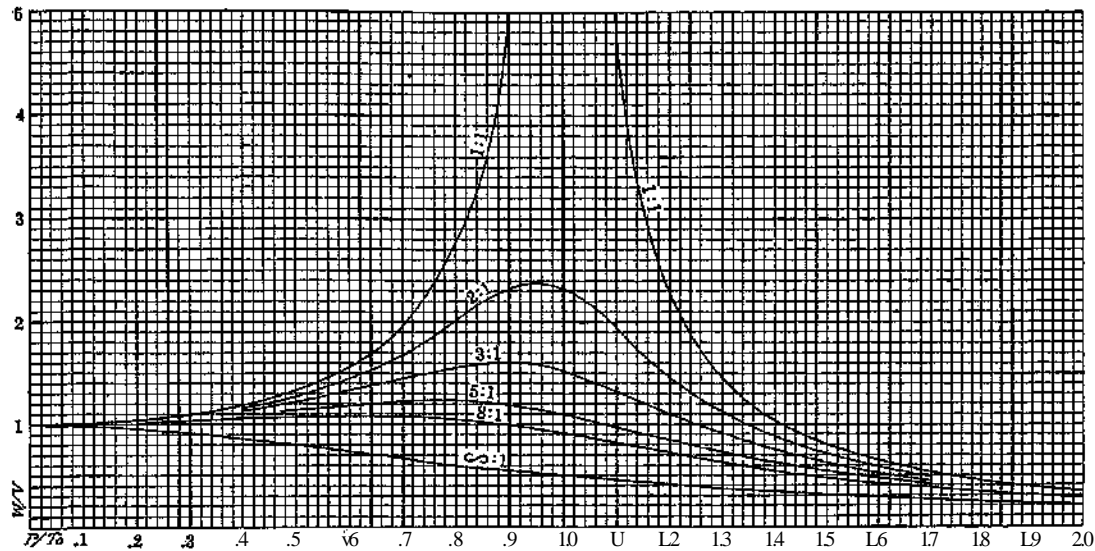

FIG. 47.— Magnifying power of linear displacements.

curve of the disturbance, if the latter consists of movements of more than one period; and it is not possible by increasing  $K$  to equalize the magnification of the movements for different periods and the phase differences, and make the two curves alike; but it might be possible to pick out the different harmonic movements in the record and then

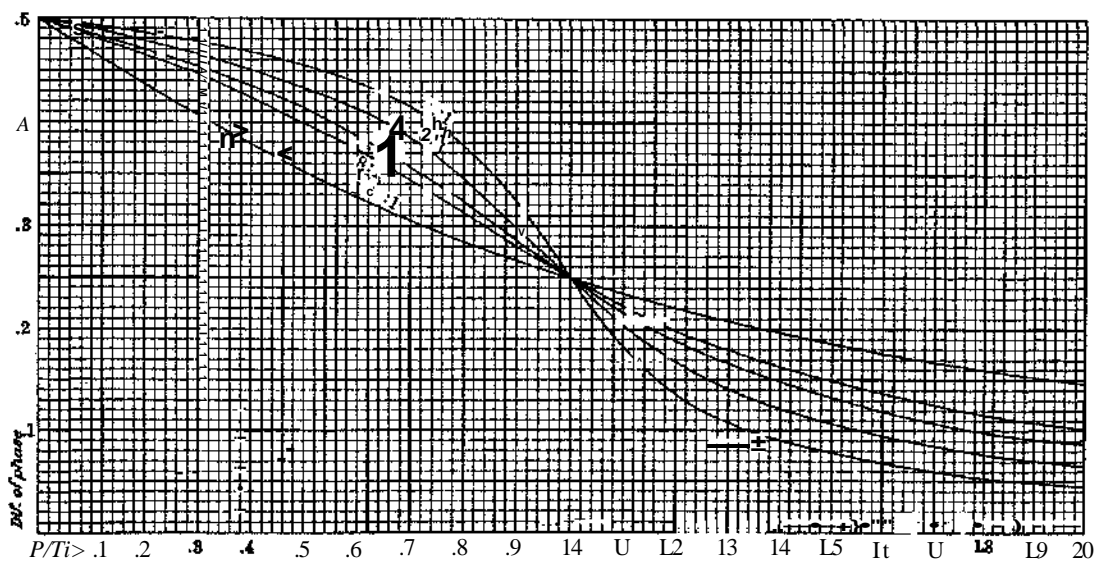

FIG. 48.— Differences of phase for linear displacements.

to calculate the harmonic movements of the disturbance; we could not, however, determine whether these movements were linear displacements or tilts. To make clear the influence of damping, I have, following Professor Wiechert, drawn the diagrams, figures 47 and 48. Figure 47 shows the relative magnifying powers for linear displacements for various values of the damping ratio and for different ratios of the periods of the

disturbance and the free period of the pendulum; the curves are calculated from equation (90). Figure 48 shows the phase differences for the same variables calculated from equation (88).<sup>1</sup> We notice that for values of  $e$  not too large, the magnifying power increases with the ratio of the periods to a maximum and then diminishes indefinitely. The position of the maximum, found by equating to zero the derivative of (90) with respect to  $P/T_0$ , occurs when

$$\left(\frac{P}{T_0}\right)^2 = 1 - 2 \left(\frac{K T_0}{2\pi}\right)^2 Y \quad (92)$$

and its value is

$$W(max) = \frac{V}{\sqrt{1 - (P/T_0)^2}} \quad (93)$$

For small values of  $e$  the magnifying power varies enormously for different periods, becoming very large for periods approaching the free period. Instruments with small damping emphasize certain periods unduly. As we increase  $e$ ,  $W$  becomes more uniform and when  $e$  is about 8:1,  $W$  varies by less than one-tenth of its value for all periods up to the free period, and is very nearly equal to  $V$ . This amount of damping would be excellent, but it would not make the curves of disturbance and record alike, for altho the magnification of the different periods would be practically the same, figure 48 shows that the phase differences would not. Nevertheless this offers great advantages; in the case of nearly simple harmonic movements, which probably occur not infrequently, our record would show the magnifying power without long calculations, whatever be the period, up to the free period; and the record would show directly the relative displacements in different parts of the disturbance, without unduly magnifying certain parts. With this value of the damping ratio the proper movements of the pendulum would be damped out in one or two vibrations. The longer the proper period of the pendulum, the greater the range of periods over which the magnifying power remains nearly constant. This is the principal advantage of long proper periods when recording harmonic disturbances.

For increasing values of  $e$  the position of the maximum moves to the left and becomes zero when  $1 - 2(c^2/27r)^2 = 0$ , which corresponds to  $e = 23:1$ . For values of  $e$  greater than this there is no maximum; the magnification is greatest for infinitely small values of  $P/T_0$  and diminishes for all greater values; when  $e$  becomes  $\infty:1$ ;  $2IT/KT_0$  equals unity, and the instrument is deadbeat;  $W$  is considerably diminished and varies greatly in value.

The magnifying power for tilts is shown in figure 49; it is equal to the variable part of that for displacements multiplied by  $f/i\{Q/T_0\}^2$ . Its value is zero when  $Q/T_0$  is indefinitely small; it increases with this factor and reaches a maximum when

$$\frac{dU}{d(Q/T_0)} = \frac{1}{1 - id \sqrt{K T_0 / 2\pi}} \quad (92a)$$

when its value is

$$U(max) = \frac{\bar{n}}{i} \frac{(Q/T_0)^2}{\sqrt{(Q/T_0)^2 - 1}} \quad (93a)$$

it then diminishes to  $\bar{n}/i$  when  $Q/T_0$  is indefinitely large. The position of the maximum is at  $Q/T_0 = 1$  when  $e = 1$  (*i.e.*,  $K = 0$ ); it moves to the right as  $e$  increases, reaching infinity when  $1 - 2(KT_0/2\pi)^2 = 0$ ; or  $e = 23.1$ . For greater values of  $e$  there is no maximum. There is no value of  $e$  which produces a fairly even degree of magnification for even a

<sup>1</sup> For  $e = 1:1$ , the difference of phase is 0.5 for values of  $P/T_0$  less than 1; and is 0 for values of  $P/T_0$  greater than 1.



small range of values of  $Q/T_0$  when this ratio is not large, except a value large enough to reduce the displacement of the pointer to a small fraction of that of the earth.

The factor independent of the period is  $\bar{n}/i$ ; and this can be increased indefinitely by increasing the number and magnifying power of the levers, and by diminishing  $i$ ;

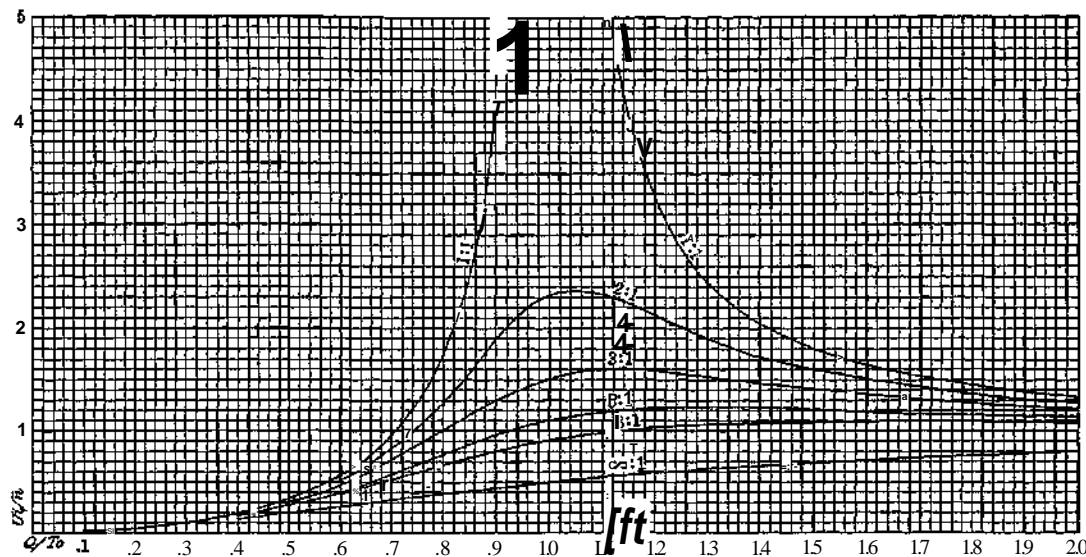

FIG. 49.—Magnifying power for tilts.

we are, however, confronted by the friction of the marking point, which becomes so important as we increase the magnifying power that small tilts are not recorded. But this can be overcome if optical methods of registration are used; and if the friction at the pivots is avoided by methods mentioned further on.

#### MAXIMUM MAGNIFYING POWERS.

It is important to magnify largely the movements of the ground by the seismographs; instruments in present use, which apparently magnify eight or ten times, give sufficiently large records of parts of strong distant earthquakes; but this is principally due to lack of damping and to the fact that the periods of the waves harmonize with the proper periods of the pendulums. If these pendulums were damped to a ratio of 8:1, we should get much smaller records. Let us see how  $V$ , the other factor in the magnifying power of linear displacements, which is independent of the period, can be altered. It might appear that this factor could be increased indefinitely by increasing the number of the multiplying levers, and the ratio of their long to their short arms; but this is not so, even when we neglect the solid friction. The value of  $V$  given in equations (29) becomes, on replacing  $\bar{n}$  and  $L$  by their values,

$$F = \frac{M \bar{n}_1 \bar{n}_2 \cdots \bar{n}_j}{I + n_1^2 I' + n_1^2 n_2^2 I'' + \cdots + (n_1^2 n_2^2 \cdots n_x^2) I^x}$$

where  $x$  is the number of levers; and the subscripts of the  $F$ s are omitted. Let us suppose that the levers are all alike; we may then write (using the same notation as before),  $n_a = n_b = n_c = \cdots = m$ , the multiplying power of each lever, and  $I' = I'' = \cdots = kL$ ; the equation becomes

$$F = \frac{M \bar{n}_1 m^{x-1}}{I + n_1^2 k (1 + m^2 + m^{2*} + \cdots + m^{2*(x-1)})} = \frac{M \bar{n}_1 m^x}{m l j \{ 1 + V \& (m^* - 1) / (m^2 - 1) \}} \quad (94)$$

We can use various values of  $n_x$ , but the best is when  $n_x^2 k (m^{2x} - 1)/(m^2 - 1) = 1$ , which gives for the magnifying power

$$V(max) = \frac{Ml(m^2 - 1)}{2ml - Vky/on^2 - 1 - n^k} \quad (95)$$

$x$  can not be less than 1, and  $m$  is usually much greater, so that the radical never differs much from unity; it can therefore be neglected, and we see that the maximum value of  $V$  is independent of the number of levers used, if we give  $n_x$  its best values. If we use only one lever,  $n_x^2 = l/k$ . This is not always practicable; for instance, for the Bosch-Omori instrument,  $l/k = 220,000$ ;  $\therefore \sqrt{l/k} = 470$ ; and since  $l = 75$  cm.,  $l_2$  becomes 0.15 cm.

On the other hand, we can determine the best numbers of levers to use by determining the maximum value of  $V$  for variations of  $x$  in equation (94). This gives

$$x = \frac{1}{2 \log m} \log \frac{m^2 - 1 - n_x^2 k}{n_x^2 k} \quad V(max) = \frac{Ml(m^2 - 1)}{2ml - Vky/on^2 - 1 - n^k} \quad (96)$$

For the Bosch-Omori instrument,  $n^k = \sqrt{l/k}$ , about, and with  $m = 10$ ,  $x$  becomes 2.17, and the maximum value of  $V$  is 78. If we omit  $n_x^2 k$  and 1 in comparison with  $m^2$ , the above expressions become

$$x = \frac{1}{2 \log m} \log \frac{m^2}{n_x^2 k} = \frac{1}{2 \log m} \log \frac{l^2}{n_x^2 k} \quad V(max) = \frac{Ml}{2lVkn} \quad (97)$$

$k$  and  $l$  are not independent; replace  $k$  by its value,  $l^2/n^2$ . The moment of inertia,  $I$ , of each lever is principally that of the long arm, as the short arm counts but little; if we double the length of the lever, we must at least quadruple its mass to keep it strong enough; we may therefore suppose its moment of inertia equal to  $I^2$ ; introducing this into the values of  $x$  and of  $V(max)$  we get

$$x = \frac{1}{2 \log m} \log \frac{JL}{n^2 I^2} \quad V(max) = \frac{Ml}{2WJ} \quad (98)$$

and we see that we get a greater multiplying power, if we use short and light levers, rather than a smaller number of longer and correspondingly heavier ones,  $J/I$  depends on the density and distribution of material in the levers, and should be made as small as possible.  $Ml/V \sim I$  varies proportionally with  $\sqrt{M}$ , but very little with  $l$ , if  $l$  is several times as large as the radius of gyration of the pendulum about its center of gravity; therefore  $V(max)$  can be increased by increasing  $M$ , rather than by increasing  $l$ .

We have not considered the solid friction of the marking point, which, as has been shown on page 171, increases the minimum acceleration which can be registered in the proportion of the multiplying power of the levers, and is in general so great that it exerts a controlling influence over the possible magnifying power of the instrument. The investigation, therefore, does not apply directly to seismographs with mechanical registration, but would apply to instruments of the same form if direct photographic registration, as in the Milne instrument, were used at the end of the last lever.

This suggests a method of optical registration by which very high magnification can be obtained without placing the recording paper far from the instrument. In the usual optical method the light is reflected directly from a mirror carried by the pendulum; but if the mirror is carried on the axle of a magnifying lever, the angle thru which it turns can be increased very greatly (fig. 50). The magnifying power becomes

$$V = \frac{2 d\theta'}{ze} = \frac{2 Ml n_1 d}{I + n_1^2 I'} \quad (99)$$

where  $d$  is the distance from the mirror to the recording paper. The best value of  $n^\wedge$  is  $l/l'$ , and the corresponding magnification is  $Mld^\wedge/lP$ . As an example, suppose the pendulum consists of a mass of 10 kg. placed at a distance of 20 cm. from the axis of rotation;  $l$  would be  $4 \times 10^6$  cm.<sup>2</sup>gm.; let  $l'$  be  $4 \times 10^2$  cm.<sup>2</sup>gm.; a little greater than that of the lever of the Bosch-Omori instrument; then  $l/l' = 10^4$ , and  $^\wedge = 100$ . If  $d = 100$  cm., the magnifying power becomes 500. If we desire any other magnification, we can

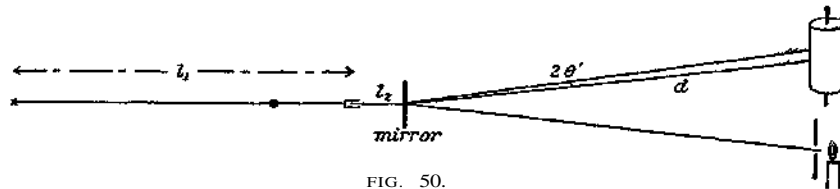

FIG. 50.

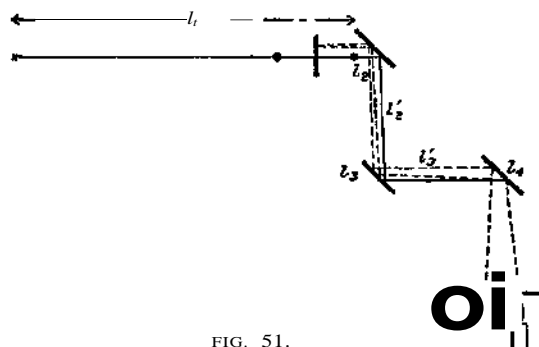
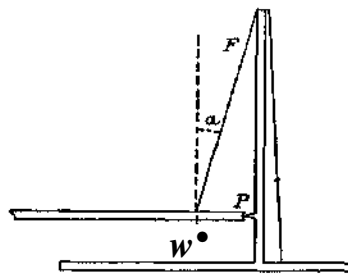

FIG. 51.



Via. 52.

select the proper values of  $M$ ,  $l$ ,  $n_x$  and  $d$  to give it. If a very high value of  $V$  is desired, the arrangement shown in figure 51 can be used. The light is reflected twice from each mirror and at each reflection is deflected thru twice the angle of rotation of the mirror. The magnification becomes

$$V = \frac{Mid4M(1+m+m^2+\dots+m^{x-1})}{I+nl'l(1+m^2+\dots+m^{2x-1})} \sim \frac{Mid4n_l(m+1)(m^x-1)}{(m^2-1)+n^2P(m^{2x}-1)} \quad (100)$$

$d$  is the distance from the last mirror, following the course of the light, to the drum. We have neglected the angle thru which the light is turned by the mirror on the pendulum, for with any fairly large value of  $n_\pm$  it is very small as compared with the total deflection of the light. The best value of  $n_x$  is given by

$$n_1^{2j}/(2^j-1) = (w-1), \text{ or } w \ll (J/l')(2^j-1)/(m^{2x}-1)$$

and

$$V(max) = \frac{2Mid}{Vl^7} \sqrt{\frac{r-1}{m-1} \frac{a}{m^x+1}} \quad (101)$$

The radical is largest when  $x$  is large, but it does not vary much; when  $x = 1$ , it equals 1; when  $x = 2$ , it equals  $\sqrt{(m-1)^2/(m^2+1)}$ , which equals 1.095 if  $m = 10$ ; and when  $x \rightarrow \infty$  and  $m = 10$  it equals 1.111; so that very little is gained by increasing the number of levers, except to get a proper value of  $n_x$  more easily. If  $M = 10,000$  gm.,  $l = 20$  cm.,  $d = 100$  cm.,  $l = 4 \times 10^8$ ,  $l' = 4 \times 10^2$ ,  $x = 1$ ; then  $n_l = 100$ ; and  $V(max) = 2MM/4 \times 10^4 = 1000$ . If we make  $x = 2$ , and  $m = 10$ ; then  $n_x = 10$  and  $V(max) = 1090$ .

If the value of  $n_x$  were fixed, we should find for the best number of levers to use, and the corresponding maximum magnification

$$x = \frac{\log m \left( 1 + \sqrt{1 + \frac{I'}{n_l^2}} \right)}{\log m \left( 1 + \sqrt{1 + \frac{I'}{n_l^2}} \right)} \quad m_1 l' + \sqrt{I l' (m^x - 1)}$$

Taking  $n_t = 50$  and the rest of the data as before, we get  $x = 1.32$ , and  $V(max) = 1000$ , the same value as before; but if we make  $x = 1$ , the nearest practical value, we find  $V(max) = 800$ , which is not very much less. By using steel ribbon for connectors at the axes, and between the pendulum and the levers, or by using one of the devices suggested by Dr. C. Mainka,<sup>1</sup> we could easily get rid of solid friction, and realize the theoretical values above.

#### SUSPENSIONS OF HORIZONTAL PENDULUMS.

There are 4 forms of suspension for horizontal pendulums: (1) The Gray suspension (figure 52); a horizontal beam carrying a weight presses against a point, and is supported by a tie thru its center of gravity. Let  $F$  be the tension of the tie,  $P$  the pressure at the pivot, supposed horizontal, and  $W$  the weight; for equilibrium, these 3 forces must pass thru the same point and we must have

$$F \cos \alpha = W, \text{ or } F = W / \cos \alpha \quad F \sin \alpha = P = W \tan \alpha \quad (103)$$

The friction at  $P$  depends upon the pressure there; and we see it is less as  $\alpha$  is smaller. This can be brought about either by putting the weight closer to the pivot or by length-

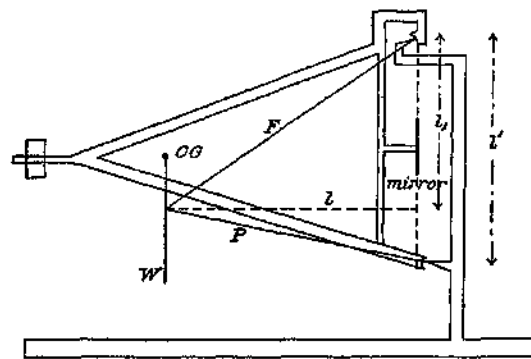

FIG. 53.

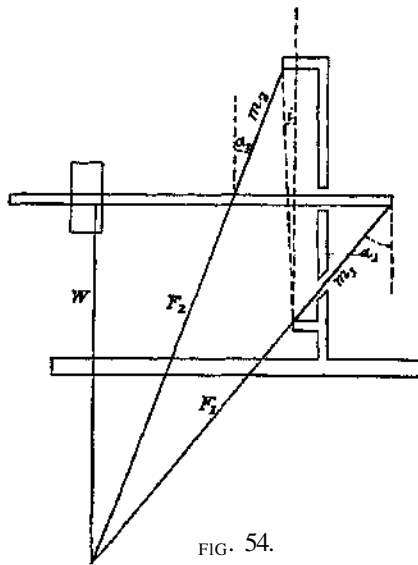

FIG. 54.

ening the distance between the two points of support. By the first method we shorten the distance of the CG from the axis of rotation, and we change the values of the constants in the general equation; by the second method, these constants are not affected.

(2) The Ewing suspension: this differs from the preceding only in replacing the pivot by a thin steel ribbon, thus doing away with the friction at this point. The horizontal beam is extended beyond the axis of rotation and is fastened to the axis by a steel ribbon. Professor Ewing suggested that a steel pin occupying the position of the axis of rotation, and connected firmly with the support, should pass through a slot in the beam, and thus prevent lateral movements of this part of the beam; but this pin introduces some friction. This use of a steel ribbon has only lately been put into practice (by Professor Wiechert).

(3) The von Rebeur-Paschwitz suspension (figure 53): the points of support are sharp steel points resting in agate cups, the upper one being turned to produce a supporting force. The three forces  $P$ ,  $F$ , and  $W$  must meet in a point, which is vertically below or above the center of gravity.

<sup>1</sup> Kurze Uebersicht tiber die modernen Erdbeben-Instrumente. Die Meehaniker, XV Jahrgang, 1907. Since the above was written Prof. C. F. Marvin has suggested a practically similar method for increasing the magnifying power. "A Universal Seismograph for Horizontal Motion." Monthly Weather Rev., 1907, vol. XXXV, pp. 522-534.

The two points of support and the center of gravity lie in a vertical plane when the instrument is in equilibrium. The direction of the forces  $F$  and  $P$  can be somewhat controlled by the direction of the points and of the cups, but friction will alter the direction of the forces to some extent. Usually a plane surface is used instead of one of the cups, which renders it unnecessary that the distance between the points should be exactly the same as the distance between the centers of the cups. Taking moments about the points of support, we find

$$F = \frac{WV}{l} + T \quad P = \frac{TrV}{l} + p \quad (104)$$

where the meanings of the letters are shown in the figure. These forces become equal when  $\alpha = l/2$ , and they make equal angles with the vertical; they then pass thru the  $CG$ ; they become smaller as  $V$  becomes larger in comparison with  $l$ . When the lower point presses against a vertical plane agate surface, the direction of  $P$  is horizontal,  $Z_x = l'$ , and

$$F = \frac{WVl'^2 + P}{l'} \quad p = \frac{Wl'}{l'} \quad (105)$$

$Ul = l', F = lAIP.$

(4) The Zöllner suspension (figure 54); the beam is supported by two wires  $m_1$  and  $m_2$  fastened to the support, one above and one below the beam. The direction of the forces must pass thru the vertical thru the  $CG$  of the beam; and therefore the angle  $a_t$  must be greater than the angle  $\alpha_s$ ; but the values of these angles can only be found thru an equation of the fourth degree, and can only be expressed by a very complicated expression. The Zöllner suspension has the great advantage of not having any pivots, and therefore, if an optical method of registration is used, there is no solid friction. For very slow movements it would answer very well, but for more rapid movements its motion is too complicated. It can have linear displacements parallel with and at right angles to the beam, as well as a rotation around a nearly vertical axis at right angles to the beam. The linear movement parallel with the beam also caused a vertical movement of the mass. These various movements, themselves the effects either of linear displacements or tilts of the support, could not be separated from each other by a single registration; and it would be impossible to interpret the record. To avoid these complications Prince Galitzin has proposed to have the beam press by a point against an agate plate placed close to the axis of rotation, and he has shown that even when the pressure is very light, the device will prevent the first two movements. Another way would be to fasten the point of the beam where it crosses the axis of rotation by guy-wires. They would prevent it from moving out of this position, but would not interfere with small rotations. Prince Galitzin has suggested this method for other instruments. Either of these devices prevents all relative motion except a simple rotation, without introducing friction, and the theory of the instrument then becomes the same as that already given for the Gray or von Rebeur-Paschwitz forms. All instruments of the Zöllner type in use up to the present time have no device to prevent the complicated motions, and in attempting to interpret the records of the California earthquake as given by instruments of this type, we must assume that only rotations take place.

#### THE VERTICAL PENDULUM.

Let us now consider the movements of an ordinary vertical pendulum whose support is subjected to an earthquake disturbance producing the three displacements,  $\xi$ ,  $\eta$ ,  $\zeta$ , and the three rotations,  $\alpha_x$ ,  $\alpha_y$ ,  $\alpha_z$ .

Let  $O$ , figure 55, be the origin of coördinates and let  $X$ ,  $Y$ , and  $Z$  be the coördinates of the point of support; then if  $l$  is the distance from the point of support to the  $CG$ , the

coordinates of the  $CG$  will be  $X, Y, Z$ — $I$  In the figure, we have omitted the linear displacements for the sake of clearness, and have represented the  $CG$ , as not moved by the rotations; this introduces no error as the angular rotations are all given their proper values. As in the case of the horizontal pendulum, let us refer the motion of the pendulum to three axes fixed in the pendulum and moving with it; and which are principal axes of inertia. Axis (3) lies in the line from the point of support to the  $CG$ .

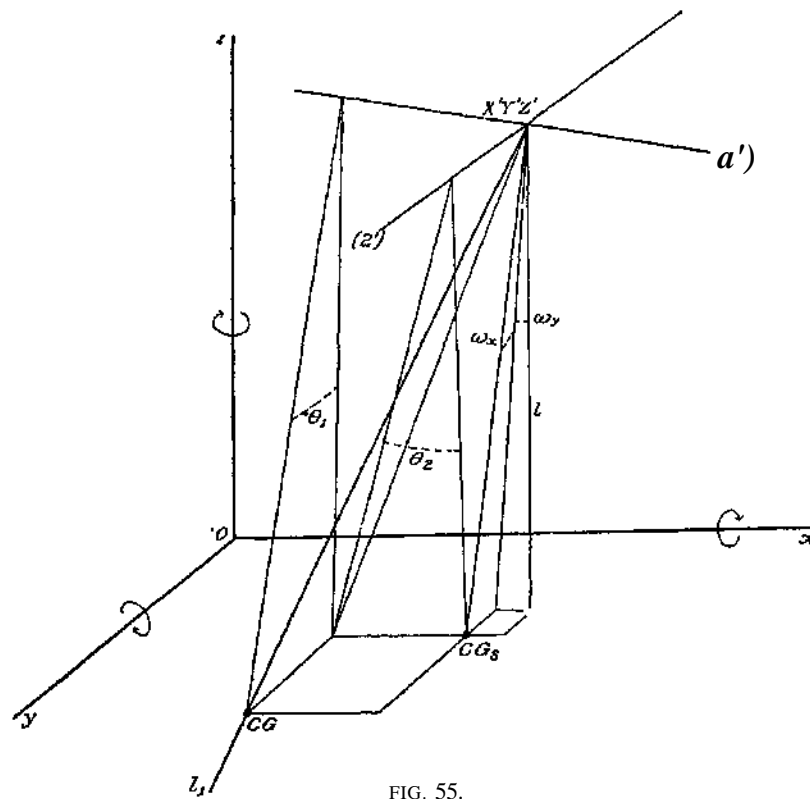

FIG. 55.

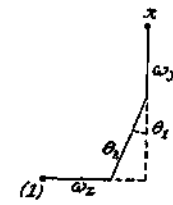

FIG. 56.

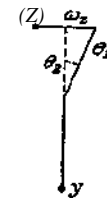

FIG. 57.

Axes (1) and (2) are the rotated positions of lines at right angles to (3) and passing thru the  $CG$ , which were, before rotation, parallel to the fixed axes of coordinates. Axes parallel with these and passing through the point of support have primes.

We assume that there is no rotation around the axis (3). If the pendulum were supported at a mathematical point, no such rotation could be set up as the direction of the force there passes through the axis; practically the support is a small surface and it might be possible for a small moment to exist around axis (3), but it would be so small that we may safely neglect it.

What is actually measured is the displacement of the  $CG$  relative to the  $CG$ ; that is, the angles  $\delta_1$  and  $\delta_2$ ; we must therefore form our equations of motion connecting  $\theta_1$  and  $\theta_2$  with the displacements and rotations. Using the same notation as before, except that  $\delta_x$  and  $\delta_y$  are used for the angular displacements of the  $CG$  relative to the  $CG$ , we follow the same method to develop the equations of the pendulum.

The linear accelerations of the  $CG$  are given by equations (4), and Euler's equations of angular accelerations around the  $CG$  are

$$I_1 \frac{d^2(\theta_1 + \omega_1)}{dt^2} = A \quad I_2 \frac{d^2(\theta_2 + \omega_2)}{dt^2} = B \quad (106)$$

where  $A$  and  $B$  are the moments of the forces around the axes thru the  $CG$  parallel with (1') and (2'). As before, we have neglected the term containing the product of the angular velocities, as  $a > \delta$ , and therefore its derivatives are practically zero. Let the point of contact of the pendulum and the indicator be at a distance  $l_x$  from the point of support of the former. The indicator may be a vertical lever, in which case  $f_1$  and  $f_2$  are the two components of the reaction; or it may be made up of two horizontal levers with their short arms at right angles to each other, and crossing at the point of contact with the pendulum; in this case  $f_1$  and  $f_2$  are the normal components of the force against each lever, and the frictional components parallel to the levers are neglected as in the case of the horizontal pendulum.

The moments of the forces around the  $CG$  are

$$A = -F_2 l + f_2 (l_2 - l) \quad B = F_1 l - f_1 (l_1 - l) \quad (107)$$

$F_1$  and  $F_2$  are given by two equations similar to equation (10); the cosines of the angles between the axes are obtained from the figures 56 and 57, in the same way as in the case of the horizontal pendulum (p. 152).

$$\left. \begin{aligned} \cos(x, 1) &= \cos(\alpha + \omega_2 t) = \cos(\alpha + \theta_2) \\ \cos(y, 1) &= \sin(\omega_2 t) = \sin(\theta_2) \\ \cos(z, 1) &= -\sin(\alpha + \theta_2) \end{aligned} \right\} \quad (108)$$

$$\left. \begin{aligned} \cos(x, 2) &= -\sin(\omega_2 t) = -\sin(\theta_2) \\ \cos(y, 2) &= \cos(\alpha + \theta_2) \\ \cos(z, 2) &= \sin(\alpha + \theta_2) \end{aligned} \right\} \quad (109)$$

We have

$$x = \xi + (Z - l) \omega_2 \quad y = \eta + X \omega_2 - (Z - l) \omega_2 + l \theta_2 \quad z = \zeta + Y \omega_2 - X \omega_2 \quad (110)$$

and

$$\left. \begin{aligned} \frac{d^2 x}{dt^2} &= \frac{d^2 \xi}{dt^2} + (Z - l) \frac{d^2 \omega_2}{dt^2} - Y \frac{d^2 \omega_2}{dt^2} - l \frac{d^2 \theta_2}{dt^2} \\ \frac{d^2 y}{dt^2} &= \frac{d^2 \eta}{dt^2} + X \frac{d^2 \omega_2}{dt^2} - (Z - l) \frac{d^2 \omega_2}{dt^2} + l \frac{d^2 \theta_2}{dt^2} \\ \frac{d^2 z}{dt^2} &= \frac{d^2 \zeta}{dt^2} + Y \frac{d^2 \omega_2}{dt^2} - X \frac{d^2 \omega_2}{dt^2} \end{aligned} \right\} \quad (111)$$

and therefore

$$\left. \begin{aligned} F_x &= M \frac{d^2 x}{dt^2} - f_x = M \left\{ \frac{d^2 \xi}{dt^2} + (Z - l) \frac{d^2 \omega_2}{dt^2} - Y \frac{d^2 \omega_2}{dt^2} - l \frac{d^2 \theta_2}{dt^2} \right\} \\ F_y &= M \frac{d^2 y}{dt^2} - f_y = M \left\{ \frac{d^2 \eta}{dt^2} + X \frac{d^2 \omega_2}{dt^2} - (Z - l) \frac{d^2 \omega_2}{dt^2} + l \frac{d^2 \theta_2}{dt^2} - \frac{f_y}{M} \right\} \\ F_z &= M \frac{d^2 z}{dt^2} + Mg = M \left\{ \frac{d^2 \zeta}{dt^2} + Y \frac{d^2 \omega_2}{dt^2} - X \frac{d^2 \omega_2}{dt^2} + g \right\} \end{aligned} \right\} \quad (112)$$

Putting the values of the cosines from equations (108) and (109) in equation (10), we get

$$F_l = F_x \cos(\alpha + \theta_2) + F_y \sin(\theta_2) + F_z \sin(\alpha + \theta_2) \quad (113)$$

Introducing the values of  $F_x$ ,  $F_y$ , and  $F_z$  into these equations, and then the values of  $J_1$  and  $F_3$  into equation (107), and then the values of  $A$  and  $B$  thus obtained into equations (106), we get for our equations of motion

$$I_1 \frac{d^2(\theta_1 + \omega_1)}{dt^2} = Ml \left[ \left\{ \frac{d^2\xi}{dt^2} + (Z-l) \frac{d^2\omega_x}{dt^2} - Y \frac{d^2\omega_y}{dt^2} - l \frac{d^2\theta_2}{dt^2} - \frac{f_x}{M} \right\} \omega_x - \left\{ \frac{d^2\eta}{dt^2} + X \frac{d^2\omega_x}{dt^2} - (Z-l) \frac{d^2\omega_y}{dt^2} + l \frac{d^2\theta_1}{dt^2} - \frac{f_y}{M} \right\} - l \left\{ \frac{d^2\xi}{dt^2} + Y \frac{d^2\omega_x}{dt^2} - X \frac{d^2\omega_y}{dt^2} + g \right\} (\omega_x + \theta_1) \right] + f_2(l_1 - l) \quad (114)$$

$$I_2 \frac{d^2(\theta_2 + \omega_2)}{dp} = Ml \left[ \left\{ \frac{d^2\xi}{dt^2} + (Z-l) \frac{d^2\omega_x}{dt^2} - \frac{d^2\eta}{dt^2} - l \frac{d^2\theta_2}{dt^2} - \frac{f_x}{M} \right\} + \left\{ \frac{d^2\eta}{dt^2} + X \frac{d^2\omega_x}{dt^2} - (Z-l) \frac{d^2\omega_y}{dt^2} + l \frac{d^2\theta_1}{dt^2} - \frac{f_y}{M} \right\} \omega_x - \left\{ \frac{d^2\xi}{dt^2} + Y \frac{d^2\omega_x}{dt^2} - X \frac{d^2\omega_y}{dt^2} + g \right\} (\omega_y + \theta_2) \right] - Mh - t \quad (115)$$

If we take the point of support as our origin, the first equation becomes (since  $X = Y = Z = 0$ , and writing  $I_a = I_x + Ml^2$ ),

$$I_a \frac{d^2\theta_1}{dt^2} = Ml \left[ \left\{ \frac{d^2\xi}{dt^2} - l \frac{d^2\theta_2}{dt^2} - \frac{f_x}{M} \right\} \omega_x - \left\{ \frac{d^2\eta}{dt^2} + g \right\} (\omega_x + \theta_1) \right] + f_2 l_1 - I_1 \frac{d^2\omega_1}{dt^2} \quad (116)$$

In this equation we have assumed that  $\nu = 1/2$ . The friction at the point of contact makes it impossible to evaluate the exact value of  $f$ ; it is, moreover, not large when the indicator is light; and these assumptions are always very nearly true. By omitting some of these terms as negligible and not considering the reaction of the indicator, and making the proper changes of notation, this equation becomes equation (81) of Professor Wiechert. If we take the original position of the  $CG_S$  as our origin, we have  $X=Y=Z-l=0$ ; and the equations become still simpler, namely,

$$\begin{aligned} I_{(1)} \frac{d^2\theta_1}{dt^2} &= Ml \left[ \left( \frac{d^2\xi}{dt^2} - l \frac{d^2\theta_2}{dt^2} - \frac{f_x}{M} \right) \omega_x - \left( \frac{d^2\eta}{dt^2} + g \right) (\omega_x + \theta_1) \right] + f_2 l_1 - I_1 \frac{d^2\omega_1}{dt^2} \\ I_{(2)} \frac{d^2\theta_2}{dt^2} &= Ml \left[ \left( \frac{d^2\xi}{dt^2} + \left( \frac{d^2\eta}{dt^2} + l \frac{d^2\theta_1}{dt^2} - \frac{f_x}{M} \right) \omega_x - \left( \frac{d^2\xi}{dt^2} + g \right) (\omega_y + \theta_2) \right) - f_2 U - I_2 \frac{d^2\omega_2}{dt^2} \right] \end{aligned} \quad (117)$$

where we have also put  $j = 1$ . These equations reduce to Prince Galitzin's equation (99), on omitting certain terms and with proper changes of notation.

We can simplify further by omitting some of the terms;  $d^2\xi/dt^2$  can be neglected in comparison with  $g$ , as on page 154; the terms multiplying  $\omega_x$  represent the moment around (1) of the forces parallel with  $x$ , and have a value on account of the very small angle between them. These terms are very small in comparison with the terms not containing  $\omega_x$ , and may be omitted; omitting also the terms  $I^w/di^2$  and  $I_2 d^2\omega_2/dt^2$  for reasons given on page 154, our equations become

$$I_{(1)} \frac{d^2\theta_1}{dt^2} = -Ml \left\{ \frac{d^2\eta}{dt^2} + g(\omega_x + \theta_1) \right\} + f_2 l_1 \quad \text{and} \quad I_{(2)} \frac{d^2\theta_2}{dt^2} = -Ml \left\{ \frac{d^2\xi}{dt^2} + g(\omega_y + \theta_2) \right\} - f_2 U \quad (H8)$$

With these simplifications we see that the component movements of the pendulum in two directions at right angles are just the same as tho there were two simple pendulums each constrained to move in one vertical plane.

We must now substitute the values of  $f_2$  and  $j$  from the equations of the indicators, equation (22).

With the same assumptions made there, these equations are

$$I_{(1)} \frac{d^2\theta_1'}{dt^2} = -f_2' l_1' \quad \text{and} \quad I_{(2)} \frac{d^2\theta_2''}{dp} = -f_2'' U \quad (119)$$



We suppose that the pivots of the indicator lie on the positive sides of the axes of  $x$  and  $y$  respectively. These equations refer to horizontal indicators with vertical axes of rotation; the primes and seconds refer to the two indicators. If, as in the Vicentini pendulum, the first multiplying lever is vertical; then  $l_{(3)'} = l_{(g)''}$ ;  $b_{s'}$  becomes  $0$ ; and  $b_{s''}$  becomes  $l_{2''}$ ; with these changes equations (119) still hold. Assume that  $l_{ar} = l_1$  and  $l_{j'} = l_2$ ; write  $b_{s'} = -n' b_{s''} = -r_1' e_v$  where  $r_1' = l_1 l_2$  and  $r_1'' = l_1 l_2$ ;  $Z_1'$  and  $Z_2''$  are the lengths of the short arms of the indicators. Remembering that  $l_2 = -f_2' r_1$ , and  $l_1 = -f_1' r_2$ , and substituting in equation (118) the values of  $l_{ar}$  and  $l_{j'}$  from equation (119), we get

$$(J_{(u)} + n'^2 J_{(s)'}) \frac{d^2 \theta_1}{dt^2} = -Ml \left\{ \frac{d^2 \eta}{dt^2} + g(\omega_x + \theta_1) \right\} \quad (J_{(v)} + n''^2 J_{(s)''}) \frac{d^2 \theta_2}{dt^2} = JfZ \left\{ \frac{d^2 \xi}{dt^2} - g(\omega_y + \theta_2) \right\} \quad (120)$$

The second equation becomes identical with equation (23) of the horizontal pendulum if we replace  $cPO/dt^2$  by  $d^2 \xi/dt^2$ , and  $b_2$  by  $l_2$  and shows that the actions of the two types of instruments are the same, but that, other terms in the equations being equal, the force of restitution of the horizontal pendulum is only  $i$  times as great as that of the vertical pendulum. The first equation differs only in that  $d^2 v/dt^2$  has a negative sign; this arises from the fact that a positive acceleration of  $v$  causes a negative acceleration of  $\theta_1$  whereas a positive acceleration of  $\xi$  causes a positive acceleration of  $\theta_2$ ; which is also true of the horizontal pendulum pointing in the positive direction of  $y$ . This difference causes no confusion in practice. On introducing terms for viscous damping and solid friction, we obtain equations exactly like (25) and on passing to the recording point we get equations like (26). Therefore all that has been developed regarding the horizontal pendulum — the methods of determining the constants, the magnifying power for linear displacements and tilts, and the interpretation of the record — applies equally well to the simple vertical pendulum, if we replace  $i$  by 1.

#### THE INVERTED PENDULUM.

The inverted pendulum consists of a mass balanced on a point so that its  $CG$  is vertically over the point. This position is rendered stable either by springs or by a second pendulum hanging immediately above, the two being so connected that the points of contact suffer equal displacements, and their "weights and lengths being so adjusted that the total force arising from a displacement tends to bring the system back to its original position.

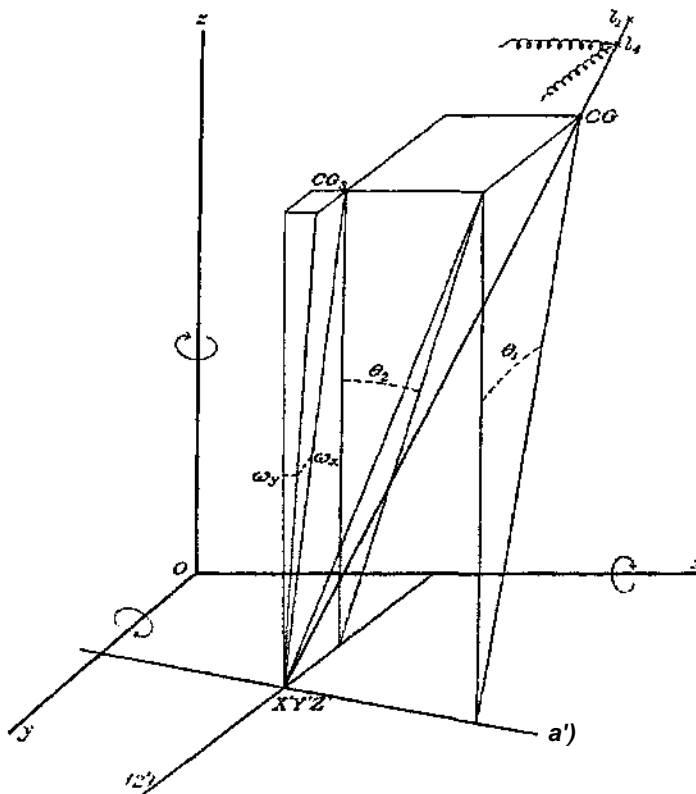

FIG. 58.

This form was originally suggested by Professor Ewing,<sup>1</sup> and the second type above mentioned is called "Ewing's duplex pendulum." A rod attached to the upper pendulum records on smoked glass through a multiplying lever, usually multiplying four times. The glass does not move and there is no arrangement for recording the time. The record of movement is superposed upon itself and is usually difficult to interpret. Several of these instruments were working at the time of the California earthquake, and their diagrams are reproduced in Seismograms, Sheet No. 3.

Lately, Professor Wiechert has greatly improved the inverted pendulum.<sup>2</sup> He has made it very heavy, 1000 kg. or more, in order that he might magnify the motion several hundred times and still not have the movement too much affected by the solid friction of the indicator. He has added a strong viscous friction so as to damp out the proper period of the pendulum and has thus produced a very efficient instrument.

To keep the pendulum in stable equilibrium, springs are attached to a point of the pendulum distant  $Z_4$  from its point of support. The forces thus introduced are proportional to the displacement; let us represent these forces brought into play by positive angular displacements,  $\delta_x$  and  $\delta_y$  around the axes (1) and (2) respectively, by  $v_1 \delta_1$  and  $-v_2 \delta_2$ ;  $v_1$  and  $v_2$  would in general have about the same values.

The equations of linear accelerations become

$$M \ddot{x} = F_x + f_x - v_2 \delta_2 \quad M \ddot{y} = F_y + f_y + v_1 \delta_1 \quad M \ddot{z} = F_z - Mg \quad (121)$$

The moments become

$$A = F_z l - Mk - T - uM(I, -I) \quad J_3 = -FJ + A(I, -I) - V\delta_4 (J_4 - V) \quad (122)$$

The cosines of the angles between the moving and fixed axes are the same as for the vertical pendulum, equations (108) and (109). The values of the coördinates of the *CG* ( $x, y, z$ ) are also the same as those given in equation (110), with the sign of  $I$  reversed. Carrying thru the same operations as before, making the original position of the *CG* the origin of coördinates and omitting the negligible terms, we arrive at the equations

$$\begin{aligned} I_{(1)} \frac{d^2 \theta_1}{dt^2} &= Ml \left\{ \frac{d^2 \xi}{dt^2} + g \omega_x - \left( \frac{v_1 l_1^2}{Ml} - g \right) \theta_1 \right\} - f_2 l_1 \\ I_{(2)} \frac{d^2 \theta_2}{dt^2} &= -Ml \left\{ \frac{d^2 \xi}{dt^2} - g \omega_y + \left( \frac{v_2 l_2^2}{Ml} - g \right) \theta_2 \right\} + f_1 l_1 \end{aligned} \quad (123)$$

If there is no disturbance  $d^2 y/dt^2$ ,  $d^2 \xi/dt^2$ ,  $\omega_x$  and  $\omega_y$  are all zero, and in order that the equilibrium should be stable, we must have  $v_1 l_1^2/Ml > g$ , and  $v_2 l_2^2/Ml > g$ . Introducing the values of  $f_x$  and  $f_y$  from equations (119), dividing by  $[I_{(1)}]$ ,  $[I_{(2)}]$ , and writing  $[I_{(1)}]/Ml = L_1$ ,  $[I_{(2)}]/Ml = L_2$ , we find

$$L_1 \frac{d^2 \theta_1}{dt^2} + \left( \frac{v_1 l_1^2}{Ml} - g \right) \theta_1 = 0 \quad L_2 \frac{d^2 \theta_2}{dt^2} - \left( \frac{v_2 l_2^2}{Ml} - g \right) \theta_2 = 0 \quad (124)$$

After adding damping and frictional terms to these equations, they differ from equation (25) only in some of the signs (which is a matter of notation), and in the factor multiplying the angular displacement. If we replace  $(v_1 l_1^2/Ml - g)/g$  of equations (124) by  $i$  they become equivalent to equation (25), and on passing to the marking points, we get equations equivalent to (26). Therefore all the characteristics of the horizontal pendulum and the interpretation of its record may be applied to the inverted pendulum if we suppose  $\%$  in the former to be replaced by  $(v_1 l_1^2/Ml - g)/g$ .

<sup>1</sup> Transactions Seismological Society of Japan, 1882, vol. V, p. 89; and 1883, vol. VI, p. 19.

\* Ein astatische Pendel hoher Empfindlichkeit zur mechanischen Registrierung von Erdbeben. E. Wiechert, Gerland's Beiträge zur Geophysik, 1904, vol. VI, pp. 435-450.

## SEISMOGRAPHS FOR VERTICAL MOVEMENTS.

The older Italian form of instrument for showing vertical movements was simply a weight hung by a spiral spring, which would be set in motion by any vertical movement of the earth. Palmieri arranged it so that a very small displacement was sufficient to close an electric circuit and thus record a disturbance. Cavalleri added a magnifying lever, which measured the movement of the weight. However, the period of such an instrument would be short unless the spring were inordinately long, and a second form has been devised to obtain a larger period in a smaller compass. This consists of a horizontal bar, pivoted at one end and carrying a weight at the other; it is supported by a spring attached to an intermediate point of the bar.

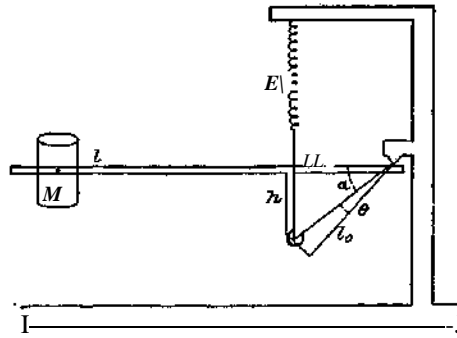

FIG. 59.

This form of instrument was devised by Thomas Gray.<sup>1</sup> Professor Ewing<sup>2</sup> suggested that the point of support of the spring be below the bar, thus increasing the period for a given strength of spring.

Let  $E$  be the force of the spring when the pendulum is at rest; and let  $p$  be the variation of this force for a unit stretch of the spring; then for equilibrium (see figure 59),

$$fl_A - Mgl = 0 \quad \text{or} \quad El_0 \cos a - Mgl = 0 \quad (125)$$

and when the pendulum is displaced thru an angle  $\theta$  the additional moment will be

$$\frac{d}{da} (El_0 \cos a) \theta = k \frac{dh}{da} B - El_0 \sin a \cdot \theta = (pU - Eh) \theta \quad (126)$$

and the free period of vibration will be

$$T_0 = 2\pi \sqrt{\frac{I}{pZ^2 - Eh}} = 2\pi \sqrt{\frac{I}{h}(ph^3 - Mglh)} \quad (127)$$

We can therefore make the period as long as we choose by selecting suitable values of  $p$ ,  $l$ ,  $M$ ,  $I$ , and  $h$ .

The next modification for increasing the period of the pendulum is described by Prof. John Milne.<sup>3</sup> The supporting spring is a curved flat steel band; and the compensation is obtained by a special spring fastened immediately above the pivot to an arm connected rigidly with the bar of the pendulum. As long as the pendulum is at rest this spring has no effect, but when the bar is raised or lowered, the spring exerts a moment tending to increase the displacement; this is equivalent to reducing the force of restitution due to the main supporting spring, and therefore increases the period of the pendulum. The principle here made use of seems to have been first suggested by Professor Ewing.\* Let

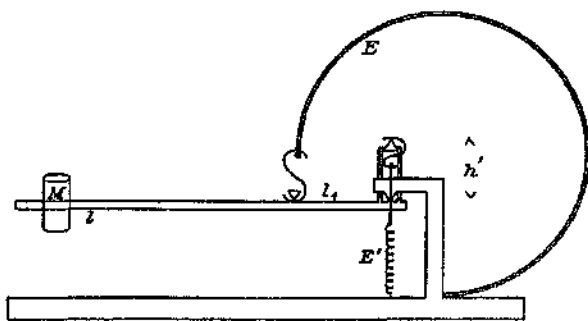

FIG. 60.

Let

<sup>1</sup> On a Seismograph for Registering Vertical Motion, Trans. Seism. Soc. Japan, 1881, vol. Hi, p. 137.  
A similar form is reported to have been used at Comrie, Scotland, in 1841.

<sup>2</sup> A Seismometer for Vertical Motion. Same, p. 140.

<sup>3</sup> The Gray-Milne Seismograph, etc. Same, 1888, vol. xii, pp. 33-48.

\* Same, 1881, vol. fii, p. 147.

$E'$  be the force of the compensating spring and let  $h'$  be the length of the arm measured from the knife-edge. When the pendulum is displaced thru an angle  $\theta$ , the moment of the forces of restitution becomes

$$-\frac{MM}{da} \frac{dEh}{dt} (\theta) = -E'h'\theta \quad (128)$$

and the period of free vibration is

$$T_0 = 2\pi \sqrt{\frac{I}{Mgh'}} \quad (129)$$

If the pendulum points in the positive direction of  $y$ , it only records relative deflections around the axis (1). To find the equation of motion of these instruments when subjected to a disturbance, we proceed as in the former cases. For the last- described instrument, using the same notation as heretofore, we

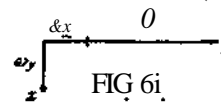

FIG 6i

equation of linear displacement of the CG,

$$M \frac{d^2x}{dt^2} = F_x - Mg + (E - \rho l \theta) - E' \quad (130)$$

The cosines of the angles between the fixed axes and axis (3) are (figure 61)

$$\cos(\alpha, 3) = -a, \quad \cos(y, 3) = -(a_x + 0) \quad \cos(z, 3) = 1 \quad (131)$$

and the general equation of angular acceleration around axis (1) becomes

$$\frac{d^2\theta}{dt^2} = \frac{1}{L} \left\{ \left( \frac{d^2\xi}{dt^2} + Z \frac{d^2\omega_y}{dt^2} - (Y+l) \frac{d^2\omega_y}{dt^2} \right) \omega_y + \left( \frac{d^2\eta}{dt^2} + X \frac{d^2\omega_x}{dt^2} - Z \frac{d^2\omega_x}{dt^2} - \frac{f_y}{M} \right) (\omega_x + \theta) - \left( \frac{d^2\xi}{dt^2} + (Y+l) \frac{d^2\omega_x}{dt^2} - X \frac{d^2\omega_y}{dt^2} \right) \right\} - \frac{(\rho l^2 - E'h')\theta}{[I]} - \frac{I_1}{[I]} \frac{d^2\omega_1}{dt^2} \quad (132)$$

The weight  $Mg$  has been eliminated through equation (125). If we make the  $CG_0$  the origin of coördinates, omit the negligible terms, and add terms for viscous damping and solid friction, the equation becomes

$$\frac{d^2c}{dt^2} + 2\kappa \frac{dc}{dt} + n^2c - \frac{n^2}{L} \frac{d^2\xi}{dt^2} = p' = 0 \quad (133)$$

If we had used the Ewing form of attaching the spring to a point below the bar we should have obtained a similar equation with  $E$  and  $h$  substituted for  $E'$  and  $h'$ . The indicator equation becomes, writing  $n^2$  for  $(2 \text{ Tr}/T)^2$ , or  $\{p_1^2 - E'h'\}/[I]$ ,

$$\frac{d^2c}{dt^2} + 2\kappa \frac{dc}{dt} + n^2c - \frac{n^2}{L} \frac{d^2\xi}{dt^2} = p' = 0 \quad (134)$$

where  $c$  is the recorded displacement of the marking point. These 2 equations are entirely similar to equations (25) and (26) for the horizontal pendulum, except that they do not contain a rotation. The physical explanation of this is that the position of equilibrium of the horizontal pendulum *relative to the support* is altered by the rotation  $\alpha$ , but that of the vertical motion pendulum is practically unaffected by a small rotation about any axis. If we place our origin at the  $CG_0$ , the only term in the general equation (132), containing the angular acceleration about (1), is  $(/[I])c^2/dt^2$ , which corresponds to the term we considered on page 158 for the horizontal pendulum. The factor  $/[I]$  will in general be small; for a beam carrying a brass sphere 10 cm. in diameter, at a distance of 40 cm. from the axis of rotation, it would not be as much as  $\frac{1}{5}$  and since  $cPw^2/dt^2$  is, in general, much less than  $d^2\theta/dt^2$ , the motion of these instruments is only affected to an entirely negligible extent by a rotation around the  $CG_0$ .

The form of instrument in most general use for recording vertical motion is that developed by Professor Vicentini of Padua,<sup>1</sup> though the principle seems to have been used in Comrie, Scotland, in 1841.<sup>2</sup> It consists of a heavy mass supported by an elastic rod so that it vibrates in a vertical plane, and records by means of multiplying levers on smoked paper. Usually there is no damping. The complete theory of this instrument is that of a weighted elastic rod, and is very complicated. It has several proper periods of vibration, and it would be set in vertical motion by a horizontal displacement in the direction in which it points. We can, however, develop an approximate theory which

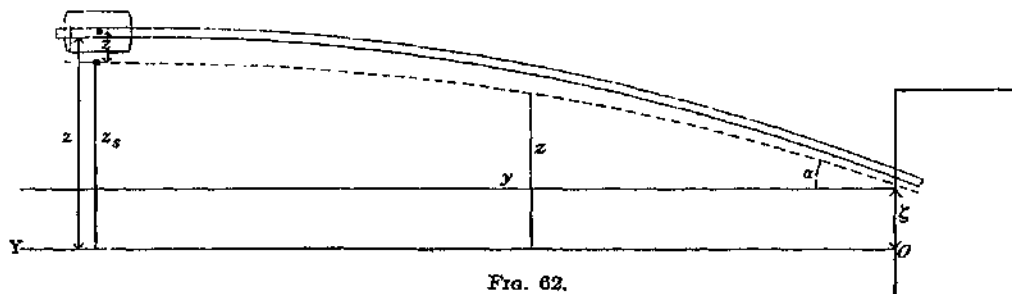

Fra. 62.

is quite simple. Let the instrument point in the positive direction of  $y$  and let  $z$  be positive upwards; see figure 62. Take the origin  $O$ , at a distance  $K$  below the point where the rod is supported. Later,  $\xi$  will be considered the vertical displacement of the support. Let  $l$  be the length of the rod,  $I$  the so-called moment of inertia of its cross-section, which we consider constant;  $E$  Young's modulus for the material of the rod,  $M$  the mass at its end, and  $M'$  an arbitrary mass. If we consider the bar but slightly bent, its curvature will be represented by  $d^2z/dy^2$ ; and we have from the general theory of a loaded cantilever, neglecting the weight of the rod,

$$EJcPz/dy^2 = -M'g(I - y) \quad (135)$$

Integrate this equation twice, and determine the constants of integration by the conditions that  $dz/dy = a$ , and  $z = \xi$ , when  $y = 0$ ; we get the equation

$$6EJ(z - \xi - ay) = -M'g(3I - 2fy) \quad (136)$$

where  $z$  refers to the point on the bar whose abscissa is  $y$ . For the  $CG$  of  $M'$ ,  $y = l$ , and letting  $z$  now represent the ordinate of this point, we get

$$6EJ(z - \xi - \alpha Z) = 2M'g\alpha \quad (137)$$

which gives us the ordinate of the  $CG$  when it is at rest, the mass being supported by the slightly bent rod.

To determine the acceleration when the weight is not at rest, we may replace  $M'$  by  $M + Mj$ ; and by d'Alembert's principle, equation (137) will still hold when we replace  $M'g$  by the force  $[M]d^2z/dt^2$ , where  $d^2z/dt^2$  is the acceleration of the  $CG$  and where  $[M] = M + (7' + n_2^2 / \dots) / l^2$  is the effective mass of  $M$  and the multiplying levers; this is analogous to the value of  $[I]$  determined on page 155 and can be found in the same way by the consideration of the reactions of the multiplying levers. On making these substitutions we get for the equation of the moving  $CG$  in absolute coördinates

$$6EJ(z - l - \alpha l) = -2Mgf - 2[M]l \frac{d^2z}{dt^2} \quad (137a)$$

<sup>1</sup> Microsismographo per la componente verticali, G. Vicentini e G. Faefaer. Boll. Soc. Sismologica Italiana, 1899-1900, vol. V, pp. 33-58.  
<sup>2</sup> British Assoc. Report, 1842, p. 64.

Writing  $z_s$  for the ordinate of the  $CG_0$  when at rest and the mass at the end of the rod is  $M$ , we get from (137)

$$6 EJ(z_s - \xi - cd) = -2 Mgf$$

The last two equations give by subtraction

$$\frac{d^2 z'}{dt^2} + 2\kappa \frac{dz'}{dt} + n^2 z' = -\frac{[M]l}{3EJ} \frac{d^2 \xi}{dt^2} \quad (138)$$

$z$  is the absolute ordinate of the  $CG$ ,  $z_s$  of the  $CG_0$ ; and  $z_s - K$  is the ordinate of the  $CG_0$  relative to the support. If the support vibrates under the action of earthquake waves,  $K$  will vary. In order to express the displacement in terms of the motion of the  $CG$  relative to the  $CG_0$  we must move our origin to  $z_s$ ,  $l$ , and call the displacement of the  $CG$  from this point  $z'$ ; that is, we substitute  $z - z_s = z'$ , and since  $z_s - K$  is constant when  $\xi$  is varying under the vertical movement of the support,  $d^2 z_s / dt^2 = d^2 Z / dt^2$ ; we get

$$z' = -\frac{[M]l}{3EJ} \left( \frac{d^2 z'}{dt^2} + \frac{d^2 \xi}{dt^2} \right) \quad (139)$$

Introducing damping and frictional terms, and putting  $3 EJ/[M]l^2 = (2\pi/7^7)^2 = n^2$ , this may be written

$$\frac{d^2 z'}{dt^2} + 2\kappa \frac{dz'}{dt} + n^2 z' + \frac{d^2 \xi}{dt^2} = p_0 = 0 \quad (140)$$

For the equation of the marking point we multiply by  $m^{-1} = \rho n^2 l^2$ ; and since  $c$ , the displacement of the marking point equals  $mz'$ , we get

$$\frac{d^2 c}{dt^2} + 2\kappa \frac{dc}{dt} + n^2 c - \bar{m} \frac{d^2 \xi}{dt^2} = p' = 0 \quad (141)$$

which is entirely similar to the equations of the other forms of vertical motion instruments.

As we have only considered linear displacements, the position of the origin of coördinates is unimportant; but if a rotation occurs, it must be considered. A rotation around the  $CG_0$  as origin would evidently have no effect, if we neglect the moment of inertia of the mass about its  $CG$ , as we have done. But an angular acceleration  $d^2 a > J dt^2$  around an axis through  $O$  at right angles to the paper would make  $z_s - K - c \cos \theta$  instead of  $z_s - K - c$  constant during the motion and would therefore add a term  $l d^2 a / dt^2$  to (140) and  $\bar{m} l d c \cos \theta / dt^2$  to (141). These terms in general would probably be unimportant.

We see thus that the approximate equations of all forms of seismographs referred to the  $CG_0$  are of the same general form; except that no rotation is present in the equations of the vertical motion instruments. The formulas (79a) and (81) are applicable to them all to determine their magnifying powers.

#### SEPARATION OF LINEAR DISPLACEMENTS AND TILTS.

A rigid body can be moved from one position in a plane to any other by means of a linear displacement and a rotation; altho the direction of the axis of the rotation and the amount of the rotation are determined by the two positions of the body, the distance of the axis is not; we can choose this distance arbitrarily and then determine the linear displacement to correspond; and the total displacement of a point of the body will be the displacement due to the rotation around the axis plus the linear displacement of the axis; as the rotation is independent of the distance of the axis, the nearer the latter is to the body, the greater will be the displacement due to the displacement of the axis and the less will be that due to rotation; and there is one distance of the axis for which all the displacement may be expressed as a rotation. We see therefore the origin of the difficulty

in separating displacements and rotations; for their relative effects in producing movements of the seismograph depend on the arbitrary choice of the axis for the rotation. This appears in equation (16), where the values of the various coefficients depend on the choice of the origin of coördinates, about which the rotations are supposed to take place.

If we could get rid of the effects of linear displacements, we could determine the rotations. This was first done by Professor Milne<sup>1</sup> who supported a beam by knife-edges at its center of gravity; and later by Dr. Schliiter.<sup>2</sup> These instruments failed to show any tilts at the times of the earthquakes, which therefore must be extremely small.

A second method of determining tilts has been proposed by Professor Wiechert.<sup>3</sup> Let two horizontal pendulums with equal values of  $K$ ,  $ril/L$  and  $gi/L$  be installed, one vertically over the other; and let the origin of coördinates be chosen at the  $CGQ$  of the lower pendulum; its equation will be

$$\frac{d^2 a_1}{dt^2} + 2K \frac{da_1}{dt} - \frac{\bar{n}l}{L} \frac{d^2 \xi}{dt^2} + \frac{\bar{n}l\omega_0}{L} \xi = 0 \quad (25)$$

the equation of the upper pendulum will be

$$\frac{d^2 a_1}{dt^2} + 2K \frac{da_1}{dt} - \frac{\bar{n}l}{L} \frac{d^2 \xi}{dt^2} - \frac{\bar{n}lZ'}{L} \frac{d^2 \xi}{dt^2} + \frac{\bar{n}lZ'}{L} \xi + \frac{\bar{n}lZ'}{L} \xi = 0 \quad (142)$$

it contains an extra term  $-\frac{\bar{n}lZ'}{L} \frac{d^2 \xi}{dt^2}$  where  $Z' = Z - il$  is, in this case, the distance between the centers of gravity of the 2 pendulums; the origin of this term will appear on referring to equation (16). On taking the difference of these two equations we get

$$\frac{d^2 (a_2 - a_1)}{dt^2} + 2K \frac{d(a_2 - a_1)}{dt} - \frac{\bar{n}l}{L} \frac{d^2 \xi}{dt^2} + \frac{\bar{n}lZ'}{L} \xi = 0 \quad (143)$$

which gives us a relation between the record and the angular acceleration of the earth about the axis of  $y$  without containing the linear displacement. If we work out the value of  $co_y$  and substitute it in equation (25) we can then find the linear acceleration. Prince Galitzin has shown a very elegant manner of carrying out this process by the use of his method of electromagnetic recording thru a galvanometer.<sup>4</sup> Professor Wiechert's method presupposes that the supports of the 2 pendulums move as tho they were parts of a rigid body, and therefore that the motions can be represented as the same rotation about the same axis. This would certainly not be the case if the upper instrument were mounted in a high building, for then the vibrations of the building would interfere; and it may be questioned whether the condition would hold for two points at different distances below the surface of the earth. But if two pendulums are mounted, one above the other on the same support, as Prince Galitzin arranged them in his experiments, these objections disappear.

A similar method can be applied to vertical motion instruments; let us suppose that two similar instruments are mounted close together with their axes of rotation in the same straight line, but with their beams pointing in opposite directions; it is evident that any vertical displacement would affect them alike, but a rotation around their common axis of rotation would cause movements in opposite directions. The equations of the two

<sup>1</sup> British Assoc. Reports, 1R92.

<sup>2</sup> Schwingungsart und Weg der Erdoberfläche. Gerland's Beiträge zur Geophysik, 1903, vol. V, pp. 314-359, 401-465.

<sup>3</sup> Principien für die Beurteilung der Wirksamkeit von Seismographen. Verhand. 1<sup>8to</sup> Intern. Seismol. Konferenz. Geol. und Bergbau zur Geophysik, Ergänzungsband I, pp. 264-280.

\* Ueber die Methode zur Beobachtung von Neigungswellen. Acad. Imp. des Sciences St. Petersburg. C. R. Com. Perm. Sfaraique, 1905, T. II, Liv. II, pp. 1-144.

instruments would be, on putting the origin of coördinates at the axis of rotation (see equations (132) and (134)),

$$\left. \begin{aligned} & \frac{d^2 c_1}{dt^2} - 2\kappa \frac{dc_1}{dt} + n^2 c_1 - \frac{nl}{L} \frac{d^2 \theta}{dt^2} + \frac{nl}{L} \frac{d^2 \omega}{dt^2} + p_2' = 0 \\ & \frac{d^2 c_2}{dt^2} + 2\kappa \frac{dc_2}{dt} + n^2 c_2 - \frac{nl}{L} \frac{d^2 \theta}{dt^2} + \frac{nl}{L} \frac{d^2 \omega}{dt^2} + p_2' = 0 \end{aligned} \right\} \quad (144)$$

on adding these two equations, the tilt disappears; and on subtracting one from the other, the vertical linear displacement disappears. The two instruments record the displacement and rotation of the same point, and therefore the separation of these two involves no supposition as to the motions of points at some distance apart.

Prince Galitzin has described another method of measuring comparatively rapid tilts. He has shown that a bar hung by wires of equal length, attached to its ends, the wires themselves being fastened to the support at different heights, so that the bar hangs in an inclined position, will be rotated around a vertical plane by a tilt at right angles to the plane of the wires, and this rotation will not be affected by the swinging of the bar as a pendulum. This is a modification of the bifilar pendulum, designed by Mr. Horace Darwin for the study of slow earth-tilts.<sup>1</sup>

<sup>1</sup> See C. Davison, Bifilar Pendulum for Measuring Earth-Tilts. Nature, 1894, vol. L, pp. 246-249.



DEFINITIONS.

$\xi, r_j, \xi$ , linear displacements of the ground.	$M$ , mass of the pendulum.
$\omega$ , rotation of the ground.	$I$ , distance of <i>CG</i> from the axis of rotation.
$P$ , period of linear displacements of the ground.	$L = [I \sim \sqrt{MI}]$ , distance of center of oscillation from axis of rotation.
$Q$ , period of rotations of the ground.	$i$ , inclination of axis of rotation to the vertical.
$p = 2\pi r/P$	$U = L/i$ , length of simple mathematical pendulum having the same period.
$T$ , period of the pendulum with damping.	$K$ , coefficient of viscous damping.
$T_o$ , period of the pendulum without damping.	$1/K$ , relaxation time, that is, the time required for the amplitude to diminish in the proportion 1: $1/e$ .
$T_v$ , period of the pendulum without damping when swung vertically.	$c$ , damping ratio.
$CG$ , center of gravity of the pendulum at any time.	$A$ , logarithmic decrement.
$CG_o$ , center of gravity of the pendulum when at rest.	$r$ , frictional displacement of medial line.
$CG_{,,}$ , center of gravity of the pendulum supposed rigidly connected with the support and moving with it.	$a$ , amplitude of the recording point.
$J_i$ , moment of inertia of the pendulum about <i>CG</i> .	$A$ , range of the recording point.
$J_{(1)}$ , moment of inertia of the pendulum about axis of rotation.	$V$ , magnifying power for rapid linear harmonic displacements.
$[/]$ , complete moment of inertia about axis of rotation, including the magnifying levers.	$W$ , magnifying power for linear harmonic displacements of any period.
	$U$ , magnifying power for harmonic rotations of any period.

USEFUL FORMULAE.

$$i = T_v > T_0^* \quad (34)$$

$$\frac{g^i}{L} = \frac{g}{V} = \left(\frac{2\pi}{T_0}\right)^2 \quad (38)$$

$$T_0 = \frac{T}{\sqrt{1 + (\kappa T/2\pi)^2}} \quad (38a)$$

$$T_0 = T \sqrt{1 - (KT/2 - n)^2} \text{ when } \kappa \text{ is small} \quad (39)$$

$$\left(\frac{\kappa T_0}{2\pi}\right)^2 = \left(\frac{\kappa T}{2\pi}\right)^2 / \left\{1 + \left(\frac{\kappa T}{2\pi}\right)^2\right\}$$

$$\left(\frac{\kappa T_0}{2\pi}\right)^2 = \frac{\log^2 \epsilon}{7y} = \frac{\log^2 \epsilon}{1.862 + \log^2 \epsilon} \quad (44)$$

$\frac{KT}{2\pi} = \frac{\Delta}{\pi} = \frac{0.733}{n} \log \epsilon^n$

$$\frac{1}{\kappa} = \frac{T}{2\Delta} \text{ from} \quad (44)$$

$$\epsilon^n = \frac{A_1 - A_{n+1}}{A_{n+1} - A_{2n+1}} \quad (54)$$

$$2r = \frac{A_2^2 - A_1 A_3}{A_1 - A_3} \quad (52)$$

$$2r = \frac{\epsilon - 1}{\epsilon + 1} \frac{A_{n+1}^2 - A_1 A_{2n+1}}{(A_1 - A_{n+1}) - W_{n+1} - A_{n+1}} \quad (57)$$

$$\kappa = \frac{4.605}{nT} \log \frac{A_1 - A_{n+1}}{A_{n+1} - A_{2n+1}} \quad (56)$$

$$W = \frac{V}{JA \frac{\log^2 \epsilon}{1.862 + \log^2 \epsilon} \left(\frac{2y}{T_0}\right) + \left\{\left(\frac{PV}{T_0}\right) - iT\right\}} \quad (79a)$$

$$W = \sqrt{4 \left(\frac{\kappa T_0}{2\pi}\right)^2 \left(\frac{P}{T_0}\right) + \left\{\left(\frac{P}{T_0}\right) - 1\right\}^2} + 4 \left(\frac{\kappa T_0}{2\pi}\right) \left(\frac{P}{T_0}\right) \left(\frac{4r}{\pi a}\right) \left(\frac{P}{T_0}\right) + \left(\frac{4r}{\pi a}\right)^2 \left(\frac{P}{T_0}\right)^2 \quad (81)$$

$$U = \frac{\bar{n}}{i} \frac{Y}{\sqrt{4 \frac{\log^2 \epsilon}{1.862 + \log^2 \epsilon} \left(\frac{Q}{T_0}\right)^2 + \left\{\left(\frac{Q}{T_0}\right) - 1\right\}^2}} \quad (91)$$

$$F = \frac{\bar{n}}{i} = \frac{\bar{n}f}{L} = a/L \quad (29) \text{ and } (33)$$

where  $a_a$  is the displacement of the pointer corresponding to an angular displacement  $\delta$  of the pendulum.

RECORD OF AFTER-SHOCKS.

Record of after-shocks — Continued.

Day.	Beginning of shock.	Duration.	Intensity.	Locality.	Remarks.
Apr. 30, p.m.	h. m. s.	secs.			
	1 05.....	2.....	.....	Mile Rocks.....	Vertical. Strongest at end.
	10 50.....	.....	.....	Scott's Valley.....	Barely perceptible, F. L.
	10 58.....	.....	.....	Cape Mendocino.....	Southwest. Vertical. Direction south, very light.
	11 10.....	.....	.....	Eureka.....	Slight.
May 1, a. m.	6 05.....	2.....	.....	Mile Rocks.....	Slight.
	9 21.....	.....	.....	Cloverdale.....	
May 1, p.m.	9 19.....	15.....	.....	Healdsburg.....	Very smart shock, perceptible roaring, oscillatory.
	9 30.....	.....	.....	Guerneville.....	Articles thrown from north to south. Cracked much plaster.
	9 45.....	I 1-4.....	.....	Mile Rocks.....	Slight.
	9 57 55.....	.....	.....	Berkeley.....	A. O. L.
	9 58.....	.....	.....	do.....	Faculty Club, G. K. G.
	9 58 24.....	12.....	III	do.....	East-west. Several max. Had watch out in 3 s., slight shaking 30 s. more, S. A.
	.....	.....	.....	Napa.....	No time given. Three light shocks during day, W. H. M.
	.....	.....	.....	Peachland.....	No time given.
May 2, a. m.	I 12 36.....	I.....	.....	Napa.....	Sharp, W. H. M.
	4 05.....	.....	.....	Los Gatos.....	I. H. S.
	6 51 30.....	.....	.....	San Francisco.....	Very light, A. G. McA.
	6 56 20.....	.....	II	Oakland.....	Chabot Observatory.
	8 50.....	.....	.....	San Francisco.....	Very light, A. G. McA.
May 2, p.m.	4 51 13.....	.....	11	Mt. Hamilton.....	C. D. P.
	4 53.....	.....	.....	Santa Cruz.....	Lively shake.
	9 22.....	.....	.....	Calistoga.....	
	9 58.....	.....	.....	S. F. Peninsula.....	
	10 53.....	.....	.....	Scott's Valley.....	Two vibrations apparently from SE., F. L.
	.....	.....	.....	Laurel.....	No time given.
May 3, a.m.	1-3.....	.....	.....	Glenwood.....	12 quakes, each preceded by sounds.
	5 56.....	5.....	.....	Scott's Valley.....	Reported as 6 a.m. in Santa Cruz. Strong vibrations east-west. Sleepers generally awakened, F. L.
	G.....	I.....	.....	Santa Cruz.....	
	6.....	.....	.....	Point Pinos.....	Short.
	6.....	.....	.....	Los Gatos.....	Vertical, I. H. S.
	6.....	.....	.....	San Francisco.....	Very light, A. G. McA.
	6 20.....	.....	.....	Oakland.....	Chabot Observatory.
	9 41 22.....	.....	.....	San Francisco.....	Very light, A. G. McA.
May 3, p.m.	4 17.....	.....	.....	Los Gatos.....	I. H. S.
May 4, a.m.	j 12 05.....	.....	.....	Scott's Valley.....	" Wakened me," F. L.
	I 5.....	.....	.....	Point Pinos.....	
	5 25.....	5.....	II	Mt. Hamilton.....	Two distinct principal shocks, 0.5 s. apart, 3 s. after beginning. North to south. No sound. No vertical motion, J. D. M.
	5 28.....	.....	.....	Los Gatos.....	I. H. S.
	5 32.....	.....	.....	San Francisco.....	Very light, A. G. McA.
	(5.....	12.....	.....	Scott's Valley.....	Two people at least were? awakened. Three shocks almost continuous, not severe.
	H 30.....	5.....	.....	do.....	Very slight trembling for perhaps 5 s., F. L.
	10 29 30.....	.....	.....	Sun Francisco.....	Sharp jar, A. G. McA.
	10 40.....	.....	.....	Los Gatos.....	I. H. S.
	.....	.....	.....	Campbell.....	No time given.

## Record of after-shocks—Continued.

Day.	Beginning of shock.	Duration.	Intensity.	Locality.	Remarks.	
May 5, a. m.	h. in. s.	secs.				
	10 15.....	3.....	.....	Mile Rocks.....	Moderate.	
	10 28.....	.....	.....	Oakland.....	Chabot Observatory.	
	10 29 30.....	.....	.....	San Francisco.....	A. G. McA.	
	10 29 43.....	.....	.....	Berkeley.....	Northwest-southeast. Single displacement to northwest, with return to southeast, B. L. N.	
	10 29 45 + 2	.....	II	do.....	J. N. LeC.	
	10 30.....	.....	IV	S. F. Peninsula...		
	10 30.....	.....	.....	Napa.....	W. H. M.	
	10 30.....	.....	.....	Oakland.....	Alameda Pier.	
	10 30 05...	1.....	.....	Mt. Hamilton.....	W. W. O.	
May 5, p. m.	11 45.....	1.....	.....	Mile Rocks.....	Slight.	
May 6, a. m.	.....	.....	.....	Campbell.....		
	.....	.....	.....	San Francisco.....	Several tremors during early morning.	
	3 05.....	.....	.....	Los Gatos.....	Rotary motion north-south. Vertical, I. H. S.	
	7 29.....	.....	.....	San Francisco.....	Light, A. G. McA.	
	8 40.....	1.....	.....	Mile Rocks.....	Slight.	
	8 59 20.....	.....	.....	San Francisco.....	Strong. Last one double wave. Felt like a push. Then more waves, A. G. McA.	
	May 6, p. m.	8.....	.....	.....	Bartlett Springs..	
	8 10.....	10.....	VII	Upper Lake.....	Very violent, almost due east, sudden.	
	8 12 34....	25.....	III-IV	Ukiah.....	Direction west-east, increasing intensity. No max. No noise. Watch compared immediately; times probably not in error more than 2 s., S. D. T.	
	8 17.....	.....	.....	do.....		
8 32.....	.....	.....	do.....			
9 +.....	5.....	VII	Upper Lake.....	Very violent, many clocks stopt, I. H. S.		
9 +.....	.....	.....	Los Gatos.....			
9 45.....	1.....	.....	Mile Rocks.....			
11 15.....	1.....	.....	do.....			
11 25.....	.....	.....	Los Gatos.....	Rotary, I. H. S.		
.....	.....	.....	Blocksburg.....	No time given.		
May 7, a. m.	.....	.....	.....	San Francisco.....	Several tremors during night. About 3 a. in.	
3.....	.....	.....	Point Pinos.....			
3 20.....	1.....	.....	Mile Rocks.....			
3 45.....	.....	.....	do.....			
5 07.....	.....	.....	San Francisco.....	Very light, several light tremors during night and early morning, A. G. McA.		
May 7, p. m.	4 10.....	.....	.....	Los Gatos.....	Rotary, I. H. S.	
4 17 10....	.....	.....	San Francisco.....	Sharp jar, A. G. McA.		
4 30.....	.....	.....	Bartlett Springs..			
May 8, a. m.	4 30.....	.....	.....	Los Gatos.....	I. H. S.	
10 16.....	.....	.....	Yerba Buena.....	Light.		
May 8, p. m.	12 12.....	.....	.....	San Francisco.....	Light, A. G. McA.	
11 40.....	.....	.....	Campbell.....			
11 40.....	.....	.....	Los Gatos.....	North-south, I. H. S.		
11 40.....	.....	.....	Point Pinos.....	Indefinite as to a. m. or p. m.		
11 42.....	.....	.....	San Francisco.....	Sharp jar, A. G. McA.		
11 42 02....	10.....	II-III	Palo Alto.....	No max. No noise. Also felt by Prof. L. M. Hoskins, but no time taken. Watch compared with standard clock at Ukiah at 10 p. m., May 8, and at 11 a. in., May 9. S. D. Townley.		

Record of after-shocks — Continued.

Day.	Beginning of shock.	Duration.	Intensity.	Locality.	Remarks.
	h. m. s.	secs.			
May 8, p.m.	.....	.....	.....	Salinas .....	No time given.
May 9, a.m.	.5 20.....	.....	.....	San Francisco .....	Light, A. G. McA.
	5 44 13....	.....	.....	Palo Alto.....	Just one jolt. Not felt by Prof. Hoskins; absolutely certain it was quake, S. D. T.
May 9, p.m.	2 .....	.....	.....	Saratoga .....	About 2 p. m. Like explosion under foot.
	7 25.....	.....	.....	Eureka.....	South-north. Several seconds. Shook windows.
	9 30.....	3.....	.....	Ferndale .....	J. A. S.
	10 30.....	.....	.....	Salinas.....	
	.....	.....	.....	Los Gatos.....	Two light shnc-ks, I. H. S,
May 10, a.m.	12 15.....	.....	.....	San Francisco .....	Light, A. G. McA.
	6 47.....	.....	.....	Blocksburg .....	
	6 55.....	3.....	.....	Ferndale.....	J. A. S.
	6 59.....	4.....	.....	Eureka.....	Slight sudden jolt. South to north.
	10 45.....	.....	.....	Blocksburg.....	One light shock.
	.....	.....	.....	Los Gatos.....	One light shock, I. E. S.
	.....	.....	.....	Laurel.....	No time given.
	.....	.....	.....	Montague.....	No time given.
May 11, p.m.	1 10.....	2.....	.....	Mile Rocks.....	Slight.
	1 27 46.....	.....	.....	Oakland.....	Chabot Observatory.
	1 27 50.....	25".....	.....	Bolinas.....	
	1 30.....	.....	.....	Napa.....	W. H. M.
	1 30.....	2.....	.....	Bonita Point.....	Nearly vertical. Prop. NW. No tremor, just a jar. 1 max., strongest at beginning. Rumbling coincident with shake. May have been blasting.
	1 30 49.....	3.....	.....	San Francisco.....	Heavy, A. G. McA.
	1 40.....	.....	.....	Salinas.....	
	1 40 4±10.....	.....	11 +	Berkeley.....	Residence 1820 Walnut St.
	1 45.....	.....	.....	Kentfield.....	
	.....	.....	.....	Los Gatos.....	One light shock. No time given, I. H. S.
	3 30.....	.....	.....	Napa.....	W. H. M.
May 12, a.m.	4 00.....	.....	.....	do.....	North-south.
May 13, p.m.	7 50.....	.....	.....	do.....	North-south.
May 14, p.m.	5 19.....	.....	V	S. F. Peninsula...	Caused ground in tremble distinctly, and brought down broken plaster.
	5 21.....	.....	.....	San Francisco.....	Sharp jar, A. G. McA.
	9.....	.....	.....	Campbell.....	
	9.....	.....	.....	Los Gatos.....	North-south, I. II. S.
	9 03.....	.....	.....	San Francisco.....	Light, A. G. McA.
May 15, a.m.	12 30.....	.....	.....	Berkeley.....	G. K. G.
	1 10.....	.....	.....	do.....	G. K. G.
	2 20.....	.....	.....	Point Pinos.....	Vertical.
	9 20.....	.....	.....	Mile Rocks.....	Moderate.
	11 53.....	.....	.....	Los Gatos.....	I. H. S.
	11 56 47....	5.....	II-III	Mt. Hamilton.....	Ending with jolt, Mrs. R. G. A.
May 15, p.m.	4 20.....	.....	.....	Los Gatos.....	I. H. S.
	.....	.....	.....	Campbell.....	No time given.
May 16, a.m.	5 20.....	3.....	.....	Ferndale.....	I. J. A. S.
May 16, p.m.	11.....	.....	.....	Heber.....	
	11 30.....	.....	.....	Berkeley.....	G. K. G.
	.....	.....	.....	Salinas.....	No time given.

## Record of after-shocks—Continued.

Day.	Beginning of shock.	Duration.	Intensity.	Locality.	Remarks.
May 17, a.m.	h. m. s. During night 12 18 .....	secs. ..... .....	VI	Imperial .....	Two slight shocks.
	12 30 .....	.....		S. F. Peninsula...	One of the severest since the first shock, woke all sleeper's, swayed houses, set dogs barking.
	12 35 .....	.....		Berkeley .....	G. K. G.
	11 05 45 .....	.....		Los Gatos .....	I. H. S.
May 17, p.m.	3 40 .....	.....	.....	San Francisco .....	Light, A. G. McA.
	8 15 .....	35 .....	.....	Ferndale .....	Two more before 6 a.m., J. A. S.
	8 17 .....	.....	.....	Mile Rocks .....	Vertical. Strongest in middle.
	8 17 .....	.....	V	Oakland .....	Alameda Pier.
	8 20 .....	.....	.....	Los Gatos .....	Short, but with considerable vertical motion, I. H. S.
	8 20 .....	2 .....	.....	Salinas .....	Nearly vertical. Direction N., no tremor, just a jar, 1 max., strongest at beginning. No sound, may have been blasting.
	8 20 .....	.....	.....	Bonita Point .....	Horizontal. Two max. alike, sound like water in pipe with air in it.
	8 21 .....	20 .....	VI	Point Pinos .....	Chabot Observatory.
	8 21 .....	.....	.....	Oakland .....	About the heaviest since first shock, causing people to rush out-of-doors.
	8 21 .....	.....	.....	S. F. Peninsula...	W. H. M.
	8 21 .....	.....	.....	Napa .....	Violent.
	8 21 .....	.....	.....	Gonzales .....	Chandelier swung with period of 1.25 s. Shock NW.-SE. at Vernon St., R. T. C.
	8 21 17 .....	12 .....	IV-V	Campbell .....	Vertical slightly, 2 max. 5 s. and 10 s. after beginning, mean of two observers, W. W. C.
	8 21 22 .....	14 .....	IV	Oakland .....	East-west, A. O. L.
	8 21 34 .....	8 .....	.....	Mt. Hamilton .....	S. A.
	8 21 40 .....	8 .....	III	Berkeley .....	Light.
	8 22 .....	.....	.....	Bolinas .....	Faculty Club, G. K. G.
8 22 25 .....	.....	.....	Yerba Buena .....	Moderate rolling motion, A. G. McA.	
8 24 30 .....	.....	.....	Berkeley .....	Very slight. No time given.	
8 24 33 .....	.....	.....	San Francisco .....	Southeast-northwest. Rumbling before shake and continuing 2 s. after.	
8 30 .....	2 .....	.....	do .....	No time given.	
May 18, a.m.	.....	.....	.....	Southampton Shoal	No time given.
	.....	.....	.....	Livermore .....	No time given.
	12 22 .....	.....	.....	San Luis Qbispo .....	
	1 45 .....	.....	.....	Berkeley .....	G. K. G.
May 18, p.m.	5 29 .....	.....	.....	do .....	G. K. G.
	5 29 .....	.....	.....	Los Gatos .....	I. H. S.
	7 56 .....	.....	.....	San Francisco .....	Light, A. G. McA.
	8 30 .....	2 .....	.....	do .....	
May 19, a.m.	8 37 .....	3 .....	II-III	Los Gatos .....	I. H. S.
	8 37 .....	.....	.....	Ope Mondocino...	Southwest. Vertical. Direction S. Very light.
	8 37 .....	.....	.....	Ukiah .....	No max. No sound. Watch compared immediately and clock correction determined within an hour, S. D. T.
	8 37 .....	.....	.....	do .....	
	8 37 .....	.....	.....	Ferndale .....	J. A. S.
	8 37 .....	.....	.....	Fort Bragg .....	
May 19, a.m.	8 37 .....	.....	.....	Blocksburg .....	
	8 37 .....	.....	.....	Los Gatos .....	I. H. S.
	8 37 .....	.....	.....	do .....	Slight.
May 19, a.m.	8 37 .....	.....	.....	Campbell .....	
	8 37 .....	.....	.....	Los Gatos .....	East-west. Vertical, I. H. S.

Record of after-shocks — Continued.

Day.	Beginning of shock.	Duration.	Intensity.	Locality.	Remarks.
May 19, a.m.	h. m. s.	secs.	II-III	Mt. Hamilton..... do..... Ferndale..... Los Gatos.....	East-west, W. W. C. Very slight shock, J. A. S. I. H. S.
	2 32 10....	.....			
	3 30.....	.....			
	4 47.....	.....			
May 19, p.m.	11 30.....	.....	.....	do..... Fort Bragg..... Blinckeburg.....	No time given.
	2 30.....	.....	.....		
	11 56.....	.....	.....		
May 20, a.m.	2 35.....	.....	.....	Carson City.....	Light. West-east, C. W. F.
May 20, p.m.	9 05.....	.....	.....	Fort Bragg.....	I. H. S.
	11 00.....	.....	.....	Los Gatos.....	
May 21, a.m.	5 30.....	3.....	.....	Mile Rocks.....	Moderate.
May 21, p.m.	2 00.....	.....	III	Los Gatos..... S. F. Peninsula..... do.....	I. H. S.
	4 50.....	.....			
	12 00.....	.....			
May 22, a.m.	.....	.....	.....	Los Gatos..... Ferndale.....	No time given, I. H. S. Before daylight. Very slight, J. A. S.
	.....	.....	.....		
May 22, p.m.	12 30.....	.....	.....	Bartlett Springs..	"The tremor might have been due to thunder."
May 23, a.m.	5 30.....	.....	.....	Los Gatos.....	I. H. S.
May 24, a.m.	1 30.....	.....	.....	do.....	I. H. S.
May 24, p.m.	1 28.....	.....	.....	do.....	I. H. S. <b>r. H. S.</b> Nearly vertical. Direction NE. No tremor, just a jar. 1 max. strongest at begin- ning. Sound like clap of thunder 2 s. before. May have been blasting.
	S 45.....	.....	.....	do.....	
	11 17.....	2.....	.....	Bonita Point.....	
May 25, a.m.	12 58.....	45-50	.....	Berkeley.....	At Faculty Club. First irregular, then rhythmic and slow, then more rapid. During rhythmic part was able to recognize a distinctly east-west direction, and thought this changed later to north-south, but not quite sure, G. K. G.
May 25, p.m.	10 21.....	&.....	.....	do.....	Began with confused irregular motion, but middle and final portions definitely rhythmic I tried without use of watch to estimate period of rhythm, and think it was between 2 and 5 beats of the second, G. K. G.
May 27, it. in.	Early.....	.....	.....	Lo < GuU*..... Santa Cruz.....	I. H. S. Slight shock.
May 28, a in.	1 00.....	.....	.....	Los Gatos.....	I. H. S. I. H. S. S. H. S.
	1 4.....	.....	.....	<.....	
	4 Of.....	.....	.....	do.....	
May 28, p in.	10 47.....	.....	.....	Santa Cruz.....	
May 30, p in.	11 27 20"	.....	.....	Saint Francis-ro.....	Light. A. G. McA.
May 31, a HI	Early.....	.....	.....	Los Gatos.....	I. H. S.

## Record of after-shocks — Continued.

Day.	Beginning of shock.	Duration.	Intensity.	Locality.	Remarks.
May 31, a.m.	h. m. s.	<b>secs.</b>			
	5 45.....	.....	.....	Napa .....	W. H.M.
	5 49 54....	.....	.....	Berkeley.....	R. T. C. in bed. Short and sharp.
	5 50.....	.....	.....	San Francisco___	Light, A. G. McA.
June 3, a.m.	8 25.....	.....	.....	Los Gatos .....	I. H. S.
	9 17.....	.....	.....	do.....	
June 4, p.m.	9 40.....	.....	.....	Ferndale .....	Very slight, J. A. S.
	11 40.....	2.....	.....	Mile Rocks .....	
	11 50.....	.....	.....	Los Gatos .....	Rotary, I. H. S.
	11 50.....	.....	.....	Campbell.....	Sharp.
	11 50 50....	3.....	III	Oakland.....	Chabot Observatory. South-west to northeast,
	11 51.....	.....	.....	Mills College.....	
	11 51 07....	60 +...	IV-V	Berkeley.....	Ewing seismograph.
	11 51 45....	.....	.....	do.....	A. O. L.
	11 52.....	.....	.....	San Francisco___	A. G. McA.
	11 55.....	.....	.....	Napa .....	No time given.
June 5, a.m.	9 50.....	.....	.....	Los Gatos .....	I. H. S.
June 5, p.m.	11 55.....	.....	.....	Niles .....	
June 7, a.m.	12 21 39....	.....	.....	Berkeley.....	A. O. L.
	.....	.....	.....	Eureka.....	No time given.
	.....	.....	.....	Upper Mattole___	Heavy. No time given.
June 7, p.m.	4 10.....	.....	.....	Blocksburg .....	
	4 13.....	15.....	.....	Ferndale.....	Slight, J. A. S.
	4 15.....	.....	.....	Fort Bragg .....	
	4 15.....	26.....	.....	Eureka .....	South of west to east. Sudden, increasing, then dying. Shook buildings. Severest since April 18, A. H. B.
June 8, a.m.	5 15.....	.....	.....	Fort Ross .....	
	9.....	.....	.....	do.....	
June 8, p.m.	6 15.....	1.....	.....	Mile Rocks.....	Slight.
June 9, a.m.	11 35.....	.....	.....	Fort Ross.....	
	11 56.....	.....	.....	do.....	
June 9, p.m.	7 40.....	.....	.....	Mills College.....	A. G. McA.
	7 41.....	.....	.....	San Francisco....	
June 10, p.m.	.....	.....	.....	Eureka.....	No time given.
	4 00.....	.....	.....	Los Gatos.....	I. H. S.
	6 26.....	2.....	.....	Ferndale.....	Slight shock, J. A. S.
	9 41.....	.....	.....	San Francisco___	
June 11, a.m.	.....	.....	.....	Napa .....	No time given.
	4 30 Ship's time	10.....	.....	Coronel Bay, South America .....	S.S. Assuan. Sharp shock.
June 12, p.m.	2±.....	.....	.....	Los Gatos .....	
June 13, a.m.	11 50.....	.....	.....	Eureka.....	Very light shock.
	.....	.....	.....	Tequisquita Ranch	No time given.
	.....	.....	.....	Campbell.....	No time given.
	11 51.....	.....	.....	Ferndale.....	Very light, J. A. S.
June 14, a.m.	4 50.....	.....	.....	do.....	Very light, J. A. S.
June 14, p.m.	5 55.....	.....	.....	Los Gatos.....	



Record of after-shocks — Continued.

Day.	Beginning of shock.	Duration.	Intensity.	Locality.	Remarks.
June 14, p.m.	h. m. s. 5 56..... 11 35.....	secs. ..... .....	..... .....	Los Gatos..... do.....	
June 15, a.m.	3 40..... 6 11 50....	..... .....	..... .....	Fort Bragg..... Mt. Hamilton....	E. S.
June 15, p.m.	12 05..... 12 09..... 9 20..... 9 25..... 9 39 35....	..... ..... ..... <b>5</b> ..... .....	..... ..... ..... ..... .....	Los Gatos..... do..... Sonoma..... Mile Rocks..... Berkeley.....	Moderate. Omori seismograph, east-west. Component $79 \pm 10$ ; north-south component $76 \pm 10$ . Chabot. Observatory. From northeast.
	9 39 45....	<b>3</b> ....	III	Oakland.....	
	9 40..... 9 40 52....	..... .....	..... II	Sonoma..... Berkeley.....	East-west 2 shocks, 1 & apart, A. O. L. A. G. McA.
	9 41..... 9 41..... 9 41..... 9 41 52.... 9 42..... 9 45..... 9 51 39.... <b>10 30</b> <b>10 32 64!</b>	..... ..... ..... ..... ..... ..... ..... 2..... 12.....	..... ..... ..... ..... ..... ..... <b>I</b> ..... .....	San Francisco..... Los Gatos..... Mills College..... Berkeley..... Niles..... Livermore..... Berkeley..... Mile Rocks..... Berkeley.....	R. T. O. W. B. A. O. L. Slight. Omori seismograph, east-west component. Omori seismograph, north-south component. A. G. McA. No time given. No time given. Three shocks reported, W. H. M.
	10 35.....	17.....	.....	do.....	
	10 35.....	.....	.....	San Francisco..... Peachland..... Napa.....	
June 16, a.m.	9 15..... .....	..... .....	..... .....	Los Gatos..... Peachland.....	T. H. S. No time given.
June 16, p.m.	4 50..... 11 50.....	..... .....	..... .....	Ferndale..... do.....	Light, J. A. S. Light, J. A. S.
June 18, a.m.	.....	.....	.....	Fort Ross.....	No time given.
June 20, a.m.	8 10.....	.....	.....	Ferndale.....	Very light, J. A. S.
June 22, a.m.	6 07..... ..... .....	..... ..... .....	..... ..... .....	San Francisco..... Kentfield..... Mt. Tamalpais.....	A. G. McA. No time given. No time given.
June 22, p.m.	11 40..... 11 51 10....	<b>4</b> ..... <b>8</b> .....	..... <b>II-III</b>	Mile Rocks..... Berkeley.....	Slight. Principally vortical. Slight tremors for 5 m. afterwards, no rumble, R. T. C.
	11 51 03....	<b>24</b> .....	.....	do.....	I Omori seismograph, east-west component.
		<b>24</b> .....	.....	do.....	I Omori seismograph, north-south component.
June 25, a.m.	9 16.....	<b>6</b> .....	.....	Ferndale.....	Light, J. A. S.
June 26	..... .....	..... .....	..... .....	Napa..... Peachland.....	No time given. No time given.
June 27	.....	.....	.....	Fort Ross.....	No time given.
June 28	.....	.....	.....	Peachland.....	No time given.
June 30	.....	.....	I	Upper Mattole.....	No time given. About the one hundredth shock since April 18. W. H. Rose.

## Record of after-shocks — Continued.

Day.	Beginning of shock.	Duration.	Intensity.	Locality.	Remarks.
July 1	h. m. s. .....	secs. .....	.....	Mt. Tamalpais___	No time given.
July 2	5 45.....	.....	.....	Fort Bragg.....	a.m. or p.m. not given.
July 4, a.m.	5 35..... 5 39..... 5 45..... 5 45.....	..... ..... ..... .....	I	Los Gatos..... Mt. Hamilton..... Campbell..... Salinas.....	I. H. S. East-west, E. A. F.
July 4, p.m.	1 15..... 1 15..... 10 45.....	..... ..... .....	.....	San Francisco..... Los Gatos..... do.....	A. G. McA. I. H. S. I. H. S.
July 6, a.m.	10 32.....	1.....	.....	Mt. Hamilton___	Two light shocks. Three vibrations, R. G. A.
July 6, p.m.	10 52..... 10 52 15 ± 2	..... 19S..	..... .....	Salinas..... Berkeley.....	Omori seismograph, east-west component. (North-south dismantled.)
	10 55..... 10 58.....	..... .....	..... .....	Mt. Hamilton___ Los Banos..... San Luis Obispo..	Light. East to west, R. G. A. No time given.
July 7, a.m.	4.....	.....	.....	Berkeley.....	Uninterrupted trembling until 6 a.m., R. T. C. and H. F. R.
July 9, p.m.	10 00..... 11 30..... 11 37..... 11 40.....	..... ..... ..... .....	..... ..... ..... .....	Eureka..... Los Gatos..... Eureka..... Ferndale.....	Rotary. Vertical, I. H. S. Very light, J. A. S.
July 12, a.m.	..... 5 38?.....	..... .....	..... .....	Mt. Tamalpais.... San Francisco.....	No time given. A. G. McA.
July 13, a.m.	5 20..... 5 30..... 5 35.....	..... ..... .....	..... ..... .....	Sierra Madre___ Los Angeles..... Newhall.....	Moderate, U. S. W. B.
July 16, a.m.	12 10.....	.....	.....	Los Gatos.....	Northwest-southeast, I. H. S.
July 17, p.m.	3.....	3.....	IV	Palo Alto.....	About 3 p.m.
July 18, a.m.	3 10.....	.....	.....	Los Gatos.....	I. H. S.
July 18, p.m.	6 27 35.....	.....	.....	San Francisco.....	A. G. McA.
July 20, a.m.	1 00..... 1 19 36..... 1 19 42 ± 2	4..... 35.3... .....	..... III	Mile Rocks..... Berkeley..... do.....	Slight. Omori seismograph, north-south component. Omori seismograph, east-west component.
	1 20..... "i 20.....	..... .....	..... .....	do..... Mt. Tamalpais___ San Francisco.....	Sudden jerk apparently from east-west with tremor lasting 3 to 4 s. Awakened from sound sleep, A. O. L. Sharp shock. Dr. J. E. M. No time given. A. G. McA.
July 21, p.m.	10 10.....	.....	.....	Los Gatos.....	North-south. Vertical, I. H. S.
	.....	.....	.....	San Luis Obis-po..	No time given.
July 22, a.m.	9 16.....	.....	.....	S5mi.N.S0°W.from Cape Mendocino	Slight shock reported by Capt. J. R. Sarrins of schooner <i>Espada</i> in Lat. N. 40° 3', Long. W. 128° 15'.

Record of after-shocks — Continued.

Day.	Beginning of shock.	Duration.	Intensity.	Locality.	Remarks.
	h. m. s.	secs.			
July 22, a.m.	9 30.....	6.....	.....	85 mi. N. 86° W. from Cape Mendocino	Lat. N. 40° 33', Long. W. 126° 15'.
July 22, p.m.	10 39 30____ 11 48 20____	60 ±	II	San Jose .....	Horizontal, H. F. R.
July 23, a.m.	5 41..... 11 25.....	.....	II	San Jose .....	Horizontal and vertical motion, H. F. R.
	.....	.....	.....	Los Gatos .....	H. F. R.
	.....	.....	.....	Mt. Tamalpais....	I. H. S.
July 23, p.m.	12 10..... 11.....	.....	.....	Los Gatos .....	No time given.
	4 12.....	.....	.....	Helen Mine.....	I. H. S.
	.....	.....	.....	Los Gatos .....	I. H. S.
July 24, p.m.	6.....	.....	.....	Imperial .....	
July 25, p.m.	11 04 30 ±	60 ±	II	San Jose .....	H. F. R.
July 26, a.m.	4 37 30 ±	30 ±	II	do.....	H. F. R.
July 26, p.m.	9 18 30....	34.....	.....	Berkeley .....	Omori seismograph, east-west component.
	.. ..	19.....	.....	do. (Same record.)	Omori seismograph, north-south component.
	9 20.....	.....	.....	Mills College.....	
July 27, p.m.	10 10.....	.....	.....	Point Loma .....	
July 28, a.m.	12 22 40....	40.....	II	Berkeley.....	H. F. R.
	5 25.....	.....	II	do.....	H. F. R.
	5 44.....	.....	II	do.....	H. F. R.
	6 01.....	.....	II	do.....	H. F. R.
	7 25.....	.....	II	do.....	H. F. R.
	7 46.....	.....	II	do.....	H. F. R.
	.....	.....	.....	Mt. Tamalpais....	No time given.
July 29, a.m.	6 46.....	20.....	II	Berkeley .....	H. F. R.
July 30, a.m.	5 35.....	.....	II	do.....	H. F. R.
	.....	.....	.....	Eureka.....	No time given.
Aug. 1, a.m.	6.....	.....	.....	Peaehland.....	Light.
	11 31.....	.....	.....	Ferndale .....	Very light, J. A. S.
	11 32.....	2.....	.....	Eureka.....	Vibration from southwest.
	.....	.....	.....	San Luis Obispo..	No time given.
Aug. 2, a.m.	6 04.....	.....	.....	Fort Ross.....	G. W. C.
	0 10:.....	.....	.....	Plantation .....	Hard. Rumbling noise from ocean for 2 days.
	6 14-15....	.....	.....	do.....	Slight.
	6 15 ± 5m.	.....	.....	Berkeley .....	Omori seismograph.
	.....	.....	.....	.....	Duration, east-west component 2 m. 48 ± 10 s.
	.....	.....	.....	.....	Duration, north-south component 1 m. 36 ± 10 p.
Aug. 3, p.m.	5.....	.....	.....	Plantation .....	Heavy, f< dlowedbvslight shock.
	5 03.....	.....	.....	F<>t Ross .....	G. W. C. *
	7 05.....	40.....	.....	Gulf of California	Lut. N. 25° 35', Long. 110° 06' i
	.....	.....	.....	.....	W. Ship Alex Gibson. Very
	7 10.....	15.....	.....	do.....	heavy -hock.
	Between	.....	.....	do.....	Lighter shock.
	8 and 12...	.....	.....	do.....	Two more shocks, very light.
	11.....	.....	.....	Plantation .....	Heavy.
Aug. 4, ft.m.	5 39.....	.....	I	Mt Hamilton____	

## Record of aftershocks — Continued.

Day.	Beginning of shock.	Duration.	Intensity.	Locality.	Remarks.
	h. m. s.	secs.			
Aug. 4, p.m.	11 19.....	.....	II	Berkeley.....	Faculty Club, slight vibrations, H. F. R.
Aug. 5, a.m.	1 50..... 1 53.....	..... .....	..... II	Fort Ross..... Berkeley.....	G. W. C. Faculty Club, slight vibrations, H. F. R.
	3 25.....	.....	II	do .....	Faculty Club, slight vibrations, H. F. R.
	6 15.....	.....	II	do .....	Faculty Club, slight vibrations, H. F. R.
Aug. 6, a.m.	10 32 2.....	.....	II	Mt. Hamilton ....	
Aug. 8, p.m.	5 56-57m.. 6 13.....	..... .....	..... .....	Los Gatos .....	I. H. S. <i>i.R. a.</i>
Aug. 12, a.m.	6 00.....	.....	.....	Rio Vista .....	
Aug. 14, a.m.	8 30..... 9 35.....	..... .....	..... .....	Salinas..... do .....	Light. Light.
Aug 15, a.m.	2 07 15.... 4 40 .....	25..... .....	..... .....	Berkeley..... Tequisquita Rancho	Omori seismograph in east- west component.
Aug. 16, p.m.	4 17 58.... 7 45 ship's time	..... 3 m..	..... .....	Berkeley..... Coronel Bay, S, America .....	Omori seismograph. Duration 1 <sup>h</sup> 40 <sup>m</sup> . SS. <i>Rameses</i> .
Aug. 19, a.m.	1 59..... 2 .....	..... .....	..... .....	Salinas .....	Sharp.
	9 .....	.....	.....	Tequisquita Rancho San Francisco	Tremor and jolt, A. G. MeA.
Aug. 21, p.m.	12 15.....	1 m. . .	.....	Lat. N. 26° 19'... Long. 110° 25'....	Gulf of California. Heavy. Bark <i>St. James</i> .
Aug. 22, a.m.	1 55.....	.....	.....	Napa .....	W. H. M.
Aug. 25, p.m.	1 40.....	.....	.....	Ferndale.....	Light shock, J. A. S.
Aug. 26, p.m.	9 09.....	3.....	.....	do .....	Light shock, J. A. S.
Aug. 27, a.m.	10 .....	.....	.....	Point Loma.....	
Aug. 28, a.m.	3 .....	.....	.....	Forndale.....	J. A. S.
	11 40.....	.....	.....	Tequisquita Rancho	
Aug. 29, a.m.	7 59 35....	2.....	.....	Mt. Tamalpais ...	Southeast-northwest, W. W. Thomas.
Aug. 30, a.m.	2 12.....	.....	.....	Sonoma.....	
Aug. 31, a.m.	3 12..... 9 52.....	..... .....	..... .....	do .....	
				Fort Ross.....	
Sept. 1, a.m.	3 12..... 5 50.....	..... .....	..... .....	Sonoma .....	Light shock.
				Tequisquita Rancho	
Sept. 2, a.m.	3 45..... 3 55.....	1 m. . . .....	..... .....	Lat. N. 43° 40'.. Long. W. 128° 50' Lat. N. 43° 40'.. Long. W. 128° 50'	Bark <i>Agate</i> . Heavy. 100 miles west of Coos Bay. Not so severe.
S <sup>^</sup> pt. 6, a.m.	12 10.....	.....	.....	Branscomb.....	A. J. Haun.
Sept. 7, a.m.	6 37..... 9 24 59.... 9 30.....	5-10.. 10 .....	..... II-III	San Francisco____ Mt. Hamilton____ Santa Cruz.....	Very faint, G. K. G. Perceptible vibration. One slight shook. East to west.

RECORD OF AFTER-SHOCKS.

429

Record of after-shocks—Continued.

Day.	Beginning of shock.	Duration.	Intensity.	Locality.	Remarks.
Sept. 8, p.m.	h. m. s. 12 32.....	secs. 20-30.	.....	Berkeley.....	Faculty Club. To and fro motion with period of about 0.5 s., but closed with irregular fluttering motion, G. K. G.
Sept. 9, a.m.	4 15..... 4 55..... 4 55..... 5..... 5.....	.....	.....	Grass Valley..... Carson City..... Pilot Creek..... Nevada City..... Wabuska, Nev.....	Southeast-northwest, J. Sanks. C. W. F. E. W. Stanton. S. W. Marsh. Tremor, J. G. Young.
Sept. 13, a.m.	11.....	.....	.....	Lat. N. 43° 02'... Long. W. 125° 41'	Bark <i>Palmyra</i> , 48 miles W. of Cape Orford.
Sept. 13, p.m.	8 45.....	.....	.....	Ferndale.....	Short, J. A. S.
Sept. 14, a.m.	8 46.....	44 m. . .	.....	Berkeley.....	Omori seismograph, east-west component (origin probably 435 mi. distant).
	.. .. .	25.....	.....	Lat. N. 41° 78'... Long. W. 125° 52'	85 mi. NW. Cape Mendocino. (No time.) Schooner <i>Robert Searle</i> .
Sept. 16, a.m.	7 12 2.....	.....	III?	Mt. Hamilton.....	Several observers give north to south. Duplex showed E. 20° S.
Sept. 17, p.m.	5 15..... 8 10.....	10.....	.....	Ferndale.....	J. A. S. J. A. S.
Sept. 18, p.m.	8 45.....	.....	.....	do.....	J. A. S.
Sept. 20, p.m.	2 20..... 11 39.....	.....	.....	do..... Mare Island.....	From 20° W. of S. movem't   s. Faculty Club. Slight, G. K. G.
Sept. 21, p.m.	11 24.....	.....	.....	Berkeley.....	Faculty Club. Slight, G. K. G.
Sept. 25, a.m.	5 36.....	.....	.....	do.....	Faculty Club. Slight, G. K. G.
Sept. 25-26	.. .. .	.....	.....	do.....	From 5° W. of H. movement   s. (No time.)
Oct. 5, a.m.	6 30.....	.....	.....	Mare Island.....	
Oct. 7, p.m.	11 57.....	.....	.....	San Francisco.....	G. W. C.
Oct. 10, a.m.	5 45.....	.....	.....	Fort Ross.....	
Oct. 10, p.m.	11 45.....	.....	.....	Tequisquita Rancho	
Oct. 11, a.m.	5 30.....	.....	.....	San Francisco.....	
Oct. 15, p.m.	2 49.....	.....	.....	Salinas.....	Omori seismograph.
Oct. 17	.. .. .	.....	.....	Berkeley.....	During night, G. W. C.
Oct. 18, a.m.	5.....	.....	.....	Fort Ross.....	
Oct 24, a.m.	8 45 10....	.....	.....	Tequisquita Rancho	Omori seismograph.
Nov. 4, a.m.	11 58.....	.....	.....	Berkeley.....	
Nov. 6.	.. .. .	2-3....	.....	Fort Rosa.....	No time given. Sharp, followed by 3 mountainous waves 55 mi. W. of Cape Disappointment Schooner <i>Stanley</i> .
Nov. 7	.....	.....	.....	Eureka.....	No time given.

## Record of after-shocks—Continued.

Day.	Beginning of shock.	Duration.	Intensity.	Locality.	Remarks.
Nov. 9, a.m.	h. m. s. 2 .....	secs. .....	.....	Fort Bragg.....	
Nov. 11, a.m.	6 40 ship's time	.....	.....	Lat. N. 42° 51'... Long. W. 127° 51'	Ship received a quick rolling motion, and a few seconds after trembled fore and aft. Bark <i>Carondelet</i> .
Nov. 12, a.m.	.....	.....	.....	Salinas .....	Light.
Nov. 13, a.m.	.....	.....	.....	Fort Bragg.....	
Nov. 13, p.m.	7 47 49... 7 48..... 7 48..... 7 48.....	..... ..... ..... 3.....	..... ..... ..... .....	Mt. Hamilton .... Glenwood..... Tequisquita Rancho San Jose".....	One jolt. North to south. Sharp. East to west.
Nov. 14, a.m.	2 30.....	.....	.....	Fort Bragg.....	
Nov. 14-15	.....	.....	.....	Fort Ross .....	During night.
Nov. 16, a.m.	12 30.....	.....	.....	Berkeley.....	Short tremor, G. K. G.
Nov. 22, p.m.	3 53..... 10 45.....	..... .....	..... .....	Glenwood .....	Isabella.....
Nov. 25, p.m.	1 15.....	.....	.....	San Francisco....	Very light.
Nov. 26, a.m.	.....	.....	.....	do.....	No time given,
Nov. 26, p.m.	10 27.....	8-10..	.....	Lat. N. 14° 41'... Long. W. 92° 36'	Sharp shock. About 20 mi. off coast of Guatemala. S.S. <i>Newport</i> .
Dec. 2, a.m.	1 19..... 2 23.....	..... .....	..... .....	Berkeley .....	do.....
Dec. 6, a.m.	6 45.....	.....	.....	Tequisquita Rancho San Luis Obispo..	First stronger, G. K. G. Increasing in strength, with regular horizontal oscillation with period estimated at about 0.5 s. Became irregular toward end, giving sense of fluttering, but superposed on the irregular motion was a regular beat with an estimated period of 1 s., G. K. G. No time.
Dec. 7, p.m.	10 55.....	.....	.....	San Miguel.....	
Dec. 8, a.m.	10 40.....	.....	.....	Idyllwild .....	
Dec. 8, p.m.	5 48 54.....	2.....	.....	Mt. Tamalpais___	Light shock.
Dec. 9, a.m.	3 20..... 4 20..... 3 20..... 3 20 40....	..... ..... 20..... 6.....	..... ..... ..... .....	San Francisco___ Mills College..... Berkeley..... Oakland.....	Duration a few seconds. One marked wave southwest to northeast;*, A. G. MeA. J. Keep. Southwest-northeast. Light, C. B.
Dec 19, ]»ssJ	2 40..... 3.....	..... .....	..... .....	Esconditlo .....	Cuyainieu.....
Dec. 22, u m.	S 4">.....	.....	.....	Culexio.....	
Dw. IW, u HI.	4..... 4 55..... 5 48..... 9 26 35.....	..... ..... ..... .....	..... ..... ..... .....	Cuytuuea..... Culexio..... Fort IW..... Berkeley.....	Onmri seismograph, east-west component only.

Record of aftershocks — Continued.

Day.	Beginning of shock.	Duration.	Intensity.	Locality.	Remarks.
Dec. 24, a.m.	h. m. s. 2 .....	secs. .....	.....	Napa .....	Sharp jar.
Dec. 25, p.m.	8 15..... 8 18.....	.....	.....	Rohnerville .....	
				Eureka.....	
Dec. 28, a.m.	.. .. .	.....	.....	Lytle Creek .....	In the early morning. Light.
1907.					
Jan., 1 p.m.	11 00.....	.....	.....	Kentfield .....	
Jan. 4, a.m.	3 20.....	.....	.....	Santa Cruz.....	Regular rocking motion. First north-south, F. L.
Jan. 5, p.m.	5 to 6.....	.....	.....	Fort Ross.....	
Jan. 6, a. in.	3 15.....	.....	.....	Salinas.....	
Jan. 7, p.m.	9 20..... 10 48 55..... 11 03..... 11 05.....	..... ..... ..... 4.....	..... ..... ..... .....	Idyllwild..... Berkeley..... do .....	Oniori seismograph. G. K. G. First shock, then short, ominous lull, followed by quick vicious shaking and twisting, which lasted not more than 4 s. Seemed to come from north-west, F. L.
	11 05.....	.....	.....	Campbell .....	Sharp, No damage.
	11 05.....	.....	.....	Niles .....	
	11 05.....	.....	.....	Salinas .....	
	11 10.....	.....	.....	Los Gatos .....	I. H. S.
	11 10.....	.....	.....	San Francisco .....	
	11 20.....	.....	.....	Glenwood .....	
	.. .. .	.....	.....	Boulder Creek....	Hour not given.
Jan. 8, p.m.	3 45..... 4 31 36.....	..... 10.....	VI .....	Santa Cruz .....	Sharp jolt, F. L.
				Berkeley.....	Omori seismograph, east-west component only.
Jan. 9, p.m.	12 39 42....	101.....	.....	do.....	Omori seismograph, north-south component only.
Jan. 10, p.m.	3 21.....	.....	.....	Idyllwild .....	
Jan. 13, a.m.	4 50.....	.....	.....	Blocksburg .....	
Jan. 14, a.m.	4 50.....	.....	.....	Eureka .....	Light.
Jan. 14, p.m.	4 23 35.....	.....	.....	Berkeley .....	Omori seismograph, north-south component only. Duration 18 in. 15 s.
Jan. 18, p.m.	11 45.....	.....	.....	Idyllwild .....	
Jan. 19, a.m.	7 05..... 9 36 00..... 9 35 45.....	..... 24..... 23.....	..... ..... .....	Isabella .....	Light.
				Berkeley.....	Omori seismograph, north-south component.
				Berkeley.....	Omori seismograph, east-west component.
Jan. 23, a.m.	10 53.....	7.....	.....	do.....	Omori seismograph, east-west and north-south components.
Jan. 25, a.m.	9 25 38..... HI :B Art..... lo r,t; 12.....	90..... 60..... 133.....	..... ..... .....	do..... do..... Berkeley.....*	Omori seismograph, north-south component only. Omori seismograph, north-south component only. Omori seismograph, north-south component only.
					Mjulli röjupjient (>nly.

## Record of aftershocks — Continued.

Day.	Beginning of shock.	Duration.	Intensity.	Locality.	Remarks.
Jan. 25, p.m.	h. in. s.	<i>secs.</i>			
	3 24 18. ....	.....	.....	Berkeley.....	Omori seismograph, north-south component.
	3 24 18. ....	.....	.....	do.....	Omori seismograph, east-west component.
	3 57 18. ....	.....	.....	do.....	Omori seismograph, east-west and north-south components.
Jan. 26, a.m.	10 13 47....	27.....	.....	do.....	Omori seismograph, north-south component.
	10 14 08....	10.....	.....	do.....	Omori seismograph, east-west component.
	10 24 49....	<b>30</b> .....	.....	do.....	Omori seismograph, north-south component only.
Jan. 28, p.m.	2 42 18....	39.....	.....	do.....	Omori seismograph, north-south component only.
	4 16 54....	.....	.....	do.....	Omori seismograph, north-south component. Slight irregular shifts.
	4 18 44....	.....	.....	do.....	Omori seismograph, east-west component.
Jan. 29, p.m.	5 00 32....	.....	.....	do.....	Omori seismograph, north-south component.
	5 00 32....	.....	.....	do.....	Omori seismograph, east-west component.
Jan. 30, p.m.	2 .....	.....	.....	Kentfield.....	
	2 41 11:....	.....	.....	Berkeley.....	Omori seismograph, Both components.
	<b>3</b> .....	.....	.....	San Francisco___	
Jan. 31, a.m.,	12 30.....	.....	.....	Kentfield.....	
	0 27.....	.....	.....	Mills College.....	
	12 30.....	.....	.....	Sonoma.....	Light.
	12 30 18....	64.....	.....	Berkeley.....	Omori seismograph, north-south component.
	12 30 32....	86.....	.....	do.....	Omori seismograph, east-west component.
	12 33.....	.....	.....	Niles.....	
	12 33.....	.....	.....	San Francisco___	
	12 35.....	.....	.....	San Jose.....	Sharp.
	12 35.....	.....	.....	Napa.....	
	12 36 06....	.....	III	Berkeley.....	Awoke people in my house, R. T. C.
.....	.....	.....	Boulder Creek___	No hour given.	
Feb. 3, a.m.	10 30.....	<b>8</b> .....	.....	Lat. N. 37° 35'....	Neither shock was violent, but a decided trembling motion east-west, 28 geo. mi. S. 73° W. from SB. Farallon, Schooner <i>Melrose</i> .
	10 50.....	<b>5</b> .....	.....	Long. W. 123° 35'	
Feb. 3, p.m.	7 55.....	.....	.....	Livermore.....	
Feb. 5, a.m.	4 25.....	.....	.....	La Porte.....	
Feb. 13, a.m.	<b>10 50</b> .....	.....	.....	Livermore.....	
Feb. 14, a.m.	6 45.....	.....	.....	do.....	
Feb. 16, a.m.	2 09 30....	.....	.....	Point Loma.....	
Feb. 25, a.m.	5 16 40....	.....	.....	Eureka.....	



*Record of after-shocks—Continued.*

Day.	Beginning of shock.	Duration.	Intensity.	Locality.	Remarks.
Mar. 11, p.m.	h. m. s. 11 58.....	secs. 20....	.....	Berkeley.....	Faculty Club. In bed at time, 3 phases. First more than one-half total time, rapid tremor. Period averaging less than 0.25 s. Second about one-half total time. Higher intensity. Motion less irregular, period estimated at 0.5 s. Third, comparatively short. Motion irregular. Average period shorter than second phase. Intensity at first same as second phase, but rapidly declined, G. K. G.
Mar. 24, a.m.	5 56 04....	.....	.....	do.....	Omori seismograph, north-south component.
	5 56 06....	.....	.....	do.....	Omori seismograph, east-west component.
Mar. 30, p.m.	2 28 22....	17..	.....	do.....	Omori, north-south component.
	2 28 22__	9..	.....	do.....	Omori, east-west component.
Apr. 14, p.m.	10 40.0.....	21 0..	.....	do.....	Omori, north-south component.
	10 32.2m....	37 2..	.....	do.....	Omori, east-west component.
May 12, a.m.	10 21 31__	26..	.....	do.....	Omori, north-south component.
	10 21 31__	24..	.....	do.....	Omori, east-west component.
June 5, a.m.	12 26 37....	03..	.....	do.....	Omori, north-south component.
	12 26 37....	53..	.....	do.....	Omori, east-west component.
	12 26 36....	35..	IV-V	do.....	Observatory, R. T. C.
	12 26 41....	.....	.....	do.....	Observatory, S. E.
June 10, a.m.	9 47 51....	1 47..	.....	do.....	Omori, north-south component.
	9 47 51....	2 32..	.....	do.....	Omori, east-west component.
	9 47 55....	.....	.....	do.....	At Faculty Club, S. E.
	9 48 05....	30..	.....	do.....	At home. Asleep, A. O. L.
	9 47 47....	.....	III	do.....	2011 Bancroft Way, R. T. C.
	11 10 48__	.....	.....	do.....	Omori. (Doubtful shock.)

KEY TO INITIALS.

R. G. A. = R. G. Aitken  
 S. A. = S. Albrecht  
 W. B. = William Barry  
 A. H. B. = A. H. Bell  
 C. B. = Charles Burkhalter  
 K. B. = K. Burns  
 G. W. C. = G. W. Call  
 W. W. C. = W. W. Campbell  
 R. T. C. = R. T. Crawford  
 N. E. = Nelson Eekart

W. R. E. = W. R. Eekart  
 S. E. = S. Einarson  
 E. A. F. = E. A. Fath  
 C. W. F. = C. W. Friend  
 G. K. G. = G. K. Gilbert  
 A. M. H. = Adelaide M. Hobe  
 J. N. LeC. = J. N. LeConte  
 A. O. L. = A. O. Leuschner  
 F. L. = Finette Locke  
 J. D. M. = James D. Maddrill

W. H. M. = W. H. Martin  
 A. G. McA. = A. G. McAdie  
 B. L. N. = Burt L. Newkirk  
 C. D. P. = C. D. Perrine  
 J. G. P. = J. G. Plummer  
 H. F. R. = H. F. Reid  
 J. A. S. = J. A. Shaw  
 B. S. = E. Smith  
 I. H. S. = Irving H. Sayder  
 S. D. T. = S. D. Townley

## COMPARISON WITH OTHER SEVERE EARTHQUAKES IN THE SAME REGION.

---

### THE EARTHQUAKE OF 1868.

The earthquake of October 21, 1868, was most severely felt in the region about San Francisco Bay, particularly on the east side in the vicinity of Haywards. The time of its occurrence is variously stated from 7<sup>h</sup> 47<sup>ra</sup> to 7<sup>h</sup> 54<sup>m</sup> A. M. It gave rise to disasters in the city of San Francisco, and some people recalling the event vividly are of the opinion that the shock was as severe as that of April 18, 1906. Early in the investigation of the latter earthquake, it became apparent that the relationship of the two earthquakes would be an essential part of the inquiry. Shortly after the earthquake of 1868 a committee of scientific men undertook the collection of data concerning the effects of the shock, but their report was never published nor can any trace of it be found, altho some of the members of the committee are still living. It is stated that the report was suppressed by the authorities, thru the fear that its publication would damage the reputation of the city. Our knowledge of that earthquake is therefore not very full, and is contained chiefly in the newspaper reports of that day. A summary of this data is given in Holden's Catalogue of Earthquakes,<sup>1</sup> and by Griesbach.<sup>2</sup>

With the object of supplementing the facts regarding the earthquake of 1868 recorded by Holden, for the purpose of comparing it with that of 1906, an inquiry was started and intrusted to Mr. A. A. Bullock. This gentleman has reviewed the periodicals of the time, and has interviewed many people who experienced the shock. He has also examined the region of maximum intensity, and has had, on several of his trips, the guidance of old residents. In response to a request by the Commission, several people have written an account of their experiences at the time of the earthquake of 1868. In this way a considerable body of valuable information has been gotten together, which supplements to an important degree the extant accounts of that earthquake.

### THE FAULT-TRACE.

It appears from Mr. Bullock's inquiries that the earthquake of 1868 was due to an earth-movement along the base of the hills which overlook San Francisco Bay on the east, and which are often referred to, particularly farther north, as the Berkeley Hills. Those hills present a remarkably even, straight front, and without doubt represent a degraded fault-scarp. Along the base of this scarp a crack opened on the morning of October 21, 1868. This crack is regarded as the trace of the fault which caused the earthquake. Its position has been determined at intervals along a nearly straight line from the vicinity of Mills College, east of Oakland, to the vicinity of Warm Springs near the Santa Clara County line; but the evidence of its existence to the northward of San Leaulro is not very satisfactory. The county was then unsettled, and the information consisted of reports of cow-boys riding the range. From San Leandro southeastward, however, the evidence is full and conclusive. The general trend of the fault is north-west-southeast; or, to be more exact, N. 37° W., a bearing almost the same as that of

---

<sup>1</sup>Smithsonian Misc. Coll., vol. xxxvii, 1898.

<sup>2</sup>Mitt. .1. k. k. Meuiograph. <ICM-IIM-II. in Wicn, Bund xii, IN(!>, pp. 22;i \*\_{ 1.

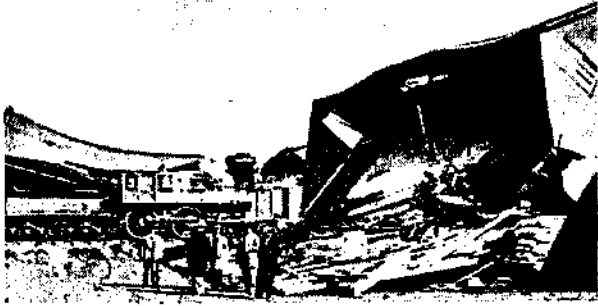

A. Flour mill, Eaywards, Wrecked 'by earthquake of 1868.

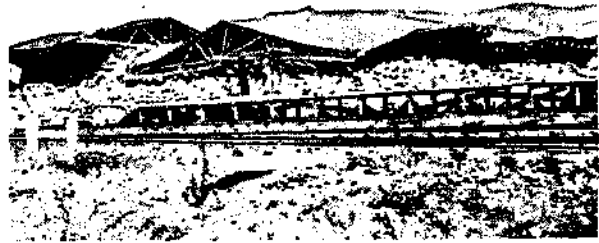

B. Edmouson's warehouse, Haywards, "Wreckedby earthquake of 1868.

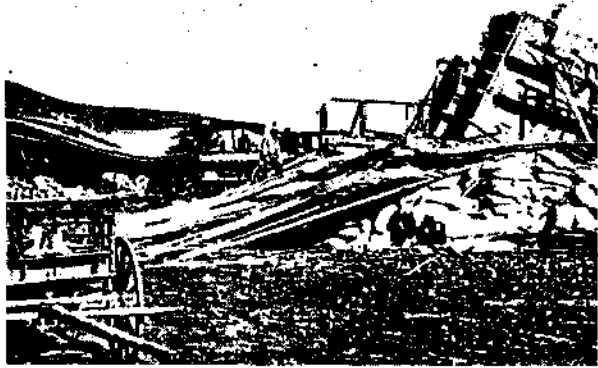

0. Flour mill and warehouse, Haywards. Wrecked by earthquake of 1868.



D. Pieroe's house, Haywards, Earthquake of 1868.



E. Haywards. Wreck of buildings by earthquake of 1868.

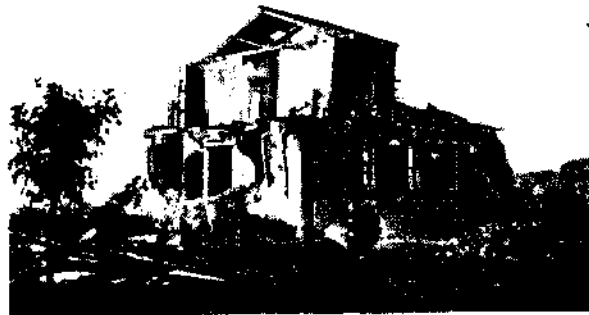

P. Ocirt-iwase, Saa L«wdrQ. Wrecked by earthquake of 1868.

From photographB presarred /hj Mr. H» Beafel,

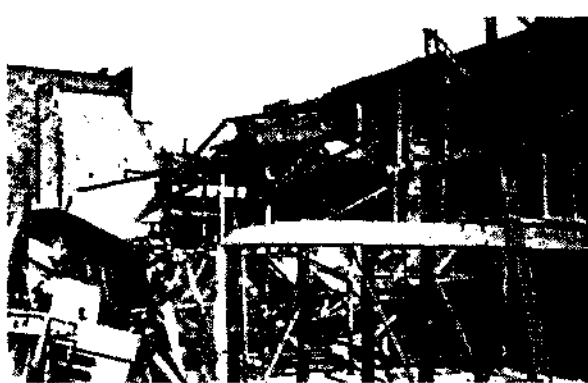
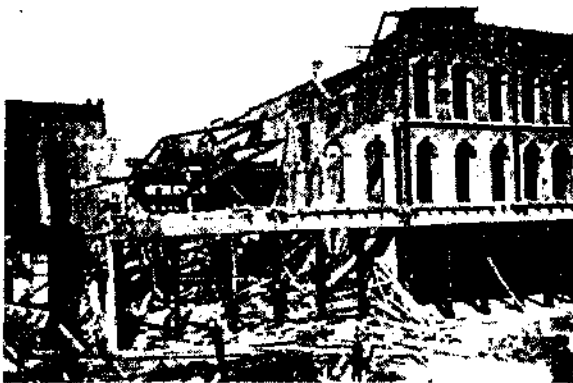
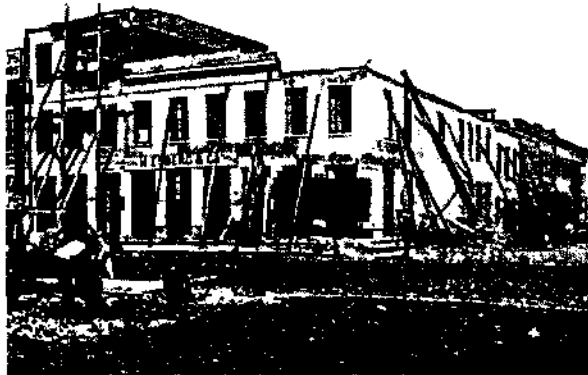
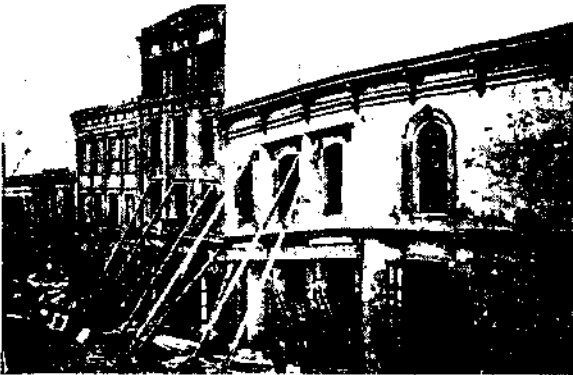

Effects of the earthquake of 1885 in San Francisco, from photographs published by Mr. E. Beadel.

the fault-trace of 1906 along the San Andreas Rift. The position of this fault-trace is shown on map 4. While in general it lies along the base of the old degraded scarp, it is still, for the most part, within the hill-slopes and not in the alluvium which extends from the base of the hills. In some places where it crossed the lower ground, the crack showed faulting or displacement of 8 or 10 inches, but from the accounts given it is not clear in what direction the faulting took place. The statements indicate a slight down-throw on the southwest side. In other places a displacement of 3 feet is said to have been observed. In places the crack along the fault-trace opened to a very considerable depth with a width of 10 or 12 inches, and remained open until filled with falling earth. On the higher ground of the hill-slopes no open crack was observed; there was merely the trace of the rupture in the sod. This fault-trace could be followed at intervals for 20 miles southeast from San Leandro, and it had a straight course without regard to the contour of the hills. In some places it was quite at the bottom of a hillside, while at other places it was high on the slope; and on at least one low hill it passed near the top through a saddle-like depression. Springs are common along the base of the hills, and the fault-trace was above the springs. According to the testimony of old residents the flow was not affected by the earth-movement.<sup>1</sup> In the hills to the northeast of the fault-trace, however, new springs were started and old ones revived, although some few ceased flowing.

That the crack extended down into the bedrock is testified to by many who observed closely. Three men reported that they tried to sound the bottom of the crack, but were unable to do so. In the vicinity of Haywards it is reported that there were two branch cracks from the main one, trending off into the hills. Water and sand were ejected from the crack in one place.

Between Decoto and Niles the crack left the base of the hill front, and deviating slightly from its general trend thus far, crossed the plain of the alluvial fan of Alameda Creek at the mouth of Niles Canyon to the foot-hills at the town of Irvington. For the greater part of this distance, it appeared as an open crack. It passed through a lagoon about 0.5 mile in length, following closely the longer axis of the depression, and the water of the lagoon was drained out, apparently into the crack. At Irvington the crack became coincident with the very straight and even ancient fault-scarp of the foot-hills southeast of that town. This ancient scarp has a strike of N. 38° W. Beyond this it was not observed farther than Aqua Caliente Creek.

Immediately to the east of Mission San Jose, entirely within the hills, another crack opened with a strike of N. 18° to 20° W.; which, converging upon the crack thus far traced, extended south as far as the county line.

The greatest intensity of the earthquake was along the crack and in its vicinity. On the projection of this line southward into Santa Clara County, the intensity diminished steadily as far as Morgan Hill, where it again rose. At Gilroy, Hollister, and San Juan, according to reports, the intensity was sufficient to throw down a few chimneys and to crack some brick and adobe buildings.

The greatest damage was done at Haywards, where nearly every house was thrown off its foundations; while at San Leandro the shock was less severe. (See plate 144.) A house near old Blair Park, in the present Piedmont district of Oakland, was badly damaged. The only other town of that date in close proximity to the fault-trace was Mission San Jose, which lies in the hills a few hundred yards west of it. In this town were several adobe buildings, one of which, a church, was wrecked. Many chimneys were thrown, but the general effect was much less severe than at Haywards.

<sup>3</sup> Tin- m>ntl<:ncr who chiefly aided Mr. Bullock in tracing out this crack were W. Smith, S. Huff, and Mr. Carthy, of San Leandro; Messrs. O. Hill, F. F. Allen, F. W. Deane, and H. V. M. M. U. of Haywards; Mr. Deruti, of Derotu; and Mr. W. Berry, of Niles.

In general, the direction of throw of objects was north or south. From several tanks the water sloped north and south. Nearly all the chimneys reported were thrown either north or south. Several frame houses were thrown south. One of these, 0.5 mile south of the line of the fault, was thrown 4 feet and another on the line was violently thrown 6 feet.

Several people report that rumblings preceded the shock, coming apparently from the south or southwest. Others saw a wave-like motion set up in the surface of the ground approaching from the south or southwest.

#### THE EFFECT OF THE EARTHQUAKE IN SAN FRANCISCO.

At San Francisco and nearby points the earthquake lasted for about 42 seconds. It was in general north and south.<sup>1</sup> A second shock followed the first at 9<sup>h</sup> 23<sup>m</sup> A. M., and lasted for 5 seconds, with the same direction as the first. Until about 12<sup>h</sup> 15<sup>m</sup> P. M., light shocks continued to be felt about every 30 minutes; and inside of the 24 hours immediately following the initial shock, 12 minor shocks were felt. The first indication of the approach of the earthquake was a slight rumbling sound, coming apparently from the direction of the ocean. The sound was heard very distinctly in the lower part of the city, but the residents on the hills do not appear to have heard it. (*San Francisco Times*, Oct. 21.) The shock commenced in the form of slow, horizontal movements. The oscillations continued from 10 to 15 seconds, growing more rapid and more violent for 6 or 7 seconds, then partially ceasing for 3 or 4 seconds, then increasing in force and rapidity for 4 or 5 seconds, then suddenly ceasing. (*Alta California*, Oct. 22, 1868.)

There were no abnormal barometrical changes at the time of the earthquake. No chronometer in Mr. Tennent's office was disturbed or showed any change of rate. The pendulum clock in his office was not stopped. A transit instrument erected on Russian Hill, belonging to him, was not disturbed in the slightest degree. Two magnets, one in his office and one in charge of a friend, showed no loss of magnetic power. One was loaded to its full extent, and the slightest loss of power would have permitted the weight to fall. (*Bulletin*, Oct. 22, 1868.)

The portion of the city which suffered most was that part of the business district, embracing about 200 acres, built on "made ground"; that is, the ground made by filling in the cove of Yerba Buena. (See plates 145 and 146.) The bottom of this cove was a soft mud varying from 10 to 80 feet in depth, and the material used to fill it was largely "dump" refuse, much of which is organic and hence perishable. Many of the buildings of that period were built flat on this filled mud, without piling, and before the land had had time to become firm. On this made land there was a very evident belt of maximum damage several hundred feet wide and running about northwest and southeast, commencing near the custom-house and ending at the Folsom Street wharf. One account of this belt goes so far as to trace 8 or 10 distinct lines of maximum disturbance, practically every building on these lines being more or less damaged, while none outside of these lines was seriously injured.

In many places the made land settled. At the junction of Market and Front Streets, the ground sank for a foot or two, and there was evidence that the tide had risen in the adjoining lot at the same time, for a pond of water collected and remained until low tide. On Pine Street, near Battery, the cobbles on the south side of the street sank away from the curbstones to the depth of 1 foot in some places; and the asphalt sidewalk on the north side was twisted and torn out of all shape, and its connection with the curb-stone severed. (*Alta California*, Oct. 22, 1868.)

<sup>1</sup> Tennent, Tinent U.S. Coast Survey, in *Alta California*, on Oct. 22, 1868, reports it as lasting 40 seconds and moving from southeast to northwest (nearly) in direction.

M A P  
O F A  
P O R T I O N O F S A N F R A N C I S C O  
S H O W I N G  
T H E D I S T R I B U T I O N A L D E G R E E O F D A M A G E  
C A U S E D B Y T H E  
E A R T H Q U A K E O F 1 8 6 8  
I N R E L A T I O N T O T H E M A R S H L A N D



«PBA»pa+£KB

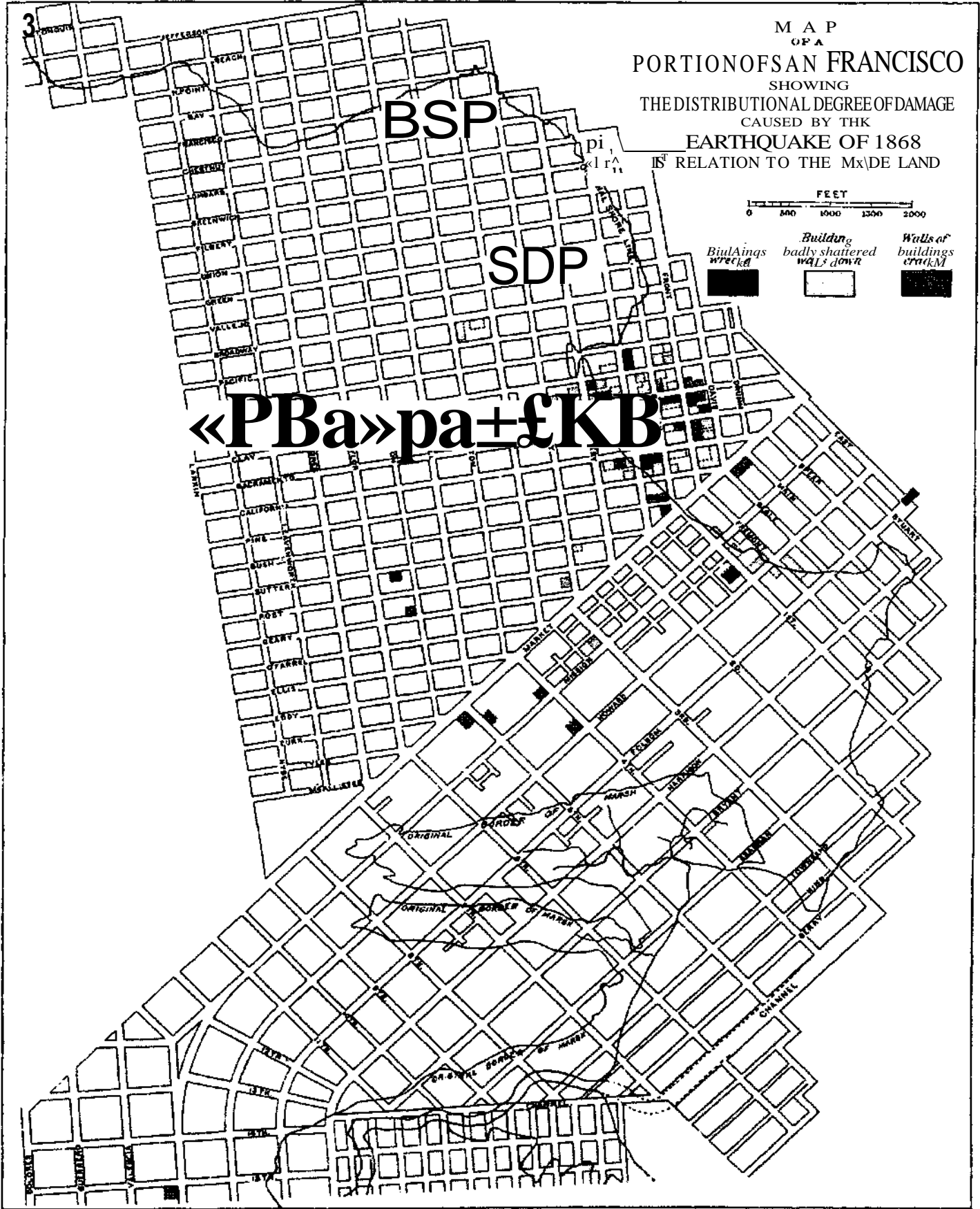

At the corner of First and Market Streets, the ground opened in a fissure several inches wide. At other places the ground opened and water was forced above the surface. (*San Francisco Bulletin*, Oct. 21, 1868.) At Fremont and Mission Streets the ground opened in many places. (*Alta California*, Oct. 22, 1868.) The general course of damage in the city was along the irregular line of the "made land," or low alluvial soil, where it met the hard or rocky base beneath it. Along the line of the old shore of Yerba Buena Cove, we found the damage to brick buildings much the largest. (George Davidson.) The custom-house, at the corner of Sansome and Clay Streets, was hurled south, by what seemed to be an undulating motion, and plaster fell. (*Bulletin*, Oct. 22, 1868.)

The outstanding portico on the east side of the custom-house was so badly shattered that it had to be removed; the main building stood fairly well, but one of the chimneys was broken across at the roof-line and turned thru an angle of over 45°. (George Davidson.)

The ground floor and the foundation of the old Merchants' Exchange appeared to have taken a different motion from the upper portion. The arch over the main corridor appeared to have been crushed. Just underneath the center, the matting was raised 2 inches. The corresponding arch at the south end of the corridor was also damaged, and there was a similar protuberance under the matting beneath it. Smaller arches at right angles to the main arches described were crushed in similar fashion. The north and south walls of the building, at the second floor, over the main arches, opened in large cracks. (*Bulletin*, Oct. 22, 1868.)

A 3-story brick structure on the corner of Market and Battery Streets, in an unfinished condition, was completely thrown down. Several different reports state, however, that it was very poorly constructed. In the Union Foundry, on First Street at the corner of Market Street, most of the machinery was displaced. (*San Francisco Bulletin*, Oct. 21, 1868.)

The floor of the Pacific foundry was raised about 2 feet in places. The center of Mission Street (opposite Fremont Street) exposed an opening from 8 to 10 inches wide; and openings of the ground were also plainly to be seen on Fremont Street, in the same vicinity. (*San Francisco Bulletin*, Oct. 21, 1868.)

Outside of the immediate district described above, damage to the rest of the city was very meager. It will be noticed in the following notes, and by a consultation of the map of San Francisco, plate 146, that the region of greatest agitation was confined to the low portions of the city, or the vicinity of some old creek bed or swamp.

The flat between Howard Street and Mission Bay was more severely shaken than Russian and Telegraph Hills; but the damage, save to chimneys and plaster, was slight. The only serious injury on Kearney Street was done to a building on the east side of the street. The building was an old one. At the corner of Fifth and Market Streets a fire-wall was thrown down. At the corner of Fourth and Bryant Streets, walls were cracked and damaged; Fourth Street near Bryant opened in places and at the crossing of Harrison and Fourth the railroad track settled about 8 inches, the planks between the rails rising about 10 inches. The Lincoln School-house (east side of Fifth Street near Market Street) was badly damaged, most of the chimneys being broken but none thrown down. The large statue of Lincoln in front of the building was ruined, but was not thrown off its pedestal. (*San Francisco Bulletin*, Oct. 21, 1868.)

The large chimney of the sugar refinery on Eighth Street fell in, crushing thru the ceilings. (Letter to *New York Times*, Oct. 21, 1868.)

A drug store at the corner of Fifth and Folsom Streets had its entire stock destroyed by falling. The chimneys of the Mission Street public school (west side of Mission Street between 15th and 16th Streets) toppled off some bricks. (*Alta California*, Oct. 21, 1868.)



A part of the brick walls of the new Calvary Church (Geary and Powell Streets) fell. A small crevice opened, as in 1865, on Howard Street beyond Sixth Street. No damage was sustained by the dry-dock at Hunter's Point. On the beach at the foot of Webster Street, below high-water mark, a fissure opened, extending lengthwise with the water. The stream of a sewer running from the Laguna to the foot of Webster Street into the bay, hitherto clear, immediately turned inky black. (*Alta California*, Oct. 22, 1868.)

The sugar refinery at North Point, a 7-story brick structure, surmounted by a tall brick chimney, was injured to the extent of losing 6 or 7 feet of its 100-foot chimney. A large fissure was made in the high bank near Fort Point and the shock was felt severely at the Fort. (*San Francisco Times*, Oct. 22, 1868.)

At the Cliff House nothing unusual took place, with the exception of a decided commotion in the ocean and "an impetus given to the every-day wave which sent it well inland, say 15 or 20 feet above the usual mark. The shock, however, did no damage, not even upsetting any of the glassware in the bar. (*Alta California*, Oct. 22, 1868.)

Upon Russian and Telegraph Hills the shock was not very damaging. In some houses on the latter ornaments were not displaced from the mantel and the inmates did not come to the doors. In others, books and ornaments fell down and marble mantels were started from their places. The oscillations on Russian Hill were more severely felt. There was a pretty general stopping of clocks, some cracking of plaster, and throwing down of light articles. (*San Francisco Bulletin*, Oct. 21, 1868.)

A pail of water, two-thirds full, on the ground at the summit of Russian Hill, slopt over both sides. (*Alta California*, Oct. 22, 1868.)

The colored Masonic Hall, Stockton Street between Pacific and Broadway, a 2-story brick structure, was badly wrecked. (*San Francisco Times*, Oct. 22, 1868.)

From the meagerness of reports it is certain that no great loss "was occasioned by the parting of water mains. The *Bulletin* for October 21 reports that the water at the Mission was shut off by the pipe being disconnected. In several parts of the city the water-pipes broke underground and caused some loss of water, but the water company soon had all repairs made. No fires are reported in the upper Mission district during the 24 hours following the earthquake. At Laguna Honda (a natural reservoir and the chief source of water supply, 2.5 miles west of Valencia and Market Streets) the water was violently agitated and the waves met in the center, throwing up a large jet several feet into the air. (*Alta California*, Oct. 22, 1868.)

The first alarm of fire was given shortly after 8 o'clock from Box No. 26 (northeast corner of Clay and Battery Streets). The fire was in Wellman and Peck's grocery (Front and Clay Streets) and was caused by matches. The chief damage was caused by water.

During the night following the earthquake, three fires occurred in the wholesale district, but there was no lack of water and all were quickly extinguished.

In the Fire Commissioner's report in the Municipal Records of San Francisco for 1868-1809, the following losses by fire are recorded: September, 1868, \$24,229; October, 1868, \$133,564.46; November, 1868, \$19,920; December, 1868, \$82,019.

The force of the shock was distinctly felt on the bay and as far as 15 miles Avost of the heads, but no great agitation of the water is reported. The tide-gage at one of the Government stations indicated no unusual rising of the tide. (*San Francisco Times*, Oct. 22, 1868.)

There was no tidal wave accompanying the earthquake. The passengers on a ferry steamer (off Angel Island) felt the shock and supposed for the time that they were aground. Many other boats reported the same experience. Two boatmen in a Whitehall boat off Fort Point report a heavy rumbling sound coming from the water. Their boat was shaken and whirled rapidly around (before the rollers reached them) and shortly they met 3 heavy rollers coming from the northwest on a calm sea. (*Alta Call-*

*fornia*, Oct. 22, 1868.) The shock of the earthquake was distinctly felt at sea near San Francisco. Captain Tobey, of the ship *Pactolus*, reported being at anchor in deep water about 15 miles west of the Heads when the shock took place. At first it seemed as if the vessel were passing over a coral shoal and striking quite heavily. The noise and motion made it seem as if the ship were dragging, with her chains also slipping out. (*San Francisco Bulletin*, Oct. 22, 1868.) The ship *Cesarewitz* felt the shock nearly out at the Farallones; the brig *Orient*, bound in, 8 miles out, experienced the shock heavily. Pilot Murphy, on a transport bound out, reported that the bark seemed to have struck bottom, her progress being impeded; and the ship, especially the yards and masts, trembled violently. (*San Francisco Times*, Oct. 22, 1868.)

The total list of casualties due directly to the earthquake numbered 5, and about 25 more occurred from secondary causes. The total loss of property was variously stated from \$300,000 to \$5,000,000. However, a careful estimate of damages made a day or two after the disaster, placed it at about \$350,000. (*San Francisco Bulletin*, Oct. 23, 1868.)

#### THE DISTRIBUTION OF INTENSITY THRUOUT THE STATE.

*Healdsburg*. — A good shaking. Heaviest shock ever felt. (*Democratic Standard*, Oct. 24, 1868.) Lasted about 10 seconds. Vibrations north and south. Clocks stopt. (*Alta California*, Oct. 22, 1868.)

*Guemerville*. — The earthquake was of great severity. It frightened my horse and he started to run away; but a large tree which had been cut nearly thru by choppers, and which they felled a few moments after the shock, was not overthrown by the shock. (I. E. Thayer.)

*Santa Rom*. — Severest shock yet felt. Lasted 10 seconds. Nearly all brick buildings in town more or less injured. Many chimneys down. (*Alta California*, Oct. 22, 1868.)

Violent and somewhat protracted earthquake. Vibrations at first from west to east, but suddenly changed from south to north, and continued about a minute. Damage to property considerable. Several brick buildings cracked. At Windsor it was lighter than in Santa Rosa, and farther north still lighter. At Sonoma, Sebastopol, Bodega, and elsewhere, the shock was severe but little damage was done. (*Santa Rosa Democrat*, Oct. 26, 1868.)

*Petaluma*. — Vibration north to south, 10 seconds in duration. Several brick buildings injured and many chimneys. (*Alta California*, Oct. 22, 1868.) Oscillations from east to west; 3 distinct shocks lasting in all 10 to 15 seconds. (*Petaluma Argus*.)

*San Rafael*. — Terrible shock. Vibrations southeast to northwest, for fully a minute. (*Alia California*, Oct. 22, 1868.)

*Napa*. — Violent shock in northeast direction for 30 seconds, accompanied by low rumbling sound. Some slight damage. (*Alta California*, Oct. 22, 1868.)

Most severe shock ever felt. Lasted 40 seconds. No serious damage to buildings. Five miles west of Napa a number of trees were overthrown. (*Napa Reporter*.)

*Vallejo*. — Earthquake severe. Many chimneys down. (*Alta California*, Oct. 22, 1868.) Heaviest shocks ever felt in Vallejo. One chimney and some plaster down. Dishes thrown from shelves. Bay smooth. (*Vallejo Recorder*.)

*Mare Island*. — Chimneys were thrown, and some buildings were considerably shaken. Shock accompanied by rumbling sound.

*Chico*. — A perceptible moving of the earth. Lamps and dishes rattled. (*Chico Courant*, Oct. 23, 1868.)

*Colusa*. — Slight shock. Not over a dozen people noticed it. (*Colum Sun*.)

*Marysville*. — Shock very light; noticed by a few only. (*Alta California*.)

*Sacramento*. — Pretty heavy shock from southeast to northwest. Plaster cracked.

Lasted 20 to 30 seconds. Water in the river receded, shoaling vessels, and then rose with a rush. (*Sacramento Union*.)

*Knight's Landing.* — "I was running a flour-mill at Knight's Landing in 1868. While the shock was not unusually severe at that place, it did some damage. The gable end of the mill warehouse was thrown down, not by the vibration of the quake, but by a pile of wheat being thrown down against it and forcing the end of the building out. I was out in a pasture at the time, pumping water for stock, and noting the water sloshing from one end of the trough to the other, I wondered as to the cause, as I had not felt the shock on account of the motion of my body in working the pump. On looking up I noticed the trees swaying back and forth, with no wind, and I knew it must be an earthquake. There was some little loss in the town in the way of broken crockery, chimneys, etc. The heaviest shock was along the edge of the valley near the Coast Ranges. In this county it was heaviest at Winters, where it demolisht John Wolf-skill's house, a stone building, and did considerable other damage." (E. H. Eastham.)

*Woodland.* — Two severe shocks, from southeast to northwest, lasting a minute. (*Alia California*, Oct. 22, 1868.)

*Suisun.* — Severe shock, north and south. Slight damage. A few brick buildings cracked. (*Solano Sentinel*, Oct. 22, 1868.)

*Solano.* — Severest shock ever felt. Sudden upheaval, attended and followed for nearly a minute by a swaying in a north and south direction. No damage except cracks in walls. (*Sacramento Daily Union*, Oct. 24, 1868.)

*Martinez.* — Some buildings damaged by cracks. Waters in front of town caused to dance. Fish rose to surface. (*Martinez Gazette*.) Court-house wrecked. (Holden.)

*Walnut Springs.* — Heaviest shock ever felt. Goods in store thrown from shelves. (*Alia California*, Oct. 22, 1868.)

*Antioch.* — Severe shock from southwest to northeast for 30 seconds. Several fissures formed in the ground. (*Sacramento Daily Union*, Oct. 23, 1868.)

*Benecia.* — At the repairing works of the Pacific Mail Steamship Company, an iron shaft of one of the side-wheel steamers was lying on the ground in a north-south direction. The earth moved from under it 9 inches, lengthwise, but in what direction is not recorded. (George Davidson.)

*Stockton.* — "I was then 13 years old. With a younger brother and a third boy I had, on the morning of October 21, 1868, gone to the edge of the tule marsh about 2 miles southwest of Stockton, to shoot ducks. Thn morning flight of birds was over, and we were returning home. My brother had his gun at the shoulder and was aiming at a meadow-lark when the earth movement commenced. The lark flew up without apparent cause, the gun moved up and down slightly, and I at once had a feeling that something unusual was happening. Within a few seconds the water-fowl, hidden from us by the tule but in countless numbers, rose with a noise like rolling thunder and took flight toward the west; while 0.5 mile to the east a small band of cattle, with heads down ami tails in the air, were racing across the country. By this time the earthquake was probably at its maximum, and, looking east, I could distinctly see the ground's surface in wave-motion, the waves apparently moving across the line of vision. During the time this motion continued, it was not perceptible as a vibration to the sense of feel-ins. All three of us admitted, however, that the earth felt insecure underfoot. We could detect no effect, on the water surface of the swamp. Stockton escaped with only herr and there a cracked brick wall." (C. E. Grunsky.)

Most severe shock ever felt. Vibration from northwest to southeast. West of Lodi and Woodbridge, shock was as severe as in Stockton. (*Stockton Independent*.)

In a slough water was thrown into ebullition to a height of 2 feet for a few minutes. (*Stockton Gazette*.)

*Berkeley.* — The State Institution for the Deaf, Dumb, and Blind lost 11 chimneys and 2 gables, and rear walls were cracked in several places. (*Oakland News*, Oct. 21, 1868.)

*Oakland.* — Shock preceded by a rumbling sound. Pans of milk and tubs of water emptied almost in a moment; trees whipt about like straws; many houses twisted 5 or 6 inches out of square, particularly those on brick foundations. The crashing of falling brick at the Deaf, Dumb, and Blind Institute was heard a few blocks to the south before the shock was felt. Chimneys very generally down, particularly those on south and east sides; in some parts all chimneys thrown. Many chimneys twisted, if not thrown. Many brick buildings were shattered, and several wharves went down with loads of brick, coal, hay, etc. In Brooklyn, as in Oakland, many chimneys were broken off at the roofs. (*Alia California*, Oct. 22, 1868.)

The drawbridge of the San Francisco and Oakland Railway was thrown out of place about 8 inches. (*Centennial Book of Alameda County*, p. 266.)

Thruout the city chimneys and walls fell south. (*Oakland News*.)

Of two houses next each other the older one stood on posts 4 feet above the ground, while the other was supposed to be earthquake proof. The basement walls were solid and of good workmanship. The old house was badly shaken, but not injured; the earthquake-proof house had the basement walls cracked, all the ceilings thrown down, and the marble mantel in each of the rooms thrown upon the floor. (Geo. Davidson.)

*Alameda.* — Shock very severe. Scarcely a house escaped uninjured. (*Alia California*, Oct. 23, 1868.)

*San Leandro.* — The earthquake was much more severe than in Oakland or Alameda. Not a building escaped some injury. Chimneys fell north and south. The court-house was in ruins. A tank 10 feet wide and 6 feet deep was entirely emptied of water. The bed of San Leandro Creek<sub>3</sub> which had been dry for several months, became filled with a stream of water 6 feet wide and a foot deep. A team of mules descending a hill 9 miles east of Haywards, were thrown to their knees. A rumble preceded the shock. The rangers on the old Peralta rancho said the crack past through the foot-hills on to Oakland. (Various old residents.)

*San Lorenzo.* — The limbs of a sycamore tree, 24 feet high, struck the ground. (G. Hyde.)

Flat irons and a kettle were jerked off the stove southward. (Mrs. Adams.)

House and bam were both prostrated. (Mrs. E. H. Gansberger.)

A house was thrown off its foundations. Chimneys were thrown northward. (E. Llewellyn.)

*Haywards.* — The crack past diagonally up the Haywards Hill and crest 3 feet from the south corner of the old hotel; past just east of the Odd Fellows' Building, through the Castro lot, tearing off a corner of the adobe house which stood where the jail now is, on through Walpert's Hill toward Decoto. By the hotel the crack first opened 18 to 20 inches, but soon closed to 5 or 6. It was of unknown depth; several balls of twine, tied together, with an iron sinker, failed to find bottom. There was no water in the fissure, for the iron came up dry. From the corner of B and First Streets another crack past nearly eastward toward the hills, and faded out by the sulfur spring about 1.5 miles distant. (Mrs. Wm. Haywards.) In a general way, the crack from Haywards to beyond Decoto past from 100 to 300 feet above the base of the hills. Practically not a house was left on its foundations in Haywards. At one place south of town the fault showed a throw of some 3 feet. (W. H. Weilbye.)

"Since October 5, 1862, I have lived in Haywards, Alameda County, and I well remember the earthquake of October, 1868. Being lame and having used a cane from childhood, I had never walked without it until that morning. I was working in my shop at the time. On feeling the terrible shock, and on the impute of the moment, I managed to

get out of the building and into the street, some 18 feet distant, but on recovering from my fright I found I had left my cane in the shop. I managed to get back into the building, got my cane, and started for my house only a few yards away. The house had been thrown from its foundations, the chimney had been torn from the roof, and the porch had been wrenched away. Dishes were broken and everything was in confusion. I discovered that most of the houses were in the same condition as my own — thrown from their foundations, with chimneys down, porches knocked sideways, etc. All the while the ground was shaking and continued to shake for days and even weeks; but each shock was lighter than the last. On a certain piece of ground near the Haywards Hotel there was a common board fence, the boards abutting on the post. After the quake the boards lapt one over the other about 5 inches, the ground seeming to have been prest together that much. On going down the county road toward Oakland, we came to Mr. A. L. Rockwood's house, which had been thrown from its foundation and one end thrown into the cellar. The house was badly wrecked. In the south part of the town there was a flour mill on a foundation about 4 feet high. This building was thrown to the ground and wrecked. On the ground which is now the plaza stood a new brick warehouse filled with grain from the season's crop. The building was completely torn to pieces; grain was spilt from the sacks, and everything was in a mess. The building was 300 feet long by about 60 feet wide. A wooden warehouse about the same size shared the same fate as the brick. On B Street the ground opened about 2 inches, and water and sand were forced from the opening. Some springs were closed, while others were opened or made to flow more freely. Many wells were affected in the same manner. Mr. Charles Herman, who was in the baking business, was driving back to Haywards after delivering bread. Looking up the road, he saw the ground coming toward him in waves, and when the motion struck his horse, she went down on her knees. Mr. Herman thought the world had come to an end. As he neared the San Lorenzo Creek, he noticed that the water had been thrown out of the bed of the creek on to the road.

" At San Leandro the earthquake destroyed the brick court-house, which was then located there. A Mr. Joslyn was killed in attempting to escape from the building. Many buildings were much damaged in that town as well as in Haywards. The earthquake was the direct cause of the death of 2 persons in Haywards." (George A. Goodell.)

The crack past thru a gravel quarry practically on the summit of the first range of hills. (O. Hill.)

The crack below Haywards Hotel was 12 inches wide. It ejected water and white sand. A fence which traversed a hill from north to south was crosst by the crack, and had the ends of the boards loosened from the posts. Gradually these boards lapt over one another, until within a couple of weeks they overlapt several inches, the progress of the overlapping being noted from time to time by a pencil mark. The "cap" board of the fence was also arched up in consequence of this movement. Large waves were set up in the soil. The house was moved southward, while a neighbor's was tipt northward. (D. S. Malley.)

The rumbling preceding the shock came very distinctly from the bay, and the plain in that direction rolled like huge waves of the sea coming toward Haywards. (F. Allen.)

The crack opened parallel to Castro Street, 35 to 50 feet below Haywards Hotel. The fence passing diagonally up the hill was shortened 6 inches. (P. McKeever.)

A stove in the house was thrown north. (J. Wolput.)

A crack 3 to 4 inches wide started from the Powell place and struck across toward the county bridge next to Nettleton's, passing west of it; crosst the creek, demolisht a fence completely, and past on toward the Strowbridge residence, where the house was badly shattered. (Mrs. Hamer.)

The shock was from southwest to northeast. The ground opened from 6 inches to 2 feet, and water with sand was ejected to a height of from 1 to 3 feet. North of the village a ridge of ground 3 feet wide was raised 2 feet. By the time the shock was over, nearly the whole place was in ruins. Near Hayward's Hotel the hill shifted a good deal, and a crack opened for several hundred feet. On the hills there were several new springs. In the first 12 hours after the main shock there were 36 after-shocks. Between Haywards and Mission San Jose there were numerous cracks, so that it was difficult to drive a stage between the two towns. (*Alto California*, Oct. 22-25, 1868.)

*Mt. Eden.* — All the shelving on south side of the 2 stores of the town was thrown down. (*AIM California*, Oct. 22, 1868.)

*Alvarado.* — Shocks were violent. The ground opened in several places and water issued. (*Alia California*, Oct. 22, 1868.)

*Centerville.* — A dwelling-house was partly destroyed and 2 stores were wrecked. Hotel settled 2 feet. (*Alta California*, Oct. 22, 1868.)

*Roberts' Landing.* — "Our house broke in three pieces, each part falling outward. A boiler of hot water was on the stove, and with the first deafening jolt, the hot water came my way; giving me a bath I have never forgotten. Horses fell to the ground and men clung to some quince trees near.

"Captain Petersen, of the steamer San Lorenzo, who is now deceased, was walking along the road to Roberts' Landing when he heard a great rumble off across the fields toward San Leandro. He looked quickly in that direction, and over a mile away could see the great wave rapidly approaching. He rushed to the side of the road and had caught hold of the fence by the time the shock broke. Near him on the road a 6-mule team was drawing a load of grain, and all the mules fell flat and could not regain their feet until the great jolt was over. During the 3 or 4 succeeding days there were 150 shocks; none, of course, with anywhere near the extent of the heavy one." (R. C. Vose.)

*Decoto.* — Opposite Decoto a crack appeared about one-third of the way up the slope. It opened 10 or 12 inches at the surface and faulted about as much on the plains side. The level lands waved like the ocean, and the waves seemed to approach from the south. (Mr. Decoto.)

*Tyson Lagoon, south of Niles.*—A tank swayed north, then south, and fell. The lagoon parted lengthwise down the middle and threw water and mud both ways. After the earthquake the lagoon was dry for 3 years. It has no outlet. Rumbblings preceded the main shock and many of the after-shocks. (Mrs. Wm. Tyson.)

A crack went thru the old Shinn place, crossed the Centerville-Niles road about 0.6 mile southwest of the Southern Pacific Railway track, and past thru the Tyson Lagoon. (H. Tyson.)

*Niles.* — The water from the tank sloped nearly east. Rumbblings preceded the after-shocks. These were more severe than in April, 1906. (C. Overacher.)

A crack past thru the Shinn and Tyson places. (C. Bonner.)

*Irvington.* — Thru the north side of town a crack split the hillside, opening 7 or 8 inches and showing a fault of 8 or 10 inches. It crossed the country road  $\frac{1}{2}$  mile north of the Southern Pacific Railway depot. Its trend was N.  $45^{\circ}$  to  $50^{\circ}$  W. From three low hills the crack seemed to pass over into the tule ponds north of town. The Tyson Lagoon dried up after the quake. The rumbling preceding the shock came from the north. (R. B. Crowell.)

The railroad tracks north of the station were badly twisted for several hundred y.wk (M. Torry.)

In one place the crack on the hillside divided, and formed a narrow band, 8 or 10 feet across, which dropped below the general level of the water 8 or 10 inches. Springs were opened up on Mission Peak. (H. Crowell.) The crack which part thru the town  $\frac{1}{2}$  mile

tinued southward down the hillside about 0.5 mile northeast of the railway track. It opened 5 to 8 inches, not faulting.

"I was then about 15 years of age. My home was near Irvington. When the shock came, I was alone in the house with my baby brother. My mother was in the milk house, about 10 steps from the kitchen door. She called to me to get the baby. Tho I was thrown the length of the dining-room, I managed to get the child over my arm, face down, and a pillow on top. Then, falling and crawling, I worked my way back to the open kitchen door. My mother was on the ground. Every time she tried to get up, she was thrown again, and the milk in the buckets was spilt over her. My two brothers, my step-father, and the hired man were also down and were trying to get to the house by crawling and falling. As I sat there, I could see the ground in waves like the ocean. After the main shock, I think we had 100 shocks during the first 24 hours. The ground opened; we traced a crack thru town, and the ground settled several inches in one place. Not a house was left with a chimney on it. Our safe broke thru the floor, and the piano was out in the room nearly to the opposite side." (J. McD. Preston.)

*Mission San Jose.* — "I was curled up in a big rocking-chair, reading, and my two sisters were outside playing, when suddenly there came a swaying of the house. This lasted only a short time; then the house began to shake in earnest. My sisters began to cry and scream. I jumped out of the chair to go to them, and ran from the room, bumping against both sides of two doors. I finally reached the porch and succeeded in catching hold of a post. I distinctly remember that the pump in the yard was pumping as if some one had hold of it; and small rocks on the hill in front of the house were rolling down into the creek. The milk pans had been resting on shelves of slats; some pans slipt entirely out, some only halfway. The milk and cream were on the floor. My brother was hauling a load of wheat to San Jose. When the earthquake was at its worst, he thought his team was choking down and jumped off his wagon to find he could hardly stand. I was told at the time that the water spurted up in the streets of San Jose, and out in the road between Milpitas and San Jose, to the height of several feet. The old Mission church, which was of adobe, was shaken down, as were several other buildings at the same place. On the mountain above the old Mission, just above a place called Peacock Springs, a great crack in the earth appeared, which lookt as if the lower part of the mountain had parted and slipt down. Many times I have crost the bridge which was built over the crack, and stopt and thrown rocks down to see if I could tell how deep it was." (Mrs. N. Ainsworth.)

Along the hills back of the town and southward, passing thru the present Sinclair and Stanford ranches, the crack opened. Generally it was 10 or 12 inches wide, and faulted some 18 inches on the valley side. (A. Kell.)

The shock was preceded by a rumble passing to the northwest. Adobe building not seriously injured. Crack at Irvington and on the side of Mission Peak confirmed. (J. Sunderer.)

Brick store was cracked. Confirms cracks at Irvington. (S. Ehrman.)

Chimneys fell north and south, as they did also on April 18, 1906. (S. Murphy.)

*Warm Springs.* — The crack past along the foot-hills at an elevation of 350 to 450 feet from Niles southward, back of Mission San Jose, disappearing near the county line. In some places the fissure showed a fault of 10 to 12 inches. (H. Curtner.)

The warehouse and wharf on the slough fell, also Dixon's house. Cracks in the vicinity of Milpitas flowed artesian water for 48 hours after the shock. (Mr. Durkee.)

*Milpitas.* — Along Coyote Creek the ground was cracked from Boot's ranch to the San Francisco Bay, the cracks being on the bay side and following the winding of the creek. As in 1906 much water was ejected from the cracks, and Coyote Creek rose. (W. Bellou.)

*Calaveras Valley.* — Only one or two chimneys were dislocated. (J. Patton.)

*Santa Clara County.* — Messrs. J. W. Hines and C. Valpey, and Miss Bennett, of San Jose; Mr. H. B. Valpey, of Santa Clara; Messrs. P. Anderson and C. B. Mendor and Mrs. W. Smith, of Berryessa, all of whom were intimately acquainted with this section of the country in 1868, report that there was no crack south of the county line.

*Alcatraz Island.* — A rumbling sound accompanied the shock, and the island vibrated with a jerking motion. (Dr. L. Hubbard, U. S. A., in *San Francisco Times*, Oct. 22, 1868.)

*Colma.* — "I was then 16 years of age and lived in San Mateo County, a mile or so south of the present town of Colma. With my father I was digging and sacking potatoes in a field. I was sewing up a sack, when my father said: 'Look at that mountain. What is the matter with it?' We felt no earthquake, but the mountain seemed to be bobbing up and down. A freight train was going north along the S. P. track. Shortly after we had observed the mountain apparently moving, the earthquake reached the railroad track and the freight train appeared to gyrate like a snake. The next instant we felt it. The shock was very severe, throwing us to the ground and knocking over sacks of potatoes. A band of loose horses, including a lot of young stock, in an adjoining field, ran around the field at great speed, utterly panic-stricken. The house we lived in was in a flat some 0.5 mile from where we were at work. When we reached it, we found that milk pans in the pantry had been entirely emptied of their contents. Some panes of glass were broken and some crockery and glassware were thrown down and destroyed; but the house, a light frame building, was not injured. There were 48 shocks between the first one and midnight that night.

"I do not now recall any serious damage done in San Mateo County. There were some landslides occasioned along precipitous hills and creek banks, but the buildings in that section were all frame, and none of them were destroyed to my knowledge." (J. A. Graves.)

*San Mateo.* — Vibrations from the north for 15 seconds. (*Alia California.*)

*Redwood City.* — The court-house was wrecked and other buildings were damaged. The shock seemed to come from the southeast and lasted 30 seconds. (*Redwood Gazette*, Oct. 24, 1868.)

*Mountain View.* — Severest earthquake yet felt. Far worse than that of 1865. Shock from northwest to southeast. (*Alia California*, Oct. 23, 1868.)

*Santa Clara.* — Severe shock. Motion northeast to southwest. No serious damage. (*Aha California*, Oct. 22, 1868.)

*San Jose.* — "The most terrible earth shock ever experienced in this section since the settlement of this country by Americans, occurred yesterday morning at 8 o'clock. A dense fog hung over the city at the time, when, with scarcely a premonitory tremor, the shock was upon us in all its force. Buildings and trees seemed to pitch about like ships in a storm at sea. Fire walls and chimneys were thrown down in all parts of the city. The heavy brick cornice of Murphy's building at the corner of Market and Eldorado Streets fell to the ground. The Presbyterian Church has sustained an immense damage. The brick turrets are all down, and large portions of the steeple were precipitated thru the roof to the floor, crushing the organ and causing great damage to the gallery and fixtures below. The walls of the steeple are almost a total wreck and will have to be taken down. \$5,000 would not make good the damage done to the church. The large water-tank on the roof of Moody's flour mill fell thru the roof, carrying destruction in its course. Their wooden store-house, 100 feet in length, filled with grain, is a total wreck and the grain badly mixed. Two huge chimneys of the San Joaquin Institute were thrown down, one of them crushing thru into the rooms below. A portion of the rear wall of Welch's livery stable fell. Otter's unfinished block at the corner of Fifth and St. John Streets, sustained a very serious damage. There is not a brick building



in the city that is not more or less injured. Brick walls are everywhere wrenched and cracked and many of them are ready to fall. Another such shock would precipitate many of our brick buildings to the ground. The brick cornice of the Masonic Hall Building will have to be taken down, and the entire building, in its present condition, is decidedly unsafe for occupancy. A large quantity of crockery and glassware was broken. The destruction of plate-glass windows is very great, and much havoc is done to plastering generally. The new court-house stood the shock admirably. Some little crumbling of plaster decoration is all the damage it sustained. The lesson of the earth shock is: Erect no more high church steeples, and build no more brick buildings above 2 stories in height, and those only in the most substantial manner. A second but much lighter shock was experienced at about 10<sup>h</sup> 30<sup>m</sup> of the same day, and shortly thereafter a third shock of like character." (*San Jose Mercury*, Oct. 22, 1868.)

Where the Milpitas road crosses Coyote River, the banks were shaken together and the river-bed filled up. (*San Jose Argus*, Oct. 24, 1868.)

*Old Gilroy.*—The building shook and rocked till the occupants became seasick. The oscillation seemed to be southwest and northeast, and lasted about 30 seconds. No damage was done beyond some broken bottles in the drug store. (*Gilroy Advocate*, Oct. 24, 1868.)

Rumble preceding the shock came from the north. Chimneys fell north and south. It was fully as heavy as the shock of 1906, but not so long. The old adobe buildings were much damaged. (W. D. Dexter.)

The shock was not so severe as in 1906. (Messrs. Rice, C. Wantz, Bryant, Gilman.)

*Pacheco.*—Every brick house in town was ruined. (*Alia California*, Oct. 22, 1868.)

*San Juan.*—The shock was the heaviest since 1865. Lasted 30 seconds. (*Alta California*, Oct. 22, 1868.) No chimneys fell; 2 brick walls were cracked. (C. Bigley.)

*Santa Cruz.*—Severe shock from east to west, preceded by rumbling noise. Lasted 15 seconds. Several brick buildings badly cracked. (*Alta California*, Oct. 22, 1868.) Second only to the earthquake of 1865. Vibration from northeast to southwest for 30 to 40 seconds.

At Watsonville chimneys and plastering suffered but little. At Eagle Glen a slide 50 feet wide carried rocks and trees 1,000 feet. In Soquel a few chimneys were dislocated.

*Half Moon Bay to Pescadero.*—Chimneys down or twisted, along the coast. (T. G. Phelps, Holden's report.)

Near Pescadero limbs fell from the redwoods and large pieces of rock rolled down the mountains. (*Grass Valley Union*, Oct. 29, 1868.)

*Monterey.*—A smart little earthquake, traveling from north to south. No particular damage. (*Monterey Gazette*.)

*Downieville.*—A slight earthquake was felt. (*Mountain Messenger*, Oct. 24, 1868.)

*Grass Valley.*—Lamps vibrated. Vibrations from southwest to northeast. (*Alta California*, Oct. 22-24, 1868.)

*Nevada City.*—Three distinct shocks felt. Also felt at You Bet. (*Nevada Transcript*.)

*Placerville.*—Shock plainly felt. (*Mountain Democrat*, Oct. 24, 1868.)

*Amador County.*—The earthquake was distinctly felt at Pine Grove and Volcano. (*Alia California*, Oct. 25, 1868.)

*Jackson.*—Earthquake perceptible to a number of people. (*Amador Dispatch*, Oct. 24, 1868.)

*Folsom.*—A slight shock. Clocks stopt. (*Folsom Telegraph*, Oct. 24, 1868.)

*Sorwm.*—A slight shock. (*Alta California*, Oct. 22, 1868.)

*Tuolumne.*—Shock lasted 10 to 15 seconds. Severe. (*Tuolumne City News*, Oct. 23, 1868.)

*Snelling.* — Hard shock. No damage. (*Merced Herald*, Oct. 24, 1868.)

*Visalia.* — Shock felt by few persons. (*The Delta*, Oct. 28, 1868.)

*Nevada.* — At Gold Hill and Carson, shock perceptible to people awake, and a few people awakened. (*Territorial Enterprise*, Oct. 22, 1868.)

The shock was apparently not felt in TJKiah, Yreka, San Luis Obispo, Los Angeles, Reno, Virginia City, Alpine County, Yuba County, Trinity County, or Oregon.

## SUMMARY.

A review of the facts above presented regarding the earthquake of 1868 makes the following summary statement possible:

1. The earthquake of 1868, like that of 1906, was due to an earth-movement on a rupture plane or shear zone which was manifest at the surface as a fault-trace.

2. The fault on which the movement took place was quite distinct from the San Andreas fault.

3. It parallels the latter at a distance of about 18.5 miles to the northeast.

4. Like the San Andreas fault, it is coincident with an old diastrophic line upon which similar movements have been recurrent in time past.

5. The old diastrophic line is marked by a degraded fault-scarp, which bounds the valley of San Francisco Bay and Santa Clara Valley on the northeast.

6. Along this line there are certain geomorphic features analogous to those which characterize the San Andreas Rift.

7. The fault-trace of the fault of 1868 was much shorter than that of 1906, having a known length of only 20 miles.

8. The amount of horizontal movement, if any, was much less than on the San Andreas fault in 1906, and its direction is unknown.

9. The vertical movement appears from the accounts given to have been small also, and to have been manifest as a downthrow on the southwest or bay side, altho this is not satisfactorily established.

10. The fault-trace was characterized for the most part by a crack which in places, particularly on the lower ground, was superficially gaping. Associated with this main crack there were auxiliary branching cracks; and on the alluvial bottom-lands about San Francisco Bay there were numerous secondary cracks which were usually not discriminated by the observers of that day from the fault-trace.

11. In harmony with the shortness of the fault-trace and the small movement apparent along it, the area of destructive effect was much smaller than in the case of the earthquake of 1906. This was true also of the entire area embraced by the isoseismal II R. F. While the data are insufficient for plotting the isoseismals satisfactorily, it is nevertheless clear that these curves plotted as ellipses on the map of California would have had much shorter major axes than in the case of the isoseismals for the earthquake of 1906; while the minor axes in a northeast-southwest direction would not differ greatly for the two earthquakes. We have no authentic reports of the earthquake north of Chico nor south of Monterey, altho perceptible tremors probably did extend further south. On the other hand, in a direction normal to the fault-trace the earth-wave made itself felt as far as the State of Nevada.

12. The intensity was X in the vicinity of the fault-trace at Hayw&rds.

13. In San Francisco the chief damage caused by the earthquake was, as in 1906, on the made land and along the margin of the old shore and marsh border. But little damage was sustained by structures on the rocky slopes.

14. The foot of Market Street, San Francisco, is about midway between the San Andreas Rift and the fault-scarp upon which movement occurred in 1868. The city

has, therefore, to reckon with the latter as well as the former in its future career, and consequently should be doubly prudent in the location and structure of its important buildings.

15. The cities on the east side of San Francisco Bay are less concerned with the San Andreas Rift, but are more immediately affected by the proximity of the diastrophic line marked by the front of the range of the Berkeley Hills.

16. The interval between the disastrous movement of 1857 on the San Andreas Rift and the movement on the Haywards fault in 1868 was 11 years.

#### THE EARTHQUAKE OF 1865.

About 12<sup>h</sup> 45<sup>m</sup> r. M., on October 8, 1865, a moderately severe earthquake shook middle California. Most of our information regarding it is assembled in Holden's Catalogue of Earthquakes. In the *Sacramento Daily Union* of that date it is described as the most violent ever experienced there. After several vibrations a second or two intervened, and the shaking was then repeated more violently than at first. The vibrations seemed to be east and west, but a few peoples thought they were from southwest to northeast. Clocks stopt, and there was a general feeling of dizziness and nausea. The same paper states that at Stockton the shock was heavy and seemed to pass from north to south, but that no damage was done. At Petaluma there were two severe shocks in quick succession, vibrating from northwest to southeast. The shock was the heaviest experienced up to that time. All brick buildings were more or less injured. The first shock was from the northwest to the southeast, followed by a general shaking or rolling, closing with a jerk. At San Jose the shock was very severe. Brick walls fell and the convent bell tolled. At New Almaden a large brick store-house on the hill was nearly demolisht. Several houses in the village were thrown down. The earth opened and closed again. Chimneys in different parts of the county were thrown down. (*San Francisco Bulletin*, Oct. 12, 1865.)

At Watsonville there was a heavy shock. The earth opened in several places (secondary cracks), throwing up water. At Santa Cruz the shock was apparently heavier than elsewhere. Every brick building was reported ruined. The motion was apparently east and west. The lowlands along the river opened and spouted water like geysers. Some wells went dry or were filled with sand. The tide rose very high at the time of the shock and fell very low immediately afterwards. (*Bulletin*, Oct. 9, 1865.)

"Monterey escaped unharmed." (*Sacramento Daily Union*, Oct. 9, 1865.)

After shocks were reported at San Jose, Santa Clara, and Santa Cruz.

There is no record of the shock having been felt at Marysville, Yreka, Eureka, or in Alpine County; the *Mountain Messenger* of October 14, 1865, states that it was not felt at Visalia nor in Los Angeles. The *Bulletin* of October 17, 1865, states that it was not felt in Santa Barbara.

In San Francisco, according to the *Bulletin* of the date of the earthquake, there was a violent shock lasting about 5 seconds, followed almost instantly by another much heavier shock, which continued for 10 seconds or more. Vibrations appeared to be nearly east and west, but some experienced observers said that the movement was in the same direction as previous shocks — nearly northeast and southwest. The commencement of the shock was accompanied by a rumbling sound. During the following evening there were two or three slight after-shocks. The effects of the earthquake were visible in every street. No buildings were entirely demolisht, but the damage aggregated many thousands of dollars. The most important damage to buildings occurred at the following localities:

<p>Corner Mission and Third Streets. Upper half of front of 4-story brick building fell; poorly constructed.</p> <p>Northeast corner Battery and Washington Streets. Old Merchants' Exchange ruined.</p> <p>Beale Street, near Market.</p> <p>Kearney Street, near Sutter.</p> <p>Jackson Street and Stout Alley.</p> <p>Mission and Fremont Streets.</p> <p>Battery and Union Streets.</p>	<p>Corner Kearney and Washington Streets, City Hall had front wall badly cracked and entire building rendered unsafe.</p> <p>Washington Street, near Sansome.</p> <p>Market Street, near Sansome.</p> <p>Pine Street and Front Street.</p> <p>Market and Pine Streets.</p> <p>Sacramento and Battery Streets.</p> <p>Sacramento and Webb Streets.</p>
---	---

On the marshy lands in the vicinity of Howard and Seventh Streets the ground was heaved in some places and sank in others. Lamp-posts were thrown out of perpendicular, gas-pipes were broken, etc.

It appears probable from these scant records that the seat of the earthquake of 1865 was somewhere in the Santa Cruz Mountains, between San Jose and Santa Cruz. If this conclusion be accepted, it seems further probable, in the light of recent events, that it was due to a minor movement along the San Andreas Rift. It was probably a somewhat less severe earthquake than that of 1868. The earth movement which gave rise to the shock extended neither so far south as in 1857 nor so far north as in 1906, but appears to have pertained to that portion of the Rift affected in 1906 rather than to that affected in 1857.

The only other earthquake which can definitely be referred to a movement along the San Andreas Rift was that of April 24, 1890, which, according to Messrs. F. Abby and Charles Bigley, of San Juan, opened a fissure at that place on the line of the Rift. The railway bridge at Chittenden was displaced, as it was in 1906.

#### THE EARTHQUAKE OF 1857.

Information regarding the earthquake of 1857 is scant and generally unsatisfactory as to details. California at that date was very sparsely populated, particularly in the southern Coast Ranges, where the seat of the disturbance was. The only records that have come down to us are those of Trask, in the Proceedings of the California Academy of Sciences, Vol. 1, 1873; a note by J.S. Hittel in his "Resources of California," 1863, p. 42, and some notes in Holden's Catalogue of Earthquakes. These brief notes are supplemented by the statements of a few old residents who recall the event, some of whom were in the zone of acute disturbance at the time. The data, while insufficient for a satisfactory account of the earthquake, warrant the statement that it was due to a displacement or fault in the San Andreas Rift, along its extent from Cholame Valley to the San Bernardino Valley, a distance of about 225 miles.

According to Dr. Fairbanks, who has recently been over the course of the Rift in the southern Coast Ranges, the residents along that line have either very vivid recollection or very strong tradition regarding the rupturing of the ground at the time of the earthquake; and Dr. Fairbanks' field observations confirm the probable truth of their statements. It appears to have been generally recognized by people familiar with the southern Coast Ranges that the shock was due to or associated with the rupture of the ground, and the line of rupture is commonly referred to by the country people as the "earthquake crack." This crack, as opened in 1857, with differential displacement of unknown extent and direction, is still pointed out as a remarkable phenomenon from Cholame Valley southeastward along the northeast side of the Carissa Plain, through the Tejon Pass, thence along the southwest side of the Mojave Desert, past Lake Elizabeth and Palmdale, to the Cajon Pass and thence to the south side of the San Bernardino Range. The shock was felt from Fort Yuma to Sacramento, and the total area sensibly affected was probably not much less than in the earthquake of 1900. It was severe both at Los Angeles and San Francisco. At Los Angeles shocks continued at intervals during the

day. Mr. H. D. Barrows, who was in that city on the day of the earthquake, in a letter dated August 5, 1906, communicates the following information as to his experiences:

The great earthquake of January 9, 1857, in southern California, opened the ground for nearly 40 miles in a straight line near Elizabeth Lake. I had a brief account of it in the *San Francisco Bulletin* about February 1, 1857 — my letter (signed "Observador") being dated January 28, 1857.

Only one life was lost by that great convulsion of nature, a woman being killed at Fort Tejon by the falling of adobe walls; and, considering the colossal disturbance, very little damage was done to buildings here in Los Angeles. This is probably accounted for by the fact that our buildings were of only one story, with walls 2.5 and 3 feet thick. At the time of the great upheaval, I was in the yard at the south side of the adobe house of William Wolfskill, the pioneer, near the present site of the Arcade Depot in Los Angeles. I first stumbled toward the west, and was almost thrown down; then, after a brief period, I commenced to stumble in the opposite direction. Other persons near me stumbled in similar fashion. The long wide corridor on the south side of the Wolfskill house was hung with grapes, and I noticed that they swung back and forth clear up to the rafters. Water in tanks was thrown out in numerous instances, clocks were stopt, etc. The movement seemed to be comparatively slow, giving things time to recover after moving in one direction. If the motion had been short and sudden, the damage would have been appalling.<sup>1</sup>

All the houses in Santa Barbara were damaged by the shock of 11<sup>h</sup> 20<sup>m</sup> P.M., January 8. (Perry, Holden's Catalogue.)

At Visalia it was difficult to stand erect; treetops waved several feet to and fro; it was equally severe at places within 50 miles north and south. There were several shocks felt at Stockton and Benson's Ferry, and the principal one was very severe at Sacramento, Los Angeles, and Monterey. (*San Francisco Bulletin*, Jan. 9, 1857.)

At San Francisco the main shock was preceded by 4 slight shocks at 11<sup>h</sup> 20<sup>m</sup> p. M., January 8; 11<sup>h</sup> 33<sup>m</sup>, 4<sup>h</sup> 15<sup>m</sup>, and 7<sup>h</sup> A. M., January 9. The main shock stopt a jeweler's clock at 8<sup>h</sup> 13<sup>m</sup> 30<sup>s</sup> A. M. Prof. George Davidson, who was in the city at the time, says the shock was sudden and sharp, preceded by no noise. He was lying north and south, and felt the movement in that direction. A friend who was lying east and west was thrown out of bed.

Professor Davidson also contributes the following:

The wholesale grocery store of Goodwin Brothers faced east on Battery or Front Street, with its length of about 100 feet on Commercial Street. It was a 1-story brick structure about 15 feet high, with a flat metallic roof and a fire-wall of 3 or 4 feet above and around the roof. There were no windows nor doors on Commercial Street. The fire wall along Commercial Street was thrown bodily from the main structure into the street. The inner edge of the bricks was a straight line, at a measured distance of 6 feet from the base of the wall, while the general mass was scattered across Commercial Street. In the hardware establishment of Philip T. Southworth, along the west side of the east wall, there was a line of nail kegs, every one exactly 12 inches from the baseboard. Before the shock they had been placed close to the baseboard. These two conditions would indicate a movement of the earth from the northward and westward — roughly, from the north-northwestward. I do not remember damages to other buildings, but am satisfied there were no serious results to property. Among minor details were the effects of the shock upon one of the piled wharves, where a lot of bar-buoys had been left. They had been rolled about in every direction.

The following note on some of the effects of the shock in various parts of the state is extracted from Hittel's "Resources of California," 1863, p. 42:

The waters of the Mokulumne River were thrown upon the bank, almost leaving the bed bare in one place. The current of the Kern River was turned up stream, and the waters ran 4 feet deep over the bank. The water of Lake Tulare was thrown upon its shores, and the Los Angeles River was flung out of its bed. In Santa Clara Valley artesian wells were much

<sup>1</sup> Los Angeles is about 40 miles from the line of the Rift. A. C. L.

affected; some ceased to run, and others had an increased supply of water. Near San Fernando a large stream of water was found running from the mountains, where there had been none before. In San Diego and at San Fernando several houses were thrown down, and at San Buenaventura the roof of the Mission Church fell in. Several new springs were formed near Santa Barbara. In the San Gabriel Valley the earth opened in a gap several miles long, and in one place the river deserted its ancient bed and followed this new opening. In the valley of the Santa Clara River there were large cracks in the earth. A large fissure was made in the western part of the town of San Bernardino. At Fort Tejon the shock threw down nearly all buildings, snapped off large trees close to the ground, and overthrew others, tearing them up by the roots. It also tore the earth apart in a fissure 20 feet wide and 40 miles long, the sides of which went then came together with so much violence that the earth was forced up in a ridge 10 feet wide and several feet high. At Reed's ranch, not far from Fort Tejon, a house was thrown down and a woman in it was killed.

The most interesting fact connected with the earthquake of 1857 is that it was due to an earth movement on the same diastrophic line as that on which faulting occurred on April 18, 1906. The movement in 1857 was, practically speaking, along the southern half of the known extent of the San Andreas Rift, while that of 1906 was along the northern half.



THE CALIFORNIA EARTHQUAKE OF APRIL 18, 1906

---

VOLUME II

THE MECHANICS OF THE EARTHQUAKE



STATE EARTHQUAKE INVESTIGATION COMMISSION

ANDREW C. LAWSON

G. K. GILBERT

H. F. REID

J. C. BRANNER

A. O. LEUSCHNER

GEORGE DAVIDSON

CHARLES BUECKHALTER

W. W. CAMPBELL

# THE CALIFORNIA EARTHQUAKE OF APRIL 18, 1906

---

## REPORT

OF THE

STATE EARTHQUAKE INVESTIGATION COMMISSION

IN TWO VOLUMES AND ATLAS

---

VOLUME II

THE MECHANICS OF THE EARTHQUAKE

BY

HARRY FIELDING REID

---



WASHINGTON, D. C.

PUBLISHED BY THE CARNEGIE INSTITUTION<sup>1</sup> OF WASHINGTON

1910

CABNEGIE INSTITUTION OF WASHING-TON

PUBLICATION NO. 87, VOLUME II

# CONTENTS.

## PART I.

### PHENOMENA OF THE MEGASEISMIC REGION.

	PAGE
THE TIME AND ORIGIN OF THE SHOCK. . . . .	3-15
Descriptions of the Shock. . . . .	3
The Beginning of the Shock. . . . .	5
The Violent Shock. . . . .	9
The Depth of the Focus. . . . .	IX
PERMANENT DISPLACEMENTS OF THE GROUND. . . . .	16-28
The Results of the Surveys. . . . .	13
The Nature of the Forces Acting. . . . .	17
Illustrative Experiments. . . . .	19
The Intensity of the Elastic Stresses. . . . .	20
The Work Done by the Elastic Stresses. . . . .	22
The Distribution of the Deforming Forces. . . . .	22
The Distribution of the Slow Displacements. . . . .	26
A Possible Origin of the Deforming Forces. . . . .	27
ON MASS-MOVEMENTS IN TECTONIC EARTHQUAKES. . . . .	20-82
The Movements before and during Earthquakes. . . . .	20
The Prediction of Earthquakes. . . . .	81
SHEARING MOVEMENTS IN THE FAULT-ZONE. . . . .	83-48
Changes in the Length of Lines. . . . .	38
Cracks in the Ground . . . . .	84
Offsets of Fences and Pipes. . . . .	85
Effects on other Structures. . . . .	87
VIBRATORY MOVEMENTS AND THEIR EFFECTS. . . . .	30-48
Character of the Movements. . . . .	38
Cracks formed in the Ground and the Breaking of Pipes. . . . .	40
Cracks in Walls and Chimneys . . . . .	48
Rotatory Movements and the Rotation of Objects on their Supports. . . . .	43
Surface Waves in the Megaseismic District. . . . .	47
THE INFLUENCE OF THE FOUNDATION ON THE APPARENT INTENSITY. . . . .	49-56
The Greater Damage on Alluvium . . . . .	49
The Theory of Mr. Rogers's Experiments. . . . .	41
Application of the Theory to Small Basins. . . . .	58
Large Basins. . . . .	54
The Foundation Coefficient . . . . .	»

## PART II.

### INSTRUMENTAL RECORDS OF THE EARTHQUAKE.

COLLECTION AND REPRODUCTION OF THE SEISMOGRAMS. . . . .	69
OBSERVATORIES AND THE DATA OBTAINED. . . . .	<del>60-108</del> 62
Berkeley, California . . . . .	62
Oakland, California . . . . .	62

	PAGE
OBSERVATORIES AND THE DATA OBTAINED — <i>Continued</i>	
Yountville, California . . . . .	.62
Alameda, California . . . . .	.63
San Jose, California . . . . .	.63
Los Gatos, California . . . . .	.64
Mount Hamilton, California . . . . .	.64
Carson City, Nevada . . . . .	.65
Victoria, British Columbia . . . . .	.66
Sitka, Alaska . . . . .	.66
Tacubaya, Mexico . . . . .	.67
Cleveland, Ohio . . . . .	.68
Toronto, Canada . . . . .	.68
Honolulu, Hawaiian Islands . . . . .	.68
Ottawa, Canada . . . . .	.69
Washington, District of Columbia . . . . .	.69
Cheltenham, Maryland . . . . .	.70
Baltimore, Maryland . . . . .	.71
Albany, New York . . . . .	.71
Porto Rico (Vieques) West Indies . . . . .	.71
Trinidad, British West Indies . . . . .	.72
Apia, Samoa . . . . .	.72
Mizusawa, Japan . . . . .	.73
Ponta Delgada, Azores . . . . .	.73
Paisley, Scotland . . . . .	.73
Bergen, Norway . . . . .	.74
Eindburgh, Scotland . . . . .	.74
Tokyo, Japan . . . . .	.74
Bidston, England . . . . .	.75
Upsala, Sweden . . . . .	.75
Shide, Isle of Wight, England . . . . .	.76
Osaka, Japan . . . . .	7 6
Kobe, Japan . . . . .	.77
Kew, England . . . . .	.77
Hamburg, Germany . . . . .	.78
Uccle, Belgium . . . . .	.78
Jurjew, Russia . . . . .	.78
Irkutsk, Siberia . . . . .	.79
Potsdam, Germany . . . . .	.81
GSttingen, Germany . . . . .	.81
Coimbra, Portugal . . . . .	.82
Leipzig, Germany . . . . .	.82
Jena, Germany . . . . .	.83
Strassburg, Germany . . . . .	.84
Moscow, Russia . . . . .	.84
Munich, Germany . . . . .	.85
San Fernando, Spain . . . . .	.85
Tortosa, Spain . . . . .	.86
Kremsmiinster, Austria . . . . .	.86
Krakau, Austria . . . . .	.87
Granada, Spain . . . . .	.87
Pavia, Italy . . . . .	.88
Vienna, Austria . . . . .	.89
Said (Brescia), Italy . . . . .	.89
Laibaeh, Austria . . . . .	.90
Triest, Austria . . . . .	.90
Budapest, Hungary . . . . .	.91

CONTENTS.

vii

	PAGE
OBSERVATORIES AND THE DATA OBTAINED — <i>Continued</i>	
O'Gyalla, Hungary.	91
Fiume, Hungary.	92
Florence (Xinaeniano), Italy.	93
Zagreb (Agram), Hungary.	93
Pola, Austria.	94
Quarto-Castello (Florence), Italy.	94
Zi-Ka-Wei, China.	95
Pilar, Argentina.	95
Urbino, Italy.	95
Rocca di Papa, Italy.	96
Belgrade, Servia.	97
Carloforte, Sardinia, Italy.	97
Sarajevo, Bosnia.	97
Ischia, Italy.	98
Caggiano (Salerno), Italy.	99
Taihoku, Formosa, Japan.	99
Sofia, Bulgaria.	100
Messina, Sicily, Italy.	100
Catania, Sicily, Italy.	101
Rio de Janeiro, Brazil.	101
Wellington, New Zealand.	102
Calamate, Greece.	102
Tiflis, Caucasia, Russia.	102
Taschkent, Russian Turkestan.	102
Christchurch, New Zealand.	103
Manila, Philippine Islands.	103
Tadotsu, Japan.	104
Cairo, Egypt.	104
Calcutta, India.	105
Bombay, India.	105
Batavia, Java.	106
Kodaikanal, Madras, India.	106
Perth, Western Australia.	106
Cape of Good Hope, Africa.	107
Island of Mauritius.	107
THE SEISMOGRAM AND ITS ELONGATION	109-114
Earlier Explanations.	109
A New Explanation.	110
The Stronger Transverse Waves.	111
The Separation of the First Two Phases.	111
The Direction of the Motion.	112
The Principal Part and the Tail.	118
THE PROPAGATION OF THE DISTURBANCE	115-114
The Hodographs.	115
The Preliminary Tremors.	117
The Paths of the Waves thru the Earth.	121
Relation of the Velocity to the Depth below the Earth's Surface.	116
Internal Reflections.	128
The Surface Waves.	125
Propagation along the Major Arc.	127
Equality of Velocities along Different Paths.	110
Comparison of the Hodographs of the California Earthquake with other Earthquakes.	180
Determination of the Distance of the Origin of an Earthquake.	182

	PAGE
PERIODS AND AMPLITUDES . . . . .	135-138
During the Preliminary Tremors. . . . .	.135
During the Long Waves and the Principal Part . . . . .	.136
In the Megaseismic District. . . . .	.136
Beyond the Megaseismic District. . . . .	.137
MAGNETOGRAPH RECORDS . . . . .	.139
CONCLUSIONS. . . . .	140-142
Time. . . . .	.140
Undamped Instruments . . . . .	.140
Damped Instruments. . . . .	.141
Period of the Pendulum. . . . .	.141
Magnifying Power for Short Periods. . . . .	.141
Time-scale. . . . .	.142
Identification of the Phases on the Seismograms . . . . .	.142

## APPENDIX.

## THEORY OF THE SEISMOGRAPH.

INTRODUCTION. . . . .	.145
ROTATIONS DUE TO EARTH WAVES . . . . .	.145
FORMS OF SEISMOGRAPHS. . . . .	.147
REGISTRATION. . . . .	.148
THE MATHEMATICAL THEORY. . . . .	.148
THE HORIZONTAL PENDULUM . . . . .	.150
Determination of the Constants. . . . .	.157
Interpretation of the Record. . . . .	.166
Magnification of Harmonic Disturbances. . . . .	.172
Maximum Magnifying Power. . . . .	.175
Suspensions of Horizontal Pendulums. . . . .	.178
THE VERTICAL PENDULUM . . . . .	.179
THE INVERTED PENDULUM. . . . .	.183
SEISMOGRAPHS FOR VERTICAL MOVEMENTS. . . . .	.185
SEPARATION OF LINEAR DISPLACEMENTS AND TILTS . . . . .	.188
DEFINITIONS. . . . .	.191
USEFUL FORMULAE . . . . .	.192

## PLATES.

PLATE	FACING PAGE
1. Map showing Distances and Directions from the Origin of the Shock. . . . .	.59
2. Hodographa of the California Earthquake. . . . .	.114

PART I

PHENOMENA OF THE MEGASEISMIC REGION





# THE CALIFORNIA EARTHQUAKE OF APRIL 18, 1906.

## THE TIME AND ORIGIN OF THE SHOCK.

### DESCRIPTIONS OF THE SHOCK.

The fact that the California earthquake of April 18, 1906, occurred a little after 5 A.M., before people in general were up, is one cause why we have so little reliable information regarding the exact time at which it occurred. In answer to questions sent out by the Earthquake Commission, a very large number of replies were received, but it is quite evident, from the variations among them and from the fact that many only gave the time to minutes, that these times are very unreliable. The general descriptions show that the earthquake began with a fairly strong movement which continued with increasing strength for an interval variously estimated, but which really amounted to about half a minute; then very violent shocks occurred, and quiet was restored about 3 minutes later.

Prof. George Davidson in Lafayette Park, San Francisco, marked time from the beginning of the shock, which he places at 5<sup>h</sup> 12<sup>m</sup> 00<sup>s</sup>. He noticed hard shocks until 5<sup>h</sup> 13<sup>m</sup> 00<sup>s</sup>, a slight decrease to 5<sup>h</sup> 13<sup>m</sup> 30<sup>a</sup>, and quiet again about 5<sup>h</sup> 14<sup>m</sup> 30<sup>v</sup>.

Prof. Alexander McAdie, in charge of the Weather Bureau office at San Francisco, wrote as follows to Professor Lawson under date of September 8, 1907:

I have looked up the record in my note-book made on April 18, 1906, while the earthquake was still perceptible. I find the entry "5<sup>h</sup> 12<sup>m</sup>" and after that "Severe lasted nearly 40 seconds." As I now remember it the portion "severe, etc.," was entered immediately after the shaking.

The time given is according to my watch. On Tuesday, April 17, 1908, my error was "1 minute slow" at noon by time-ball, or time signals which were received in Weather Bureau and with which my watch has been compared for a number of years. The rate of my watch was 5 seconds loss per day; therefore the corrected time of my entry is 5<sup>h</sup> 13<sup>m</sup> 05<sup>s</sup> A. M. This of course is not the beginning of the quake. I would say perhaps that 6 or more seconds may have elapsed between the act of waking, realizing, and looking at the watch and making the entry. I remember distinctly getting the minute-hand's position, previous to the most violent portion of the shock. The end of the shock I did not get exactly, as I was watching the second-hand and the end came several seconds before I fully took in the fact that the motion had ceased. The second-hand was somewhere between 40 and 50 when I realized this. I lost the position of the second-hand because of difficulty in keeping my feet, somewhere around the 20-second mark.

I suppose I ought to say that for twenty years I have timed every earthquake I have felt, and have a record of the Charleston earthquake, made while the motion was still going on. My custom is to sleep with my watch open, note-book open at the date, and pencil ready — also a hand electric torch. These are laid out in regular order — torch, watch, book, and pencil.

Referring to the fact that his time is about a minute later than that given by other observers, he adds:

However, there is one uncertainty; I may have read my watch wrong. I have no reason to think I did; but I know from experiment such things are possible. \* \* \* I have the original entries untouched since the time they were made.

---

<sup>1</sup> The time is given in Pacific standard time, 8 hours slow of Greenwich mean time.

Prof. A. O. Leuschner, director of the Students' Astronomical Observatory of the University of California, Berkeley, gives the following account of the shock as observed by his staff in the neighborhood of the Observatory:

The only reliable record of the commencement of the feeble motion was secured by Dr. S. Albrecht and given by him as 5<sup>h</sup> 12<sup>m</sup> 06<sup>s</sup>, P. S. T. Dr. B. L. Newkirk, on the other hand, was the only observer who took pains to note the last sensible motion, for which he gives 5<sup>h</sup> 13<sup>m</sup> IV. The total duration resulting from these observations is 65 seconds. This is possibly not more than 5 seconds in error.

According to my own observations, the earthquake consisted of two main portions. They are based on counting seconds while carrying my small children out of the house. The earthquake came suddenly and gradually worked up to a maximum, which ceased more abruptly than it commenced. This [first part] lasted for about 40 seconds and was followed by a comparative lull, which was estimated at about 10 seconds. The vibrations then continued with renewed vigor, reaching a greater intensity than before and subsiding after about 25 seconds. According to these estimates the total duration of the disturbance was 75 seconds. It is, however, safe to assume that I counted seconds too rapidly in the excitement of the moment and this duration may easily be 10 seconds too long. The total duration of the sensible motion at Berkeley was probably close to 65 seconds. Dr. Albrecht reports that while he observed several severe shocks, the strongest occurred about 30 to 40 seconds after the beginning.

The mean time clock of the Observatory stopt at 5<sup>h</sup> 13<sup>m</sup> 39<sup>s</sup>, P. S. T.

Prof. T. J. J. See, in charge of the Naval Observatory on Mare Island, San Pablo Bay, reports:

I had been sleeping downstairs, lying with head to an open window, which faced the south, and as the house was not seriously endangered at any time I was favorably situated for making careful observations of the entire disturbance. I had been awake some time before the earthquake began and, as everything was very quiet, easily felt and immediately recognized the beginning of the preliminary tremors. It consisted in an excessively slight movement of the ground, which I compared to the gentle rustling of a leaf in a quiet forest; and then the tremors grew steadily, but somewhat slowly, becoming gradually stronger and stronger, until the powerful shocks began, which became so violent as to excite alarm. Their duration was unexpectedly long, about 40 seconds, according to estimate made at the time, and the subsiding tremors then began. It was just light and I could see the clock face, and I noticed that at the beginning the corrected reading was about 5<sup>h</sup> 11<sup>m</sup>, and at the end about 5<sup>h</sup> 14<sup>m</sup> 30<sup>s</sup>, so that the total duration of the disturbance including the faint tremors was about 3 minutes 30 seconds. The preliminary tremors occupied a little over a minute, the violent shocks about 40 seconds, and the final tremors about a minute and a half.

*The exact time of the phenomenon.* — This was found by the stopping of two of the four astronomical clocks at the Observatory. The violent shocks were so extreme that the pendulums were thrown over the ledges which carry the index for registering the amplitude of the swing. The standard mean time thus automatically recorded was: by the mean time transmitter, 5<sup>h</sup> 12<sup>m</sup> 37<sup>s</sup>; by the sidereal clock, 5<sup>h</sup> 12<sup>m</sup> 35<sup>s</sup>. The yard clock at the gate, which is simply an office clock, though electrically corrected from the Observatory daily, and therefore approximately correct, gave the time as 5<sup>h</sup> 12<sup>m</sup> 33<sup>s</sup>. The agreement of all these clocks is very good; but I think the best time is the mean of the two astronomical clocks, viz.: 5\* 12<sup>m</sup> 36<sup>s</sup>. I estimate that the error of this time will not exceed about 1 second. It must be remembered that the preliminary tremors before the violent shocks began would tend to derange the motions of the pendulums, and they might separate, tho the effect would probably be slight, because the tremors were not violent. It is probable that both pendulums were hung up at the first powerful shock, but as one clock is sidereal and the other mean time, there is no assurance or even probability that the pendulums would be in the same relative position at the time of the arrival of the wave which gave the powerful shock. If the pendulums were not in the same relative parts of their beats, the chances are that one would be hung fast at least a second before the other. Now it was observed that the pendulum of the mean time clock was hung fast on the west side of its arc of oscillation, while the pendulum of the sidereal clock was hung fast on the east side. Both pendulums swing in the plane of the prime vertical. The difference in the time shown by the two clocks

is probably due therefore to slight derangements by the preliminary shocks, and to the instantaneous positions of the pendulums, which enabled one to be hung fast a second or more before the other; but I think the mean time here adopted is likely to be correct within 1 second.

Mr. J. D. Maddrill, in charge of seismographs and earthquake reports at Lick Observatory, Mount Hamilton, reports the beginning of the shock there, as the result of several observations, as 5<sup>h</sup> 12<sup>m</sup> 12<sup>s</sup>. Mr. R. G. Aitken timed the heavy shock at 5<sup>h</sup> 12<sup>m</sup> 45<sup>s</sup>, which corresponds exactly with the starting of the Ewing three-component seismograph.

On comparing these accounts, we notice that Professor See alone, probably on account of his unusually favorable situation, observed a very slight movement between 5<sup>h</sup> 11<sup>m</sup> and 5<sup>h</sup> 12<sup>m</sup>, and soon afterwards the violent shocks began, which correspond to the beginning noticed by Professor Davidson, Professor McAdie, Dr. Albrecht, and the Lick observers; this part of the disturbance was very strong, tho much lighter than the very violent shocks which occurred later. We shall refer to it as the *beginning of the shock*, looking upon the earlier, extremely slight movement observed by Professor See as a preliminary movement. Dr. Albrecht reports the heaviest shock at 30 or 40 seconds after the beginning; Mr. Aitken is corroborated by the starting of the seismograph at Lick Observatory in putting the heavy shock at 5<sup>h</sup> 12<sup>m</sup> 45<sup>s</sup>, *i.e.*, 33 seconds after the beginning; and the most reliable clocks that were stop'd agree in indicating a similar interval between the beginning and the shock that stop'd them. As pointed out by Prof. C. F. Marvin,<sup>1</sup> the evidence is convincing that the clocks in general were stop'd by the *violent shock*, which occurred about a half minute after the *beginning*, and was alone strong enough to affect seismographs at distant observatories.

#### THE BEGINNING OF THE SHOCK.

The majority of the reports as to the time of the beginning of the shock are only roughly approximate, but we fortunately have four very reliable observations, all of which are given by astronomers, who are accustomed to accurate estimates of small intervals of time.

First, San Francisco: Prof. George Davidson gives the time as 5<sup>h</sup> 12<sup>m</sup> 00<sup>s</sup>  $\pm$  2 seconds, Pacific Standard Time, which is 8 hours slow of Greenwich Mean Time. Mr. Van Ordine, who had a stop-watch, gives the time as 5<sup>h</sup> 12<sup>m</sup> 10<sup>s</sup>; his watch was set two days before the earthquake and his time is not so reliable as that of Professor Davidson. Professor McAdie's time may be looked upon as confirming Professor Davidson's; all the reliable observations, as well as the reliable stop'd clocks, make it absolutely certain that the shock began about 5<sup>h</sup> 12<sup>m</sup> and we must assume that Professor McAdie, suddenly awakened by a strong earthquake, made an error in reading the minute-hand of his watch, an error which is very easy to make; or that he applied the approximate correction and wrote down the corrected time. We shall accept Professor Davidson's time as the most accurate obtainable for San Francisco.

Second, Students' Observatory, Berkeley: Dr. S. Albrecht, 5<sup>h</sup> 12<sup>ra</sup> 06<sup>s</sup>.

Third, Lick Observatory, Mount Hamilton: The result of the observations of several astronomers, 5<sup>h</sup> 12<sup>m</sup> 12<sup>s</sup>.

Fourth, International Latitude Station, Ukiah: Prof. S. M. Townley, 5<sup>h</sup> 12<sup>m</sup> 17<sup>B</sup>. Professor Townley had been at work very late the previous night and was sleeping soundly when he was awakened by the earthquake. He immediately arose and went to the window and took the time of his watch, which when corrected became 5<sup>h</sup> 12<sup>m</sup> 32<sup>s</sup>. Professor Townley estimates that 10 seconds may have elapsed from his first awakening and his reading of the watch, and that it may have taken 5 seconds for the disturbances

<sup>1</sup> Professor Marvin's Preliminary Report to the Commission on the Stop'd Clocks has been drawn upon freely in this discussion.

to awaken him, and therefore that the time of the arrival was 5<sup>h</sup> 12<sup>m</sup> 17<sup>s</sup>. This time is far less accurate than the others but is certainly not more than a few seconds wrong and is important in estimating the origin of the shock on account of the location of Ukiah with respect to the other stations. This will be readily seen on referring to map No. 23 and to fig. 1, in which the long vertical line represents the fault, and the positions of stations with respect to it are shown.

There are, then, only four observations which should be taken into account in estimating the position of the centrum, which, we may assume, lies somewhere in the apparently vertical plane of the fault. The question arises whether the slip took place at various parts of the fault simultaneously, or, whether it occurred first over a limited area, and the stress, being relieved here, increased at other places, and thus the rupture spread along the fault, in both directions, at a rate probably somewhat less than that of the propagation of elastic waves of compression. In the first case the movement would have been propagated at right angles to the fault, and would have arrived at the various stations after intervals of time proportional to their distances from the fault-line. Taking our origin of time at 5<sup>h</sup> 12<sup>m</sup> 00<sup>s</sup> we have the following data (where the *f*s are the times of arrival after 5<sup>h</sup> 12<sup>m</sup> 00<sup>s</sup>, and the *d*'s are the distances from the fault-line): San Francisco, *t*<sub>1</sub> = 0 seconds, *d*<sub>1</sub> = 12 km.; Berkeley, *t*<sub>2</sub> = 6, *d*<sub>2</sub> = 29; Mount Hamilton, *t*<sub>3</sub> = 12, *d*<sub>3</sub> = 33.7, Ukiah, *t*<sub>4</sub> = 17, *d*<sub>4</sub> = 42.6. (These distances are determined from the maps and are not taken from fig. 1, where the fault is represented as perfectly straight.)

If we attempt from these data to determine the most probable value of the velocity and of the time of occurrence by the method of least squares, we find a velocity of 1.8 km./sec. and a time of 5<sup>h</sup> 11<sup>m</sup> 52.5<sup>s</sup>, with errors of -0.9, -1.2, -0.8, -1.0 seconds for the stations in the order given above; the sum of the squares of the errors is 8.6; the positive sign indicates that the observed times were too early, and *vice versa*. The small velocity calculated is quite inadmissible; and we therefore try the other alternative to see if it does not yield better results. We may consider that we have four unknown quantities to be determined: the time of the shock, the distance of the centrum measured along the fault-line from a given point of reference, its depth below the surface, and the rate of propagation. Four observations are sufficient to determine these four quantities, but the observations we have lead to impossible results, which may be seen by a general comparison of the positions of the stations and the times observed at them. For evidently there is no point on

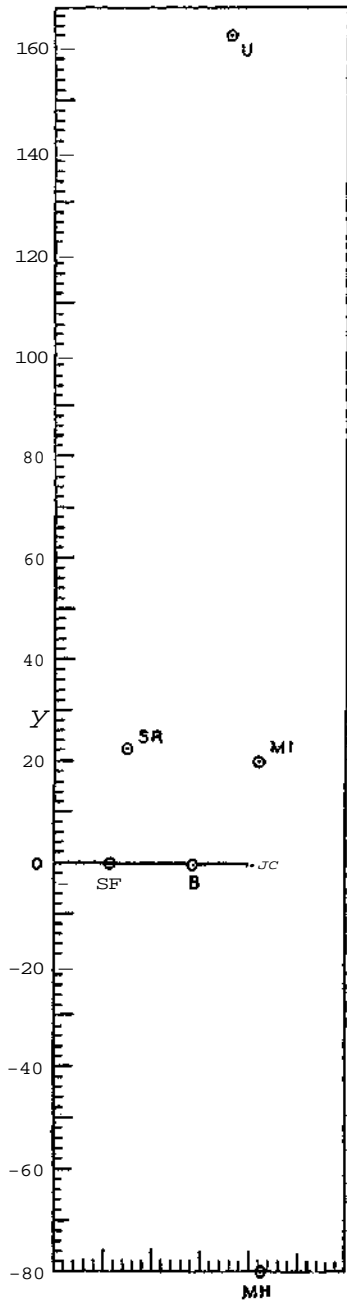

FIG. 1.

	<i>x</i> (km.)	<i>y</i> (km.)
Ukiah . . . . .	36.1	160
San Rafael . . . . .	15.2	25
Mare Island . . . . .	42.15	20
San Francisco . . . . .	11.7	0
Berkeley . . . . .	28.85	0
Mount Hamilton . . . . .	42.7	-80

the fault-line so situated that the difference of the distances from it of Berkeley and San Francisco is half the difference of the distances from it of Mount Hamilton and

San Francisco, and one-third the difference of the distances of Ukiah and San Francisco; which shows that the observations are not accurate enough to make an exact determination of the unknown quantities possible. We are led therefore to assume a rate of propagation, and by trial to find the place on the fault-plane which will accord best with the observations; that is, which will make the sum of the squares of the errors least. In the neighborhood of an earthquake origin, the preliminary tremors, the second phase, and the long waves (which will be described further on) are not separately distinguishable; and there are very few and unsatisfactory observations regarding the rate at which the disturbance is propagated.

Professor Imamura<sup>x</sup> calculates the velocity as 7.5 km./sec. from observations at Tokyo of earthquakes originating at an average distance of 679 km., the greatest distance being less than 1,300 km. Corresponding observations at Osaka give a velocity of 7.9 km./sec. for an average distance of 792 km., but they are rendered unreliable on account of the poor clock at that station. By the difference method, that is, by dividing the difference of the distance from the origin of two stations by the difference of time of arrival at them, he finds an average velocity of 12.1 km./sec, the stations ranging in distance between 284 and 1,285 km. from the origin. From observations at Tokyo and Mizusawa he finds by a similar method an average velocity of 9.6 km./sec. for an average distance of 522 km. from the origin, and 12.4 km./sec. for an average of 984 km.

Professor Omori<sup>2</sup> finds for the velocity of two earthquakes between Taichu, near their origin in Formosa, and Tokyo, a distance of 1,620 km., 6.13 km./sec. and 6.75 km./sec, respectively. Tokyo is 1,710 km. from the origin and Taichu 90 km. In the first case the time at Taichu was determined by a chronometer watch, in the second from the seismogram; in both cases the Tokyo time was determined from the seismograms.

Professor Credner<sup>3</sup> finds by the difference in time of arrival at Leipzig and Göttingen of two small earthquakes whose origins were about 100 km. south of Leipzig, a velocity of 5.9 km./sec. Göttingen is about 200 km. from the origin.

Professor Rizzo<sup>4</sup> from observations of the Calabrian earthquake of 1905 at two stations, Messina and Catania, distant 84 and 174 km., respectively, from the epicentrum, finds a surface velocity of 6.9 km./sec; this supposes the centrum at the surface; a deeper centrum would give a slightly smaller velocity. The tendency is always to obtain too low a value for the velocity. The strongest disturbance does not usually occur at the very beginning of the shock, but somewhat later; the earlier and lighter part is felt near the origin, but at a distance only the stronger part is observed; this is also true of seismograph records. The velocities calculated from such observations are evidently too small.

Professor Wiechert in a communication to the International Seismological Association in September, 1907, accepted 7.2 km./sec. as a fair value of the velocity near the surface of the earth; which is the same as the velocity near the origin. I have taken this value, 7.2 km./sec, as being probably as near the truth as we can come at present. With this velocity we find by the method of least squares that the most probable position of the centrum is at a point lying about 10 km. north of the point on the fault-line opposite San Francisco, and at a depth of 20 km. below the surface; the time of occurrence of the shock is 5<sup>h</sup> 11<sup>m</sup> 57.6<sup>s</sup>; and the errors in seconds are: San Francisco, +1.1; Berkeley, — 3.4; Mount Hamilton, — 0.2; Ukiah, -f 2.4; the sum of the squares of the errors is 18.6 seconds. The objection to this determination is the error at Berkeley which is

<sup>1</sup> Publications of the Earthquake Investigation Commission in Foreign Languages, No. 18, p. 102.

<sup>1</sup> Note on the Transit Velocity of the Fonnosan Earthquakes of April 14, 1906. Bull. Imperial Earthquake Investigation Commission, vol. i, No. 2, p. 73.

<sup>1</sup> Die Vogtlandische Erdbebenschwärm von 13 Feb. bis zum 18 Mai, 1903. Abh. math.-phys. Kl. K. Sachs. Gesells. d. Wissen. 1904, Bd. xxviii, p. 153.

<sup>4</sup> Sulla Velocità di Propagazione delli Ondi Sismiche nel Terremoto della Calabria. Accad. R. delli Science di Torino, 1905-1906, p. 312.

apparently too large. The 15 seconds which Professor Townley allowed for the interval between the arrival of the shock at Ukiah and the moment that he read his watch seems to me rather long; if we reduce this interval to 12 seconds and take the time of arrival at Ukiah at  $5^{\text{h}} 12^{\text{m}} 20^{\text{s}}$ , the observations become more accordant; we find that the best position for the origin has the same geographical position mentioned above, but the centrum is near the surface, and the time of the shock becomes  $5^{\text{h}} 11^{\text{m}} 59^{\text{s}}$ ; the errors of observations are: San Francisco, + 1.1; Berkeley, -2.8; Mount Hamilton, +0.9; Ukiah, + 0.7. The sum of squares of the error is 10.4 seconds. But the position of the centrum can not be looked upon as being determined very accurately; even if we put its depth at 30 km. we find the sum of the squares of the errors only 10.8 seconds; and the individual errors are: San Francisco, +1.9; Berkeley, -2.6; Mount Hamilton, + 0.6; Ukiah, +0.2. This is a better group of errors, as that of Mount Hamilton is very small. The time is  $5^{\text{h}} 11^{\text{m}} 57.7^{\text{s}}$ .

It will be noticed that the groups of errors seem slightly to favor the idea of a simultaneous slip along the fault-line in preference to the slip beginning over a small area and then gradually spreading along the line. But let us notice what this really involves. In the first place it requires a velocity of propagation of only 1.8 km./sec, a value less than a quarter as great as the most probable value of this velocity.<sup>1</sup> It may be urged that these times refer to the arrival of the large surface waves, whose velocity has been determined as about 3.3 km./sec.; but with this value of the velocity we find much larger errors, the sum of the squares amounting to 36.9; and therefore a consideration of the errors alone renders this supposition less probable than either of the other two; and, moreover, the preliminary tremors and large waves are not separated at such short distances from the origin as San Francisco and Berkeley.

Secondly, it is clear from the surveys of Messrs. Hayford and Baldwin (vol. i, pp. 114-145) and from the discussion of them (pp. 16-28) that the rupture along the fault-line was the result of gradually increasing forces which finally became greater than the strength of the rock; before rupture the rock yielded elastically to the forces and it seems absolutely impossible that its ultimate strength, varying locally, should have been reached simultaneously over the whole area of the fault-plane, whose length was 435 km., or indeed over any large area. It would require a nice adjustment of the forces concerned, which the nature of the forces in no way leads us to expect. It is only in the case of absolute rigidity, which is far from the true nature of rock, that we can conceive of a simultaneous movement along the whole fault; and then we should be at a loss to account for the dying out of the fault at its ends. Moreover, our general experience is entirely against simultaneous yielding; when structures, such as bridges, break, they give way first at a particular point; when an ice-jam in a river yields, one part yields before the rest; and, indeed, many such examples might be cited. We are therefore constrained to believe that the rupture on the fault-plane began over a small area and rapidly spread to other parts of the fault.

We may then consider the position of the origin as determined within, perhaps, 30 km. along the fault-line and within 20 km. in depth; and the time, within 3 seconds; and we may write for

$$\text{The beginning of the shock} \left\{ \begin{array}{l} t_0 = 13^{\text{h}} 11^{\text{m}} 58^{\text{s}} \pm 3 \text{ seconds G. M. T.,} \\ A = 121^{\circ} 36' \text{ W. } \pm 16', \\ \quad = 370 4^{\text{g}}, \text{ N } \pm 16', \\ \phi = 37^{\circ} 4^{\text{g}}, \text{ N } \pm 16', \\ z_0 = 10 \text{ km. } + 20 \text{ km. or } - 10 \text{ km.,} \end{array} \right.$$

where  $t_0$  is the time of the occurrence of the shock;  $X$ , the longitude, and  $\phi$ , the latitude,

<sup>1</sup> If we had taken the Ukiah time as  $5^{\text{h}} 12^{\text{m}} 20^{\text{s}}$ , the hypothesis of simultaneous slip would have required a velocity of 1.6 km./sec, and the sum of the squares of the errors would have been 17.4.

of the epicentrum; and  $z_0$ , the depth of the centrum. The point lies exactly opposite the Golden Gate.

If, instead of a velocity of 7.2 km./sec. we had used 6.5 or 8, the position and time of the shock would not have been altered beyond the limits of error indicated above. A smaller velocity would have led to a deeper centrum and earlier time; a greater velocity would have had the opposite effect.

#### THE VIOLENT SHOCK.

The violent shock is the most important part of the earthquake, both on account of its destructive effects and because it alone could have affected distant seismographs. Indeed, Victoria is the only distant station where the first motion was recorded and it is the nearest seismographic station beyond the limits of sensible motion. Its distance was 1,156 km. from the origin and the disturbance was perceptible to a distance of 550 km. A large number of clocks were stopt by the strong motion; and one would naturally look to them to get the exact time of its occurrence. Professor Marvin has collected together all information regarding these clocks. For the great majority the time of the stopping is only known to minutes, and even then the differences between the various clocks are so great as to make the resulting average of very little value; it is therefore not necessary to give here the times recorded by all of them. We fortunately have observations from four stations which seem to be very reliable.

First, San Rafael: Two standard clocks were stopt; one the standard clock of the Time Inspector of the North Shore Railroad, stopt at  $5^{\text{h}} 12^{\text{m}} 35^{\text{s}}$ ; the other, belonging to the night operator of the Railroad, stopt at  $5^{\text{h}} 12^{\text{m}} 30^{\text{s}}$ . Also a clock, belonging to the Western Union Telegraph Company, which sends out the time, stopt, the time being  $5^{\text{h}} 13^{\text{m}}$ ; as the seconds are not given it is probable that they were not observed. This time must, therefore, be neglected; it is manifestly too late. The first two clocks are supposed to be very accurate and to be checked every day at noon. The average of their time is  $5^{\text{h}} 12^{\text{m}} 32.5^{\text{s}}$ .

Second, Mare Island: Two of the astronomical clocks, under the charge of Prof. T. J. J. See, stopt respectively at  $5^{\text{h}} 12^{\text{m}} 35^{\text{s}}$  and  $5^{\text{h}} 12^{\text{m}} 37^{\text{s}}$ . A third clock which is electrically corrected every day, but is not a standard clock, stopt at  $5^{\text{h}} 12^{\text{m}} 33^{\text{s}}$ . Professor See thinks the best time is the average of the two astronomical clocks, namely,  $5^{\text{h}} 12^{\text{m}} 36^{\text{s}}$ .

Third, Berkeley: The astronomical clock at the Students' Observatory, under the charge of Prof. A. O. Leuschner, stopt at  $5^{\text{h}} 12^{\text{m}} 39^{\text{s}}$ .

Fourth, Mount Hamilton: The only clock that stopt was a small one in the Director's office, the correction for which was not accurately known; it stopt at  $5^{\text{h}} 12^{\text{m}} 52^{\text{s}}$ ; we can not put any reliance on the exact time it gives. The shock began at Mount Hamilton at  $5^{\text{h}} 12^{\text{m}} 12^{\text{s}}$ , but the strong shock occurred at  $5^{\text{h}} 12^{\text{m}} 45^{\text{s}}$ . This is attested by the observation of Mr. Aitken and also by the fact that the Ewing seismograph was set in motion at that time. This seems the most accurate record we have of the time of the arrival of the heavy shock at a station near the origin.

The sidereal clock at the Chabot Observatory, Oakland, stopt at mean time  $5^{\text{h}} 12^{\text{m}} 51^{\text{s}}$ . The mean time clock stopt at  $5^{\text{h}} 14^{\text{m}} 48^{\text{s}}$ . Professor Marvin, however, has pointed out that the delicate gravity escapement of the latter might easily be thrown out of adjustment by the disturbance and thus allow the clock to race. It is evident that we can not take into consideration the time given by it. The sidereal clock, stopping 14 seconds later than the clock at Berkeley, may perhaps have been stopt, restarted, and stopt again by the shock. At any rate it is certainly too late and must be neglected. One clock at Ukiah may have been stopt and restarted; it was going after the shock,



but had been retarded by 6 seconds in time. Two of the astronomical clocks at Mare Island continued going after the shock, but they lost 20 seconds, which Professor See ascribed to "the rubbing of the pendulum points against the index ledges, which was also clearly shown by the brightening of the metal of the indexes." Altho this friction must have acted, it hardly seems sufficient to account for so large a loss in the minute or so of the strong shocks, and it is not unlikely that these clocks were stopt and started again. Some clocks must have been stopt at very nearly the correct time of the arrival of the shock, but it is impossible to distinguish them from other clocks, whose times are claimed to be correct, but which were evidently wrong; it is best, therefore, only to use times from the first four observations mentioned, which have been chosen because they can be relied on as very nearly correct.

The clocks which stopt evidently too late, and those which continued going but with the loss of some seconds of time, call attention to an error which may be made if we accept the time of a stopt clock as determining the time of the heavy shock. Let us notice in the first place that it is scarcely possible for the time thus determined to be too early; for, if the pendulum is made to vibrate too rapidly for a beat or two before it is stopt, the time is advanced; and if the pendulum is stopt, started, and stopt again, the clock will mark too late a time. It is only in case the gentler motion preceding the heavy shock should cause the pendulums to vibrate too slowly, that the stopt clock would indicate too early a time; but this gentler motion is just as apt to make the pendulums vibrate too fast. The difference between the time of the heavy shock at Mount Hamilton, which does not depend upon a stopt clock, and the times recorded by the stopt clocks at San Rafael, Mare Island, and Berkeley, make it evident that the latter could not indicate a time materially too late, unless we assume a rate of propagation of the disturbance much too low to be permissible. It is extremely probable, however, that the clocks did indicate a time slightly too late, and I have therefore taken for the times of arrival of the heavy shock at Mare Island and Berkeley one second earlier than the clocks indicated; these clocks were all astronomical clocks, and, with their known corrections, were practically correct just before the shock. The clocks at San Rafael were not astronomical clocks and may have been a little too fast; we can take  $5^{\text{h}} 12^{\text{m}} 32^{\text{s}}$ , a half second earlier than their average, as the time of the shock at that place. The time at Mount Hamilton requires no modification.

We have therefore for the times, after  $5^{\text{h}} 12^{\text{m}} 30^{\text{s}}$ , of arrival of the heavy shock and the distances of the stations from the fault-line: San Rafael,  $t_1 = 2$  seconds,  $d_1 = 16$  km.; Mare Island,  $t_2 = 5$ ,  $d_2 = 42$ ; Berkeley,  $t_3 = 8$ ,  $d_3 = 29$ ; Mount Hamilton,  $t_4 = 15$ ,  $d_4 = 33.7$ . A glance at these data show that the shock was not simultaneous along the fault-line, for Berkeley and Mount Hamilton, less distant from the fault-line than Mare Island, felt the shock later. The times, with the positions of the stations as shown in fig. 1, indicate that the strong shock originated in a limited area somewhere to the northwest of San Rafael.

If, as in the case of the *beginning of the shock*, we use these four observations to determine our four unknown quantities, we find an imaginary value for the depth of the centrum, showing that the observations are not perfectly accurate. We may then, as before, assume various positions for the centrum and find by the method of least squares what time of occurrence and what velocity of propagation will make the sum of the squares of the errors least. The following table shows the results of these determinations;  $y_0$  is the distance from a point on the fault-line opposite San Francisco to the origin, measured towards the northwest;  $z_0$  is the depth of the centrum below the surface;  $t_0$ , the time of occurrence, in seconds after  $5^{\text{h}} 12^{\text{m}} 30^{\text{s}}$ ;  $v$ , the velocity of propagation in kilometers per second; and  $A^2$ , the sum of the squares of the errors in seconds between the calculated and observed times. It is to be noticed that the velocity is too high except in one case.

TABLE 1. — *Times, Velocities, and Errors for Various Positions of the Focus.*

$y_0$	$z_0$	$t_0$	$v$	$\Delta^2$
20	0	31.0	7.7	5.0
20	20	29.8	7.2	10.2
40	0	30.1	8.3	4.9
40	20	28.9	8.7	5.9
50	20	29.2	8.8	5.3

If now we assume a velocity of 7.2 km./sec, and repeat the calculations determining only  $t_0$ , we get the following results for various positions of the centrum:

TABLE 2. — *Times and Errors for Various Positions of the Focus.*

$y_0$	$z_0$	$t_0$	$A^2$	$y_0$	$z_0$	$t_0$	$A^2$
20	0	30.5	9.3	50	0	27.8	7.6
20	20	29.8	10.2	50	20	27.4	7.7
30	0	29.8	8.9	60	0	26.7	8.3
30	20	29.2	7.2	60	20	26.2	7.6
40	0	28.9	6.7	60	40	25.1	6.7
40	10	28.8	6.9	100	0	21.9	16.6
40	20	28.4	6.6	100	20	21.6	16.0

There is not a very great difference in the sums of the squares of the errors for values of  $y_0$  varying between 20 km. and 60 km., but they increase at both of these extreme distances (errors of a few tenths are insignificant as they are partially due to approximations in the calculations); and the times of course become earlier as the origin is placed further northwest. We may therefore adopt for the approximate position of the centrum of the violent shock,  $y_0 = 40 \text{ km.} \pm 20 \text{ km.}$ ,  $z_0 = 20 \text{ km.} \pm 20 \text{ km.}$ , and for the time of occurrence,  $t_0 = 5^{\text{h}} 12^{\text{m}} 28^{\text{s}} \pm 2 \text{ seconds}$ . The individual errors of the times of observation become at San Rafael, Mare Island, Berkeley, and Mount Hamilton, respectively, + 0.6 second, - 0.4, - 2.1, + 1.3. If in these calculations we had used a velocity of 6 km./sec. or 8 km./sec, our results would not have been altered beyond the uncertainty indicated. We may therefore write for

$$\text{The violent shock } \left\{ \begin{array}{l} t_0 = 13^{\text{h}} 12^{\text{m}} 28^{\text{s}} \pm 2 \text{ seconds G. M. T.}, \\ \bar{X} = 122^{\circ} 48' \text{W.} \pm 5', \\ \langle z \rangle = 38^{\circ} 03' \text{N.} \pm 4', \\ z_0 = 20 \text{ km.} \pm 20 \text{ km.} \end{array} \right.$$

The point lies between Olema and the southern end of Tomales Bay. This position of the point of beginning of the *violent shock* receives some confirmation by the fact that the violence of the shock was probably as great in this neighborhood as anywhere, and that the displacements along this part of the fault-line were the greatest recorded.

THE DEPTH OF THE FOCUS.

There are two ways of determining the depth of the focus: by observations of the times of arrival of the shock at various stations and by a consideration of the distribution of the damage and other effects produced by the disturbance over the surface of the earth. The two methods do not determine identically the same point. The time method gives the location and depth of the point where the shock started, whereas the method depending upon the distribution of intensity gives the depth of the whole of the fault-plane.

First: a glance at fig. 2, where  $F$  represents the focus of the shock, will show very clearly that the distance from the focus to the various stations depends upon its depth, and if we

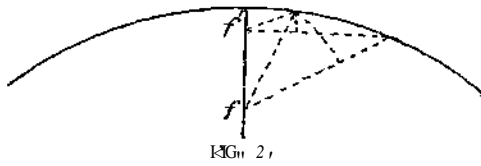

FIG. 2,

knew the exact time of the shock, the time of the arrival at the stations and the velocity of propagation, we could immediately calculate the depth of the focus. As a matter of fact we do not know the exact time of the shock, nor do we know the exact velocity, but by

observations at a number of stations all these quantities could be determined, provided the observations were sufficiently accurate. Here, however, is where the difficulty lies. The table on page 119, which gives the time of the arrival of a disturbance according to the distance of the station from the epicenter and the depth of the focus, shows that this time is very slightly affected by the depth of the focus when the distances are as great as three or four times this depth; and therefore to get from time observations an even fairly approximate value of the depth we must have a number of stations very close to the epicenter, and the observations must be extremely accurate — to within a second or so. Neither of these conditions have been satisfactorily fulfilled heretofore, and determinations of the depth of the focus based on this method are unreliable. In the case of the California earthquake the observations at the four stations considered are probably more favorable, both as to the situations of the stations and the accuracy of the observations, than has been realized at any former earthquake; but nevertheless it has been shown that they are not sufficiently accurate to determine the various unknown quantities in the problem, and they merely indicate that the depth at which the violent shock originated is probably not more than 40 km. The variation of this method by the use of Seebeck's or Schmidt's hodographs can not yield more reliable results; and its application when the time of arrival, not of the beginning of the shock, but of a strong reinforcement of the motion, is used is by no means to be recommended; for in this case we can not say that the special part of the disturbance observed has traveled directly thru the body of the earth; and the whole theory of the method depends upon this supposition. In some cases it is quite evident that the time of arrival of the long waves has been used, and these waves are supposed to be propagated along the surface.<sup>1</sup>

Second: the distance of points from the focus will increase more slowly with their distance from the epicenter for deep than for shallow foci, and therefore the intensity of the action at the surface will diminish more slowly. Maj. C. E. Dutton has shown that if we consider the extent of the origin small and the damage done by the shock at the surface proportional to the energy of the motion there, the change in the amount of damage will be most rapid at a distance from the epicenter of about 1.7 times the depth of the focus; and this distance is independent of the actual intensity of the shock.<sup>2</sup>

If we attempt to apply this method to the California earthquake, we meet with many difficulties. The disturbance was by no means confined to a small area, but was spread, more or less unevenly, over the whole fault-plane. It probably did not take place simultaneously, but varied in time at different parts of the fault. If it had occurred simultaneously, the method might be applied by adding up the effects due to the different parts of the fault, but if the movement occurred even at slightly different times in different parts of the fault, their effects at some points would be successive and at some points simultaneous. The general averaging of these results might, however, enable us to form a rough

<sup>1</sup> See for example Faidiga; "Das Erdbeben vom Sinj am 2 Juli, 1895," Mitt. Erdb.-Com., K. Akad. Wiss. Wien, No. XVII, 1903. The time of arrival of the second preliminary tremors would be a better time to use than that of the first preliminary tremors; for they travel only about two-thirds as fast, and therefore the differences in their times of arrival would be somewhat greater at two stations of slightly different distances from the centrum.

<sup>2</sup> The Charleston Earthquake of August 31, 1886. 9th Ann. Rep. U. S. Géol. Surv., 1887-1888, pp. 313-317.

estimate of the depth if we were not confronted by another difficulty, namely the variations of the effects due to the character of the foundation. These variations, as shown on the general map, No. 23, and on the intensity map of the city of San Francisco, No. 19, are so great that it is quite impossible to obtain accurate values for the depth of the fault all along its course; but opposite Point Arena the isoseismals are sufficiently regular to throw some light on the subject. In attempting to solve this problem, we must make a number of assumptions, which are by no means exactly true, but are nearly enough so to make our result of some value; they are: that the amount of energy sent out by each element of the fault-plane per unit time was the same; that the amount of energy sent out in any direction from each element was proportional to the cosine of the angle between that direction and the normal to the fault-plane; that the strong disturbance continued for a sufficient time all along the fault-plane to permit us to assume that points not very distant were receiving simultaneously the strong vibrations from a length of the fault-plane 8 or 10 times as great as their distances from it; and that the effective force at any point is proportional to the square root of the energy of the disturbance at that point.

With these assumptions we can determine the energy of the disturbance at any point not far from the fault by adding together the amounts of energy sent to that point by each element of the line.

The vibrational disturbances at the various points of the fault-plane do not unite to form a single wave-front, for the movements must be in different phases at different points, and both distortional and longitudinal vibrations in various directions are present; for this reason it might appear that the energy would be sent out uniformly in all directions and not according to the cosine law; but if we make this assumption, we find an infinite amount of energy near the fault, which is, of course, impossible, and we are therefore led to assume the cosine law, which is probably not very far wrong.<sup>1</sup>

For a simple harmonic vibration of a given period the energy of the motion is proportional to the square of the amplitude, and the maximum acceleration to the amplitude itself, that is, to the square root of the energy. When we consider that, at every place where the disturbance was felt, the vibrations were in all directions and had various periods and amplitudes, we see that it is quite impossible to determine the true acceleration, but the square root of the energy will be roughly proportional to it. Professor Omori has shown that the effective force is proportional to the acceleration and has estimated the values of the various degrees of the Rossi-Forel Scale in terms of actual accelerations.<sup>2</sup>

In fig. 3 let  $P$  be the point on the earth's surface at which the disturbance is to be determined and  $x$  its perpendicular distance from the fault-plane,  $O'Obb''$ . Let  $b$  be any element of the fault-plane, whose depth below the surface is  $z$  and whose distance from  $O'$ , measured parallel to  $O'b'$ , is  $y$ . Then the energy of the disturbance at  $P$  is found by adding the amounts sent from all such elements of the fault-plane, remembering that the intensity

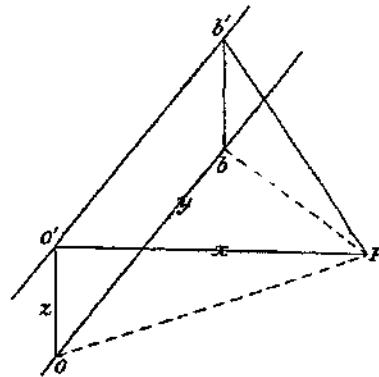

FIG. 3.

<sup>1</sup> It is also probable that the vibrations sent out from each point are regular only for a very short time. These considerations lead to the conclusion, that no places on the earth's surface experience a low intensity of disturbance on account of the interference of vibrations; for altho the interference might exist at a particular moment, the irregularity of the motion would only allow it for a very short time; and the intensity ascribed to a particular place is the maximum intensity which is felt there at any part of the shock. On the other hand, it is quite possible for strong vibrations from two parts of the fault-plane to combine and cause unusual intensity along a particular line or zone. No definite instances of this, however, can be cited in the case of the California earthquake.

<sup>2</sup> Publications of the Earthquake Investigation Commission in Foreign Languages, No. 4.

dies down inversely as the square of the distance; the energy at  $P$  is, therefore, proportional to

$$\frac{B}{I} \int_{-\infty}^{\infty} \frac{u \cos \theta}{r^2} dx$$

where  $D$  is the depth of the fault. The limits of the integral along the fault assume an infinite length for the fault; but the result is practically the same if the angle between two lines drawn from the ends of the fault to  $P$  is nearly  $180^\circ$ ; that is, if the distance of  $P$  from the fault is small compared with its length. The values of  $\sqrt{\tan^{-1} \frac{D}{x}}$  have been plotted in fig. 4 in terms of  $\frac{x}{D}$ . It will be noticed it is a function of  $\frac{x}{D}$  and is independent of the actual intensity of the disturbance at the fault-plane; but unlike Major Dutton's energy curves, there is no point of inflection in our curve (this is due

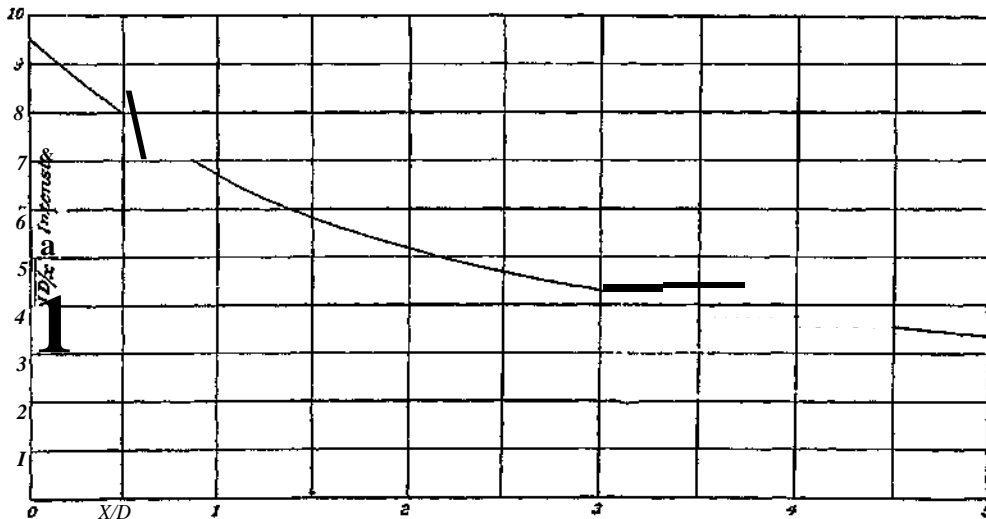

FIG. 4.

to the fact that the fault-plane is not confined to a considerable depth, but extends to the surface of the earth). We must therefore, to determine the depth of the fault, determine the distance of the point where the force bears some definite proportion to the force in the immediate neighborhood of the fault-plane, for instance, where it is half as great. We find from the curve that the distance of this point is about 2.5 times the depth of the fault. We must, now, from our map of intensities determine the actual distance from the fault-plane of the points where the force had diminished to half its value at the fault-line. Professor Omori \* has estimated that the acceleration on the made ground in San Francisco was somewhat less than 2,500 millimeters per second per second, and therefore the acceleration on rock at the fault-plane may be taken at about this value. According to Professor Omori's scale, a force about half as great, or 1,200 millimeters per second per second, corresponds to the degree VIII of the Rossi-Forel Scale, and this isoseismal occurs at a distance of about 20 km. from the fault-line opposite Point Arena; 20 km. is therefore 2.5 times the depth of the fault, which accordingly becomes 8 km. We must not attach too much importance to this result; the assumptions and the data are all too inaccurate, but we can accept it as indicating that in the neighborhood of Point Arena the fault could hardly have extended to a greater depth than 20 km. and probably was not so deep. The distribution of isoseismals north of

<sup>1</sup> Bull. Imperial Earthquake Investigation Commission, vol. i, No. 1, p. 19.

San Francisco Bay show that this conclusion is applicable to all that part of the fault; but further south the isoseismals, where not greatly affected by soft ground; lie close to the fault, indicating a smaller depth.

Both methods of determining the depth of the fault agree in indicating that it is comparatively shallow; the only considerations opposing this are: its length, its comparative straightness, its independence of the topography, which it seems to have controlled rather than to have followed, and the very considerable geologic time which has elapsed since movements were first inaugurated along the rift (vol. i, pp. 48-52). All these facts undoubtedly suggest great depth, but our ignorance of the causes leading to the fault movements makes us attach greater weight to the more definite conclusions already arrived at, and to regard the movement of April 18, 1906, as comparatively shallow. It is the general belief of geologists that fractures of the rock are confined to a crust of small thickness; Professor Van Hise estimates that about 12 km. is the greatest depth to which they can reach, and he bases this estimate on the consideration that the weight of the overlying rock is sufficient at that depth to prevent the formation of cracks or crevices. He writes: "In rocks which were bent when so deeply buried that cracks or crevices could not form even temporarily, it is probable that the material flowed to its new position quietly, without shock, under the enormous stress to which it was subjected."\* But this is not a sufficient criterion; rock can fracture by shearing without the formation of crevices just as a block can slide on a second one without separating from it; in the case of the California earthquake there is no necessity for believing that the two sides of the fault did not always remain in contact while they were slipping past each other, and, as is pointed out further on, the movement near the ends of the fault is taken up by elastic or plastic distortion.

The temperature increasing with the depth increases the plasticity of the rock, but the increasing pressure increases its rigidity to a greater extent, at least for forces like those due to elastic vibrations and the tides of short periods, which do not continue to act for a very long time in the same direction; but for long-continued forces in the same direction, provided they do not increase too rapidly in intensity, the plasticity probably allows slow deformation and prevents the forces from ever reaching the ultimate strength of the rock.

The question which must be answered to determine the depth to which fractures can occur is: At what depth does the plasticity of rock become sufficient to enable it to yield to the stress-difference, which may exist there, rapidly enough to prevent this stress-difference from reaching the ultimate strength of the rock? Unfortunately we do not know any of the elements of the problem, neither the plasticity of the rock as dependent on pressure and temperature, nor the rate at which stress-differences accumulate at distances below surface. It is probable that the point at which a fracture first occurs is not the lowest point to which it extends; for when the break comes, the forces are suddenly transferred to nearby points, and thus the fracture may be carried to depths where no fracture would take place otherwise.

There is very little observational evidence bearing on the question we are discussing. The Appalachian Mountains are characterized in Pennsylvania by open folds and few faults; as we follow the range to the southwest the folds become closer and the faults increase, and in Tennessee, North Carolina, Georgia, and Alabama, the faulting becomes excessive. Mr. Bailey Willis has pointed out<sup>3</sup> that the thickness of the sediments above the Cambro-Silurian limestone was about 23,000 feet (7,000 meters) in Pennsylvania, 10,000 feet (3,000 meters) in southwestern Virginia, and only 4,000 feet (1,200 meters) in Alabama; and he thinks the differences in folding and faulting are due to the differences of the loads when the deformations took place. This indicates that faults are very shallow.

---

<sup>1</sup> Principles of Pre-Cambrian Geology, 16th Ann. Rep. U. S. Geol. Surv., 1894-95, pp. 593-595.

\* Mechanics of Appalachian Structure, 13th Ann. Rep. XL S. Geol. Surv., 1891-02, p. 269.

## PERMANENT DISPLACEMENTS OF THE GROUNDS.

### THE RESULTS OF THE SURVEYS.

Accurate surveys of a part of the region traversed by the fault-line of 1906 were made by the U. S. Coast and Geodetic Survey at various times. These have been grouped for the sake of discussion into three periods, namely: I, 1851-1865; II, 1874-1892; III, 1906-1907. These surveys, as discust by Messrs. Hayford and Baldwin (vol. i, pp. 114-145), show that in the intervals between the surveys certain definite displacements of the land took place. They bring out especially well the displacements which took place in the region north of San Francisco and the Farallon Islands during the time between the II and III surveys, an interval which included the earthquake of 1906. The field observations and the surveys were complementary; the former determined the relative displacements at the fault-line, and the latter the displacements at a

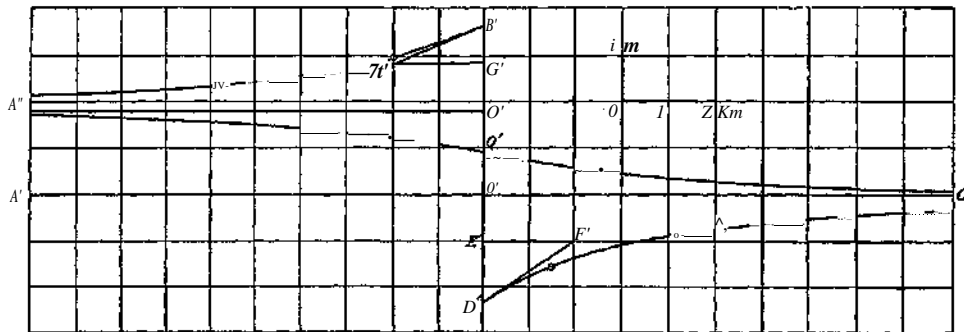

FIG. 5.

distance from it. The results of Messrs. Hayford and Baldwin may be expressed by fig. 5; they show that the displacements reached a maximum at the fault and were smaller as the distance from the fault was greater, in such a way, that a line which, at the time of the II survey, was straight, as A'O'C, had, at the time of the III survey, been broken at the fault and curved into the form A'B', D'C'. And, altho at a few points there is an indication of a compression or an extension at right angles to the fault, generally the movement was parallel with it. The figure is drawn to scale from the summary on page 133 (vol. i) and shows how the displacements diminish with the distance from the fault. The scale of displacements is 1,000 times that of distances; the curvature of the lines is so very small that it would be imperceptible if the two scales were the same.

The known length of the fault is about 435 km. (270 miles) and it is quite possible that it may be somewhat longer below the surface. Whatever may be its length, the fault terminates at some points beyond which no slip took place; the eastern side of the fault moved towards the southern region of rest and away from the northern region of rest; and the western side of the fault did just the opposite; there must have resulted near the northern end of the fault a compression of the land on the western side and an extension on the eastern; and near the southern end the extension must have been on

the western side and the compression on the eastern side. There may have been a more or less irregular distribution of compressions and extensions along the course of the fault due to differences in the amount of the movement, but these, according to Dr. Hayford, are slight except in the region just south of San Francisco. The question arises: How were these compressions and extensions taken up? Did the volume remain constant and the density change; or did the density remain constant and the volume change; or did both changes occur? We have not sufficient evidence to answer this question; but the general properties of matter would indicate that both changes occurred. To the north of San Francisco Bay there seems to have been, in places, a very slight elevation of the land west of the fault, and the only satisfactory explanation so far offered of the action of the tide-gage at Fort Point (described in vol. i, pp. 367-371) indicates a small depression of the west side of the fault opposite the Golden Gate. It is not impossible, altho it is by no means clearly indicated, that the slight elevation of the western side along the northern part of the fault may be due to an increase in volume there, and that the probable depression opposite the Golden Gate may be due to a decrease in volume, which must have taken place in that region, on account of the smaller displacement just south of it.

Returning now to the curving of former straight lines at right angles to the fault as shown in fig. 5, the first analogy suggested by the lines is that of a bent beam. If a beam, which is long in proportion to its thickness, is supported at one end and a weight hung from the other, the beam bends into a curve very much like that shown in the figure; the under, concave surface is compressed; the upper, convex surface is stretched; and between the two there is a neutral plane which is neither compressed nor stretched. But when the thickness of the beam is great in comparison with its length, the distortion is due to the elastic shear of each layer over its neighbor. In this case the thickness of the beam would be 435 km. (270 miles) and the length probably less than one-twentieth as much; so that the distortion must have been due to shear and not to bending in the ordinary sense of the word.

#### THE NATURE OF THE FORCES ACTING.

We know that the displacements which took place near the fault-line occurred suddenly, and it is a matter of much interest to determine what was the origin of the forces which could act in this way. Gravity can not be invoked as the direct cause, for the movements were practically horizontal; the only other forces strong enough to bring about such sudden displacements are elastic forces. These forces could not have been brought into play suddenly and have set up an elastic distortion; but external forces must have produced an elastic strain in the region about the fault-line, and the stresses thus induced were the forces which caused the sudden displacements, or elastic rebounds, when the rupture occurred.<sup>1</sup> The only way in which the indicated strains could have been set up is by a relative displacement of the land on opposite sides of the fault and at some distance from it. This is shown by the northerly displacement of the Farallon Islands of 1.8 meters between the surveys of 1874-1892 and 1906-1907, but the surveys do not decide whether this displacement occurred suddenly at the time of the earthquake, or grew gradually in the interval between them; there are valid reasons, however, for accepting the latter alternative, as the following considerations show: The Farallon Islands are far beyond the limits of the elastic distortion revealed by the surveys, so that we can not ascribe their displacement to elastic rebound; and we have seen that this is the only kind of force which could have produced a sudden movement; and what

<sup>1</sup> We use the words *strain* and *stress* as they are used in the theory of elasticity. A *strain* is an elastic change of shape or of volume caused by external forces; and a *stress* is a resisting force which the body opposes to a strain, and with which it tends to diminish it.





opposite sides of the fault since that date amounts to about 3.2 meters, a little more than half enough to account for the slip on the fault-plane; therefore 50 years ago the elastic strain, which caused the rupture in 1906, had already accumulated to nearly half its final amount. It seems not improbable, therefore, that the strain was accumulating for 100 years, altho there is no satisfactory reason to suppose that it accumulated at a uniform rate.

We can picture to ourselves the displacements and the strains which the region has experienced as follows: let  $AOC$  (fig. 6) be a straight line at some early date when the region was unstrained. By 1874-1892,  $A$  had been moved to  $A'$  and  $C$  to  $C'$ , and  $AOC$  had been distorted into  $A'O'C'$ ; by the beginning of 1906,  $A$  had been further displaced to  $A''$  and  $C$  to  $C''$ , the sum of the distances  $AA''$  and  $CC''$  being about 6 meters; and  $AOC$  had been distorted into  $A''O'C''$ . When the rupture came, the opposite sides of the fault slipped about 6 meters past each other;  $A''O$  and  $C''O$  straightened out to  $A''O'$  and  $C''Q'$ ; and the straight lines which occupied the positions  $A'O'$  and  $C''Q'$  just before the rupture, were distorted afterward into the lines  $A''B''$  and  $CD''$ , these lines being exactly like the lines  $A''O$  and  $C''O$  but turned in opposite directions. The straight lines, which occupied the positions  $A^fO'$  and  $C^fQ'$  in 1874-1892, were distorted into  $A''O'$  and  $C''Q'$  in the beginning of 1906; at the time of the rupture their extremities on the fault-line had the same movements as other points on that line;  $O'$  moved to  $B^f$  and  $Q'$  to  $D'$ . If we should move the left half of our figure so as to make  $A'O'$  continuous with  $C^fQ'$ , fig. 6 would then be practically similar to fig. 5 and similar letters in the two figures would refer to the same points; in fig. 5, however, we have supposed  $C$  to remain stationary and have attributed all the relative movement to  $A'$ , whereas in fig. 6 we have divided the movement equally between  $A^f$  and  $C''$ ; as we do not know the actual, but only the relative, movement this difference has no significance.

What was actually determined by the two surveys were the distances of points on the line  $C^fD'$  and  $A''B''$  in fig. 5 measured from the line  $C'A'$ ; and this is equivalent in fig. 6 to the distances of the line  $C''D'$  from  $C''Q''$ , and  $A''B''$  from  $Q'A''$  less the distance  $O'Q'$ . The divergence of the lines  $A''B''$  and  $CD'$  from straight lines does not represent the strains which existed in the region just before the rupture, but only the strains accumulated before 1874-1892; we have seen that the total strains set up by 1906 are represented by the divergence from straight lines of the lines  $A''O$  and  $CO$ , or their counterparts,  $A''B''$  and  $CD''$ .

#### ILLUSTRATIVE EXPERIMENTS.

The following very simple experiments were made to illustrate the conclusions we have arrived at regarding the elastic strains and the relations between the slip at the fault-plane and the displacements of distant points. A sheet of stiff jelly about 2 cm. thick and 4 cm. wide was formed between two pieces of wood (fig. 7) to which it clung fairly well. A straight line  $AC$  was drawn on the jelly, which was then cut by a sharp knife along the line  $ttf$ ; the left piece of wood was then moved about 1 cm. parallel with  $ttf$ , as shown in fig. 8; a slight pressure on the jelly prevented slipping along the cut line; the jelly was thus subjected to an even shear thruout and the original straight line  $AC$  was distorted into the line  $A''C$ ; when the pressure on the jelly was removed, the elastic stresses set up by the distortion came into action, the two sides of the jelly slipped past each other along the line  $\ll$ ,  $A''O$  straightened out to  $A^*O$ , and  $CO$  to  $CQ$  the slip  $Q^*O''$  being equal to the distance  $AA''$ ; and all the strain in the jelly was relieved. (The difference in the straight line  $A^fOC$  in the jelly and the curved line  $A^*OC$  (fig. 6) in the rock will be explained later.)

A second straight line  $A^*CC$  was drawn across the jelly after  $A$  had been displaced, but before it was allowed to slip on the line  $ttf$ ; when the slip took place, this line broke

at  $O''$  and took the position  $A''B''$  and  $CD''$ ; the slip  $D''B''$  equaled the displacement  $AA''$ ; but the points  $A''$  and  $C''$ , of course, remained unmoved.

A third experiment was made. A line  $A'C$  (fig. 9) was drawn after the jelly had been distorted, exactly as in the last experiment; the left piece of wood was then moved 0.5 cm. further and the line was distorted into  $A''C$ ; when the jelly slipped and resumed

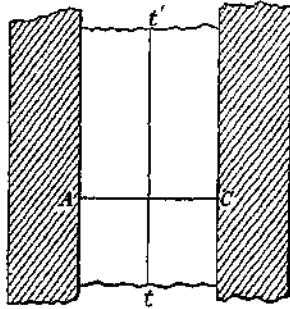

FIG. 7.

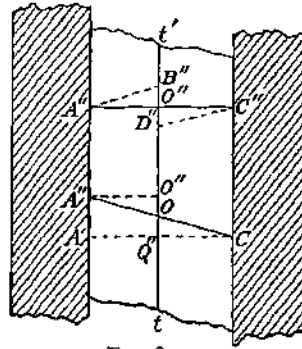

FIG. 8.

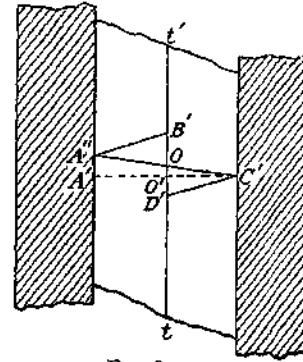

FIG. 9.

its unstrained position, the line  $A''OO$  broke into the two lines  $A''B'$  and  $CD'$ ; the slip  $D'B'$  was 1.5 cm., equal to the total displacement of the left piece of wood from its original position when the jelly was unstrained; and the distances of points on the line  $A''B'$  near the fault, measured from the line  $A'C$ , were about twice the distances from  $A'C$  of points on the line  $CD'$  at equal distances from  $tt'$ . But at a distance from  $tt'$  the displacements on the left were more than twice as great as those on the right; which agrees with the relative displacements actually observed (vol. I, p. 134). With the exception of the straightness of the lines the last experiment reproduces exactly the characteristic movements which took place at the time of the California earthquake. The letters in figs. 7, 8, and 9 correspond to those in figs. 5 and 6.

#### THE INTENSITY OF THE ELASTIC STRESSES.

The forces which caused the rupture at the fault-plane are measured by the distortion of the rock there, and if we can determine the angles which the lines  $A''O$  and  $CO$  (fig. 6) make with  $AC$  at  $O$ , we can estimate these forces; these angles can be determined approximately from the analogous angles at  $B'$  and  $D'$ . Let us determine what the latter angles are. The lines  $A''B'$  and  $C'D'$  are constructed from Dr. Hayford's summary of the results of the surveys already mentioned and have the same curvature as the lines  $A''B'$  and  $CD'$  in fig. 5; the data (vol. i, p. 133) may be collected in a table as follows:

TABLE 3. — Displacements between II and III Surveys.

No. OF POINTS.	AVERAGE DISTANCE FROM FAULT.		DISPLACEMENT BETWEEN II AND III SURVEYS.	
	East.	West.	South.	North.
	km.	km.	m.	m.
10	1.5	....	1.54	....
3	4.2	....	0.86	....
1	6.4	....	0.58	....
12	...	2.6	....	2.05
7	...	5.8	....	2.38
1	:::	37.0	....	1.78

It will be observed that three points are determined on the eastern line near enough to the fault to enable us to draw the line fairly well and to extend it to the fault at  $D'$  (fig. 5). We have but two points determined on the western line near the fault, which are not enough to determine the character of the line; but a third point is determined from the fact that  $B'$  must be about 6 meters from  $D'$ , and we can therefore draw the western line fairly well also. Its general form is like that of the eastern line, but its curvature is somewhat less. This is probably in part due to the fact that the rocks on the western side of the fault are more rigid than those on the eastern side; for former movements on this fault have raised the western side relatively to the eastern and brought the more rigid crystalline rocks nearer the surface.

In fig. 6  $B'B'' = O'O'' = 0.9$  meter, that is, half of 1.8 meters, the total relative displacement of  $A'$  and  $C''$  between the two surveys; and since  $O''B''$  is a little less than half the total slip, on account of the greater rigidity of the western rocks, we may estimate it at 2.8 meters. Therefore  $CW$  equals 1.9 meters, and  $O''B''$  is 1.47 times  $O''B'$ ; and since the curves  $A''B'$  and  $A'B''$  are both curves of elastic distortion of the same substance the angle at  $B''$  must be 1.47 times that at  $B'$ . We can measure the angles at  $B'$  in fig. 5 and we find it  $1/2,500$ ; therefore the angle at  $B''$  is  $1/1,700$ ; similarly we find the angle at  $D''$  to be  $1/1,000$ .

We can determine the force necessary to hold the two sides together before the rupture, which must exactly have equaled the stress which caused the break. The force per square centimeter is given by the expression  $ns$  where  $n$  is the coefficient of shear and  $s$  is the shear, measured by the angle at  $\theta$  or  $B''$  for the western side of the fault, or the angle at  $O$  or  $D''$  for the eastern side. We shall see further on that in the crystalline rocks below the surface the strain was somewhat greater than at the surface, so that we may assume that the angle corresponding to  $B''$  lower down may be as high as  $1/1,500$ .

The experiments of Messrs. Adams and Coker<sup>2</sup> give the value of  $n$  for granite as  $2 \times 10^{11}$  dynes per square centimeter (2,900,000 pounds per square inch); therefore the force necessary to produce the estimated distortion at the fault-plane at a short distance below the surface is  $1/1,500$  of this, or  $1.33 \times 10^8$  dynes per square centimeter (1,930 pounds per square inch). There are no very satisfactory determinations of the strength of granite under pure shear; tests made at the Watertown Arsenal<sup>3</sup> gave values ranging between about  $1.2 \times 10^{11}$  and  $1.9 \times 10^{11}$  dynes per square centimeter (between 1,700 and 2,900 pounds per square inch), but these values are apparently too small, for the specimens were subjected to tensions and compressions as well as to shear. The rock at a distance below the surface would probably have a greater resistance to shear on account of pressure upon it, and moreover it has not been subjected to the changes of temperature, etc., which the surface rocks experience, so that it probably has a strength greater than the higher figure given. We must therefore conclude that former ruptures of the fault-plane were by no means entirely healed, but that this plane was somewhat less strong than the surrounding rock and yielded to a smaller force than would have been necessary to break the solid rock. This idea is strongly supported by a comparison of the distance to which this shock and the earthquake of 1886, at Charleston, South Carolina, made themselves felt. With a fault-length of 435 km. (270 miles), the California earthquake was noticed at Winnemucca, Nevada, a distance of 550 km. (350 miles) at right angles to the fault; whereas the Charleston earthquake, with a fault-line certainly less than

<sup>1</sup> This reasoning is not perfectly rigid; the similarity of the lines  $A''B'$  depends upon the similarity of strains set up during the intervals between the I and 1% and the II and III surveys. These were probably fairly similar, as the difference between them represents the strain added between the II and III surveys which was only a fraction of the total strain at the time of the break; and the results obtained upon this assumption can not be very far wrong.

<sup>2</sup> An Investigation into the Elastic Constants of Rocks. Frank D. Adams and Ernest G. Coker, Carnegie Institution of Washington, Publication No. 46, 1900.

<sup>3</sup> Report of Tests of Metals, etc., made at the Watertown Arsenal, 1890, 1894, 1895. Washington, D.C.

40 km. (25 miles) long was felt slightly in Boston, a distance of 1,350 km. (850 miles). If we assume that the vibrations from the two disturbances had about the same periods and that a certain acceleration is necessary for a shock to be felt, we find that the amplitude of the vibration must have been about the same at Boston and at Winnemucca, for the two shocks, respectively; as the amplitude would diminish inversely as the distance for the Charleston earthquake, but much more slowly for the California earthquake on account of the length of the fault-line, the amplitude of the former disturbance must have been many times as great as that of the latter at the same distance from the origin; and the intensity must have been very many times greater per unit area of the fault-plane for the Charleston earthquake than for the California earthquake.

The above calculation of stresses applies especially to the region north of San Francisco; to the south the slip at the fault-line was, in places and perhaps for all this part of the fault, somewhat smaller. At Wright the slip on the fault-plane in the tunnel is given by the engineers as 5 feet, and the west side was shifted toward the north (vol. i, fig. 42, and pp. 111-113). This is a case of elastic rebound as at other parts of the fault. The character of the material in the tunnel and the numerous cracks in the surrounding mountain, one of which shows a relative shift opposite to that generally observed (p. 35), lead us to expect more or less irregularity in the distortion of the tunnel, which is confirmed by the figure. The greatest angle of shear must be something more than half the slip at the fault-plane divided by the distance over which the distortion is distributed; this gives  $2.5/5,150$  or  $1/2,000$ , approximately. The angle of distortion is apparently slightly less here than further north. The smaller slip in the neighborhood of Colma, a little south of San Francisco, may be due to the partial relief of strain by the earthquake of 1868; for it shows that this region was under less strain at the time of the II survey than the region further north.

#### THE WORK DONE BY THE ELASTIC STRESSES.

We can also determine the work done at the time of the rupture; it is given by the product of the force per unit area of the fault-plane multiplied by the area of the plane and by half the slip. If we take the depth of the fault at 20 km. (12.5 miles), the length at 435 km. (270 miles), the average shift at 4 meters (13 feet), and the force at  $1 \times 10^8$  dynes per square centimeter (1,450 pounds per square inch), we find for the work  $1.75 \times 10^{24}$  ergs ( $1.3 \times 10^{17}$  foot-pounds), or 130,000,000,000,000,000 foot-pounds.<sup>1</sup> This energy was stored up in the rock as potential energy of elastic strain immediately before the rupture; when the rupture occurred, it was transformed into the kinetic energy of the moving mass, into heat and into energy of vibrations; the first was soon changed into the other two. When we consider the enormous amount of potential energy suddenly set free, we are not surprised, that, in spite of the large quantity of heat which must have been developed on the fault-plane, an amount was transformed into elastic vibrations large enough to accomplish the great damage resulting from the earthquake and to shake the whole world so that seismographs, almost at the antipodes, recorded the shock.

#### THE DISTRIBUTION OF THE DEFORMING FORCES.

In examining what forces could have caused the slow displacements which brought about the strains existing in the region before the rupture, we note that gravity does not seem to have been directly active, as the displacements were practically horizontal. Any force except gravity could only have been applied to a boundary of the region

<sup>1</sup> It is probable that the maximum strain was not produced at all parts of the fault-plane, and especially not near its ends; but when the rocks broke at one place, the stress was thrown upon adjacent parts and the fracture thus carried along; in this way the fault was probably made much longer than it would otherwise have been. This consideration leads us to put the maximum stress at three-quarters the value determined from the distortion of the rock.

moved. There is no direct evidence that forces brought into play by the general compression of the earth thru cooling or otherwise were involved, for there is no evidence that the surface of the earth was diminished by the fault. It is true that the surveys did not extend over the whole length of the fault, and therefore are not decisive on this point, but so far as they went they show an extension of the region between San Francisco and Monterey Bay, between the surveys of 1851-1865 and 1906-1907.

A strong, shearing force would be produced along the fault-plane by forces making an angle in the neighborhood of  $45^\circ$  with it; that is, by either tensions or compressions in directions roughly north and south or east and west, or by a combination of the two. A tension alone could not have caused the rupture, for then the sides would have been pulled apart; an east-west compression would have brought Mount Diablo and the Farallon Islands nearer together and would have reversed the observed relative movements on opposite sides of the fault. The surveys, altho not entirely decisive, are against a north-south compression; and, moreover, the elastic distortion accompanying a compression which could produce a fracture 435 km. long would not have been restricted to a zone extending only 6 or 8 km. from the fault-plane. A shear exerted by forces parallel with the fault-plane on the eastern and western boundaries (which is equivalent to a north-south compression and an east-west tension at the boundaries) with no resistance at the under surface would have produced an even shearing strain thruout the region between them; and straight lines would have been changed into other straight lines, exactly as occurred in the experiments described above and illustrated in figs. 8 and 9. An additional compression or tension in any direction would not have altered this characteristic. Similar forces on the eastern and western boundaries with forces at the under surface resisting the movements would have produced some such distortion of the straight line  $AC$  into  $A'O$  as shown in fig. 10. The tendency to rupture would be greatest at  $A'$  and  $C''$  and least in the neighborhood of  $O$ ; it is evident that such forces could not have produced a rupture at  $O$ , and the displacements are not like the displacements observed.

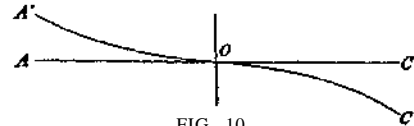

FIG. 10.

The only other boundary is the under surface of the moved region, and it is here that we must suppose the disturbing forces applied; and they must be distributed over this surface so as to produce the distortions observed.

NOTE. — Mr. Gilbert has suggested a modification of the experiments described above; instead of making the cut, which represents the fault, all the way thru the jelly, he suggested that it extend only a part way thru, and that it would thus more nearly represent the true conditions of the earthquake fault. This was tried, but the jelly was not strong enough to resist the forces developed during the displacement and the break was quickly extended all the way thru the jelly. It is not difficult, however, to see what forces would be developed under these circumstances. There are two cases: first, suppose\*there exists below the crust a region practically devoid of elasticity, in which only viscous forces can act, and suppose the fault extends to this region; we then come back to the last case considered. Second, suppose the elastic character of the rock extends well below the lower limit of the fault; such a case could easily exist if the strength of the rock increased with depth, even tho the strains continued far below the fault as great as they were within its limits. Let us consider the nature of the distortion produced in this case. We shall suppose the rock under elastic shearing strain, and when the rupture occurs, the shearing forces across the fault-plane, which upheld the strain, are annulled and the rock takes a new position of equilibrium under the new forces brought into action, in such a way that the surface line  $A'OC$  (fig. 11), straight just before the rupture, afterwards takes the position  $A'O', D'C'$ . Below the limit of the fault no change takes place, but the original vertical plane thru  $A'O'C$  has been broken and warped, suffering no displacement below the fault, but gradually increasing its distortion until it corresponds to  $AO'$  and  $D'C''$  at the surface.

An element of the surface  $a$ , on the eastern side of the fault, has been displaced to  $a'$  and a vertical line,  $a''a$ , thru  $a$  has been distorted into  $a''a'$  by an elastic shear. The forces parallel with the fault acting on the element in its new position are:

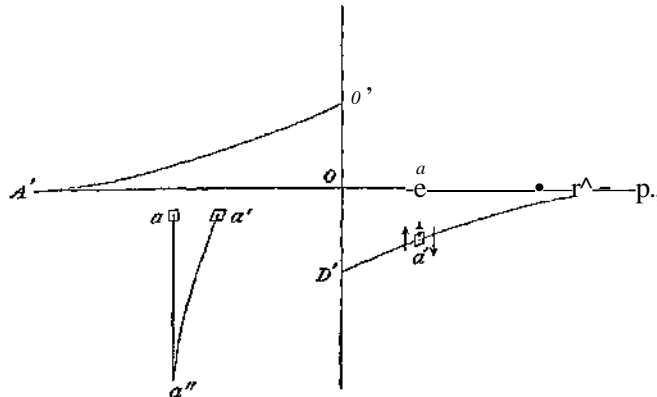

FIG. 11.

a shearing force to the southeast on its northeastern face, one to the northwest on its southwestern face, one to the northwest on its under surface due to the shear in the vertical plane; for equilibrium the sum of these must be zero, therefore the shearing force on the northeastern face must be greater than that on the southwestern; this relation holds for the whole length of the line  $D'C$ ; the shearing stresses therefore must become greater as we leave the fault-line. As the strains are proportional to the stresses, the curvature of the line  $D'C$  must become greater

the further we go from the fault, until we reach the boundary where the forces are applied. This is true whether the forces are tangential forces applied along a boundary parallel with the fault, or a general north-south compression and an east-west tension. The surveys, however, on the east side of the fault, where alone they are sufficiently complete, show that the curvature of the distorted line was greatest near the fault-line; they could not, therefore, be due to a general compression and extension nor to simple tangential forces, but the distorting forces must diminish with distance from the fault-line; this could only hold if they were applied at the under surface, which brings us back to the conclusion already reached.

Let us suppose the straight line  $WOE$  in fig. 12 to represent a line at right angles to the fault in the unstrained condition; let this line be slowly distorted by the applied forces into the full line  $WAOCE$  just before the rupture. We have heretofore only considered the region between  $A$  and  $C$ , that is, between Mount Diablo and the Farallon Islands, but we now extend our consideration to the whole region moved. It is evident that the displaced

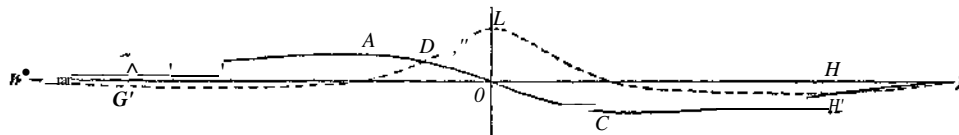

FIG. 12.

area must have some limit; the surveys only covered the region between  $A$  and  $C$ , and therefore throw no light on what occurred at greater distances from the fault. There is no reason whatever to believe that other ruptures and slips occurred outside the region between  $A$  and  $C$ ; there is a gradual diminution of the intensity of the felt disturbance as the distance from the fault increases, with the exception of the Sacramento Valley, where the slight increase is entirely accounted for by the alluvial character of the ground, thus indicating that the whole disturbance originated in the one fault. The great intensity in the San Joaquin Valley may possibly be due to a local rupture; but this lies only opposite to the southern part of the great fault and does not affect the general argument, which is especially applicable to the region north of San Francisco. We conclude therefore that the displacement gradually dies out to the west of  $A$  and to the east of  $C$ , tho it may continue for a very great distance; and we assume that the line of displacement becomes asymptotic to the undisturbed line  $WOE$  at some distant points,  $W$  and  $E$ , which would be characteristic of any displacement gradually dying out. The shearing force at any point of this line is proportional to the shear, which equals the angle at that

point which the line makes with its original unstrained direction. We have represented the value of this force by the broken line  $WG'LH'E$  in fig. 12. Starting at  $W$  where it is zero, the shearing force becomes negative; that is, it is directed in a southerly direction, reaching a negative maximum at  $G'$ , where the displacement curve has a point of inflection; it then diminishes in value, becoming zero at  $A$ , where the displacement curve is parallel with its original direction; it then increases rapidly in value, reaching a positive maximum,  $L$ , at  $O$ , the point of rupture; the shearing force to the east of the rupture has somewhat the same value it has at an equal distance to the west, tho symmetry is not required. The total shearing force which we have determined is not the force applied at each point under consideration, but is equal to the sum of all the forces applied to the east or west of the point; the actual force applied at each unit length of the line is proportional to the difference in value of the total shearing force at points a unit distance apart; that is, to the angle which the line representing the total shearing force makes with the line  $WOE$ ; it is represented by  $WGDOFHE$  in fig. 13. Starting with a zero value at  $W$ , it first has a small negative value but becomes zero again at  $G$ ; it then becomes positive and increases to a maximum at  $D$ , where the line of total shear has a point of inflection—and dies down rapidly to zero at  $O$ , where the total shear is a maximum; it has somewhat similar but opposite values to the east of  $O$ .

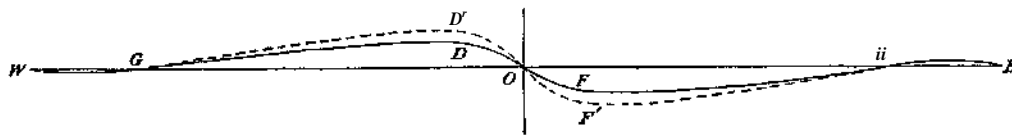

FIG. 13.

Without insisting on accuracy in small details the full line in fig. 13 shows in a general way the relative distribution of the forces, applied at the under side of the moved region, which brought about the California earthquake.

The distribution of the total shearing forces shows why in 1906 there was no break at the Haywards fault, where the break occurred which caused the earthquake of 1868. This fault is about 30 km. (18.5 miles) east of the San Andreas fault; and therefore in the neighborhood of  $C$  (fig. 12), where the surveys detected no displacement relative to Mount Diablo; in this region, as the figure shows, there was practically no shearing force, and therefore no break occurred. For the same reason there was no rupture at the San Bruno fault south of San Francisco. This fault is 4 km. (2.5 miles) east of the San Andreas fault and at that distance (fig. 5) the shearing force was only about one-third as strong as it was where the rupture actually occurred. We have seen that the elastic strain was probably accumulating for 100 years; it is quite possible, then, that the earthquake of 1868 partially relieved the strain for some distance south of San Francisco and that there would have been no fracture in this part of the San Andreas fault if additional strains had not been thrown on it by the rupture of the fault-plane further north.

It is to be noticed that the distances from  $O$  to  $A$  and from  $O$  to  $C$ , beyond which no distortion of the rocks occurred, were probably less than 10 km. (6 miles), and the distances  $OG$  and  $OH$ , over which the distorting forces were distributed, were probably ten or more times as great, and the total area over which they were applied was many times as great as the area of the fault-surface; the applied forces were therefore considerably smaller per unit area than the shearing forces at the fault; for the sum of all these forces on each side of the fault-plane must have equaled the shearing force at that plane plus the small shearing force at  $G$  or  $H$ , due to the slight reverse curving at this point.

As the dragging forces are applied at the base of the crust they have a moment about its center of gravity which is balanced by the moment due to stronger and greater shears near the bottom than near the top at the points  $G$ ,  $O$ , and  $H$  (fig. 12); and lines at differ-



ent distances below the surface which were straight and at right angles to the fault when the rock was unstrained became distorted in different degrees, the distortion from the surface downwards being somewhat as shown in fig. 14; where the three lines illustrate,

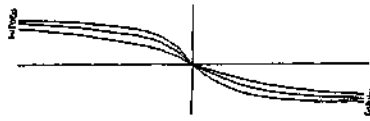

FIG. 14.

in an exaggerated way, how the distortion of straight lines varies from the surface (1) to the bottom (3). Both the shearing strain and the strength of the rock increase with the depth, but the rate of neither is known; the depth at which the rupture first occurs is the depth at which the shearing strain becomes too great for the rock to withstand. It is pretty certain that this would not be very near the surface, and also that it would not be at the lowest part of the subsequent fault, but somewhere between those two points; for, wherever the rupture began, the strain must have been increased on all sides, the fracture must have been extended downwards as well as in other directions, until the strain was generally relieved. The determination, by time observations, of the origins of the earliest disturbance and of the beginning of the heavy shock place them between the surface and a depth of 40 km. (25 miles).

#### THE DISTRIBUTION OF THE SLOW DISPLACEMENTS.

We have no information regarding the absolute displacements of the land at a distance from the fault-line; we merely know that relative displacements occurred between the surveys of 1851-1865 and 1874-1892; and also between 1874-1892 and 1906-1907. We have for the sake of simplicity assumed that the regions at a distance from the fault and

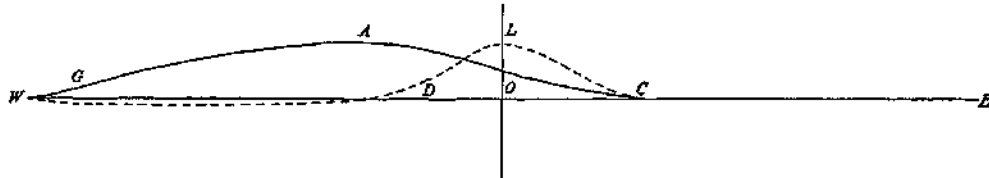

FIG. 15.

on opposite sides experienced nearly equal and opposite absolute displacements; but this is entirely unnecessary. It is possible, indeed probable, that the region on one side of the fault and at a short distance from it remained stationary, and that the slow displacements were all in one direction. The fact that the eastern side was above, and the western side below the sea-level, does not in the least indicate which side remained stationary; but the constancy in length and direction of the line from Mount Diablo to Mocho suggests that the eastern side was not displaced; for it seems improbable that, if this side had moved,

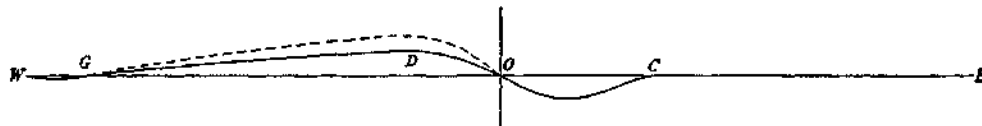

FIG. 16.

the displacements would have been so nearly alike at the points mentioned that no change could be detected in the line joining them. Under this assumption our curve of displacements takes the form of the full line in fig. 15 instead of that in fig. 12. The curvature of this line between A and C is the same as in the former case; to the east of C the line is straight, and at some point to the west of A it again reaches its unstrained position. The total shearing force (represented by the broken line in fig. 15) has practically the same values as in the former case, except that it dies out near C; and the applied forces per unit area (full line in fig. 16) do not differ materially from the former case except that they do not extend farther east than C.

## A POSSIBLE ORIGIN OF THE DEFORMING FORCES.

The reasoning so far has been strictly along dynamic lines and the results may be accepted with some confidence; but in attempting to find the origin of the forces which produced the deformation we have been studying, we pass into the region of speculation.

The theory of isostasy, which has been shown to be true on broad lines by geodetic observations, requires that there be flows of the material at some distance below the surface to readjust the equilibrium destroyed by the erosion and transportation of material at the surface. This suggests that flows below the surface may have been the origin of the forces we have been considering, for as Dr. Hayford has pointed out,<sup>1</sup> such flows would exert a drag on the material above them. The isostatic flows are the direct result of gravity and therefore easily understood, but no explanation has been found for the flows suggested as the origin of the forces in the case under consideration; nevertheless, as the forces must have been exerted at the lower surface of the moved region, it is worth while to determine the character of the flows which could have produced these forces, and leave to future observations the decision as to whether they really exist or not. Without assuming exact proportionality between the flow and the dragging force it exerts, we can say that the flow would be in the same directions as the force and would increase and decrease with it. Therefore the flow can be inferred from the diagram of forces in figs. 13 and 16. In the first case they consist of a flow to the north between  $G$  and  $O$ , and a flow to the south between  $O$  and  $H$ ; they would not be uniform, but starting with a zero value at  $G$  and  $H$ , they would increase to maxima at  $D'$  and  $F'$ , and decrease again to zero at  $O$ . The force between  $W$  and  $G$ ,  $H$  and  $E$ , would not be due to flows but would be due to the resistance to the displacement of that part of the crust by the undisturbed material below; this displacement being due to the drag of the flows nearer the fault, transmitted elastically thru the crust to these regions; this is indicated by the reversed curvature of the line of displacements in fig. 12. The principle of continuity would naturally lead us to suppose that the flows were connected beyond the northern and southern ends of the fault; these portions of the flow would be so far apart and would have so short a length in comparison with the portions flowing north or south that their effects would be relatively insignificant. It may appear that there is a suggestion here of perpetual motion, but this is not so; all steady flows are in closed circuits, and it is only in case we should disregard the necessity of a proper supply of energy, that we should fall into the fallacy of perpetual motion.

The line of demarkation between the northerly and southerly flows need not necessarily lie exactly in the fault-line, but sufficiently near it for the growing shearing force to reach the limiting strength of the rocks at that point before it did at other points; nor is it necessary to suppose that the flows remain either constant in strength or in position; the contrary seems more probable; for if, as is natural to suppose, the forces which caused the earthquakes of 1868 and 1906 were of the same general character, the region of greatest shear, that is, the boundary between the flows, must have been in the neighborhood of the Haywards fault, about 30 km. (18.5 miles) further east, in 1868. Indeed, the displacements which occurred between the first two surveys indicate a somewhat different distribution of the flow from that suggested to explain the later displacements.

At first thought we might suppose that the movement of Mount Tamalpais in opposite directions relative to Mount Diablo in the two intervals between the surveys would indicate that it was on opposite sides of the boundary during these intervals respectively, but this would not necessarily follow. During the whole time that strains were being set up all points west of  $C$  moved to the north with respect to it; this relative movement in the second interval is represented on the eastern side of the fault by the distances between the lines  $CQ^f$  and  $CQ^*$  in fig. 6; and if we consider the curves in the figure as similar

<sup>1</sup>The Geodetic Evidence of Isostasy. John F. Hayford. Proc. Washington Acad. of Sci., 1896\* vol. VII, pp. 25-40.

curves, it can be shown that these distances are a little less than four-tenths the observed distances between  $C''D'$  and  $C''Q''$ , at equal distances from the fault. The observed southerly displacement of Mount Tamalpais between 1874-1892 and 1906-1907 was 0.58 meter; its northerly displacement between 1874-1892 and the beginning of 1906 must have been about 0.22 meter; and therefore its actual southerly movement at the time of the earthquake must have been 0.8 meter; and the opposite displacements of Mount Tamalpais in the two intervals would have occurred independently of the shifting of the underground flows.

If instead of considering the displacements roughly symmetrical and in opposite directions on opposite sides of the fault-line, we prefer to consider that they were all northerly, the conditions are represented in figs. 15 and 16; they are satisfied by the supposition of a single, northerly flow extending for some distance to the west, increasing to a maximum at  $D$  and diminishing rapidly to zero in the neighborhood of  $O$  (broken line in fig. 16). The southern force between  $O$  and  $C$  would be referred to the resistance which the underlying material would offer to the displacement of the crust above it.<sup>1</sup>

---

<sup>1</sup> Mr. Bailey Willis, on account of the forms of the mountain ranges bordering the Pacific Ocean, has concluded that the bed of the ocean is spreading and crowding against the land. He thinks in particular that there is a general sub-surface flow towards the north which would produce strains and earthquakes along the western coast of North America. *Science*, 1908, vol. XXVII, p. 695.

## ON MASS-MOVEMENTS IN TECTONIC EARTHQUAKES.

---

### THE MOVEMENTS BEFORE AND DURING EARTHQUAKES.

The following is the conception of the events leading up to a tectonic earthquake and of the earth-movements which take place at the time of the rupture, as developed by the observations and study of the California earthquake and by the comparison of these observations with what has been observed in other great earthquakes.

It is impossible for rock to rupture without first being subjected to elastic strains greater than it can endure; the only imaginable ways of rapidly setting up these strains are by an explosion or by the rapid withdrawal, or accumulation, of material below a portion of the crust. Both explosions and the rapid flow of molten rock are associated with volcanic eruptions and with a class of earthquakes not under present discussion; since earthquakes occur not associated with volcanic action, we conclude that the crust, in many parts of the earth, is being slowly displaced, and the difference between displacements in neighboring regions sets up elastic strains, which may become greater than the rock can endure; a rupture then takes place and the strained rock rebounds under its own elastic stresses, until the strain is largely or wholly relieved. In the majority of cases, such as when there is a general differential elevation or depression of adjoining areas, or where there are horizontal displacements, the elastic rebounds on opposite sides of the fault are in opposite directions. The directions of the slow relative displacements on the two sides of the rupture and of the elastic rebounds, all of which are practically parallel with each other, may be vertical, horizontal, or inclined.

The sudden displacements, which occur at the time of an earthquake, are confined to a zone within a few kilometers of the fault-plane, beyond which only the disturbances due to elastic vibrations are experienced. The distribution of the distortion of the rock at the time of the California earthquake shows that the elastic rebound and consequently the elastic shear was greatly concentrated near the fault-plane and was much reduced in intensity at even short distances from it; this concentration of the shear brought about a strain sufficient to cause rupture after a comparatively small relative displacement of the surrounding regions; if the shear had been more uniformly distributed over a wider region, a larger relative displacement would have been necessary to cause a rupture and there would have been a greater slip at the fault-plane. Therefore, altho it is quite conceivable that regions at a distance apart of, let us say, several times 20 km., might be relatively displaced and set up a state of elastic strain in the broad intervening area, it would be necessary that the relative displacements of the distant regions should be at least several times 6 meters, in order that the strain should become great enough to cause a rupture; and if the strain were less concentrated than it was in California, the relative displacements would have to be greater still. It is only in the case of very large earthquakes that a slip as great as 6 meters occurs; and we may therefore infer that it is only in the case of large earthquakes that the sudden elastic rebound is appreciable as far as 8 or 10 km. from the fault-plane.

The rupture does not occur simultaneously at all parts of the fault-plane; but, on account of the elastic qualities of the rock, it begins in a very limited area and spreads at a rate not exceeding the velocity of compressional waves in the rock.

We should expect that the slow accumulation of strain would, in general, reach a maximum value and bring about a rupture in a single, comparatively narrow fault-zone; and this is probably what occurs for the majority of tectonic earthquakes, but it is quite conceivable that the strains should become so great along two or more separated zones, that the vibrations, set up by the rupture of one, might be sufficient to begin the rupture of the second; or indeed, that the relief of strain at one might cause additional strain at the other and thus start the rupture there, tho this seems improbable if they are as much as 20 or 30 km. apart. But it does not seem possible that large blocks of the earth's crust could be suddenly moved as a whole; if the material under the block slowly sank, the elasticity of the rock would allow the block to follow, still resting upon the substratum, and only a zone between the sinking area and the surrounding regions would be elastically strained and experience a sudden elastic rebound when the rupture occurred; and if the sinking area were large, the irregularity of the movement would probably bring about ruptures on different sides at widely different times. If a limited region should be elevated, exactly the opposite movements would take place. It must not be inferred, from what has been said, that small narrow blocks, from a few meters to a few kilometers in width, may not be raised or dropt as a whole, but they should be lookt upon as small blocks, forming a part of a single fault-zone and playing a very minor part in the general disturbance of the earthquake.

The Mino-Owari earthquake of 1891, the Formosan earthquake of 1906, and the California earthquake of 1906 are good cases of earthquakes practically with a single fault-zone; whereas, the great earthquake in the central part of Japan in 1896 resulted from fractures along two roughly parallel fault-planes 15 to 18 km. apart, and the intervening region was elevated 1 to 3 meters; one of the fractures was considerably longer than the other; and there is no evidence of any connecting fractures, which would separate the elevated region into a block; the faults apparently die out, as faults usually do, and the elevation diminishes towards their ends and finally disappears completely. The two fractures occurred at about the same time, but no determinations were made exact enough to show that they occurred simultaneously. The sharply defined areas in Iceland over which the earthquakes of 1896 were severally felt suggest that they were due to the settling of successive blocks, and this idea is strengthened by the fact that theregion is deprest and separated from the higher adjacent region by a fault. But the description given by Dr. Thoroddsen<sup>1</sup> does not indicate that the individual areas mentioned are bounded by faults, nor does he adduce any evidence that they sank at the time of the shocks, tho he does describe some large fissures which ran across several of them. Iceland is actively volcanic, and the descriptions of it suggest a very mobile condition not far below the surface. If this condition really exists, it would be much easier for cracks to form at approximately the same time and break up the crust into blocks there than in regions where the crust rests on a firmer foundation.

The elevations and depressions about Yakutat Bay, Alaska, which Messrs. Tarr and Martin have described as due to the earthquake of 1899, strongly suggest the movement of blocks;<sup>2</sup> but they did not find evidences of faultings on more than three sides of a block, and that in only one instance; tho it must be noted that they were unable to examine more than a very limited area and could not determine where the lines of fracture ended. It seems possible that the displacements they describe might be accounted for by an upward pressure, with or without a compression in a direction running north-northwest and south-southeast. Such a pressure and compression would bend the rocks into an arch, with the surface under tension, and the rupture would occur when this tension reached the limiting strength of the rock; the rupture would begin at the surface and

---

<sup>1</sup> Das Erdbeben in Island im Jahre, 1896. Petermann's Mitt. 1901, vol. XLVII, pp. 53-56.

<sup>2</sup> Recent Changes of Level in the Yakutat Bay Region, Alaska. Bull. Geol. Soc. Amer. 1906, vol. xvii, pp. 29-64.

extend downwards, and the ends of the broken rock would fly upwards, just as do the ends of a stick broken by bending, and an open fissure would be formed at the principal fracture; but along the side cracks the relative elastic rebounds might be in opposite directions and the parts might remain in contact. The principal fracture would be that in Disenchantment Bay, but no soundings have been made there to discover the existence of a fissure. Fissures and displacements of this character, due probably merely to compression, but on a very small scale, have been described.<sup>1</sup>

We know very little about the interior of the earth or of the origin of the forces which produce such great changes at the surface. Great thrust faults exist which indicate tangential compressions; and normal faults, which indicate expansion. Great uplifts have occurred unaccompanied by compressions, due, apparently, to vertical forces; and the California earthquake has emphasized the existence of horizontal drags below the crust. Future study may reveal forces applied in other ways; but it is not going too far to say that whenever ruptures occur, they result from elastic strain, and the sudden movements produced are merely elastic rebounds; and moreover, except in the case of earthquakes connected directly with volcanic action, the strains have not been set up suddenly, but are gradually developed by the slow displacements of adjacent areas. And severe earthquakes caused by shearing strains, vertical, horizontal, or oblique, where the elastic rebounds are in opposite directions on opposite sides of the fault, which remain in contact, will be more common than those due to the tensional strains of bending, where the elastic rebounds are in the same direction and a gaping fissure is opened.

#### THE PREDICTION OF EARTHQUAKES.

As strains always precede the rupture and as the strains are sufficiently great to be easily detected before the rupture occurs, in order to foresee tectonic earthquakes it is merely necessary to devise a method of determining the existence of the strains; and the rupture will in general occur in the neighborhood of the line where the strains are greatest, or along an older fault-line where the rock is weakest. To measure the growth of strains, we should build a line of piers, say a kilometer apart, at right angles to the direction which a geological examination of the region, or past experience, indicates the fault will take when the rupture occurs; a careful determination from time to time, of the directions of the lines joining successive piers, their differences of level, and the exact distance between them, would reveal any strains which might be developing along the region the line of piers crosses. In the case of vertical, horizontal, or oblique shears, if the surface becomes strained thru an angle of about  $1/2000$ , we should expect a strong shock. It would be necessary to start with the rock in an unstrained condition; this could readily be done now in the neighborhood of the San Andreas fault. The monuments set up close to the fault-line (vol. I, pp. 152-159) were not placed with this object in view, but with the object of measuring actual slips on the old fault-line. Measures of the class described would be extremely useful, not only for the purpose of prediction, but also to reveal the nature of the earth-movements taking place, and thus lead to a better understanding of the causes of earthquakes. Less definite, but still valuable, information could be obtained by the simpler process of determining, from time to time, the absolute directions of Farallon Light-house and Mount Diablo from Mount Tamalpais; by this means northerly or southerly movements of 1 foot of either of the first two stations relative to the third could be detected; and we should know if strains were being set up in the intermediate region; but we could not tell where the strain was a maximum nor to what extent it may have been relieved by small displacements on intervening fault-planes.

---

<sup>1</sup> F. Cramer, Am. Jr. SeL, 3d Series, 1890, vol. xxxix, pp. 220-225; and 1891, vol. xi\*, pp. 482-434. Mr. H. P. Gushing has shown me pictures of similar cracks with elevated lips in central New York.

It seems probable that a very long period will elapse before another important earthquake occurs along that part of the San Andreas rift which broke in 1906; for we have seen that the strains causing the slip were probably accumulating for 100 years. There have been no serious earthquakes reported along this part of the rift, except at its southern extremity, since the country has been occupied by white men, altho strong earthquakes have occurred in neighboring regions. It seems probable that more consistent results might be obtained regarding the periodicity of earthquakes if only the earthquakes occurring at exactly the same place were considered in the series. The Messina earthquake of December 28, 1908, seems to have resulted from a movement on the great fault passing thru the Straits of Messina. The last strong movement at the same place seems to have occurred in 1783; tho the Calabrian earthquake of 1905 may have been caused by a movement on another part of the same fault.

It is quite possible, however, for strong earthquakes to occur on neighboring faults after short intervals. The ruptures of the Haywards fault in 1868 and of the San Andreas fault in 1906 are a fair example, tho the interval is rather long. The Iceland earthquakes of 1896, already referred to, illustrate this much better. Five strong shocks occurred within fifteen days; but they were central, not in the same region, but in regions successively more and more to the west.

When a rupture occurs, the elastic rebound may carry the sides of the fault beyond their positions of no strain, and the friction may temporarily hold them there; or the friction may be so great that they do not entirely reach these positions. In either case further shocks may be expected before long; but they are apt to be slight, and are more likely to constitute *after-shocks* than independent earthquakes.

## SHEARING MOVEMENTS IN THE FAULT-ZONE.

### CHANGES IN THE LENGTH OF LINES.

In the general descriptions of the fault-trace it is shown that when the rupture occurred there was a zone of varying width between the shifting sides which did not partake of their simple movements, but was more or less distorted by the shearing forces to which it was subjected. The existence of this zone in alluvium or disintegrated rock may be explained even tho the fault were a sharply defined crack in the underlying solid rock. Let us suppose that the straight line  $AOC$  in the rock (fig. 17) has been broken at the fault and displaced into the two parts  $A'O'$  and  $D'C$ . If the alluvium were brittle and with little plasticity, it might be broken and displaced in the same way, but if it were plastic, as it would be if it were to some extent composed of clay, a part of the displacement would be accomplished by shearing distortion, and the offset at the fault-plane would be less than that of the underlying rock. Close to the rock the displacement of the alluvium would be very nearly the same as that of the rock (lines 1 in the figure); at greater distances, however, the distortion in the vertical plane would make itself felt; the offset would be less, and the displacement would be distributed more like the lines 2. The alluvium might be so thick or plastic that it would suffer no break at the surface along the fault-line, the whole displacement being distributed like line 3; this seems to be the condition which produces the *echelon phase* of the fault-trace in very wet alluvium, as described by Mr. Gilbert (vol. i, p. 66).

Special phenomena were exhibited in this zone of shearing distortion which might easily be misunderstood, but which can be explained fully on mechanical principles.

The zone was in some places only 2 to 6 feet wide, in others several hundred yards. Where it was broad the shift was divided in some cases among a number of cracks; in others it was distributed more or less evenly over the zone; in all cases, we have a zone of greater or less width subjected to shear; let us see what compressions and extensions take place in it. Let  $W$  and  $E$  (fig. 18) be the eastern and western boundaries of the sheared zone, whose width is  $I$  and let  $W$  move a distance  $s$ , short in comparison with  $I$ ; and let all other lines parallel with the boundaries also move a distance proportional to their distance from  $E$ .  $WN$  will be the direction of this motion;

the line  $Ec$ , which makes an angle  $a$  with  $WN$ ,  $a$  being positive to the right of  $WN$ , is shortened by an amount  $cd$ ; and the simple geometry of the figure shows that the total shortening equals  $s \cos a$ ; and this is independent of the length  $Ec$ , provided only that the line  $Ec$  does not materially change its direction during the motion.; this is, in general,

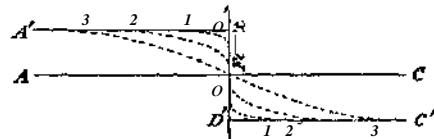

FIG. 17.

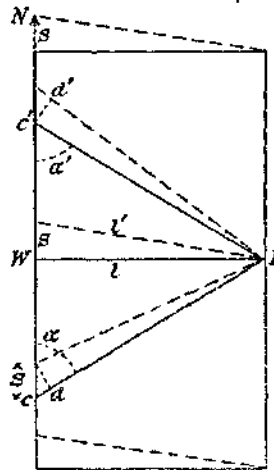

FIG. 18.

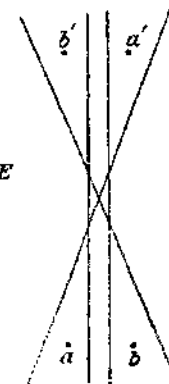

FIG. 19.



them would trend about north and south, as the fault runs about northwest. The subsequent movement seems in many places not to have obliterated this arrangement of the turf in strips, which is so characteristic that it indicates the position of a fault-trace without possibility of error, and shows the direction, tho not the amount, of the relative movement of the sides. Its appearance is shown in plates 16B, 39B, 43B, and it is sketched diagrammatically in figs. 18, 19, 20, vol. i.<sup>1</sup> An interesting example is shown in plate 65A and fig. 57, representing an auxiliary fault at the Morrell ranch; the direction of the diagonal cracks across the road shows that the northeastern side moved relatively to the northwest, a direction contrary to the movement observed elsewhere. This unexpected result is confirmed by the offsets of the fences bordering the road; a picture of the right-hand fence is shown in plate 64B, and a measure of the offset shows a relative movement of 3.75 feet. This anomaly is local and apparently very superficial, as it does not appear in the tunnel which is nearly under the point observed; the tunnel is offset normally a short distance to the east of the auxiliary fault.<sup>2</sup>

In places the subsequent motion has so broken up and so confused the earth clods that the regular diagonal cracks have been obscured; in places a slight compression or extension at right angles to the fault has entirely closed the cracks or made others more nearly parallel with the fault; but it is surprising how generally traces of the diagonal cracks can be seen when they are lookt for. They are frequently described by the word *splintering*.

If the sheared zone runs along a slope, gravity acts as a tension on the higher part of the zone, increasing the tendency to form cracks and making them more nearly parallel with the fault-trace; in the lower part it produces a compression which tends to prevent the formation of cracks. This is the condition near San Andreas Lake (vol. i, p. 93).

Other cracks were made which apparently were not due to the shearing movements in alluvium which we have been considering; some, such as those in the Point Reyes region and those on Black Mountain (vol. 1, pp. 75, 107) seem due to a general shattering of the mass, and may be caused by vibratory motion (vol. n, p. 40); others (vol. 1, pp. 106-109) which are nearly parallel with the fault may in some cases be due to the topography, and in others to a small relative upthrust of one side of the crack.

In all parts of this report special efforts have been made to distinguish between cracks and dislocations due to the actual rupture along the fault, and those due to landslides, the settling of unconsolidated material, the slumping of river banks, the effects of vibrations, etc. This distinction is very important in order to interpret correctly the true movements of the underlying rock.

#### OFFSETS OF FENCES AND PIPES.

The distribution of shear over a broad zone is well illustrated by the distortion of fences; a number have been described in the preceding pages and illustrated by photographs and figures; we may refer especially to figs. 15, 31, 32, vol. 1. In some oases anomalies occur, which are probably not real, but which may be due to a misinterpretation of the observations; in fig. 29, for instance, the fence on both sides of the fault-line is dragged in the same direction, with shifts of 13 feet and 5 feet 9 inches on the two sides, respectively; at a distance from the fault-line there is only a very small, relative displacement of the opposite sides; this is so opposed to the general character of the displacements that it probably does not represent the true movements. In fig. 38 a fence is represented as having been distorted to the south on the eastern side of the fault, for

<sup>1</sup> Professor Omori describes and explains this effect of the shear in his account of the earthquake of 1906, Bull. Imperial Earthquake Investigation Commission, vol. 1, No. 1, pp. 12-15.

<sup>2</sup> See Johnson's description, vol. i, top of page 277. Fig. 57 *m* badly drawn and shows the fence in the wrong direction.

a length of about 1,800 feet.

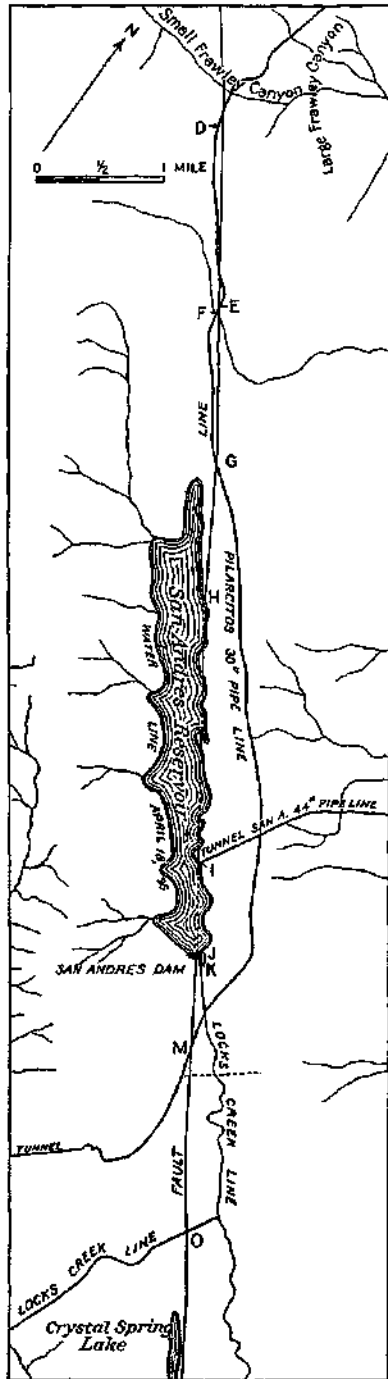

FIG. 22.

The pipe again crosses the fault near the head of San Andreas Lake, from right to left (*G*), and was pulled apart in two places a total of 6 feet 8 inches (plate 59A); this, with an offset of 6 inches, indicates that the angle between the pipe and the fault was but  $3.5^\circ$ .

There is no evidence that the zone of distributed shear had such a breadth in this neighborhood, and moreover the displacement of the fence is in the wrong direction to be explained by this means. Nor can we refer it to elastic rebound as described on pages 17-20 for the angle of shear would be more than 1/500 or about 7 minutes of arc, which is much greater than can be allowed. The displacements of the fence are measured from its inferred original position supposed to be a straight line, but we are not informed how the original position was determined. It would not be permissible to infer its direction from the continuation of the fence outside the eastern stone monument; and if the records of the original surveys gives the magnetic direction of the line, an imperfect knowledge of the magnetic declination and instrumental errors (if the line was run with a compass) would easily account for the deviation of 7 minutes between the present line and its supposed original direction. It seems probable therefore that the true distortion was confined to a comparatively short length of the fence. There seems no clear explanation of the bow-shaped distortion of the fence in fig. 34, unless the fence originally had this shape.

The Pilarcitos 30-inch wrought-iron pipe of the Spring Valley Water Company runs near the fault for a distance of two miles northwest of San Andreas Lake and crosses it four times (vol. i, p. 95). The map (fig. 22), taken from the report of Mr. H. Schiessler, chief engineer of the company, shows the location of this and of some other pipes of the company. Beginning at the northwest the pipe crosses from left to right at Small Frawley Canyon, and the angle between the pipe and the fault-line is  $20^\circ$ ; the shortening of the pipe is 7 feet 3 inches, and the offset is 15 inches, corresponding to a total shift of 8 feet, as determined by the formula on page 34.

We have no information about the break at the next crossing, from right to left, and about a mile distant; the pipe runs nearly parallel with, and close to, the fault between these crossings and suffered many ruptures; in one place it completely collapsed.

At the next crossing (*F*), very near the last, the pipe crossed from left to right at an angle of  $15^\circ$ ; it was crushed in three places, the total shortening being 9 feet 8 inches (plate 59B and p. 96, vol. i); this corresponds to a shift of 10 feet.

A half mile southeast of San Andreas Lake the pipe crosses the fault for the last time (*M*), from left to right at an angle of  $65^\circ$  (vol. i, p. 100); it was crushed and shortened 22 inches; 100 feet to the north it was crushed again, the compression there being 1 foot. The total shortening, 2 feet 10 inches, corresponds to a shift 6.75 feet; as the shift at the fault-line was only 20 inches, a part of the shear must have been distributed.

Near the northwestern end of Crystal Springs Lake the 44-inch Locks Creek pipe crosses the fault-zone from left to right at an angle of  $65^\circ$  (fig. 22, *O*, and vol. i, p. 101, fig. 39); it was crushed at four points, and pulled apart 3 inches at one point; the total shortening was 59.25 inches; this corresponds to a total shift of 11 feet 8 inches, the greater part of which was distributed.

The shifts indicated by the changes in length of the pipes must be looked upon in many cases as smaller than the true shift, for many other ruptures occurred, which are noted in the report of the chief engineer of the water company, but of which no details have been given.

#### EFFECTS ON OTHER STRUCTURES.

The two best examples of combined shortening and stretching are furnished by the gate-well on the shore of San Andreas Lake and by the flume and the waste-weir at the southeastern end of the lake; they show the existence, at the same place, of shortening and stretching in different directions, altho there is no indication of a compression or extension at right angles to the fault. The gate-well was stretched in a direction N.  $79^\circ$  W. and shortened at right angles to the stretching (vol. i, pp. 98, 99, fig. 35). The direction of the fault-trace is about N.  $35^\circ$  W., so that the directions of greatest stretching and shortening make angles of practically  $45^\circ$  with the directions of the fault. From the scale of the figure the stretching is found to be 3 feet 4 inches, which corresponds to a shift of 4 feet 8 inches. This is less than the shift in this part of the fault and confirms the evidence, furnished by cracks in the ground, that the shear was distributed over a greater width than 18 feet, the projection of the diameter of the well (25 feet) in the direction of greatest stretching upon a line at right angles to the fault-trace.

The Locks Creek flume, a 44-inch wrought-iron pipe, crosses a part of the sheared zone from right to left at an angle of  $15^\circ$  (vol. I, pp. 99, 100; fig. 36); it was pulled apart 4 feet, corresponding to a shift of 4 feet 2 inches. If the pipe had entirely crossed the sheared zone, it would have indicated a greater shift, which could not have been less than 7 feet at this point, according to the displacement of a fence shown in the same figure; the flume passes thru a concrete culvert and continues to San Andreas Lake; as this part of the pipe and culvert were parallel with the direction of the shear, they were uninjured. 275 feet from the break in the flume a strongly built brick waste-weir tunnel crosses the sheared zone from left to right at an angle of about  $57^\circ$ ; its great strength prevented it from being entirely destroyed, but it was crushed at the fault-line and shortened, tho the amount was not measured.

The examples given show very clearly that the shortening and stretching of lines in the fault-zone was not due to any general expansion or compression causing changes of area, but to shear; and the character and amount of change in length of any particular line depended on the direction in which it crossed the fault-zone and the angle it made with the direction of shift; so that, in some instances, of two lines crossing the fault-zone at the same point but from opposite sides, one was lengthened and the other shortened. It is quite possible that there were, in places near the surface, slight expansions or compression at right angles to the fault-line. As pointed out (vol. i, p. 73) the fault-plane can not be considered a mathematical plane, and the movement must have caused a slight separation of the sides in places near the surface, which may be indicated by the trench-form of the fault-trace. It is difficult to understand how the two sides of the

fault could be made to approach each other in the region of solid rock at a distance below the surface, but it is quite possible that the more unconsolidated material near the surface might be shaken together by the earthquake. ^An illustration of this may perhaps be found in the compression of the fence and the sagging of the telephone wire which cross the causeway dam between the Crystal Spring Lakes, approximately at right angles to the fault (vol. I, p. 102).

The shortening of the railway track by 7 inches between Wright and Alma (vol. I, p. 110), a distance of 5 miles, can hardly be referred to distributed shear; the track has many curves and runs in places by the sides of steep mountain slopes; and a slight shaking down of the roadbed in places might straighten the track sufficiently to shorten it by this small amount.

## VIBRATORY MOVEMENTS AND THEIR EFFECTS.

---

### CHARACTER OF THE MOVEMENTS.

When the rupture occurred on the fault-plane, it is probable that the movement did not begin at the same moment at all parts of the plane; it probably started in some limited region, and the stress, being relieved by the break there, was concentrated upon nearby points which gave way, and thus the rupture spread from point to point until it extended over the whole fault-plane; and it is also probable that the whole movement at any point did not take place at once, but that it proceeded by very irregular steps.

We can determine roughly the time which would have been required for the rock to come back to its natural position of equilibrium if it had vibrated freely without friction. The period of vibration of the rock, distorted by simple shear, as explained on page 50, is given by the expression  $T_0 = 4H\sqrt{p/n}$ ; where  $H$ , the distance from the fault-plane to which the distortion extends, may be taken as 6 km. (3.7 miles),  $p$  is the density of the rock, say, 2.6; and  $n$  is the coefficient of rigidity, say  $2 \times 10^{10}$  dynes per square centimeter (2,900,000 pounds per square inch).<sup>1</sup> With these values of the constants we find the total period to be about 8.7 seconds, or the time for the rock to move from its original displacement to its position of equilibrium one-fourth of this, or 2.2 seconds. This is found from the equation of the free vibration of the rock, in which case the straight line at right angles to the fault is distorted so as to be concave toward its position of equilibrium; but the observations in fig. 5 (page 16) show that the rock was distorted with the convex side toward the position of equilibrium. If therefore the break had been sharp, with no friction at the fault-plane, we should have had vibrations containing higher harmonics, so that the rock at the fault-plane would have made rapid but short vibrations back and forth during the 2.2 seconds necessary for it to reach the equilibrium position. This, however, was not what actually occurred; small slips took place at different parts of the fault-plane, and as the results of these successive slips and the great friction, some 30 to 60 seconds were required before the rock came to rest; and even then certain parts of the rock were apparently still held in a strained condition by strong friction, and from time to time gave way, producing the aftershocks which are listed in another part of the report.

The more or less sudden starting and stopping of the movement and the friction gave rise to the vibrations which were propagated to a distance. The sudden starting of the motion would produce vibrations just as would its sudden stopping; and vibrations are set up by the friction of the moving rock, exactly as the vibrations of a violin string are caused by the friction of the bow; the string vibrates altho the bow is drawn steadily across it; or as vibrations are set up in a finger-bowl when a wet finger is drawn along the edge; in this case we can see the vibrations transmitted to the water in the bowl.

Vibrations once started are propagated as elastic waves in the rock and consist in general of compressional waves like simple waves of sound, in which the vibratory movement of any particle is in the direction of propagation; and of transverse waves like those of light, in which the movement of the vibrating particle is at right angles to the direction of propagation. As a compressional wave advances, the mass of rock thru which it passes is subjected to successive compressions and extensions.

---

<sup>1</sup> See p. 21.

## CRACKS FORMED IN THE GROUND AND THE BREAKING OF PIPES.

We can readily determine the amount of compression and extension that takes place; the movement of an earth particle is given by the expression

$$y = A \cos 2\pi \left( \frac{t}{P} - \frac{x}{\lambda} \right)$$

where  $A$  is the amplitude,  $P$  the period,  $X$  the wave-length,  $t$  the time, and  $x$  the distance, measured in the direction of propagation; the compression and extension is given by

$$\frac{dy}{dx} = -\frac{2\pi A}{X} \sin 2\pi \left( \frac{t}{P} - \frac{x}{X} \right)$$

and its maximum value is  $2\pi A/X$ . For a wave whose period is a half second and whose velocity is 4 miles a second,  $X$  would be 2 miles or say 10,500 feet, and if  $A$  were 0.2 of a foot, the wave would cause successive compressions and expansions of short lengths of rock amounting to 1: 8350 of the length. If  $c$  is the compression or expansion per unit length and  $M$  the modulus of elasticity, which for granite with a free upper surface would be about 7.66 million pounds per square inch, the force exerted is  $cM$ , or, in the case of the above wave,  $\frac{7.66 \times 10^6}{8350}$ , or 920 pounds per square inch. This is much less than the force necessary to break granite by crushing (6 to 10 tons per square inch), but the strength of granite under tension must be less than under compression, altho its value is not known.

Cast-iron, which resembles granite in its general structure, requires four or five times as large a force to break it by crushing as by stretching; it therefore seems possible that the numerous cracks observed in the region west of Point Reyes station may be due to the vibrations. In the case of vibrations passing thru alluvium or decomposed rock, the wave-length will be shorter, the amplitude greater, and the breaking strength much less in comparison with the modulus of elasticity; so that we should expect in places, where the condition of the ground is favorable, even at a distance from the earthquake's origin, that cracks would open and close at right angles to the direction of propagation; it is to this cause we must refer the opening of cracks and the projection of water, mud, and sand into the air, which has frequently been described in connection with strong earthquakes. This phenomenon was seen in the neighborhood of Salinas (vol. I, p. 245). In very unconsolidated deposits cracks may be left open by the compression of the intervening material and water arising in the cracks may form craterlets (vol. I, pp. 229, 231, 338); but cracks formed by slumping of the ground, altho started by the vibrations, are practically due to gravity.

Pipes in the ground were subjected to similar compressions and extensions, the measure of the force being  $Ec$ , where  $E$  is Young's modulus for the material of the pipe. For cast-iron  $E$  is about 5,000 tons to the square inch and with an extension of 1: 8,350, the force tending to rupture it would be about 0.6 ton to the square inch. For wrought-iron  $E$  is about 13,000 tons to the square inch and the force developed by the above expansion would be 1.6 tons; it requires from 20 to 28 tons to break wrought-iron by tension, and 16 to 20 tons by crushing; but at the joints the pipes are weaker. On the whole, not many pipes in the ground were broken by the vibrations, tho the stronger vibrations in alluvial soil must have broken a number. A very good example is the pipe near Salinas (vol. i, p. 245), which was broken in many places; in some places the ends were separated as much as 3 feet, in others they overlapt as much as 4 feet; and they showed that they had been hammered together and had not simply been pulled apart. A pipe seen near Alvarado had had the same experience (vol. i, p. 305).

In the calculations above we have supposed the pipe so firmly embedded in the surrounding earth that it moves with the earth; under this supposition the strength of the pipe to resist rupture due to vibrations would not be changed by altering the thickness of the pipe; but if the pipe slips in the ground, as it might if it were very straight for distances of half a wave-length or more, it might be strengthened by making it thicker; but it is hardly practicable to lay pipes straight for such distances, and therefore we should not seek to strengthen pipes in the ground by making them thicker; but they would be strengthened by selecting a material with a large ratio of its breaking strength to its Young's modulus. Wrought-iron pipes would yield by crushing rather than by tension, whereas cast-iron would yield first by tension; but it would require a stronger vibration to pull apart a cast-iron pipe than to crush one of wrought-iron. In general, however, the joints are the weakest spots and the ruptures occur there.

The Spring Valley Water Company sends water to San Francisco thru three pipes (map No. 21, and fig. 22). The San Andreas pipe draws directly from the lake of the same name; altho it starts at the fault-line it was ruptured at one place only, where it crosses a marsh at Baden Station on a trestle. The pipe here was weakened by an extension joint, the two ends being held together by wires passing over lugs on the pipes; these lugs were pulled out. The lack of injury to the pipe at other places shows that, where buried in the ground, it was quite strong enough to stand the compressions and extensions due to the vibrations, and makes it probable that the many injuries received by the two other pipes, not along the fault-line, and of which we have no details, were due to some special causes of weakness at the points where they occurred. When the pipe was buried, it was prevented from bending and was then strong enough to remain-intact, but where it was carried on a high trestle, or on a trestle over a soft marsh, bending was possible and its power of resistance was similar to that of a column under compression; as is well known, a column yields, not by crushing, but by bending.

The Pilarcitos 30-inch wrought-iron pipe is carried across Large Frawley Canyon on a high trestle about half a mile east of the fault (plate 100A); the pipe is buried on each side of the canyon, the intervening length being 100 feet; this portion was broken into two pieces of practically equal lengths which, together with the greater part of the trestle, were thrown into the canyon and left side by side, 50 or 60 feet from their original position. The ruptures occurred at riveted joints, the two pieces being otherwise intact. It is clear that the portion of the pipe on the trestle must have acted like a column with fixt ends. The formula which most accurately represents the strength under these conditions is known as Rankine's formula,<sup>1</sup> and is

$$p = \frac{f}{cL^2/k^2},$$

where  $p$  is the pressure in tons per square inch necessary to cause the collapse, and  $f$  and  $c$  are constants, the first dependent upon the material of the column only, the second both upon the material and upon the character of the ends;  $L$  is the length of the column and  $k$  is the radius of gyration of the cross-section. For wrought-iron  $f$  is 16 tons per square inch;  $c$  is 1: 36,000 for a pipe with fixt ends;  $k^2 = \frac{d^2}{8}$ , where  $d$  is the average of the inside and outside diameters; so that the formula becomes

$$p = \frac{16}{1 + \frac{1}{4500} \left(\frac{L}{d}\right)^2}.$$

The length of the pipe over Large Frawley Canyon is 100 feet and the diameter 2.5 feet, therefore  $\left(\frac{L}{d}\right)$  is 40, and  $p$  the pressure necessary to break it, become 11.5 tons per

<sup>1</sup> Swing's Strength of Materials, p. 178.

square inch. The compressive force due to the vibrations calculated in the example we have used (with Young's modulus for wrought-iron equaling 28,000,000 pounds per square inch) is only about one-eighth as great, but at this short distance from the fault-plane it is possible that the vibrations may have been greater, and without doubt, the pipe itself, on account of the joints, would give way under a much smaller pressure than is required by the above formula; we must believe that the pipe yielded like a column under compression, and the sudden removal of the resistance when the rupture came allowed the elastic forces to throw the pieces 50 or 60 feet to the side.

The Crystal Spring 44-inch pipe suffered in the same way where it crossed the San Bruno marsh near South San Francisco and the Guadeloupe and Visitacion marshes a little further north. The trestle which carried the pipe over these marshes was built on deeply driven piles. The pipe was broken in many places and the pieces flung 4 or 5 feet to right and left; the trestle was also demolished, but the piling and its capping were in general uninjured. In some instances, however, the pipe seems to have been raised into the air and to have come down with sufficient force to destroy the trestle and crush the heavy timbers bolted to the tops of the piles. Altho the vibrations in these marshes must have been very violent, it was found after the earthquake that no permanent displacement had taken place; the piling had not lost its alignment nor its grade.

It does not seem probable that the lateral vibration was strong enough to break the pipe and throw the pieces 4 or 5 feet; the pipe must have been quite flexible enough to yield to such vibrations without breaking; nor is it probable that the vertical vibration was strong enough to throw the pipe upwards; it is most probable that we have here again to do with compressional vibrations, acting upon parts of the pipe as upon columns with round ends, for the ends of the short lengths of the pipe, over which the compression was strongest, were practically free to turn the small amount required. We suppose the vibrations to be communicated to the pipe thru the trestle and to be transmitted along the pipe as forced vibrations, with the same period and velocity, and therefore with the same wave-length, as in the underlying marsh; but there would undoubtedly be propagated in the pipe vibrations having a velocity appropriate to the material of the pipe, and these would in places combine with the forced vibrations, to produce unusually large forces of compression and tension.

Rankine's formula for the yielding of columns with round ends becomes

$$p = \frac{16}{1 + \frac{4}{4500} \left(\frac{L}{d}\right)^2}$$

With a 44-inch pipe  $L/d$  would be 40 for a length of about 150 feet, and  $p$ , the force necessary for collapse, then becomes 6.6 tons per square inch; which is about 4 times the pressure calculated in the example we have taken above; but in the marshes the wave-length would be greatly reduced, and there seems no difficulty in believing that the compressions were in places sufficient to break the pipe regarded as a column with rounded ends (especially at the joints), and then to fling the pieces to the side. Where the pipe had a slight bend in the vertical plane, the compression would throw it up rather than to the side, and in this way its subsequent blow upon the support is made clear. One piece of pipe, about 800 feet long, was found lying on the ground by the broken trestle uninjured except at its ends; it must have rolled off the trestle after the supporting sides had been battered off.

The San Bruno marsh is about 2 miles from the fault-line and the other two marshes about twice as far. The increase in intensity of vibration due to the character of the foundation far more than made up for the diminished intensity due to distance, as shown by the distribution of isoseismals on map No. 23.



## CRACKS IN WALLS AND CHIMNEYS.

In Mallet's great report on the Neapolitan earthquake of 1857 he assumed that the waves were propagated thru buildings just as thru the earth below, and concluded that the cracks made in the walls were at right angles to the direction of propagation of the waves. From this he deduced the direction of propagation and the position of the focus. But the length of buildings is only a very small fraction of the length of a seismic wave; and in them the proper conditions for the rectilinear propagation of waves do not exist; so that Mallet's assumption and his conclusions can no longer be accepted. Lines drawn at right angles to the cracks on the floor are probably at right angles to the direction of propagation of longitudinal waves, for these cracks are practically formed in the ground, like those described above; but cracks in walls can not be looked upon as at right angles to the direction of the movement, even when no windows are present to cause special weakness in some directions. We shall form a better conception of the mechanical conditions if we look upon the wave as divided into two components, one producing a horizontal vibration of the house and the other a vertical vibration. If, as is usually the case, the house is longer than it is high, the inertia opposing the motion will produce a horizontal shear and it may be shown, by the method used on page 34, that cracks have a tendency to form at an angle of  $45^\circ$  with the horizontal in walls running in the direction of the vibration; as the motion is first in one direction and then in the other, two sets of cracks would be formed at right angles to each other, and each  $45^\circ$  with the horizontal. The vertical component produces vertical compression and expansions which may slightly modify the direction of the cracks. This is exactly what was observed; many walls exhibited the double system of diagonal cracks. An excellent illustration of these cracks in the St. James Hotel at San Jose is given by Professor Omori.<sup>1</sup>

Chimneys, and walls running at right angles to the direction of the vibrations, were affected in a different way; they are high in comparison with their breadth and consequently were set into vibrations, like long rods. As they swayed back and forth they bent and were compressed on the concave and stretched on the convex sides. If this stretching exceeded the elastic limit of the material, a horizontal crack was made. It was in this way that chimneys were overthrown and the tops of walls and gables were thrown out. In practically all cases of brick walls and chimneys the break occurred at a joint and the bricks which were thrown down were usually unbroken, but entirely detached from each other, showing that the mortar was very weak. Chimneys of uniform thickness would naturally break at their lowest free point, which, in the case of the chimneys of houses, is where they pass thru the roof; and walls would break where they are not well braced, which was usually near their tops or in the gables or at the corners. The high chimneys of factories are thicker near the ground and gradually diminish in diameter and thickness from the ground up. They did not break at the ground, but at some point about a third of the way up where the bending moment was greatest in comparison with their strength. It by no means follows that a broken chimney will fall; in regions where the shock was not so very strong, many short chimneys were broken, and the detached part rocked on the lower part without overturning; the very small power of stretching possessed by brick and mortar caused chimneys to break before they were sufficiently inclined to lose their balance and fall.

## ROTATORY MOVEMENTS AND THE ROTATION OF OBJECTS ON THEIR SUPPORTS.

It has been a matter of frequent observation that during the shocks of large earthquakes a twisting motion is felt, and after the shock, chimneys which were not thrown down, monuments in cemeteries, ornaments, etc., are found to have been rotated on their

---

<sup>1</sup>Bull. Imperial Earthquake Investigation Commission, vol. i, No. 1, plate iv.

supports. This has given rise to the belief that there is a rotary motion of the various parts of the ground like that of wheels about their axes. It should be pointed out that this kind of motion can not exist, for it could not be propagated as an elastic disturbance, but would break up into waves of compression and distortion, which would be propagated at different speeds and would soon be separated from each other. Moreover such a motion would produce rents in the ground, which have not been found; nor has any such motion of the ground itself ever actually been observed. Waves of elastic distortion do, however, produce very small rotations, whose maximum amount, we shall see (page 146), is given by the expression  $\frac{2\pi A}{\lambda}$ , where  $A$  is the amplitude and  $\lambda$  the wave-length; with a wave as short as 10,000 feet (3 km.) and an amplitude as large as 0.2 of a foot (6 cm.), the maximum rotation would only be about 0.25 of a minute of arc, a quantity far too small to be noticeable; even if the rotation were 100 times as great as this, it would probably not be noticed.

But there is another kind of rotation, which undoubtedly does occur, and which would, if strong enough, give rise to the sensation of twisting and would cause objects to rotate on their supports. If a swinging pendulum, as it passes its lowest point, should receive a blow at right angles to the direction of its motion, it would simply change its direction and continue to swing back and forth in a different plane; but if the blow should be received at any other part of its motion, it would swing in an ellipse; if the blow were of the right intensity and were received at the end of the swing, the pendulum would swing in a circle.

Two vibrations making an angle with each other would produce just such an elliptical or circular motion, unless they were so adjusted that they would combine to make a simple linear vibration in a direction between the two; but this would rarely occur. If the two groups of combining vibrations had different periods, the resulting movement would be very complex; and we might have rotations first in one direction and then in the other. The kind of rotatory motion thus set up is not like that of a wheel about its axis, but is like that of a book which is carried around in a circle keeping the edge always parallel to its original position. We must look upon the rotatory motion of the earth reported during earthquakes as such that every point describes an ellipse, each point with a different center, but all with parallel axes; and the lines connecting near-by points remain parallel to their original directions, and do not, as in the case of a wheel, also rotate. For the sake of clearness let us speak of this kind of motion as *parallel rotation*, to distinguish it from rotations where the various points rotate around the same center.

We have conclusive evidence that the motion of the earth during the Californian earthquake was not merely a to-and-fro motion in one direction, but that the direction of the motion changed markedly. This is shown by the sensations of observers and by the fact that objects in the same place were thrown in various directions; statements that the earthquake was a "twister" were not uncommon, and some observers reported that the motion was first in one direction and then at right angles to it; and lastly the seismographs themselves indicate a combination of simple vibratory motions; this is well shown in the seismogram made by the simple pendulum at Yountville, and in all made by Ewing duplex pendulums. (See Seismograms, sheet No. 3.)

We can picture to ourselves many ways in which movements in different directions could be produced at the same time. Suppose, for instance, that there were two shocks originating at the same place with some seconds interval between them; each in general would give rise to compressional and distortional waves; the first kind travels faster and hence outraces the second. The compressional waves of the second shock would overtake the distortional waves of the first shock in a circular zone surrounding the origin, and as their motions are at right angles to each other, we should find parallel rotations in this

zone. Again, suppose two shocks originated at different centers, their waves, in general, would cross each other at an angle, and we might have circular or elliptical motion as a result of the combination of the two sets of compressional waves, of the two sets of distortional waves, or of each set of compressional with the other set of distortional waves. Modifications of the waves on passing from one kind of rock to another would occur and give rise to still other combinations which would cause parallel rotations.

With the hope of throwing light on the progress of the rupture along the fault-plane by determining the distribution of rotatory effects in the surrounding regions a special list of questions was sent out and many answers were received. They may be summarized as follows: at a distance, where the shock was but slightly felt, rotations were rarely noticed; but where the shock was strong, even tho many miles from the fault, they were almost universal; a number of observers stated that the disturbance was first a simple vibration, and that the rotatory motion only appeared later; no one put the rotatory motion in the early part of the shock. Some, who did not notice rotations, stated that the direction of the motion changed during the disturbance. At a distance from the fault, where the movement was slow and gentle, the rotatory effect would not be very noticeable, but that it still existed is shown by the seismogram made at Carson City, where the intensity of the shock was greatly reduced. This general distribution of parallel rotations does not show how the rupture took place on the fault, but merely confirms the idea that the disturbance at any point was due to vibrations originating in many parts of the fault-plane; and the combinations of these vibrations would cause the variations in intensity and the rotations observed. The writhing motion of the steel smokestack at Mare Island (vol. i, p. 212) must have been the result of a double vibratory motion of the ground combined into a parallel rotation; the elastic bending of the stack would cause a much greater vibration of the top than of the bottom; this explains the whole motion without the assumption of a tilting of the ground.

In the first volume numerous examples are given of statues, monuments in cemeteries, chimneys, etc., which were rotated on their supports by the earthquake; many were turned thru an angle of  $90^\circ$  and some as much as  $180^\circ$  (vol. i, p. 359), tho in the majority of cases the rotation was less than  $20^\circ$ . In the cemetery near San Rafael all except one of the rotated monuments were turned with the hands of a watch thru angles of  $16^\circ$  or less. Similarly, at Lakeport all the rotated chimneys were turned in the same direction (vol. I, p. 188). This phenomenon has long been observed and occurs at the times of all violent earthquakes; it naturally suggests a rotation of the support; but, as has been seen, a more careful examination of this idea shows that it is entirely untenable; indeed, Charles Darwin long ago pointed out that if objects were turned on their supports by true rotations, the axis of each rotated object must be an axis of the rotation, which is a practical impossibility. The effort, therefore, was made to explain the rotation merely as the result of a to-and-fro vibration. What is necessary is to produce a moment around the vertical axis thru the center of gravity.

Three suggestions have been made. First: Mallet<sup>1</sup> suggested that the object may not bear uniformly on its support, but may only press on it in a few points, and as the pressure will in general be different at these points a moment around the center of gravity due to the frictional forces would be produced during a vibratory movement, resulting in a rotation. Altho it may be possible for small rotations to be brought about in this way, they are probably very small and unimportant; for it can easily be shown that if the frictional forces at the points of contact follow the ordinary laws of solid friction, namely, that the tangential forces are proportional to the normal pressures, then no moment around a vertical axis thru the center of gravity will be set up by the vibrations, and it is only in so far as the ordinary laws of friction are departed from that moments can be

---

<sup>1</sup> Dynamics of Earthquakes. Trans. Roy. Irish Acad. 1846, vol. xxx, pp. 51-105.

produced. For the normal pressures must be such as to produce no moment around any straight line in the plane of the points of contact and immediately under the center of gravity; otherwise, the object, when undisturbed, could not remain stationary.

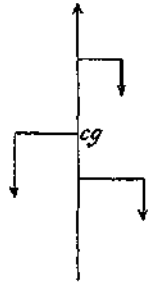

FIG. 23.

If now we take the straight line parallel with the direction of vibration, the moments of each frictional force about the vertical, thru the center of gravity, will be proportional to the moment of the corresponding normal force about the straight line, and therefore their sum will be zero. Houses, however, are not rigid bodies resting on rigid foundations, like a statue on its base; and the ground itself, on account of slight variations in texture or firmness, would not behave like a rigid body during the earthquake, but would have somewhat different movements at different places under the house; in this way it is quite possible for a house to be slightly rotated by the frictional forces between it and its foundation. Examples of such rotations are given in vol. I, pp. 170, 176.

Second: Professor Thomas Gray \* has shown that if the vibrations are at right angles to the edge of the rectangular base of a column, or along the line joining opposite corners, no rotating moment is developed; but if the shock lies between these directions, as, for example, in the direction, *of*, in fig. 24, then the column tends to rock on the corner, and to rotate around it; for the force is applied at the corner and acts in a direction parallel with the vibration and does not pass through the center of gravity. This is in entire accord with the laws of mechanics, and undoubtedly some small rotations are caused in this way; but it is to be noticed that the tendency is only to rotate until the edge is at right angles to the direction of vibration; if this direction is nearly at right angles to the edge, the rotation will be small; if the direction is nearly along the diagonal, the moment produced will be small; if the direction of vibration gradually changes, keeping pace with the turning of the column, a larger rotation might accumulate. In the case of columns with circular bases, the method would not apply at all; and it may be well doubted if any large rotations are produced in this way.

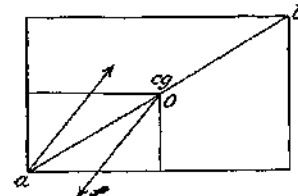

FIG. 24.

Third: The combination of vibrations at right angles offers a simpler explanation for any amount of rotation and for any form of base. If an object, as a result of the vibration, is rocking on its edge and is then subjected to a second vibration at right angles to the first, a strong moment will be set up and the object will rotate; if these vibrations are so timed as to produce parallel rotation of the support, the body will continue to rotate as long as the vibrations are sufficiently strong. One can easily realize this experimentally by means of a chair. Raise the front legs slightly from the floor by pressing against the back; then press against the side of the chair, and it will swing around about  $90^\circ$  on one leg; or, place a box or bottle on a book, and then rotate the book, keeping it parallel with itself; if the movement be strong enough and the friction sufficient to prevent slipping, the object will rock and rotate. The principle of cross vibrations seems to be the true explanation of the rotation in most cases and in all cases where the rotation is large. Cross vibrations will not be produced by a single shock from a single center; but a protracted shock, or successive shocks from the same center, or shocks from different centers, will produce them; that is, they will practically occur at the time of all large and important earthquakes, for then the vibrations usually originate at many points and at slightly different times.

<sup>1</sup> Milne, The Earthquake in Japan of Feb. 22, 1880. Trans. Seism. Soc. Japan, vol. i, part II, pp. 33-35; and *Seismology*, p. 170.

The explanation of rotations by means of cross vibrations seems first to have been given by F. Hoffmann\* and later repeated independently by Mallet<sup>2</sup> and others, but it does not seem to have received the consideration it deserves. I think it is clear from this chapter that cross vibrations are not only capable of explaining rotations wherever the disturbance is sufficiently strong, but that no other theory, so far proposed, can explain satisfactorily the very large rotations which statues and monuments experience.

SURFACE WAVES IN THE MEGASEISMIC DISTRICT.

In addition to the ordinary vibrations which we have been studying, many persons reported waves in the ground which had the appearance of ordinary waves on the surface of water (vol. I, pp. 380, 381). They were not a peculiarity of the California earthquake, for similar phenomena have been recorded in connection with almost all great earthquakes and have given rise to much discussion as to their cause. It is probable that they result from the modifications of condensational vibrations by the surface, as appears from the following considerations. The resistance of a substance to compression and distortion depends upon the values of two coefficients:  $k$ , the coefficient of compression under equal pressure in all directions, and  $n$ , the coefficient of rigidity or shear. If we compress a small cube of any substance between two plates, the modulus of compression, that is, the ratio of the applied forces per unit area to the linear contraction, is called Young's

modulus, and its value in terms of the coefficients mentioned above is  $\frac{9nk}{3k-2n}$ . This

represents the resistance which the substance offers to compression. When the pressure is exerted, the cube is not only compressed in the direction of the pressure, but it expands at right angles to this direction, and the ratio of this expansion to the normal compression <sup>\*s</sup> *ore T*,  $\frac{2n}{3k-2n}$  of this ratio varies with different substances, but in general it is not far from 1:4. When the vibrations pass thru the interior of the earth, the rocks are subjected to compressions and expansions, but the surrounding rock allows only longitudinal contraction or expansion and the modulus of elasticity is then given by  $\frac{3k+4n}{8k+4n}$ , which is greater than Young's modulus. At the surface expansion can take

place upwards but not laterally, and it can be shown that here the modulus of elasticity is given by the expression  $\frac{3k+4n}{8k+4n}$ , and the ratio of the vertical expansion to the longitudinal contraction is  $\frac{3k-2n}{8k+4n}$ .

The values of  $k$  and  $n$  have been determined for a number of specimens of rock by Messrs. H. Nagaoka,<sup>3</sup> S. Kusakabe,<sup>4</sup> and Adams and Coker.<sup>5</sup> The average values which the last investigators found for granites are  $k = 4.3 \times 10^6$  pounds per square inch, and  $n = 3 \times 10^6$  pounds per square inch; and the vertical expansion would be nearly 0.3 of the longitudinal compression. As we pass down from the surface the increasing weight of overlying rock would greatly diminish the vertical expansion, and at a depth comparatively small would prevent it altogether. The actual vertical movement at the surface would be the addition of all the vertical expansions from the surface down. A longitudinal contraction of 1: 8,350, as found in the example already used, would cause a vertical

<sup>1</sup> Nachgeschene Werke, 1838, vol. n, p. 310.  
<sup>2</sup> The great Neapolitan earthquake, vol. 1, pp. 375-381.  
<sup>3</sup> Elastic Constants of Rocks and the Velocity of the Seismic Waves. Publications of the Earthquake Investigation Commission in Foreign Languages, No. 4, 1900; and Phil. Mag. July, 1900, vol. t.  
<sup>4</sup> On the Modulus of Rigidity of Rocks. Publications of the Earthquake Investigation Commission in Foreign Languages, No. 14, 1903; No. 17, 1904; and No. 22B, 1906.  
<sup>5</sup> An investigation into the Elastic Constants of Rocks, etc. Carnegie Institution of Washington, Publication No. 46, 1906.

expansion of about 1:30,000; if we assume that the weight of the overlying rock would make the vertical expansion practically disappear at the depth of a mile; and if we assume further that the average expansion above this point is one-third of its value at the surface, we should find a vertical amplitude at the surface of 0.66 inch, or a range from crest of trough of the waves of 1.33 inches.

Referring again to the expression for the ratio of the vertical expansion to the horizontal compression we see that its value will become greater as  $n$  becomes smaller, with unity for its greatest possible value. When the waves pass from rock into alluvium or distinct-grained rock, the amplitude may become distinctly larger, and since the value of  $n$  would be much less than for granite, we should expect far larger surface waves. The movement at the surface will be upwards, forwards, downwards, and backwards in the vertical plane, just like the movement in ordinary water waves. Waves of this kind must necessarily occur wherever we have longitudinal vibrations, at a great distance from the focus as well as near it, but it is only where the amplitude of the vibration is very large that the surface waves are visible to the eye; and it is, therefore, only near the focus, and generally only on alluvium that they are observed, and only in the case of very violent earthquakes. These waves must not be confused with the Rayleigh waves, in which the horizontal component of the vibration dies out at a depth of about one-eighth wavelength, and the vertical component continues to indefinite depths; whereas the waves we have just described have exactly the opposite characteristic; they are simply the surface modification of the ordinary longitudinal waves, which exist below the surface.

It is also possible that surface waves could be formed by transverse vibrations, in which the direction of motion is vertical.

Major Dutton<sup>x</sup> thinks that the surface waves have no relation to the elasticity of the rock. He says: "Their lengths are too small, their amplitudes too great, and their speeds of propagation too slow to be dependent upon elasticity"; but if we refer to the modulus of elasticity which holds near the surface, and upon the square root of which the velocity of transmission depends, we see that its value becomes very small as the value of  $n$  diminishes and therefore in some alluvium it is quite possible to have slow speeds and short wavelengths, and, as we have seen, large amplitudes. It is not necessary to believe that the amplitudes of surface waves are nearly as large as they appear, for it must be remembered that an observer being shaken by the strong vibrations of a violent earthquake is in a difficult position to make good observations on the phenomena about him, and particularly to distinguish between the movements which are actually taking place and those which he apparently sees, but which are really due to his own oscillations. We have many descriptions of trees and telegraph poles being swayed so violently as nearly to strike the ground, which of course is impossible, as the distortion of the earth necessary to produce this result would have caused disruptions which were not observed; and moreover, a small vibratory movement is sufficient to cause very great commotion among trees, which would naturally be referred by an observer to tiltings due to surface waves.

---

<sup>1</sup> Earthquakes, p. 144.

## THE INFLUENCE OF THE FOUNDATION ON THE APPARENT INTENSITY.

---

### THE GREATER DAMAGE ON ALLUVIUM.

Experience shows that the damage done by destructive earthquakes is much greater on alluvial soil than on solid rock. A glance at the isoseismal map No. 23 will show how well this was exemplified by the California earthquake. Probably the best example we have is the city of San Francisco itself, which is built variously on solid rock, on sand, on natural alluvium, and on "made ground." The description of the destruction done in the city (vol. i, pp. 220-245.; maps, Nos. 18 and 19) shows that within its limits the character of the foundation was a far more potent factor in determining the damage done than nearness to the fault-line. This is not a question of the transmission of vibrations, for, on account of the higher elasticity of solid rock, it would transmit vibrations far better than alluvium, and indeed, as the alluvium occupies limited and comparatively shallow basins in the rock, the vibrations are always transmitted from a distance thru rock; and the question really to be answered is: How are the vibrations modified in a basin of alluvium so as to make them more destructive than without this modification? By analogy the well-known experiment of the ivory balls has been invoked to explain the fact. If the first of a row of ivory balls in contact receives a sharp blow, it transmits the shock to the next ball, but remains almost stationary itself; the shock is thus transmitted from ball to ball, and the last one, having nothing before it, flies off. It is said that the surface of alluvium having nothing above it, and having little cohesion, experiences a much stronger vibration than a rock-surface under similar circumstances. But the analogy does not seem to me a good one, for the lack of constraint of objects above the surface is the same whether we are dealing with rock or with alluvium; and it is only in so far as a lack of cohesion in the alluvium would permit its surface to be thrown into the air that a difference in the two substances might be supposed to make itself evident; but in the cases we are considering, the shock is not nearly strong enough to produce such an effect; and besides, structures built on rock are not usually firmly attached to it; they would be thrown upwards just as easily as tho they rested on alluvium; if subjected, in the two cases, to the same vibratory acceleration.

NOTE. — When a transverse wave, in which the vibrations are parallel with a free surface, is reflected from the surface, the amplitude at the surface is twice as great as that of the incident wave; the amplitude varies periodically with the distance from the surface in such a way that it equals the large surface amplitude at distances of any even number of times  $X/4 \cos i$ ; where  $X$  is the wave-length, and  $i$  is the angle of incidence; and it is zero at distances of any odd number of times the same expression. With transverse waves not parallel with the surface or with longitudinal waves the problem is much more complicated; it would still resemble the simpler case, but the variations of intensity would be less marked. The strong surface motion would extend some distance into the medium; this is probably why observations in mines have shown practically the same intensity of movement as at the surface; the depth of the mines is only a fraction of  $X/4 \cos i$ .

### THE THEORY OF MR. ROGERS'S EXPERIMENT.

With the object of throwing light on this subject, Mr. J. F. Rogers made some very interesting experiments (vol. i, pp. 320-335), in which sand containing various amounts of water and held in a wooden box was caused to vibrate to and fro and the movement of the top of the sand compared with the movement of the box. The outside forces are

applied to the sand either at the base or at the sides of the box and must be transmitted thru the sand. What is the character of this transmission? Evidently it must depend upon the amount of water contained in the sand and also upon the frequency of the vibrations. If the sand is fairly dry and the frequency slow, the sand will act very much as an elastic solid body and we may assume that the successive horizontal layers shear slightly over each other as a solid would do, and that the forces brought into play are proportional to the shear. The movement under these conditions, when we neglect the influence of the sides of the box, would be somewhat like the movement of a flexible rod fastened to the bottom of the box. The rod, however, would be bent with compressions and expansions on opposite sides, whereas the sand is distorted simply by the elastic shear of successive horizontal layers over each other; but the character of the motion in the two cases is very similar. To understand the movements of the sand we must consider the forces acting between the successive layers. The equation of motion of such a system (provided the motion is not too large) is

$$d^2y - n c P''y$$

where  $x$  is measured vertically upwards, and  $y$  in the direction of motion;  $t$  is the time,  $p$  the density of the material, and  $n$  its coefficient of rigidity or shear. The solution of the equation if the column of sand were slightly distorted, and then allowed to vibrate without further disturbance, is

$$y = A \sin \frac{x}{\lambda} \sin \frac{2\pi}{T_0} t \tag{2}$$

where

$$\frac{\lambda^2}{4\rho l} = \frac{n}{\rho}$$

This represents a standing wave, of wave-length  $\lambda$  and period  $T_0$ . The period may have a great number of values, namely:

$$T_0 = \frac{4H}{2m+1} \sqrt{\frac{\rho}{n}} \tag{3}$$

and the corresponding wave-lengths are

$$\lambda = \frac{4H}{2m+1} \tag{4}$$

where  $H$  is the thickness of the sand; and  $2m+1$  is any positive, odd, whole number. Introducing these values in (2) we get

$$y = A \sin \frac{2\pi(2m+1)}{4H} z \cdot \sin \frac{2\pi}{4H} \sqrt{\frac{n}{\rho}} t \tag{5}$$

The longest period with which the system can vibrate is

$$T_0 = 4H \sqrt{\frac{\rho}{n}} \tag{6}$$

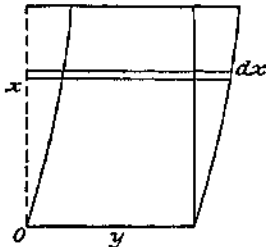

FIG. 25.

but in addition there may be superposed the odd harmonics. For the simplest vibration an originally vertical straight line would be changed into a quarter of a sine curve, as shown in fig. 25. Equation (6) is the expression used on page 39 to determine the free period of vibration of the strained rocks near the fault-plane at the time of the earthquake.

Suppose, instead of vibrating freely, the base of the sand is made to vibrate according to the expression  $B \sin \left( \frac{2\pi}{P} jt \right)$  i.e., with an amplitude  $B$  and a period  $P$ .



The solution of equation (1) under these conditions is

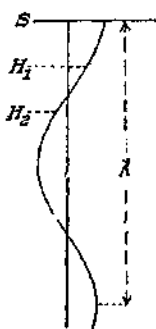

FIG. 26.

$$y = \frac{B}{\cos \frac{2\pi}{X} (H - x)}$$

where  $X$ , the length of a distortion wave of period  $P$  in the sand, supposed of indefinite extent, equals  $P \sqrt{\frac{P}{\rho}}$ . Equation (7) shows that a vertical straight line in the sand is distorted into a cosine curve with its maximum amplitude at the surface. Fig. 26 shows the form of this curve;  $S$  is the surface and only that part of the curve is followed which lies between  $S$  and the bottom at the distance  $H$  below it. At the surface  $x = H$ , since  $x$  is measured from the bottom, and the amplitude becomes

$$\frac{B}{\cos \frac{2\pi H}{X}} \tag{8}$$

and this varies between  $B$  and infinity, according to the value of the ratio of  $\frac{H}{X}$ . If  $H$  is any even number of times  $\frac{X}{4}$  the denominator becomes 1 and the amplitude becomes  $B$ . If  $H$  is any odd number of times  $\frac{X}{4}$  the denominator becomes 0 and the amplitude infinite. If, instead of varying the depth, we suppose it constant and vary the period of the disturbance, we get similar results. Replace  $X$  in (8) by its value and the surface amplitude becomes

$$\frac{B}{\cos \frac{2\pi \lambda L}{P \sqrt{\frac{n}{\rho}}}} \tag{9}$$

The free periods of the system are given by equation (3), and if  $P$  has one of the values there given, the denominator of (9) becomes the cosine of an odd number of times  $\frac{\pi}{2}$ , which is 0, and the amplitude becomes infinite. Practically, of course, friction or a slipping of the sand particles would prevent the amplitude from becoming extraordinarily large.

We see, therefore, from (7), (8), and (9) that the surface would vibrate with the same period as the base and that it would always be in the same or in the opposite phase; that its amplitude would never be less than that of the base and that it would in general be larger and might become indefinitely large when the depth of the sand is an odd number of times a quarter wave-length, a wave-length being determined by the density and rigidity of the mass and the period of vibration; or what amounts to the same thing, when the period of vibration becomes equal to one of the free periods of the system. If, however, the frequency of the vibration should be too great, the bond between the different grains of sand would be broken, and the conditions upon which the above conclusions are based would no longer hold; the sand grains would slip over each other, and the amplitude of the upper surface would be diminished. If we apply the above theory to Mr. Rogers's experiments with dry sand, we find it in close agreement with his results. When the frequency is very low, the sand moves with the box; in terms of the theory, we are dealing with only the upper part of the curve in fig. 26, and since  $H$  is very small in comparison with  $X$  the surface amplitude as given by (8) becomes  $B$ , the amplitude of

the base. As the frequency increases the wave-length,  $X$ , decreases, and the surface amplitude increases; we have to do with a longer part of the curve in fig. 26. When the frequency becomes too large, the surface amplitude begins to decrease, suggesting that the sand no longer acts as a solid, but that slipping takes place. The addition of a small amount of water to the sand diminishes the cohesion between the grains, which reduces the value of the coefficient of rigidity,  $n$ , and shortens the wave-length, for a given frequency; we therefore get larger surface amplitudes, but slipping occurs at lower frequencies than with drier sand. As the sand is probably only able to bear a definite shearing force without slipping, an increase in the amplitude of vibration would cause the slipping to begin at a lower frequency than with smaller amplitudes. The conclusions are in good accord with Mr. Rogers's results as shown graphically in his figs. 62 and 63.

When, with increasing frequency, the slipping first begins, it must take place only at the ends of the strokes where the acceleration, and therefore the force, is greatest; but as the frequency gets still higher, the slipping is spread over a greater and greater part of the stroke and the surface amplitude becomes less and less; the mathematical theory we have sketcht out does not apply after slipping begins.

So far we have considered the motion as communicated to the sand from the bottom of the box and not by the pressure of the sides, which would undoubtedly modify it, but the results given by Mr. Rogers are for the sand near the middle of the box where the sides have the least influence; and in one experiment where the sand was piled up on the bottom of the car without touching the sides, the results were not altered; it appears therefore that in the case of sand which is not too wet, and for frequencies not high enough to cause slipping, the influence of the sides has not been great enough to alter the general character of the motion of the sand in the middle of the box; but near the sides their influence causes much confusion in the motion of the sand.

When the sand is thoroly soaked with water, it becomes very plastic, the elastic forces become very small and viscous forces become the predominating forces between the successive layers. We therefore determine what is the character of the motion transmitted from the bottom by means of viscous forces. We find that transverse waves are set up which advance to the surface and are there reflected back again. These waves have a wave-length dependent upon the density of the material and the viscosity, and are very quickly damped out. Indeed, the amplitude of the advancing wave is reduced to less than  $1/500$  of its original value at a distance of one wave-length from the base, and the reflected wave starts with a small amplitude and dies out very rapidly. We find that the amplitude at the surface is always less than that at the base and that its value is twice as great as that of the direct wave at the surface if it were not reflected; that is, if the depth of the sand were one wave-length the amplitude at the surface would be about  $1/250$  of the amplitude at the base, instead of about  $1/500$ , as in the case of no reflected wave. It is quite evident that waves of this character could not explain the movement of the wet sand in the experiment; and we therefore turn our attention to the influence the sides of the box would have on the motion of a fluid as viscous as the mixture must be. As Mr. Rogers says, the damping is so great that the mixture could not have a free period of its own. The experiment described in vol. i, pp. 328 and 329, and illustrated by fig. 61, shows very well the character of the motion, namely, that the surface material moves very steadily during the greater part of its excursion with a fairly uniform velocity, somewhat greater than that of the base, and that its velocity is rapidly reversed at the end of the stroke. This being the case we conclude that there is little force acting upon the sand except near the ends of its excursion and that there a strong force acts for a short time. It seems probable, therefore, that as the box diminishes in velocity towards the end of the stroke the sand, by its inertia, is carried forward and raises the mixture in

front of it against the side of the box; this together with the return movement of the box produces a strong force which quickly reverses the movement of the sand, giving it a velocity slightly greater than the maximum velocity of the box; but the force is not active again until the box approaches its maximum displacement on the other side. The movement therefore depends upon the action of the sides of the box and is not transmitted from the bottom. It is clear from Mr. Rogers's experiments that the forces when the sand is dry are very different from those when the sand is very wet; and when different parts of the sand contain different amounts of water, that the movements would be so different as to produce much confusion.

#### APPLICATION OF THE THEORY TO SMALL BASINS.

When we attempt to apply the results of the experiments to explain the case of the greater disturbance in alluvial soil than in rock, we recognize with Mr. Rogers that it is dangerous to carry analogy from such small quantities to such large masses, and we must be very carefully guided by theory if we wish to avoid great error.

As already noted, alluvium occupies basins in the rock of more or less extent, and in considering its motions we must divide the basins into two classes; the first comprises those basins which are small enough, in the direction of propagation, for all parts to move practically in the same phase, like the box in Mr. Rogers's experiments; that is, they must be not much larger than an eighth of the wave-length of the waves in the surrounding rock. With waves whose period is as short as a half second, the basins may be somewhat more than a quarter mile across; but with periods as long as 10 seconds, they may be over 5 miles across, and still be in this class. The second class comprises all large basins, where the progressive character of the wave-motion must be considered.

Where alluvial basins are not extremely small, they are always much broader than they are deep, usually many times as much; and they are also saturated with water. When the material is largely sand or gravel, the grains are held so closely together by the weight of the material lying above them that the vibrations can be transmitted from the bottom in the same way as with dry sand; but when the material is soft mud, transverse vibrations can not be so transmitted and the influence on the sides becomes predominant. The limiting case of fluidity is exemplified by streams, ponds, and even vessels containing water or milk, where the liquid may be so greatly agitated as to be splashed out on the sides. Mr. Rogers's experiments seem to explain pretty satisfactorily the larger surface amplitude and the greater damage done in the class of small basins of alluvium; but it must be noted that the basins have not a flat bottom like a box, but have rather an open V shape, like stream valleys; and there is no abrupt distinction between the bottom and the sides. Where the material is sufficiently solid, the vibrations are transmitted both as transverse and longitudinal vibrations from the bottom, the surface amplitude being in general greater than at the base and varying with the depth, the coefficient of rigidity, and the period of the vibration; the depth of a basin is more or less irregular, the character of the material, and therefore the coefficient of rigidity, varies from point to point; therefore the amplitude will vary from point to point on the surface, and points not far apart may be even in opposite phases, so that more or less discordant movements take place. The commotion may be sufficiently great to produce cracks in the ground, especially at the boundaries of softer and firmer material. The damage to buildings is due more to the discordant character of the disturbance than to the mere increase in amplitude at the surface of the alluvium, for deep pilings with a strong concrete capping diminish the damage to a remarkable degree; the capping must move nearly as a rigid body and relieve the building above it from different movements in different parts of its foundation. The capping must also diminish the amplitude, for movements in opposite direc-

tions of neighboring parts of the alluvium would be nullified by it. When the alluvium is so soft and plastic that shearing forces are insignificant, the alluvium is flung back and forth by the reaction of the sides of the basin with effects apparently still worse than in the former case; and with the formation, near the sides, of elevations and depressions resembling wave-surfaces; but they are not true progressive waves, for the rigidity is too small for the surface waves described on page 47 to be formed; and the viscosity is too great to permit of gravitational waves, but the violent to-and-fro motion of the basin and the low rigidity produce, near the sides, elevations resembling a wave surface, and the motion of the soft alluvium is so quickly damped out by its viscosity that the form is fixt and remains after the disturbance is over. This condition was characteristic of the small filled-in swamps of San Francisco, usually accompanied by a general lowering of the surface, due to the character of the refuse used for filling them; this material was so little consolidated that the surface has been steadily sinking for years (vol. i, pp. 241-242), and its volume was materially reduced by the shaking of the earthquake.

#### LARGE BASINS.

The second class of alluvial basins are those which are too large to be lookt upon as moving as a whole; that is, they are larger than an eighth wave-length; in some cases they are many wave-lengths in breadth. They are represented in California by the large valleys, the Santa Clara, the San Joaquin, etc. We must picture them to ourselves as broad, shallow basins with irregular floors and containing material whose coefficient of rigidity varies considerably even in neighboring parts; this material is principally water-soaked sands and gravels, given a certain amount of rigidity by the weight of the material above it. As the elastic waves pass thru the underlying rock they enter the alluvium and are refracted upwards on account of the smaller velocity in the alluvium than in the rock. If the angle of incidence is sufficiently small, the amplitude of vibration in the alluvium will be larger than in the rock; for instance, if we assume the density of the alluvium to be 0.8 that of the rock, and the velocity of propagation one-fifth as great, then for normal incidence the amplitude of the refracted wave in the alluvium would be nearly double that of the incident wave in the rock, both for compressional and for distortional waves. After entering the alluvium the waves would be reflected back and forth from the surface and bottom until they were damped out by the viscosity of the alluvium; for normal incidence the amplitude of the wave reflected from the bottom would be fifteen-sixteenths that of the incident wave, and then a large part of the motion would be kept in the alluvium. When the angle of incidence from the rock to the alluvium is greater than zero, two reflected and two refracted waves are produced; and when this angle is not large the refracted wave in the alluvium would still have a larger amplitude than the incident wave in the rock. When reflected at the surface, the wave would have its phase changed by half a period, and if the length of its path to the floor and back again were a half wave-length, it would find itself in the same phase as the direct wave when it again reached the surface, and the resulting amplitude would be the sum of the amplitudes of the two waves. In many parts of the basins this relation of depth to wave-length must approximately have existed for some of the waves present in the earthquake disturbance. Repeated reflections would probably result in a surface amplitude considerably greater than would occur at the surface of continuous rock; and the irregularities mentioned above would cause discordance of motion hi points near together, and thus greatly increase the damage.

A thin coating of alluvium over the rock would evidently move with the rock and would not have an especially large amplitude; it would be necessary for its depth to be something like an eighth of a wave-length to obtain the full effect; the small velocities

of transmission in alluvium would allow this condition to be satisfied even with a much smaller depth than was found in many parts of the large Californian valleys.

Surface waves would also be a strong factor in causing damage on alluvium; these waves and the irregularities due to varying coefficients of elasticity are probably the principal causes of the increased damage on alluvial soils, even when of sufficient thickness to experience the accumulated amplitudes described above.

The sides of the basins would exert no special influence except in their immediate neighborhood; but a certain amount of irregular reflection and refraction there would probably cause unusual intensity at some points.

THE FOUNDATION COEFFICIENT.

At Professor Lawson's suggestion I have attempted to find some quantitative relation between the intensity of the shock on sands, marshy land, and solid rock.

We shall first consider small basins within the limits of San Francisco. If we look at the profiles drawn by Mr. Wood and reproduced in map 18, we find the following estimates of the accelerations (a column has been added to the table giving the ratios of the accelerations on the various materials to that on the most solid rock. I have called this ratio the *foundation coefficient*):

TABLE 4. — *The Foundation Coefficient (San Francisco).*

SECTION.	FOUNDATION.	ACCELERATION mm./sec. <sup>2</sup>	FOUNDATION COEFFICIENT.
EF	Serpentine . . . . .	250	1.0
EF	Made land . . . . .	1,100	4.4
EF	Marsh . . . . .	3,000	12.0
CD	Sandstone . . . . .	250 to 600	1 to 2.4
CD	Made land . . . . .	2,900	11.6
CD	Sand . . . . .	600	2.4
CD	Sandstone . . . . .	400	1.6
AB	Sand (Mission Valley) . . . . .	1,100	4.4
AB	Marsh . . . . .	3,000	12.0
AB	Sundry solid rocks . . . . .	250	1.0

These observations are not all entirely independent; for instance, the marsh indicated in the first and last sections is the same marsh, as these two sections go thru it; and the first two sections cross on the sandstone of Telegraph Hill. The high intensity at the southwestern extremity of section *AB* has not been considered because it is too near the fault; nor has the local strengthening of the intensity near the middle of section *CD*, which apparently is not to be explained merely by the nature of the terrane at these points. The very low intensity of only 250 millimeters per second per second on solid rock indicates a smaller intensity in San Francisco than further north, where we should have to go at least three times as far from the fault-line to find the intensity so low. The table, which gives only a very rough approximation to the coefficients, shows that the damage on small marshes may represent an acceleration as much as 12 times as great as on solid rock; on made land, from 4.4 to 11.6 times as great; on loose sand, from 2.4 to 4.4; and on sandstone, from 1 to 2.4. Altho it has been well known that the apparent acceleration on soft land is much greater than on rock, the ratios obtained seem very much greater than had been suspected.

The following table gives a list of places on alluvial soil in basins of considerable size, too large to be considered *small* basins, in the sense we have used that word.

TABLE 5.—*The Foundation Coefficient (Distant Points).*

PLACE.	EOSSI-FOBBL SCALE.		ABSOLUTE SCALE.		FOUNDATION COEFFICIENT.
	Apparent Intensity.	General Intensity.	Apparent Intensity.	General Intensity.	
Salinas . . . . .	IX	IV+	2,000	125	16
San Jose . . . . .	IX	VII?	2,000	300	7
Santa Rosa . . . . .	X	VIII	2,500	1,200	2
Ukiah . . . . .	VIII	VII	1,200	250	5
Willits . . . . .	IX	VII	2,000	250	8
Clear Lake . . . . .	VIII	VI	1,200	200	6
Priest Valley . . . . .	VII	IV*	-300	100	3
Sacramento . . . . .	VI*	V*	200	125	2
Los Banos . . . . .	IX		200	125	16
West San Joaquin Valley	VIII +	<b>M</b>	1,600	125	12

The intensities are given both in the Rossi-Forel scale and in the absolute scale of accelerations; the first column under each scale gives the *apparent* or felt intensity, and the second gives the *general* intensity or what seemingly would have been felt on solid rock if it had existed there. To determine the general intensity requires the exercise of some judgment, guided of course by the intensity map, No. 23; this quantity therefore is subject to considerable error. The same is true of the values in the absolute scale; we have used Professor Omori's estimates of the absolute values of the Rossi-Forel scale for intensities of <sup>^</sup>VII or more \* and Professor Holden's estimates for the lower intensities.<sup>2</sup> The difficulties of obtaining the correct intensities, apparent and general, according to the Rossi-Forel scale, and the further difficulty of translating into the absolute scale, on account of the larger difference between the successive degrees of higher numbers of the former scale, make the values obtained only approximate; therefore it must be recognized that the foundation coefficients are far from accurate.

The regions about Sacramento, Santa Rosa, and Priest Valley seem to have had their intensities increased least of all the alluvial basins. The great destruction of Santa Rosa suggested a special disturbance in that region, but this seems entirely unnecessary in view of its low coefficient in the table. The Salinas and San Joaquin Valleys have exceptionally high coefficients. The value at Salinas is probably accounted for by the extremely loose character of the alluvium in the flood-plain of the river and its nearness to the fault; but the low value at Sacramento suggests that a similar explanation may not be satisfactory for Los Banos and the San Joaquin Valley; and the high intensity the whole length of this valley has suggested an auxiliary fault in the region. The fact that the greatest northeastern extension of the lower isoseismals is not opposite the center of the known fault, but almost opposite its southern end; and the extension of the same isoseismals to the southeast, where they are more nearly symmetrical with respect to the San Joaquin Valley than with respect to the known fault, support the view of an auxiliary fault in or near this valley. On the other hand, it is quite possible that the intensity in the valley has been overestimated, and that the alluvial character of the ground may account for the intensity that actually existed there. I am inclined to think an auxiliary crack the best explanation of the high intensity in the San Joaquin Valley; but the evidence for it is by no means satisfactory. (See further, vol. i, pp. 344, 345.)

The great differences in the coefficients found for the different alluvial basins are much too great to be accounted for by inaccuracies in their determinations; we must conclude that there are differences in the character and in the depth of the alluvium in different basins, and probably even in different parts of the same basin, which are important factors in the values of the coefficients.

<sup>1</sup> Publications of the Earthquake Investigation Commission in Foreign Languages, No. 4.  
<sup>2</sup> Dutton's Earthquakes, p. 128.

PART II

INSTRUMENTAL EFFECTS OF THE EARTHQUAKE

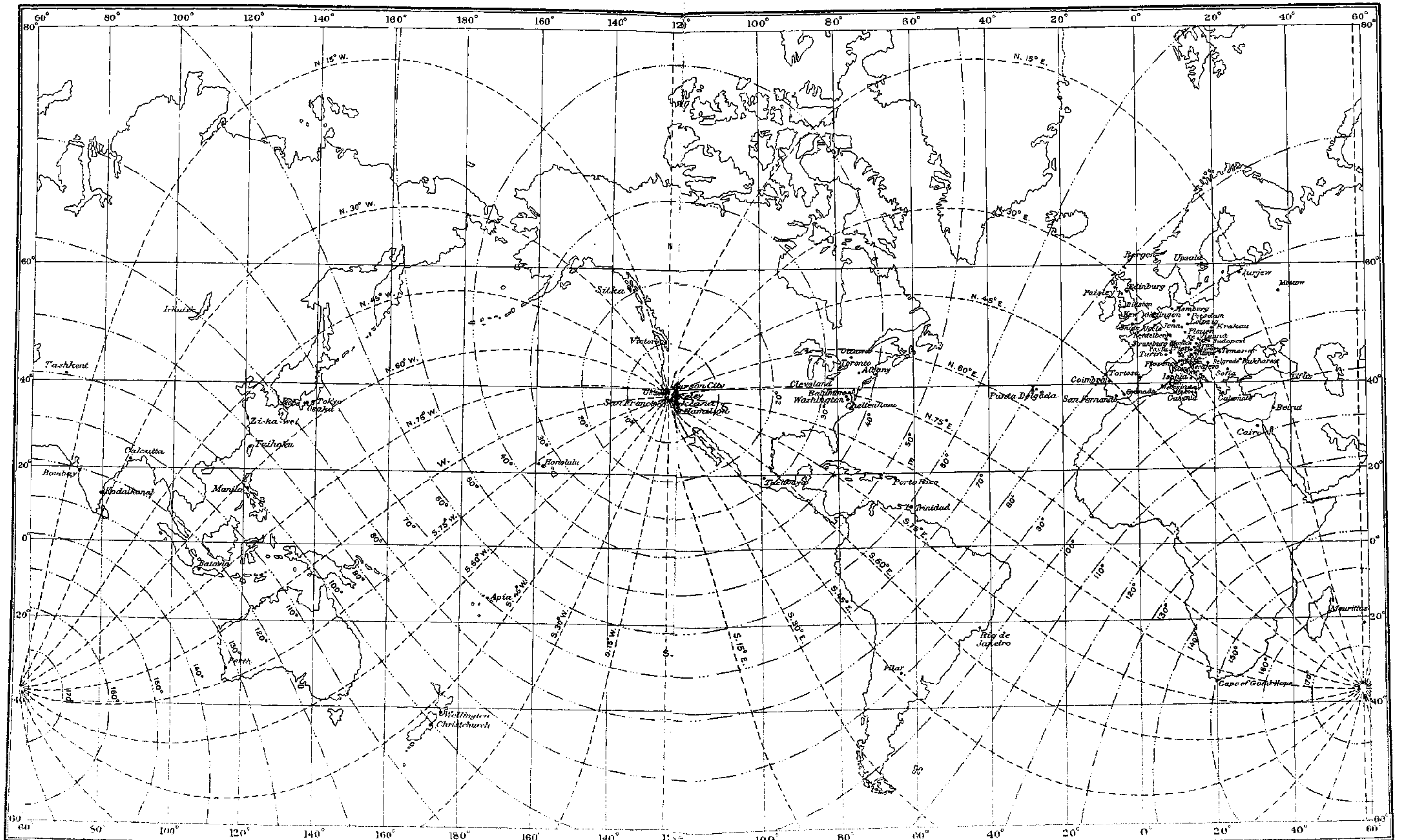

MAP SHOWING DISTANCES AND DIRECTIONS FROM THE ORIGIN OF THE SHOCK



## COLLECTION AND REPRODUCTION OF THE SEISMOGRAMS.

The intensity of the shock was so great that practically all seismographs, situated in any part of the world, recorded it. Shortly after the earthquake letters were addressed to all the seismological observatories in the world asking for copies of their seismograms and other necessary data, and the Commission takes pleasure in expressing its thanks to the directors of the various observatories, who were kind enough to send reports and either their original seismograms or copies, which have been reproduced in the Atlas. A few, however, were too faint for reproduction and have been omitted.

In the great majority of cases, copies of the seismograms, and not the originals, were sent; and it was not thought necessary to reproduce them in facsimile, especially as the International Seismological Association has recently reproduced in facsimile the seismograms of the Valparaiso and Aleutian earthquakes of August 16, 1906. A very careful tracing was therefore made of each seismogram and this was reproduced by photolithography. Some of the seismograms, especially those made by Milne instruments, do not lend themselves to this method, and they have been reproduced by a gelatin process. Some of these were too faint in places to yield good reproductions; they were accordingly slightly strengthened, the draftsman keeping well in view the character of the instrument and being guided by the marginal records, so that the true form of the central record has been preserved.

Great care has been given to all reproductions, and the characteristics of the various seismograms have been well brought out.

In printing the seismograms those recording times are so placed that the time increases from left to right; it has not always been possible also to make the time increase from top to bottom, but an arrow has been placed at the beginning of the record so that this part can readily be found. In most cases the times are given in Greenwich mean civil time (G. M. T.), 0 hours beginning at midnight. Where a correction is necessary or where local time is used, the correction to reduce to G. M. T. is given under the seismogram, the total correction is always given, including the error of the clock, the parallax of the recording stylus, and the correction for longitude where local time was used.

The seismograms are reproduced in their original size, except in a few instances, which are noted. These were cases in which they were extremely large and the copies supplied were from hand tracings, so that nothing was lost by the reduction; or cases in which the copies were already reduced. The seismograms on sheets 1 and 2 have been inadvertently reduced about 2 per cent; but this is unimportant. It was desired to arrange the seismograms in the order of their distances from the origin, but on account of the two different methods of reproduction, and the greater number of plates this plan would require, it was given up and the seismograms arranged so as to make the smallest possible number of plates. The seismograms from any station can readily be found from the list of observatories, from the contents, or from the table of contents of the Atlas.

## OBSERVATORIES AND THE DATA OBTAINED.

In the following list the observatories are arranged in the order of their distances from the origin of the disturbance, and the map, plate 1, shows their positions graphically; it also shows their distances from the origin and the courses followed by the earthquake waves.<sup>1</sup> The distances of the stations are calculated along the arc in degrees and in kilometers, and along the chord in kilometers. In calculating these quantities the ordinary trigonometrical formulæ are used. The earth is considered spherical with a radius of 6,370 km.; which gives 111.18 km. for the length of one degree of arc. (We can readily convert kilometers into miles by multiplying by 1.6L) In the collection of data all information available aiding in the interpretation of the seismograms is given. Although other instruments in the same observatory may have recorded the shock, only those whose records were obtained are mentioned; and all their constants, so far as possible, are given. The component indicated refers to the direction of the earth vibrations recorded; for instance, a horizontal pendulum in the meridian would record the east-west component. The abbreviations used have the following meanings:

*T*, the complete period of the pendulum without damping.

*V*, the magnifying power for very rapid vibration.

*J*, the indicator length, as used by Professor Wiechert. It is the product of the length of the simple mathematical pendulum, having the same period, multiplied by the magnifying power, *V*. Its value is therefore  $(T/2\pi)^2 g V$ . It is also given by  $a/a$ , where *a* is the displacement of the pointer due to a tilt, *o*, of the ground. On account of friction these two values do not always agree. The value obtained by the first method is given; and

*Angular displacement* gives the displacement of the pointer due to a tilt.

*L*, the distance of the center of oscillation from the axis of rotation; it equals the length of a mathematical pendulum of the *same type*, as defined on page 155.

*V*, the length of the simple mathematical pendulum having the same period. Its value in meters is practically the square of half the period in seconds.

*M*, the mass of the pendulum.

*e*, the damping ratio of the vibrations.

*r*, the frictional displacement of the medial line, as defined on page 163, and shown in fig. 43.

In the majority of cases the values of the constants, or data sufficient to calculate them, have been supplied by the director in charge of the instrument; in the case of the Milne or the 10-kilogram Bosch-Omori instrument, the values of some of the constants could be obtained from exactly similar instruments installed in Baltimore. The value of *L* for the Wiechert inverted pendulum is taken from Dr. Etzold's report on the Leipzig instrument. The times of the arrival of the different components at the station as recorded by the various instruments refer to the *first preliminary tremors*, the *second preliminary tremors*, the *regular waves*, the *principal part*, and the *maximum disturbance*. The hour is usually omitted as unnecessary; when the times are reported in minutes and seconds, they are indicated thus, 21<sup>m</sup> 43<sup>s</sup>; when they are reported in minutes and tenths of minutes they are indicated thus, 21.7<sup>m</sup>. The *interval* of time required for the waves to reach the station is given by subtracting the time of the shock, 12<sup>m</sup> 28<sup>s</sup> or 12.5<sup>m</sup>, from the time of arrival. The *amplitude* is the displacement of the pointer from its position of equilibrium measured on the seismogram in millimeters, and always refers to the maximum disturbance unless it stands opposite some other time. The *earth's amplitude* is the corre-

<sup>1</sup> ERRATA. — Two of the stations have been slightly misplaced. Kodaikanal, Madras, should be about 2.5 mm. north of the southern end of India and about equally distant from the sea to the east and west. Mauritius should lie in the southeastern angle between the line marking 20° S. latitude and the red north-south line thru the antipodes of the origin, and practically touching these lines.

sponding displacement of the earth. The *'period* relates to the period of the earth-waves as recorded on the seismogram, and not to the natural period of the pendulum. Some of the times and other quantities relating to the records were sent by the directors of the various observatories, some were extracted directly from the seismograms. A discussion of any special characteristics which a seismogram may have follows the records of each station.

Usually different instruments at the same station give somewhat different times for the arrival of the various phases. The cause of these differences is not known and the average has been taken as the record of the station. In a few cases some instruments have evidently been late in responding to the disturbance; their records have been disregarded.

The *direction* of a station is the angle at the origin between the meridian and the great circle passing thru the origin and the station.

In order more readily to find the data of any particular station the following alphabetical list refers to the records and the seismograms.

*List of Observatories.*

STATION.	PAGE.	SEISMOGRAM, SHEET No.	STATION.	PAGE.	SEISMOGRAM, SHEET No.
Agram (Zagreb), Hungary	93	...	Messina, Italy	100	12
AJameda, California	63	3	Mizusawa, Japan	73	...
Albany, New York	71	8	Moscow, Russia	84	...
Apia, Samoa	72	...	Mount Hamilton, California	64	"3
Baltimore, Maryland	71	1	Munich, Germany	85	5
Batavia, Java	106	15	Oakland, California	62	3
Belgrade, Servia	97	...	O'Gyalla, Hungary	91	...
Bergen, Norway	74	...	Osaka, Japan	76	"15
Berkeley, California	62	3	Ottawa, Canada	69	10
Bidston, England	75	1	Paisley, Scotland	73	1
Bombay, India	105	2,15	Pavia, Italy	88	7
Budapest, Hungary	91	...	Perth, Western Australia	106	2
Caggiano (Salerno), Italy	99	...	Pilar (Cordoba), Argentina	95	1
Cairo (Helwan), Egypt	104	1	Pola, Austria	94	...
Calamate, Greece	102	15	Ponta Delgada, Azores	73	"i
Calcutta, India	105	1	Porto Rico (Vieques)	71	8
Cape of Good Hope, Africa	107	1	Potsdam, Germany	81	4,5
Carloforte, Sardinia, Italy	97	...	Quarto-Castello (Florence), Italy	94	6
Carson City, Nevada	65	"3	Rio de Janeiro, Brazil	101	...
Catania, Italy	101	13	Rocca di Papa, Italy	96	14
Cheltenham, Maryland	70	8	Sal6, Italy	89	...
Christchurch, New Zealand	103	...	San Fernando, Spain	85	"i
Cleveland, Ohio	68	"3	San Jose, California	63	3
Coimbra, Portugal	82	1	Sarajevo, Bosnia	97	15
Dorpat (Jurjew), Russia	78	10	Shide, England	76	7,12
Edinburgh, Scotland	74	1	Sitka, Alaska	66	11
Fiume, Hungary	92	...	Sofia, Bulgaria	100	13
Florence (Ximeniano), Italy	93	"Q	Strassburg, Germany	84	14
Florence (Quarto-Castello), Italy	94	6	Tacubaya, D. F., Mexico	67	9
Göttingen, Germany	81	12	Tadotsu, Japan	104	...
Granada, Spain	87	14	Taihoku, Formosa	99	"is
Hamburg, Germany	78	...	Taschkent, Turkestan	102	2,13
Honolulu, Hawaiian Islands	68	2	Tiflis, Russia	102	...
Irkutsk, Siberia	79	2,2a,13	Tokyo, Japan	74	"i
Ischia (Grande Sentinella), Italy	98	7	Toronto, Canada	68	...
Ischia (Porto d'Ischia), Italy	98	7	Tortosa, Spain	86	...
Jena, Germany	83	11	Triest, Austria	90	...
Jurjew (Dorpat), Russia	78	10	Trinidad, West Indies	72	...
Kew, England	77	1	Uccle, Belgium	78	2a
Kobe, Japan	77	5	Upsala, Sweden	75	9
Kodaikanal, India	106	2	Urbino, Italy	95	...
Krukau, Austria	87	13	Victoria, British Columbia	66	"i
Kremsmünster, Austria	86	2	Vienna, Austria	89	9
Laibach, Austria	90	...	Washington, District of Columbia	69	8
Leipzig, Germany	82	...	Wellington, New Zealand	102	2
Los Gatos, California	64	3	Yountville, California	62	3
Manila, Philippine Islands	103	4	Zagreb (Agram), Hungary	93	...
Mauritius	107	2	Zi-ka-wei, China	95	15

## BERKELEY, CALIFORNIA.

Students' Astronomical Observatory of the University of California. Prof. A. O. Leuschner, director.  
 Lat.  $37^{\circ} 53' N.$ ; long.  $122^{\circ} 16' W.$ ; altitude, 97 meters; distance,  $0.46^{\circ}$  or 51 km.; direction, S.  $68^{\circ} E.$   
 Foundation, solid rock.  
 Seismograms, sheet No. 3.

The instruments used were (1) Ewing three-component seismograph, (2) Ewing duplex pendulum, V, 4. The recording plate of the three-component seismograph was raised off its bearings and failed to revolve, and the brackets recording horizontal motion were so disarranged that no reliable record was made; but the weight recording vertical motion showed a maximum displacement just within the range of the instrument, namely, 76 mm., and as the magnifying power was 1.7, and the friction so great that it was practically dead-beat, we may fairly conclude that the maximum vertical range of the ground was about 45 mm., and the amplitude half as much.

The duplex pendulum record is greatly confused and much affected by the stops which limit the displacement of the pendulum; but by a careful study of a greatly magnified record, Professor Leuschner has succeeded in working out the early part of the motion which is reproduced separately on the left of the complete seismogram. The directions on the seismograms show the directions of the earth's movements. As the magnifying power is 4, we see that there was first a movement of the earth of 4.5 mm. towards the east, that is, away from the origin, followed by a movement of 6.5 mm. to the north. It then swung towards the west and back to the southeast. The character of the movement from this point can be more easily understood from the seismogram than from a verbal description; it is soon lost in the confused record which shows a great deal of irregularity; this must, however, partly be due to the influence of the stops which limit the movements of the pendulum. The stops limited the motion so that an earth-amplitude of only 11 mm. was recorded, far less than was actually experienced.

## OAKLAND, CALIFORNIA.

Chabot Observatory. Prof. Charles Burckhalter, director.  
 Lat.  $37^{\circ} 48' N.$ ; long.  $122^{\circ} 17' W.$ ; altitude,  $4 \pm$  meters; distance,  $0.48^{\circ}$  or 53 km.; direction, S.  $59^{\circ} E.$   
 Foundation, alluvium.  
 Seismograms, sheet No. 3.

The instrument used was a Ewing duplex pendulum, V, 4. The seismogram is too confused to give details; but we see clearly that the movement of the pendulum was limited by the nature of the instrument; the movement seems to have been in nearly all directions, and more or less irregular, tho this irregularity was undoubtedly in part due to the pendulum's striking against the side of the case. The beginning of the movement can not be made out on the seismogram. The earth-amplitude recorded is only 10 mm., much less than was actually experienced.

## YOUNTVILLE, CALIFORNIA.

Veterans' Home. F. M. Clarke, superintendent.  
 Lat.  $38^{\circ} 24' N.$ ; long.  $122^{\circ} 22' W.$ ; altitude, 50 meters; distance,  $0.49^{\circ}$  or 54 km. direction, N.  $45^{\circ} E.$   
 Foundation, alluvium over trachite.  
 Seismograms, sheet No. 3.

The instrument used was a simple pendulum about a meter long, the bob weighing 8.15 kg. A long pin passes freely thru a vertical hole in the middle of the bob and records on smoked glass below, with very little friction.  $V, 1.1 \pm$ .

The reproduced seismogram represents the record as it was made by the pendulum. If the pendulum had remained stationary, the movements of the earth would have been just opposite to the recorded movements of the pendulum; but the record is complicated by the free swinging of the pendulum, which was subjected to little friction. The beginning of the movement can not be determined from the seismogram; but from observation of a swinging electric light Mr. Clarke reports it as north to south. The seismogram shows a movement in the northwest-southeast quadrants with a fairly uniform amplitude of 25 mm. The direction of the pendulum's swing changes, but shows little rotatory motion. Singularly, there is no large motion in the northeast-southwest quadrants, the motion in this direction being represented by an elliptic swing with its long axis directed to the northeast, but with only one-third the amplitude of the larger motion. The smallness of the friction, and the lack of exact information regarding the period of the waves, make it impossible to determine the true amount of the earth's motion.

Mr. Clarke gives the following account of the disturbance:

"The first motion was a tremor that swiftly increased in intensity from north to south, and was quickly compounded into a twisting motion accompanied with severe upward thrusts, a 'churning motion.' Then followed a jerky easterly and westerly motion, without the upward thrust, and again the twist; at the end the motion seemed to be southeasterly and northwesterly. Houses were jerked upward. Chimneys were thrown down at the latter part of the shock."

It is curious that the pendulum did not indicate more clearly the existence of rotatory motion; and it is still more curious that there was so little motion in a northeasterly direction, the direction of propagation of the disturbance.

#### ALAMEDA, CALIFORNIA.

Mills College Observatory. Prof. Josiah Keep, director.

Lat.  $37^{\circ} 47' N.$ ; long.  $122^{\circ} 11' W.$ ; distance,  $0.55^{\circ}$  or 61 km.; direction, S.  $61^{\circ} E.$   
Seismograms, sheet No. 3.

The instrument used was a Ewing duplex pendulum; mechanical registration on smoked glass;  $V, 4.$

The seismogram shows a confused record with the beginning undetermined. The marking point has jumped and must have been caught beyond the glass plate, as the record is evidently incomplete. The recorded amplitude corresponds to an earth-amplitude of 10 mm., but it must have been much greater.

#### SAN JOSE, CALIFORNIA.

University of the Pacific. Prof. J. Culver Hartzell.

Lat.  $37^{\circ} 20' \pm N.$ ; long.  $121^{\circ} 55' \pm W.$ ; altitude,  $25 \pm$  meters; distance,  $1.01^{\circ}$  or 112 km.; direction, S.  $45^{\circ} E.$

Foundation, alluvium.

Seismograms, sheet No. 3.

The instrument used was a Ewing duplex pendulum,  $V, 4.$

The beginning of the movement is probably contained in the blur near "W," but it is impossible to determine in what direction the pointer moved from this spot; the pointer must have caught, for the seismogram evidently represents but a small part of the disturbance. The recorded amplitude corresponds to an earth-amplitude of 10 mm.; but it must have been much greater.

## LOS GATOS, CALIFORNIA.

Private observatory. Irving EL Snyder.

Lat.  $37^{\circ} 14' N.$ ; long.  $121^{\circ} 59' W.$ ; distance,  $1.04^{\circ}$  or 115 km.; direction, S.  $38^{\circ} E.$

Foundation, on soil not far from solid rock.

Seismograms, sheet No. 3.

The instruments used were Rocker seismographs. Two lead bars are each supported at the center of two thin circular segments, so that they rock easily on a smooth plate, one in a north-south, and one in an east-west direction. The movements of these rockers are recombined by means of levers and a record is made on smoked glass entirely analogous to the records of a Ewing duplex pendulum. The movement of the earth was magnified about four times.

The arrows show the directions of the motions. If the marking point is supposed stationary, it would be necessary to interchange the directions north and south, east and west, in order to represent the true movement of the earth. The movement seems to have begun in the blurred mark near the middle of the seismogram and the first distinct movement of the pointer was towards the west, and therefore the first distinct movement of the earth was towards the east. This was followed by movements in various directions; the violence of the disturbance quickly disarranged the rockers, and the record is very incomplete. The recorded earth-amplitude is only 5 mm.; but this was much less than the real maximum.

## MOUNT HAMILTON, CALIFORNIA.

Lick Observatory. Prof. W. W. Campbell, director.

Lat.  $37^{\circ} 20' N.$ ; long.  $121^{\circ} 39' W.$ ; altitude, 4,210 meters; distance,  $1.16^{\circ}$  or 129 km.; direction, S.  $53^{\circ} E.$

Foundation, solid rock; the observatory is on the summit of Mount Hamilton.

Seismograms, sheet No. 3.

The instruments used were: (1) Ewing three-component seismograph; *V*: north-south component, 4.2; east-west component, 4; vertical component, 1.8. The reproduced seismogram is only half the size of the original and therefore it only magnifies the displacements half as much as indicated above.

(2) Ewing duplex pendulum, *V*, 4. In reading the actual movement of the ground from the duplex record we must interchange the directions east and west. Both instruments record on smoked glass. The duplex record shows that the earth first moved for a distance of 7 mm. in a direction S.  $60^{\circ} E.$ ; that is, away from the origin; this was followed with some irregularity, by several vibrations parallel with this direction, with increasing amplitude, and then the movement became confused; there was much jumping of the pen, and as much of the movement was not recorded, the pen must have been held off the plate. Unfortunately we can not say positively when the movement recorded on this instrument began, but its amplitude makes it most probable that it began at the same time as the record on the other instrument, namely at  $5^h 12^m 45^s$ .

Altho the earthquake was first felt at Mount Hamilton at  $5^h 12^m 12^s$ , the Ewing three-component seismograph was not set in motion until  $5^h 12^m 45^s$ ; that is, it was started by the violent shock. This was the nearest instrument to the centrum that was driven by a clock and which separated the various phases of the shock. We note that for 9 seconds the disturbance was comparatively slight and then came the strong movement which carried the pens beyond the limits of the glass plate. The north-south component was soon caught and, with the exception of one spasmodic swing across the plate, did not record again for 1 minute 40 seconds, by which time the disturbance had very much diminished. The east-west component seems to have been better placed, for altho

the pen swung well off the plate, it does not seem to have been caught for more than a few seconds at a time. The vertical component recorded but little even during the earlier phase, and when the heavy shock began, 9 seconds after the beginning, it was so deranged that it became permanently caught and incapable of vibrating, so that its record is simply a circle on the plate. The seismogram shows that there were at first two complete vibrations in a direction about northwest and southeast; the period of the first was about 1 second, that of the second about 4 seconds. The first movement was towards the southeast and amounted to 7 mm.; the second movement in that direction was twice as far. The vertical movement was first upward and amounted to about 15 mm.; the period was about twice as long as that of the horizontal motion. But this may be due to derangement by the shock. This shows quite clearly that the first movement of the ground was directed away from the origin of the shock.

At the beginning of the strong motion, at 5<sup>h</sup> 12<sup>m</sup> 54<sup>s</sup>, the vibration had a period of about 2 seconds which soon increased to 4 or 5 seconds and, at times, was even as great as 10 seconds. The north-south component, as recorded at 5<sup>h</sup> 13<sup>m</sup> 12<sup>s</sup>, shows an earth-amplitude of 4 cm. The maximum east-west amplitude recorded was about the same. The beginning of the strong movement was directed towards the northwest.

#### CARSON CITY, NEVADA.

Carson Observatory. Prof. C. W. Friend, director.<sup>1</sup>

Lat. 39° 10' N.; long. 119° 46' W.; altitude, 1,420 meters; distance, 2.62° or 291 km.; direction, N. 64° E.

Seismograms, sheet No. 3.

The instrument used was a Ewing duplex pendulum, V, 4.

Altho the seismogram shows movements in all directions, it differs very materially from the seismograms of similar instruments nearer the origin. We do not find the sudden and irregular changes in direction, but the changes are rather gentle. At this distance from the origin the disturbance had become a gentle swing with a period of about 3 seconds.

Professor Friend gave the time of arrival of the disturbance as 5<sup>h</sup> 12<sup>m</sup> 25<sup>s</sup>. This is 3 seconds before the occurrence of the heavy shock; and we are led to the inquiry whether it may not refer to the earlier light disturbance, which occurred at 5<sup>h</sup> 11<sup>m</sup> 58<sup>s</sup>. This, however, is negatived by two facts. If the first disturbance was felt at Carson City, the violent shock, which was many times stronger, should have been felt at a far greater distance, whereas Winnemucca and Eureka, about twice as far from the origin as Carson City, are the most distant points where the disturbance was noticed, and the intensity at these places was so much less than at Carson City, that we must suppose they all felt the same disturbance; it does not seem possible that Carson City could have felt the earlier and lighter shock and that the violent shock was not felt at far greater distances than Winnemucca and Eureka. Again, if Carson City felt the earlier shock at 5<sup>h</sup> 12<sup>m</sup> 25<sup>s</sup>, 27 seconds after its occurrence, the velocity of transmission would have been 291/27 or 10.8 km./sec. This is greater than can be admitted, for the velocity of transmission increases with the distance measured along the chord, and the velocity for points ten times as far from the origin as Carson City is only about 8.5 km./sec. We are obliged either to suppose that there is an error in the time report from Carson City, or that a light local shock occurred in its neighborhood a few seconds before the violent shock occurred on the coast. The latter could not have been felt at Carson City before 5<sup>h</sup> 13<sup>m</sup>, and as there is no record there of two disturbances the supposition of a local shock seems improbable. It is very unfortunate that we can not use the Carson City observations to determine the velocity of propagation of the earthquake disturbance.

---

<sup>1</sup> Professor Friend died in January, 1907.

## VICTORIA, BRITISH COLUMBIA.

Meteorological Office. R. F. Stupart, F. R. S. C, director; E. Baynes Reed, superintendent.

Lat.  $48^{\circ} 27' N.$ ; long.  $123^{\circ} 22' W.$ ; altitude, not much above sea-level; distance,  $10.41^{\circ}$  or 1,157 km.; chord, 1,155 km.; direction, N.  $20^{\circ} W.$

Foundation, solid rock.

Seismograms, sheet No. 1.

The instrument used was a Milne horizontal pendulum, east component; photographic registration.  $T_0$ , 15 seconds;  $V$ , 6.1;  $J$ , 330 meters; angular displacement, 1 mm. = 0.76";  $M$ , 255 gm.;  $L$ , 15.6 cm.

East component: First preliminary tremors,  $14.2^m$ ; second preliminary tremors,  $14.7^m$ ; maximum,  $17.1^m$ ; amplitude, 17+ mm.

There seems to have been a reinforcement of the motion at  $15.2^m$ , and at  $16.1^m$  the motion was strong enough to join the records from opposite sides of the seismogram; that is, the amplitude of the pointer exceeded 17 mm.; this continued with slight interruptions for 11 minutes, and then diminished with many irregularities; If Victoria recorded only the violent shock, the velocity of propagation would have been  $1,155/104 = 11.1$  km./sec, which is far too great; we must therefore believe that the beginning of the record refers to the earlier and lighter motion that began at  $5^h 11^m 58^s$  at a point 25 km. further from Victoria. The velocity would then be  $1,181/134 = 8.8$  km./sec, which is a little but not much larger than might be expected. The beginning of the strong motion on the seismogram, coming a half minute after the beginning of the record, occurs too early for the long waves from the earlier disturbance, and too early even for the second preliminary tremors. It must represent the first preliminary tremors of the violent shock, whose velocity would then be  $1,155/134 = 8.6$  km./sec. We thus get two records of the velocity of the first preliminary tremors; which agree very well when we consider the difficulty of determining the exact point on the seismogram where the movements begin, and the further difficulty of reading the corresponding time as near as a tenth of a minute. The strong motion, beginning at  $16.1^m$ , would correspond in time to the arrival of the second preliminary tremors of the earlier shock, but as this shock was not felt in Sitka it does not seem possible that it could have made so great a record in Victoria, even tho the latter recorded especially the transverse vibrations and the former the longitudinal. The remainder of the record is complicated by the overlapping of vibrations coming apparently from different parts of the fault-plane.

## SITKA, ALASKA.

Magnetic Station of U. S. Coast and Geodetic Survey. O. H. Tittmann, superintendent; Dr. H. M. W. Edmonds, magnetic observer.

Lat.  $57^{\circ} 03' N.$ ; long.  $135^{\circ} 20' W.$ ; altitude, 15 meters; distance,  $20.72^{\circ}$  or 2,303 km.; chord, 2,291 km.; direction, N.  $19^{\circ} W.$

Foundation, directly on solid rock.

Seismograms, sheet No. 11.

The instrument was a Bosch-Omori horizontal pendulum, north component; mechanical registration on smoked paper.  $T_0$ , 14 seconds;  $V$ , 10;  $J$ , 490 meters;  $e$ , 1.0;  $r$ , 1.0 mm.;  $M$ , 10 kg.;  $L$ , 75cm.

	FIRST PRELIMINARY TREMORS.		SECOND PRELIMINARY TREMORS.		REGULAR WAVES.		MAX.				AMPLITUDE.
	<i>m.</i>	<i>«.</i>	<i>m.</i>	<i>s.</i>	<i>m.</i>	<i>«.</i>	<i>m.</i>	<i>s.</i>	<i>m.</i>	<i>».</i>	<i>mm.</i>
North component	17	02	21	06	22	32	23	30	to 30	20	65 +
Interval . . .	4	34	8	38	10	04					



There were no regular time marks on the seismograms, but certain marks have been made artificially, which enable us to make fair estimates of the times.

The motion begins very gently at 17<sup>m</sup> 02<sup>s</sup>; at 17<sup>m</sup> 32<sup>s</sup> a stronger movement occurs, which dies down in a little over a minute; it is possible that this is the true beginning of the first preliminary tremors; at the beginning and soon after the end of this movement there were east-west jars which shook the recording drum and caused an overlapping of the record. The beginning of the second preliminary tremors is about 21<sup>m</sup> 06<sup>s</sup> with an amplitude of 11 mm. This continued with some irregularity until 22<sup>m</sup> 32<sup>s</sup>, when the marker went beyond the limits of the paper, i.e., with an amplitude greater than 65 mm. The strong motion lasted about 14.5 minutes to 13<sup>h</sup> 36<sup>m</sup>, and then the movement continued with small amplitude and occasional reinforcements until about 15<sup>h</sup> 17<sup>m</sup>. It is not unlikely that the times at Sitka are all about a half-minute too late; this correction would make them accord better with observations from other stations in drawing the hodographs.

The damping is entirely negligible; and the solid friction is not large. The period during the large motion is practically that of the pendulum, so that it is impossible to estimate the magnification, or the actual movement of the earth.

The question arises: Did Sitka, like Victoria, record the early slight shock or only the violent shock? If it recorded the early shock, the average velocity from the origin would have been  $2,316/304 = 7.63$  km./sec; but since this shock reached Victoria at 14.2<sup>m</sup>, it must have progressed from that neighborhood to Sitka at a rate of about  $(2,316 - 1,180)/170 = 6.7$  km./sec. We can not believe that the disturbance advanced for the first half of the distance to Sitka at a rate of 8.8 km./sec, and for the second half only at a rate of 6.7 km./sec. We are, therefore, obliged to believe that Sitka, which recorded the component at right angles to that recorded at Victoria, really recorded only the violent shock; the velocity for which then becomes  $2,291/274 = 8.36$  km./sec, which is about the velocity we should expect.

#### TACUBAYA, D. F., MEXICO.

Observatorio Astronomico Nacional. Señor F. Valle, director.  
 Lat. 19° 24' N.; long. 99° 12' W.; altitude, 2,280 meters; distance, 27.70° or 3,081 km.;  
 chord, 3,050 km.; direction, S. 54° E.  
 Foundation, alluvium.  
 Seismograms, sheet No. 9.

The instruments used were Bosch-Omori horizontal pendulums, two horizontal components; mechanical registration on smoked paper.

- (1) North component:  $T_0$ , 17.3 seconds;  $J$ , 1,120 meters;  $A_f$ , 10 kg.;  $L$ , 75 em.  
 (2) East component:  $T_0$ , 17.6 seconds;  $V$ , 15;  $I$ , 1,100 meters;  $M$ , 10 kg.;  $L$ , 75 em.

	FIRST PRELIMINARY TREMORS.	SECOND PRELIMINARY TREMORS.	REGULAR WAYES.	PRINCIPAL PAST.	MAX.	AKPUTIDX.	Praia@.
	m. s.	m. s.	TO. s.	m. t.	m. s.	mm.	
(1) North component	17 58	22 50	25 08	26 40	26 45	60 +	15-25
(2) East component	17 58	22 54	25 06	25 50	26	80 +	
Average . . .	17 58	22 52	25 37	26 45			
Interval . . .	5 30	10 24	13 09	13 37			

The second phase is much stronger on the east component than on the north component, which is due to synchronism of periods; and the long waves begin more definitely on the east component.

The periods during the strong motion approach those of the pendulums and therefore we can not estimate the earth's movement; the fact that the marker goes beyond the limits of the record very near the beginning of the strong motion shows, however, that the earth's displacement was large.

## CLEVELAND, OHIO.

St. Ignatius College Observatory. Rev. F. L. Odenbach, S. J., director.  
 Lat.  $41^{\circ} 29' N.$ ; long.  $81^{\circ} 42' W.$ ; altitude, 230 meters; distance,  $31.47^{\circ}$  or 3,498 km.;  
 chord, 3,456 km.; direction, N.  $71^{\circ} E.$   
 Foundation, stiff clay.  
 Seismograms, sheet No. 3.

The instrument used was a heavy pendulum, prevented from swinging by four carbon rods pressing against it in directions  $90^{\circ}$  apart. Electric currents pass thru the carbons and the pendulum and then thru carefully balanced solenoids, which carry pens marking on white paper. At the time of a shock the pressure of the pendulum against the carbons, and hence the currents, vary, and the marking pens are displaced, making a record. The preliminary tremors can not be made out; but the principal part begins about  $13^h 29.4^m$ .

## TORONTO, CANADA.

Meteorological Office. R. F. Stupart, F. R. S. C, director.  
 Lat.  $43^{\circ} 40' N.$ ; long.  $79^{\circ} 23' E.$ ; altitude, 107.5 meters; distance,  $32.93^{\circ}$  or 3,571 km.; chord, 3,610 km.; direction, N.  $66^{\circ} R$   
 Foundation, boulder clay, 32 meters above Lake Ontario.  
 Seismograms, sheet No. 1.

The instrument used was a Milne horizontal pendulum, east component; photographic registration.  $T_o$ , 14.8 seconds;  $V$ , 6.1;  $J$ , 330 meters;  $e$ , 1.051; angular displacement, 1 mm. = 0.66";  $M$ , 255 gm.;  $L$ , 15.6 cm.

	FIRST PRELIMINARY TREMORS.	SECOND PRELIMINARY TREMORS.	REGULAR WAVES.	MAX.	AMPLITUDE.
East component . . . . .	<i>min.</i> 19.3	<i>min.</i> 24.5	<i>min.</i> 27.9	<i>min.</i> 33.3	<i>mm.</i> 17 +
Interval . . . . .	6.8	12.0	15.4		

Beginning given as  $19.3^m$ ; intensified at  $24.5^m$ ; and again at  $27.6^m$ ; at  $32.0^m$  the records join from opposite sides, *i.e.*, the amplitude was greater than 17 mm. This continues with one interruption for 10 minutes. The motion dies down considerably, but at  $55.0^m$  the sides again join for 2 minutes with one small interruption. The remainder of the record is subsiding. The period during the strong motion can not be determined from the seismogram on account of the close time scale, but from records at other stations it could not be very different from that of the pendulum, and this accounts in part for the large amplitude.

## HONOLULU, HAWAIIAN ISLANDS.

Magnetic Observatory of U. S. Coast and Geodetic Survey. O. H. Tittmann, superintendent; S. A. Deel, magnetic observer.  
 Lat.  $21^{\circ} 19' N.$ ; long.  $158^{\circ} 04' W.$ ; distance,  $34.60^{\circ}$  or 3,846 km.; chord, 3,790 km.;  
 direction, S.  $71^{\circ} W.$   
 Foundation, directly on solid coral rock.  
 Seismograms, sheet No. 2.

The instrument used was a Milne horizontal pendulum, east component; photographic registration.  $T_o$ , 19 seconds;  $V$ , 6.1;  $J$ , 560 meters;  $M$ , 255 gm.;  $L$ , 15.6 cm.

	FIRST PRELIMINARY TREMORS.	SECOND PRELIMINARY TREMORS.	MAX.	AMPLITUDE.
East component . . .	<i>min.</i> 19.5	<i>min.</i> 24.4	<i>min.</i> 26.2 to 28.2	<i>mm.</i> 17 +
Interval . . .	7.0	11.9	28.9 to 32.1	17 +

The instrument was not perfectly still and the time of the beginning is difficult to determine. The time given is that of the observer in charge. There is a well-marked movement 0.6 minute later, which may mark the arrival of waves reflected once internally at the earth's surface. The time of arrival of the long waves is not definite. There are large vibrations at 26.6<sup>m</sup> and others at 29.1<sup>m</sup>; the latter fit the hodograph of the regular waves, but they are too uncertain and have not been used.

## OTTAWA, CANADA.

Astronomical Observatory. Dr. Otto J. Klotz, director.

Lat. 45° 24' N.; long. 75° 43' W.; altitude, 82 meters; distance, 35.37° or 3,932 km.; chord, 3,871 km.; direction, N. 62° E.

Foundation, boulder clay.

Seismograms, sheet No. 10.

The instruments used were Bosch-Omori horizontal pendulums, two horizontal components; photographic registration.

(1) North component:  $T_0$ , 5.71 seconds;  $V$ , 120;  $J$ , 970 meters;  $e$ , 1.50;  $r$ , 0.0 mm.;  $M$ , 200 gm.;  $L$ , 6.68 cm.

(2) East component:  $T_0$ , 7.06 seconds;  $V$ , 120;  $J$ , 1,500 meters;  $e$ , 1.76;  $r$ , 0.0 mm.;  $M$ , 200 gm.;  $L$ , 6.68 cm.

	FIRST PRELIMINARY TREMOBB.	SECOND PRELIMINARY TREMORS.	PRINCIPAL PART.
(1) North component . . .	<i>m.</i> 19 <i>a.</i> 25	<i>m.</i> 24 <i>a.</i> 50	<i>m.</i> 30 <i>a.</i> 40
(2) East component . . .	19   12	..   ..	31   20(?)
Average . . . . .	19   19	24   50	31.0
Interval . . . . .	6   51	12   22	18.5

The east component began 13 seconds before the north; this indicates that the longitudinal motion began before the transverse. The north earth-amplitude (one minute after the beginning) was 0.004 mm.; and the east earth-amplitude (0.5 minute after beginning) was 0.005 mm. These values are somewhat uncertain on account of the closeness of periods. The periods of the waves are not very different from that of the pendulums. On the north component the motion became so large for 10 minutes after 31.0<sup>m</sup> that it can not be followed; it then dies down to quiet at about 16<sup>h</sup> 30<sup>m</sup>. On the east component the records are superposed so that the phases can not be distinguished after the beginning.

## WASHINGTON, DISTRICT OF COLUMBIA.

U. S. Weather Bureau. Prof. Willis L. Moore, chief; Prof. C. F. Marvin in charge of seismographs.

Lat. 38° 54' N.; long. 77° 03' W.; altitude, 20.5 meters; distance, 35.44° or 3,939 km.; chord, 3,878 km.; direction, N. 74° E.

Foundation, firm clay and gravel; solid rock probably within 8 meters.

Seismograms, sheet No. 8.

The instrument used was a Bosch-Omori horizontal pendulum; east component; mechanical registration on smoked paper.  $T_0$ , 32 seconds,  $V$ , 10;  $J$ , 2,540 meters;  $e$ , 1.35;  $r$ , 0.56 mm.;  $M$ , 17.35 kg.;  $L$ , 75.2 cm.

	FIRST PRELIMINARY TREMORS.	SECOND PRELIMINARY TREMORS.	REGULAR WAVES.	PRINCIPAL PART.	MAX.	AMPLITUDE.
East component	<i>m.</i> <i>a.</i> 19 20	<i>m.</i> <i>s.</i> 25 00	<i>m.</i> <i>a.</i> 29 20	<i>min.</i> 30.5	<i>min.</i> 32 to 35	<i>mm.</i> 95
Interval	6 52	12 32	16 52	18.0		

Duration, 4.3 hours. Perhaps the long waves should begin a minute earlier. The very strong motion only lasted about 4.5 minutes. During the second preliminary tremors the period was about 25 seconds, and amplitude 95 mm., corresponding to an earth-amplitude of 0.4 mm. During the regular waves at 32.0<sup>m</sup> when the pointer went off the record, the period was about 30 seconds, practically that of the pendulum; so that we can not draw conclusions regarding the actual motion of the ground.

CHELTENHAM, MARYLAND.

Magnetic Observatory of U. S. Coast and Geodetic Survey. O. H. Tittmann, superintendent; W. F. Wallis, magnetic observer.

Lat. 38° 44' N.; long. 76° 50.5' W.; altitude, 72 meters; distance, 35.64° or 3,962 km.; chord, 3,899 km.; direction, N. 74° E.

Foundation, sands and gravel.

Seismograms, sheet No. 8.

The instruments used were Bosch-Omori horizontal pendulums, two horizontal components; mechanical registration on smoked paper. The corrections to G. M. T. are negative for both components.

(1) North component:  $T_0$ , 20 seconds;  $V$ , 10;  $J$ , 1,000 meters;  $M$ , 10 kg.;  $L$ , 75 cm.

(2) East component:  $T_0$ , 25 seconds;  $V$ , 10;  $J$ , 1,560 meters;  $M$ , 10 kg.;  $L$ , 75 cm.

	FIRST PRELIMINARY TREMORS.	SECOND PRELIMINARY TREMORS.	REGULAR WAVES.	PRINCIPAL PART.	PERIOD.	AMPLITUDE.
(1) North component	<i>m.</i> <i>s.</i> 19 30	<i>m.</i> <i>s.</i> 25 01	<i>to.</i> <i>s.</i> 30 00	<i>min.</i> 32.3 to 36	<i>sec.</i> 13	<i>mm.</i> 40 +
(2) East component	19 16	25 09	30 32	32.8 to 39	9	35 +
Average	19 23	25 05	30 16	32.5		
Interval	6 55	12 37	17 48	20.0		

Duration, north, 2.7 hours; east, 3.1 hours. The time of the first preliminary tremors on north component is not very definite, but it is not later than 19<sup>h</sup> 30<sup>m</sup>. The longitudinal waves apparently arrived some seconds earlier than the transverse. This probably means that the longitudinal waves were first felt, and then the disturbance became more complex. The regular waves are a little earlier on the north than on the east component, as is also the strong motion.

The dying-out curves sent me to determine the damping and friction are too irregular to yield definite results, which is probably due to irregular friction; but if we neglect the damping and frictional terms, we find the magnifying power of the north component for waves of period 13 seconds (13<sup>h</sup> 34<sup>m</sup>) to be 17.3; and since the amplitude of the pendulum is 40 mm. that of the earth would be 2.3 mm.; with the same assumption, the magnifying power of the east component for waves of period 9 seconds (13<sup>h</sup> 36<sup>m</sup>) is 11; and the corresponding earth-amplitudes, 3.2 mm. But both of these values are too small, as the movements of the pendulums seem to have been limited by the stops. It is not unlikely that the total earth-amplitude at Cheltenham may have amounted to 5 mm.

## BALTIMORE, MARYLAND.

Johns Hopkins University. Prof. Harry Fielding Reid, in charge of seismographs.  
Lat.  $39^{\circ} 18' N.$ ; long.  $76^{\circ} 37' W.$ ; altitude, 30 meters; distance,  $35.74^{\circ}$  or 3,973 km.;  
chord, 3,909 km.; direction, N.  $73^{\circ} E.$

Foundation, clays and gravels, about 30 meters thick, resting on rock.

Seismograms, sheet No. 1.

The instrument used was a Milne horizontal pendulum; component, N.  $60^{\circ} W.$ ; photographic registration. TQ, 14 seconds;  $1^{\wedge}, 6.1$ ; J, 300 meters; e, 1.03; r, 0.0mm.; angular displacement, 1 mm. = 0.83"; M, 255 gm.; L, 15.6 cm.

	FIRST PRELIMINARY TREMORS.	SECOND PRELIMINARY TREMORS.	PRINCIPAL PART.	MAX.	AMPLITUDE.
N. $60^{\circ} W.$ component	<i>min.</i> 19.4	<i>min.</i> 25.2	<i>min.</i> 31.6	<i>min.</i> 31.8 to 39.1	<i>mm.</i> 17 +
Interval . . . . .	6.9	12.7	19.1		

If we assume that the wave period at Baltimore was the same as that at Cheltenham, namely, 13 seconds, we see that the large amplitude at this station is due to synchronism of periods of the waves and the pendulums.

## ALBANY, NEW YORK.

New York State Museum. Dr. John M. Clarke, State geologist.

Lat.  $42^{\circ} 39' N.$ ; long.  $73^{\circ} 45' W.$ ; altitude, 26 meters; distance,  $37.13^{\circ}$  or 4,128 km.;  
chord, 4,056 km.; direction, N.  $67^{\circ} E.$

Foundation, heavy blue clay with interbedded sand and gravel.

Seismograms, sheet No. 8.

The instruments used were Bosch-Omori horizontal pendulums, two horizontal components; mechanical registration on smoked paper. Constants for both components:  $T_0$ , 30 seconds; V, 10;  $\lambda$ , 2,240 meters; M, 11.28 kg.; L, 85.5 cm.

	FIRST PRELIMINARY TREMORS.	SECOND PRELIMINARY TREMORS.	REGULAR WAVES.	PRINCIPAL PART.	MAX.	AMPLITUDE.
(1) North component	<i>m.</i> 21 <i>s.</i> 30	<i>m.</i> 29 <i>s.</i> 04	<i>m.</i> 33 <i>s.</i> 00	<i>min.</i> 33.5 to 35.5	<i>m.</i> 34 <i>s.</i> 30	<i>mm.</i> 32
(2) East component	<i>m.</i> 21 <i>s.</i> 30	<i>m.</i> 28 <i>s.</i> 00	<i>m.</i> 32 <i>s.</i> 30	<i>min.</i> 34.0 to 42	<i>m.</i> 34 <i>s.</i> 40	<i>mm.</i> 22
Average . . . . .	21 30	28 32	32 45	33.7		
Interval . . . . .	9 02	16 04	20 17	21.2		

Duration, north, 2.1 hours; east, 2.7 hours. The times of the preliminary tremors are two or three minutes too late. The strong motion on the east component lasted about 9 minutes, on the north component only 2 minutes; but the greatest amplitude was shown by the latter. The strong motion was not regular nor long enough to estimate the amplitudes of the earth's motion.

## PORTO RICO (VIEQUES), WEST INDIES.

Magnetic Observatory of U. S. Coast and Geodetic Survey. O. H. Tittmann, superintendent; P. H. Dike, magnetic observer.

Lat.  $18^{\circ} 08' N.$ ; long.  $65^{\circ} 26' W.$ ; altitude, 40 meters; distance,  $53.45^{\circ}$  or 5,942 km.;  
chord, 5,729 km.; direction, S.  $85^{\circ} E.$

Seismograms, sheet No. 8.

The instruments used were Bosch-Omori horizontal pendulums, two horizontal components; mechanical registration on smoked paper.

(1) North component:  $T_0$  20 seconds;  $V$ , 10;  $J$ , 1,000 meters;  $e$ , 1.066;  $r$ , 3.25 mm.;  $M$ , 11 kg.;  $L$ , 75 cm.

(2) East component:  $T_0$  21 seconds;  $V$ , 10;  $J$ , 1,100 meters;  $e$ , 1.0;  $r$ , 2.6 mm.;  $M$ , 11 kg.;  $L$ , 75 cm.

	FIRST PRELIMINARY TREMORS.		SECOND PRELIMINARY TREMORS.		REGULAR WAVES.	PRINCIPAL PART.	MAX.	AMPLITUDE.
	<i>m.</i>	<i>a.</i>	<i>m.</i>	<i>a.</i>	<i>min.</i>	<i>min.</i>	<i>m.</i>	<i>s.</i>
(1) North component	21	45	30	24	40?	43 to 50?	48	50
(2) East component	21	54	29	50	39?	47.5 to 54.5?	50	0
Average . . . .	21	50	30	07	39.5?			
Interval . . . .	9	22	17	39	27.0?			

Duration, north, 2 hours; east, 2.5 hours. The periods of the waves coincide with periods of the pendulums and the strong motion lasted too short a time to enable an estimate of the earth's motion to be made. There seems to have been a certain amount of separation of the north and east components of the waves, as the strong motion of each occurs when that of the other is much reduced. The regular waves do not appear very definitely.

#### TRINIDAD, BRITISH WEST INDIES.<sup>1</sup>

St. Clair Experiment Station of the Botanical Gardens. J. H. Hart, F. L. S., superintendent.

Lat. 10° 40' N.; long. 61° 30' W.; altitude, 20.5 meters; distance, 60.94° or 6,774 km.; chord, 6,460 km.; direction, S. 80° E.

Foundation, 2 meters of concrete laid on sands and clays.

The instrument used was a Milne horizontal pendulum, east component; photographic registration.  $T_0$ , 18 seconds;  $V$ , 6.1;  $J$ , 490 meters; angular displacement, 1mm. = 0.5";  $M$ , 255 gm.;  $L$ , 15.6 cm.

Preliminary tremors, 11<sup>m</sup>; regular waves, 42<sup>m</sup>; maximum, 53<sup>m</sup>; amplitude, 10<sup>ra</sup>. Interval for regular waves, 29.5 minutes.

The record of the commencement is evidently erroneous. The time of arrival of the regular waves at 42<sup>m</sup> may be fairly correct. Duration 3.2 hours.

#### APIA, SAMOA.<sup>1</sup>

Observatorium der Kgl. Gesellschaft der Wissenschaften in Göttingen. Dr. F. Linke, director.

Lat. 13° 48' S.; long. 171° 46' W.; distance, 69.20° or 7,694 km.; chord, 7,235 km.; direction, S. 52° W.

The instrument used was a Wiechert inverted pendulum (1,000 kg.), two horizontal components; mechanical registration on smoked paper.

First preliminary tremors, 23<sup>m</sup> 22<sup>s</sup>; interval, 10<sup>m</sup> 54<sup>s</sup>.

Second preliminary tremors, 32<sup>m</sup> 24<sup>s</sup>; interval, 19<sup>m</sup> 56<sup>s</sup>.

<sup>1</sup> The data were obtained from Circular 14 of the Seismological Committee of the B. A. A. S.

<sup>2</sup> Information obtained from Wiechert and Zoeppritz, "Ueber Erdbebenwellen"; Nach. Kgl. Gesell. Wissen. Göttingen, Math.-Phys. Kl., 1907.

MIZUSAWA, JAPAN.<sup>1</sup>

Meteorological Observatory.

Lat. 39° 08' N.; long. 141° 07' E.; distance, 70.46° or 7,834 km.; chord, 7,349 km.; direction, N. 55° W.

The instrument used was an Omori horizontal pendulum; mechanical registration on smoked paper.

First preliminary tremors, 24<sup>m</sup> 07<sup>s</sup>; interval, 11<sup>m</sup> 39<sup>s</sup>.

Second preliminary tremors, 33<sup>m</sup> 14<sup>s</sup>; interval, 20<sup>m</sup> 46<sup>s</sup>.

Apia has a Wiechert pendulum which magnifies more than the Omori at Mizusawa and therefore probably showed the movement more promptly.

## PONTA DELGADA, AZORES.

Serviço Meteorológico dos Açores. Major F. A. Chaves, director.

Lat. 37° 44' N.; long. 25° 41' W.; altitude, 16 meters; distance, 72.53° or 8,064 km.; chord, 7,536 km.; direction, N. 55° E.

Foundation, basaltic rock in a volcanic region.

Seismograms, sheet No. 1.

The instrument used was a Milne horizontal pendulum, east component; photographic registration.  $V$ , 6.1; angular displacement, 1 mm. = 0.49";  $M$ , 255 gm.;  $L$ , 15.6 cm.

	FIRST PRELIMINARY TREMORS.	PRINCIPAL PART.	MAX.	AMPLITUDE.
East component . .	<i>min.</i> 23.6	<i>min.</i> 50.5?	<i>min.</i> 54.6	<i>mm.</i> 7.3
Interval . . . .	11.1	38.0?		

Duration, 3.5 hours. The second preliminary tremors are not distinguishable. There is a curious difference between the seismograms of Ponta Delgada and those of Paisley and Edinburgh, at practically the same distance from the origin. In the former, the first preliminary tremors are stronger and the beginning of the second preliminary tremors are not clearly differentiated; in the two latter, the first preliminary tremors are very feeble but the second preliminary tremors begin sharply.

## PAISLEY, SCOTLAND.

Coats Observatory. David Crilley, director.

Lat. 55° 51' N.; long. 4° 26' W.; altitude, 32 meters; distance, 72.54° or 8,065 km.; chord, 7,537 km.; direction, N. 31° E.

Foundation, boulder clay.

Seismograms, sheet No. 1.

The instrument used was a Milne horizontal pendulum, east component; photographic registration.  $T_0$ , 17 seconds;  $V$ , 6.1;  $L$ , 440 meters; angular displacement, 1 mm. = 0.55";  $M$ , 255 gm.;  $L$ , 15.6 cm.

	FIRST PRELIMINARY TREMORS.	SECOND* PRELIMINARY TREMORS.	REGULAR WAVES.	PRINCIPAL PART.	MAX.	AMPLITUDE.
East component . .	<i>min.</i> 23.2	<i>min.</i> 33.3	<i>min.</i> 47.4	<i>min.</i> 51.0 to 0.0	<i>min.</i> 54 to 57	<i>mm.</i> 17 +
Interval . . . .	1(K7)	20.8	34.9	38.5		

Duration, 4.1 hours. The period of the long waves was from 25 to 30 seconds.

<sup>1</sup> Information obtained from "Preliminary Note on the Seismographic Observations of the San Francisco Earthquake," by F. Omori, Bull. Imperial Earthquake Investigation Commission, vol.1, No. 1.

BERGEN, NORWAY.<sup>1</sup>

Seismical Station of the Museum. Prof. Dr. Carl F. Kolderup, director.

Lat. 60° 24' N.; long. 5° 18' E.; altitude, 20 meters; distance, 72.79° or 8,092 km.; chord, 7,560 km.; direction, N. 24° E.

The instruments used were Bosch-Omori horizontal pendulums, two components; mechanical registration on smoked paper; *V*, 15.

	FIRST PRELIMINARY TREMORS.		SECOND PRELIMINARY TREMORS.		PRINCIPAL PART.		MAX.	PERIOD.	AMPLITUDE.
	<i>in.</i>	<i>s.</i>	<i>m.</i>	<i>a.</i>	<i>m.</i>	<i>s.</i>	<i>m.</i>	<i>s.</i>	<i>mm.</i>
(1) North component	22	46	32	09	..	..	54	45	5.0
(2) East component.	22	56	32	20	51	44	55	06	50.0
Average . . .	22	51	32	15	51	44	54	55	
Interval . . .	10	23	19	47	39	16	42	27	

The great difference between the maximum amplitudes is probably due to differences in the periods of the two pendulums.

## EDINBURGH, SCOTLAND.

Royal Observatory. Thomas Heath, director.

Lat. 55° 55.5' N.; long. 3° 11' W.; altitude, 131.5 meters; distance, 72.99° or 8,115 km.; chord, 7,578 km.; direction, N. 31° E.

Foundation, Devonian lava.

Seismograms, sheet No. 1.

The instrument used was a Milne horizontal pendulum, east component.  $T_0$ , 17 seconds; *V*, 6.1; *J*, 440 meters; *e*, 1.11; angular displacement, 1 mm. = 0.54"; *M*, 255 gm.; *L*, 15.6 cm.

	FIRST PRELIMINARY TREMORS.	SECOND PRELIMINARY TREMORS.	REGULAR WAVES.	PRINCIPAL PART.	MAX.	AMPLITUDE.
	<i>min.</i>	<i>min.</i>	<i>min.</i>	<i>min.</i>	<i>min.</i>	<i>mm.</i>
East component . .	23.5	33.0	48.0	52.0 to 05.6	54.2 to 56.7	17 +
Interval . . .	11.0	20.5	35.5	39.5		

Duration, 3.7 hours.

## TOKYO, JAPAN.

Tokyo Imperial University. Prof. F. Omori, D. Sc, director.

Lat. 35° 42.5' N.; long. 139° 46' E.; distance, 73.92° or 8,217 km.; chord, 7,660 km.; direction, N. 57° W.

Seismograms, sheet No. 11.

The instrument used was an Omori horizontal pendulum, east component; mechanical registration on smoked paper.  $T_0$ , 41.5 seconds; *T*, 30; *J*, 1,290 meters; *M*, 16.5 kg.; *L*, 75 cm.

	(a) FIRST PRELIMINARY TREMORS.	(b) SECOND PRELIMINARY TREMORS.	REGULAR WAVES.	(d) PRINCIPAL PART.	MAX.	AMPLITUDE.
	<i>rr.</i> <i>a.</i>	<i>m.</i> <i>s.</i>	<i>w.</i> <i>s.</i>	<i>m.</i> <i>a.</i>	<i>T</i> <i>s.</i> <i>m.</i> <i>s.</i>	<i>mm.</i>
East component	24 35	34 24	46 20	50 15	46 45 to 48 10	93 +
Interval . . .	12 07	21 56	33 52	37 47		

<sup>1</sup> The information was obtained from "Registrierungen an der seismischen Station in Bergen in Jahre 1906," by Carl F. Kolderup. Bergens Museum Aarbog, 1907, 2 Hefte. A mechanical reproduction of the seismogram there is given.



At 15<sup>h</sup> 31<sup>m</sup>, (f), vibrations propagated along major arc, according to Professor Omori. The large amplitudes shown, both at the beginning of the second preliminary tremors and in the long waves are due to approximate synchronism of periods of the waves and the pendulum.

## BIDSTOFr, ENGLAND.

Liverpool Observatory. W. E. Plummer, director.

Lat. 53° 24' N.; long. 3° 04' W.; altitude, 54 meters; distance, 74.81° or 8,317 km.; chord, 7,739 km.; direction, N. 33° E.

Foundation, sandstone.

Seismograms, sheet No. 1.

The instrument used was a Milne horizontal pendulum, east component; photographic registration.  $T_0$ , 18.7 seconds;  $V$ , 6.1;  $\lambda$ , 530 meters;  $e$ , 1.057;  $M$ , 255 gm.;  $L$ , 15.6 cm.

	FIRST PRELIMINARY TREMORS.	SECOND PRELIMINARY TREMORS.	REGULAR WAVES.	PRINCIPAL PART.	MAX.	AMPLITUDE.
East component Interval	<i>min.</i> 24.3 11.8	<i>min.</i> 34.0 21.5	<i>min.</i> 45.2 35.7	<i>min.</i> 51.6 39.1	<i>min.</i> 54.3, 56.3 to 58.2	<i>THU</i> 17+

Duration, 4.1 hours. The regular waves can be recognized by their greater period, which amounts to 24 seconds against 19 seconds during the principal part; this becomes still shorter during the strongest part of the disturbance. A comparison with the seismograms of Edinburgh, Paisley, and Kew also help to identify this phase, tho there is not so marked a change in amplitude at its beginning as in the other seismograms mentioned.

## UPSALA, SWEDEN.

Meteorological Observatory of the University. Prof. Dr. H. H. Hildebrandsson, director.

Lat. 59° 51.5' N.; long. 17° 37.5' E.; altitude, 16 meters; distance, 76.80° or 8,538 km.; chord, 7,914 km.; direction, N. 19° E.

Seismograms, sheet No. 9.

The instrument used was a Wiechert inverted pendulum, two horizontal components; mechanical registration on smoked paper.

(1) North component:  $T_{01}$  6.8 seconds;  $V$ , 230;  $J$ , 2,650 meters;  $\epsilon$ , 3;  $M$ , 1,000 kg.;  $Z$ , 11.5 meters;  $L$ , 1 meter.

(2) East component:  $T_0$ , 5.3 seconds;  $V$ , 270;  $\lambda$ , 1,900 meters;  $e$ , 3;  $M$ , 1,000 kg.;  $U$ , 11.5 meters;  $L$ , 1 meter.

	FIRST PRELIMINARY TREMORS.	SECOND PRELIMINARY TREMORS.	REGULAR WAVES.	PRINCIPAL PART.	MAX.	AMPLITUDE.	PERIOD.
	<i>m. B.</i>	<i>m. «.</i>	<i>m. «.</i>	<i>m. a.</i>	<i>m. a.</i>		<i>sec.</i>
(1) North component	24 51	34 43	50 20	54 05 j	55 00 59 15 02 45	46 50 57	15
(2) East component	24 51	34 45	.. ..	52 00 to 55	54 00	15	
Average	24 51	34 44	50 20	53 02?			
Interval	12 23	22 16	37 52	40 34?			

Duration, 3 hours. The first and second preliminary tremors are especially well defined. The amplitudes of the long waves are about equal on the north and on the east components; what appears to be the principal part on the east corresponds to dying down of regular waves on north. It is curious that the strongest motion of east occurs when

north is weak, and the first strong maximum, at 55<sup>m</sup> of north, is at the weakest part of east. The other north maxima do not correspond to any reënforcement of the east component. The largest earth-amplitude occurred between 13<sup>h</sup> 50<sup>m</sup> and 52<sup>m</sup> and amounted, on the north component, to 3.6 mm.; on the east component, to 3.76 mm. At the maximum displacement of the north needle (14<sup>h</sup> 02<sup>m</sup> 45<sup>s</sup>) the earth-amplitude was only 1.2 mm. and at the maximum displacement of the east needle (13<sup>h</sup> 54<sup>m</sup>) the earth-amplitude was 1.9 mm.; a half minute earlier the north earth-amplitude was 2.8 mm.

#### SHIDE, ISLE OF WIGHT, ENGLAND.

Prof. John Milne, F. R. S., director.

Lat. 50° 41' N.; long. 1° 17' W.; altitude, 15 meters; distance, 77.08° or 8,569 km.; chord, 7,938 km.; direction, N. 34° E.

Foundation, disintegrated chalk over solid chalk.

The instruments used were:

(1) Milne horizontal pendulum, east component. Time scale, 1 mm. to 1 minute.  $T_0$ , 20 seconds;  $V$ , 6.1;  $J$ , 600 meters;  $M$ , 255 gm.; angular displacement, 1 mm. = 0.36";  $L$ , 15.6 cm.

(2) Milne Horizontal Pendulum, east component; time scale, 4.25 mm. to 1 minute. Seismograms, sheet No. 12.  $V$ , 6.1;  $M$ , 255 gm.;  $L$ , 15.6 cm.

Heavy horizontal pendulums, supported by an iron post more than 2 meters high. Seismograms, sheet No. 7.

(3) North component:  $V$ , 25.4;  $e$ , 1.24;  $r$ , 0.2 mm.;  $M$ , 45 kg.;  $L$ , 1.030 meters.

(4) East component:  $V$ , 8.3;  $e$ , 1.51;  $r$ , 0.0;  $M$ , 45 kg.;  $L$ , 1.030 meters.

	FIRST PRELIMINARY TREMORS.	SECOND PRELIMINARY TREMORS.	REGULAR WAVES.	PRINCIPAL PART.	MAX.	AMPLITUDE.
	<i>mm.</i>	<i>min.</i>	<i>min.</i>	<i>min.</i>	<i>min.</i>	<i>mm.</i>
(1) East component	23.7	...	...	...	58.2	17 +
(2) East component	24.1	34.2	49.7	...	57.1	16
(3) North component	25.0	...	51.4	56.6	58.0 to 01.5	70 +
(4) East component	...	...	50.7	...	54	17 +
Average . . .	<i>m.</i> 8. 24 16	<i>m.</i> <i>a.</i> 34 12	<i>m.</i> <i>a.</i> 50 36			
Interval . . .	11 48	21 44	38 08			

Duration (1) 4.4 hours; (2) 4.8 hours. The large amplitudes are probably due to coincidence of periods; they occur at different times for the different pendulums.

#### OSAKA, JAPAN.

Meteorological Observatory. N. Shimono, director.

Lat. 34° 42' N.; long. 135° 31' E.; distance, 77.30° or 8,594 km.; chord, 7,957 km.; direction, N. 56° W.

Seismograms, sheet No. 15.

The instrument used was an Omori horizontal pendulum, east component; mechanical registration on smoked paper.  $T_0$ , 27 seconds;  $V$ , 20;  $J$ , 3,600 meters.

	(a) FIRST PRELIMINARY TREMORS.	(6) SECOND PRELIMINARY TREMORS.	(d) REGULAR WAVES.	MAX.	AMPLITUDE	PERIOD.
	<i>m.</i> <i>a.</i>	<i>m.</i> <i>s.</i>	<i>m.</i> «.	<i>m.</i> <i>a.</i>	<i>mm.</i>	<i>sec.</i>
East component .	24 24	34 13	47 56 j	50 19	44	25
Interval . . .	11 56	21 45	35 28	50 03	31	

Duration, 3.1 hours. The period during the strong motion is closely that of the pendulum and in the absence of strong damping and exact knowledge of the damping ratio, the movement of the earth can not be estimated. The letters on the seismogram refer to the following times: *a*, 13<sup>h</sup> 24<sup>m</sup> 24<sup>s</sup>; *b*, 34<sup>m</sup> 13<sup>s</sup>; *c*, 42<sup>ra</sup> 26<sup>s</sup>; *d*, 47<sup>m</sup> 56<sup>s</sup>; *e*, 53<sup>m</sup> 51<sup>s</sup>; *f*, 14<sup>h</sup> 10<sup>m</sup> 22<sup>s</sup>; *g*, 25<sup>m</sup> 43<sup>s</sup>; *h*, 15<sup>h</sup> 01<sup>m</sup> 46<sup>s</sup>; *i*, 40<sup>m</sup> 11<sup>s</sup>; *j*, 16<sup>h</sup> 33<sup>m</sup> 08<sup>s</sup>.

## KOBE, JAPAN.

Meteorological Observatory. C. Nakagawa, director.

Lat. 34° 41' N.; long. 136° 10' E.; altitude, 53.3 meters; distance, 77.54° or 8,619 km.; chord, 7,976 km.; direction, N. 55° W.

Foundation, Paleozoic rocks.

Seismograms, sheet No. 5.

The instrument used was an Omori horizontal pendulum, north component; mechanical registration on smoked paper.  $T_0$ , 35 seconds;  $V$ , 10;  $L$ , 3,000 meters;  $M$ , 5 kg.;  $L$ , 75 cm.

	(a) FIRST PRELIMINARY TREMORS.	(b) SECOND PRELIMINARY TREMORS.	REGULAR WAVES.	MAX.	AMPLITUDE.	PERIOD.
North component . . .	<i>m.</i> 8. 24 23	<i>m.</i> <i>a.</i> 34 19	<i>m.</i> <i>s.</i> 50 20	<i>m.</i> <i>a.</i> 52 56	<i>mm.</i> 15	<i>sec.</i> 23
Interval . . .	11 55	21 51	37 52			

Duration, 3 hours. Altho the long waves appear quite definitely to begin at (c), the time seems somewhat late. There are two well-marked but separated waves in this part of the motion with a period of 31 seconds and a very large amplitude, possibly in part due to harmony of periods. The amplitude of the earth during the principal part can not be determined as the motion lasted only a short time and the damping is small.

The letters on the seismogram refer to the following times: *a*, 13<sup>h</sup> 24<sup>m</sup> 23<sup>s</sup>; *b*, 34<sup>m</sup> 19<sup>s</sup>; *c*, 45<sup>m</sup> 31<sup>s</sup>; *d*, 53<sup>m</sup> 39<sup>s</sup>; *e*, 59<sup>m</sup> 55<sup>s</sup>; *f*, 14<sup>h</sup> 06<sup>m</sup> 06<sup>s</sup>; *g*, 12<sup>m</sup> 32<sup>s</sup>; *h*, 22<sup>m</sup> 29<sup>s</sup>; *i*, 57<sup>m</sup> 35<sup>s</sup>; *j*, 16<sup>h</sup> 26<sup>m</sup> 13<sup>s</sup>.

## KEW, ENGLAND.

National Physical Laboratory. Dr. Charles Chree, in charge of seismograph.

Lat. 51° 28' N.; long. 0° 19' W.; altitude, 6 meters; distance, 77.63° or 8,630 km.; chord, 7,986 km.; direction, N. 32° E.

Foundation, deep alluvial gravel; Mesozoic limestone 1,150 feet below the surface.

Seismograms, sheet No. 1.

The instrument used was a Milne horizontal pendulum, east component; photographic registration.  $T_0$ , 18 to 19 seconds;  $V$ , 6.1;  $J$ , 520 meters;  $e$ , 1.114;  $r$ , 0.0 mm.; angular displacement, 1 mm. = 0.55";  $M$ , 255 gm.;  $L$ , 15.6 cm.

	FIRST PRELIMINARY TREMORS.	SECOND PRELIMINARY TREMORS.	REGULAR WAVES.	MAX.	AMPLITUDE
East component . . .	<i>min.</i> 25.7	<i>min.</i> 34.0	<i>min.</i> 50.0	<i>min.</i> 57.0 to 02.0	<i>mm.</i> 17+
Interval . . .	13.2	21.5	37.5		

Duration, 3.8 hours. The time of the first preliminary tremors has not been used in the determination of velocity of propagation; it is fully a minute later than at all other stations which do not differ considerably from Kew in distance from the focus; and the beginning of the movement on the seismogram is too indefinite to permit a satisfactory determination of its time.

**HAMBURG, GERMANY.**

Hauptstation für Erdbebenforschung. Dr. R. Schiitt, director.

Lat. 53° 34' N.; long. 9° 59' E.; altitude, 16.2 meters; distance, 79.74° or 8,866 km.;  
chord, 8,167 km.; direction, N. 26° E.

The instruments used were Rebeur-Paschwitz horizontal pendulums, modified by Dr. Hecker, two components; photographic registration.

	FIRST PRELIMINARY TREMORS.		SECOND PRELIMINARY TREMORS.		REGULAR WAVES.		PRINCIPAL PART.	
	<i>m.</i>	<i>s.</i>	<i>m.</i>	«	<i>m.</i>	«	<i>m.</i>	«
North component . . .	..	..	34	42	..	..	<b>51</b>	<b>57</b>
East component . . .	<b>24</b>	<b>32</b>	34	57	44	32	<b>51</b>	<b>34</b>
Average . . .	<b>24</b>	<b>32</b>	34	50	44	32	<b>51</b>	<b>45</b>
Interval . . .	<b>12</b>	<b>04</b>	22	22	32	04	<b>39</b>	<b>17</b>

**UCCLE, BELGIUM.**

Observatoire Royale de Belgique. M. G. Lecoite, director.

Lat. 50° 48' N.; long. 4° 22' E.; altitude, 100 meters; distance, 79.80° or 8,872 km.;  
chord, 8,173 km.; direction, N. 31° E.

Foundation, coarse Tertiary limestone.

Seismograms, sheet No. 2 a.

The instrument used was an Ehlert triple pendulum, photographic registration.

(1) N. 60° E. component:  $T_0$ , 11.25 seconds;  $J$ , 160;  $J$ , 5,100 meters;  $e$ , 1.003;  $r$ , 0.0 mm.;  $M$ , 185 gm.;  $L$ , 10.08 cm.

(2) N. 60° W. component:  $T_0$ , 10.53 seconds;  $J$ , 160;  $J$ , 4,400 meters;  $e$ , 1.004;  $r$ , 6.0 mm.;  $M$ , 185 gm.;  $L$ , 10.08 cm.

(3) North component:  $T_0$ , 11.15 seconds;  $J$ , 160;  $J$ , 5,100 meters;  $e$ , 1.004;  $r$ , 0.0 mm.;  $M$ , 185 gm.;  $L$ , 10.08 cm.

	FIRST PRELIMINARY TREMORS.		REGULAR WAVES.	
	<i>m.</i>	<i>s.</i>	<i>m.</i>	«
(1) N. 60° E. component . . .	24	27	34	57
(2) N. 60° W. component . . .	24	27	34	57
(3) North component . . .	24	27	34	57
Average . . .	24	27	34	57
Interval . . .	11	59	22	29

All three pendulums suffered permanent displacements during the disturbance.

**JURJEW, RUSSIA.**

Astronomical Observatory of the University. Prof. Dr. G. Lewitsky, director; Dr. A. Orloff, assistant.

Lat. 58° 23' N.; long. 26° 43' E.; altitude, 48.5 meters; distance, 80.27° or 8,924 km.; chord, 8,212 km.; direction, N. 16° E.

Foundation, fine sand.

Seismograms, sheet No. 10.

The instruments used were Zöllner-Repsold horizontal pendulums, two components; photographic registration.

(1) North component:  $T_0$ , 31.53 seconds;  $J$ , 64.5;  $J$ , 15,000 meters;  $e$ , 1.004;  $r$ , 0.0 mm.;  $M$ , 50 gm.;  $L$ , 13.3 cm.

(2) East component:  $T_0$ , 28.22 seconds; 7,64.9;  $J$ , 13,000 meters;  $e$ , 1.005;  $r$ , 0.0 mm.;  $M$ , 50 gm.;  $L$ , 13.3 cm.

	FIRST PRELIMINARY TREMORS.		SECOND PRELIMINARY TREMORS.	
	to.	8.	m.	a.
(1) North component . . .	24	45	34	43
(2) East component . . .	24	41	34	49
Average . . . . .	24	43	34	46
Interval . . . . .	12	15	22	18

The seismograms are carefully drawn from the original, parts of which were so faint, on account of the rapid movement, that they could not be reproduced. (The correction to G. M. T. should be +43 seconds and not —43 seconds, as marked on the seismograms.) The north component begins in the middle of the sheet at the bottom of the seismogram; it had an amplitude of 15 mm. when the sheet was put on. This movement gradually died down, but the pendulum was not perfectly still when the earthquake arrived 3<sup>h</sup> 10<sup>m</sup> later. The first preliminary tremors have a small amplitude, about 1 mm., and a period the same as the period of the pendulum, showing an extremely small disturbance. The second preliminary tremors have an increasing amplitude from about 10 mm. to 20 mm.; at 13<sup>h</sup> 50<sup>m</sup> 45<sup>s</sup> the motion becomes so large and the photographic record so faint that it can not be copied; a few turning points are shown in the lower part of the plate; this continues for the rest of this line. The record is again picked up at the beginning of the next line at about 14<sup>h</sup>. The center of the record is shown by the single line on the left of the plate. The movement gradually dies down, but still has an amplitude of 20 mm. two hours later. The east component begins in the middle of the sheet; it has small oscillations which entirely die out before the preliminary tremors arrive. The first preliminary tremors and second preliminary tremors begin at the same time as those of the north component, but they have larger amplitudes, the first attaining an amplitude of 7 mm.; and the second, beginning with nearly 50 mm., attain 120 mm. by 13<sup>h</sup> 48<sup>m</sup>, and a few minutes later (13<sup>h</sup> 53<sup>m</sup> 45<sup>s</sup>) are lost. They are picked up again 8 minutes later, and about 14<sup>h</sup> 25<sup>m</sup> drop to an amplitude of about 40 mm.; they then gradually die out more irregularly than the other component. The very large amplitudes are due to synchronism of the periods of the waves and the pendulums.

#### IRKUTSK, SIBERIA.

Meteorological and Magnetic Observatory. M. A. Voznesenskij, director.

Lat. 52° 16' N.; long. 57° 14' E.; altitude, 470 meters; distance, 80.82° or 8,986 km.; chord, 8,259 km.; direction, N. 27° W.

Foundation, hard Jurassic clay.

The instruments used were:

Repsold-Zöllner horizontal pendulums, two components; photographic registration. Seismograms, sheet No. 2 a.

(1) North component:  $T_0$  35 seconds;  $V$ , 57.5;  $J$ , 17,500 meters; angular displacement, 1 mm, = 0.011";  $M$ , 30 gm.;  $L$ , 14 cm.

(2) East component:  $T_0$  25.5 seconds;  $V$ , 57.5;  $J$ , 9,300 meters; angular displacement, 1 mm, = 0.021";  $M$ , 30 gm.;  $L$ , 14 cm.

Bosch-Omori horizontal pendulums, two components; mechanical registration on smoked paper. Seismograms, sheet No. 13.

(3) North and (4) East components:  $T_0$  24 seconds;  $V$ , 10 (?);  $J$ , 1,430 meters (?);  $M$ , 11kg. (?);  $L$ , 75 cm. (?).

(5) Milne horizontal pendulum, east component, photographic registration. Seismograms, sheet No. 2.  $T_o$ , 20.5 seconds;  $V$ , 6.1;  $\lambda$ , 700 meters;  $M$ , 255 gm.;  $L$ , 15.6 cm.

	FIRST PRELIMINARY TREMORS.	SECOND PRELIMINARY TREMORS.	REGULAR WAVES.	MAX.	AMPLITUDE.	PERIOD.
	<i>min.</i>	<i>min.</i>	<i>min.</i>	<i>min.</i>	<i>mm.</i>	<i>sec.</i>
(1) North component .	24.6	34.3	...	54.6	165	24
(2) East component .	24.7	34.4	...	58.7	87.6	
(3) North component .	24.7	35.0	...	02.7	4.0	
(4) East component .	24.6	34.5	...	01.0	6.0	
(5) East component .	24.4	34.3	51.3	05.3	17+	
Average . . . . .	<i>m.</i> 24 <i>s.</i> 36	<i>m.</i> 34 <i>s.</i> 50	51.3			
Interval . . . . .	12 08	22 22	38.8			

Duration, (1) and (2), 6.5 hours; (3) 2.5; (4) 2.7; (5) 4.6.

On the Zöllner-Repsold records there is no clear evidence of long waves. The strong motion seems to have been stronger and to have lasted longer on the east component; it also began nearly two minutes earlier; but the north component shows a marked movement between 16<sup>h</sup> and 18<sup>h</sup> which is lacking in the east movement.

It is interesting to compare the records from the similar instruments at Jurjew and Irkutsk, which are practically the same distance from the centrum. We find certain differences; at Jurjew the north component is apparently the stronger and holds its strong motion longer, but comes to rest sooner than the east component; after about 15<sup>h</sup> it seems to be dying down with very slight irregularities; whereas the east component experiences distinct disturbances up to 17<sup>h</sup> 30<sup>m</sup>. We could give almost the same description of the movement at Irkutsk if we interchanged components. This is curious, as the disturbance approaches the two stations in directions making about the same angle with the meridian. It is unfortunate that the instruments have so little damping that their proper motions persist for a long time and interfere with a better interpretation of the seismograms. For instance, it is impossible to say whether the prolonged strong motion of the north component at Jurjew is due to a continued strong disturbance or to the proper motion of the pendulum. The east component may have felt just as strong and long a disturbance but its large displacement may have been checked by it. We do not find this difference between the components of the strongly damped pendulum at Gottingen, which is but slightly further from the centrum.

The periods of the movement at Irkutsk are decidedly larger than at Jurjew; at the latter, during the first and second preliminary tremors the periods are about 30 seconds, very near the natural periods of the pendulums; at Irkutsk they are about 37 seconds and 50 seconds for the east and north components, respectively, in comparison with the natural periods of the pendulums of 25 and 35 seconds. During the large motion the east component did not record, and the north component is too irregular to determine a period, but both indicate comparatively large displacements of the ground.

The maximum displacements of the Bosch-Omori pendulums at Irkutsk seem entirely due to synchronism of periods and indicate a comparatively small earth amplitude, just the opposite of the indications of the Repsold-Zöllner pendulums. The beginning of the long waves is not apparent on the Zöllner instruments unless we take it at the beginning of the strong motion, but appears pretty well on the Bosch-Omori records, and the period is about 1 minute.

The times of arrival at Jurjew and Irkutsk are practically the same, indicating uniform velocities along the two paths followed.

## POTSDAM, GERMANY.

Kgl. Preussisches Geodätisches Institut. Prof. Dr. O. Hecker, in charge of seismographs.

Lat.  $52^{\circ} 53' N.$ ; long.  $13^{\circ} 04' E.$ ; altitude, 90 meters; distance,  $81.35^{\circ}$  or 9,042 km.; chord, 8,303 km.; direction, N.  $25^{\circ} E.$

Foundation, sand.

The instruments used were:

Rebeur-Paschwitz pendulums, photographic registration. Seismograms, sheet No. 4.

(1) North and (2) East components:  $T_o$ , 18 seconds;  $\gamma$ , 36;  $\lambda$ , 2,900 meters;  $e$ , 2.5;  $M$ , 70 gm.;  $L$ , 9 cm. (?).

Wiechert inverted pendulum, two components; mechanical registration on smoked paper. Seismograms, sheet No. 5.

(3) North component:  $T_o$ , 14 seconds;  $V$ , 133;  $J$ , 6,500 meters;  $e$ , 5;  $M$ , 1,000 kg.;  $U$ , 49 meters.

(4) East component;  $T_o$ , 14 seconds;  $V$ , 130;  $\lambda$ , 6,350 meters;  $e$ , 5;  $M$ , 1,000 kg.;  $L'$ , 49 meters.

	FIRST PRELIMINARY TREMORS.		SECOND PRELIMINARY TREMORS.	REGULAR WAVES.	PRINCIPAL PART.		MAX.	AMPLITUDE.	PERIOD.	
	<i>m.</i>	<i>s.</i>	min.	<i>min.</i>	<i>m.</i>	<i>a.</i>	<i>m.</i>	<i>a.</i>	<i>mm.</i>	<i>sec.</i>
(1) North component	24	50	35.6	52.3	..	..	..	..	..	..
(2) East component	..	..	..	52.0	..	..	..	..	60	23
(3) North component	24	50	35 27	51 18	54	50	56	40	85 +	28
(4) East component	24	51	35 05	51 40	54	50	56	07	80 +	28
Average . . .	24	50	35 23	51 49	54	50				
Interval . . .	12	22	22 55	39 21	42	22				

Duration, 6 hours.

On account of the overlapping of the records on the seismogram of the East component of the Rebeur-Paschwitz instrument the beginning of the first two phases can not be made out. There was a shifting of the median lines at about  $14^h$ , after which it exactly overlay the earlier line. The copyist has made the terminal part of the curve pass into the earlier part at about  $15^h 33^m$  ( $13^h 34^m$ ). The maximum amplitudes of the earth, as shown by the various instruments, approach the following values, tho the movements were not sufficiently regular to make the measures exact. (1) 1.7 mm.; (3) 2.7 mm.; (4) 2.2 mm. These maximums all occurred between  $13^h 50^m$  and  $13^h 57^m$ . The recording point passed its limits and ceased to record on (4) at the time when the amplitude was measured. (3) indicates an earth-amplitude of 3.65 mm. at  $13^h 53^m$ , during the long waves; the east component at that time is not sufficiently regular to yield a measure, but the total value must be greater than 4.

## GÖTTINGEN, GERMANY.

Geophysikalisches Institut der Universität. Prof. Dr. E. Wiechert, director.

Lat.  $51^{\circ} 33' N.$ ; long.  $9^{\circ} 58' E.$ ; altitude, 270 meters; distance,  $81.36^{\circ}$  or 9,0-10 km.; chord, 8,304 km.; direction, N.  $28^{\circ} E.$

Seismograms, sheet No. 12.

The instruments used, all having mechanical registration on smoked paper, were:

(1) Wiechert inverted pendulum, north component:  $T_m$  1.48 seconds;  $\lambda$ , 0.543 meter;  $V$ , 2,100;  $J$ , 1,140 meters;  $e$ , SA;  $r$ , 0.3 mm.;  $M$ , 17,000 kg.

Wiechert inverted pendulum, two components:

(2) North component:  $T_0$ , 14.07 seconds;  $V$ , 152;  $J$ , 7,500 meters;  $e$ , 3.9;  $r$ , 1.5 mm.;  $M$ , 1,200 kg.;  $I$ , 49 meters.

(3) East component:  $T_0$ , 12.6 seconds;  $J$ , 172;  $J$ , 6,700 meters;  $e$ , 3.4;  $r$ , 0.9 mm.;  $M$ , 1,200 kg.;  $I$ , 39.7 meters.

(4) Wiechert Vertical Motion Seismograph.  $T_0$ , 4.8 seconds;  $J$ , 170;  $J$ , 970 meters;  $e$ , 2.8;  $r$ , 0.1 mm.;  $M$ , 1,300 kg.;  $Z$ , 5.7 meters.

	FIRST PRELIMINARY TREMORS.		SECOND PRELIMINARY TREMORS.		REGULAR WAVES.		PRINCIPAL PART.			MAX.	AMPLITUDE.	PERIOD.
	<i>m.</i>	<i>s.</i>	<i>m.</i>	<i>s.</i>	<i>Tr.</i>	<i>s.</i>	<i>m.</i>	<i>s.</i>	<i>min.</i>			
(1) North component . . .	24	55	35	15	51	10	57	55 to 07.0	59	8.	18	20
(2) North component . . .	24	44	34	52	51	..	56	00 to 06.0	..	20	48+	17
(3) East component . . .	24	46	34	46	51	<i>ib</i>	55	54 to 10.0	..	..	40+	17
(4) Vertical component . . .	24	31	35	31	51	<i>ib</i>	..	..	05	..	15	16
Average . . . . .	24	44	35	06	51	05	56	36	15			
Interval . . . . .	12	16	22	38	38	37	44	08				

During the long waves, at 13<sup>h</sup> 54-54.5<sup>m</sup>, we find the following earth-amplitudes indicated: (1) North, 0.8mm.; (2) North, 0.97mm.; (3) East, 1.31 mm.; (4) Vertical, 1.64mm. at 13<sup>h</sup> 52-53<sup>m</sup>; probably the total would be about 2 mm. During the principal part: (1) North, 1.5 mm. at 13<sup>h</sup> 59<sup>m</sup> 20<sup>s</sup>; (2) North, 0.53 mm.; (3) East, 0.52 mm.; (4) Vertical, 0.7 mm., at 14<sup>h</sup> 06.5<sup>m</sup>. (2) and (3) give too small values for the pendulum struck against the stops during the large part of the principal part. It is to be noticed, however, that (1) gives a larger and (4) a smaller amplitude than during the long waves. Probably the maximum during the principal part was a little greater than 2 mm.

## COIMBRA, PORTUGAL.

Observatorio Magnetico-Meteorologico. Prof. A. S. Viegas, director.

Lat. 40° 12' N.; long. 8° 25' W.; altitude, 140.3 meters; distance, 81.39° or 9,049 km.; chord, 8,307 km.; direction, N. 45° E.

Foundation, Triassic sandstone.

Seismograms, sheet No. 1.

The instrument used was a Milne horizontal pendulum, east component; photographic registration;  $V$ , 6.1;  $M$ , 255 gm.

	FIRST PRELIMINARY TREMORS.	SECOND PRELIMINARY TREMORS.	REGULAR WAVES.	MAX.	AMPLITUDE.
East component . . .	<i>min.</i> 25.4	<i>min.</i> 35.0	<i>min.</i> 50.5	TO. «. 55 58	<i>mm.</i> 16
Interval . . . . .	12.9	22.5	38.0		

Duration, 3 hours. During the strong motion the period of the waves was about 24 seconds; the proper period of the pendulum is not known and the actual magnification can not be determined.

## LEIPZIG, GERMANY.

Kgl. Geologisches Bureau. Prof. Dr. Hermann Credner, director; Dr. F. Etwold, assistant.

Lat. 51° 20' N.; long. 12° 23.5' E.; distance, 82.40° or 9,161 km.; chord, 8,392 km.; direction, N. 26° E.

Foundation, alluvium and sands.

The instrument used was a Wiechert inverted pendulum, two components; mechanical registration on smoked paper.



(1) North component:  $T_0$ , 8.5 seconds; 7,220.6;  $J$ , 4,000 meters;  $\rho$ , 3.05;  $M$ , 1,100 kg.;  $U$ , 18.1 meters.

(2) East component:  $T_0$ , 8.5 seconds;  $V$ , 241;  $J$ , 4,350 meters;  $e$ , 2.4;  $M$ , 1,100 kg.;  $U$ , 18.1 meters.

	FIRST PRELIMINARY TREMORS.	SECOND PRELIMINARY TREMORS.	RECTOLAR WAVES.	PRINCIPAL PART.	MAX.	AMPLITUDE.	PERIOD.	EARTH'S AMPLITUDE.
(1) North component	<i>m. s.</i> 24 50	<i>m. s.</i> 35 39	<i>m. s.</i> 51 09	<i>min.</i> 56.0 to 06.3	<i>min.</i> 5 57.8 2 05.9	<i>mm.</i> 24 34	<i>sec.</i> 21 17	<i>mm.</i> 0.59 0.51
(2) East component	24 50	35 39	51 34	55.0 to 06.5	<i>m. s.</i> 5 55 41 5 57 28	64+ 64+	26 22	1.81+ 1.55+
Average . . .	24 50	35 39	51 21	<i>m. s.</i> 55 30				
Interval . . .	12 22	23 11	38 53	43 02				

Duration, 4.4 hours. At 13<sup>h</sup> 54<sup>m</sup> the long waves of north component had a period of about 40 seconds and an amplitude of 10 mm. This gives an amplitude on the north component of the earth-movement of about 1 mm.; at the same time the east component indicates an earth-amplitude of 1.2 mm., and the total may be 1.5 mm. At 13<sup>h</sup> 55<sup>m</sup> 41<sup>s</sup>, the east earth-amplitude is 1.81 mm. and the combined amplitude is 2.17 mm. At 13<sup>h</sup> 57.5<sup>m</sup> the north earth component is 0.58 and east component 1.55; total 1.65 mm. These amplitudes are not entirely trustworthy, because at times the instrument reached its limit and the motion was not very regular. At Plauen, a substation of Leipzig, and 90 km. to the south, the record resembled that at Leipzig.

The seismogram from Leipzig is reproduced in "Siebenter Bericht der Erdbebenstation Leipzig" (Ber. der Math. Phys. Kl. d. Kön. Sächsischen Gesells. d. Wissens. zu Leipzig. Bd. LIX, January 14, 1907). A copy of this was forwarded by Dr. Credner, but the seismogram was overlooked, and therefore is not reproduced in the atlas.

## JENA, GERMANY.

Stemwarte. Prof. Dr. Rudolph Straubel, director; Dr. Eppenstein, assistant.

Lat. 50°56'N.; long. 11°35'E.; altitude, 155 meters; distance, 82.45° or 9,167 km.; chord, 8,396 km.; direction, N. 27° E.

Foundation, in the valley of the Saale River, on 4 to 5 meters of weathered sandstone, underlain by the Bunt sandstone.

Seismograms, sheet No. 11.

The instrument used was a Wiechert inverted pendulum, two components; mechanical registration on smoked paper.

(1) North component:  $T_0$ , 11.6 seconds;  $V$ , 160;  $J$ , 5,300 meters;  $e$ , 5.0;  $M$ , 1,200 kg.;  $U$ , 33.6 meters.

(2) East component:  $T_0$ , 11.6 seconds;  $F$ , 180;  $J$ , 6,000;  $e$ , 5.0;  $M$ , 1,200 kg.;  $U$ , 33.6 meters.

	FIRST PRELIMINARY TREMORS.	SECOND PRELIMINARY TREMORS.	REGULAR WAVES.	PRINCIPAL PART.	MAX.	AMPLITUDE.
(1) North component	<i>m. a.</i> 24 34	<i>m. s.</i> 35 09	<i>min.</i> 51.2	<i>min.</i> 56.5 to 07.5	<i>min.</i> 55.0 to 59.0	<i>mm.</i> 80+
(2) East component	24 34	35 09	51.2	56.8	58.0 to 00.	80+
Average . . .	24 34	35 00	<i>m. e.</i> 51 12	56 39		
Interval . . .	12 06	22 41	38 44	44 11		

Duration, 5.6 hours. From 54 to 56<sup>m</sup>, during the long waves the earth's amplitudes were the largest, being 2.6 mm. for the north and 1.9 mm. for the east component, a possible total of 3.2 mm. At about 59<sup>m</sup> the indicated earth's amplitudes are 2.0 mm. and 1.5 mm. for north and east components, respectively, and with a possible total of 2.5 mm.; but this is undoubtedly too small, as the instruments reached the stops.

## STRASSBURG, GERMANY.

Kais. Hauptstation für Erdbebenforschung. Prof. Dr. G. Gerland, director; Dr. E. Rudolph, assistant.

Lat. 48° 35' N.; long. 7° 46' E.; altitude, 135 meters; distance, 82.91° or 9,218 km.; chord, 8,434 km.; direction, N. 30° E.

Foundation, compact alluvial gravel.

Seismograms, sheet No. 14.

The instruments used were:

Rebeur-Ehlertriple pendulums, No. 2, two components; photographic registration.<sup>1</sup>

(1) N. 30° E. component; (2) E. component;  $T_0$ , 10 seconds;  $V$ , 45;  $J$ , 1,120 meters.

(3) Omori horizontal pendulum, east component.

Vicentini microseismograph, three components; mechanical registration on smoked paper.

(4) North and (5) east components. (6) Vertical component;  $V$ , 85; no damping and very slight friction.

(7) Schmidt trifilar gravimeter.

	FIRST PRELIMINARY TREMORS.		SECOND PRELIMINARY TREMORS.		REGULAR WAVES.	PRINCIPAL PART.	MAX.		AMPLITUDE.	PERIOD.	EARTH'S AMPLITUDE.
	<i>in.</i>	<i>s.</i>	<i>m.</i>	<i>s.</i>	<i>min.</i>	<i>min.</i>	<i>m.</i>	<i>s.</i>	<i>mm.</i>	<i>sec.</i>	<i>mm.</i>
(1) N. 30° E. component	24	52	35	18	51.2?	58.0	02	39	16.5	16	0.59
(2) East component .	25	06	35	28	$\frac{m}{46}$ 13	.. .	01	19	7.0	20	0.47
(3) East component .	24	51	35	17	46 36	.. .	07	27	4.4	12	
(4) North component .	..	..	..	..	48	.. .	01	25	2.0	22	
(5) East component .	24	53	35	18	46 05	.. .	02	35	2.0	18	
(6) Vertical component .	25	12	..	..	52	.. .	05	20	0.3	14	
(7) Vertical component	24	43	..	..	50 31	.. .	02	31	1.3	16	
Average . . . . .	24	57	35	20							
Interval . . . . .	12	29	22	52							

Duration, Rebeur, 2.5 to 3.5 hours; Omori, Vicentini, Schmidt, 1 to 2 hours. The possible maximum earth-amplitude is about 0.75 mm., according to the record of the Rebeur-Ehlertriple instrument.

The times, amplitudes, and periods are taken from the "Wöchentliches Erdbebenbericht der Kais. Hauptstation für Erdbebenforschung zur Strassburg," with the exception of the long waves, principal part and maximum of (1), which were obtained from the seismogram. It is evident that the various times under regular waves do not refer to the same phase.

## MOSCOW, RUSSIA.

Imperial University. Dr. Ernest Leyst, in charge of seismographs.

Lat. 55° 45' N.; long. 37° 34' E.; distance, 84.72° or 9,419 km.; chord, 8,584 km.; direction, N. 11° E.

Foundation, sand.

<sup>1</sup> The constants of these instruments are taken from the text accompanying "Seismogramme de nordpazifischen und sudamerikanischen Erdbebens am 16 August, 1906," a publication of the International Seismological Association. They probably also apply to April 18, 1906.

The instruments used were Bosch-Omori horizontal pendulums, two components; mechanical registration on smoked paper.

(1) North and (2) east components:  $T_0$ , 60 seconds;  $M$ , 10 kg.;  $L$ , 75 cm.<sup>1</sup>

	ITRBT PRELIMINARY TREMORS.	PRINCIPAL PART.	MAX.	AMPLITUDE.
(1) North component .	<i>min.</i> 28	<i>min.</i> 57 to 12	<i>min.</i> 59 to 01	<i>mm.</i> 150+ <sup>2</sup>
(2) East component .	51	54 to 04	57 to 03	150+ <sup>3</sup>

## MUNICH, GERMANY,

Kgl. Observatorium für Erdmagnetismus und Erdbebenstation. Dr. J. B. Messerschmitt, director.

Lat. 48° 09' N.; long. 11° 36.5' E.; altitude, 530 meters; distance, 84.75° or 9,423 km.; chord, 8,587 km.; direction, N. 29° E.

Seismograms, sheet No. 5.

The instrument used was a Wiechert inverted pendulum.

(1) North and (2) east components:  $T_0$ , 12.1 seconds;  $V$ , 200;  $J$ , 7,300 meters;  $e$ , 6.0;  $M$ , 1,000 kg.;  $U$ , 36.6 meters.

	FIRST PRELIMINARY TREMORS.	SECOND PRELIMINARY TREMORS.	REGULAR WAVES.	MAX.	AMPLITUDE.	PERIOD.	EARTH'S AMPLITUDE.
(1) North component	<i>m.</i> 25	<i>m.</i> 35	<i>TO.</i> 52	<i>min.</i> 04	<i>mm.</i> 80 +	<i>sec.</i> ?	<i>mm.</i> 0.8 +
(2) East component	<i>s.</i> 00	<i>a.</i> 26	<i>«.</i> 00	58	80 +	20	
Average . . .	25	35	51				
Interval . . .	00	34	43				
	12	06	15				

At 13<sup>h</sup> 52<sup>m</sup> the north component of the earth's movement is 0.47 mm., and the east component 1.26; a possible total of 1.35 mm.; this is during the long waves. During the principal part at 13<sup>h</sup> 58<sup>m</sup>, the east indicator went beyond the limits, indicating an earth-amplitude of more than 1.25 mm.; at the same time the north indicator showed an earth-amplitude of 0.77 mm.; that is, the total amplitude was possibly greater than 1.47 mm. At 14<sup>h</sup> 05<sup>m</sup> the north indicator exceeded the limits; and after that time no further record was made.

It is possible that the regular waves should be put about 4 minutes earlier; but the phase here taken is evidently the same as that taken for the regular waves at Jena.

## SAN FERNANDO, SPAIN.

Institute y Observatorio de Marina. Capitan Thomas de Azcarate, director.

Lat. 36° 28' N.; long. 6° 12' W.; altitude, 28 meters; distance, 85.25° or 9,478 km.; chord, 8,628 km.; direction, N. 46° E.

Foundation, solid rock.

Seismograms, sheet No. 1.

The instrument used was a Milne horizontal pendulum, east component; photographic registration;  $T_0$ , 20 seconds;  $F$ , 0.1;  $J$ , 600 meters;  $e$ , 1.13;  $3f$ , 255 gm.;  $l$ , 15.6 cm.

<sup>1</sup> The times at Moscow are taken from an article by Or, E. Leyst in the Bulletin of the Naturalists of Moscow, Nos. 1 and 2, 1900. They are given to minutes only. It is evident that the beginning was not recorded, and the identification of the phases actually recorded is uncertain.

\*Off paper.

	FIRST PRELIMINARY TRBMOES.	SECOND PRELIMINARY TRBMOES.	REGULAR WAVES.	MAX.	AMPLITUDE.
East component . . .	25.1	35.3	48.5 or 53.7	57.9 104.2	17.5 + 17.5 +
Interval . . . . .	12.6	22.8	36.0 or 41.5		

The identification of the beginning of the regular waves is very doubtful.

TORTOSA, SPAIN.

Observatorio del Ebro. P. R. Cirera, S. J., director.

Lat. 40° 49' N.; long. 0° 30' E.; altitude, 38 meters; distance, 85.65° or 9,522 km.;  
chord, 8,660 km.; direction, N. 39° E.

Foundation, solid rock; cretaceous strata.

The instrument used was a Vicentini microseismograph, two horizontal components; mechanical registration on smoked paper.  $T_0$ , 1.8 seconds;  $J$ , 180;  $J$ , 1,450 meters;  $iW$ , 100 kg.;  $L$ , 1.43 meters.

	FIRST PRELIMINARY TREMORS.	SECOND PRELIMINARY TREMORS.	REGULAR WAVES.	MAX.	AMPLITUDE.	PERIOD.	EARTH'S AMPLITUDE.
Average . . . . .	<i>m. a.</i> 24 55	<i>m. a.</i> 36 00	<i>m. a.</i> 55 00	18.0	3	16.4	1.36
Interval . . . . .	12 27	23 32	42 32				

Duration, 2.5 hours. If both components have the same maximum amplitude at the same time, the total earth-amplitude might be 1.82 mm.

KREMSMÜNSTER, AUSTRIA.

Observatoire des Benedictines. P. Franz Schwab, director.

Lat. 48° 03' N.; long. 14° 08' E.; altitude, 380 meters; distance, 85.77° or 9,535 km.;  
chord, 8,670 km.; direction, N. 27° E.

Foundation, about 20 meters of glacial till lying on Tertiary strata.

Seismograms, sheet No. 2.<sup>1</sup>

The instruments used were Ehlert horizontal pendulums (triple); photographic registration.

(1) N. 13° W. component:  $T_0$ , 10seconds;  $J$ , 81.4;  $J$ , 2,000 meters;  $e$ , 1.0;  $L$ , 10 cm.

(2) N. 47° E. component:  $JP_0$ , 10seconds;  $J$ , 76.7;  $J$ , 1,900meters;  $e$ , 1.0;  $L$ , 10cm.

(3) N. 73° W. component:  $T_0$ , 10 seconds;  $J$ , 81.4;  $J$ , 2,000meters;  $e$ , 1.0;  $L$ , 10 cm.

	FIRST PRELIMINARY TREMORS.	SECOND PRELIMINARY TREMORS.	PRINCIPAL PART.	MAX.	AMPLITUDE.
(1) N. 13° W. component.	24.4	38.3?	01.9?	37.5 106.8 139.1	13 18 23
(2) N. 47° E. component .	24.4	35.5	49.1?	01.6 105.8 140.8	31 26 10
(3) N. 73° W. component,	24.4	...	....	00.2 (05.8)	15 17
Average . . . . .	24.4	35.5			
Interval . . . . .	11.9	23.0			

<sup>1</sup> The middle record of the seismogram records the N. 47° E. component of the motion and not the N. 47° W. component as indicated.

Duration, 1.8 hours. The three Ehlert pendulums give very different effects. They all begin at closely the same time but the second group is well shown only on (2), the instrument which records the northeast movement, that is, at right angles to the direction of propagation; this indicates a transverse wave. It can be recognized on (1), recording the north-northwest component, at 38.3<sup>m</sup>, but not so clearly. The beginning of the regular waves is not recognizable; nor can we be sure of the time of beginning of the principal part.

The lines just below the seismograms are the records of a different hour.

#### KRAKAU, AUSTRIA.

K. K. Sternwarte, Prof. Dr. M. F. Rudski, director.

Lat. 50° 04' N.; long. 19° 58' E.; altitude, 205 meters; distance, 85.98° or 9,558 km.; chord, 8,687 km.; direction, N. 23° E.

Foundation, compact sandy clay alluvium.

Seismograms, sheet No. 13.

The instruments used were Bosch-Omori horizontal pendulums, two components; mechanical registration on smoked paper.

(1) Northwest component:  $T_0$ , 31.2 seconds;  $V$ , 10;  $\lambda$ , 2,400 meters;  $e$ , 1.0 (?);  $r$ , 2.8 mm. (?);  $M$ , 11 kg.;  $L$ , 75 cm.

(2) Northeast component:  $T_0$ , 25.8 seconds;  $V$ , 9.6;  $J$ , 1,600 meters;  $e$ , 1.24 (?);  $r$ , 2.1 mm. (?);  $M$ , 11 kg.;  $L$ , 75 cm.

	SECOND PRELIMINARY TREMORS.	REGULAR WAVES.	PRINCIPAL PART.	MAX.	AMPLI- TITUDE.	PERIOD.
	<i>mfn.</i>	<i>win.</i>	<i>min.</i>	<i>mfn.</i>	<i>mm.</i>	<i>sec</i>
(1) Northwest component	35.8	54.5	57.1	00.9	20	32
(2) Northeast component	35.6	53.6	58.0	59.2	55	24
Average	<i>m.</i> «. 35 42	<i>m.</i> <i>a.</i> 54 06	<i>m.</i> ». 57 33?			
Interval	23 14	41 38	45 07?			

Duration, northwest, 2.3 hours; northeast, 1.8 hours.

The beginning of the disturbance was not registered, tho very slight movements can be made out on the northwest component about 13<sup>h</sup> 27<sup>m</sup>; they are very slight and would not be recognized unless especially lookt for. The early motion (second preliminary tremors) is somewhat larger in the northwest than in the northeast component, indicating longitudinal waves; but this may be due to friction in the latter component. It is not entirely clear why the first preliminary tremors were not properly registered; the seismograms show that the northeast component had strong, solid friction which would be sufficient to prevent it from registering very small disturbances; but this condition is not so evident in the northwest component.

Dr. Rudski only gives the times to tenths of minutes on account of the uncertainty of the beginning of the different phases; but the clock-time is perfect. The periods during the strong motion are so close to the natural periods of the pendulum that we can not make a good determination of the earth's movement. The values of the damping ratios and the solid friction are determined from observations made long before the date of the earthquake.

#### GRANADA, SPAIN.

Observatorio de Cartuja. P. S. Navarro-Neumann, S. J., director.

Lat. 37° 11' N.; long. 3° 48' W.; altitude, 776 meters; distance, 86.08° or 9,570 km.; chord, 8,696 km.; direction, N. 44° E.

Foundation, piers are directly on Tertiary limestone.

Seismograms, sheet No. 14.

The instruments used were:

(1) Stiattesi horizontal pendulum, east component; mechanical registration on smoked paper.  $T_0$ , 17.6 seconds;  $V$ , 25;  $\lambda$ , 1,900 meters;  $M$ , 208 kg.;  $L$ , 1.75 meters.

(2) Vicentini microseismograph, east component; mechanical registration on smoked paper.  $T_0$ , 3.4 seconds;  $V$ , 155;  $\lambda$ , 450 meters;  $M$ , 312 kg.;  $L$ , 2.88 meters.

	FIRST PRELIMINARY TREMORS.	SECOND PRELIMINARY TREMORS.	REGULAR WAVES.	PRINCIPAL PART.	MAX.	AMPLITUDE.	PERIOD.	EARTH'S AMPLITUDE.
	<i>m. a.</i>	<i>m. «.</i>	<i>m. «.</i>	<i>min.</i>	<i>min.</i>	<i>mm.</i>	<i>sec.</i>	<i>mm.</i>
(1) East component	24 40	35 20	48 09	54.6 to 11.0	(58.0 ^05.8 (08.5	46 + ... ...	17.6 ... ...	... ... ...
(2) East component	24 40	35 20	** **	54.7 to 11.0	(55.2 ^57.2	28.1 16.7	4.2 4.0	1.8 0.6
Average Interval . . . .	24 40 12 12	35 20 22 52	48 09 35 31	<i>m. a.</i> 54 39 42 11				

Duration, 5.5 hours. The time of the regular waves is taken a little later than the time marked on the seismogram; it is evident that what is here taken for the beginning of the principal part is that of the regular waves on the Krakau, the Pavia, and the Vienna seismograms; it is accordingly so considered in the determination of velocity of propagation.

#### PAVIA, ITALY.

R. Osservatorio Geofisico. Dr. P. Gamba, director.

Lat.  $45^{\circ} 11' N.$ ; long.  $9^{\circ} 10' E.$ ; altitude, 81.7 meters; distance,  $86.20^{\circ}$  or 9,583 km.; chord, 8,707 km.; direction, N.  $32^{\circ} E.$

Foundation, Quarternary alluvium, about 200 meters thick.

Seismograms, sheet No. 7.

The instrument used was an Agamennone vertical pendulum, two horizontal components; mechanical registration with ink on paper.

(1) Northeast component:  $T_0$ , 6 seconds;  $V$ , 20;  $\lambda$ , 180 meters;  $e$ , 1.14;  $r$ , 0.38 mm.;  $M$ , 200 kg.;  $L$ , 8.96 meters.

(2) Southeast component:  $T_0$ , 6 seconds;  $V$ , 20;  $\lambda$ , 180 meters;  $e$ , 1.52;  $r$ , 1.05 mm.;  $M$ , 200 kg.;  $L$ , 8.96 meters.

	FIRST PRELIMINARY TREMORS.	SECOND PRELIMINARY TREMORS.	REGULAR WAVES.	PRINCIPAL PART.	MAX.	AMPLITUDE.	PERIOD.	EARTH'S AMPLITUDE.
	<i>m. a.</i>	<i>m. e.</i>	<i>m. s.</i>	<i>m. a. TO «.</i>	<i>m. ».</i>	<i>mm.</i>	<i>sec.</i>	<i>mm.</i>
(1) Northeast component	25 06	35 06	54 00	59 20 to 08 40	04 25	8.0	15	4.0
(2) Southeast component	24 46	.. ..	.. ..	02 30 to 08 30	f 03 15 106 25	10.0 9.5	16.0 13.8	5.0 3.0
Average Interval . . . .	24 56 12 28	35 06 22 38	54 00 41 32	00 55? 48 27?				

Duration, 2+ hours. The second group begins more sharply in the northeast than in the northwest component, *i.e.*, at right angles to the direction of propagation. The long waves are also better marked on this component and the principal part begins earlier and lasts longer, tho it has a slightly greater maximum on the other component. This is probably not a question of period, as both components have the same; but the less well-defined record of the southeast component is probably in part due to the greater friction; its value of  $r$  is more than twice that of the other component.

The period of the regular waves on the northeast component at 13<sup>h</sup> 56<sup>m</sup> is about 27 seconds; and amplitude 2.8 mm.; indicating an earth-amplitude of 2.7 mm. An earth-amplitude of 2.2 mm. is the maximum on the northeast component at 14<sup>h</sup> 04.4<sup>m</sup>; both of these maxima occur at times of minima on the northwest component. An earth-amplitude of 3 mm. is shown on the southeast component at 14<sup>h</sup> 03<sup>m</sup>; at this time the earth-amplitude on the northeast component is only about 1 mm., so that the total amplitude may be 3.3 mm.

## VIENNA, AUSTRIA.

K. K. Zentralanstalt für Meteorologie und Geodynamik. Prof. Dr. J. M. Pernter, director.

Lat. 48° 15' N.; long. 16° 21.5' E.; altitude, 200 meters; distance, 86.37° or 9,602 km.; chord, 8,719 km.; direction, N. 26° E.

Foundation, loam soil.

Seismograms, sheet No. 9.

The instrument used was a Wiechert inverted pendulum, two components; mechanical registration on smoked paper.

(1) North and (2) east components:  $T_0$ , 14 seconds;  $V$ , 250;  $J$ , 12,500 meters;  $\ll$ , 2.0;  $M$ , 1,000 kg.;  $U$ , 49 meters.

	FIRST PRELIMINARY TREMORS.		SECOND PRELIMINARY TREMORS.		REGULAR WAVES.		PRINCIPAL PART.		MAX.	AMPLITUDE.	PERIOD.	EARTH'S AMPLITUDE.	
	<i>m.</i>	<i>s.</i>	<i>m.</i>	<i>s.</i>	<i>m.</i>	<i>a.</i>	<i>min.</i>						
(1) North component . . . . .	<b>25</b>	<b>15</b>	36	08	53	58	58.0 to 11.5		<b>08</b>	<b>00</b>	<b>35</b>	18.8	0.11
(2) East component . . . . .	<b>25</b>	<b>15</b>	36	09	53	24	57.1		<b>59</b>	<b>35</b>	<b>30</b>	23.4	0.23
Average . . . . .	<b>25</b>	<b>15</b>	36	08	53	<b>41</b>	<i>m.</i>	<i>s.</i>					
Interval . . . . .	<b>12</b>	<b>47</b>	23	40	<b>41</b>	13	57	33					
							45	05					

Duration, 2.7 hours. The times of arrival of the regular waves is difficult to determine; it is possible, but not probable, that they should be taken about 6 minutes later. Tho the second group are also slightly questionable, the time given is probably correct. The earth-amplitude was slightly larger for the east component; it was 0.21 mm. at 13<sup>h</sup> 59.5<sup>m</sup> against 0.09 mm. for the north component; it was 0.14 mm. at 14<sup>h</sup> 04.5<sup>m</sup>, 14<sup>h</sup> 06.5<sup>m</sup>, and 14<sup>h</sup> 08<sup>fa</sup>; and for the north component it was 0.19 mm. at 13<sup>h</sup> 58.5<sup>m</sup> and 0.13 mm. at 14<sup>h</sup> 08<sup>m</sup>.

## SAL6 (BRESCIA), ITALY.

Osservatorio Geodinamico. Signor P. Bettoni, director.

Lat. 45° 36' N.; long. 10° 30' E.; distance, 86.42° or 9,608 km.; chord, 8,722 km.; direction, N. 31° E.

The instrument used was an Agamermone seismometrograph, northeast and northwest components; mechanical registration with ink on white paper.  $T_0$ , 7.8 seconds;  $V$ , 10;  $J$ , 150 meters;  $M$ , 220 kg.

A very faint movement is discernible at 13<sup>h</sup> 52<sup>m</sup>, which reaches a maximum of 2 mm. amplitude at 14<sup>h</sup> 05<sup>m</sup> on the northeast component. The greatest amplitude on the northwest component is only 0.2 mm. The transverse waves are therefore much stronger than the longitudinal. Earth-amplitudes can not be determined. The seismogram arrived too late for insertion in the atlas.

## LATBACH, AUSTRIA.

Erdbebenwarte. Prof. Dr. A. Belar, director.

Lat. 46° 03' N.; long. 14° 31' E.; distance, 87.22° or 9,697 km.; chord, 8,786 km.; direction, N. 29° E.

The instruments used were:

Ehlertriple pendulums, three components; photographic registration.

(1) North component:  $T_0$ , 3 seconds.(2) East component;  $T_0$ , 7 seconds.(3) Northeast component:  $T_0$ , 12 seconds.

Horizontal pendulum, two components.

(4) Northeast and (5) northwest components: this instrument consists of a box containing 40 kg. of stone pressing against a steel point and supported by a long wire; registration with ink on white paper;  $T_0$ , 20 seconds;  $V$ , 11;  $M$ , 40 kg.

Vicentini microseismograph; registration on smoked paper.

(6) North, (7) east, and (8) vertical components; 7,100.

Seismograph (construction not known).

(9) North and (10) east components;  $V$ , 12.6.

	FIRST PRELIMINARY TREMORS.		SECOND PRELIMINARY TREMORS.		PRINCIPAL PART.				MAX.		AMPLITUDE.	PERIOD.
	<i>m.</i>	<i>a.</i>	<i>m.</i>	<i>a.</i>	<i>m.</i>	<i>a.</i>	<i>m.</i>	<i>a.</i>	<i>m.</i>	<i>a.</i>	<i>mm.</i>	<i>sec.</i>
(1) North component . . .	25	25	35	38	..	..	..	..	..	..	.	..
(2) East component . . .	25	37	35	30	54	21 to 11	08	59	47	25*	.	..
(3) Northeast component . . .	25	30	35	21	54	10 to 10	00	59	52	30	.	..
(4) Northeast component <sup>1</sup> . . .	26	52	36	47	52	17 to 11	20	02	42	5.5	.	23
(5) Northwest component <sup>1</sup> . . .	26	31	36	25	52	38 to 11	32	02	52	6	.	..
(6) North component . . .	25	36	35	31	53	56 to 11	03	59	55	3.7	.	..
(7) East component . . .	25	34	35	29	54	09 to 10	57	59	52	3.0	.	..
(8) Vertical component . . .	25	37	35	32	54	15 to 12	00	00	02	1.0	.	..
(9) North component . . .	25	37	..	..	..	..	..	..	..	..	.	..
(10) East component . . .	25	38	..	..	..	..	..	..	..	..	.	..
Average . . . . .	25	34	35	30	54	10						
Interval . . . . .	13	06	23	02	41	42						

## TRIEST, AUSTRIA.

K. K. Maritimes Observatorium. Prof. Dr. Edu. Mazelle, director.

Lat. 45° 34' N.; long. 13° 46' E.; altitude, 67.5 meters; distance, 87.74° or 9,754 km.; chord, 8,828 km.; direction, N. 29° E.

Foundation, rock.

The instruments used were:

Ehlertriple pendulums (triple); photographic registration.

(1) North component:  $T_0$ , 12 seconds;  $V$ , 88;  $J$ , 3,150 meters;  $U$ , 35.8 meters;  $M$ , 200(?)gm.;  $L$ , 9.9 cm.(2) N. 60° W. component:  $T_0$ , 14 seconds;  $V$ , 84;  $J$ , 4,100 meters;  $M$ , 200 (?) gm.;  $L$ , 9.9 cm.(3) N. 60° E. component:  $T_0$ , 18 seconds;  $V$ , 88;  $J$ , 7,100 meters;  $U$ , 80.7 meters;  $M$ , 200(?)gm.;  $L$ , 9.9 cm.

Vicentini microseismograph, three components; mechanical registration on smoked paper.

(4) North and (5) east components:  $T_0$ , 2.41 seconds;  $V$ , 100;  $J$ , 143 meters;  $M$ , 100 kg.;  $L$ , 1.13 meters.<sup>1</sup> The records of this instrument were not used in making up the average, as they differ so materially from the others.



(6) Vertical component:  $T_0$ , 0.95 seconds;  $V$ , 100;  $J$ , 22.5 meters;  $M$ , 45 kg.;  $L$ , 1.50 meters.

	FIRST PRELIMINARY TREMORS.		SECOND PRELIMINARY TREMORS.		REGULAR WAVES.	MAX.	AMPLITUDE.	PERIOD.	
	m.	sec.	m.	sec.	m.	a.	min.	sec.	
(1) North component . . .	24	33	35	03	..	..	04.6	22	...
(2) N. 60° W. component . . .	25	28	35	34	..	..	05.8	40	...
(3) N. 60° E. component . . .	25	11	35	18	..	..	05.4	28	...
(4) North component . . .	25	26	35	47	45	30	05.7	2.0	18"
(5) East component . . .	..	..	36	18	49	31	03.0	1.5	18.9
(6) Vertical component . . .	..	..	..	..	..	..	05.7	0.5	17.5
Average . . . . .	25	09	35	36					
Interval . . . . .	12	41	23	08					

Duration, Ehlert, 3 hours; Vicentini, 2 hours. The movement on the vertical component began at 02<sup>m</sup> 51<sup>s</sup> with reinforcement at 05<sup>m</sup> 18<sup>s</sup>. The seismograms of the Vicentini instrument were too faint to reproduce, but we can determine from them the movements of the earth. At 14<sup>h</sup> 05.7<sup>m</sup> the earth's amplitude was: North, 1.1 mm.; east, 0.1 mm.; vertical, 0.9; total, 1.4 mm. At 14<sup>h</sup> 03<sup>m</sup>: North, 1.03; east, 0.9; vertical, 0; total, 1.4 mm. These amplitudes should be a little larger, as the seismograms from which they were determined were slightly reduced.

## BUDAPEST, HUNGARY.

Seismological Observatory of the University. Prof. Dr. R. de Kovesligethy, director. Lat. 47° 29.5' N.; long. 19° 04' W.; altitude, 110 meters; distance, 87.93° or 9,777 km.; chord, 8,846 km.; direction, N. 25° E.

Foundation, alluvium on Tertiary strata.

The instruments used were:

Bosch-Omori horizontal pendulum, north component:  $T_0$ , 23 seconds;  $V$ , 7, 9;  $J$ , 1,190 meters;  $M$ , 10 kg.;  $L$ , 75 cm.

Vicentini-Konkoly vertical pendulum.

North component:  $T_0$ , 2.45 seconds;  $V$ , 7, 44;  $J$ , 66 meters;  $M$ , 105 kg.;  $L$ , 1.5 meters.

East component:  $T_0$ , 2.45 seconds;  $V$ , 60;  $J$ , 90 meters;  $M$ , 105 kg.;  $L$ , 1.5 meters.

The clock controlling the time marks was not working, so that no time records were made; but the "Bulletin hebdomadaire des observatoires sismiques de la Hongrie et de la Croatie" gives the maximum amplitudes and the corresponding periods of the waves, which enables us to calculate the earth-amplitudes when the instruments recorded a maximum. We have:

Bosch-Omori, north component: amplitude, 22.3 mm.; period, 15 seconds; earth's amplitude, 1.42 mm.

Vicentini-Konkoly, north component: amplitude, 1.0 mm.; period, 26 seconds; earth's amplitude, 2.5 mm.

Vicentini-Konkoly, east component: amplitude, 0.55 mm.; period, 26 seconds; earth's amplitude, 1.06 mm.

## O'GYALLA, HUNGARY.

Seismological, Meteorological, and Geodynamic Observatory. Dr. N. Thege von Konkoly, director.

Lat. 47° 52' N.; long. 18° 12' E.; altitude, 111 meters; distance, 88.08° or 9,792 km.; chord, 8,856 km.; direction, N. 25° E.

Foundation, on a sandy plain.

The instruments used were:

Bosch-Omori horizontal pendulums, two components; mechanical registration on smoked paper.

(1) North component:  $T_0$ , 23 seconds;  $V$ , 10;  $J$ , 1,300 meters;  $e$ , 1.17;  $M$ , 11 kg.;  $L$ , 75 cm.

(2) East component:  $T_0$ , 21 seconds;  $V$ , 10;  $J$ , 1,050 meters;  $e$ , 1.17;  $M$ , 11 kg.;  $L$ , 75 cm.

Vicentini-Konkoly vertical pendulum, two components; mechanical registration on smoked paper.

(3) North component:  $T_0$ , 2.5 seconds;  $V$ , 41;  $J$ , 64 meters;  $e$ , 1.105;  $M$ , 105 kg.;  $L$ , 1.55 meters.

(4) East component:  $T_0$ , 2.5 seconds;  $V$ , 49;  $J$ , 76 meters;  $e$ , 1.105;  $M$ , 105 kg.;  $L$ , 1.15 meters.

	FIRST PRELIMINARY TREMORS.		SECOND PRELIMINARY TREMORS.		PRINCIPAL PART.		MAX.	PERIOD.	AMPLITUDE.	EARTH'S AMPLITUDE.	
	<i>m.</i>	<i>s.</i>	<i>m.</i>	<i>s.</i>	<i>m.</i>	<i>s.</i>	<i>m.</i>	<i>s.</i>	<i>mm.</i>	<i>mm.</i>	
(1) North component . . . . .	25	12	35	57	54	18	00	21	20	55 +	1.4
(2) East component . . . . .	25	28	36	20	52	59	06	32	18	43	1.26
(3) North component . . . . .	..	..	..	..	56	44?	02	01	17	0.3	0.33
(4) East component . . . . .	..	..	..	..	51	24	00	32	19	0.55	0.64
Average . . . . .	25	20	36	08							
Interval . . . . .	12	52	23	40							

Duration, (1) 2 hours; (2) 1.8 hours; (3) 36 minutes; (4) 54 minutes. There is little concordance in the times of the principal part, and in the absence of the seismograms these values can not be used in the determination of the velocity.

The times, periods, and amplitudes are taken from the "Bulletin hebdomadaire des observatoires sismiques de la Hongrie et de la Croatie"; and the earth-amplitudes are calculated. The smaller amplitudes of the Vicentini instrument are probably more reliable than those of the Bosch-Omori instrument, for the period of the latter is so nearly that of the waves that its magnifying power is very uncertain. On the other hand the Vicentini failed to record the first and second preliminary tremors, indicating a lack of sensitiveness, possibly due to friction.

The Vicentini instrument at Zagreb, 30 km. further from the origin than O'Gyalla, indicates much larger amplitudes, but they also are very uncertain.

#### FIUME, HUNGARY.

Seismological Observatory. Dr. P. Salcher, director.

Lat. 45° 20' N.; long. 14° 26' E.; altitude, 20 meters; distance, 88.17° or 9,802 km.; chord, 8,863 km.; direction, N. 29° E.

Foundation, folded Cretaceous limestones.

The instrument used was a Vicentini-Konkoly pendulum, two components; mechanical registration on smoked paper.  $V$ , 86;  $M$ , 100 kg.;  $L$ , 1.70 ± meters. The movement begins on both components (north and east) at 13<sup>h</sup> 40<sup>m</sup> and reaches a maximum, north 54<sup>m</sup> 18", amplitude 0.8 mm.; east, 55<sup>m</sup> 18", amplitude 1.5 mm. The disturbance lasted 27.5 and 47 minutes, respectively, on the north and east components. It is not clear what phase the beginning of the movement refers to.

## FLORENCE (XIMENIANO), ITALY.

Osservatorio Ximeniano. P. G. Alfani, S. J., director.

Lat. 43° 47' N.; long. 11° 15' E.; distance, 88.23° or 9,808 km.; chord, 8,868 km.; direction, N. 31° E.

Foundation, alluvium.

Seismograms, sheet No. 6.

The instruments used were:

Stiattesi horizontal pendulums. (1) North and (2) east components:  $T_Q$  40 seconds;  $V$ , 30;  $J$ , 12,000 meters;  $M$ , 500 kg.;  $L$ , 1.50 meters.

Vicentini microseismograph. (3) North and east components:  $T_Q$  2.4 seconds;  $V$ , 100;  $J$ , 143 meters;  $M$ , 450 kg.;  $L$ , 1.43 meters.

Omori tromometrograph. (4) Northeast and (5) northwest components:  $T_Q$  36 seconds;  $V$ , 25;  $J$ , 8,100 meters;  $M$ , 250 kg.;  $L$ , 50 cm.

All have mechanical registration on smoked paper.

	FIRST PRELIMINARY TREMORS.		SECOND PRELIMINARY TREMORS.		PRINCIPAL PART.		MAX.	AMPLITUDE.	PERIOD.	EARTH'S AMPLITUDE.
	<i>m.</i>	<i>a.</i>	<i>m.</i>	<i>a.</i>	<i>m.</i>	<i>a.</i>	<i>mm.</i>	<i>mm.</i>	<i>sec.</i>	<i>mm.</i>
(1) North component . . . .	26	25	37	15	49	20	10.0	135 +	17.6	4.1 +
(2) East component . . . .	26	25	37	20	45	10	07.0	100 +	17.6	2.6 +
(3) North and east components	26	25	37	05	56	00	<i>ra.</i> 59 <i>a.</i> 50	...	....	...
(4) Northeast components . .	26	25	36	55	48	15	10 55	75	19	2.8
(5) Northwest component . .	26	25	36	45	47	25	08 05	100	22	1.9
Average . . . . .	26	25	37	04						
Interval . . . . .	13	57	24	36						

There are no time marks on the record of the Omori instruments, (4) and (5). Assuming the time of beginning to be the same as that given by the other instruments, the times of the later phases are obtained from the rate of rotation of the recording drum.

## ZAGREB (AGRAM), HUNGARY.

Seismological Observatory. Prof. Dr. Mohorovicsics.

Lat. 45° 49' N.; long. 15° 59' E.; distance, 88.33° or 9,820 km.; chord, 8,877 km.; direction, N. 27° E.

The instrument used was a Vicentini-Konkoly vertical pendulum, two horizontal components; mechanical registration on smoked paper. (1) North and (2) east components. The constants are assumed to be about the same as those for O'Gyalla, namely:  $T_Q$  2.5 seconds;  $V$ , 40;  $J$ , 62 meters;  $M$ , 105 kg.;  $L$ , 1.55 meters.

	FIRST PRELIMINARY TREMORS.		SECOND PRELIMINARY TREMORS.		PRINCIPAL PART.		MAX.	AMPLITUDE.	PERIOD.	EARTH'S AMPLITUDE.
	<i>m.</i>	<i>a.</i>	<i>m.</i>	<i>a.</i>	<i>m.</i>	<i>a.</i>	<i>mm.</i>	<i>mm.</i>	<i>sec.</i>	<i>mm.</i>
(1) North component . . . .	25	33	35	21	53	16	01 09	2.2	21	3.9
(2) East component . . . .	25	17	35	42	53	16	01 04	1.6	21	2.8
Average . . . . .	25	25	35	31	53	16				
Interval . . . . .	12	57	23	03	40	48				

The earth-amplitudes are quite uncertain on account of the uncertainties of the constants of the instrument.

The times, periods, and amplitudes are taken from the "Bulletin hebdomadaire des observatoires sismiques de la Hongrie et de la Croatie."

## POLA, AUSTRIA.

K. K. Hydrographisches-Amt. Prof. Dr. August Gratzl, director.

Lat. 44° 52' N.; long. 13° 51' E.; distance, 88.34° or 9,821 km.; chord, 8,877 km.; direction, N. 29° E.

The instrument used was a Vicentini microseismograph, three components; mechanical registration on smoked paper. The seismogram was too faint for reproduction.

(1) North and (2) east components:  $T_0$ , 2.24 seconds;  $V$ , 110';  $J$ , 138 meters;  $e$ , 1.03;  $r$ , 0.1 mm.;  $M$ , 100 kg.;  $L$ , 125 cm.

(3) Vertical component:  $T_0$ , 0.92 second;  $V$ , 135;  $J$ , 29 meters;  $M$ , 50 kg.

	FIRST PRELIMINARY TREMORS.		SECOND PRELIMINARY TREMORS.		REGULAR WAVES.		PRINCIPAL PART.		MAX.		AMPLITUDE.		PERIOD.		EARTH'S AMPLITUDE.	
	<i>m.</i>	<i>s.</i>	<i>m.</i>	<i>a.</i>	<i>m.</i>	<i>a.</i>	<i>m.</i>	<i>s.</i>	<i>m.</i>	<i>s.</i>	<i>mm.</i>	<i>sec.</i>	<i>mm.</i>			
(1) North component	25	56	36	13	46	05	54	29	09	29	1.6	14	0.5			
(2) East component	..	..	..	..	..	..	53	59	02	11	2.5	21	1.9			
Average . . . .	25	56	36	13	46	05	54	14								
Interval . . . .	13	28	23	45	33	37	41	46								

Nothing is visible in the vertical component. The greatest earth-amplitude on the north component was 1 mm. at 14<sup>h</sup> 04.0<sup>m</sup>.

## QUARTO-CASTELLO (FLORENCE), ITALY.

Osservatorio Geodinamico di Quarto-Castello. Dr. Raffaello Stiattesi, director.

Lat. 43°49' N.; long. 11° 16' E.; altitude, 90 meters; distance, 88.40° or 9,828 km.; chord, 8,882 km.; direction, N. 31° E.

Foundation, directly on Upper Eocene limestone.

Seismograms, sheet No. 6.

The instruments used were Stiattesi horizontal pendulums, two components; mechanical registration on smoked paper.

(1) North component:  $T_0$ , 21A seconds;  $V$ , 50;  $J$ , 3,780 meters;  $M$ , 500 kg.;  $L$ , 1.80 meters.

(2) East component:  $T_0$ , 17 A seconds;  $V$ , 50;  $J$ , 5,700 meters;  $M$ , 500 kg.;  $L$ , 1.80 meters.

	FIRST PRELIMINARY TREMORS.		SECOND PRELIMINARY TREMORS.		REGULAR WAVES.		PRINCIPAL PART.		MAX.		AMPLITUDE.		PERIOD.		EARTH'S AMPLITUDE.	
	<i>m.</i>	<i>a.</i>	<i>m.</i>	<i>a.</i>	<i>m.</i>	<i>a.</i>	<i>m.</i>	<i>s.</i>	<i>min.</i>	<i>mm.</i>	<i>sec.</i>	<i>mm.</i>				
(1) North component	26	35	37	10	52	39?	58	36	04	255 +	30	10.2 +				
(2) East component	26	42	36	58	51	24	....		07	265 +	17	1.2 +				
Average . . . .	26	38	37	04	52	01?										
Interval . . . .	14	10	24	36	39	33?										

The periods are shown on the seismogram. It is not clear why so large a movement of the earth is indicated on the north component. The foundation is limestone, and other stations, not far distant, record much smaller displacements; and the east component indicates an earth-amplitude only about 0.1 as much. This large amplitude can not be accepted as true.

## ZI-KA-WEI, CHINA.

Meteorological, Magnetic, and Seismological Observatory. Rev. Louis Froc, S. J., director.

Lat.  $31^{\circ} 12' N.$ ; long.  $121^{\circ} 26' E.$ ; altitude, 7 meters; distance,  $88.49^{\circ}$  or 9,838 km.; chord, 8,889 km.; direction, N.  $50^{\circ} W.$

Foundation, alluvium.

Seismograms, sheet No. 15.

The instrument used was an Omori horizontal pendulum, east component; mechanical registration on smoked paper.  $T_0$ , 33.2 seconds;  $V$ , 15;  $\lambda$ , 4,100 meters;  $e$ , 1.07;  $r$ , 1.5 mm.;  $M$ , 15 kg.;  $L$ , 75.6 cm.

	FIRST PRELIMINARY TREMORS.		(6) SKCOND PRELIMINARY TREMORS.		(d) REGULAR WAVES.		MAX.	AMPLITUDE.	PERIOD.
	<i>m.</i>	<i>s.</i>	<i>m.</i>	<i>s.</i>	<i>m.</i>	<i>s.</i>			
East component . . . .	25	24	35	36	56	00?	<i>min.</i>	N,	<i>sec.</i>
Interval . . . . .	12	56	23	08	43	32?	09	27	29.6

The beginning of the movement is not shown on the seismogram, and the beginning of the long waves is not very clear. At  $58^m$  the period of the waves is 26.4 seconds and the recorded amplitude 20 mm.; the actual magnifying power is 40.5, making the earth-amplitude 0.5 mm. At  $09^m$  the period is 29.6 seconds, the recorded amplitude 27 mm., and the magnifying power 60; and therefore the earth's amplitude is only 0.45 mm.

## PILAR, ARGENTINA.

Observatorio Magnetico. W. G. Davis, director.

Lat.  $31^{\circ} 40' S.$ ; long.  $63^{\circ} 50.5' W.$ ; altitude, 340 meters; distance,  $88.75^{\circ}$  or 9,866 km.; chord, 8,909 km.; direction, S.  $47^{\circ} E.$

Foundation, compact alluvium.

Seismograms, sheet No. 1.

The instrument used was a Milne horizontal pendulum, east component.  $T_{01}$  15 seconds;  $\gamma$ , 6.1;  $J$ , 340 meters;  $e$ , 1.076;  $M$ , 255 gin.;  $L$ , 15.6 cm.

First preliminary tremors,  $25.6^m$ ; interval, 13.1 minutes. Maximum,  $36.8^m$ ; interval, 24.3 minutes. Amplitude, 0.2 mm.

Duration, 1.3 hours. It is impossible to determine the beginning of the motion from the reproduction of the seismogram; it is only possible to see a small swelling at the time of the maximum, which apparently occurs during the second preliminary tremors. It is not clear why the record should have been so small.

## URBINO, ITALY.

Osservatorio Meteorico-Sismico. Prof. T. Allipi, director.

Lat.  $43^{\circ} 43' N.$ ; long.  $12^{\circ} 38' E.$ ; distance,  $88.82^{\circ}$  or 9,875 km.; chord, 8,916 km.; direction, N.  $30^{\circ} E.$

The instrument used was an Agamennone vertical pendulum (modified), two horizontal components; mechanical registration with ink on white paper.  $T_0$ , 5 seconds;  $V$ , 24;  $\lambda$ , 150 meters;  $M$ , 112 kg.;  $L$ , 6.2 meters.

(1) North component:  $13^h 54^m 50^s$  to  $14^h 16^m 00^s$ .\*

(2) East component:  $13^h 56^m 40^s$  to  $14^h 11^m 00^s$

Observations much too late; they probably represent only the principal part. The earlier phases were not recorded.

## ROCCA DI PAPA, ITALY.

It. Osservatorio Geodinamico. Prof. G. Agamennone, director.

Lat. 41° 46' N.; long. 12° 42' E.; altitude, 760 meters; distance, 90.48° or 10,061 km.; chord, 9,046 km.; direction, N. 32° E.

Foundation, volcanic rock.

Seismograms, sheet No. 14.

The instruments used were:

Microseismograph Agamennone, two components; mechanical registration with ink on white paper.

(1) Northwest component:  $T_0$ , 4.2 seconds;  $V$ , 60;  $L$ , 264 meters;  $e$ , 1.0;  $r$ , 0.38 mm.;  $M$ , 500 kg.;  $L$ , 4.39 meters.

(2) Northeast component:  $T_0$ , 4.2 seconds;  $V$ , 60;  $L$ , 264 meters;  $e$ , 1.0;  $r$ , 0.20 mm.;  $M$ , 500 kg.;  $L$ , 4.39 meters.

New microseismometrograph Agamennone (80 kg.), two components; mechanical registration on smoked paper.

(3) North and (4) east components:  $T_0$ , 2.6 seconds;  $V$ , 100;  $L$ , 168 meters;  $e$ , 1.0;  $r$ , 0.1 mm.;  $M$ , 80 kg.;  $L$ , 1.68 meters.

Cancani horizontal pendulums, two components; mechanical registration with ink on white paper.

(5) North component:  $T_0$ , 27.2 seconds;  $V$ , 1;  $J$ , 185 meters;  $e$ , 1.03;  $r$ , 0.0 mm.;  $M$ , 60 kg.;  $L$ , 1.00 meter (?).

(6) East component:  $T_0$ , 26.6 seconds;  $V$ , 1;  $L$ , 176 meters;  $e$ , 1.06;  $r$ , 0.0 mm.;  $M$ , 60 kg.;  $U$ , 1.76 meters;  $L$ , 1.00 meter(?).

	SECOND PRELIMINARY TREMORS.		REGULAR WAVES.		PRINCIPAL PART.		MAX.	AMPLITUDE.	PERIOD.	EARTH'S AMPLITUDE.
	m.	«.	m.	s.	m.	s.				
(1) Northwest component	36	15	56	25?	..	..	07.3	3.2	19	1.15
(2) Northeast component	36	57	57	25?	57	29	<sup>m.</sup> <sup>s.</sup> 10 11	2.0	17	0.5
(3) North component . .	..	..	57	50?	06	00	07 00	2.0	17	0.8
(4) East component . . .	35	46	58	14?	03	20?	07 30	2.0	17	0.8
(5) North component . . .	36	34	57	50	59	15	05 20	12.5	26	
(6) East component . . .	37	00	57	15	01	25	04 14	15.0	27	
Average . . . . .	36	30	57	30						
Interval . . . . .	24	02	45	02						

Duration, 2 hours. The beginning of the motion on all the instruments was masked by vibrations due to high winds.

The seismograms are reproduced from tracings, which, in the case of the 80 kg. Agamennone seismograph, do not bring out the regularity and fineness of the original record on smoked paper. One sees, however, the short vibrations of the pendulum superposed on the larger earth vibrations. The greatest earth-amplitude was at 14<sup>h</sup> 07.3<sup>m</sup>; the 500 kg. seismograph indicates an amplitude of 1.1 mm. in the northwest direction, and the two components of the 80 kg. instrument indicate: North, 0.82 mm.; east, 1.14 mm.; a total amplitude of about 1.4 mm. in the northwest or northeast direction. These instruments therefore partially confirm each other and indicate that the maximum motion was in the line of propagation.

The Cancani horizontal pendulums have no damping; and since their natural periods correspond closely to those of the disturbance, no conclusion can be drawn from their record regarding the earth's amplitude.

## BELGRADE, SERVIA.

Royal Astronomical and Meteorological Observatory. Prof. Dr. M. Nedelkovitch, director.

Lat.  $44^{\circ} 48' N.$ ; long.  $20^{\circ} 09' E.$ ; distance,  $90.67^{\circ}$  or 10,080 km.; chord, 9,061 km.; direction, N.  $25^{\circ} E.$

Foundation, argillaceous alluvium, 130 meters thick, on Cretaceous limestones.

The instrument used was a Vicentini-Konkoly microseismograph, two components; mechanical registration on smoked paper.

(1) North component:  $T_Q$ , 2.4 seconds;  $V$ , 33;  $J$ , 47 meters;  $M$ , 105 kg.;  $L$ , 1.43 meters.

(2) East component:  $T_Q$ , 2.4 seconds;  $V$ , 48;  $J$ , 63 meters;  $M$ , 105 kg.;  $L$ , 1.43 meters.

Average: Second preliminary tremors,  $36^m 54^s$ ; interval,  $24^m 26^s$ . Maximum,  $02^m 51^s$ . Amplitude, 1.0 mm.

Duration, 1.9 hours.

## CARLOFORTE, SARDINIA, ITALY.

Stazione Astronomica Internazionale. Dr. L. Volta, director.

Lat.  $39^{\circ} 08' N.$ ; long.  $80^{\circ} 19' E.$ ; altitude, 18 meters; distance,  $90.71^{\circ}$  or 10,085 km.; chord, 9,067 km.; direction, N.  $36^{\circ} E.$

Foundation, trachitic rock.

The instrument used was a Vicentini microseismograph, two horizontal components; mechanical registration on smoked paper.

Northwest and northeast components:  $T_Q$ , 2.2 seconds;  $V$ , 50;  $J$ , 60 meters;  $e$ , 1.0;  $r$ , 0.1 (northwest component), 0.05 (northeast component);  $M$ , 100 kg.;  $L$ , 1.20 meters;

The original seismogram (too faint for reproduction) does not give clearly the times of the phases, but it shows, at  $14^h 07^m$ , waves of period 17 seconds and amplitude 0.5 mm.; as the magnifying power for these waves is 0.85, the earth's amplitude at that time was 0.6 mm., and since this amplitude was common to both components, the total possible amplitude of the earth's movement was 0.85 mm. At  $14^h 02^m$  the northeast component shows waves of period 20.4 seconds and amplitude 0.2 mm., indicating an amplitude of the earth in that direction of 0.34 mm. On the northwest component the amplitude is 0.2 mm., and period 27 seconds, therefore the earth's amplitude is 0.6 mm.; the movement at this time has a stronger component in the northwest direction, that is, in the direction of propagation.

## SARAJEVO, BOSNIA.

Meteorologisches Bureau. Herr Ph. Ballif, director; Herr Passinij, section chief.

Lat.  $43^{\circ} 52' N.$ ; long.  $18^{\circ} 26' E.$ ; altitude, 633 meters; distance,  $90.89^{\circ}$  or 10,104 km.; chord, 9,078 km.; direction, N.  $27^{\circ} E.$

Foundation, clay; on northern slope of a hill.

Seismograms, sheet No. 15.

The instrument used was a Vicentini microseismograph, two horizontal components; mechanical registration on smoked paper.

(1) North component:  $T_Q$ , 2.2 seconds;  $V$ , 156;  $J$ , 188 meters;  $M$ , 100 kg.;  $L$ , 1.20 meters.

(2) East component:  $T_Q$ , 2.2 seconds;  $V$ , 138;  $J$ , 166 meters;  $M$ , 100 kg.;  $L$ , 1.20 meters.

■

	SECOND PRELIMINARY TREMORS.		PRINCIPAL PART.		MAX.		AMPLITUDE.	PERIOD.	EARTH'S AMPLITUDE.
	TO.	8.	m.	8.	m.	8.	mm.	sec.	mm.
(1) North component	40	05	57	47?	03	40	0.4	30	0.47
(2) East component	33	10	54	16 ?	03	40	0.75	25	0.7
					14	39.5	1.0	20	0.6

Duration, 1 hour. The first preliminary tremors are not recorded, but a bell connected with a seismoscope rang at 13<sup>h</sup> 25<sup>m</sup>. The east component began to record earlier than the north, and thruout gave much larger amplitudes. The maximum movement of the ground was at 14<sup>h</sup> 03.7<sup>m</sup> and amounted to about 0.54 mm.; at 14<sup>h</sup> 10.5<sup>m</sup> it was 0.46 mm.; its direction was nearly east-west.

#### ISCHIA, ITALY.

R. Osservatorio Geodinamico di Casamicciola. Two installations, one at Porto d'Ischia and one at Grande Sentinella, about 3 km. apart. Prof. G. Grablowitz, director.

#### PORTO D'ISCHIA.

Lat. 40° 44' N.; long. 13° 57' E.; altitude, 31 meters; distance, 91.84° or 10,211 km.; chord, 9,153 km.; direction, N. 31° E.

Foundation, trachite.

Seismograms, sheet No. 7.

The instruments used were:

Grablowitz horizontal pendulums, two components:

(1) North component:  $T_0$ , 17 seconds;  $V$ , 8;  $J$ , 570 meters;  $e$ , 1.24;  $r$ , 0.8 mm.;  $M$ , 12 kg.;  $L$ , 8 cm.

(2) East component:  $T_0$ , 17 seconds;  $V$ , 8;  $J$ , 570 meters;  $e$ , 1.07;  $r$ , 0.2 mm.;  $M$ , 12 kg.;  $L$ , 8 cm.

Vasea Sismica, two horizontal components. This is a circular tank containing water; two floats are placed near the sides at ends of a north-south and of an east-west diameter respectively, and the movement of the water is magnified and recorded on a drum. The tank is 1.56 meters in diameter and the water is one meter deep. The movement of the north-south diameter is magnified 74.4 times, that of the east-west diameter 68.6 times.

#### GRANDE SENTINELLA.

Lat. 40° 45' N.; long. 13° 54' E.; altitude, 122 meters; distance, 91.83° or 10,210 km.; chord, 9,151 km.; direction, N. 31° E.

Foundation, volcanic tuff.

Seismograms, sheet No. 7.

The instruments used were:

(5) Grablowitz horizontal pendulum, east component:  $T_0$ , 12 seconds;  $V$ , 8;  $J$ , 290 meters;  $e$ , 1.18;  $r$ , 0.5 mm.;  $M$ , 12 kg.;  $L$ , 10 cm.

(6) and (7) Vasca Sismica, two components; it has the same dimensions as the tank at Porto d'Ischia.  $V$ , 90.7 for the north component and 97.3 for the east component.

All the instruments at both stations record on smoked paper.



	FIRST PRELIMINARY TREMORS.		SECOND PRELIMINARY TREMORS.		REGULAR WAVES.		PRINCIPAL PART.		MAX.		AMPLITUDE.	PERIOD.
	<i>m.</i>	<i>s.</i>	<i>m.</i>	<i>a.</i>	<i>m.</i>	<i>s.</i>	<i>m.</i>	<i>s.</i>	<i>m.</i>	<i>s.</i>	<i>mm.</i>	<i>sec.</i>
(1) North component . . . . .	..	..	36	49?	..	..	<b>07</b>	<b>00</b>	08	34	25	<b>17</b>
(2) East component . . . . .	..	..	..	..	..	..	<b>04</b>	<b>31</b>	08	27	50	<b>17</b>
(5) East component . . . . .	26	42?	<b>37</b>	<b>07</b>	56	24	<b>04</b>	<b>00</b>	10	25	<b>7.5</b>	<b>12.6</b>
Average . . . . .	26	42?	36	58	56	24						
Interval . . . . .	<b>14</b>	<b>14?</b>	24	<b>30</b>	43	56						

The vibrations of the water make it impossible to determine the phases from the Vasca Sismica either at Porto d'Ischia or at Grande Sentinella; at the former distinct waves of period about 18 seconds and amplitude 0.6 mm. occur from 14<sup>b</sup> 04.0<sup>m</sup> to 14<sup>b</sup> 18.0<sup>m</sup>. At Grande Sentinella, the waves are discernible at 13<sup>h</sup> 56.0<sup>m</sup>; a maximum with amplitude of nearly 1 mm. is reached at 14<sup>b</sup> 07.0<sup>m</sup>; the periods are from 18 to 24 seconds.

During the strong motion the periods of the vibrations recorded by the Grablowitz pendulums are the same as those of the pendulums themselves; namely, 17 seconds at Porto d'Ischia and 12 seconds at Grande Sentinella. If we attempt to find the earth-amplitudes by using the values of the damping and friction, we find 0.33 mm. or less; but it is evident that the regular movement did not continue long enough to allow the pendulums to take their full amplitudes.

## CAGGIANO (SALERNO), ITALY.

Osservatorio Meteorologico-Geodinamico. Signor P. Allard, director.

Lat. 40° 54' N.; long. 15° 30' E.; altitude, 831 meters; distance, 92.63° or 10,297 km.; chord, 9,213 km.; direction, N. 30° E.

The instrument used was an Agamennone seismometrograph, northwest and southwest components; mechanical registration with ink on white paper.  $T_0$  6 seconds;  $V$ , 12.5;  $J$ , 112 meters;  $M$ , 200 kg.;  $L$ , 8.95 cm.

	SECOND PRELIMINARY TREMORS.		REGULAR WAVES.		MAX.		AMPLITUDE.	PERIOD.	EARTH'S AMPLITUDE.
	<i>m.</i>	<i>s.</i>	<i>m.</i>	<i>a.</i>	<i>m.</i>	<i>a.</i>	<i>mm.</i>	<i>sec.</i>	<i>mm.</i>
Northwest component . . . . .	36	<b>40</b>	<b>56</b>	<b>46</b>	<b>04</b>	<b>10</b>	<b>0.9</b>	<b>22</b>	<b>0.95</b>
Interval . . . . .	<b>24</b>	<b>12</b>	<b>44</b>	<b>18</b>					

At 13<sup>b</sup> 59.5<sup>m</sup> the long waves on the northwest component had an amplitude of 0.4 mm. and a period of 32 seconds, corresponding to an earth-amplitude of 1 mm. At 14<sup>b</sup> 07.3<sup>m</sup> the northwest earth-amplitude was 0.68 mm. The northeast component was not perfectly free and was less sensitive than the northwest, so that the times can not be made out reliably; but notwithstanding this it indicated an earth-amplitude of 2.2 mm. at 14<sup>b</sup> 04.2<sup>m</sup>; denoting the strongest motion at right angles to direction of propagation.

The seismogram arrived too late for reproduction.

## TAIHOKU, FORMOSA, JAPAN.

Meteorological Observatory. H. Kondo, director.

Lat. 25° 04' N.; long. 121° 31' E.; altitude, 10 meters; distance, 92.75° or 10,311 km.; chord, 9,222 km.; direction, N. 55° W.

Foundation, clay.

Seismograms, sheet No. 15.

The instrument used was an Omori horizontal pendulum, east component; mechanical registration on smoked paper.  $T_0$ , 17 seconds;  $V$ , 10;  $l$ , 720 meters;  $e$ , 1.27;  $r$ , 0.13

mm.;  $M$ , 6 kg.;  $L$ ,  $76 \pm$  cm. The times on the seismogram are  $a$ ,  $13^h 38^m 52^s$ ;  $b$ ,  $13^h 56^m 20^s$ ;  $c$ ,  $14^U 20^m 27^s$ ;  $d$ ,  $15^U 00^m 48^s$ .

	(a) PRELIMINARY TREMORS.		(b) REGULAR WAVES.		MAX.	AMPLITUDE.	PERIOD.	EARTH'S AMPLITUDE.
	<i>m.</i>	<i>a.</i>	<i>m.</i>	<i>a.</i>	<i>min.</i>	<i>mm.</i>	<i>sec.</i>	<i>mm.</i>
East component . . . . .	28	52	56	20	0.0	3.5	22	0.25
Interval . . . . .	16	24	43	52				

The time of the beginning is evidently too late. It is probable that the earth-amplitude was greater than calculated, as the large vibration lasted for a very short time.

## SOFIA, BULGARIA.

Central Meteorological Institute. Dr. Spas Watzof, director.

Lat.  $42^\circ 42'$  N.; long.  $23^\circ 20'$  E.; altitude, 550 meters; distance,  $93.58^\circ$  or 10,404 km.; chord, 9,286 km.; direction, N.  $24^\circ$  E.

Foundation, sands and sandy shales.

Seismograms, sheet No. 13.

The instruments used were Bosch-Omori horizontal pendulums, two horizontal components; mechanical registration on smoked paper.

(1) North component:  $T_o$ , 20.8 seconds;  $V$ , 10.1;  $J$ , 108 meters;  $e$ , 1.0;  $r$ , 2.7 mm.;  $M$ , 10 kg.;  $L$ , 74 cm.

(2) East component:  $T_o$ , 31.0 seconds;  $V$ , 10.1;  $J$ , 2,400 meters;  $e$ , 1.0;  $r$ , 4.0 mm.;  $M$ , 10 kg.;  $L$ , 74 cm.

	(a) FIRST PRELIMINARY TREMORS.	(6) SECOND PRELIMINARY TREMORS.	REGULAR WAVES.	PRINCIPAL PART.	MAX.	AMPLITUDE.	PERIOD.
	<i>min.</i>	<i>min.</i>	<i>min.</i>	<i>min.</i>	<i>min.</i>	<i>mm.</i>	<i>sec.</i>
(1) North component	25.00	35.5	57.5	03.0	04.7 to 05.8	50 +	21.9
(2) East component	.....	36.0	56.7	.....	.....	60 +	28.9
Average . . . . .	25.00	35.45	57.06				
Interval . . . . .	12.32	23.17	44.38				

During the long waves at  $14^h 01.5^m$ , the north earth-amplitude was 0.48 mm. During the maximum movement of the pendulums the periods of vibration correspond very nearly to the proper periods of the pendulums; we can not therefore determine the earth's movement. It is very difficult to determine the times of the first and second preliminary tremors accurately; nor is it clear where we should place the beginning of the regular waves.

## MESSINA, SICILY, ITALY.

Instituto di Fisica terrestre e Meteorologia della R. Università. Prof. B. G. Rizzo, director.

Lat.  $38^\circ 12'$  N.; long.  $15^\circ 33'$  E.; altitude, 46 meters; distance,  $94.67^\circ$  or 10,524 km.; chord, 9,368 km.; direction, N.  $32^\circ$  E.

Seismograms, sheet No. 12.

The instrument used was a Vicentini microseismograph, three components; mechanical registration on smoked paper.

(1) Northeast component:  $T_o$ , 2.4 seconds;  $V$ , 100;  $J$ , 143 meters;  $M$ , 106 kg.;  $L$ , 1.43 meters.

(2) Northwest component:  $T_o$ , 2.4 seconds;  $V$ , 100;  $J$ , 143 meters;  $e$ , 1.04;  $M$ , 106 kg.;  $L$ , 1.43 meters.

(3) Vertical component:  $T_{Q_1}$  1.8 seconds;  $V$ , 120;  $J$ , 97 meters;  $\epsilon$  1.14;  $M$ , 56 kg.

The records were greatly disturbed by the wind so that the times of arrival of the first two phases were entirely lost; the long waves appear at 13<sup>h</sup> 55.5<sup>m</sup> on the northwest component. The greatest movement of the earth occurred during the principal part, at  $M_2$  (14<sup>h</sup> 07.8<sup>m</sup>); when we find

	AMPLITUDE.	PERIOD.	EARTH'S AMPLITUDE.
	<i>mm.</i>	<i>sec.</i>	<i>mm.</i>
Northwest component . . .	2.0	22	1.66
Northeast component . . .	0.4	21	0.30
Vertical component . . .	0.2	22	0.25

As a possible maximum of the earth-amplitude we have 1.7 mm. During the long waves, at 14<sup>h</sup> 04.7<sup>01</sup>, the period was 30 seconds, and the earth-amplitude 0.93 mm. The letters on the seismogram correspond to times as follows:  $M_v$  14<sup>h</sup> 04.3<sup>m</sup>;  $M_2$ , 14<sup>h</sup> 07.8<sup>m</sup>;  $M_8$ , 14<sup>h</sup> 10.1<sup>m</sup>;  $M_{\downarrow}$  14<sup>h</sup> 12.7<sup>m</sup>.

CATANIA, SICILY, ITALY.

R. Osservatorio di Catania ed Etneo. Prof. A. Riccd, director.  
 Lat. 37°30' N.; long. 15°05' E.; altitude, 42 meters; distance, 95.04° or 10,567 km.;  
 chord, 9,396 km.; direction, N. 32° E.  
 Foundation, lava.  
 Seismograms, sheet No. 13.

The instrument used was a long vertical pendulum, two horizontal components; mechanical registration with ink on white paper.

(1) Northeast component:  $T_{Q_1}$  10 seconds;  $V$ , 12.5;  $J$ , 310 meters;  $e$ , 1.01;  $r$ , 0.4 mm.;  $M$ , 300 kg.;  $L$ , 24.9 meters.

(2) Northwest component:  $T_{Q_1}$  10 seconds;  $V$ , 12.5;  $J$ , 310 meters;  $e$ , 1.026;  $r$ , 0.5 mm.;  $M$ , 300 kg.;  $L$ , 24.9 meters.

	FIRST PRELIMINARY TREMORS.		SECOND PRELIMINARY TREMORS.		REGULAR WAVES.		PRINCIPAL PART.		MAX.	AMPLITUDE.	PERIOD.	EARTH'S AMPLITUDE.
	<i>m.</i>	<i>a.</i>	<i>m.</i>	<i>s.</i>	<i>m.</i>	<i>t.</i>	<i>m.</i>	<i>s.</i>				
(1) Northeast component	26	05	37	27	56	24	04	45	12	51	18	0.72
(2) Northwest component	26	05	35	23	..	..	06	50	07	08	18	0.72
Average . . . . .	26	05	36	25?	56	24	05	48?				
Interval . . . . .	13	37	23	57?	43	56	53	20?				

At the times of the maximum on each component the movement is comparatively small on the other component, so that the total earth-amplitude would not be more than about 0.8 mm. The northwest component shows signs of friction; this may be the reason why it does not bring out the long waves, and why the principal part is of somewhat shorter duration than on the northeast component.

RIO DE JANEIRO, BRAZIL.

Observatorio de Rio de Janeiro. Dr. H. Morize, director.  
 Lat. 22° 54' S.; long. 43° 10' W.; altitude, 44 meters; distance, 96.28° or 10,703 km.; chord, 9,488 km.; direction, S. 66° E.  
 Foundation, decomposed gneiss.

The instruments used were Bosch-Omori horizontal pendulums, two horizontal components; mechanical registration on smoked paper.  $M$ , 15 kg.;  $V$ , 15.

The solid friction was so strong that it rendered the pendulums almost aperiodic and masked the details of the motion; for this reason the seismogram is not reproduced. The first movement discernible on the east component is at 13<sup>h</sup> 39.7<sup>m</sup>; and on the north component at 13<sup>h</sup> 54<sup>m</sup>. The total duration is nearly an hour.

## WELLINGTON, NEW ZEALAND.

Department of Education. G. Hogben, director.

Lat. 41° 17' S.; long. 174° 47' E.; altitude, 15 meters; distance, 97.62° or 10,853 km.; chord, 9,588 km.; direction, S. 42° W.

Foundation, directly on the "Wellington Slates" near the edge of a cliff, 15 meters high, near Wellington Harbor.

Seismograms, sheet No. 2.

The instrument used was a Milne horizontal pendulum, east component; photographic registration.  $T_0$ , 18.6seconds;  $V$ , 6.1;  $J$ , 525meters;  $e$ , 0.14;  $M$ , 255 gm.;  $L$ , 15.6 cm.

	FIKBT PRELIMINARY TREMORS.	SECOND PRELIMINARY TREMORS.	PRINCIPAL PART.
East component. . . . .	<i>min.</i> 26.6	<i>min.</i> 36.8	<i>min.</i> 02.2 (?)
Interval . . . . .	14.1	24.3	49.7 (?)

## CALAMATE, GREECE.

National Astronomical Observatory. Prof. Dr. D. Eginitis, director.

Lat. 37° 02' N.; long. 22° 15' E.; altitude, 32 meters; distance, 98.28° or 10,927 km.; chord, 9,636 km.; direction, N. 28° E.

Seismograms, sheet No. 15.

The instrument used was an Agamennone vertical pendulum, two horizontal components; mechanical registration with ink on white paper.  $T_0$ , 6.95 ± seconds;  $V$ , 12;  $L$ , 144 meters;  $M$ , 200 kg.;  $L$ , 1.44 m.

The disturbance began at 14<sup>h</sup> 02<sup>m</sup> 06<sup>s</sup> and lasted 18 minutes. Evidently the preliminary tremors were not recorded, but only the principal part, whose interval is 49<sup>m</sup> 38<sup>s</sup>.

## TIFLIS, CAUCASIA, RUSSIA.

Physical Observatory. Herr S. von EQasek, director.

Lat. 41° 43' N.; long. 44° 48' E.; distance, 99.43° or 11,054 km.; chord, 9,719 km.; direction, N. 9° E.

The instruments used were:

Ehlertr triple horizontal pendulum, photographic registration.

Milne horizontal pendulum, photographic registration, east component.

Bosch-Omori horizontal pendulums, two components; mechanical registration on smoked paper.

Two heavy Zöllner horizontal pendulums.<sup>1</sup>

First preliminary tremors, 26<sup>m</sup> 09<sup>s</sup>; interval, 13<sup>m</sup> 41<sup>s</sup>. Second preliminary tremors, 37<sup>m</sup> 59<sup>s</sup>; interval, 25<sup>m</sup> 31<sup>s</sup>.

## TASCHKENT, RUSSIAN TURKESTAN.

Astronomical and Physical Observatory. M. Ossipoff, director.

Lat. 41° 20' N.; long. 69° 18' E.; altitude, 478 meters; distance, 99.86° or 11,102 km.; chord, 9,750 km.; direction, N. 9° W.

Foundation, stiff loess.

<sup>1</sup> The times are taken from "Die Erdbebenwellen" by Drs. Wiechert and Zoeppritz. Nach. d. Gesell. d. Wissen. Glittingen, Math. Phys. Kl. 1907. No further information is given.

The instruments used were:

Repsold-Zöllner horizontal pendulums, two components; photographic registration. Seismograms, sheet no. 2.

(1) North component:  $T_0$ , 9.2 seconds; F, 59; J, 1,240 meters; M, 59.1 gm.; L, 13 cm.

(2) East component:  $T_0$ , 7.94 seconds; V, 60; J, 940 meters; M, 59.1 gm.; L, 12.7 cm.

Bosch-Omori horizontal pendulums, two components; mechanical registration on smoked paper. Seismograms, sheet No. 13.

(3) North and (4) east components:  $T_0$ , 12 seconds; F, 10 (?); J, 360 (?) meters; M, 11 kg.; L, 75 cm.

	HHBT PRE-LIMINART TREMORS.	SECOND PRELIMINARY TREMORS.	REGULAR WAVES.	PRINCIPAL PART.	MAX.	AMPLITUDE.	PERIOD.	EARTH'S AMPLITUDE.
(1) North component	<i>min.</i> 26.5	<i>min.</i> (31.0)	<i>min.</i> (43.0)	m. a. .....	m. a. .....	<i>mm.</i> 80 +	<i>sec.</i> .....	<i>mm.</i> .....
(2) East component	(30.7)	37.8	48.4	.....	.....	80 +	.....	.....
(3) North component	.....	<i>m.</i> 36 <i>a.</i> 56	<i>m.</i> 53 <i>a.</i> 20	<i>m.</i> 09 <i>a.</i> 56	<i>m.</i> 10 <i>a.</i> 56	10	<b>24</b>	3.0
(4) East component	(5L26)	(59 06)	(06 08)	(14 27)	(21 21)	33	<b>32</b>	.....
Average	26.5	37 22						
Interval	14.0	24 54						

The times in parentheses are not used, as they are evidently erroneous; the cause is unknown; the times of (4), for instance, are all much too late, but I can not discover the cause. (4) also indicates an earth-amplitude of 20 mm., which is impossible.

#### CHRISTCHURCH, NEW ZEALAND.<sup>1</sup>

Magnetic Observatory. Henry F. Skey, B. Sc, director.

Lat. 43° 3# S.; long. 172° 37' E.; distance, 100.40° or 11,162 km.; chord, 9,788 km.; direction, S. 42° W.

The instrument used was a Milne horizontal pendulum, east component; photographic registration. V, 6.1; M, 255 gm.; L, 15.6 cm.

East component: Second preliminary tremors, 33.6<sup>m</sup>; interval, 21.1 minutes. Regular waves, 01.0<sup>m</sup>, interval, 48.5 minutes. Maximum, 30.0<sup>m</sup>. Amplitude, 6.8 mm. Duration, 3.3 hours.

#### MANILA, PHILIPPINE ISLANDS.

Manila Central Observatory. Rev. Jose<sup>a</sup> Algue<sup>a</sup>, S. J., director.

Lat. 14° 35' N.; long. 120° 59' E.; altitude, 10 meters; distance, 100.46° or 11,169 km.; chord, 9,793 km.; direction, S. 118° W.

Foundation, sand 14 meters thick over volcanic tuff.

Seismograms, sheet No. 4.

The instrument used was a Vicentini microseismograph, two horizontal and vertical components; mechanical registration on smoked paper. East-northeast component:  $T_0$ , 2.4 seconds; J, 100; J, 1,430 meters; M, 100 kg.; L, 1.43 meters.

	FIRST PRE-LIMINARY TREMORS.	REGULAR WAVES.	MAX.	AMPLITUDE.	PERIOD.
East-northeast component	<i>m.</i> 22 <i>a.</i> 44	01.0	<i>min.</i> 08.0	<i>mm.</i> <b>0.9</b>	<i>sec</i> 18
Interval	10 16	48.5			

<sup>1</sup> The times are taken from Circular 15, issued by the Seismological Committee of the British Association for the Advancement of Science.

Duration, 3 hours. The time of the beginning is evidently too early; the smallness of the motion makes it quite impossible to determine the precise time. The north-northwest component (not reproduced) gives a record very similar to the other, but with a somewhat smaller amplitude. The maximum instrumental amplitude is at 14<sup>h</sup> 08.0<sup>m</sup>, when the earth-amplitude was (ENE.) 0.44 mm., (NNW.) 0.4 mm., or a possible total of 0.6 mm. Data are not at hand to determine the vertical earth movement, tho the instrumental amplitude was 0.25 mm. A larger earth-amplitude occurred during the long waves; we find, at 14<sup>h</sup> 01.0<sup>m</sup>, earth-amplitudes (ENE.) 0.75 mm., (NNW.) 0.45 mm., or a possible total of 0.87 mm. If instead of a short-period pendulum there had been one with a period in the neighborhood of 25 seconds, the record would have been very large at this time; and if the period had been about 20 seconds, the record would have been very large at 14<sup>h</sup> 08.0<sup>m</sup>; as it is, with a period of 2.4 seconds, the record is quite small. The strong contrast between the seismograms of Manila and that of Potsdam, on the same plate, is principally due to the periods of the pendulums at the respective places. At Potsdam the period was 18 seconds.

## TADOTSU', JAPAN.

Meteorological Observatory. N. Maeda, director.

Lat. 34° 17' N.; long. 133° 46' E.; altitude, 6 meters; distance, 101.30° or 11,262 km.; chord, 9,852 km.; direction, N. 55° W.

The instrument used was an Omori horizontal pendulum; mechanical registration on smoked paper.  $M$ , 10 kg.;  $V$ , 20;  $L$ , 75 cm.<sup>1</sup>

First preliminary tremors, 25<sup>m</sup> 07<sup>s</sup>; interval, 12 minutes 39 seconds.

## CAIRO, EGYPT.

Helwan Observatory. H. H. Wade, director.

Lat. 29° 52' N.; long. 31° 20.5' E.; altitude, 115 meters; distance, 107.92° or 11,998 km.; chord, 10,302 km.; direction, N. 23° E.

Foundation, directly on Eocene limestones; in the desert about 5 km. from the Nile. Seismograms, sheet No. 1.

The instrument used was a Milne horizontal pendulum, east component; photographic registration.  $T_0$ , 15 seconds;  $V$ , 6.1;  $l$ , 340 meters;  $e$ , 1.054; angular displacement, 1 mm. = 0.5<sup>''</sup>;  $M$ , 255 gm.;  $L$ , 15.6 cm.

	FIRST PRELIMINARY TREMORS.	SECOND PRELIMINARY TREMORS.	MAX.	AMPLITUDE.
East component . . .	<i>min.</i> 31.0?	<i>min.</i> 39.0?	14*34.0-»	<i>mm.</i> 4.0
Interval . . .	18.5?	26.5?		

Duration, 3.5 hours. Only a drawing of the seismogram was available; this and the indefinite character of the seismogram make it impossible to obtain accurate time determinations of the various phases. The beginning of the first preliminary tremors are evidently too late, but the time of the second preliminary tremors seems about right.

<sup>1</sup> The constants are taken from Professor Omori's Report on the Great Indian Earthquake. "Pub. Earthquake Investigation Commission in Foreign Language, No. 24." The time is taken from Bulletin of the same Commission, vol. 1, No. 1.

## CALCUTTA, INDIA.

Alipore Meteorological Observatory. G. W. Kiichler, assistant meteorological reporter.  
Lat.  $22^{\circ} 32' N.$ ; long.  $88^{\circ} 20' E.$ ; altitude, 6.5 meters; distance,  $112.72^{\circ}$  or 12,531  
km.; chord, 10,607 km.; direction,  $N. 31^{\circ} W.$

Foundation, marshy alluvium; 100 km. from the sea, and far from mountains.  
Seismograms, sheet No. 1.

The instrument used was a Milne horizontal pendulum, east component; photographic registration.  $T_o$ , 18 seconds;  $V$ , 6.1;  $J$ , 490 meters;  $e$ , 1.10; angular displacement, 1 mm. = 0.38";  $M$ , 255 gm.;  $L$ , 15.6 cm.

	FIRST PRE- LIMINARY TREMORS.	SECOND PRE- LIMINARY TREMORS.	REGU- LAR WAVES.	MAX.	AMPLI- TUDE.
East component . . .	<i>T</i> <sub>min.</sub> 29.2?	<i>t</i> <sub>min.</sub> 39.4	<i>min.</i> 05.6?	<i>min.</i> 17.3	<i>mm.</i> 17
Interval . . .	16.7?	26.9	53.1?		

Duration, 4.1 hours. It is difficult to determine the exact time of beginning, as there was a slight disturbance of the beam. The time of the second preliminary tremors is less doubtful.

## BOMBAY, INDIA.

Government Observatory. N. A. F. Moos, director.

Lat.  $18^{\circ} 54' N.$ ; long.  $72^{\circ} 49' E.$ ; altitude, 11 meters; distance,  $121.19^{\circ}$  or 13,472  
km.; chord, 11,099 km.; direction,  $N. 17^{\circ} W.$

Foundation, basaltic trap.

The instruments used were:

(1) Milne horizontal pendulum, east component; photographic registration. Seis-  
mograms, sheet No. 2.  $T_o$ , 18 seconds;  $V$ , 6.1;  $J$ , 490 meters; angular displacement,  
1 mm. = 0.47";  $M$ , 255 gm.;  $L$ , 15.6 cm.

Colaba horizontal pendulums, two components; mechanical registration with ink on  
paper. Seismograms, sheet No. 15.

(2) North component:  $T_o$ , 24 seconds;  $V$ , 3;  $J$ , 430 meters; angular displacement,  
1 mm. = 0.27";  $M$ , 25 kg.;  $L$ ,  $92 \pm$  cm.

(3) East component:  $T_o$ , 37 seconds;  $V$ , 5;  $J$ , 1,700 meters; angular displacement,  
1 mm. = 0.14";  $M$ , 25 kg.;  $L$ ,  $92 \pm$  cm.

Each one of the Colaba pendulums consists of a mass of about 25 kg., supported on a  
horizontal beam about 90 cm. long. The solid friction is large, sufficient to stop the  
vibration of the pendulum in a single vibration if its amplitude is not more than a few  
millimeters.

	S»com>PHB- LMIKART TREMORS.	<i>W</i> <sub><i>x</i></sub> <i>r</i> <i>m.</i>	MAX.	AMPW TTOS.
(1) East component . . .	40.8	<i>min.</i> 11.8	<i>min.</i> 34.1	<i>min.</i> 6.3
(2) North component . . .	42.5?	...	27.9	3.6
(3) East component . . .	42.5T	...	29.0	4.0
Average . . . . .	40.8	11.8		
Interval . . . . .	28.3	59.3		

Duration, 3.4 hours. (1) gives a better value of the time of arrival of the second  
preliminary tremors than the average on account of the strong fraction of (2) and (3);  
and therefore its value is used in preference to the average of the three installment!. The

time of arrival of the regular waves is doubtful; at the time given there is a change in the general character of the record, the irregular phase becoming more regular and the amplitude larger. The friction alters the magnifying power very materially; in the absence of precise knowledge of its value we can not estimate the earth's amplitude.

## BATAVIA, JAVA.

Royal Magnetic and Meteorological Observatory. Dr. W. van Bemmelen, acting director.

Lat.  $6^{\circ} 11' S.$ ; long.  $106^{\circ} 50' E.$ ; altitude, 3 meters; distance,  $124.99^{\circ}$  or 13,897 km.; chord, 11,300 km.; direction, S.  $112^{\circ} W.$

Foundation, alluvium.

Seismograms, sheet No. 15.

The instrument used was a Rebeur-Ehler horizontal pendulum, north component; photographic registration.  $T_o$ , 9.4 seconds;  $F$ , 65.5;  $J$ , 1,440 meters;  $e$ , 1.15;  $M$ , 200 gm. (?);  $L$ , 12.2 cm.

	FIRST PRELIMINARY TREMORS.		SECOND PRELIMINARY TREMORS.		REGULAR WAVES.	MAX.	PERIOD.	AMPLITUDE.	EARTH'S AMPLITUDE.
	m.	s.	m.	a.	m.	«.	mm.	sec.	mm.
North component . . . . .	32	54	42	16	14	22	30.6	16	0.18
Interval . . . . .	20	26	29	48	61	54			

The instrument was not still when the disturbance arrived; from an examination of the photographic copy of the seismogram it seems probable that the first preliminary tremors began at  $29^h 34^m$ , giving an interval of 17 minutes 06 seconds. During the regular waves an amplitude of 4.5 mm. was reached at  $14^h 17.5^m$ , when the earth's amplitude amounted to 0.38 mm. This was the maximum earth movement. During the principal part at  $14^h 30.6^m$ , the earth-amplitude was 0.24 mm.

## KODAIKAWAL, MADRAS, USDIA.

Solar Physics Observatory. C. Michie Smith, director.

Lat.  $10^{\circ} 14' N.$ ; long.  $77^{\circ} 28' E.$ ; altitude, 2,343 meters; distance,  $127.96^{\circ}$  or 14,226 km.; chord, 11,449 km.; direction, N.  $26^{\circ} W.$

Foundation, directly on solid rock.

Seismograms, sheet No. 2.

The instrument used was a Milne horizontal pendulum, east component; photographic registration.  $T_o$ , 15 seconds;  $V$ , 6.1;  $r$ , 340 meters;  $e$ , 1.115;  $r$ , 0.0 mm.;  $M$ , 255 gm.;  $L$ , 15.6 cm.

First preliminary tremors,  $31.6^m$  (?); interval, 19.1 minutes (?). Maximum,  $28.8^m$ . Amplitude, 2.5 mm.

The position of this station has been misplaced on the map. It should be about 2 mm. from the southern point of India and equidistant from the sea, east and west.

## PERTH, WESTERN AUSTRALIA.

Astronomical Observatory. W. Ernest Cooke, M.A., F. R. A. S., government astronomer.

Lat.  $31^{\circ} 57' S.$ ; long.  $115^{\circ} 50' E.$ ; altitude, 59.5 meters; distance,  $132.37^{\circ}$  or 14,716 km.; chord, 11,656 km.; direction, S.  $78^{\circ} W.$

Foundation, sand on limestones.

Seismograms, sheet No. 2.



The instrument used was a Milne horizontal pendulum, east component; photographic registration.  $T_0$ , 15 seconds;  $V$ , 6.1;  $J$ , 340 meters;  $e$ , 1.083;  $M$ , 255 gm.;  $L$ , 15.6 cm.

Second preliminary tremors (?), 37.6<sup>m</sup>; interval, 25.1 minutes. Regular waves, 18.3<sup>m</sup>; interval, 65.8 minutes. Maximum amplitude, 2.0 mm.

A glance at the seismogram will show the difficulty of getting satisfactory determinations of the times of arrival of the first two phases. The beginning at 13<sup>h</sup> 37.6<sup>m</sup> certainly does not correspond with the beginning of the first preliminary tremors as this phase would be, for moderate and large distances, much weaker than was recorded at Perth; it is possible that this time refers to the second preliminary tremors. The times given accord with the marks on the seismogram; but in Circular 14 of the Seismological Committee of the British Association for the Advancement of Science, the corresponding times are 2.4 minutes earlier.

## CAPE OF GOOD HOPE, AFRICA.

Royal Observatory. Sir David Gill, director.

Lat. 33° 56' S.; long. 18° 29' E.; altitude, 7 meters; distance, 148.63° or 16,524 km.; chord, 12,266 km.; direction, S. 86° E.

Foundation, weathered Paleozoic rocks.

Seismograms, sheet No. 1.

The instrument used was a Milne horizontal pendulum, east component; photographic registration.  $T_0$ , 12 seconds;  $V$ , 6.1;  $J$ , 220 meters; angular displacement, 1 mm. = 0.21";  $M$ , 255 gm.;  $L$ , 15.6 cm.

	PRELIMINARY TREMORS.	REGULAR WAVES.	MAX.	AMPLITUDE.
East component . . .	<i>min.</i> 36.5?	<i>min.</i> 33.5?	<i>min.</i> 34.0	<i>mm.</i> 0.2
Interval . . . . .	24.0?	81.0?	81.5	

The record is extremely small and is not brought out in the reproduction of the seismogram. On the photographic copy of the seismogram the line shows a slight swelling beginning at 13<sup>h</sup> 36.5<sup>m</sup>, and a few long-period waves begin at 14<sup>h</sup> 33.5<sup>m</sup>. It does not appear why this record is so much smaller than those of Perth and Mauritius.

## ISLAND OF MAURITIUS.

Royal Alfred Observatory. T. F. Claxton, director.

Lat. 20° 06' S.; long. 57° 33' E.; altitude, 51 meters; distance, 162.02° or 18,012 km.; chord, 12,601 km.; direction, N. 1° W.

Seismograms, sheet No. 2.

The instrument used was a modified Milne horizontal pendulum, two components; photographic registration.

(1) North component:  $T_0$ , 20.4 seconds;  $V$ , 11;  $J$ , 1,140 meters;  $e$ , 1.042; angular displacement, 1 mm. = 0.39";  $M$ , 310± gm.;  $L$ , 15 cm. (?)

(2) East component:  $T_0$ , 20.4 seconds;  $V$ , 8;  $J$ , 830 meters;  $e$ , 1.007; angular displacement, 1 mm. = 0.25";  $M$ , 340± gm.;  $L$ , 13 cm. (?)

Preliminary tremors, 41.2<sup>m</sup> (?); interval, 28.7<sup>m</sup> (?). Regular waves, 36.3<sup>m</sup> (?); interval 83.8 minutes (?). Maximum, 50.0<sup>m</sup>. Amplitude, 5.0 mm.

Duration, 3.3 hours. The times given do not specify the component, but apparently refer to the east component, as the north seismogram is not very clear. There is a con-

siderable increase in intensity at 13<sup>h</sup> 58.3<sup>m</sup>, but it is not evident what it refers to. The time of the long waves is very doubtful.

The instrument is an ordinary Milne horizontal pendulum with the beam pointing to the east; to the supporting column a second pendulum is attached pointing south; this is about 10 cm. long and carries a weight. A long light beam carrying the diaphragm is attached at right angles to this pendulum, so that the two records are made side by side on the same photographic paper. The diaphragms are cut down to a width of 6 or 7 mm.; and the slit in the box, thru which the light passes, is closed at intervals of 2 mm., so that a series of white lines appears on the record. One of these white lines lies almost in the center of the record of the north component.

Mauritius is slightly misplaced on the map (plate 1); it should lie in the southeast angle between the lines marking 20° S. latitude and the red north-south line, thru the antipodes of the origin and practically touching these two lines.

## THE SEISIOGKAI AND ITS ELONGATION,

### EARLIER EXPLANATIONS.

On examining the seismograms, we notice that many of them can readily be divided into a number of well-defined parts. The movement begins as a slight vibration, known as the *first preliminary tremors* or the *first phase*; after an interval, dependent upon the distance of the station from the origin, there is a marked strengthening of the motion; this is called the *second preliminary tremors* or *second phase*; very soon the motion becomes quite irregular. After a second interval, also dependent upon the distance of the station, the irregularities gradually die down, giving place to waves of long period, 25 to 50 seconds, which may have a large amplitude; at many stations the largest earth-amplitudes occur during this phase. The time when these waves take on a fairly regular form can usually be identified with some accuracy and is therefore taken as the time of arrival of the *regular waves*. It is a little later than the *long waves* of Professor Omori and a little earlier than the *large waves* of Professor Milne. I have adopted this point, as I found it in general more easily identifiable, in the various seismograms, than those just mentioned; tho in some seismograms it is difficult to determine accurately where the regular waves begin. In a few cases it is not clear that there are any regular waves at all. This phase does not last long, but it is quickly followed by waves of shorter period, 15 to 20 seconds, during which the pointer is apt to record its greatest amplitude, and which has, therefore, been called the *large waves* or *principal part*; it dies down with more or less irregularity until quiet is restored. This may require several hours, tho the earthquake at the origin may have lasted less than a minute.

A number of hypotheses have been advanced to account for the increasing duration of the disturbance as the distance of the station from the origin is greater. In the first place, it is the general belief, first suggested by Prof. K. D. Oldham,<sup>1</sup> that the first preliminary tremors are due to longitudinal waves, the second preliminary tremors to transverse waves, these two being propagated thru the body of the earth; and that the long waves and principal part are due to waves transmitted along the surface; altho some seismologists think that all waves are transmitted around the earth at or near the surface. A part of the record, near its end, is, in some cases, due to surface waves which have past around the earth and have approached the station from the antipodes.

As longitudinal waves advance more rapidly than transverse the interval between them naturally increases with the distance of propagation. This is the most satisfactory explanation of the increasing interval between the two phases, but according to it we should have two groups of waves separated from each other by a period of quiet; whereas, in reality, we have a continuous disturbance; and, moreover, observation does not confirm the idea that the first and second preliminary tremors consist solely of longitudinal and transverse waves, respectively.

It has also been suggested that repeated reflections from the earth's surface would cause a succession of impulses; but in this case also they would be discontinuous. Still, it is most probable that some of the sudden strengthenings of the movement are due to the arrival of these reflected waves.

<sup>1</sup> On the Propagation of Earthquake Motion, to Great Distances. PML Trans. R. S. 1900-1901, vol. 194, pp. 135-174.

An explanation has been sought by supposing that waves of various periods are present in the disturbance and that they are propagated at various rates, just as light waves of different wave-lengths travel at different speeds in transparent substances. Altho the slow periods of the regular waves change into the quicker periods of the principal part, this change does not seem to continue during the remainder of the disturbance; nor has a similar change been discovered during the first two phases.

#### A NEW EXPLANATION.

The passage of sound thru air suggests a better analogy. A strong sound, like the firing of a cannon or a clap of thunder, is not heard at a distance as a sharp noise, but is accompanied by a rumbling that lasts for many seconds; this is due to reflections and refractions of the sound at the surfaces of many layers of air of varying temperature, etc. Now the material of the earth for a few kilometers from the surface consists of rocks of varying density and elasticity; and when an elastic wave crosses the bounding surface between two different materials, it is in general split up into four waves, reflected longitudinal and transverse waves, and refracted longitudinal and transverse waves. When the reflected waves, returning, meet a boundary between different kinds of rock, they are again reflected and send waves forward, which are, however, retarded behind the original wave. In this way, by repeated reflections and refractions, a large part of the energy of the original wave would be, as it were, stored up in the heterogeneous surface layer of the earth and be slowly given out, thus keeping up a continuous supply at the surface for a limited time.

If the whole earth were sufficiently heterogeneous, we should not have, at distant stations, the distinction between first and second preliminary tremors, for there would be thruout the whole course of the waves such frequent transformations from longitudinal to transverse waves and *vice versa*, that they would arrive at a distant station thoroly mixed, and the supply of energy there would be fairly continuous, without the sudden variation which actually marks the arrival of the second phase. But we believe that, with the exception of a surface layer a few kilometers thick, the earth is fairly homogeneous, or, rather, without sudden changes in density or elasticity; and that an earthquake will set up both longitudinal and transverse vibrations, which will travel at different speeds and become entirely separated from each other in the homogeneous interior. When the longitudinal waves reach the heterogeneous layer near the surface they will be broken up; at every refracting surface both longitudinal and transverse waves will be sent forward; as the former always travel the faster, they will arrive first at the earth's surface; but, in general, the transverse waves, set up at the last refracting surface, will not be far behind them. The proportion of longitudinal and transverse waves in the first preliminary tremors, at a given station, will probably depend upon special characteristics of the rock in the neighborhood and also on the direction from which the waves come; for transformations depend on the angle between the vibrations and the refracting surface. In regions of stratified rocks such surfaces are very numerous and are usually parallel with each other; their influence would vary in accordance with the direction in which the vibrations met them. It might thus be possible for the first preliminary tremors to consist almost wholly of longitudinal waves, or to consist of both kinds equally; but it does not seem possible that transverse waves could predominate in them.

Let us now turn our attention to the group of transverse waves traveling by themselves in the homogeneous interior of the earth. They fall farther and farther behind the longitudinal waves; when they reach the heterogeneous outer layer they also suffer transformations, giving rise to both longitudinal and transverse waves, and these, by continual

reflections and refractions, prolong the time during which this group reaches the surface. In this group, as in the first, the proportion of longitudinal and transverse vibrations reaching the surface may vary between wide limits; but the longitudinal waves can never predominate. However, the first vibrations of the group will be longitudinal; for at the first refracting surface which the waves meet longitudinal waves will, in general, be generated, and will immediately advance at a higher speed, always keeping ahead of any transverse waves that they may develop. These waves, like the leaders of the first group, are apt to be weakened by reflections and transformations and may fail of recognition when they are superposed on the later vibrations of the first group. The time of arrival of the first group is dependent on the speed of the longitudinal waves, from start to finish; but that of the second group depends on the speed of transverse waves in the homogeneous interior and of longitudinal waves in the heterogeneous outer layer.

We do not know enough about the interior of the earth to fix the thickness of the outer heterogeneous layer, nor to say whether severe earthquakes originate in it or below it; tho the former seems the more probable. We have for simplicity of statement assumed the latter, but this is by no means necessary. If the earthquake originated in the heterogeneous layer, both groups of waves would suffer some elongation before they reached the homogeneous interior and after they left it; but they would travel without change so long as they were in it. If there is a central metallic core in the earth, changes would, of course, take place when the waves cross its boundary.

#### THE STRONGER TRANSVERSE WAVES.

If the outer layer of the earth were sufficiently thick or sufficiently heterogeneous, longitudinal and transverse vibrations of the preliminary tremors might become so mixed in it that the first and second phases would not be distinguishable; but nevertheless, the two kinds of waves would separate from each other in the homogeneous interior and at distant stations the two phases would appear. But the fact that the second phase is so much stronger than the first at all stations, including those  $30^\circ$  or  $40^\circ$  from the origin, which are too near for the difference to be accounted for by the vertical component of the longitudinal motion, indicates that the outer homogeneous layer by no means destroys the distinction between longitudinal and transverse waves in the first two phases; and that the transverse waves are originally much stronger than the longitudinal. This may be due to the way in which the waves originate at the fault-surface. When the rupture occurs there, the friction of one side against the other is probably the chief means of starting the vibrations, and evidently would produce stronger transverse than longitudinal waves.

#### THE SEPARATION OF THE FIRST TWO PHASES.

The distinction of the first two phases would exist from the very start, but they would naturally reach a near station only a few seconds apart; and if the original shock lasted longer than this interval and underwent considerable variations in intensity, the arrival of the first preliminary tremors, due to successive parts of the shock, might mask the arrival of the second. Moreover, and this fact is perhaps still more important, few instruments are provided with very open time-scales, a necessary condition to show the separation of the phases near the origin. Fortunately the Ewing three-component seismograph at Mount Hamilton met this requirement; its time-scale was 6 or 7 mm. to the second and it was therefore quite competent to show the interval of 9 seconds which separated the beginnings of the first two phases. Mount Hamilton, at a distance of 128 km. from the origin, was the nearest station provided with a time-marking record. At Victoria (distant  $10.41^\circ$  or 1,156 km.) the smallness of the time-scale and the overlapping

of vibrations from various parts of the fault-plane make it impossible to recognize the second phase; but at Sitka ( $20.72^\circ$  or 2,302 km.), and at more distant stations, the second phase is distinct. So far, therefore, as the observations of the California earthquake are concerned, there is no reason to believe that the first two phases are not distinct from their starting-point; and the reason this has not been recognized heretofore may be entirely due to the small time-scale of the instruments.

#### THE DIRECTION OF MOTION.

Let us see how far the observed directions of motion support the above explanation of the elongation of the first two phases. The duplex seismographs of Berkeley and Mount Hamilton indicate the direction of the beginning of the motion; they show that the first movement of the ground at these stations was directed away from the origin. The extent of the fault-surface soon caused waves to come from many directions, so that the recorded movement became confused almost immediately; but at Mount Hamilton there were two longitudinal vibrations before other waves materially interfered with their direction. The seismogram of the three-component Ewing instrument shows, when we consider the arrangement of the recording pens, that the first and second preliminary tremors began there with a movement southeast and northwest, that is, along the direction of propagation. These two were the only stations near the earthquake's origin which yielded definite information regarding the direction of motion at the beginning of the shock. And of all the records at distant observatories there are comparatively few which throw light on this subject; because only a very few instruments were so oriented as to record separately the vibrations parallel with, and at right angles to, the course of the waves. The stations in the eastern part of the United States were well situated for this purpose, as the waves were moving almost directly eastward when they past them. Ottawa and Cheltenham each recorded the longitudinal waves (east component) about 13 seconds before the transverse, and the longitudinal waves also were somewhat stronger during the first preliminary tremors. In the second group, transverse waves (north component) were recorded at Cheltenham 9 seconds earlier than the longitudinal; and they seem very slightly stronger. The northern component of the second group in the Ottawa seismogram overlaps other parts and can not be clearly read; but it seems to be somewhat stronger than the eastern component. The Albany record does not yield definite results, and the other stations in this neighborhood only recorded one component of the motion.

The waves arrived at the majority of the European observatories in a direction making angles between  $30^\circ$  and  $40^\circ$  with the meridian; and as by far the larger number of the instruments recorded either north-south or east-west motion, they would be affected about equally and would not distinguish between longitudinal and transverse waves. A few instruments, however, were oriented so as to make the distinction. The triple Ehlert instrument at Uccle began to record at the same moment with all three components, but the longitudinal waves (N.  $60^\circ$  W.) were stronger during the first preliminary tremors, and the transverse (N.  $60^\circ$  E.) during the second preliminary tremors. At Kremsmünster the longitudinal waves (distributed between the two components, N.  $13^\circ$  W. and N.  $73^\circ$  W.) seem stronger during the first preliminary tremors, and the transverse (N.  $47^\circ$  E.) during the second preliminary tremors. At Rocca di Papa the longitudinal vibrations (NW.) in the second preliminary tremors were registered 42 seconds before the transverse (NE.), according to Professor Agamennone's reading of the original record. At Messina, the transverse (NE.) vibrations in the second preliminary tremors were somewhat stronger than the longitudinal.

The waves approach Taschkent and Jurjew making a small angle with the meridian. No difference can be made out for the two components during the first and second preliminary tremors at Taschkent, but at Jurjew the east-west component was larger for both. The waves approach Mauritius exactly from the north; and it is the most distant station from the origin ( $162^\circ$ ). The earlier part of the motion was distinctly stronger on the north-south component; and this preponderancy lasted during the first part of the second preliminary tremors; but it must be remembered that the time of beginning of this phase is somewhat doubtful. On the other hand, we find the east-west motion, at Tacubaya, stronger for the first two phases, altho the direction of propagation was practically symmetrical with respect to the two components. At Upsala the east-west movement was slightly more marked during the first preliminary tremors and the north-south during the second preliminary tremors, tho the opposite would have been expected. At Potsdam, Jena, and Göttingen the north-south movement was slightly the stronger during the second preliminary tremors, also contrary to expectation.

This is the very meager evidence which the records of the earthquake offer regarding the direction of motion during the preliminary tremors. It is not entirely consistent, but it indicates on the whole that longitudinal vibrations were preponderant during the first preliminary tremors, and transverse during the second preliminary tremors; but that both kinds of motion existed practically during the whole of the preliminary tremors; and therefore the evidence can be said to favor the theory advanced to explain the drawing out of the record.<sup>1</sup>

We must remember that transverse vibrations may have any direction around the direction of propagation, and in particular may lie in the vertical plane thru this direction; the horizontal projection of their motion would then lie in the direction of propagation of the disturbance along the surface, and they would be recorded as tho they were longitudinal waves. This may explain the longitudinal direction of the strong motion at Mount Hamilton, tho the movement on the fault-plane would lead us to expect transverse waves more nearly in a horizontal plane.

#### THE PRINCIPAL PART AND THE TAIL.

It is generally believed that the surface waves are also drawn out more and more as the distance of the station is greater; but an examination of the seismograms of the California earthquake does not support this view. It is very difficult to determine what should be considered the principal part and what the tail portion of the seismogram; but on making the best estimate we can of the principal part, we find no regularity in its duration; and we also find very different results according to the type of instrument recording. For instance, at Taschkent, one would estimate about 2.5 hours for the principal part from the Repsold-Zöllner instrument, and 15 minutes from the Bosch-Omori. At Baltimore (distant  $35.7^\circ$ ) a Milne pendulum makes the duration of the principal part about 47 minutes; whereas Bosch-Omori instruments at Washington ( $35.4^\circ$ ) and Cheltenham ( $35.6^\circ$ ) indicate a duration of only 6 to 8 minutes. At San Fernando ( $85.25^\circ$ ) a Milne pendulum gives a duration of 45 minutes; at Krakau ( $85.98^\circ$ ) a Bosch-Omori, subject to some solid friction, gives 5 minutes; and at Vienna ( $86.37^\circ$ ) a Wiechert inverted pendulum gives 13 minutes. The following table, in which the duration of the principal part is given in minutes, is made up from the records of Milne pendulums alone, and shows that even the same type of instrument does not yield consistent results.

<sup>1</sup> Prof. C. F. Marvin (Monthly Weather Review, 1907, vol. xxxv, p. 5) obtained very interesting results regarding the direction of vibration at Washington at the time of the Jamaican earthquake, January 14, 1907. The longitudinal vibrations began earlier and were much the stronger during the preliminary tremors; the transverse vibrations were much the stronger during the principal part.

TABLE 6.—Duration of the Principal Part as Recorded by Milne Instruments.

STATION.	DISTANCE.	DURATION.	STATION.	DISTANCE.	DURATION.
Victoria . . .	10.4	49	Kew. . . . .	77.6	25 or 36
Toronto . . .	32.9	32	Irkutsk . . . . .	80.8	28 or 60
Honolulu . . .	34.6	62	Coimbra . . . . .	81.4	24
Baltimore . . .	35.7	47	San Fernando. . . . .	85.3	54
Paisley . . .	72.6	29	Calcutta . . . . .	112.7	31
Edinburgh . . .	73.0	35	Bombay . . . . .	121.2	26
Bidston . . .	74.8	36	Perth . . . . .	132.4	60

It is quite evident that no conclusion regarding the variation in duration of the principal part at different distances from the origin can be drawn from such data.

But, altho we may be unable to recognize a progressive change in the duration of the principal part, nevertheless it is quite certain that all seismographs register a strong motion lasting much longer than the original shock. What has been called the *violent shock*, and which alone could have affected distant seismographs, did not last more than 40 or 50 seconds; whereas the recorded principal part certainly lasted many minutes and in some cases an hour. This may be in part due to the synchronism of the periods of the waves and the instruments, but it can not be entirely explained in this way and it must be lookt upon as not yet understood.

We have a little information regarding the prevalent direction of motion during the principal part. At Ottawa, Cheltenham, and Albany the longitudinal waves retained their intensity for a longer time than the transverse, tho we can not say which attained the greater maximum. At Rocca di Papa the longitudinal waves attained the greater maximum, but the durations of the two were about the same. At Messina the longitudinal waves were stronger and lasted longer than the transverse. On the other hand, the transverse waves lasted longer at Florence, and they had a greater maximum at Cagliano. The observations are very meager and very inconsistent; evidently more careful observations must be made to show to what extent the longitudinal and transverse waves are characteristic of different parts of the seismogram, how far this quality is different at different stations, to what variations it is subject, and what are their causes.

The long tail portion of the seismogram is still a riddle; and altho we can hardly help considering it as in some way due to waves following different paths and to reflections, we shall see further on (page 124) that simple reflections will not explain it. One may easily be misled in attempting to correlate certain movements on different seismograms; for instance, the last marked broadening of the trace of the Paisley, Edinburgh, and Bidston seismograms (sheet No. 1), occurring a few minutes before 14<sup>h</sup> 30<sup>m</sup>, is so similar that one would naturally suppose that they represent a special group of progressive waves; on determining the times of occurrence we find for its maximum, 14<sup>h</sup> 14.7<sup>m</sup>, 14<sup>h</sup> 20<sup>m</sup> and 14<sup>h</sup> 26.1<sup>m</sup> at the three stations respectively; the difference in time at Paisley and Bidston is 11.7 minutes and the difference in distance 252 km.; therefore the velocity of propagation would be 22 km./min. But the time for them to reach Paisley from the focus, a distance of 8,060 km. would be 62.2 minutes, requiring a velocity of 130 km./min. These values are so different that we must regard this broadening of the trace as due to some accidental synchronism of periods at the three stations, and not to an objective characteristic of the disturbance itself. There are many difficulties in understanding the characteristics of the seismogram which have not been overcome; and it is not likely that we shall have a complete explanation of it until a large number of heavily damped seismographs are installed, whose records will correspond closely with the actual movements of the earth, and will not be materially affected by the peculiarities of the instrument itself.





THE PROPAGATION OF THE DISTURBANCE.

THE HODOGRAPHS

All the available data which has been obtained bearing on the velocity of transmission has been collected in table 7 and exhibited graphically in plate 2. It will be seen that by far the larger number of observations occurred at distances between 70° and 100° from the origin. Many of the stations are at so nearly equal distances that they have been grouped together and entered as a single observation in the plate; therefore the number of observations marked on the plate is considerably less than the number actually represented. All the seismograms have not the same degree of accuracy, and different symbols have been used to indicate these differences; the observations from some stations are less reliable on account of the difficulty in reading the seismogram; in some cases, less confidence can be given to the record because the seismogram was not at hand to confirm it; this applies with special force to the observations of the regular waves, for there is no general consensus of opinion as to the particular point of the seismogram that indicates their beginning. The curves drawn in the plate show the times taken for the three phases to travel from the origin to the distance of the observing station, these distances being indicated in degrees and kilometers. The stations are marked at the bottom, singly or in groups; occasionally some stations of a group fail to yield satisfactory determinations of the time of arrival of a phase of the disturbance; this phase is then marked with the initials of the stations which recorded it.

TABLE 7.— Times of Transmission of the Various Phases.  
 [1 P. T. = First preliminary tremors.] [2 P. T. = Second preliminary tremors.]  
 [R. W. = Regular-waves.] [3 P. = Principal part.]

STATION.	ARC.		CHORD.	TIME INTERVAL, IN MINUTES AND SECONDS.			
				1P. T.	2P. T.	R. W.	P. P.
				m. #.	m. s.	m. s.	m. s.
Mount Hamilton	1.16	128	129	0 17	0	....	....
Victoria	10.41	1157	1156	0 14	... m	....	....
Sitka	20.72	2303	2291	4 34	8 38	10 04	....
Tacubaya	27.70	3081	3050	5 30	10 24	13 09	13 37
Toronto	32.93	3571	3610	6 48	12 00	15 24	....
Honolulu	34.60	3846	3790	7 00	11 54?	....	....
Ottawa	35.38	3932	3871	6 51	12 2?	....	18 30
Washington	35.44	3939	3878	6 52	12 32	16 52	18 00
Cheltenham	35.64	3962	3899	6 55	12 37	17 48	20 00
Baltimore	35.74	3973	3909	6 54	12 42	....	19 06
Average	35.55	3952	3889	6 53	12 33	17 20	18 54
Albany	37.13	4128	4056	9 02	16 04	20 17	21 12
Porto Rico	53.45	5942	5729	9 22	17 39	....	....
Trinidad	60.94	6774	6460	....	....	29 30	....
Apia	69.20	7694	7235	10 54	19 56	....	....
Mizusawa	70.46	7834	7349	11 39	20 46	....	....
Ponta Delgada	72.53	8064	7536	11 00	....	....	38 00
Paisley	72.54	8065	7537	10 42	20 48	34 54	38 30
Bergen	72.79	8092	7560	10 23	19 47	....	39 16
Edinburgh	72.99	8115	7578	11 00	20 30	35 30	39 30
Average	72.71	8079	7553	10 48	20 22	35 12	38 48
Tokyo	73.92	8217	7660	12 07	21 56	33 52	37 47
Bidston	74.81	8317	7739	11 48	21 30	35 42	39 06
Average	74.37	8267	7700	11 58	21 43	34 47	38 28
Upsala	76.80	8538	7914	12 23	22 16	37 52	40 34
Shide	77.08	8569	7938	11 48	21 44	38 08	....
Osaka	77.30	8594	7957	11 56	21 45	35 28	....
Kobe	77.54	8619	7976	11 55	21 51	37 52	....
Kew.	77.63	8610	7986	....	21 30	37 30	....
Average	77.27	8540	7954	12 00	21 49	37 22	....

TABLE 7.—Times of Transmission of the Various Phases.—Continued.

STATION.	ARC.		CHORD.	TIME INTERVAL, IN MINUTES AND SECONDS.			
				IP. T.	2P. T.	R. W.	P. P.
				m. s.	m. s.	m. s.	m. s.
Hamburg	79.74	8866	8167	12 04	22 22	39 17	....
Uccle	79.80	8872	8173	11 59	22 29	....	....
Jurjew	80.27	8924	8212	12 15	22 18	....	....
Irkutsk	80.82	8986	8259	12 08	22 22	38 48	....
Average	80.16	8912	8203	12 06	22 23	39 02	....
Potsdam	81.35	9042	8303	12 22	22 55	39 21	42 22
Göttingen	81.36	9046	8304	12 16	22 38	38 37	44 08
Coimbra	81.39	9049	8307	12 54	22 30	38 00	....
Average	81.37	9046	8305	12 31	22 47	38 39	43 15
Leipzig	82.40	9161	8392	12 22	23 11	38 53	43 02
Jena	82.45	9167	8396	12 06	22 41	38 44	44 11
Strassburg	82.91	9218	8434	12 29	22 52	....	....
Average	82.59	9182	8407	12 19	22 55	38 48	43 36
Munich	84.75	9423	8587	12 32	23 06	39 15	....
San Fernando	85.25	9478	8628	12 36	22 48	....	....
Average	85.00	9451	8541	12 34	22 57	39 15	....
Tortosa	85.65	9522	8660	12 27	23 32	42 32	....
Kremsmünster	85.77	9535	8670	11 54	23 00	....	....
Krakau	85.98	9558	8687	....	23 14	41" 38	45 07
Granada	86.08	9570	8696	12 12	22 52	42 11	....
Pavia	86.20	9583	8707	12 28	22 38	41 32	48 27
Vienna	86.37	9602	8719	12 47	23 40	41 18	45 05
Average	86.01	9562	8690	12 18	23 09	41 50	....
Laibaeh	87.22	9697	8786	13 06	23 02	41 42	....
Triest	87.74	9754	8828	12 41	23 08	....	....
O'Gyalla	88.08	9792	8856	12 52	23 40	....	....
Florence (Ximeniano)	88.23	9808	8868	13 57	24 36	....	....
Zagreb	88.33	9820	8876	12 57	23 03	40 48	....
Pola	88.34	9821	8877	13 28	23 45	41 46	....
Quarto-Castello	88.40	9828	8882	14 10	24 36	39 33	....
Zi-ka-wei	88.49	9838	8889	12 56	23 08	43 32	....
Pilar	88.75	9866	8909	13 06	....	....	....
Average	88.17	9803	8864	13 17	23 37	40 57?	....
Rocca di Papa	90.48	10061	9046	....	24 02	45 02	....
Belgrade	90.67	10080	9061	....	24 26	....	....
Average	90.58	10070	9054	....	24 14	45 02	....
fsehia	91.84	10210	9152	14 14	24 30	43 56	....
Caggiano	92.63	10297	9213	....	24 12	44 18	....
Taihoku	92.75	10311	9222	16 24?	..	43 52	....
Sofia	93.58	10404	9286	12 32?	23 " 17?	44 38	....
Messina	94.67	10524	9368	....	..	43 00?	....
Catania	95.04	10567	9396	13' 37	23 " 57?	44 38	53 20?
Wellington	97.62	10853	9588	14 06	24 18	49 42?	....
Calamate	98.28	10927	9636	....	....	49 38	....
Tiflis	99.43	11054	9719	13 41	25 31	....	....
Taschkent	99.86	11102	9750	14 00	24 54	....	....
Average	99.65	11078	9735	13" 50?	24 12?	....	....
Christchurch	100.40	11162	9790	....	21 06	48 30	....
Manila	100.46	11189	9793	10 16?	....	48 30?	....
Average	100.43	11165	9790	10 16?	21 " 00"	48 30?	....
Tadoteu	100.00	11262	9852	12 39?	....	....	....
Cairo	107.92	11998	10302	18 30	26 30?	....	....
Calcutta	112.72	12531	10607	16 42?	20 54	53 06	....
Bombay	121.19	13472	11099	....	28 IS	59 IS	....
Katavia	124.99	13897	11300	26' 26?	29 48	61 54	....
Kodaikanal	127.90	14226	11449	19 00?	....	....	....
Perth	132.37	14716	11655	....	25 06?	65 48	....
Cape of Good Hope	148.63	16524	12256	24 00?	....	81 00?	....
Mauritius	102.02	18012	12601	....	28' 42?	83 48	....

After plotting in the times of arrival of the three phases at the various stations a smooth curve is drawn thru the points marked, so that the errors of the observations may be as small as possible; the velocity of the first preliminary tremors, as noted on page 7, is assumed to be 7.2 km./sec. near the origin; the velocity of the second preliminary tremors in the same region becomes 4.8 km./sec. from the Mount Hamilton observations, as they begin there 9 seconds after the first preliminary tremors. A special method was followed in drawing the straight line for the long waves and it will be given further on. These curves are called "hodographs." The average velocity of transmission to any station is evidently given by the time interval divided by the distance; that is, it would equal the tangent of the angle which a straight line, drawn from the origin to a point on the hodograph immediately above the station, makes with the vertical; and the velocity along the surface would be given by the difference between the times of arrival at two stations divided by the difference of their distances from the origin, provided these distances differed but little from each other.

#### THE PRELIMINARY TREMORS.

The first thing that strikes us on examining the plate is that the hodographs of the first two phases are curved, indicating that the average velocity of transmission increases with the distance; and that the hodograph of the regular waves is straight, showing a constant velocity independent of the distance. These distances have been measured along the surface, or, as it is expressed, along the arc. When we plot the hodographs of the first two phases in terms of the distance of the stations from the origin, measured by the shortest route, that is, by the chord, as shown in the upper part of the plate, we find them still curved, but much less so than in the former case. It is the general belief that the curvature of these lines indicates that the waves travel thru the body of the earth and that their velocity increases with the depth of the path below the surface; if this be true, and no satisfactory arguments have been advanced against it, the waves would not follow the shortest path to a station, that is the chord, but would follow a curved path, convex downward, which would bring them to the station in the shortest time. Unfortunately at distances greater than  $100^\circ$  for the first preliminary tremors and  $125^\circ$  for the second preliminary tremors, the observations of the phases become extremely doubtful; and it is precisely the paths leading to stations beyond these distances that dip very deep towards the center of the earth, and that might reveal the nature of that region.

The cause of the inaccuracy of observations at great distances is not far to seek. The first preliminary tremors are always very weak and are recorded as very small vibrations even at comparatively small distances. If, moreover, as we have given reasons to believe, their vibrations are longitudinal, a large part of their energy would be taken up in vertical vibrations at the surface, particularly at great distances, and would therefore fail to produce an appreciable disturbance of instruments recording horizontal movements only. The horizontal and vertical components of the first preliminary tremors at Göttingen (distant  $81.36^\circ$ ) have about the same amplitude, which is very small; and this shows that the weakness of this phase is not merely due to its tendency to produce vertical vibrations at the earth's surface. Moreover, the amplitude of vibrations would decrease more rapidly than the distance, because, as Prof. C. G. Knott\* has shown, the curved paths of these waves would cause the energy to be concentrated upon the nearer stations, with a corresponding diminution at the more distant ones. It also happens that all the instruments at stations beyond  $100^\circ$  have a low magnifying power, with the exception of Batavia; and even then; the magnifying power, 05.5, may be insufficient to indicate the real beginning of the first preliminary tremors. It is quite possible that the beginning of the record at Mauritius may represent the second preliminary tremors, and that the

\* The Physics of Earthquake Phenomena, p. 253.

hodograph should pass exactly thru the records of Calcutta and Mauritius; but this is too uncertain to justify the extension of the hodograph to Mauritius. It does not seem to be possible, from the observations of this earthquake, to draw any certain inference regarding the velocity of propagation of the first two phases much beyond  $110^\circ$ .

The beginning of the second preliminary tremors is often the most easily recognizable point of the seismogram. The first preliminary tremors frequently have so small an amplitude that their beginning can not be determined; and sometimes there is no evidence of any movement until the second preliminary tremors arrive. The latter usually show themselves by a definite and well-marked increase in the amplitude of the recording instrument.

The records of the Kingston earthquake of January 14, 1907, offer a very instructive example of the influence of the magnifying power of seismographs on the times recorded. Washington, with a magnifying power of 25, recorded the first preliminary tremors; Cheltenham, with a magnifying power of 10, began its record with the second preliminary tremors; whereas Baltimore, with a magnifying power of 6, only recorded the principal part. These three stations are close together and practically at the same distance from Kingston.

The hodograph of the second preliminary tremors, expressed in terms of the distance measured along the chord, shows a point of inflection at a distance of about 9,000 km.; this does not indicate that the average velocity diminishes at this distance, but merely that it does not increase as rapidly as it does at shorter distances; this part of the curve, however, is quite doubtful and we are not justified in drawing any very definite conclusion from its form. It is extremely disappointing that the observations of this earthquake do not lead to definite results regarding the propagation of the disturbance to very great distances; for the point where the earthquake occurred and the time of its occurrences are both known to a satisfactory degree of accuracy<sup>1</sup> and instruments recorded the shock at stations as far as  $162^\circ$  distant, that is, very nearly to the antipodes. This further emphasizes the importance of installing instruments recording the vertical component of motion, and instruments with high magnifying powers, not less than 100; for they alone can be expected to yield satisfactory records of the times of the arrival of the various phases of very distant earthquakes, regarding which our information is still very vague.

As the earthquake originated at some distance below the surface, the surface velocity in the immediate neighborhood of the epicentrum would be very large; it would diminish rapidly as the distance increased, would reach a minimum and again increase as the paths of the waves to the more distant stations extended deeper into the earth. If we had absolutely accurate observations, the hodograph, drawn from them, would be concave upwards near the origin, would pass thru a point of inflection a little further off, and would then pass into the general form, concave downwards, as drawn in the plate. Seebach<sup>2</sup> first pointed out that the form of the curve in the neighborhood of the origin could be used to determine the depth of the focus; he assumed constant velocity in all upward directions near the origin; Prof. A. Schmidt,<sup>3</sup> assuming increasing velocity with the depth, modified the results; but the degree of accuracy required of the observations is so great that all attempts so far made to determine the depth of the focus by this means are unreliable; and we can not expect to apply the method successfully until the accuracy of our observations is far greater than it is now. Table 8 shows the distances of stations from the centrum in kilometers, in terms of their distances from the epicentrum measured along the surface of the earth, and of the depth of the centrum; these distances take into account the curvature of the earth and are accurate to a fraction of a kilometer.

<sup>1</sup> Das Mitteldeutsche Erdbeben von 6 Mars 1872. Leipzig, 1873.  
<sup>2</sup> Wdlenbewegung und Erdbeben. Jahreshfte far Vaterlands Naturkunde in Wtirtemberg, 1888, p. 248.

Table 9 shows the differences in the time of arrival in seconds, of the first preliminary tremors at stations at various distances, when the focus is at the given depth or at the surface, calculated under the supposition that the velocity is 7.2 km./sec. Table 10 gives similar results for the second preliminary tremors, whose velocity is taken at 4.8 km./sec. (see p. 117). In these tables  $z$  is the depth of the focus and  $D$  the distance of the station from the epicentrum measured along the earth's surface, in kilometers.

TABLE 8. — Distances from the Centrum (in kilometers).

$D \setminus z$	10	20	50	100	200	400
0	10.0	20.0	50.0	100.0	200.0	400.0
10	14.1	22.3	51.0	100.5	200.2	399.8
20	22.3	28.3	53.8	101.9	200.8	399.9
50	51.0	53.8	70.6	111.5	205.5	401.5
100	100.5	101.9	111.6	141.3	222.3	409.3

TABLE 9. — Differences between the Times of Arrival of the First Preliminary Tremors when the Focus is at the Surface or at the Depth  $z$  (in seconds).

$D \setminus z$	10	20	50	100	200	400
10	0.6	0.2	0.1	0.0	0.0	0.0
20	1.6	1.2	0.5	0.3	0.1	0.0
50	5.7	4.7	2.9	1.6	0.8	0.2
100	12.6	11.4	8.6	5.7	3.1	1.3

TABLE 10. — Differences between the Times of Arrival of the Second Preliminary Tremors when the Focus is at the Surface or at Depth  $z$  (in seconds).

$D \setminus z$	10	20	50	100	200	400
10	0.9	0.5	0.2	0.0	0.0	0.0
20	2.6	1.7	0.8	0.4	0.2	0.0
50	8.5	7.0	4.3	2.4	1.1	0.3
100	18.9	17.0	12.8	8.6	4.6	1.9

A glance at these tables will show that, for any probable depth of focus, stations at a distance from the origin of two or three times this depth would be wholly incapable of supplying time records which could be used in determining the depth. Let us take an example. Suppose the focus of an earthquake was at a depth of 50 km., and that it was recorded at two stations, one 50 km. and the second 100 km. distant from the epicenter; the first would record it 2.9 seconds and the second 1.6 seconds later than if the earthquake had occurred at the same time at the surface. The difference of these numbers, namely, 1.3 seconds, is the difference in the interval between the recorded times at the two stations, for earthquakes at a depth of 50 km. and at the surface. It would be quite impossible to determine so small a difference with any instruments now in use, and therefore such observations could only tell us that the depth was probably not much greater than 50 km. But an accurate record at a station, say, 200 km. distant from the origin might be used in connection with the records of nearer stations, to show that the focus was not very deep. In our determination of the location of the focus of the California earthquake we had observations of four stations, and by the method of least squares we found its most probable location. The observations at Ukiah and Mount Hamilton had no practical influence in determining the depth, but helped to locate the epicenter; whereas the observations at the nearer stations determined the approximate depth.

The actual points of inflection of the hodographs are not so very near the epicenter, their distances being 252, 357, 463, and 796 km. for the depths of focus 10, 20, 50, and

100 km., respectively; but the curvature of the lines practically disappears at distances from the epicenter equal to twice the depth of the focus.

Professor Rizzo has made strong inflections in his hodograph of two Calabrian earthquakes.<sup>1</sup> A straight line would fit the observations of the first preliminary tremors in the first earthquake to distances of 2,000 km. rather better than his curves, especially for the near stations; and the observations which bend the hodograph of the first preliminary tremors in the second earthquake are far too inaccurate to justify the curve. The observations of the second preliminary tremors in both cases are too few to be decisive. Moreover, the points of inflections of the curves are at a distance of about 800 km., which would correspond to a depth of focus of about 100 km.; whereas Professor Rizzo does not think the depth in either case greater than 50 km.

The curvature of the hodographs near the origin has not been shown in plate 2 because the scale is too small. The times given by the curves are measured from the time the earthquake occurred, as nearly as this could be determined, and not from the time the disturbance reached the surface at the epicenter, as has usually been done. There are certain objections to the usual method; the disturbance does not pass from the focus directly to the surface and then along the surface to distant points, but it goes directly to the distant points, and its time of arrival there, even at such short distances as four times the depth of the focus, is not materially affected by this depth, tho the time of arrival at the surface is. It is better, therefore, for our base-line to represent the time of occurrence of the shock at the focus; and if the scale of the drawing is sufficiently large to show the upward curvature of the hodograph, the curve would not pass thru the origin but above it, at a distance representing the time necessary for the shock to go from the focus to the surface. This will be only a few seconds; perhaps never more than 7 seconds for the first preliminary tremors and 10 seconds for the second preliminary tremors, as these intervals would correspond to a depth of focus of 50 km.

In table 11 are shown the velocities of the first preliminary tremors and second preliminary tremors in kilometers per second, measured along the chord. The velocities are not calculated from actual observations at the stations, but from the hodographs.

TABLE 11.—*Velocities of First and Second Preliminary Tremors in Kilometers per Second along the Chord.*

DISTANCE.			FIRST PRELIMINARY TREMORS.		SECOND PRELIMINARY TREMORS.	
Degrees.	Arc.	Chord.	Interval.	Velocity, chord.	Interval.	Velocity, chord.
°	km.	km.	min.		min.	
0	0	0	0.0	7.2	0.0	4.8
10	1112	1110	2.4	7.7	3.85	4.8
20	2224	2212	4.3	8.6	7.6	4.9
30	3335	3297	6.1	9.0	10.9	5.0
40	4447	4357	7.7	9.4	13.8	5.3
50	5559	5384	9.0	10.0	16.3	5.5
60	6671	6370	10.2	10.4	18.6	5.7
70	7783	7307	11.35	10.7	20.6	5.9
80	8894	8189	12.3	11.1	22.25	6.1
90	10006	9009	13.25	11.3	24.0	6.2
100	11118	9759	14.2	11.4	(25.7	6.3
					125.4	6.4
110	12230	10436	14.9	11.7	j 27.2?	6.4?
					126.5?	6.6?
120	13342	11033	....	....	128.5?	6.5?
					127.3?	6.7?
130	14453	11546	....	....	f 29.8?	6.5?
					l 27.8?	6.9?

<sup>1</sup> Sulla Velocity di Propagazione della Onde Sismiche, Acad. R. d. Scienze di Torino, 1905-06, vol. Lvir, pp. 309-350; Nuovo Contributo allo Studio della Propagazione dei Movimenti Sismici, same, 1907-08, vol. LIX, pp. 375-419.

Two sets of values of the second preliminary tremors are given for distances of  $100^\circ$  or more; they correspond to the two curves drawn in plate 2. The first set are more in accord with the observation at Batavia, the second with that at Mauritius; but both are very doubtful beyond about  $110^\circ$ , where they do not differ much.

## THE PATHS OF THE WAVES THRU THE EARTH.

The velocities given show the average values between the focus and the distance indicated; but they do not show the actual velocity at any point of the path. The average velocity increases with the distance of the station; and this must be due to

increasing velocity with greater depth below the surface. With such increasing velocities it is impossible for the rays to follow straight lines, but they must follow paths which are concave upwards. Prof. E. Wiechert<sup>1</sup> has given a method for following out the paths of the waves, which is dependent upon the direction of the wave as it approaches a station. The angle at the station between this direction and the surface is the angle of emergence,  $e$ , and its complement is the angle of incidence,  $i$  (see fig. 27). This angle may be found immediately if we know the velocity of the wave near the surface and the surface velocity. The former is about 7.2 km./sec.; the latter can be determined from the hodograph; it equals the angle made with the vertical by the tangent line to the hodograph. The value of the surface velocity depends, therefore, upon the actual direction of the hodograph line (plate 2), and can only be determined accurately provided the

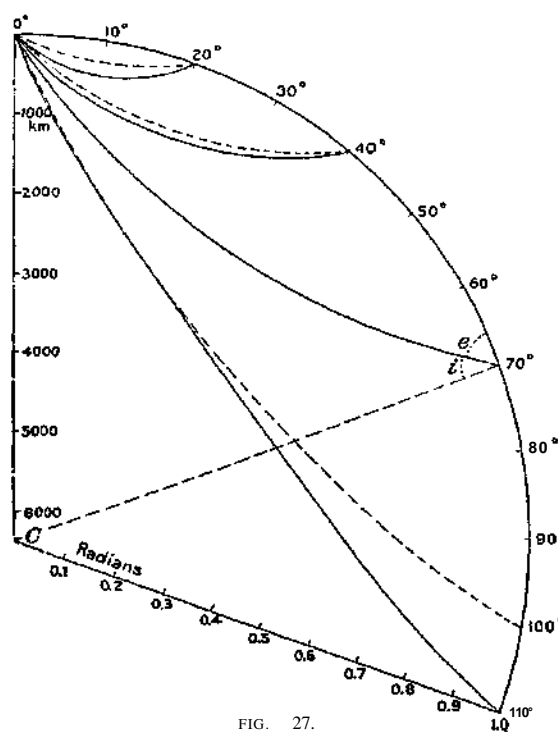

FIG. 27.

hodograph is accurate. This, however, is by no means true, so that our values for the surface velocity are only approximately correct. The paths of the waves depend upon the angles of emergence, and as they are only approximate the same is true of the paths. They, however, represent fairly well the course of the waves as they travel thru the earth to stations at various distances. Following Professor Wiechert's method these paths have been drawn in fig. 27, the full lines representing the first preliminary tremors and the broken lines the second preliminary tremors. The paths have been drawn for the first preliminary tremors leading to distances up to  $110^\circ$  and for the second preliminary tremors to  $100^\circ$ ; these are the limiting distances to which our hodographs yield fairly good values.

It will be seen that the paths have a very marked curvature, especially those leading to stations which are not very distant. The paths leading to points less than  $70^\circ$  distant are less curved for the second preliminary tremors than for the first preliminary tremors; but the opposite is true for paths leading to greater distances. The paths of both groups leading to this particular distance are practically coincident. As the waves penetrate deeper into the earth their paths become less curved; and the path leading to the antijvodes thru the earth's center would be a straight line.

<sup>1</sup> tidier Erdbebenwden. Nach. d. K. Gesells. d. Wissens. zu Göttingen, Math.-phys. Kl., 1907.



## RELATION OF THE VELOCITY TO THE DEPTH BELOW THE EARTH'S SURFACE.

Professor Wiechert's method enables us to determine the velocities at different depths below the surface. For any point on a given path we have

$$\frac{r \sin i}{v} = \frac{\bar{r} \sin \bar{i}}{\bar{v}}$$

where  $r$  is the distance from the center of the earth,  $i$  the angle which the path makes with the radius, and  $v$  the velocity; the letters in the second member refer to the same quantities at the point where the path comes to the surface.

TABLE 12.—Surface Velocities and Angles of Emergence.

FIRST PRELIMINARY TREMORS.			SECOND PRELIMINARY TREMORS.		
Distance.	Surface velocity.	$e$	Distance.	Surface velocity.	$e$
	Km. sec.	° /		Km. sec.	° /
0	3.9	0 00	0	2.6	0 00
20	5.5	44 51	20	2.95	28 06
40	6.9	55 19	40	3.75	46 22
70	9.4	65 46	70	5.45	61 42
110	13.1	72 40	100	7.5	69 51

In table 12 we have collected together the values for the surface velocities and for the angle of emergence  $e$ , for points at several distances from the origin; and from these data we can calculate the velocity at the points where the respective waves reach their greatest

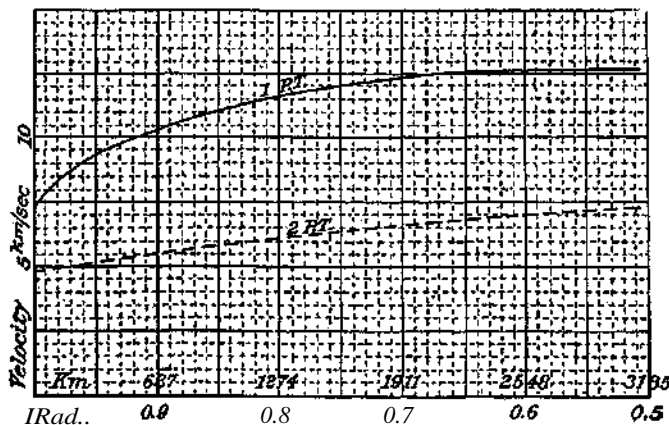

FIG. 28.

depths. At these points the paths are at right angles to the radius and  $\sin i$  is 1. The value of  $r$  can be measured in fig. 27 and the value of  $v$  determined. This process was carried out and the values of  $v$  given in table 13 were found. These values were plotted on section paper and a smooth curve drawn thru them representing the velocity as a function of the depth. On applying these velocities to the various parts of each path it was found that the time the wave would take to traverse the path did not correspond exactly with the time given by the hodograph. The velocities were slightly altered and, by the method of trial and error, new values were found which would make the time intervals correspond to those given by the hodographs. The changes in the velocities were small. These velocities are shown in table 13 in the column headed  $u$ , and graphically in fig. 28. The velocity increases with the depth below the surface, but more and more slowly as the depth becomes greater. There is no indication of a sudden change in the velocity, such as we should expect if there were any sudden changes in the nature of the earth's interior, but it must be remembered that the greatest depth reached by the deepest path we have drawn is only about halfway to the earth's center, and that our values, especially for the deeper paths, leave much to be desired in accuracy; indeed, the

TABLE 13.— *Velocities of Earthquake Waves at Various Depths below the Earth's Surface.*

DISTANCE BETWEEN ENDS OF PATH.	DISTANCE FROM EARTH'S CENTER, RADIAN.	DEPTH BELOW SURFACE, (km.)	FIRST PRELIMINARY TREMORS.		SECOND PRELIMINARY TREMORS.	
			<i>v</i>	<i>u</i>	<i>v</i>	<i>u</i>
0	1	0	7.2	7.2	4.8	4.8
20	f 0.93 10.955	435 280	9.4	9.75	...	...
40	/ 0.845 1 0.862	980 870	10.7	11.1	5.2'	5.25
70	f 0.693 10.693	1960 1960	12.6	12.4	6.6'	5.8"
100	0.524	3020	...	...	7.3	6.65
110	0.512	3150	12.25	12.7'	...	7.2

results we have reached can only be looked upon as fair approximations to the truth; and we need more numerous and more accurate determinations of the times of transmission of earthquake waves, especially to great distances, before we can reach a satisfactory knowledge of the velocity of propagation at various depths.

## INTERNAL REFLECTIONS.

When the waves of the first two phases come to the surface of the earth they are reflected, and as the density of the air is insignificant in comparison with that of the rock, practically none of the energy escapes into the air. But the reflected energy will be divided between two waves, a longitudinal and a transverse, each of which, therefore, will be weaker than the original waves.<sup>1</sup> Waves will reach a given station, *S* (fig. 29), after a single reflection, from three points on the arc between the focus and the station. The first is the half-way point *B*; from this point an incident longitudinal wave will send a reflected longitudinal wave and an incident transverse wave will send a reflected transverse wave to the station. The second is the point *C*, where the reflected transverse waves, due to incident longitudinal waves, pass off in the proper direction at an angle of reflection smaller than the angle of incidence, because their velocity is less than that of the longitudinal. The third point is *D*, where the transverse waves are transformed into longitudinal waves, which pass on to *S*. There would also be three analogous points *B'*, *C'*, *D'*, on the major arc. When we consider waves which reach *S* after two reflections, we see that they may follow many different paths, as they transform by reflection from one type of wave to the other; there are of course two points, situated at one-third and two-thirds the distance to the station, where reflections can take place

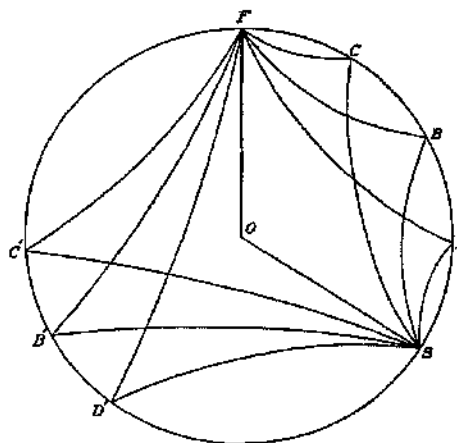

FIG. 29.

<sup>1</sup> The reflection and refraction of waves in elastic media was first thoroly elucidated by Prof. C. G. Knott, "Earthquakes and Earthquake Sounds," Trans. Seismol. Soc. Japan, 1888, vol. xn, pp. 115-136; "Reflection and Refraction of Elastic Waves, with Seismological Applications," Phil. Mag., 1899, vol. XLvii, pp. 64-97, 567-569. He has also given a very interesting account of the subject in his recently published work, "The Physics of Earthquake Phenomena." Prof. E. Wiechert has also discuss this subject ("Ueber Erdbebeiawellen," Nach. d. K. Gesells. d. Wissen. zu Göttingen, Math.-phys. EL, 1907).

without change of type, and the reflected waves will reach *S*; similarly the distance may be divided up into any number of equal lengths, and waves can be reflected successively at all these points without change of type, and reach *S*. It would be very complicated to follow the course of waves of changing type, but the times of arrival at *S* of waves of unchanging type can easily be found. The interval for a singly reflected wave would be twice the interval required to go half the distance, and this interval can immediately be taken from the hodograph. The interval for a wave which has suffered two reflections will be three times the interval required to go one-third the distance, and so on. These reflected waves are probably the most important cause of the variations of intensity during the early phases. The first preliminary tremors are always weak, but the addition of the waves after one reflection to the direct waves may make the latter evident, when without them they would not be. This seems the case at Cairo, Batavia, and the Cape of Good Hope. The times of beginning at these observatories, as given by their directors, are within a half minute of the times at which longitudinal waves would reach them after one reflection.

At the following stations the effects of the longitudinal waves after one reflection can be detected at an interval after the beginning which is given in minutes, these being the proper intervals as determined from the hodograph: Tacubaya, 0.5 minute; stations in Great Britain, 2.5 to 3 minutes; Upsala, slight, 2.5 minutes; Jena, 3 minutes; Munich, slight, 3 minutes; Göttingen, due in 2.5 minutes; slight effect in 3 minutes. The smallness of the effects in all these cases, and the fact that the waves are weakened on reflection by having a portion of their energy transformed into waves of the other type, make it improbable that the effect of longitudinal waves after two or more reflections is at all noticeable at very distant stations.

Horizontal transverse vibrations would suffer no transformation, and as they would practically lose no energy by refraction into the air, their amplitudes would diminish much more slowly than those of the longitudinal waves; they should tend, therefore, to cause marked variations in the intensity of the seismogram, the vibrations being transverse to the direction of propagation. Vertical transverse vibrations would suffer transformation like longitudinal waves, provided the angle of incidence were sufficiently small; if, however, the sine of the angle of incidence becomes greater than two-thirds the ratio of the velocities of the transverse to the longitudinal waves, that is, if the angle becomes greater than about  $42^\circ$ , there will be no transformation, and the transverse waves will be totally reflected as transverse waves. It is quite clear, therefore, that they will preserve their intensity far better than the longitudinal waves, and indeed will get energy from the latter.

When we look for the reflected second preliminary tremors on the seismogram, we are disappointed that they are not more marked, but nevertheless evidences of them can be found on many seismograms. For instance, at Tacubaya the waves reflected once and twice coalesce and appear about one minute after the beginning of the second preliminary tremors; the waves reflected once arrive at stations in Great Britain and in Japan from 4 to 5 minutes after the second preliminary tremors, and those reflected twice in about 6 or 7 minutes; the latter are not evident on the Japanese seismograms. At Bombay the two waves reflected once and twice appear after 9 and 13 minutes; at Batavia they are due after 8.5 and 13 minutes; indications of them are found after 8.5 and between 11.5 and 14 minutes; and many other stations could be cited. It is not entirely beyond question that the strengthenings of the seismograms are due to the reflected waves, both in the case of the first preliminary tremors and the second preliminary tremors; but they occur at the times indicated by the hodograph, and it seems most probable that we have interpreted them correctly.

There is one group of reflected transverse waves which have especial interest, namely, those whose angle of incidence is so large that they experience innumerable reflections, that is, they practically creep around the earth's surface. Professor Knott has suggested that they are the so-called surface waves.<sup>1</sup> But there are certain obvious objections to this idea. They are, that the speed of propagation could not be less than the speed of the transverse waves near the surface of the earth; this speed appears to be about 4.8 km./sec, considerably greater than that of the long waves; again, the energy in the surface waves is much greater than in the second preliminary tremors, but possibly the distribution of energy on account of the change of velocity, with the depth below the surface and the retention of energy by the transverse waves creeping along under the surface, may account for this; lastly, observations do not show consistently that the surface waves are made up in large proportion of transverse waves (see page 114). But, nevertheless, Professor Knott's suggestion is a very interesting one, and it is quite possible that these objections may be overcome when we have more accurate knowledge of the various quantities concerned.

It is difficult to find the time of arrival of waves reflected once in the major arc. The minor arc must be greater than  $120^\circ$  for half the major arc to be less than this value, which is the limit to which the hodograph can be relied upon. The first preliminary tremors, after reflection in the major arc, are apparently too weak to be evident on the seismogram. It would take about 55 minutes for the transverse waves, reflected once on the major arc, to reach stations beyond  $120^\circ$  from the origin; that is, they would reach them at about  $14^h 07^m$ ; at Bombay the motion becomes most irregular at this time; at Batavia there are variations of intensity, but nothing very definite; at Kodaikanal and at Perth the seismograms are stronger at about this time. Altho we can not give the exact time at which reflections on the major arc would reach stations at a less distance than  $120^\circ$  from the origin, the hodographs show that they could not possibly be earlier than the arrival of the regular waves, and, therefore, they are completely masked by the much stronger disturbance existing during the regular waves, the principal part, and the earlier parts of the tail.

#### THE SURFACE WAVES.

In addition to the times of arrival of the first two phases we have plotted in plate 2 the times of arrival of the regular waves. The surface waves are spread over many minutes on the seismogram, but as already noted, we have taken as the beginning of the regular waves that point where the irregular movement (which is a part of, or follows, the second preliminary tremors) becomes regular, with a long period (30 to 50 seconds). The plotted positions of these times of arrival lie very closely along a straight line and no other simple curve could be drawn which would fit the observations materially better. To determine the best straight line to use we resort to the method of least squares, but as the observations differ very much in their reliability, each one is given a suitable weight. No elaborate distribution of the weights has been made. The observations which are considered good have received the weight 5, those which are fair 3, and those which are doubtful 1; a few observations which are very doubtful have been left out altogether. Where several stations have been grouped together the weight of the average is, of course, the sum of the weights of the individual stations. Those observations are considered doubtful which, on account of the absence of the seismogram, could not be checked, or in which the seismogram does not show clearly just where the regular waves begin. In table 14 we have collected the observations which have been used in determining the straight hodograph of the regular waves and their weights.

---

<sup>1</sup> The Physics of Earthquake Phenomena, p. 250.

TABLE 14.—Time Intervals and Weights of Observations for determining the Hodograph of the Regular Waves.

STATION.	DISTANCE.	TIME INTERVAL.	WEIGHT.	STATION.	DISTANCE.	TIME INTERVAL.	WEIGHT.
	°	min.			°	min.	
1. Sitka . . . . .	20.72	10.07	1	13. { Tortosa . . . . . Krakau . . . . . Granada . . . . . Pavia . . . . . Vienna . . . . . Laibach . . . . . Zagreb . . . . . Pola . . . . .	86.01	41.83	25
2. Tacubaya . . . . .	27.70	13.15	3				
3. Toronto . . . . .	32.93	15.40	3				
*• { Washington } Cheltenham }	35.54	17.33	10				
5. Trinidad . . . . .	60.94	29.50	1	14. { Quarto-Cas- tello . . . . . Zi-ka-wei . . . . .	88.16	40.95	5
6. { Paisley } Edinburgh }	72.76	35.20	10				
7. { Tokyo } Bidston . . . . .	74.37	34.78	6	15. Rocca di Papa . . . . .	90.48	45.03	1
8. { Upsala } Shide . . . . .	77.27	37.37	25	16. Ischia . . . . .	91.84	43.93	1
Osaka . . . . .				92.63	44.30	3	
Kobe . . . . .				93.58	44.63	1	
Kew . . . . .				95.04	43.93	3	
§ { Hamburg } Irkutsk . . . . .	80.28	39.03	ft D	19. Catania . . . . .	95.04	43.93	3
10. { Potsdam } Gbttingen . . . . . Coimbra . . . . .	81.37	38.65	15	20. Wellington . . . . .	97.62	49.70	1
11. { Leipzig } Jena . . . . .	82.43	38.80	10	21. Calamate . . . . .	98.28	49.63	1
12. Munich . . . . .	84.75	39.25	5	22. { Christchurch } { Manila . . . . . }	100.43	48.50	2
				23. Calcutta . . . . .	112.72	53.10	1
				24. Bombay . . . . .	121.19	59.30	3
				25. Batavia . . . . .	124.99	61.90	5
				26. Perth . . . . .	132.37	65.80	5
				27. Cape of Good Hope	148.63	81.00	1

The observations used come from 47 stations, but they are only represented on the plate by 27 points, on account of the grouping together of stations at very nearly the same distance from the origin. The hodograph is determined from nearly twice as many stations as would be inferred from a cursory glance at the plate. We can not assume that the straight hodograph, determined from these observations, passes thru the origin; but we seek the position of a straight line in general which will best fit the observations.

The general equation of a straight line is  $y = mx - b$ . In this case  $y$  is the time of arrival of the long waves,  $x$  the distance of the station from the origin in degrees,  $m$  the reciprocal of the velocity of transmission, and  $b$  the point where the line cuts the axis of  $y$ ;  $-b/m$  is the point where it cuts the axis of  $x$ . On working out, by the method of least squares, the most probable values for  $m$  and  $b$  according to the weighted observations, we find

$$m = 0.494 \text{ min./deg.} \quad b = -0.91 \text{ min.} \quad \sqrt{m} = 2.03 \text{ deg./min.}$$

The velocity of the regular waves  $1/m$  is equal to 2.03 deg./min., or 3.75 km./sec.; and the point where the line crosses the axis of  $x$  is given by  $-b/m$ , which equals  $1.84^\circ$  or 205 km. These are the most probable values of the quantities concerned as deduced from the observations, but they are the result of a very limited number of observations and might be modified by results obtained in other earthquakes; and therefore we can not suppose that the constants are very accurately determined. On the other hand, the observations are in fair agreement with each other and therefore the results can not be very far wrong.

The fact that the straight line does not pass thru the origin, but crosses the axis of  $x$  at a distance of 205 km. from the origin does not mean that the regular waves start at this point at the time of the shock. Indeed, we have no observations at all along this part of the line, but there is a very simple explanation of the fact that the line does not pass thru the origin. This is that the regular waves are generated by one of the first two phases at the surface of the earth at a short distance from the origin. The point and

time at which the waves are brought into existence would be one of the two points where the hodograph of the regular waves crosses the hodographs of the first two phases. If the regular waves are started by the first preliminary tremors, this point would be at a distance of  $3.88^\circ$  or 431 km. from the origin; and the waves would begin there 1 minute after the shock occurred. If they were started by the second preliminary tremors they would originate at a distance of  $8.41^\circ$  or 935 km. from the origin and 3.25 minutes after the occurrence of the shock. It seems probable that the surface waves are due in a greater degree to the transverse than to the longitudinal waves, on account of their greater amplitude. As pointed out by Lord Rayleigh, the surface waves expand along the surface in two dimensions, whereas the other waves expand thru the body of the earth in three dimensions; the former, therefore, decrease in amplitude much more slowly than the latter and at distant stations cause a greater movement than the preliminary tremors which started them.

This would account for the preponderance of transverse motion in the principal part of the recorded disturbance, which has been observed in some cases. We must not infer, however, that there are no surface waves nearer the origin than the points we have designated; on the contrary, it is extremely probable that surface waves will be started at all parts of the surface within these distances when the earlier phases arrive there; but as the latter travel more rapidly than the former, new surface waves will be originated in front of them and will always lead them in their passage around the world. It seems probable that the regular waves are the leaders of the surface waves; hence their importance. If there are others which precede them, they are very irregular and their beginning does not produce a sufficiently definite point on the seismogram to be generally recognizable.

The straightness of the hodograph of the regular waves shows that the velocity of propagation is uniform along the arc, and therefore it is practically certain that the waves travel along the surface of the earth and we can apply our equation to determine the time of arrival at any point on the surface when we know its distance from the origin. We thus find 88 minutes as the time necessary to travel  $180^\circ$  to the antipodes.

## PROPAGATION ALONG THE MAJOR ARC.

We could find, from the equation, the time necessary to reach any station by the major arc. This would apply only to the regular waves, but other surface waves, moving with smaller velocities, would take longer times to reach the station. Waves of so many velocities occur that we can not work out the hodographs of them all; and we do not know at what points they start, but it is probable, as in the case of the regular waves, that they start very near the origin and that their velocity will be given with a sufficient approximation by dividing the distance of the station by the time interval of their arrival after the occurrence of the shock. With this method it is very easy to find the time interval of the arrival of waves having the same velocity by the major arc. Let  $T$  represent this interval and  $t$  the interval by the minor arc; let  $d$  be the distance in degrees by the minor arc; then we find, very simply,

$$T = t \frac{360^\circ - d}{d} \quad \frac{(T - t)}{2} = \frac{1(180^\circ - d)}{d}$$

These expressions do not contain the velocity explicitly, and apply to surface waves having any constant velocity. The quantities  $\frac{360}{d}$  and  $\frac{180 - d}{d}$  are constant for each station; and we merely have to multiply the first by  $t$ , the time interval of the surface waves by the minor arc, to obtain the interval after which the corresponding waves would arrive

by the major arc; or we may find the interval between the arrivals of the waves by the two routes by multiplying the second quantity by  $2t$ . This process can be carried out graphically with ease for seismograms having a small time scale, such as those of Milne pendulums. Mark on the seismogram (fig. 30) the point  $o$ , the moment when the earthquake occurred at the focus; at any point, as for instance  $p$ , erect a perpendicular  $p'e'$ , equal in length to  $op' \frac{180^\circ}{d}$ ; draw a straight line  $oe'$ , and produce it; the

height  $pe$  of this line above any point  $p$  of the seismogram will represent half the interval after  $p$ , before the arrival of the surface waves by the major arc, corresponding to those which, following the minor arc, are recorded at  $p$ . If we cut from a sheet of paper

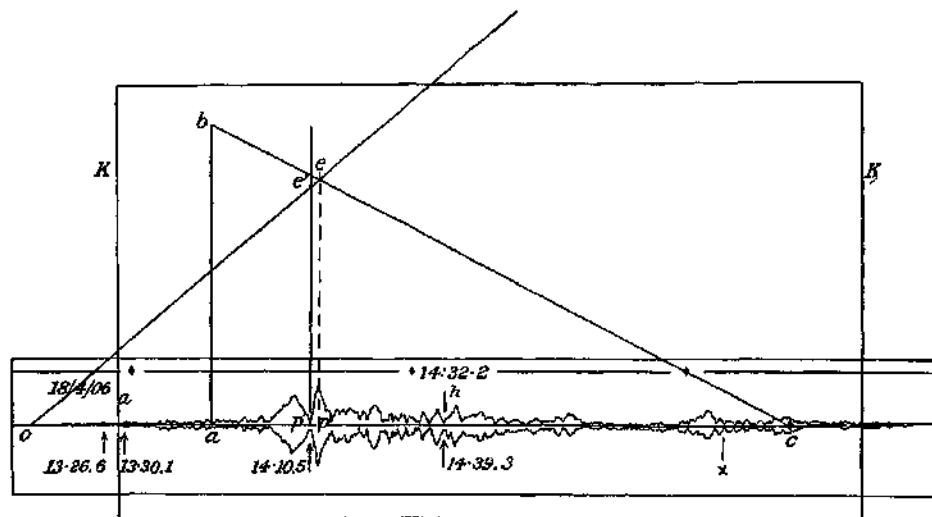

FIG. 30.

$KK$ , a triangle  $abc$ , such that  $ac$  equals  $2ab$ , and place the triangle so that  $ac$  lies along the medial line of the seismogram, the point  $c$  will mark the place where the major arc waves, corresponding to the minor arc waves recorded immediately under the point where  $be$  cuts  $oe'$ , will be recorded; by this device the whole seismogram can be examined in a few minutes. This method must be modified to apply to seismograms with open time scales, and it then requires a very large space; it is simpler, with such seismograms, to calculate  $T$  directly, with a slide-rule, from the first expression given above. When we apply this graphical method to the Milne seismograms we find, in the majority of cases, that there are marked swellings on the seismogram at the time the waves of the strong motion would arrive by the major arc. The seismograms of instruments with open time scales yield much less definite results; indeed, in the majority there is no sufficiently well-marked increase in amplitude to make one certain that the major arc waves have produced any sensible effect.

The seismograms yield various results, as follows:

*Honolulu.* — The swellings from  $16^h 00^m$  to  $16^h 18^m$  mark waves arriving by the major arc corresponding to the strongest motion of the direct minor arc waves. If the strong motion recorded at  $14^h 30^m$  is due to surface waves, the corresponding major arc waves would appear at  $24^h$ , long after the record was over. A small disturbance lasting for an hour is reported about 45 minutes after this time. If the movement mentioned is really due to surface waves arriving by the minor arc, their velocity of propagation would be about 1 km./sec, which is so extremely slow that we are led to discard this explanation of its origin.

*San Fernando.* — The strong group at  $15^{\text{h}} 43^{\text{m}}$  is due to major arc waves corresponding to the strongest part of the motion.

*Kew.* — Major arc waves arrive at  $16^{\text{h}} 08^{\text{m}}$ . Upsala and Kobe show nothing.

*Paisley.* — Major arc waves would be expected at  $16^{\text{h}} 05^{\text{m}}$ . There are many beads in this part of the seismogram, but none especially strong. The very strong swelling,  $16^{\text{h}} 13^{\text{m}}$  to  $16^{\text{h}} 22^{\text{m}}$ , corresponds to minor arc waves arriving 4 minutes after the end of the strongest motion.

*Edinburgh.* — Major arc waves at  $16^{\text{h}} 08^{\text{m}}$  and  $16^{\text{h}} 11^{\text{m}}$ .

*Bidston.* — Major arc waves from  $15^{\text{h}} 40^{\text{m}}$  to  $16^{\text{h}} 00^{\text{m}}$ ; but the earlier and equally strong beads would correspond to much smaller direct waves.

*Tokyo.* — Professor Omori places the arrival of the major arc waves at  $15^{\text{h}} 31^{\text{m}}$ . They would correspond to the direct waves arriving at  $13^{\text{h}} 48.5^{\text{m}}$ .

*Coimbra.* — Major arc waves arrive at  $15^{\text{h}} 40^{\text{m}}$ . The swelling at  $15^{\text{h}} 21^{\text{m}}$  corresponds to the beginning of the long waves which are apparently not so strong. There is a slight increase in intensity at Göttingen at  $15^{\text{h}} 40^{\text{m}}$  and  $15^{\text{h}} 48^{\text{m}}$ . The latter is also apparent at Coimbra. There is no evidence of major arc waves at Jena.

*Irkutsk.* — The major arc waves would be expected at a point on the seismogram opposite the last hour mark, but nothing appears.

*Vienna.* — Major arc waves are due at  $15^{\text{h}} 32.5^{\text{m}}$ , but the seismogram at this point does not differ from the previous part of the record.

*Wellington.* — The large swellings before  $x$  and after  $e'$  are the major arc waves corresponding to the two large swellings on each side of  $e$ , but the major arc waves due to the large movement at  $14^{\text{h}} 25^{\text{m}}$  are not evident.

*Bombay.* — Major arc waves should appear at the gap in the seismogram. The strong swelling at  $15^{\text{h}} 10^{\text{m}}$  corresponds to the beginning of the long waves, but it is so much stronger than the record of the direct waves that we can not correlate them.

*Batavia.* — Nothing definite appears at  $15^{\text{h}} 14.5^{\text{m}}$  and  $15^{\text{h}} 39^{\text{m}}$ , when the major arc waves would be expected.

*Perth.* — There are so many swellings that it is not possible to identify positively the major arc waves. The large swelling at  $15^{\text{h}} 05.5^{\text{m}}$  corresponds to the beginning of the long waves at  $14^{\text{h}} 18.3^{\text{m}}$ , but it is so much stronger than the direct waves that we can not consider it related to them.

If we attempt to find the major arc waves corresponding to the direct waves which produce the largest earth-amplitudes, as they are given in table 19, page 138, we find the evidence of their existence entirely negative. The times of arrival of the direct waves and the major arc waves at several stations are contained in the following table:

TABLE 15.—•Times of Arrival of Corresponding Minor and Major Arc Waves.

STATION.	MINOR ARC WAVES.		MAJOR ARC WAVEB.	
	<i>m.</i>	<i>s.</i>	<b>m.</b>	<b>s.</b>
Upsala . . . . .	13	51	15	36
Göttingen . . . . .	13	53.5	15	38
Leipzig . . . . .	13	55.5	15	37.5
Jena . . . . .	13	59	15	59.5
Vienna . . . . .	14	17.5	15	14.5
Batevia . . . . .	14	36.5	15	39

There are three stations situated practically on the same great circle passing thru the origin: Coimbra ( $81.4^{\circ}$ ), San Fernando ( $85.3^{\circ}$ ), and Wellington ( $262.4^{\circ}$ ), and they all have Milne pendulums. The major arc waves which arrive at Wellington at  $15^{\text{h}} 36^{\text{m}}$  cause the latter part of the strong motion at Coimbra at  $13^{\text{h}} 57^{\text{m}}$ . They should appear at



San Fernando at 13<sup>h</sup> 59<sup>m</sup>, and probably are indicated by the strong motion a minute earlier; the major arc waves arriving at Wellington at 15<sup>h</sup> 52<sup>m</sup> appear at Coimbra at 14<sup>h</sup> 01<sup>m</sup>, and cause the strong motion at San Fernando at 14<sup>h</sup> 04<sup>m</sup>. The direct waves at Wellington at 14<sup>h</sup> 07<sup>m</sup> and 14<sup>h</sup> 12.5<sup>m</sup> are due at San Fernando at 15<sup>h</sup> 41<sup>m</sup> and 15<sup>h</sup> 50<sup>m</sup> and are undoubtedly represented by the strong swelling about 15<sup>h</sup> 43<sup>m</sup>; they are due at Coimbra at 15<sup>h</sup> 43<sup>m</sup> and 15<sup>h</sup> 53<sup>m</sup>; these are weak parts of the curve, but probably the swellings a few minutes earlier than these times represent the waves we are considering.

We must conclude, from the foregoing survey, that altho the strong motion arriving by the major arc makes itself evident at some stations, perhaps on account of synchronism of its period and that of the recording instrument, at other stations it can not be detected. The small time scale of the Milne seismograms is much better adapted for identifying the major arc waves than the open time scale of other instruments.

#### EQUALITY OF VELOCITIES ALONG DIFFERENT PATHS.

As already pointed out, all the distant stations had instruments of low magnifying power and apparently were too late by various amounts in recording the shock; so we must confine our attention to stations less than 100° distant. On comparing the times of arrival of the various phases (given in table 7, page 116) at stations nearly equally distant, we can not find any differences, greater than the errors of observation, which might be dependent upon the direction of the station from the origin; and this applies to all three phases of the motion. Thus, Honolulu receives the second preliminary tremors a little earlier than the observations at stations in the east of North America would lead us to expect (see hodograph, plate 2), but the first preliminary tremors arrive at the expected time. The paths to Honolulu and these stations are totally different, the first being under the Pacific and the other across the continent of North America, as shown in plate 1.

The Japanese, on the one hand, and the British and Scandinavian stations, on the other, are about equally distant from the origin; the path to the former lies under the deep Pacific, that to the latter across North America, Greenland, and under the shallow North Sea; but we do not find a greater difference between the times of arrival at these two groups of stations than we do between the individual stations of the same group.

Irkutsk and Jurjew are at practically the same distance from the origin; the path to Irkutsk passes under the Pacific, across Alaska and northeastern Asia; the path to Jurjew crosses North America and Greenland and continues under the North Sea; yet the times of arrival at the two stations are within a very few seconds of each other.

We conclude, therefore, that the velocity of propagation is independent of the position of the projection of the path on the earth's surface; or, at least, is too little affected by it to be detected by our observations.

#### COMPARISON OF THE HODOGRAPHS OF THE CALIFORNIA EARTHQUAKE WITH OTHER OBSERVATIONS.

When we compare the hodographs obtained from the California earthquake with those given by Professor Milne in 1902\* and with those of Professor Oldham, 1900,<sup>3</sup> we find that our times of arrival of the first and second preliminary tremors are, for the greater part of the curves, about 2 minutes earlier. This appears to be due to lack of accuracy in the earlier observations, and a glance at the earlier diagrams will show that the curves are drawn from observations differing greatly among themselves.

<sup>1</sup> Report Seis. Com. B. A. A. S., 1902.

\* On the Propagation of Earthquake Motion to Great Distances. Phil. Trans. R. S., 1900-1901, vol. 194, pp. 135-174.

The hodograph of the "large waves" of Professor Milne in the earlier observations does not refer to the same surface waves as those which are here tabulated as *regular waves*, but to the time of maximum displacements on the seismograms. The position of the maximum is very largely dependent upon the proper period of the recording pendulum, and the instruments whose records we have of the California earthquake differed so greatly in this respect that it is not possible to identify as a maximum any characteristic part of the disturbance; except for a limited number of seismograms.

In his very interesting memoirs on the propagation of earthquake motion, Prof. G. B. Rizzo gives hodographs of the two Calabrian earthquakes of September 8, 1905, and October 23, 1907. The former was a severe earthquake and was recorded all over the world. The latter was much smaller and satisfactory observations were only obtained up to distances of about  $22^\circ$ . The hodographs of the first and second preliminary tremors agree very well with my curves, except about  $20^\circ$  and in the immediate neighborhood of the origin, where Professor Rizzo has made his curve convex upward to represent the assumed changes in surface velocity; and he has measured his times from the estimated time of arrival of the disturbance at the epicenter, whereas I have measured time from the actual time of occurrence of the shock at the focus, and have assumed the velocity of 7.2 km. per second for short distances from it.

Professor Omori, in his very complete account of the seismograph records of the Kangra earthquake of April 4, 1905/ gives the hodographs of the first and second preliminary tremors and a later phase of the principal part; the latter, however, does not correspond to the regular waves which I have recorded. The hodographs of the first two phases correspond fairly well with those of the California earthquake<sup>2</sup> up to distances of about  $60^\circ$  for the first preliminary tremors and  $90^\circ$  for the second preliminary tremors; but beyond they diverge greatly. It is rather curious that the observations of the Indian earthquake are most numerous between  $37^\circ$  and  $60^\circ$ , in which interval there is but one observation of the California earthquake; whereas, between  $70^\circ$  and  $100^\circ$ , where the great majority of the observations of the California earthquake lie, there are but four very unsatisfactory observations of the Indian earthquake. The cause of the disagreement between the observations at the greater distances is very evident. All the observations of the Indian earthquakes at distances greater than  $60^\circ$  are made with instruments of very low magnifying power, and it is hardly possible that the true beginning of the disturbance has been recorded. With regard to the second preliminary tremors it is a question of the interpretation of the seismograms. Of the four observations which Professor Omori uses beyond  $90^\circ$  three are from Bosch-Omori 10 kg. instruments, and I think it quite impossible from an examination of their seismograms to determine where the second preliminary tremors really began. The other record, at Wellington, was made by a Milne pendulum, and the time I take to mark the arrival of the second preliminary tremors is nearly 10 minutes earlier than that taken by Professor Omori, and is between 2 and 3 minutes later than my curve would lead us to expect. The record at Christchurch,  $0.7^\circ$  nearer the origin, is 2.5 minutes earlier. The Milne seismograms from Victoria, Toronto, Baltimore, and Christchurch (from  $97.7^\circ$  to  $115^\circ$ ) are not used by Professor Omori in making his hodograph of the second preliminary tremors, tho he reproduces them among his plates. As I read them, the times of arrival of the second preliminary tremor are in fair agreement with my curves and are from 8 to 12 minutes earlier than the times adopted by Professor Omori for similar distances. He is thus led to nearly linear hodographs of the first and second preliminary tremors, and consequently to a linear relation between the distance of an earthquake origin and the duration of the first preliminary tremors.

<sup>1</sup> Report on the Great Indian Earthquake of 1905. Pub. Earthquake Investigation Committee in Foreign Languages, Nos. 23 and 24.

\* Professor Omori also gives the velocities obtained from the California earthquake in the same report, but he has taken the time of the shock a half minute too early.

TABLE 16. — *Transmission Intervals (in minutes) for Three Earthquakes.*

DISTANCE.	FIRST PRELIMINARY TREMORS.				SECOND PRELIMINARY TREMORS.			
	Indian.	Calabrian.	California.	Average.	Indian.	Calabrian.	California.	Average.
0	<i>min.</i>	<i>min.</i>	<i>min.</i>	<i>min.</i>	<i>min.</i>	<i>min.</i>	<i>min.</i>	<i>min.</i>
10	2.6	2.24 <sup>1</sup>	2.4	2.41	4.6	4.06	3.85	4.17
20	4.5	4.26*	4.3	4.35	8.4	8.05	7.6	8.02
30	6.2	6.12	6.1	6.14	11.3	11.26	10.9	11.15
40	7.6	7.35	7.7	7.55	13.9	13.80	13.8	13.83
50	9.0	8.51	9.0	8.84	16.2	16.24	16.3	16.25
60	10.6	9.67	10.2	....	18.9	18.68	18.6	18.73
70	12.2	10.78	11.35	....	20.7	21.12	20.6	20.81
80	13.9	11.89	12.3	....	24.7	23.57	22.25	....
90	15.7	13.00	13.25	....	27.5	26.00	24.0	....
100	17.3	14.11	14.2	....	30.4	28.56	25.6	....

In table 16 have been collected the transmission intervals in minutes for the first and second preliminary tremors of the Indian earthquake of April 4, 1905, the Calabrian earthquake of September 8, 1905, and the California earthquake of April 18, 1906. The data for the Indian earthquake are taken from plates in and iv of Professor Omori's report, that of the Calabrian earthquake from table 2 of Professor Rizzo's first memoir,<sup>1</sup> and that of the California earthquake from table 11, page 120 of this report. A very close agreement exists up to 50° for the first preliminary tremors and up to 70° for the second preliminary tremors, with the exception of the interval at 20°, and we may accept the averages given as representing to a very fair degree of accuracy the time intervals necessary to travel the corresponding distances. The four intervals marked are from Professor Rizzo's second memoir<sup>2</sup> and refer to the Calabrian earthquake of October 23, 1907; they are a little shorter, and I think a little more accurate, than the corresponding intervals for the earlier earthquake.

#### DETERMINATION OF THE DISTANCE OF THE ORIGIN OF AN EARTHQUAKE.

Professor Milne in 1898<sup>3</sup> showed that the distance of an earthquake from the recording station could be determined by the interval of time between the beginning of the disturbance and the arrival of the large waves, and he drew a preliminary curve to represent this relation. In 1902<sup>4</sup> he gave more accurate results based on more abundant data. Professor Omori has followed up this subject and has drawn curves and given equations to determine the distance of the origin from the duration of the first preliminary tremors and from the interval between the first preliminary tremors and the long waves.<sup>5</sup> His relations are linear, one equation being given for near origins and a second for distant origins.

In fig. 31 curves are drawn which are taken directly from the hodographs in plate 2 and show the interval elapsing between the first and second preliminary tremors, between the first preliminary tremors and regular waves, and between the second preliminary tremors and regular waves. These three curves are of course not independent; any one of them could be deduced directly from the other two. By means of them a typical seismogram will give two independent determinations of the distance of an earthquake origin. These

<sup>1</sup> Nuovo Contributo allo Studio della Propagazione dei Movimenti Sismici, Acad. R. d. Scienze di Torino, 1907-1908, vol. LIX, p. 415.

<sup>2</sup> Sulla Velocità di Propagazione della Onde Sismiche, Acad. R. d. Scienze di Torino, 1905-1906, vol. LXVII.

<sup>3</sup> Report Seis. Com. B. A. A. S., 1898.

<sup>4</sup> Same, 1902.

<sup>5</sup> Pub. Earthquake Investigation Commission in Foreign Languages, Nos. 5 and 13, Bull. Imperial Earthquake Investigation Commission, vol. n, pp. 144-147. A Report on the Great Indian Earthquake of 1905. Publications, etc., No. 24, pp. 179-186.

curves have a certain advantage over most similar curves heretofore given because the time and origin of the California earthquake are known to a higher degree of accuracy and because more and better instruments have recorded this shock than were in use in earlier times. Nevertheless, they are free-hand curves, and the observations not perfectly concordant, both of which facts reduce their accuracy. Moreover, the duration of the first preliminary tremors increases very slowly with the distance from the origin, which makes the determination of the distance by means of the interval rather inaccurate. It will be seen that the lines are not straight, altho their curvatures are not very great. The interval between the first and second preliminary tremors are given from the origin, because both these phases apparently begin there, but the curves dependent upon the regular waves start about  $10^\circ$  from the origin; the first observation we have of the regular waves is at a distance of about  $20^\circ$ ; and the parts of the curves nearer the origin are drawn on the supposition that the hodograph of the regular waves continues as a straight line to within  $10^\circ$  or so of the origin.

The time of the occurrence of the shock, and therefore the early part of the hodographs, is based on the assumption that the velocity of the first preliminary tremors is 7.2 km./sec. near the origin, and that of the second preliminary tremors in the same region, 4.8 km./sec. These values fit very well into the general curves of the hodographs; but that would also be true of values differing 10 or 15 per cent from them; but it would hardly be true for values differing more than this.

The duration of the first preliminary tremors does not depend upon those values, but upon the record at Mount Hamilton, where it was 9 seconds.

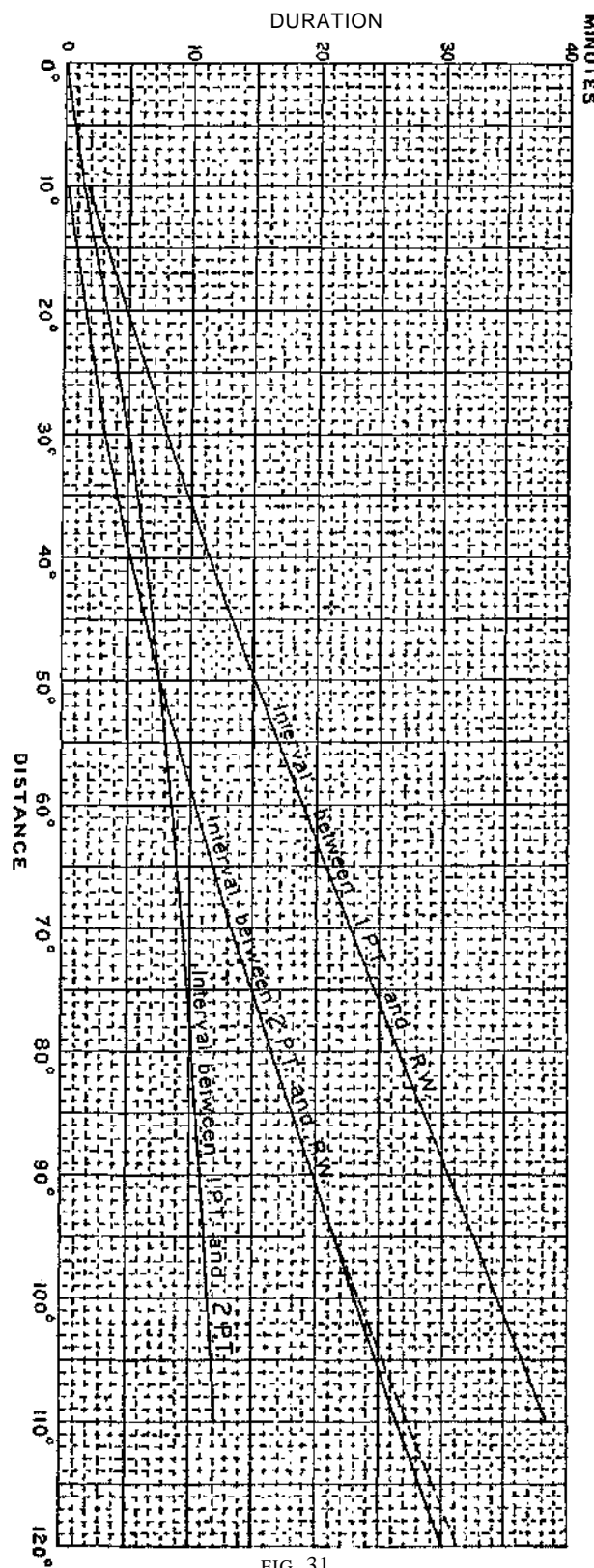

FIG. 31.

Mount Hamilton is about 128 km. from the origin, and if we assume that for distances of a few hundred kilometers the duration of the first preliminary tremors is proportional to the distance which the approximate straightness of the hodographs of the first two phases near the origin indicates, we find the following relation between the distance  $d$  and the duration  $I'$  of the first preliminary tremor:

$$d(\text{km.}) = 14.2 * I' (\text{sec}).$$

As the position of the origin is not known nearer than 20 km. the number in the second member may lie anywhere between 12 and 16.2.

PERIODS AND AMPLITUDES.

The study of the seismograms reveals the periods of the vibrations in different parts of the disturbance as recorded at a number of stations. The actual amplitude of the earth movement can only be determined by a calculation which depends upon the period of the waves, the period of the pendulum, and the constants of the instruments. The calculation is made in accordance with the formulas, equations 79 or 81, page 169. In many cases the period of the pendulum is the same as that of the vibration and then, if there is not very strong damping, the magnifying power becomes indefinitely large and is undeterminable; this is the condition at many stations where large movements are recorded by the seismographs; but it has been possible, in a number of cases, to determine roughly the true movement of the ground. The amplitudes on the two components at right angles to each other do not always reach their maxima at the same time; it sometimes happens that the movement is alternately strong on one component and the other. This was the case at Porto Rico, Upsala, and Pavia. Even when the maxima occur on the two components at the same time, one does not always get the true amplitude of the earth's motion by taking the square root of the sum of the squares of the two components, for the difference of phase has an influence; but this is the only method we can use, and the quantities given in the column headed "Poss. total" in table 19 were obtained in this way.

DURING THE PRELIMINARY TREMORS.

The vibrations during the first preliminary tremors frequently have periods in the neighborhood of 5 seconds; other periods were also present, but were not so persistent. At Jurjew the period during the first preliminary tremors was 29 to 30 seconds. It seems as tho there were many periods present and that the period which was close to that of the instrument was singled out and made prominent. At Sitka a period of about 17 seconds was shown.

During the second preliminary tremors vibrations of various periods were also present, but those which had the largest amplitude seem to be about 15, 20, and 28 seconds.

TABLE 17. — *Periods and Amplitudes during the Preliminary Tremors.*

STATION.	DISTANCE.		DIRECTION OF APPROACH.	COMPONENT.	FIRST PRELIMINARY TREMORS.		SECOND PRELIMINARY TRIMOWU		
	°	km.			Amplitude.	Period.	Amplitude.	Period.	Time.
Sitka . . .	20.72	2302	N. 27° W.	North . . .	mm. 0.48	sec. 17	mm. 0.215?	Me. 15	h. m. »»»
Ottawa . . .	35.37	3930	N. 85° W.	North . . .	0.004	6.7*	.....	..	.....
Washington . . .	35.44	3937	N. 75° W.	East . . .	0.005	6 <sup>1</sup>	.....	..	.....
Upsala . . .	76.80	8533	N. 29° W.	North . . .	.....	.....	0.2 i'	28	13 "k
Osaka . . .	77.30	8589	N. 55° E.	North . . .	0.0013	*4	0.37	19	13 44
Jurjew . . .	80.27	8918	.....	East . . .	0.01	5	.....	..	.....
Potsdam . . .	81.35	9039	N. 37° W.	.....	.....	29-30	.....	..	.....
Irkutsk . . .	80.82	.....	.....	North . . .	.....	5	0.17'	23	.....
Gb'ttingen . . .	81.36	9040	N. 39° W.	East . . .	.....	.....	0.12	27	13 45
Leipzig . . .	82.40	9155	N. 38° W.	East . . .	.....	37'60	.....	..	.....
Jena . . .	82.45	9161	N. 39° W.	Vertical . . .	.....	1,2,5	0.041	16	Him
Munich . . .	84.75	9417	N. 39° W.	North . . .	0.0024	5,8	.....	..	.....
Vienna . . .	86.37	9596	N. 37° W.	East . . .	0.0018	5,9	0.028	20	13*3ft
Batavia . . .	124.99	13887	N. 50° E.	East . . .	0.0052	4,8	0.11"	ill	13 3ft
				North . . .	0.0023	4,10	0.0155	20	.....
				East . . .	0.0023	5	0.0034	15	13 3ft
				North . . .	0.022	5	.....	..	.....
				East . . .	0.1118	.....	.....	..	.....
				North . . .	0.00M	5, 8, 10	0.0 Vifi ?	M	.....

\* Uncertain on account of clewaeM of p<i>it<sup>h</sup>

The amplitudes recorded are very small and are not very regular. The nearest point where a determination could be made for the first preliminary tremors was Sitka, and there the earth-amplitude was just under 0.5 mm. At Ottawa it had already diminished very greatly, being about one-hundredth as much for both components. These values are somewhat uncertain, as the periods were very near those of the pendulums. Table 17 shows the amplitudes at a number of stations; in general they lie between 0.002 mm. and 0.02 mm. The reason for the absence of a progressive diminution is not at all clear. It does not seem to be sufficiently accounted for by differences in the foundation. It is possible that the discordance may be largely due to inaccuracy in the constants of the instruments, especially the omission of the solid friction, and also, possibly, to the application of the formula to parts of the record where the movement has not been sufficiently regular for the formula to apply accurately.

During the second preliminary tremors there is a very large increase in the amplitude, to about 10 times that of the first preliminary tremors; we find the same kind of irregularity in the amplitudes at successive stations but we do not find the proportion between the amplitudes of the first and second preliminary tremors constant; at Leipzig, the amplitude of the second preliminary tremors was 10 times that of the first preliminary tremors, whereas at Jena it was 20 times as great. This probably indicates a lack of accuracy in the determination of earth-amplitudes.

DURING THE REGULAR WAVES AND THE PRINCIPAL PART.

*In the megaseismic district.* — The temporary nature of the vibrations makes it impossible to get satisfactory measures of the amplitudes, unless a permanent record of some kind is made. There are, fortunately, a few such records which enable us to form a rough conception of the amount of the movement.

Professor Omori, guided apparently by the damage done, estimates that, on the filled-up grounds of San Francisco, the amplitude of the vibration was 50 mm. (2 inches), and the period 1 second.<sup>1</sup> The distance from the fault was about 14 km.

On the rock at Berkeley Observatory (distant 30 km.) the vertical component of the amplitude was 23 mm. (1 inch), and the horizontal component, according to the Ewing duplex pendulum, more than 11 mm.

At Mare Island (distant 40 km.) Professor See estimated the horizontal amplitude in the soft made ground at 50 to 75 mm. from the displacement of loose dirt about piles which supported buildings (vol. I, p. 212).

At a number of stations in the megaseismic district, given in table 18, which were provided with simple instruments, the amplitude of the movement was greater than the instruments could record, that is, in general, was greater than 10 mm.; and it is probable that it was several times greater.

TABLE 18. — *Amplitudes in the Megaseismic District.*

STATION.	DISTANCE FROM FAULT.	COMPONENT.	DISPLACEMENT.
	<i>km.</i>		<i>mm.</i>
Los Gatos . . . . .	6	Horizontal	5+
San Francisco . . . . .	14	Horizontal	50
San Jose . . . . .	18	Horizontal	10+
Oakland . . . . .	24	Horizontal	10 +
Alameda . . . . .	29	Horizontal	10+
Berkeley . . . . .	30	Vertical	23
		Horizontal	11+
Mount Hamilton . . . . .	35	North-south	40+
		East-west	40+
Mare Island . . . . .	40	Horizontal	50 to 75
Carson City . . . . .	291	Horizontal	11

<sup>1</sup> Bull. Imperial Earthquake Investigation Commission, vol. 1, p. 19.

At Mount Hamilton ( $1.16^\circ$  or 129 km. from the origin and 35 km. from the fault) the 3 component Ewing instrument indicated amplitudes, both in the north-south and east-west directions, greater than 40 mm.

At Carson City ( $2.62^\circ$  or 291 km.) the horizontal amplitude was about 11 mm. in all directions.

*Beyond the megaseismic district.*— We have collected in table 19 the periods and the greatest earth-amplitudes at all the stations for which we have sufficient data to determine these quantities. In a few cases they are taken directly from published reports. At many stations there was so close a correspondence between the period of the vibrations and that of the pendulum during the very strong motion that it was impossible to make any determination of the earth-amplitude.

It will be seen that the periods of vibration during the regular waves were, in general, not very far from 30 seconds, tho in a few cases they were 10 or 12 seconds less, and in a few 10 or 20 seconds more. During the principal part the periods were principally between 17 and 25 seconds.

Where we have determinations of the earth-amplitude during both the regular waves and principal part at the same station, the former seems to be somewhat the larger, altho the instrumental record on the seismogram is almost always larger during the principal part. This is due to the variations in the magnifying power of the instrument on account of difference in periods.

Altho the amplitudes do not diminish regularly with the distance from the origin, nevertheless with the exception of a few abnormal values, which are not understood, there is in general a reduction of amplitude with the distance. In the megaseismic region we found that these amplitudes were 50 mm. or more; at distances of  $30^\circ$  to  $50^\circ$  they have diminished to about 5 mm., and we must go as far as  $100^\circ$  or so to find amplitudes less than 1 mm. We see, therefore, that the great world-shaking earthquakes cause movements of the earth at great distances which are by no means inconsiderable, and the only reason why they are not felt is that the period is very long, and, therefore, the movement too slow to make them evident to our senses.

In attempting to determine the depth of the fault (page 13) we were led to assume that the energy is sent out from the fault-plane proportionally to the cosine of the angle between the direction of propagation and the normal. Altho this will probably hold approximately in the neighborhood of the fault, it does not hold at a distance, where the distribution of the energy, so far as we can tell from the altogether unsatisfactory determinations that could be made, is entirely independent of the direction from the origin. For instance, Sitka and Tacubaya, whose directions make angles  $16^\circ$  and  $29^\circ$ , respectively, with the direction of the fault, have apparently instrumental amplitudes similar to those of the stations in the eastern part of North America, whose direction is nearly at right angles to the fault-plane. Pilar, Argentina, and the Cape of Good Hope, whose directions make angles of  $12^\circ$  and  $51^\circ$  with the fault, gave very small records, whereas Mauritius (nearly  $35^\circ$ ) gave a much larger record. Calcutta, Kodaikanal, and Bombay ( $5^\circ$  to  $16^\circ$ ) also gave much larger records.

In looking over the table of earth-amplitudes, to compare the results between stations at about the same distances from the origin, but in different directions, we find the irregularities so great that no satisfactory conclusions can be drawn. We notice, however, that Zi-ka-wei had about the same amplitude during the principal part as Carloforte and Sarajevo; and that the amplitudes at Sofia, Catania, and Manila do not differ greatly during the regular waves; but these comparisons carry very little conviction with them, because of the great variations between the amplitudes at various European stations, which do not differ greatly in their distances from the focus nor in their directions from it.



TABUS 19.—Periods and Amplitudes during the Regular Waves and the Principal Part.

STATION.	DIS-TANCE.	COMPONENT.	REGULAR WAVES.				PRINCIPAL PART.						
			Ampli-tude.	POM. total.	Period.	Time.	Ampli-tude.	POBS. total.	Period.	Time.			
			mm.	mm.	sec.	h.	m.	mm.	mm.	sec.	h.	m.	
Cheltenham .	35.64	North	2.3+	5	13	13	34	3.2+	5	13	13	34	
		East	3.6	5.2	33	13	50-52	3.76	5.2	9	13	36	
Upsala . . .	76.80	North	1.7	4	41	13	53	2.7	4	23.2	13	56	
		East	0.8+	4	30	13	53	2.2	4	28	13	56	
Potsdam . . .	81.35	North <sup>1</sup>	0.97+	1.6+	30	13	52-55	1.5	1.6+	22	13	56	
		North <sup>2</sup>	1.31+	1.6+	30	13	52-55	0.52+	1.6+	20	13	59	
		East <sup>2</sup>	1.64	1.6+	49	13	52-55	0.52+	1.6+	20	13	59	
		Vertical	0.58	1.6+	49	13	52-55	0.7	1.6+	14.5	13	59	
Leipzig . . .	82.40	North	2.2	3.2	34.5	13	55.7	1.55/	3.2	1.65	13	57.5	
		East	1.81	3.2	30	13	54-56	2.0+	3.2	20	13	57.5	
Jena . . . .	82.45	North	2.6	3.2	30	13	54-56	1.5+	3.2	20	13	57.5	
		East	1.9	3.2	30	13	54-56	2.5+	3.2	20	13	57.5	
Munich . . .	84.75	North	0.47	1.35	29.5	13	52	0.77+	1.35	22.5	13	58	
		East	1.26	1.35	35.5	13	52	1.25+	1.35	24.2	13	58	
		North 30° east	0.59	1.35	35.5	13	52	0.77+	1.35	22.5	13	58	
Strassburg .	82.91	East	0.47	1.35	35.5	13	52	1.25+	1.35	24.2	13	58	
Tortosa . . .	85.65	Average	2.7	3.2	27	13	56	1.36	3.2	16.4	14	04	
		Northeast	2.7	3.2	27	13	56	2.2	3.2	15.7	14	04	
Pavia . . . .	86.20	Southwest	0.19	10.28	26.2	13	59	3.1	10.28	16.4	14	03	
		North	0.21	10.28	23.4	13	59	0.13	10.28	18.8	14	08	
Vienna . . .	86.37	East	0.14	10.28	23.4	13	59	0.16	10.28	16.9	14	08	
		North	1.1	10.28	23.4	13	59	0.14	10.28	18	14	08	
		East	0.1	10.28	23.4	13	59	1.1	10.28	18	14	08	
Triest . . . .	87.74	Vertical	0.9	10.28	23.4	13	59	0.1	10.28	17	14	06	
		North	1.42	10.28	23.4	13	59	0.9	10.28	1	14	06	
Budapest . .	87.93	North*	2.5	10.28	23.4	13	59	1.42	10.28	15	14	06	
		East <sup>6</sup>	1.06	10.28	23.4	13	59	2.5	10.28	26	14	06	
		North*	0.33	10.28	23.4	13	59	1.06	10.28	26	14	06	
O'Gyalla . .	88.08	East <sup>7</sup>	0.64?	10.28	23.4	13	59	0.33	10.28	17	14	02	
		North <sup>8</sup>	4.1	10.28	23.4	13	59	0.64?	10.28	19	14	00.5	
Florence (Xi-	88.23	East <sup>8</sup>	2.6	10.28	23.4	13	59	4.1	10.28	17.6	14	00.5	
meniano) . .		North*	3.9?	10.28	23.4	13	59	2.6	10.28	17.6	14	00.5	
Zagreb . . .	88.33	East <sup>9</sup>	2.8?	10.28	23.4	13	59	3.9?	10.28	21	14	01	
		North	1	10.28	23.4	13	59	2.8?	10.28	21	14	01	
Pola . . . .	88.33	East	1.9	10.28	23.4	13	59	1	10.28	20.4	14	04	
		North	10.1	10.28	23.4	13	59	1.9	10.28	20.4	14	02	
Quarto-	88.40	East	1.18	10.28	23.4	13	59	10.1	10.28	30	14	04	
Castello . .		East	0.5	10.28	23.4	13	59	1.18	10.28	19	14	05	
		East	0.39	10.28	23.4	13	59	0.5	10.28	26.4	13	58	
Zi-ka-wei .	88.49	Northwest	1.1	10.28	23.4	13	59	0.39	10.28	29.6	14	09	
		North	0.821	10.28	23.4	13	59	1.1	10.28	19	14	09	
		East	1.14/	10.28	23.4	13	59	0.821	10.28	17	14	07.3	
RocadiPapa .	90.48	Northwest	0.6	10.28	23.4	13	59	1.14/	10.28	14	14	07.3	
		Northwest	0.6	10.28	23.4	13	59	0.6	10.28	17	14	07	
Carloforte .	90.71	Northeast	0.6	10.28	23.4	13	59	0.6	10.28	0.85	17	14	07
		North	Small	10.28	23.4	13	59	0.6	10.28	17	14	07	
		East	0.53	10.28	23.4	13	59	Small	10.28	24.5	14	03.7	
Sarajevo . .	90.89	East	0.46	10.28	23.4	13	59	0.53	10.28	17.6	14	10.5	
		East	0.43	10.28	23.4	13	59	0.46	10.28	17	14	14.7	
		Northwest	0.68	10.28	23.4	13	59	0.43	10.28	17	14	14.7	
Caggiano . .	92.63	Northeast	2.2+	10.28	23.4	13	59	0.68	10.28	19.9	14	07.3	
		East	0.25	10.28	23.4	13	59	2.2+	10.28	25.3	14	04.2	
Taihoku . . .	92.75	North	0.25	10.28	23.4	13	59	0.25	10.28	22	14	00	
Sofia . . . .	93.58	Northwest	1.66	10.28	23.4	13	59	0.25	10.28	22	14	00	
		Northeast	0.3	10.28	23.4	13	59	1.66	10.28	22	14	07.8	
Messina . . .	94.67	Vertical	0.25	10.28	23.4	13	59	0.3	10.28	17	14	07.8	
		Northeast	0.58	10.28	23.4	13	59	0.25	10.28	22	14	07.8	
		Northeast	0.58	10.28	30	13	57.5	0.58	10.28	22	14	07.8	
Catania . . .	95.04	Northwest	0.72	10.28	30	13	57.5	0.72	10.28	0.8	18	14	12.8
		North <sup>1</sup>	0.72	10.28	30	13	57.5	0.72	10.28	18	14	07.1	
Taschkent . .	99.86	East <sup>7</sup>	3.0	10.28	30	13	57.5	3.0	10.28	24	14	10.9	
		East-northeast	20	10.28	30	13	57.5	20	10.28	32	14	21.3	
Manila . . .	100.46	North-northwest	0.75	0.84	25	14	01	0.44	0.84	18	14	08	
		North	0.45	0.84	18	14	01	0.4	0.84	18	14	08	
Batavia . . .	124.99	North	0.38	0.84	23	14	17.5	0.24	0.84	18.4	14	30.6	

<sup>1</sup>Rebur-Paachwit\*.  
<sup>2</sup>Wiechert.

<sup>3</sup>17,000 ke.  
<sup>4</sup>< 1,200 kg.

<sup>5</sup>Vicentini.  
<sup>6</sup>Konkoly.

<sup>7</sup>Bosoh-Omori.  
<sup>8</sup>\*Stiattesi.

### MAGNETOGKRAPI RECORDS.

Several magnetographs at stations not very distant from the origin recorded the shock. These have been examined by Dr. L. A. Bauer/ who finds that the time of disturbance on the magnetograph corresponds to the time of arrival of the principal part, and concludes, therefore, that the effect is entirely mechanical and not magnetic. The following table shows the time of the magnetograph records and the time of arrival of the regular waves, according to Dr. Bauer.

TABLE 20. — *Times of Magnetograph Records.*

STATION.	DISTANCE.	MAGNETOGRAPH RECORD.		REGULAR WAVES.	
		<i>h.</i>	<i>m.</i>	<i>A.</i>	<i>TO.</i>
	0				
Sitka . . . . .	20.7	13	22.9	13	22.6
Baldwin . . . . .	21.8	13	24		
Toronto' . . . . .	32.9	13	25.3	<sup>2</sup> 13	24.5
Honolulu . . . . .	34.6	13	27.8	<sup>3</sup> 13	28.5
Cheltenham . . . . .	35.6	13	30	13	30
Porto Rico . . . . .	53.4	Not recorded		....	

<sup>1</sup> The Toronto record was communicated by Mr. B. F. Stupart, director of the Canadian Meteorological Service. The records of the other stations are taken from Dr. Bauer's article.  
<sup>2</sup> Time of the second preliminary tremors; the regular waves are 3.4 minutes later.  
<sup>3</sup> Not determined from the seismogram, but from the hodograph curve, plate 2.

It will be seen that the magnetographs recorded only during the time of the strong motion, which convinces us that they acted mechanically like seismographs, for if they had been affected by a magnetic disturbance due to the earthquake, the effect would have been produced long before the arrival of the slow surface waves; indeed, before the arrival of any elastic waves in the mass of the earth. The maximum disturbance of the Toronto declination needle occurred at 13<sup>h</sup> 33.6<sup>m</sup>; and the maximum recorded by the seismogram at 13<sup>h</sup> 33.3<sup>m</sup>.

Baldwin, Kansas (lat. 38° 47' N., long. 95° *IW* W.), is the only one of these stations that did not have a seismograph; and the magnetograph record began about 1.5 minutes after the regular waves must have reached there according to the hodograph. Being in the middle of the United States, far from any seismographic station, an accurate record at Baldwin would have been valuable; but the time scales of magnetographs are too small to yield close time values; and they do not, in general, record before the strong motion. The Baldwin record is therefore only valuable in so far that it does not contradict the results obtained from regular seismographs; and we can not hope that magnetograph records in the future will, in general, be important additions to the records of seismographs.

<sup>3</sup> "Magnetograph Records of Earthquakes with Special Reference to the San Francisco Earthquake." *Terrest. Magn. and Atmos. Elect.*, 1906, vol. xi, pp. 135-144.

## CONCLUSIONS.

The comparative study of the seismograms made by instruments of such varied types brings out the advantages and disadvantages of the various types and of the devices used in making the record.

*Time.* — It is extremely important that the seismograms should record accurate time. Errors may be due either to errors in the clock or to the methods of recording the time. It is to be supposed that in most observatories the error of the time-marking clock is pretty accurately known, but in some cases it seems almost impossible to escape the conviction that sufficient care has not been given to this subject.

The time marks are sometimes made by the recording point itself, or by an eclipse of the record in the case of instruments registering photographically. Neither of these methods introduces any error. If instruments record the time by special devices marking on the paper, either very close to the record or off to the side, a correction must then be made for "parallax/" or the distance between the recording point and the time-marking point. Frequently the pendulum is slightly out of the medial position of equilibrium, and the recording point is displaced to the side; the value of the parallax then changes and some special care is needed to avoid introducing an error in the determination of the time. When the time marks are made at the side of the record, 5 or 10 cm. from the recording point, it is very difficult to carry over the time from them to the record without making an error.

*Undamped instruments.* — The larger number of instruments in use are not damped. The effect of this is to cause a very uneven magnifying-power for vibrations of different periods. This is shown clearly in fig. 47, page 173, where the magnifying power of undamped instruments is seen to increase rapidly with the period of the waves, reaching infinity when this period equals that of the pendulum; and it then diminishes again with longer periods. It is evident, therefore, that an undamped instrument will not accurately reflect the character of the disturbance, but will unduly magnify the vibrations whose periods approach concordance with its own. There are numerous examples of this in the seismograms of the California earthquake. When the amplitude of the recording point has gone beyond the limits of the instrument it has almost invariably been due to abnormally high magnifying powers, caused by concordance of periods, and therefore it does not correspond necessarily, or even usually, with the time of greatest earth movements at the recording station. For instance, Porto d'Ischia and Grande Sentinella, within a few kilometers of each other, have picked out and emphasized waves of different periods.

With undamped instruments it is impossible to determine the magnifying power when the periods of the vibration and the pendulum approach each other; it can only be done satisfactorily when the wave period is less than half or greater than 1.3 times that of the pendulum. As many instruments have periods lying between 15 and 20 seconds, which correspond to the periods occurring during the principal part, we are frequently unable to determine their magnifying power and the true amount of the disturbance. Long-period instruments would give better results for short-period vibrations, and *vice versa*; but the magnifying power of short-period instruments for long periods is very greatly reduced. For instance, the Vicentini pendulum at Manila has a mechanical magnifying power of 100. Its period was 2.4 seconds during the strong motion; the period of the waves was 25 seconds; and the actual magnifying power of the instrument for these waves was a little less than 1.

*Damped instruments.* — Of the instruments which were damped the majority were not damped enough. There are two great advantages in strong damping. The pendulum has a more uniform magnifying power for waves of different periods, and it takes up the true movement more quickly. The curves in fig. 47 show the variations in magnifying powers for different periods and for different degrees of damping. Where the damping is insufficient there is a distortion of the record, as in the case of undamped instruments, but to a less degree. It will be noticed that when the damping ratio is 8 : 1 the magnifying power is nearly constant for all periods shorter than that of the pendulum itself. For longer vibration periods the magnifying power gradually diminishes, but not excessively. When the vibration period is twice as long as that of the pendulum the magnifying power is about 0.8 as great as it would be for an undamped pendulum; and for periods longer still the magnifying power becomes more nearly equal to that of an undamped instrument.

With the damping ratio mentioned the free movement of the pendulum dies out very rapidly. If the pendulum is displaced 64 mm. and allowed to swing freely its amplitude will die down to 1 mm. after one whole vibration. Therefore the free movement of the pendulum will always disappear rapidly, and it will record pretty closely the true movement of the ground. Prince Galitzin advocates "dead-beat" instruments, where the damping is in the proportion 8 : 1. Under this heavy damping he has shown by experiment that the free movement disappears immediately and the pendulum follows very closely the movement of the ground; but the curve in fig. 47 shows that the magnifying power is not constant, but varies continuously for different periods, and therefore a calculation must always be made before we can compare the relative amplitudes in different parts of the record. It seems to me therefore that the most advisable damping ratio is 8 : 1.

*Period of the pendulum.* — If the vibrations have a much longer period than the pendulum, the magnifying power of the instrument is greatly reduced. The advantage of long periods in undamped pendulums is that they hold up the magnifying power for long-period waves. For waves of very short period there is no advantage in giving a long period to the pendulum. For instance, other things being equal, a pendulum with a period of 10 seconds and one with a period of 60 seconds would have practically the same magnifying power for waves whose period was 1 second.

We have seen that when the instrument is damped in the ratio of 8 : 1 the magnifying power varies little for periods up to that of the pendulum; and, therefore, the longer the latter the greater the range over which the magnifying power will be practically constant. A pendulum whose period is 30 seconds and which is damped in this ratio will give a very correct record of the relative amplitudes in all parts of the seismogram; for waves having a longer period than this are not very frequent.

*Magnifying power for short periods.* — Among the instruments which recorded the California earthquake magnifying powers for very short periods of 2 or 3, 6 or 7, 10, 15, 25, 100, and more, are found. The majority of those with low magnifying powers gave unsatisfactory determinations of the beginning of the shock, even at stations less than 90° distant; and for greater distances than this the beginning in general was not recorded at all. We have been unable to determine the time of the arrival of the beginning of the shock at the very distant stations, as they are all provided with low magnifying instruments. This is most unfortunate, for it is true not only in the case of the California earthquake but of all other shocks whose times and origins are accurately known; and therefore our knowledge of the velocity of propagation to very great distances is still quite vague. To get satisfactory records of earthquakes at distances more than 100° it is necessary to have instruments with magnifying powers of at least 100.

*Time scale.* — A great variety of time scales were used, from 1 mm. to the minute, or even less, up to 15 mm. to the minute; and in one case, at Göttingen, the scale was 60 mm. to the minute. The advantage of the open time scale is that individual vibrations are recorded, making it possible to determine their period and the magnifying power of the instrument for them; and the characteristics of the motion can be seen. This can not be done on seismograms with small time scales. On the other hand, when the movement begins very gently it is extremely difficult, on the open time scale, to determine where the slight waves in the line begin; but they would appear much more clearly on seismograms with small time scales. Wherever the magnifying power is sufficiently great there is no difficulty in determining the time of the beginning, and the advantage of a time scale of 10 or 15 mm. to the minute, in permitting the period of the vibration to be determined, is very great.

*Identification of the phases on the seismograms.* — The seismograms made by different instruments differ greatly among themselves, and it is very often extremely difficult to decide exactly where a particular phase begins. Where the magnifying power is sufficiently large this difficulty is not serious for the first and second preliminary tremors, but it often is for the regular waves and the subsequent phases. Where the magnifying power is small there is great difficulty in deciding upon the time of the beginning of the first preliminary tremors. It is therefore of very great importance, in studying the propagation of an earthquake disturbance, to have copies of the seismograms themselves, and not merely the recorded times as determined by the directors in charge of the instruments. For without doubt, different persons examining single seismograms, without comparison with others, would frequently take different parts of the movement to represent the beginning of a particular phase.

APPENDIX  
THEORY OF THE SEISMOGRAPH



## THEOEY OF THE SEISMOGRAPH.

---

### INTRODUCTION.

IN the early development of seismographs the attempt was made to produce a "steady point"; that is, a point that will remain at rest when the earth is set in motion by an earthquake. If then the relative motion of the "steady point" and the earth were recorded, we should have the actual movement of the earth. The "steady point" must be supported against gravity, and therefore all seismographs must consist of a support connected with the earth and moving with it, and a mass, held up by the support in such a manner that it will partake as slightly as possible of the latter's movements; let us call this portion the "pendulum." We must also have a method of recording the motion of the pendulum relative to the support. If the pendulum were exactly in neutral equilibrium for any movement of the support, we should have a truly "steady point," but this can not be realized; a movement of the support exerts forces on the pendulum which set it in motion, and the problem therefore presents itself: to determine the actual movement of the support from the movement of the pendulum relative to the support. The only possible way to do this is to analyze this relative movement, and thru the laws of mechanics work out the movement of the support. We must therefore develop the mechanical theory of the instrument.

Let us first note that all movements can be broken up into a displacement and a rotation; and these can be resolved into three component displacements parallel to three axes at right angles to each other, and three rotations around these axes; and therefore the instruments must be made to record the three displacements and the three rotations in order completely to determine the movement. We shall see that instruments have not been made which will be only affected by one component of the motion, but in many cases the other components may be relatively so unimportant that they may be neglected; or by means of several instruments, we can, by elimination, determine the several components. Earthquake disturbances are propagated as elastic waves of compression or distortion; and even at a very short distance from the origin, the movements of the earth-particles are vibrations about their positions of equilibrium. Surface-waves also exist, in the propagation of which gravity does not play a part.

In the immediate neighborhood of severe earthquakes the vibratory displacements maybe measured by centimeters, but at a distance of 1,000 km. or more the displacements are of the order of millimeters, a displacement of 5 mm. being a very large one; and the horizontal and vertical displacements are of the same general' order. Up to the present our instruments have not separated the linear displacements from the rotations, but we can calculate what the rotations should be with given linear displacements, as follows.

### ROTATIONS DUE TO EARTH WAVES.

Let us first take the case of a simple harmonic wave where the movement of the particles is transverse to the direction of propagation; the equation is

$$y = A \sin 2\pi(j^{\wedge}-ft) \quad (1)$$

$t$ ,



where

$y$  is the variable displacement of the earth particles,  
 $A$  the maximum displacement or amplitude,  
 $t$  the time,  
 $x$  the distance along the direction of propagation,  
 $P$  the period of vibration,  
 $\lambda$  the wave length.

This represents a wave traveling in the positive direction of  $x$ ; the displacement  $y$  may be in any direction perpendicular to  $x$ , and in general it may be broken up into vertical and horizontal components. In figure 32, let  $x$  be the direction of propagation, and  $y$  may be

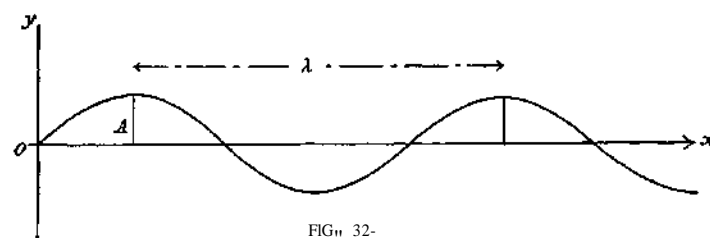

FIG. 32.

either vertical or horizontal; since all the earth particles move parallel to  $y$ , a line in this direction is not rotated at all; whereas a line parallel to  $x$  is made to assume the wave form, and its elements experience the maximum rotation. The tangent of the angle which an element of the line makes with the axis of  $x$  is given by the difference in the displacements of two neighboring points divided by their distance apart, *i.e.*, by  $dy/dx$ ; but

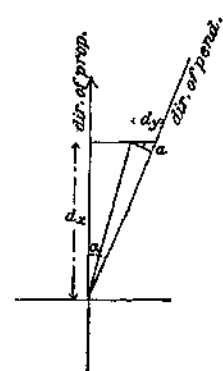

FIG. 33.

$$\frac{dy}{dx} = 2\pi \frac{A}{\lambda} \cos 2\pi \left( \frac{t}{P} - \frac{x}{\lambda} \right) \quad (2)$$

and its maximum value is  $2\pi A/\lambda$ . If  $v$  is the velocity of propagation,  $\lambda = vP$ . The waves of largest amplitude have a velocity of about 3.3 km. per second, and a period of 15 to 20 seconds; and hence a wave length of from 50 to 66 km. If we take  $A = 5$  mm., which is a very large amplitude, and  $\lambda = 66$  km., we find  $2\pi A/\lambda = 6.3 \times 5/66 \times 10^8 = \text{about } 5 \times 10^{-7}$  or one-tenth sec. arc. As small as this angle is, the most sensitive instruments are capable of measuring it, provided the rotation is around a horizontal and not the vertical axis. If two horizontal pendulums were supported by the

solid rock and placed one with the beam pointing in the direction of the propagation of the wave, and the other at right angles to it, then if the displacements were horizontal, that is, if the rotation was around a vertical axis, the first pendulum would suffer a slight relative rotation, but the second one would not. If, however, the displacements were vertical, and the rotation around a horizontal axis, the second pendulum would be displaced and the first would not.

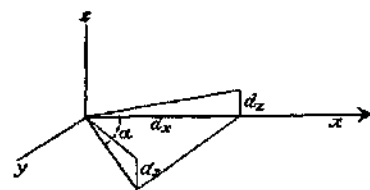

FIG. 34.

In the more general case where the direction of propagation makes an angle  $a$  with the direction of the horizontal pendulum we find the relative rotation of the pendulum for horizontal displacements to be  $\cos^2 a \cdot dy/dx$ , obtained by dividing  $\cos a \cdot dy$  by the length of the line; *i.e.*, by  $dx/\cos a$ , as shown in figure 33. If we had a second pendulum at right angles to the first, the amount of its relative rotation would be  $\sin^2 a \cdot dy/dx$ , and the direction of the 2 rotations would always be the same. In the case of vertical displacements the rotation of a horizontal line making an angle  $a$  with the direction of

propagation is  $\cos \alpha \cdot dy/dx$ , as will readily appear from figure 34. A line making a vertical angle  $\alpha$  with the horizontal direction of propagation would be turned thru an angle  $\cos^2 \alpha \cdot dy/dx$ , but this line does not interest us, nor does the corresponding line in the case of horizontal displacements, which would have a rotation of  $\cos \alpha \cdot dy/dx$ .

These conclusions depend on the assumption that the support of the seismographs has exactly the same motion as the underlying rock, or that the column supporting the pendulum is fastened rigidly to the rock; if, however, the seismograph rests on a pier, even tho it be connected rigidly with the solid rock, the case is different. The movement is communicated to the base of the pier, and as its sides are subjected to no constraining forces, the top of the pier, in the case of horizontal displacements, would probably rotate around a vertical axis nearly like a rigid body, thru an angle equal to the average rotation of all lines in its base; that is, thru an angle  $\mu/A$ , such that

$$\mu = \frac{1}{A} \int_0^{2\pi} \frac{2\pi A}{\lambda} \cos^2 \alpha \cdot d\alpha = \frac{1}{2} \frac{2\pi A}{A} \quad (3)$$

or half the maximum rotation in the solid rock. We assume that the natural period of the pier for rotational vibrations is so much shorter than the period of the earthquake wave that it does not exert an appreciable influence on the amount of the rotation; this assumption seems entirely justified.

In the case of vertical displacements the pier would be tilted thru an angle equal to the tilt of the rock, but its top would also have quite a large linear displacement. If, however, the pier were very long, its period might be comparable to that of the shorter earthquake waves, and the instrument would record movements which would be a combination of the movements of the ground with the proper movements of the pier. It is probable that the movements of high chimneys and tall buildings would be materially affected by their natural periods of vibration.

Let us now consider waves of condensation, like sound waves, where the direction of the displacement,  $f$ , is the same as that of propagation,  $x$ ; the equation of the wave will still have the same form as heretofore. A line in the direction of propagation or at right angles to it, horizontal or vertical, will have no rotation; a horizontal line making an angle  $\alpha$  with  $x$  will suffer a difference of displacement of its two ends equal to  $d\delta \sin \alpha$ , or  $d\delta \cos \alpha$  at right angles to its length; its length is  $dx/\cos \alpha$ ; therefore its rotation is  $\sin \alpha \cos \alpha \cdot dg/dx$ ; the maximum value of this is  $rrA/x$ , when  $\alpha = 45^\circ$  and when  $dg/dx$  is a maximum. This is a rotation around the vertical axis. A line making an angle  $\alpha$  on the opposite side of the line of propagation is rotated in the opposite direction; it is probable that the top of the pier would not rotate at all about the vertical, when the base is subjected to this kind of motion. Observers have not so far succeeded in directly measuring rotations; and as we should expect them to be extremely small, we shall so consider them until further evidence shows them to be larger.

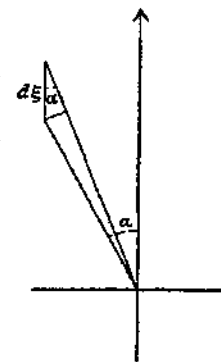

FIG. 35.

#### FORMS OF SEISMOGRAPHS.

The forms of instruments which have proved practical for recording very small disturbances are: the ordinary pendulum, the horizontal pendulum, and the inverted pendulum. The first form is too familiar to need any explanation; the second is a frame or a bar carrying a heavy mass, supported at two points nearly in a vertical line, as a door is supported by its hinges; so that its position is affected by a small displacement of the support at right angles to the direction toward which it points; the inverted pendu-

lum is a heavy mass whose center of gravity is vertically above the point of support; some additional forces must be applied in order to keep it in stable equilibrium in this position; these forces are usually supplied by springs connecting the upper part of the mass and the support.

#### REGISTRATION.

There are two principal methods of magnifying and registering the relative movements, the photographic and the mechanical. It is to be noticed that these relative movements are all of the nature of rotations of the pendulum about a point or a line of the support. The photographic method of registering may be divided into two kinds, the optical and the direct. In the optical method a beam of light from a stationary point is reflected from a mirror on the pendulum and concentrated on a moving sheet of photographic paper which is afterwards developed. Time marks are made by periodically eclipsing the light. The magnifying power depends on the distance of the recording paper from the mirror. In the direct method the light is reflected through a longitudinal slit in a diaphragm on the end of the pendulum's beam and a transverse slit in the top of a box, to the moving photographic paper below. As long as the pendulum is still, a straight line is recorded on the paper, but when the pendulum swings, the line is shifted from side to side. The magnifying power depends on the ratio of the length of the beam to the distance of the center of oscillation from the axis of rotation. In the mechanical method of registering the record is made by a pen on white paper or by a stylus on smoked paper. The marking point may be fastened directly to the pendulum or may be connected with it thru one or more multiplying levers.<sup>1</sup>

#### THE MATHEMATICAL THEORY.

The mathematical theory of seismographs has been written by Dr. W. Schliiter,<sup>2</sup> E. Wiechert,<sup>3</sup> Prince B. Galitzin,<sup>4</sup> Gen. H. Pomerantzeff,<sup>5</sup> Professor O. Backlund,<sup>6</sup> Dr. M. Contarini,<sup>7</sup> and Dr. M. P. Rudski,<sup>8</sup> but up to the present the general theory has not been written in English. Messrs. Perry and Ayrton, however, published an important paper in 1879,<sup>9</sup> in which they developed the mathematical theory of a heavy mass suspended by springs in a box supposed to move with the earth. They emphasized the fact that the actual motion of the mass is made up of that of the earth and of its proper vibration; they showed the influence of damping and the relation between the relative movement and the motion of the earth. This paper seems to have been overlooked and is not referred to by later writers on the theory.

<sup>1</sup> It is not desirable here to give details of construction. They will be found in Milne's Earthquakes and Seismology; in Button's Earthquakes, in Sieberg's Erdbebenkunde, and in the original descriptions in memoirs of scientific societies. Dr. It. Ehlert describes many forms of instruments in Gerland's Beiträge zur Geophysik, 1895-1898, vol. III, pp. 350-475.

<sup>2</sup> Schwingungsart und Weg der Erdbebenwellen. Gerland's Beiträge zur Geophysik, 1903, vol. V, pp. 314-360, 401-466.

<sup>3</sup> Theorie der automatischen Seismographen. Abhand. Kön. Gesells. Wissen. Göttingen, Math. Phys. Kl. 1902-1903, Bd. II, pp. 1-128.

<sup>4</sup> Ueber Seismometrische Beobachtungen. Acad. Imp. Sciences. St. Petersburg, 1902. Comptes Rendus Commission Seismique Permanente. Liv. 1, pp. 101-183. Zur Methodik der Seismometrischen Beobachtungen. Same, 1903. T. I. Liv. 3, pp. 1-112. Ueber die Methode zur Beobachtungen von Neigungswellen. Same, 1905, T. II. Liv. 2, pp. 1-144. Die Electromagnetische Itcgistrirmethode, Same, 1907, T. III. Liv. 1, pp. 1-106.

<sup>5</sup> In Russian, Same, pp. 185-208.

<sup>6</sup> Formeln für das Horizontalpendel. Same, pp. 210-213.

<sup>7</sup> Rend. d. R. Acad. d. Linn. Cl. Sc. iis. math. e. nat., 1903, vol. XII, pp. 507-515, 609-616.

<sup>8</sup> Ueber die Bewerung des Horizontalpendels. Gerland's Beiträge zur Geophysik, 1904, vol. VI, pp. 138-155.

<sup>9</sup> On a Neglected Principle that may be employed in Earthquake Measurements. Phil. Mag., 1879, vol. VIII, pp. 30-50.

Dr. Schliiter's work was undertaken to determine if the movements of seismographs due to distant earthquakes were caused by linear displacements or by tilts; and he develops the theory for these two kinds of motion separately. He discusses the effect of damping and shows the relation between the movement of the earth and that of the seismograph.

Professor Wiechert begins by giving the theory of the ordinary pendulum in a very simple way, which does not, however, show the degree of approximation made; he then develops the general theory of seismographs without considering specifically the characteristics of each form. An extremely valuable part of the memoir is the study of the solid and viscous friction and their influence on the movement of the pendulums; also the relation between the amplitude of the pendulum relative to the support and the amplitude of the support, when the latter is moving in a simple harmonic vibration, for various values of the ratio of the period of vibration of the support and the natural period of the pendulum, and for various degrees of damping.

Prince Galitzin treats many forms of seismographs with considerable fullness. He develops the equations through Lagrange's equations and shows what terms are neglected and the degree of approximation secured. The physical origin of certain terms in his equations are not evident, and he treats his pendulums as mathematical pendulums, that is, as though the mass were concentrated at the center of oscillation; certain terms which contain the moment of inertia about the center of gravity do not appear in his equations; this is unimportant as they are in general negligible. Prince Galitzin has also developed a method of electromagnetic recording, and has given the theory of the instrument. This instrument offers some special advantages, but it has not yet come into general use. An important part of Prince Galitzin's work consists of an experimental verification of the theory by means of a moving platform, which imitates the movements produced by distant earthquakes.

Professor Backlund starts from Euler's equation and obtains the equation of the horizontal pendulum under disturbance, but he does not consider either viscous or solid friction.

Dr. M. Contarini treats the seismograph as a series of connected links, and develops the theory in symbolic form.

Dr. Rudski develops the equations of the horizontal pendulum through Lagrange's equations, retaining quantities of the second order. Under these conditions he finds that in the case of periodic movements of the ground, the terms containing the damped free period of the pendulum are no longer periodic. In cases where the damping is large or the movement of the pendulum small, this peculiarity is unimportant.

In the following pages we shall develop the equations of relative motion of the pendulum from the two fundamental laws; namely, the motion of the center of gravity, and Euler's equations for angular accelerations about moving axes. We shall see the order of the terms neglected, and the physical origin of the terms in our resulting equations will be evident. We shall begin with the horizontal pendulum, as the lever used for magnifying the motion with ordinary mechanical registration is itself a horizontal pendulum and the equation of its motion must supply terms in our resultant equations. We shall also assume an arbitrary position for the origin of coördinates, and determine what position of this origin will give the simplest equation; we shall find this to be the center of gravity of the pendulum in its undisturbed position. Although I have followed a different route in developing the equation of the seismograph from those followed by the investigators mentioned, I wish to acknowledge my indebtedness to them for the guidance I have received from **their** researches.

## THE HORIZONTAL PENDULUM.

There are three points of the pendulum on which, forces act, namely, the center of gravity and the two points of support. We shall call the line joining the two latter points the *axis of rotation*. The forces at the points of support may be replaced by a single force  $F$ , acting at the point of intersection of the axis of rotation with the perpendicular on it from the center of gravity of the pendulum, and a couple. In the Zöllner form of suspension this point is not fixed relatively to the pendulum, and therefore the theory here given does not apply to the Zöllner suspension; see further, page 179. The force at the center of gravity is simply gravity acting vertically downwards.

Let us refer the position of the pendulum to a set of rectangular coördinates fixed in space whose origin is at  $O$  and whose positive directions are shown in figure 36. When

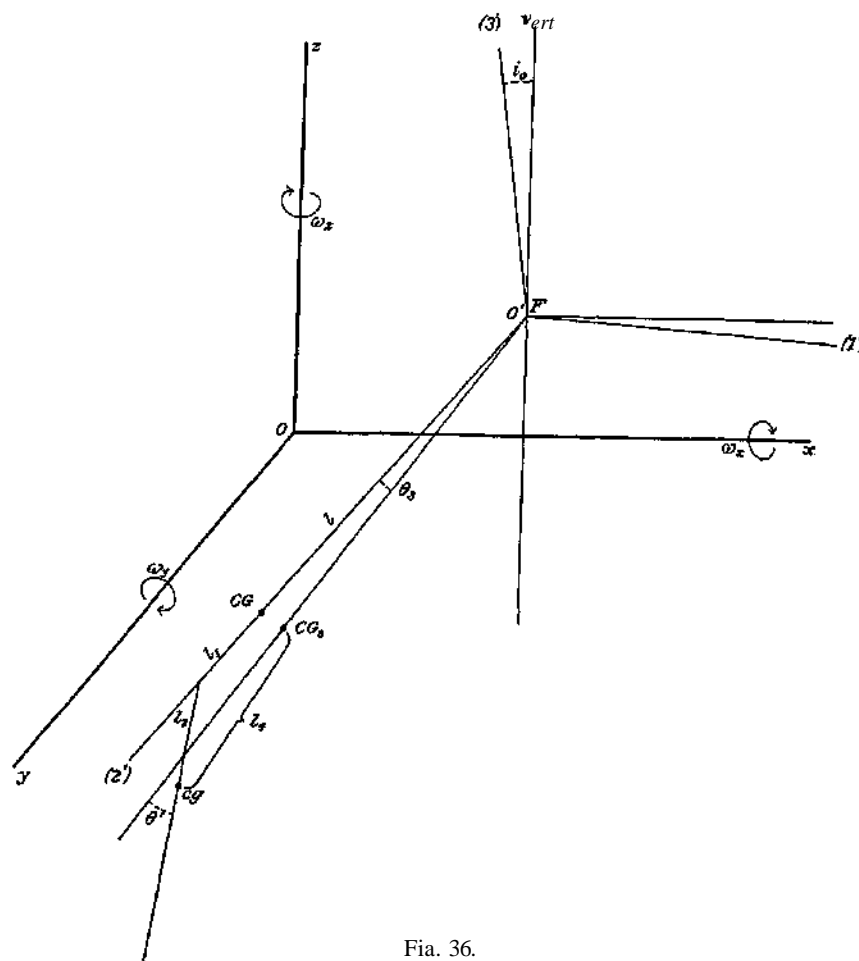

Fig. 36.

the pendulum is at rest, let it lie in a plane parallel to the plane of  $yz$ , and let it point in the direction of  $y$ . Let  $CG_0$  refer to the original undisturbed position of the center of gravity of the pendulum;  $CG$ , the position which this point would take during the disturbance if it were rigidly connected with the support, and  $CG_s$  its actual position at any time.

In figure 36, let

$i_0$ , be the inclination of the axis of rotation to the vertical in the undisturbed condition;

- $i$ , the inclination during the disturbance;  
 $\theta$ , the angular displacement of the  $CG$  relative to the support, the positive direction being the same as that of  $a_{>z}$ ;  
 $l$ , the perpendicular distance from the  $CG$  to the axis of rotation at  $0'$ ;  
 $X, Y, Z$ , the absolute coördinates of  $0'$  before the disturbance;  
 $x, y, z$ , the absolute coördinates of the  $CG$  at any time;  
 $F$ , the force applied at  $0'$ ;  
 $F_x, F_y, F_z$  } its components parallel to the fixed axes and to the moving axes, respectively.  
 $F_1, F_2, F_3$  }  
 $f_x, f_y, f_z$  } the components of the force exerted on the pendulum by the indicator;  
 $f_1, f_2, f_3$  }  
 $M$ , the mass of the pendulum;  
 $I_1, I_2, I_3$ , the moments of inertia of the pendulum about the principal axes of inertia through the  $CG$ ;  
 $\xi, \nu, \zeta$ , the linear displacements of the support due to the disturbance;  
 $\alpha_x, \alpha_y, \alpha_z$  } the angular displacements around the axes, due to the disturbance, the positive directions being indicated in the figure.  
 $\alpha_v, \alpha_w, \alpha_s$  }

For the sake of clearness the displacements of the support are not shown in the figure, but they can easily be imagined.

The linear accelerations of the  $CG$  are given by the equations

$$M \ddot{x} = F_x + f_x \quad M \ddot{y} = F_y + f_y \quad M \ddot{z} = F_z - Mg \quad (4)$$

In order to see exactly what approximations we make, we must use Euler's equations for moving axes to determine the angular accelerations; the motion is referred to the instantaneous position of the 3 principal axes of inertia thru the  $CG$ , which we have called (1) (2) and (3) respectively; as we only observe the rotation around (3) we may neglect the equations referring to the other axes; the equation is

$$I_3 \frac{d^2 \mu}{dt^2} - (I_1 - I_2) \frac{d\omega_1}{dt} \frac{d\omega_2}{dt} = C_3 \quad (5)$$

where  $p$  is the absolute angular acceleration around the instantaneous position of the axis (3), and  $C_3$  is the moment of all forces around this axis. As the pendulum has no relative motion around the axes (1) and (2), its angular velocities around their instantaneous positions are the same as those of the support. Since the support is supposed to move with the underlying rock, its angular displacement will be the same as that of the rock, and will be given by equation (2). Its angular velocity will be obtained by differentiating this equation with respect to the time, we thus find:

$$\frac{d\omega_1}{dt} (\max) = \frac{(2\pi)^2 A}{\lambda P} \quad (6)$$

and with the values there used:  $A = 5$  mm.,  $P = 20$  sees.;  $X^* = 66$  km., this becomes about  $3 \times 10^{-7}$ ; and  $d < o < Jdt$  has a value of the same order. We may write (as we shall see further on)

$$\mu = \odot \cos \left( \frac{2\pi}{P} t \right); \quad \frac{d^2 \mu}{dt^2} (\max) = \left( \frac{2\pi}{P} \right)^2 \odot \quad (7)$$

making  $P = 20$  sees, and  $\odot = 0.005$ , which is probably a smaller value than it would have under the assumed disturbance, we find the maximum value of the relative angular acceleration of the pendulum to be about  $5 \times 10^{-4}$ , a quantity far larger than the product of the two angular velocities given above. We may, therefore, without appreciable error, neglect the second term of equation (5).

The reactions of the support have been replaced by a single force  $F$  applied at  $O'$  and a couple. The forces of the couple both pass thru the axis of rotation and therefore can not have a component around it, or around a parallel axis thru the  $CG$ . Of the components of  $F$ ,  $F\%$  passes through the  $CG$ ;  $F_3$  is parallel with (3), and therefore  $F_x$  alone is capable of exerting a moment around (3). Similarly only the  $f_x$  component of / can exert a moment around (3). If the latter force is exerted at a point distant  $l_x$  from  $O'$ , we find

$$C_s = F_l l - f_l (l_1 - l) \quad (8)$$

Let us replace  $d^2\dot{f}_i$  by  $d^2(6 + a_g)$ , which expresses the angular acceleration in terms of the acceleration of the pendulum relative to the support, and the acceleration of the support; with these substitutions the equation of angular acceleration (5) becomes

$$I_1 \frac{d^2(\theta + \omega_s)}{dt^2} = F_l - f_l (l_1 - l) \quad (9)$$

We must now replace  $F_l$  by its value in terms of the resolved parts of  $F_x$ ,  $F_y$ ,  $F_z$  in the direction of (1), and then the values of these latter quantities must be obtained from equation (4).

We have

$$F_l = F_x \cos(x, 1) + F_y \cos(y, 1) + F_z \cos(z, 1) \quad (10)$$

Since the rotations are the same for all points, we can determine the cosines of the angles in the above equation, by assuming a sphere of unit radius with center at  $O'$ , and determining the displacements of the axes on its surface as a result of the rotations ( $\omega$ 's) and the relative angular displacement ( $\theta$ ). These values follow directly from figure ^7, where the points represent the intersections of the axes with the surface of the sphere and the lines represent the displacements of these points.

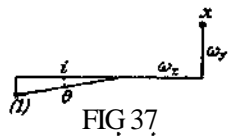

FIG 37

$$\begin{aligned} \cos(x, 1) &= \cos(\omega_2 + \theta) = 1 - \frac{\omega_2^2}{2} \\ \cos(y, 1) &= \sin\left\{\omega_x + \theta\left(1 - \frac{\omega_2^2}{2}\right)\right\} = \omega_x + \theta \\ \cos(z, 1) &= -\sin(\omega_j + \theta) = -(\omega_y + \theta) \end{aligned} \quad (11)$$

All the angles are small, and  $i$  and  $\theta$  are considerably larger than the  $\omega$ 's; we have therefore neglected squares of the  $\omega$ 's, products of  $\omega$ 's and  $\theta$ , and  $\theta^2$ ; but  $i\theta$  is an important term in our equation; and since  $\theta^2$  is of the same order, these terms must be retained.

Substituting the values of these cosines and the values of  $F_x$ ,  $F_y$ ,  $F_z$  from equations (4), in equation (10) we get

$$F_l = \left(M \frac{d^2x}{dt^2} - f_x\right) \left(1 - \frac{\theta^2}{2}\right) + \left(M \frac{d^2y}{dt^2} - f_y\right) (\omega_x + \theta) - \left(M \frac{d^2z}{dt^2} + Mg\right) (\omega_y + \theta) \quad (12)$$

The coordinates of  $CG_0$  are  $X$ ,  $Y+l$ ,  $Z-il$ ; the coordinates of  $CG_S$ , during the disturbance, are

$$\begin{aligned} X &= X + A + (Z - il) \omega_x - (Y + l) \omega_y \\ Y &= Y + l + X \omega_x - (Z - il) \omega_y \\ Z &= Z - il + (Y + l) \omega_x - X \omega_y \end{aligned} \quad (13)$$

and the coordinates of  $CG$  during the disturbance are

$$\begin{aligned} x &= X + X + (Z - H) \omega_x - (Y + l) \omega_y - i\theta \\ y &= Y + l + X \omega_x - (Z - il) \omega_y \\ z &= Z - il + (Y + l) \omega_x - X \omega_y \end{aligned} \quad (14)$$

The rotations are so small that we may neglect the order in which they are effected, and their coefficients may be considered constants. Differentiating, we get

$$\begin{aligned} \frac{d^2x}{dt^2} - \frac{d^2\epsilon}{dt^2} &= (Y + l) \frac{d^2\omega_x}{dt^2} - \frac{d^2P}{dt^2} \\ \frac{d^2y}{dt^2} &= \frac{d^2\eta}{dt^2} + X \frac{d^2\omega_x}{dt^2} - (Z - il) \frac{d^2\omega_z}{dt^2} \\ \frac{d^2z}{dt^2} &= \frac{d^2\xi}{dt^2} + (Y + l) \frac{d^2\omega_x}{dt^2} - X \frac{d^2\omega_z}{dt^2} + g \end{aligned} \quad (15)$$

Introducing these values in equation (12), and the value of  $F_x$  thus obtained in equation (9) and writing  $I_8 + Ml^2 = I_{(3)}$ , the moment inertia around the axis of rotation, we get,

$$\begin{aligned} I_{(3)} \frac{d^2\theta}{dt^2} + I_8 \frac{d^2\omega_3}{dt^2} &= Ml \left[ \left\{ \frac{d^2\xi}{dt^2} + (Z - il) \frac{d^2\omega_x}{dt^2} - (Y + l) \frac{d^2\omega_z}{dt^2} - \frac{f_z l_1}{Ml} \right\} \left( 1 - \frac{\theta^2}{2} \right) \right. \\ &\quad + \left. \left\{ \frac{d^2\eta}{dt^2} + X \frac{d^2\omega_x}{dt^2} - (Z - il) \frac{d^2\omega_z}{dt^2} \right\} (\omega_x + \theta) \right. \\ &\quad \left. - \left\{ \frac{d^2\xi}{dt^2} + (Y + l) \frac{d^2\omega_x}{dt^2} - X \frac{d^2\omega_z}{dt^2} + g \right\} i \left( \frac{\omega_x}{i} + \theta \right) \right] \end{aligned} \quad (16)$$

The force  $f_z$  is small; and on account of friction between the pendulum and the indicator, its direction is not accurately known, but as the friction and the angular displacements are small, it is nearly at right angles to both the pendulum and the indicator; we have therefore replaced  $f_i$  in equation (9) by  $f_x (1 - \theta^2/2)$  and have neglected the term  $f_y (\omega_y + \theta)$  in obtaining equation (16). This is the general equation of the horizontal pendulum seismograph, within the approximations mentioned. The successive lines of the second member give the moments around the axis (3) due to forces parallel to the axes of  $x$ ,  $y$ , and  $z$  respectively; (the term  $MPd^2B/dt^2$ , which has been combined in the first term of the first member, should be restored to the first line of the second member to make the statement strictly true) and the origin of the force represented by each term in the equation is evident.

This equation can be greatly simplified by a proper choice of the origin of coördinates; if we place the origin at  $O'$ , we have  $X = Y = Z = 0$ , and the equation becomes

$$\begin{aligned} I_{(3)} \frac{d^2\theta}{dt^2} + I_8 \frac{d^2\omega_3}{dt^2} &= Ml \left[ \left\{ \frac{d^2\xi}{dt^2} - il \frac{d^2\omega_x}{dt^2} + l \frac{d^2\omega_z}{dt^2} - \frac{f_z l_1}{Ml} \right\} \left( 1 - \frac{\theta^2}{2} \right) \right. \\ &\quad \left. + \left\{ \frac{d^2\eta}{dt^2} + il \frac{d^2\omega_x}{dt^2} \right\} (\omega_x + \theta) - \left\{ \frac{d^2\xi}{dt^2} + l \frac{d^2\omega_z}{dt^2} + g \right\} i \left( \frac{\omega_x}{i} + \theta \right) \right] \end{aligned} \quad (17)$$

On putting  $l_8 = 0$ , omitting  $\theta^2/2$ ,  $f_z l_1$  and  $l \frac{d^2\omega_z}{dt^2}$ , and making the proper changes of notation, this becomes the equation No. 86 of Prince Galitzin.<sup>1</sup> Equation (16) can be simplified still more by placing the origin at  $CG_Q$ ; then  $X = Y + l = Z - il = 0$ , and it becomes

$$I_{(3)} \frac{d^2\theta}{dt^2} + I_8 \frac{d^2\omega_3}{dt^2} = Ml \left[ \left( \frac{d^2\xi}{dt^2} - \frac{f_z l_1}{Ml} \right) \left( 1 - \frac{\theta^2}{2} \right) + \frac{d^2\eta}{dt^2} (\omega_x + \theta) - \left( \frac{d^2\xi}{dt^2} + g \right) i \left( \frac{\omega_x}{i} + \theta \right) \right] \quad (18)$$

It is evident that this equation can not be simplified further without omitting some of its terms. Referring to the equation of a wave, equation (1); differentiating twice with respect to  $t$  we find for the maximum value of the acceleration

$$\frac{d^2\eta}{dt^2} (max) = \left( \frac{2\pi}{P} \right)^2 A \quad (19)$$

<sup>1</sup> Ueber Seismom. Beobachtungen.. Acad. Imp. d. Sci. St. Petersburg. G. R. Com. Sisraique Perma-  
nent©. 1902, Liv. I, p. 142.



with  $P = 20$  sees, and  $.4 = 5$  mm., this has a value of about 0.5 mm. per sec. per sec. This is the order of the terms  $d^2\theta/dt^2$ ,  $d^2v/dt^2$ ,  $d^2i/dt^2$ ; the last is very small in comparison with  $g$ , which is nearly 10,000 mm. per sec. per sec., and may therefore be neglected.  $\theta^2/2$  is small in comparison with unity, but it is of the same order as  $id$  nevertheless  $d^2i/dt^2$  is so small in comparison with  $g$ , that we may neglect  $(\theta^2/2)(d^2i/dt^2)$  also;  $d^2v/dt^2$  is of the same order as  $d^2Z/dt^2$ , but it is multiplied by  $(\omega^2/2)$ , which with some instruments may amount to  $1/6$ ; if the accuracy of our measures is not greater than this, we may omit this term in comparison with  $d^2i/dt^2$ . The product  $f_x(1 - \theta^2/2) = f_y$ . The left-hand member of the equation may be written  $MPd^2d/dt^2 - I_s(d^2\theta/dt^2 - d^2\cos\theta/dt^2)$ ; the omission of  $d^2a/dt^2$  is equivalent to substituting, in the second term, the angular acceleration relative to the support for the absolute angular acceleration. Since the maximum value of  $\omega$  is of the order of  $5 \times 10^{-7}$  and the maximum value of  $\theta$  is of the order of  $5 \times 10^{-3}$ , and since they would have the same period, we find that  $d^2d/dt^2$  would be about 1,000 times as large as  $d^2a/dt^2$ ; and since in general  $I_s$  is much smaller than  $MP$ , it is clear that we make no material mistake in omitting  $d^2a/dt^2$ . Our equation then takes the form

$$I_s \frac{d^2\theta}{dt^2} = Ml \left[ \frac{d^2\xi}{dt^2} - \frac{f_x l}{Ml} - gi \left( \frac{\omega}{i} + \theta \right) \right] \quad (20)$$

In the undisturbed condition the  $CG$  lies in the vertical plane containing the axis of rotation, this axis making a small angle  $i_0$  with the vertical. When the instrument is disturbed the position of equilibrium is in the vertical plane containing the axis of rotation in its disturbed position. Using the same device as on page 152, we see by figure 38

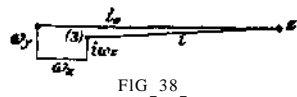

that the angle thru which the plane of equilibrium is turned is  $-(a_y - i\omega_z)/i$ ; but since the support itself is turned about the vertical thru an angle  $a_y$ , the angular displacement of the plane of equilibrium relative to the support is  $-(\omega_z - i\omega_y)/i - a_y$ , which reduces to  $-a_y/i$ . The last term in equation (20) is therefore the moment due to gravity tending to bring the pendulum back to its position of equilibrium, and it is proportional to the angular displacement from the position of equilibrium.

The value of the new angle  $i$ , between the vertical and the axis of rotation, reduces practically to  $i_0 - a_y$ , on account of the small angle thru which the plane of equilibrium has been rotated (see figure 38). Since  $\omega_x$  is of the order  $5 \times 10^{-7}$  and  $i_0$  for the von Rebeur pendulum, where it has a smaller value than for any other instrument, is about 1:700, we see that its value is about  $i:5000$ ; for other instruments it is still smaller; we may omit  $a_y$  and consider that the inclination of the axis of rotation to the vertical has not been changed by the disturbance.

The equation contains  $f_x l$ , the moment due to the reaction between the pendulum and the indicator. Its value can be determined from the equation of the indicator and then substituted in equation (20). The indicator is itself a small, horizontal pendulum and is affected by the disturbance; its general equation will be of the form of equation (16). Let us assume that the axis of rotation of the indicator and its  $cg_0$  lie in the axis of  $y$  thru the  $CG_0$  of the pendulum; the coördinates of the  $cg_0$  then become 0,  $l$ , 0 (see fig. 36); putting these values for  $X$ ,  $Y + l$ ,  $Z - il$ , in equation (16) and writing primes to mark the quantities referring to the indicator, its equation becomes

$$I_s' \frac{d^2\theta'}{dt^2} + I_s' \frac{d^2\omega_z'}{dt^2} = M'l \left[ \frac{d^2\xi'}{dt^2} - \frac{f_x' l'}{M'l'} + \frac{d^2\eta'}{dt^2} (\omega_z + \theta') - \left( \frac{d^2\xi'}{dt^2} + l' \frac{d^2\omega_z'}{dt^2} + g \right) \omega_y' \right] \quad (21)$$

// has a positive sign because the force is applied so that a positive force causes a positive angular acceleration; we have assumed  $i = 0$ , and that the reaction between the

indicator and the pendulum acts at right angles to the former and is equal to its (1) component. These assumptions will not be accurately true, but the quantities involved are small, and no important error will be introduced by them. Even in this form the equation is very complicated, but it can be made very simple by constructing the indicator so that its *eg* shall lie in its axis of rotation, then  $V$  becomes 0, and only one term remains on the right-hand side. In this case  $I_{(s)'} = I_s'$ ; but  $\delta'$  is several times as large as  $\theta$ , so that as shown on page 154 we may omit  $\frac{1}{3} \delta'^2 (a/c \&^2)$ , and the equation of the indicator takes the simple form

$$V^{\wedge} = I A \quad (22)$$

With the *eg* in the axis of rotation it makes no difference where this axis is situated, and the indicator may even be a bent lever without changing its equation; this method of reducing the influence of the indicator is so simple that it should always be followed. In this paper we shall assume that it has been; if it has not we must either take into account the various terms of equation (21) or we must look upon them as unimportant and neglect them.

We have, of course,  $f_i' = -f_i$ ; also  $\delta' = -n_x \delta$ , where  $n^{\wedge} l_j l^{\wedge}$ , and hence  $\delta d/d\delta = -n^{\wedge} O/dt^2$ ; eliminating  $f_x$  from equation (20) by means of equation (22), and making the above substitutions, we get

$$(I_{(s)} + n_1^2 I_3') \ddot{\theta} + \left[ \xi < - \frac{\omega_x}{i} + \delta \right] \dot{\theta} = 0 \quad (23)$$

It will be seen that the moment of inertia of the pendulum is practically increased by  $n_x^2$  times the moment of inertia of the indicator, and this tends to diminish the angular acceleration; whereas the mass of the pendulum which appears on the right side of the equation and tends to increase the acceleration is not affected by the indicator; hence the importance of making the indicator as light as possible. If for the sake of increasing the magnifying power of the pendulum we should add a second lever to be deflected by the first, and if the ratio of the angular deflections of the second and first levers be  $n_v$ , then the effective moment of inertia of the two levers is  $7_{(3)'} + n \ell l_m''$ , and that of the whole system is  $7_{(8)} + w_1^2 / (8)' + n^2 2 l_m''$ . The magnifying power may be increased by a multiplication of levers, the actual deflections of the pendulum are diminished and it may be materially. In the Bosch-Omori 10 kilog. seismograph  $7_{(3)} = 61.6 \times 10^6$  cm.<sup>2</sup>gm.;  $7_{(3)'} = 280$  cm.<sup>2</sup>gm.; and when the magnifying power is 10,  $w_x = 31.3$ ; hence the effective moment of inertia added by the indicator,  $n^{\wedge} I_d'$  equals  $27.5 \times 10^4$ , or  $\frac{1}{225}$ th of  $7_{(3)}$ .

Let us write  $7_{(3)} 4- \mu^* l_j 4- n^{\wedge} n_2^2 l_{is}'' \dots = [7]$ ; also  $[I]/Mt = L$ ; introducing these substitutions in the equation (23) we get

$$\frac{d^2 \theta}{dt^2} - \frac{1}{L} \frac{d^2 \xi}{dt^2} + \frac{g i}{L} \left( \frac{\omega_x}{i} + \theta \right) = 0 \quad (24)$$

We have so far not taken account of friction; but all instruments are subjected both to viscous friction, or damping, proportional and opposite to the velocity, and to solid friction, which has a constant quantitative value, but always opposes the motion; in some cases, special devices are added to increase the damping. Writing  $2 \tau cd \theta / dt$  to represent the damping and  $T p_0$  for the solid friction, the equation becomes

$$f^{\theta} + 2 \tau f - \xi + f(\wedge + e W \theta) = 0 \quad (28)$$

We here assume that the damping is proportional to the velocity relative to the support. This is true where special damping devices are affixed to the support, but in the case

where no special damping is introduced, the viscous friction is largely due to the resistance of the surrounding air, and if this does not move with the support, it will not be proportional to the *relative* velocity, but to some complicated function of the relative and absolute velocities. If the instrument is in a closed room, and the earthquake motion not fast, the air will, to some extent, move with the support, and as the damping, when special devices are not used, is extremely small, we make no material error in putting it proportional to the *relative* velocity.

$\delta$  in the equation refers to the relative angular displacement of the pendulum; if we prefer to deal directly with the relative displacement of the marking point, we can proceed as follows: let  $l$  be the length of the long arm of the last or marking lever, and  $\bar{\delta}$  its angular displacement; multiply the equation (25) throughout by  $\bar{n}l$ , where  $\bar{n} = \frac{71}{1} \cdot 2^{n-3} \cdot \dots$ . If  $a$  is the linear relative displacement of the marking point  $a = \bar{l}\bar{\delta} = \bar{n}l\delta$ ; making these substitutes in the equation it becomes

$$\frac{d^2 a}{dt^2} + 2 \frac{a}{L} + \mathbf{f} + \mathbf{f}' \left( \frac{a}{L} + \mathbf{a} \mathbf{W} \right) = 0 \quad (26)$$

where  $p' = \bar{n}l p_0$ .  $a$  and its derivatives in this equation will have positive or negative signs, according as the number of multiplying levers is odd or even; this will be evident if we suppose the support to have an acceleration in the positive direction; the pendulum will be left behind; and the long end of the first lever will move in the positive direction, that of the second lever in the negative direction, etc. These are the equations of relative motion of the pendulum and of the marking point, and they are the only equations we have from which to deduce the movement of the support. It will be seen that, for the horizontal pendulum with the origin at the  $CG_0$  and to the degree of approximation used, the only displacements of the support which enter are the linear acceleration parallel to the axis of  $x$ , and the rotation around the axis of  $y$ ; but as both enter the equation we are not able to determine the value of either separately. (See, however, page 188.)

For the Milne instrument direct photographic registration is used; if  $l_x$  is the length of the beam from the axis of rotation to the slit for the recording light, then  $a = -l_x \dot{\theta}$ , since  $l_x \dot{\theta}$  and  $a$  are positive in opposite directions; and in equation (26)  $-\bar{n}l$  must be replaced by  $l_x$ . For the von Rebeur-Paschwitz form the optical method of registration is used; if  $D$  is the distance from the mirror on the pendulum to the recording paper, then  $a = -2D\delta$  and  $\bar{n}l$  must be replaced by  $-2D$ .

We see from the equation that 2 pendulums which have the same values of  $\bar{n}$ ,  $L$ ,  $i$ , and  $p_0$  have identical equations, and their movements for the same disturbance would be identical, although they might differ very much in mass and in form; and *vice versa*, in order that 2 pendulums should have identical motions for the same disturbance it is necessary that the constants above should have the same values for the 2 pendulums. This makes it perfectly clear why 2 dissimilar pendulums give such different records of the same disturbance; indeed 2 pendulums made as nearly alike as possible give dissimilar records if they have different values of  $i$ , *i.e.* different periods; or even if they have different values of  $p'$ . This was pointed out in 1899 by Dr. O. Hecker.<sup>1</sup> Two horizontal pendulums of the von Rebeur-Paschwitz type made as nearly alike as possible, mounted side by side, and having the same period of vibration, gave very different records of the same earthquake. The difference was found to be due to differences in the friction at the supporting points. Alterations were made until the friction was the same in the two instruments as shown by the similarity of the dying-out curves of free vibrations. After that the two instruments gave similar records of a disturbance.

<sup>1</sup> Zeit. für Instruamentenkunde, 1899, p. 266.



arises from the fact that we have taken our origin of coördinates at the  $CG_0$  of the pendulum.

If we go back to the equation (18) and eliminate the reaction of the indicator as before, but retain the term containing the angular acceleration about axis (3), we should find in our final equation the terms

$$(J_{(3)} + n^2 I_{(3)'}) \frac{d^2 \theta}{dt^2} + (I_3 + I_3') \frac{d^2 \omega_3}{dt^2}$$

which would be the only important terms in our equation, when a very small but very rapid angular acceleration occurred around axis (3). Integrating, we find

$$O - O_0 = \frac{a + V}{J_{(3)} + n^2 I_{(3)'}} (a - \cos \theta) \quad (30)$$

For the Bosch-Omori pendulum  $J_{(3)}$  is about 30 times  $J_3$ ;  $n^2 I_{(3)'}$  and  $I_3'$  are negligible; we therefore see that the angular displacement of the pendulum would only be about 5V of that of the support around the axis (3).

If, on the other hand, there is a permanent angular displacement about the axis of  $y$ , and no other disturbance, we must have for equilibrium  $\theta = a/nI_{(3)'}$ ; we have neglected the solid friction, which may act to increase or decrease the angle  $\theta$ , or the displacement  $a$ , according as the pendulum reaches its position of equilibrium from one side or the other. We shall see later how the value of  $p'$  affects the result, but neglecting it for the moment, we see that the angular displacement of the pendulum is  $1/i$  times that of the support. Hence  $1/i$  may be taken as the magnification of constant angular displacements around axis of  $y$ . For the Bosch-Omori instrument this is about 70, for the Milne, about 450, and for the von Rebeur-Paschwitz, about 700, when the period of vibration is about 17 seconds. As appears below,  $1/i$  is proportional to  $T_0^2$ .

If there is no disturbance and we neglect friction, equation (26) reduces to the form

$$\frac{d^2 \alpha}{dt^2} + \frac{g}{L} \alpha = 0 \quad (31)$$

whose solution represents a simple harmonic swinging of the pendulum with a period

$$T_0 = 2\pi \sqrt{\frac{L}{g}} \quad (32)$$

Therefore in equations (25) and (26),  $g/L$  can be replaced by  $(2\pi/T_0)^2$ ;  $T_0$  can readily be determined by observation.  $V = L/i$  is the length of a simple mathematical pendulum having the same period as the instrument under consideration.

Equation (26) may now be written

$$\frac{d^2 \alpha}{dt^2} + \frac{g}{L} \alpha = F \sin \theta + T_p I = 0 \quad (26a)$$

It contains four constants, and when these are known the characteristics of the instrument are known. Two instruments, however they may differ in mass, size, shape, and even in type, as we shall see later, will give identical records of the same disturbance if these constants are respectively equal for the two instruments.

We have seen that  $JJ$  can very easily be determined through equation (32) by determining the period of vibration.  $V$  can be found by measuring the various quantities which define it in equation (29). Instead of measuring the value of  $L$  it can be found from  $L'$  through the relation  $L = iL'$ , after  $i$  has been found by one of the methods given below.

<sup>1</sup> If we use the displacement of the pointer to measure the rotation we have  $u_v = ia/VL$ .

There is a direct experimental method of determining  $V$  due to Professor Wiechert.<sup>1</sup> Displace the pendulum by applying a small force  $f$  at right angles to it and at a distance  $l'$  from the axis of rotation. Its moment will be  $fl'$ . The equal moment of restitution exerted by the pendulum will be  $Mgi\delta$ , where  $\delta$  is the angular displacement of the pendulum; this appears immediately from the theory of vibrating bodies if we replace  $L$  in equation (32) by its value  $lI/Ml$ .

Equating these two moments we find  $iO = fl'/Mg$ . If the marking point at the same time has been displaced a distance  $a_v$  then

$$V = \frac{a_v}{iO} = \frac{h/LB = a_v/Ui\delta}{iO} \quad (33)$$

$a_v$  is observed,  $L'$  determined through the period of vibration, and  $iO$  calculated by the moment of the applied force, as above.

In applying the force Professor Wiechert uses what is practically the beam of a balance with a vertical pointer; the latter presses against the pendulum with a force due to a weight placed at the end of the beam. If the length of the pointer is half the length of the beam, then a weight  $mg$  placed on the end of the beam will exert a pressure  $mg$  against the pendulum; and we find  $\delta = ml'/Ml$ .

Equation (32) also enables us to determine the value of  $i$ , which can not be measured directly with any degree of accuracy;  $L$  can be determined by measuring the quantities entering its definition (p. 155);  $g$  is supposed known and  $i$  can then be calculated. A special arrangement by which the von Rebeur-Paschwitz pendulum can be swung with its axis of rotation horizontal enables us to determine its  $i$  and  $L$  with ease. When  $i$  is large it must be replaced in the equation (32) by the accurate term  $\sin i$ ; when  $i$  is  $90^\circ$  this becomes unity, and we get for the period

$$T_* = 2\pi\sqrt{\frac{L}{g}}$$

from which  $L$  can be immediately calculated. When the pendulum is hung so that  $i$  is small, the period is given by equation (32), hence

$$i = TS/T_0^* \quad (34)$$

We have seen that if we tilt the support through an angle  $a$ , the pendulum is displaced through an angle  $\delta = \frac{a}{i}$ . It is easy to produce a known tilt on a Milne instrument by means of the leveling screws, and on the Bosch-Omori instrument by means of the horizontal adjusting screw at the top of the supporting column. The value of  $i$  can then be calculated by measuring  $\delta$  directly, or by calculating it through the displacement  $a_t$  of the pointer; for,  $VL = a_t/\delta = \overline{ml}_t$ ; and  $\overline{m}$  and  $l_t$  are very easily measured.

Returning again to equation (26), neglecting the solid friction and supposing no disturbance, the equation becomes

$$\mathcal{D}^2 a + \mathcal{C}^2 a = 0 \quad (35)$$

of which the solution is

$$a = a_0 \sin \mathcal{C}(t - t_0) \quad (36)$$

provided  $2\pi/T_0$  is greater than  $\mathcal{C}$ .  $a_0$  and  $t_0$  are constants to be determined by the initial conditions and  $T$  is given by

$$\left(\frac{2\pi}{T}\right)^2 = \mathcal{C}^2 = \frac{g}{L} \quad (37)$$

<sup>1</sup> Reiter's Geophysik, vol. VI, p. 44S.

also 
$$\left| \frac{a_0}{a_n} \right| = \frac{1}{\sqrt{1 + \frac{K^2 T^2}{4\pi^2}}} \quad (38)$$

$$\therefore n = \frac{1}{\sqrt{1 + \frac{K^2 T^2}{4\pi^2}}} \quad (38a)$$

If  $\frac{K}{2\pi}$  is small, we can deduce

If, as in the majority of pendulums now in use, there is no especial device for damping,  $K$  is a very small quantity and we may, to a close degree of approximation, write  $T = T_0$  and  $2\pi r/T = 2\pi r/T_0$ .

The solution, equation (36), represents a simple harmonic motion with decreasing amplitude given by  $a_0 e^{-Kt}$ ; to determine the successive maximum swings in opposite sides of the central line, we put  $t = 0, T/2, 2T/2, \dots$ , in the expression. The ratio of these successive values of the amplitude is constant and equals  $V^{1/2}$ ; i.e., if  $a_0, a_1, a_2, \dots$ , are the successive maximum displacements we have

$$\frac{a_0}{a_n} = \frac{a_0}{a_n} e^{-Kt} = e^{-Kt} \quad (39)$$

this quantity is called the *damping ratio*. To determine the value of  $tc$ , take the natural logarithms of both sides of equation (40); we get

$$\log_e \frac{a_0}{a_n} = 2.3026 \log_{10} \frac{a_0}{a_n} = A \quad (41)$$

where  $\log$  stands for the logarithm to the base 10.  $A$  is called the logarithmic decrement of the amplitude. From this equation we can calculate  $tc$ , but as it is difficult to get a good determination of the ratio of two successive amplitudes, we can determine  $K$  from the ratio of the zeroth to the  $n$ th. amplitude, as follows: Multiply together the successive ratios of equation (40) and we get

$$\frac{a_0}{a_n} = e^{-2\pi n} \quad (42)$$

take logarithms of both sides of the equation, and we get

$$\frac{1}{n} \log_{10} \frac{a_0}{a_n} = \frac{2.3026}{n} \log_{10} \frac{a_0}{a_n} = \frac{A}{2} \quad (43)$$

This gives us more accurate values of  $\frac{K}{2\pi}$  and  $A$ . The quantity needed to determine  $T_0$  in equation (39) is  $KT/2\pi$ , and this becomes

$$\frac{K}{2\pi} T = \frac{2.8026}{n} \log_{10} \frac{a_0}{a_n} = \frac{0.733}{n} \log_{10} \frac{a_0}{a_n} = \frac{A}{2} \quad (44)$$

In determining  $K$  or  $KT/2\pi$ , one naturally observes  $a_0$  and  $a_n$ ; but the logarithmic decrement,  $A$ , is a recognized constant, and is the quantity usually recorded to indicate the damping of the instrument. It is to be noticed that the logarithmic decrement is not a constant, but is proportional to the damped period.

We also have from equation (38)

$$\left( \frac{KT}{2\pi} \right)^2 = \left( \frac{KT}{2\pi} \right)^2 / \left\{ 1 + \left( \frac{KT}{2\pi} \right)^2 \right\} \quad (44a)$$

and through equations (40) and (41)

$$\left( \frac{KT}{2\pi} \right)^2 = \frac{\log_e^2 \frac{a_0}{a_n}}{1 + \log_e^2 \frac{a_0}{a_n}} = \frac{\log_e^2 \frac{a_0}{a_n}}{1.862 + \log_e^2 \frac{a_0}{a_n}} \quad (44b)$$

The use of this formula is the quickest means of calculating the value of  $*T_0/2 TT_1$  which enters the expression for the magnifying power of the seismograph for harmonic vibrations.

The vibrations of the pendulum under damping lie between two exponential curves,  $e^{-kt}$  and  $-e^{-kt}$  as shown in figure 40.

There are few instruments free of all solid friction; this enters at the pivots and at the marking point. At the pivot it is merely a constant moment tending to stop the motion; but it may have a somewhat different value for motion in opposite direction. At the marking point the effect is different; in figure 41, let  $a$  be the pivot, and  $b$  the marking point of the indicator; let the recording paper be moving to the right with a velocity of  $v''$ ; let the marking point be moving to reduce  $\theta'$  with a velocity  $v'$ ;  $be$  and  $bd$ , as shown in the figure, will indicate the movements of the marking point relative to the paper, as the result of these movements respectively; the resultant relative motion will be  $be$ , and the frictional force which will be directed in the direction opposite to  $be$  may be represented by a constant  $\langle \mathcal{E} \rangle$ . Let  $\alpha$  be the angle which its direction makes with the direction of motion of the paper, and let  $\&$  be the angular displacement of the lever from the same direction (which should be its direction of equilibrium).

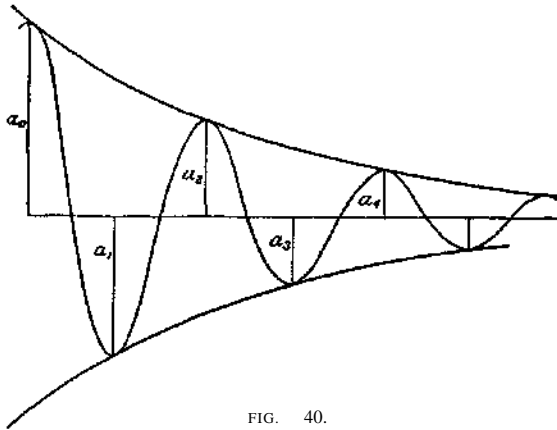

FIG. 40.

We may divide  $\langle \mathcal{E} \rangle$  into two components, one in the direction of the lever, which is resisted by a reaction at the pivot and does not tend to rotate the lever; a second at

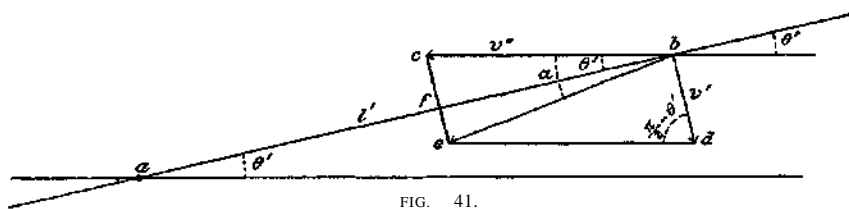

FIG. 41.

right angles to the lever, which exercises a moment to turn it; to determine this moment we must get the component of  $\langle \mathcal{E} \rangle$  in the direction of  $v'$  and multiply it by  $V$ . This effective moment is

$$-\langle bl' \sin(a - \theta') \rangle = -\frac{\langle \mathcal{E} \rangle l' \sin \alpha}{be} = -\frac{\langle \mathcal{E} \rangle l' \sin \alpha}{V u^{ff} + v'' - 2l' V \sin \theta'} \frac{v' - v'' \sin \theta'}{C^{40}}$$

This can be developed in powers of  $v'/v''$  (which we will write  $i_n$ ) or of  $v''/v'$  (or  $v^{\wedge}$ ) whichever is less than unity, and we get

$$\langle j \rangle V (l - v_x'' \sin \theta') (1 - l' V S + v'' \sin \theta' + \dots) \quad (46)$$

or

If the lever is moving very rapidly in comparison with the paper,  $v''$  becomes a small quantity, it may be neglected, and the first expression becomes  $l' V$ , that is, there is a constant moment tending to stop the motion of the pendulum. If the paper is moving very rapidly in comparison with the lever,  $v_n'$  is a small quantity, and the second expression reduces to  $\frac{1}{2} (i_n' - \sin \theta' - v_n' \sin^2 \theta' + \dots)$ ; which, when  $\theta'$  is small,



become  $\delta'(\theta' - \theta)$ , this represents a moment proportional to the velocity of the lever, and a second proportional to the displacement.

In the intermediate case where neither  $v'$  nor  $v''$  is preponderatingly large, the frictional moment is a complex function of their ratio and of the angular displacement. In any large swing the recording point may pass thru its position of equilibrium with a velocity much larger than that of the paper, but as it reaches the limit of its swing its velocity gradually reduces to zero; hence the nature of the moment brought into play varies materially during the swing. As the lever passes its zero position the friction exercises a constant moment; and as it approaches the maximum displacement the friction exercises a damping moment, and a force of restitution.

It sometimes happens, on account of a slight tilting of the pier, that the pendulum's equilibrium position is not exactly in a line with the pivot of the indicator lever, so that

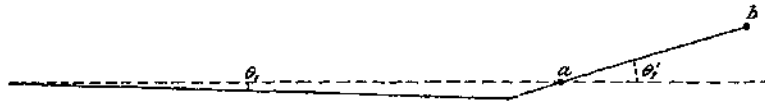

FIG. 42.

the lever stands at an angle with the pendulum. The frictional moment has the same expression as we have already found except that we must replace  $\delta'$  by  $\delta' + \theta'$ , where  $\theta'$  is the angular displacement of the indicator when the pendulum is at rest, and  $\delta'$  the displacement from this position during a disturbance. The limiting cases (as on p. 161) become  $\theta' > \theta'$  and  $\theta' < \theta'$  if  $\theta'$  and  $\theta'$  are not large; that is, in the second case, we must add to the moments already considered another moment which tends to bring the pendulum back to the proper position of equilibrium.

Let us see what is the nature of the frictional moment in a special case; let us suppose we have a simple harmonic swing of the marking point of period,  $P = 15$  sees., and amplitude 4 cm.; let the velocity of the paper be 1.5 cm. per minute, or  $v'' = 0.025$  cm. per second. We have supposed the swing simple harmonic, which it would not be under the action of the friction, but it would be approximately so, and we can get a fair idea of the variation of the frictional moment under this supposition. If  $y$  is the displacement, we shall have

$$y = a \sin \frac{2\pi}{P} t; \quad v' = \frac{dy}{dt} = \frac{2\pi a}{P} \cos \frac{2\pi}{P} t$$

then  $2\pi a/P = 25/15 = 1.67$ , and putting the successive values of the sine in the general equation for the frictional moment (45), we find that the force does not vary much for something over an eighth of the period on each side as the pointer crosses the zero position, and it changes very quickly near the ends of the swings; for movements therefore in which the maximum value of  $v'/v''$  is of the order of  $1.67/0.025 = 67$ , the frictional moment does not vary much in value during a large part of the swing. It would produce a much too complicated expression to introduce the actual value of the frictional moment into the equation of the pendulum; the best we can do is to look upon it as made up of a damping moment, which would enter the general damping term, a moment proportional to the displacement, which would combine with a similar term in the equation, and of a constant moment opposed to the motion, which would be represented, together with pivotal friction, by the constant term of the equation. The importance of reducing all this friction to a minimum is evident, for we can not take accurate account of it. Hence the adoption of very heavy pendulums, which reduce the effect of the frictional forces on their motion. That the friction at the recording point is, in general, very important, is shown by the rapid dying out of the vibrations of a Bosch-Omori

pendulum when the pointer is marking, in comparison to the very slow dying down when the marking point does not touch the smoked paper. The effect of the multiplying levers in increasing the influence of the friction can easily be found. Using the same notation as on pages 151, 155, we have

$$f_1 l_2 = f_2 l_1'; f_2 l_3 = f_3 l_2'; \text{ etc.}$$

where for this particular case, the  $f$ 's represent the reaction between the levers brought about by the friction  $\langle f \rangle$ , of the marking point only, and the inertia of the levers is not considered.

This gives

$$f_1 l_1 = f_1 M_{l_2} = \dots = \phi \frac{l_1}{l_2} \wedge \dots \frac{l_1}{l_n} = \phi \bar{m} l_1 = \phi \bar{m} l_1 \quad (47)$$

that is, the frictional moment is proportional to the multiplying power of the levers.

Assuming that the friction adds a damping moment, a moment proportional to the displacement, and a constant moment, opposing the motion of the pendulum, we have still to determine in our general equation (26) the values of the constants  $K$  and  $p'$ . If in this equation we replace  $a$  by  $a' T L p'/gi$ , it becomes

$$\frac{d^2 a'}{dt^2} + \frac{2\pi}{T_0} \frac{da'}{dt} - \frac{\bar{m} l}{L} \frac{d^2 \xi}{dt^2} + \frac{g}{L} \left( \frac{\bar{m} l}{L} a' + a' \right) = 0 \quad (48)$$

the form is unchanged except that the constant term drops out. Therefore the vibration of a pendulum, affected by constant friction, has the same period and is otherwise the same as that of a pendulum without the friction, except that the vibration no longer takes place about the medial line, but about a line displaced from it by an amount  $L p'/gi$ , and this displacement is first on one side of the medial line and then on the other. We may therefore look upon the force of restitution, not as proportional to  $a$ , the displacement, but to  $a$  less  $L p'/gi$ ; and the pendulum can remain at rest anywhere between the two displaced medial lines. Let us call the distance between the true medial line and its displaced position, the "frictional displacement of the medial line," and denote its value,  $L p'/gi$  or  $p' T^2 r$ , by  $r$ . It must be determined by experiment. We have just seen that the frictional moment exerted on the pendulum is proportional to the multiplying power of the levers, therefore the frictional displacement of the point  $l_x$  is proportional to the same quantity; and the frictional displacement of the marking point is  $\bar{m}^2$  times as great, or proportional to the square of the multiplying power. Suppose the frictional displacement of the marking point at  $l_x$  were 0.01 mm., that at the end of one lever multiplying 10 times would be 1 mm.; and at the end of a second similar lever, 100 mm. We can determine the relation between  $p'$ ,  $r$  and  $\langle f \rangle$ ; the frictional force  $\$$  exerted at the marking point equals a force  $\bar{m} \langle f \rangle$  exerted at the point of contact,  $l_v$  of the pendulum and the first lever, and this exerts a moment  $\langle f \rangle \bar{m} l_v$ , and therefore produces an acceleration of the pendulum equal to  $\langle f \rangle \bar{m} Z_j / [I]$ ; this acceleration is represented by  $PQ$  in equation (25). Hence

$$p' = \left( \frac{2\pi}{T_0} \right)^2 \bar{P} \bar{O} - \frac{\phi \bar{m} l \bar{m} l}{U T} \sim \bar{m} \quad (49)$$

In figure 43, let  $a_0, a_1, a_2$ , etc., be the successive excursions measured from the medial line; let  $r$  be the displacement of the medial line; then if there is no damping and the pendulum starts from a displacement  $a_0$ , that is  $a_0 - r$  from the displaced line, it will swing an equal distance to the other side of this line, or  $a_0 - r = a_1 + r$ ;  $\therefore a_1 = a_0 - 2r$ ; as it starts back from  $a_1$  the medial line is suddenly displaced to (2), and  $a_1 - r = a_2 + r$ ;

$\therefore a_2 = a_1 - 2r$ ; and we see that each successive excursion of the pendulum is diminished by  $2r$ . When at last the friction stops the motion between the lines (1) and (2), the point

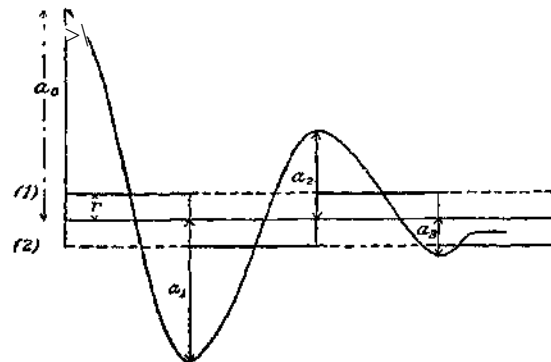

FIG. 43-

will cease to vibrate, the friction being just enough to hold it in the position where it stops. But when the vibration becomes very small, the friction no longer exerts a constant force, but a damping force and a force of restitution, and therefore the marking point would continue to approach the true medial line, being kept from it only by the constant friction of the pivots.

When there is damping, the successive excursions about the displaced lines are not equal, but they gradually

diminish in the ratio  $e^{-KT/a}$ , which we have called  $e$ ; we have therefore

$$\frac{a_0 - r}{a_1 + r} = \frac{a_1 - r}{a_2 + r} = \dots = e \quad (49)$$

and it is from this series of equations that we must determine  $K$  and  $p'$ . As the position of the medial line may be unknown, we can not measure the  $a$ 's, so we must proceed as follows: adding numerators and denominators of the equal fractions we get

$$\frac{a_1 + a_2 - 2r}{a_2 + a_3 + 2r} = e \quad \text{or} \quad \frac{A_1 - 2r}{A_2 + 2r} = \frac{A_2 - 2r}{A_3 + 2r} = \dots = e \quad (50)$$

where  $A_x = a_x + a_v$ ,  $A_0 = a_0 - a_3$ , etc., the  $A$ 's are the ranges of the vibrations, that is, the distances from a maximum excursion on one side to the next on the other. Subtracting the numerators and denominators, the second from the first, the third from the second, etc., we find

$$\frac{A_1 - A_2}{A_2 - A_3} = \frac{A_2 - A_3}{A_3 - A_4} = \dots = e \quad (51)$$

Solving the first equation (50) for  $2r$  and introducing the value of  $e$  from the first equation (51), we get

$$2r = \frac{A_2 - A_1 A_2}{A_1 - A_2} \quad (52)$$

Equations (51) and (52) enable us to determine the values of  $e$  and  $r$  from the measure of three successive ranges; these equations are suitable when the ranges diminish rapidly in value; but when they diminish very slowly, these equations will not yield accurate values, and we must deduce others containing ranges which are sufficiently far apart to have materially different values. We proceed as follows: add the numerators and the denominators of equations (51) and we get

$$\frac{A_1 - A_m}{A_2 - A_{m+1}} = \frac{A_2 - A_{m+1}}{A_3 - A_{m+2}} = \dots = e \quad (53)$$

multiplying  $n$  of these fractions together, we get

$$\frac{A_1 - A_m}{A_{n+1} - A_{n+m}} = e^n$$

$m$  and  $n$  may be any numbers we please; let us take  $m = n + 1$ , and the formula becomes

$$\frac{A_1 - A_{n+1}}{A_{n+1} - A_{2n+1}} = e^{n+1} = gwr/s \quad (54)$$

From this we deduce as before

$$\frac{MM}{2\pi n} \dots \frac{A-i}{A+i-A_{n+i}} \dots \quad (55) \quad , \quad \frac{A}{TMT} \frac{\wedge}{\dots} = \frac{\wedge}{A_{n+1}-A_{2n+1}} \quad (56)$$

Solving equation (50) for 2 r, we get

$$2r = \frac{A - \epsilon A}{1 + e} - \frac{\epsilon^2 A}{1 + e} \dots \epsilon^n A$$

$$= \frac{A - \epsilon A}{1 + e} = \frac{eA - \epsilon^2 A}{e(1 + e)} \dots \text{etc}$$

adding numerators and denominators

$$2r = \frac{A - \epsilon^{n+1} A}{1 - \epsilon^{n+1}} = \frac{A - \epsilon^{n+1} A}{1 - \epsilon^{n+1}}$$

replacing value of  $\epsilon^n$  from equation (54) we get

$$2r = \frac{\epsilon^n A}{e + 1} \frac{A^2 - A_1 A_{2n+1}}{(A - A_1) - (A_{n+1} - A_{2n+1})} \quad (57)$$

Equations (55), (56) and (57) are perfectly general; and n may be given any integral value greater than 0. The factor (e — 1) in equation (57) reduces the accuracy in the determination of r when e is nearly equal to 1; but e can be determined with considerable accuracy from equation (54) if we have a good record of free vibrations without outside disturbance, r being thus determined, we can find p' and <math>\xi</math> from equation (48a). Thus the damping and frictional constants can be determined from the measure of 3 ranges.

Returning now to equation (35), let us consider the case where the friction is so great that the movement is no longer periodic so that we can not determine K and p' by the above methods. We shall then have  $K > 2\pi/T_0$ , and the solution of the equation (35) under this condition is

$$a = A_1 e^{-m_1 t} + A_2 e^{-m_2 t} \quad (58)$$

where

$$m_1 = K \pm \sqrt{K^2 - n^2}, \quad m_2 = K - \sqrt{K^2 - n^2} \quad (59)$$

and n is written for  $2\pi/T_0$ .  $A_1$  and  $A_2$  are arbitrary constants whose values are to be determined to correspond to the special conditions imposed. Neglecting solid friction for the present, we can determine the value of K by displacing the pendulum an amount  $a_0$  and then setting it free; that is, at time  $t_0$  we have  $a = a_0$  and  $da/dt = 0$ . If we determine  $A_1$  and  $A_2$  to satisfy these conditions, equation (58) becomes

$$a = \frac{5^0}{m_1 - m_2} (m_1 e^{-m_2 t} - m_2 e^{-m_1 t}) \quad 0 \quad )$$

This represents the difference of two exponential curves, and since  $m_1$  is greater than  $m_2$ , the second term in the parenthesis is always smaller than the first and a is always positive; and therefore the pendulum remains on the positive side of the position of equilibrium, gradually approaching it, but only reaching it when t is  $\infty$ .

To determine K we must first determine n or  $2\pi/T_0$ . To do this, reduce the value of K sufficiently to allow a satisfactory perùxlic motion, and determine the period. Increase the value of K until the motion is aperiodic. Now displace the pendulum an amount  $a_0$  and release it exactly at the beat of a seconds pendulum; determine the deflection from its position of equilibrium at, say, every 5 or 10 beats of the pendulum. On substituting the values of  $a_0$ , n, and t in equation (60) we can determine \* by trial, each observation giving a value of K; the average can then be taken. It would be very difficult to deter-

mine  $K$  using the ordinary method of recording; a much better way would be to attach a small mirror to the pendulum and read the deflections with a telescope and scale in the ordinary method used for delicate galvanometers. If electro-magnetic damping is used, it is easy to vary the damping, but with mechanical methods it is much more difficult.

In the particular case when  $K = 2\pi/T_0$  the solution of equation (35) becomes

$$a = e^{-\kappa t} (A_1 + A_2 e^{\kappa t}) \quad (61)$$

If the pendulum were displaced a distance  $a_0$  and released at time  $t = 0$ , the arbitrary constants  $A_1$  and  $A_2$  take such values that the equation becomes

$$a = a_0 e^{-\kappa t} (1 + \kappa t) \quad (62)$$

and the pendulum approaches its position of equilibrium rapidly at first but only reaches it after an infinite time. If we have control over the damping factor, we can attain this condition by starting with a damped periodic vibration and then increasing the value of  $K$  until the pendulum no longer crosses its equilibrium position, when displaced and released; the value of  $K$  would then be  $2\pi/T_0$ .

A second method to determine  $K$  is to start the pendulum into sudden motion by a smart blow delivered at the center of oscillation and then determine the time for it to attain its greatest displacement. Equation (58) becomes under these conditions

$$a = \frac{v_0}{m_1 - m_2} (e^{-m_1 t} - e^{-m_2 t}) \quad (63)$$

where  $v_0$  is the initial velocity. If we put  $da/dt$  equal to zero, we find that the time of greatest displacement,  $t_v$  is given by

$$(m_1 - m_2) t_v = \log \frac{2m_2}{m_1 - m_2} = 0.4343 \log_{10} \frac{m_1}{m_2} \quad (64)$$

Under similar conditions, equation (61) becomes

$$a = v_0 t e^{-\kappa t} \quad (65)$$

and the time of greatest displacement is given by

$$h = \frac{l}{\kappa} \quad (66)$$

The effect of solid friction is merely to shift the position of equilibrium; this, however, is only strictly true provided  $p'$  is truly constant; but we have seen that this is not the case when the movement of the pendulum is slow in comparison with that of the drum, as it would be during a large part of the motion in the case under consideration. Prince Galitzin is the only person so far who has used such excessive damping, and he has used optical registration so that the friction of the marking point is absent. If mechanical registration were to be used with a so strongly damped instrument, a careful experimental study should be made of its effect, as we can not say that we know how to allow for it at present.

#### INTERPRETATION OF THE RECORD.

We have seen how to find the values of the constants which enter the equation of the horizontal pendulum, so that we can apply the equation to a given record and find the corresponding movement of the support. To do this we must integrate the equation;

that is, we must substitute for  $a$ ,  $da/dt$ , and  $d^2a/dt^2$ , their values as given by the record, and we can then calculate  $d^2a/dt^2$ . If, as is generally the case, the record is not a simple regular curve, we must determine the values of  $a$  and those of its derivatives for points of the curve at very small intervals and then integrate the resulting values of  $d^2a/dt^2$ , graphically or otherwise. This process is very long. If, on the other hand, the record is a simple harmonic curve, and it frequently approximates this for short times, we can integrate the equation directly. Equation (26) becomes, after substituting the values of the coefficients,

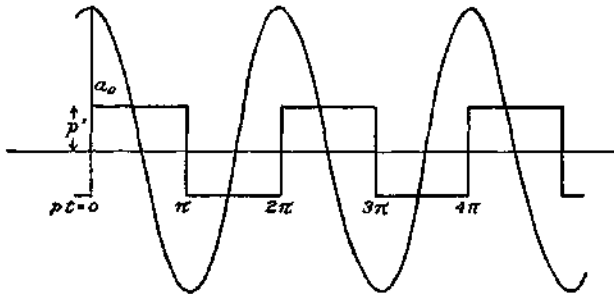

FIG. 44.

$$\frac{d^2a}{dt^2} + 2\kappa \frac{da}{dt} + n^2a - V \frac{d^2\xi}{dt^2} + Vg\omega_v \mp p' = 0 \quad (67)$$

where we have put  $n^2$  for  $g/L$ , or  $(2^r r/T_0)^2$ , by equation (32).

Let us suppose first that there is no rotation, and the term  $Vg\omega_v$  disappears. Choosing the origin of time when the pendulum has its greatest elongation in the positive direction, we can write

$$a = a_0 \cos(2ir/F)t = a_0 \cos pt \quad (68)$$

$$da/dt = -pa_0 \sin pt; \quad da^2/dt^2 = -p^2 a_0 \cos pt \quad (69)$$

$p'$  is a discontinuous function, having a constant numerical value, but suddenly changing sign with the velocity which it always opposes. We can represent it by the series

$$p' = \frac{4}{\pi} \sum_{n=1}^{\infty} \frac{1}{n} \sin np t + \frac{1}{3} \sin 3pt + \frac{1}{5} \sin 5pt + \dots \quad (70)$$

where  $n^2 r$ , or  $(2^r r/T_0)V$ , as in equation (48a), is the positive numerical value of  $p'$ ; this series represents the broken line in figure 44 for all values of  $t$ . Substituting the above values in the equation of the pendulum, it reduces to

$$V \frac{d^2\xi}{dt^2} = A \cos(pt - \chi) - \frac{4n^2 r}{\pi} (\sin pt + \frac{1}{3} \sin 3pt + \dots) \quad (71)$$

where

$$A \cos \chi = \frac{4n^2 r}{\pi} \frac{1}{p^2}; \quad A \sin \chi = -\frac{4n^2 r}{\pi p} \quad A^2 = \frac{16n^4 r^2}{\pi^2} \frac{1}{p^2} \quad (72)$$

Multiplying by  $dt$  and integrating from  $t = 0$  to  $t = t$ , we get

$$V \frac{d\xi}{dt} - V \left( \frac{d\xi}{dt} \right)_0 = \frac{A}{p} \sin(pt - \chi) + \frac{A}{p} \sin \chi + \frac{4n^2 r}{\pi p} \left( \cos pt + \frac{1}{3} \cos 3pt + \dots \right) - \frac{4n^2 r}{\pi p} \left( 1 + \frac{1}{3} + \frac{1}{5} + \dots \right) \quad (73)$$

Integrating again, after replacing the last series by its value,  $T^2/S$ , we get

$$V\xi - V\xi_0 - V \left( \frac{d\xi}{dt} \right)_0 t = -\frac{A}{p^2} \cos(pt - \chi) + \frac{A}{p^2} \cos \chi + \frac{A}{p} \sin \chi \cdot t + \frac{4n^2 r}{\pi p^2} \left( \sin pt + \frac{1}{3} \sin 3pt + \dots \right) - \frac{\pi n^2 r}{2p} t \quad (74)$$

Since this holds for all values of  $t$ , we must have

$$\left. \begin{aligned} V \left( \frac{d^2 h}{dt^2} \right) &= -\frac{A}{p} \sin x + \frac{r n^2 r}{2p} \\ V \xi_0 &= -\frac{A}{p^2} \cos \chi \\ V \xi &= -\frac{A}{p^2} \cos (pt - \chi) + \frac{4 n^2 r}{\pi p^2} \left( \sin pt + \frac{1}{3^3} \sin 3pt \dots \right) \end{aligned} \right\} \quad (75)$$

The series converges so rapidly that we may neglect all but the first term; indeed, if we attempt to draw the curve represented by the series making the amplitude of the first term 25 mm., that of the second term would be a little less than 1 mm. and would have a small effect (see figure 45); that of the third term would only be  $\frac{1}{27}$  mm., and its effect would hardly be perceptible on this scale. When we consider that the friction is by no means constant during a half swing of the pendulum, and that the curve recorded by our instrument is by no means an accurately harmonic curve, we feel entirely justified in accepting the value of  $\xi$  obtained by neglecting all terms of the series except the first, as representing its true value well within the limits of our observations. We then have

$$V \xi = -\frac{A}{p^2} \cos (pt - \chi) + \frac{4 n^2 r}{\pi p^2} \sin pt = B \cos (p^* t - \phi) \quad (76)$$

where

$$B \cos \phi = \frac{A}{p^2} \cos \chi \quad B \sin \phi = \frac{4 n^2 r}{\pi p^2} \sin \chi \quad B^2 = \frac{A^2}{p^4} - \frac{8 n^2 r}{\pi p^4} A \sin \chi + \frac{16 n^4 r^2}{\pi^2 p^4} \quad (77)$$

If, however, we wish to take into account the second term of the series in equation (75), the second term of equation (76) must be increased by  $(4n^2/7rp^2)(\sin 3^2/27)$ , and we observe that it will have no effect on the maximum amplitude if  $\chi$  is 0, or  $\pm 60^\circ$ , or

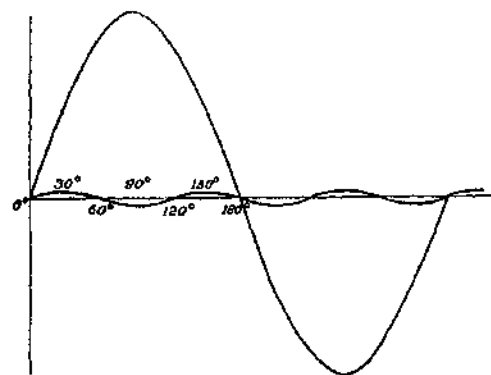

FIG. 45.

$\pm 120^\circ$ , or  $\pm 180^\circ$ ; that it will increase  $B$  by  $4rn^2/277rp^2$  if  $\chi = +30^\circ$ , or  $+150^\circ$ , or  $-90^\circ$ ; that it will decrease it by the same amount if  $\chi = -30^\circ$ , or  $-150^\circ$ , or  $+90^\circ$ . If we suppose the period of the disturbance to be twice that of the pendulum,  $n^2/p^2 = 4$ ; and if  $r = 0.2$  cm., then the change in  $B$  may, at most, amount to  $0.8 \times 4/27 TT$ , or about 2V cm.; and if  $V$  is 10, the alteration in the calculated value of the amplitude of the earth's disturbance may amount to  $\frac{1}{27}$  cm. or  $\frac{1}{27}$  mm. As the actual amplitude is apt to be one or more millimeters to produce a movement large enough to justify us in

regarding  $p^f$  as a constant and thus make these calculations apply, the effect of the second term of the series may be neglected within the limits of errors of observations and theory. These data are fair values for the Bosch-Omori seismograph; for other instruments they would have to be modified.<sup>1</sup>

<sup>1</sup> If we wish to avoid all approximations in our solution, we can do so by replacing the two series of equation (73) by their values

$$\frac{\pi n^2 r}{2p} \frac{d^2 h}{dt^2} = \frac{4 n^2 r}{\pi p} \left[ \cos pt + \frac{1}{3^2} \cos 3pt + \dots \right] \quad \frac{v r f r}{2j \theta} = \frac{4 n^2 r}{v p} \left( 1 + \frac{1}{3^2} + \dots \right)$$

on integrating we find

$$V \xi = -\frac{A}{p^2} \cos (pt - \chi) + \frac{\pi n^2 r t}{2p} - \frac{n^2 r t^2}{2}$$

This equals the values given by equation (75) between  $t=0$  and  $t=P/2$ ; but it does not hold outside these values; and the variation from the harmonic form is not so readily seen.

We find, therefore, that a simple harmonic record corresponds pretty closely to a simple harmonic disturbance magnified in the proportion of

$$\frac{a_0}{B/V} = \frac{a_0 v}{\sqrt{A^2/p^4 + (8n^2r/\pi p^4) A \sin \chi + 16n^4r^2/\pi^2 p^4}} \quad (78)$$

since  $B/V$  is the amplitude of the movement of the support or the earth. In the simple case where  $r=Q$ , or where it is small enough to be neglected, the denominator reduces to  $A/p^2$ , and we have, substituting the value of  $A/p^2$  from equation (72)

$$W = \frac{V}{\sqrt{4P^2(K/2TT)^2 + \{(P/T_{of} - I)^2\}}} = \frac{V}{\sqrt{4(KT_{of}/2ir)\{P/T_{of} + \{(P/T_{of} - I)^2\}}}} \quad (79)$$

or by equation (44b)

$$W = \frac{V}{\sqrt{4 \frac{\log^2 \epsilon}{1.862 + \log^2 \epsilon} \left(\frac{P}{T_0}\right)^2 + \left\{\left(\frac{P}{T_0}\right)^2 + 1\right\}}} \quad (79a)$$

This is the formula given by Doctor Zoeppritz and is perhaps in as simple form for calculation as it could be put. It is a function of the ratio  $P/T_0$ ; the constants of the instrument are taken account of in the quantities,  $T_0$ ,  $e$ , and  $V$ ; the latter we have seen equals  $\bar{n}/L$ . In the particular case where  $P = T_0$ , the magnifying power becomes

$$W = \frac{FTT}{KT_0} = \frac{TV^{\wedge-f-\log/e}, Fyi.862 + \log^2 \epsilon}{2 \log_e e} \quad (80)$$

which grows larger as  $K$  or  $e$  grows smaller; but neither  $K$  nor  $e$  can ever absolutely vanish, and therefore this magnifying power can never become infinite, though it may become very large.

If the solid friction may not be neglected, we must use the full denominator of equation (78) and the magnifying power becomes

$$B/V = \frac{V}{\sqrt{4(KT_{of}/2ir)\{P/T_{of} + \{(P/T_{of} - I)^2\}} + \{(P/T_{of} - I)^2\}}}$$

in which  $(KT_{of}/2ir)$  may be replaced by its value given in equation (44b).

The solid friction adds two terms to the denominator and reduces the magnifying power; these terms depend not only on the value of  $KT_{of}$ ,  $P/T_{of}$  and  $r$ , but also on the recorded amplitude, becoming less important as the amplitude increases. These formulæ, equations (79 a) and (81), are rather complicated, and could not be easily and quickly computed.<sup>1</sup> In reporting amplitudes, it would be much better for each observer to determine the magnifying power of his instrument and to report the actual movement of the ground, instead of the movement of his instrument as is usually done.

We have found (p. 168) that a simple harmonic vibration of the pointer,  $a = a_0 \cos pt$ , is the result of an approximately simple harmonic disturbance of the support,  $I = (B/V) \cos(pt - f)$ . This result is true whatever be the value of  $\epsilon$ , therefore it holds whether the free movement of the pendulum is simple harmonic as on page 158, or an exponential curve as on pages 159 and 165. We can reverse the result and say a simple harmonic movement of the support will produce an approximately simple harmonic movement of the pointer.

<sup>1</sup> A table, giving the values of the denominators of (79 b) for various values of  $\epsilon$ , and of  $P/T_0$  has been published by Dr. Karl Zoeppritz in "Seismi.sche Registrierungen in Göttingen im Jahre 1906." Nach. d. K. Geselte. d. Wiaa. Math.-Phys. Kl. Göttingen, 1908.



If the movements of the pendulum are simple harmonic, and due to tilts alone without linear displacements, we merely interchange  $-Vg\cos\theta$  for  $Vd^2Z/dt^2$  in equation (71); we get

$$\omega_y = -\frac{A}{l} \cos(pt - \chi) \mp p' \quad (82)$$

As  $\theta$  does not enter the equation as a derivative, no integration is necessary,  $p'$  changes its value suddenly from  $-p'$  to  $p'$ , or *vice versa*, when  $pt$  is zero or any multiple of  $\pi$ ; therefore  $\omega_y$  consists of parts of a simple harmonic curve separated by sudden discontinuities at these times. But as we can not admit discontinuities in the value of  $\cos\theta$ , we must conclude that when  $p'$  has an appreciable value, a simple harmonic movement of the pointer can not be produced by tilts of the ground.

We are therefore led to reverse the process and determine what movement of the pointer would be produced by a simple harmonic tilt of the ground. We must replace  $Vg\cos\theta$  in equation (67) by  $E\cos(pt - f_0)$  and integrate the equation after omitting  $Vd^2Z/dt^2$ . (The same solution would apply to the case of simple harmonic linear displacements if we omitted  $Vg\cos\theta$ , and replaced  $Vd^2Z/dt^2$  by  $E\cos(pt - f_0)$ ; that is, if we made  $f = -(E/Vp^2)\cos(pt - f_0)$ .) The solution of the equation would then be very simple if we could neglect  $p'$ , but when we consider this term it becomes rather complicated; but it can be found. From the nature of the disturbing force, and on account of the damping and friction, it is evident that after a short time the movement of the pendulum must become periodic and have the same period as the force. We can therefore write the solution in the general form

$$a = a_1 \cos pt - f a_2 \cos(2pt - f/2) - f \dots \text{etc.} = \sum a_m \cos(mpt - f/m) \quad (83)$$

where  $m$  represents all positive integers. It is also evident that the arms of the broken curve in figure 46 (which represents the movements of the pointer; the continuous curve represents the disturbance) from  $a_0$  to  $a_x$

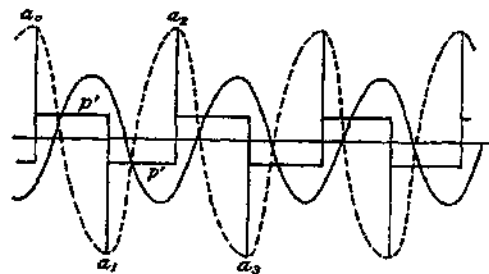

Fig. 46.

and from  $a_x$  to  $a_v$  must be perfectly similar, as the forces when the pendulum is moving in one direction are exactly the negative of those when it is moving in the opposite direction. Therefore the time the pendulum takes to swing from  $a_0$  to  $a_t$  will be exactly half its period, and if we take the time as zero when the pendulum is at  $a_0$ , its maximum displacement, we can develop  $p'$  as a series of sines of the form of equation (70). Sub-

stituting these values in equation (67), after omitting  $Vd^2Z/dt^2$ , and requiring the equation to be identically satisfied, we have, with the equation  $da/dt=0$  when  $\xi=0$ , a sufficient number of conditions to determine the values of the amplitudes  $a_1, a_2, \dots$ , and the phases  $f_1, f_2, \dots$  of equation (83), and thus completely to determine this solution. The work is rather long and it will be sufficient to give the result. We find for the solution

$$\left. \begin{aligned} a_1 &= \sqrt{Q^2 + S^2/p} \\ a_m &= \frac{Q \cos pt + \sin pt - \sqrt{\frac{4n^2 r^2 \cos^2 pt + (m^2 p^2 - n^2)^2}{(m^2 p^2 - n^2)^2 + (2Kmp)^2}}}{p} \end{aligned} \right\} \quad (84)$$

where  $m$  has all odd positive integral values greater than 1.  $a_m = 0$ , when  $m$  is even.

$$S = \sum \frac{4n^2 r^2 \cos^2 pt + (m^2 p^2 - n^2)^2}{\pi m (m^2 p^2 - n^2)^2 + (2Kmp)^2} - w^2$$

with the same values of  $m$ .

$Q$  is found from the quadratic equation

$$Q^2 \frac{N^2 + (2\kappa p)^2}{p^2} + 2Q \frac{8\kappa n^2 r}{\pi} + \delta^2 \frac{N^2 + (2\kappa p)^2}{p^2} + \left(\frac{4n^2 r}{\pi}\right)^2 - \frac{8NSn^2 r}{\pi p} - E^2 = 0$$

where  $N'$  is written for  $n^2 - p^2$ . The other letters have the same meanings as heretofore.

$$\sin iZ_m = \frac{m^2 p^2 - n^2}{\sqrt{(m^2 p^2 - n^2)^2 + (2\kappa m p)^2}} \cos iZ_m = \frac{2\kappa m p}{\sqrt{(m^2 p^2 - n^2)^2 + (2\kappa m p)^2}}$$

The presence of both sine and cosine terms in (84) shows that the movement of the pointer is not symmetrical about a vertical line. The solution is too complicated to be of any general use and is another example of the disadvantage of solid friction in our seismographs.

If the disturbance is small, it may not be strong enough to overcome the solid friction; referring again to equation (67), we see that no record will be made in the case of linear displacements unless

$$d^2/dt^2 > p'/V, \text{ or } > n^2 r/V, \text{ or } > 4\kappa^2 r/VT_1^2, \text{ or } > f > ml_1/Ml;$$

if

$$f = X \cos pt$$

we must have the maximum acceleration,  $p^2 X > n^2 r/V$ ; that is,  $X > (P/T_n)^2 r/V$ , or  $> (P/2-7r)^2 f > ml_1/Ml$ . If the disturbance is a small tilt,  $\alpha_y$  must be greater than  $p'/Vg$ ; if  $a_y = X_i \cos qt_i$ , in order that a record be made we must have  $Q_i > \pm ir^* r/VgT_i^2$ , or  $> f > ml_j Ml g$ . In studying the action of solid friction it has been supposed to be due both to friction at the pivots and to friction of the marking point; where the latter exists at all it is apt to be much greater than the former. If we are dealing with small disturbances of periods not very short, the friction at the marking point is no longer a constant, but has the characteristic of viscous damping. So that in determining the smallest disturbance that will produce a record, under these conditions, we must suppose  $p'$  to refer to the pivots only and not to the marking point.

Professor Marvin has shown how  $f$  can be practically reduced, and consequently  $p'$  and  $r$ , can be practically reduced. He attaches a small electric vibrator to the frame carrying the lever, and the successive slight jars produced by it diminish the effective solid friction to a large extent.<sup>1</sup>

The solutions we have found, showing the relations between the disturbance and the record when solid friction is present, refer to the final steady condition and do not apply to the beginning of the disturbance. The character of the record at the beginning of a simple harmonic disturbance can not be shown in a continuous form, as we can not represent  $p'$  as a series unless it is periodic and we know the times when it changes sign. In the beginning of a disturbance these conditions will, in general, not hold. The same remark applies to the case where the disturbance consists of two or more simple harmonic motions of different periods. But if  $p'$  can be neglected, these difficulties disappear and the solution of equation (67) becomes simple. If we suppose the disturbance to be made up of a number of simple harmonic linear displacements and tilts, we must write in the equation:

$$\text{whence } \left. \begin{aligned} F \ddot{x} &= C_1 \cos(p_1 t - x_0) + C_2 \cos(p_2 t - x_2) + \dots \\ \frac{d^2}{dt^2} F \sim f &= \sum_{i=1}^n \frac{1}{P_i} \cos(p_i t - x_i) + \dots \end{aligned} \right\} \quad (85)$$

$$\text{and we must write } Vg < f = D_x \cos\{q_1 t - \phi_1\} + D_2 \cos\{\phi_2 - \phi_1\} + \dots \quad (86)$$

<sup>1</sup>Improvements in Seismographs with Mechanical Registration. Monthly Weather Review, 1906, vol. xxxiv, pp. 212-217.

The solution then becomes

$$a = K \cos(p\lambda - x_1) \cos(p\lambda - x_2) + e^{\lambda c} \cos(p\lambda - x_3) \cos(p\lambda - x_4) + \dots \quad (87)$$

where

$$\left. \begin{aligned} a_1 &= \frac{1}{\sqrt{(n^2 - iV)^2 + (2Kp_1)^2}} = \frac{1}{\sqrt{\{j(A/T_0)^2 - 1\}^2 + 4(\kappa T_0/2\pi)^2 (P_1/T_0)^2}} = \frac{1}{\Delta} \\ \sin(\psi_1 - \psi_1) &= \frac{2\kappa p_1}{\sqrt{(n^2 - p_1^2)^2 + (2\kappa p_1)^2}} = \frac{2(\kappa T_0/2\pi)(P_1/T_0)}{\Delta} \\ \cos(\psi_1' - \psi_1) &= \frac{n^2 - p_1^2}{\sqrt{(n^2 - p_1^2)^2 + (2\kappa p_1)^2}} = \frac{(P_1/T_0)^2 - 1}{\Delta} \\ b_1 &= \frac{1}{\sqrt{(n^2 - q_1^2)^2 + (2\kappa q_1)^2}} = \frac{1}{\sqrt{\{(Q_1/T_0)^2 - 1\}^2 + 4(\kappa T_0/2\pi)^2 (Q_1/T_0)^2}} = \frac{1}{\Delta'} \\ \sin(\psi_1' - \psi_1) &= \frac{2(\kappa T_0/2\pi)(Q_1/T_0)}{\Delta'}; \quad \cos(\psi_1' - \psi_1) = \frac{(Q_1/T_0)^2 - 1}{\Delta'} \end{aligned} \right\} \quad (88)$$

with similar forms for the other subscripts; the values of A and A' are evident. And

$$\left. \begin{aligned} K &= A_1 e^{-Kt} \sin(2\pi T/T)(t-t_0); \quad \text{when } K < 2\pi T/T_0 \\ &= e^{-Kt} (A + A\mathcal{E}); \quad \text{when } K = 2\pi T/T_0 \\ &= A_1 e^{m_1 t} + J_2 e^{-m_2 t}; \quad \text{when } K > 2\pi T/T_0 \end{aligned} \right\} \quad (89)$$

where  $J_1$ ,  $A_2$ , and  $t_0$  are arbitrary constants to be determined to satisfy the initial conditions; the value of  $2\pi T/T$  is given by equation (37) and the values of  $m_1$  and  $m_2$  by equation (59).

We see therefore that the movements of the pointer will consist of a number of simple harmonic motions of the same periods as the disturbance, but with a difference of phase, and of the proper movement of the pendulum, which is well marked at the beginning of the movement, but dies down more rapidly as  $K$  is larger. Altho we have seen that we can not get a general solution when there is solid friction, as we have when this is absent, nevertheless it seems pretty certain that the effect of solid friction would be to shorten the interval of irregular movement of the pendulum before the regular harmonic movements are established.

#### MAGNIFICATION OF HARMONIC DISTURBANCES.

The magnification of each simple linear harmonic movement is given by the ratio of the amplitude of the pointer to that of the disturbance corresponding to that movement; that is,  $a + C\sqrt{V}$  this becomes

$$W = \frac{a_1 V}{C_1} = \frac{p_1^2 V}{\sqrt{(n^2 - p_1^2)^2 + (2\kappa p_1)^2}} = \frac{V}{\sqrt{\{(P_1/T_0)^2 - 1\}^2 + 4(\kappa T_0/2\pi)^2 (P_1/T_0)^2}} \quad (90)$$

which is the expression we have already found in equation (79).

To determine the magnifying power for tilts, we must compare the maximum angular displacement of the marking lever with the maximum angular tilt of the support. If  $l$  is the length of the long arm of the marking lever, its maximum angular displacement for a particular movement will be  $h/l$  and the maximum tilt will be  $D\sqrt{V}g$ ; the ratio becomes

$$U = \frac{b_1 V g}{h} = \frac{(Q_1/T_0)^2}{\sqrt{\{(Q_1/T_0)^2 - 1\}^2 + 4(\kappa T_0/2\pi)^2 (Q_1/T_0)^2}} \quad (91)$$

here  $Q_1$  is the period of that particular movement of the support.

A glance at equations (88), (90), and (91) shows that in the record the magnification and change of phase of the various harmonic movements of the disturbance are different for different periods, and therefore the curve of the record will not be the same as the

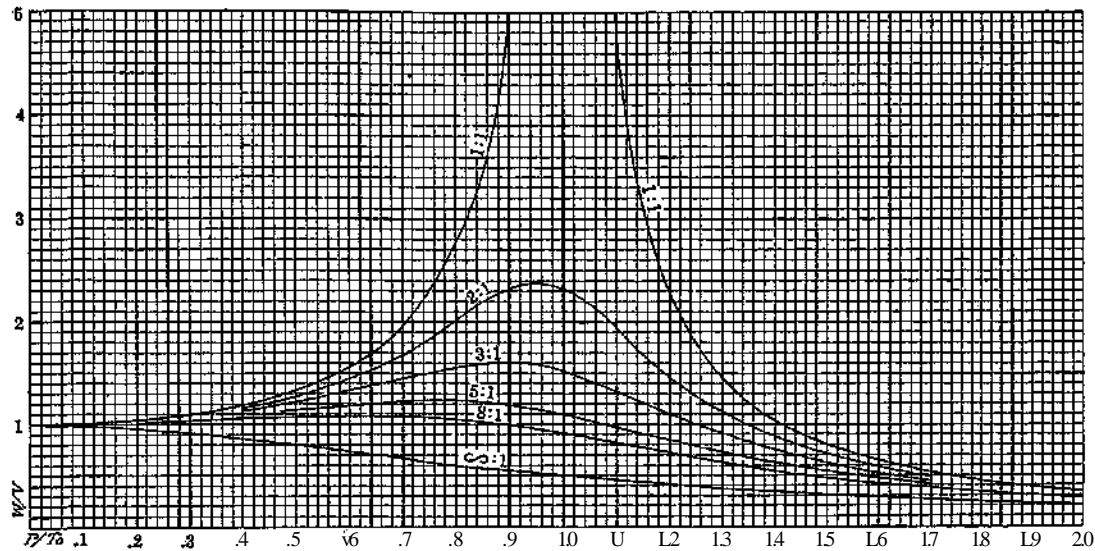

FIG. 47.—Magnifying power of linear displacements.

curve of the disturbance, if the latter consists of movements of more than one period; and it is not possible by increasing  $K$  to equalize the magnification of the movements for different periods and the phase differences, and make the two curves alike; but it might be possible to pick out the different harmonic movements in the record and then

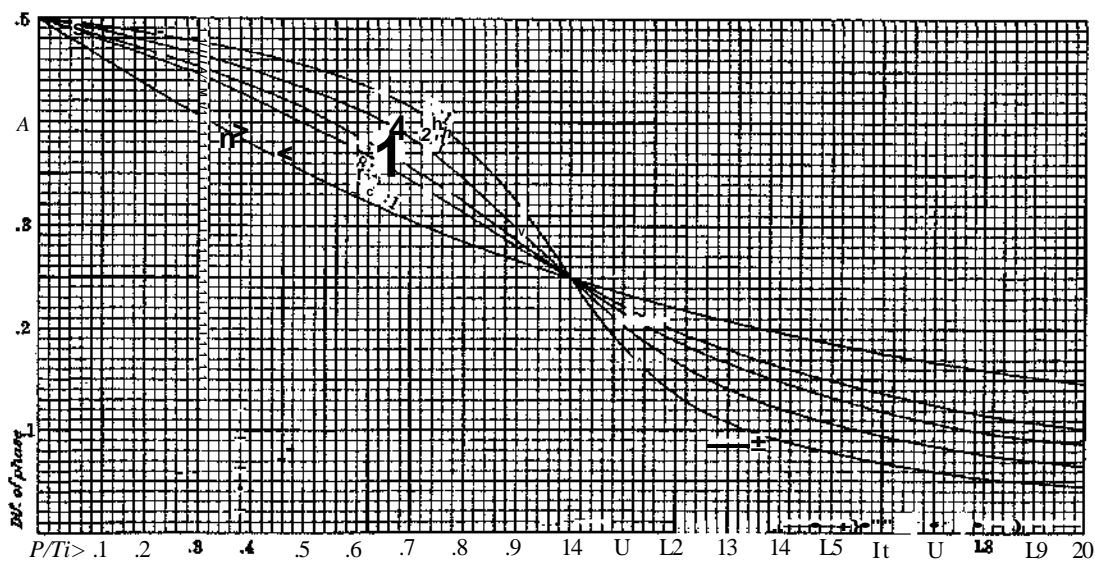

FIG. 48.—Differences of phase for linear displacements.

to calculate the harmonic movements of the disturbance; we could not, however, determine whether these movements were linear displacements or tilts. To make clear the influence of damping, I have, following Professor Wiechert, drawn the diagrams, figures 47 and 48. Figure 47 shows the relative magnifying powers for linear displacements for various values of the damping ratio and for different ratios of the periods of the

disturbance and the free period of the pendulum; the curves are calculated from equation (90). Figure 48 shows the phase differences for the same variables calculated from equation (88).<sup>1</sup> We notice that for values of  $e$  not too large, the magnifying power increases with the ratio of the periods to a maximum and then diminishes indefinitely. The position of the maximum, found by equating to zero the derivative of (90) with respect to  $P/T_0$ , occurs when

$$\left(\frac{P}{T_0}\right)^2 = 1 - 2 \left(\frac{K T_0}{2\pi}\right)^2 Y \quad (92)$$

and its value is

$$W(max) = \frac{V}{\sqrt{1 - (K T_0 / 2\pi)^4}} \quad (93)$$

For small values of  $e$  the magnifying power varies enormously for different periods, becoming very large for periods approaching the free period. Instruments with small damping emphasize certain periods unduly. As we increase  $e$ ,  $W$  becomes more uniform and when  $e$  is about 8:1,  $W$  varies by less than one-tenth of its value for all periods up to the free period, and is very nearly equal to  $V$ . This amount of damping would be excellent, but it would not make the curves of disturbance and record alike, for altho the magnification of the different periods would be practically the same, figure 48 shows that the phase differences would not. Nevertheless this offers great advantages; in the case of nearly simple harmonic movements, which probably occur not infrequently, our record would show the magnifying power without long calculations, whatever be the period, up to the free period; and the record would show directly the relative displacements in different parts of the disturbance, without unduly magnifying certain parts. With this value of the damping ratio the proper movements of the pendulum would be damped out in one or two vibrations. The longer the proper period of the pendulum, the greater the range of periods over which the magnifying power remains nearly constant. This is the principal advantage of long proper periods when recording harmonic disturbances.

For increasing values of  $e$  the position of the maximum moves to the left and becomes zero when  $1 - 2(c^2/27r)^2 = 0$ , which corresponds to  $e = 23:1$ . For values of  $e$  greater than this there is no maximum; the magnification is greatest for infinitely small values of  $P/T_0$  and diminishes for all greater values; when  $e$  becomes  $\infty:1$ ;  $2IT/KT_0$  equals unity, and the instrument is deadbeat;  $W$  is considerably diminished and varies greatly in value.

The magnifying power for tilts is shown in figure 49; it is equal to the variable part of that for displacements multiplied by  $f/i)(Q/T_0)^2$ . Its value is zero when  $Q/T_0$  is indefinitely small; it increases with this factor and reaches a maximum when

$$\frac{dU}{dQ} = \frac{1}{Q - id \sqrt{K T_0 / 2\pi}} \quad (92a)$$

when its value is

$$U(max) = \frac{\bar{n}}{i} \frac{(Q/T_0)^2}{\sqrt{(Q/T_0)^4 - 1}} \quad (93a)$$

it then diminishes to  $\bar{n}/i$  when  $Q/T_0$  is indefinitely large. The position of the maximum is at  $Q/T_0 = 1$  when  $e = 1$  (*i.e.*,  $K = 0$ ); it moves to the right as  $e$  increases, reaching infinity when  $1 - 2(K T_0 / 2\pi)^2 = 0$ ; or  $e = 23.1$ . For greater values of  $e$  there is no maximum. There is no value of  $e$  which produces a fairly even degree of magnification for even a

<sup>1</sup> For  $e = 1:1$ , the difference of phase is 0.5 for values of  $P/T_0$  less than 1; and is 0 for values of  $P/T_0$  greater than 1.



We can use various values of  $n_x$ , but the best is when  $n_x^2 k (m^{2x} - 1)/(m^2 - 1) = 1$ , which gives for the magnifying power

$$V(max) = \frac{M \bar{l} (m^2 - 1)}{2 m l - V k / \omega^2 - 1 - n^2 k} \quad (95)$$

$x$  can not be less than 1, and  $m$  is usually much greater, so that the radical never differs much from unity; it can therefore be neglected, and we see that the maximum value of  $V$  is independent of the number of levers used, if we give  $n_x$  its best values. If we use only one lever,  $n_x^2 = l/k$ . This is not always practicable; for instance, for the Bosch-Omori instrument,  $l/k = 220,000$ ;  $\therefore \sqrt{l/k} = 470$ ; and since  $l = 75$  cm.,  $l_2$  becomes 0.15 cm.

On the other hand, we can determine the best numbers of levers to use by determining the maximum value of  $V$  for variations of  $x$  in equation (94). This gives

$$x = \frac{1}{2 \log m} \log \frac{m^2 - 1 - n_x^2 k}{n_x^2 k} \quad V(max) = \frac{M \bar{l} (m^2 - 1)}{2 m l - V k / \omega^2 - 1 - n^2 k} \quad (96)$$

For the Bosch-Omori instrument,  $n^2 k = l/k$ , about, and with  $m = 10$ ,  $x$  becomes 2.17, and the maximum value of  $V$  is 78. If we omit  $n_x^2 k$  and 1 in comparison with  $m^2$ , the above expressions become

$$x = \frac{1}{2 \log m} \log \frac{m^2}{n_x^2 k} = \frac{1}{2 \log m} \log \frac{l^2}{n_x^2 k} \quad V(max) = \frac{M \bar{l}}{2 l V k} \quad (97)$$

$k$  and  $\bar{l}$  are not independent; replace  $k$  by its value,  $l^2/I$ . The moment of inertia,  $I$ , of each lever is principally that of the long arm, as the short arm counts but little; if we double the length of the lever, we must at least quadruple its mass to keep it strong enough; we may therefore suppose its moment of inertia equal to  $I^2$ ; introducing this into the values of  $x$  and of  $V(max)$  we get

$$x = \frac{1}{2 \log m} \log \frac{J L}{n_x^2 I^2} \quad V(max) = \frac{M l}{2 W J I} \quad (98)$$

and we see that we get a greater multiplying power, if we use short and light levers, rather than a smaller number of longer and correspondingly heavier ones,  $J I$  depends on the density and distribution of material in the levers, and should be made as small as possible.  $M l / V \sim I$  varies proportionally with  $\sqrt{M}$ , but very little with  $l$ , if  $l$  is several times as large as the radius of gyration of the pendulum about its center of gravity; therefore  $V(max)$  can be increased by increasing  $M$ , rather than by increasing  $l$ .

We have not considered the solid friction of the marking point, which, as has been shown on page 171, increases the minimum acceleration which can be registered in the proportion of the multiplying power of the levers, and is in general so great that it exerts a controlling influence over the possible magnifying power of the instrument. The investigation, therefore, does not apply directly to seismographs with mechanical registration, but would apply to instruments of the same form if direct photographic registration, as in the Milne instrument, were used at the end of the last lever.

This suggests a method of optical registration by which very high magnification can be obtained without placing the recording paper far from the instrument. In the usual optical method the light is reflected directly from a mirror carried by the pendulum; but if the mirror is carried on the axle of a magnifying lever, the angle thru which it turns can be increased very greatly (fig. 50). The magnifying power becomes

$$V = \frac{2 d \theta'}{z e} = \frac{2 M l n_x d}{I + n_x^2 I'} \quad (99)$$

where  $d$  is the distance from the mirror to the recording paper. The best value of  $n^\wedge$  is  $l/l'$ , and the corresponding magnification is  $Mld^\wedge/lP$ . As an example, suppose the pendulum consists of a mass of 10 kg. placed at a distance of 20 cm. from the axis of rotation;  $l$  would be  $4 \times 10^6 \text{ cm.}^2\text{gm.}$ ; let  $l'$  be  $4 \times 10^2 \text{ cm.}^2\text{gm.}$ ; a little greater than that of the lever of the Bosch-Omori instrument; then  $l/l' = 10^4$ , and  $^\wedge = 100$ . If  $d = 100 \text{ cm.}$ , the magnifying power becomes 500. If we desire any other magnification, we can

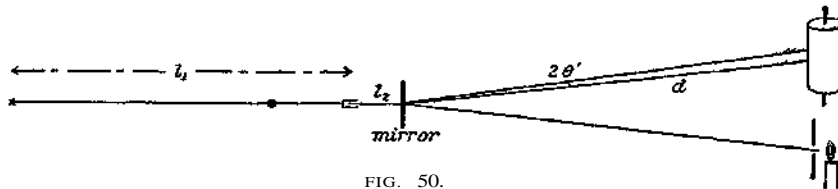

FIG. 50.

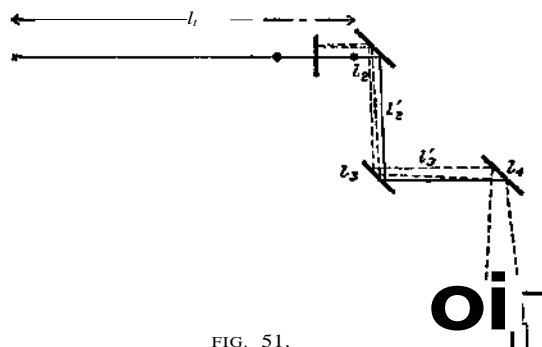
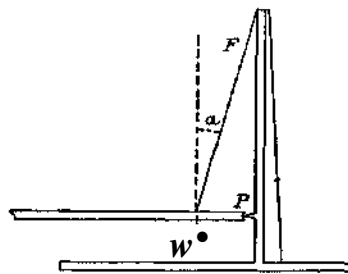

FIG. 51.



Via. 52.

select the proper values of  $M$ ,  $l$ ,  $n_x$  and  $d$  to give it. If a very high value of  $V$  is desired, the arrangement shown in figure 51 can be used. The light is reflected twice from each mirror and at each reflection is deflected thru twice the angle of rotation of the mirror. The magnification becomes

$$V = \frac{Mid4M(1+m+m^2+\dots+m^{x-1})}{I+nl'l(1+m^2+\dots+m^{2x-1})} \sim \frac{Mid4n_l(m+1)(m^x-1)}{(m^2-1)+n^2P(m^{2x}-1)} \quad (100)$$

$d$  is the distance from the last mirror, following the course of the light, to the drum. We have neglected the angle thru which the light is turned by the mirror on the pendulum, for with any fairly large value of  $n_\pm$  it is very small as compared with the total deflection of the light. The best value of  $n_x$  is given by

$$n_1^{2j}/(i^{2j}-1) = (w-1), \text{ or } w \ll (J/l')(i^{2j}-1)/(m^{2x}-1)$$

and

$$V(max) = \frac{2Mid}{Vl^7} \sqrt{\frac{r-1}{m-1} \frac{a}{m^x+1}} \quad (101)$$

The radical is largest when  $x$  is large, but it does not vary much; when  $x = 1$ , it equals 1; when  $x = 2$ , it equals  $\sqrt{(m-1)^2/(m^2+1)}$ , which equals 1.095 if  $m = 10$ ; and when  $x \rightarrow \infty$  and  $m = 10$  it equals 1.111; so that very little is gained by increasing the number of levers, except to get a proper value of  $n_x$  more easily. If  $M = 10,000 \text{ gm.}$ ,  $l = 20 \text{ cm.}$ ,  $d = 100 \text{ cm.}$ ,  $l = 4 \times 10^8$ ,  $l' = 4 \times 10^2$ ,  $x = 1$ ; then  $n_l = 100$ ; and  $V(max) = 2MM/4 \times 10^4 = 1000$ . If we make  $x = 2$ , and  $m = 10$ ; then  $n_x = 10$  and  $V(max) = 1090$ .

If the value of  $n_x$  were fixed, we should find for the best number of levers to use, and the corresponding maximum magnification

$$x = \frac{\log m \left( 1 + \sqrt{1 + \frac{I'}{n_l^2}} \right)}{\log m \left( 1 + \sqrt{1 + \frac{I'}{n_l^2}} \right)} \quad m_1 l' + \sqrt{I l' (m^x - 1)}$$



Taking  $n_t = 50$  and the rest of the data as before, we get  $x = 1.32$ , and  $V(max) = 1000$ , the same value as before; but if we make  $x = 1$ , the nearest practical value, we find  $V(max) = 800$ , which is not very much less. By using steel ribbon for connectors at the axes, and between the pendulum and the levers, or by using one of the devices suggested by Dr. C. Mainka,<sup>1</sup> we could easily get rid of solid friction, and realize the theoretical values above.

#### SUSPENSIONS OF HORIZONTAL PENDULUMS.

There are 4 forms of suspension for horizontal pendulums: (1) The Gray suspension (figure 52); a horizontal beam carrying a weight presses against a point, and is supported by a tie thru its center of gravity. Let  $F$  be the tension of the tie,  $P$  the pressure at the pivot, supposed horizontal, and  $W$  the weight; for equilibrium, these 3 forces must pass thru the same point and we must have

$$F \cos \alpha = W, \text{ or } F = W / \cos \alpha \quad F \sin \alpha = P = W \tan \alpha \quad (103)$$

The friction at  $P$  depends upon the pressure there; and we see it is less as  $\alpha$  is smaller. This can be brought about either by putting the weight closer to the pivot or by length-

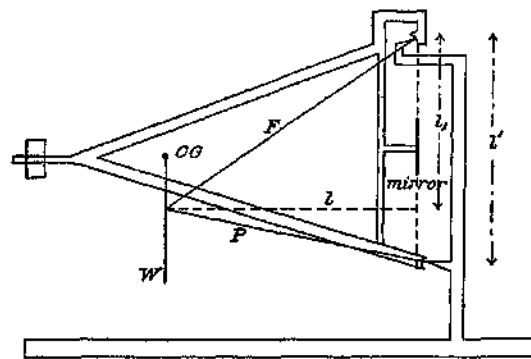

FIG. 53.

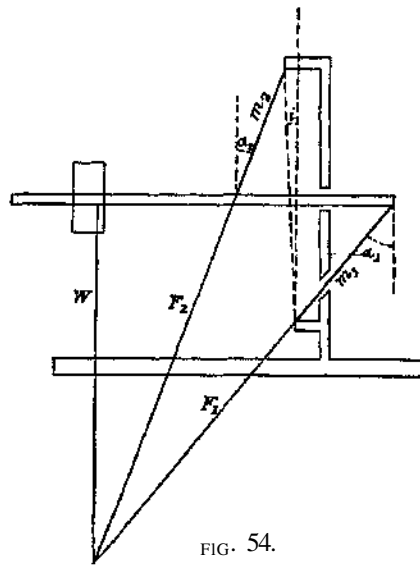

FIG. 54.

ening the distance between the two points of support. By the first method we shorten the distance of the CG from the axis of rotation, and we change the values of the constants in the general equation; by the second method, these constants are not affected.

(2) The Ewing suspension: this differs from the preceding only in replacing the pivot by a thin steel ribbon, thus doing away with the friction at this point. The horizontal beam is extended beyond the axis of rotation and is fastened to the axis by a steel ribbon. Professor Ewing suggested that a steel pin occupying the position of the axis of rotation, and connected firmly with the support, should pass through a slot in the beam, and thus prevent lateral movements of this part of the beam; but this pin introduces some friction. This use of a steel ribbon has only lately been put into practice (by Professor Wiechert).

(3) The von Rebeur-Paschwitz suspension (figure 53): the points of support are sharp steel points resting in agate cups, the upper one being turned to produce a supporting force. The three forces  $P$ ,  $F$ , and  $W$  must meet in a point, which is vertically below or above the center of gravity.

<sup>1</sup> Kurze Uebersicht tiber die modernen Erdbeben-Instrumente. Die Meehaniker, XV Jahrgang, 1907. Since the above was written Prof. C. F. Marvin has suggested a practically similar method for increasing the magnifying power. "A Universal Seismograph for Horizontal Motion." Monthly Weather Rev., 1907, vol. XXXV, pp. 522-534.

The two points of support and the center of gravity lie in a vertical plane when the instrument is in equilibrium. The direction of the forces  $F$  and  $P$  can be somewhat controlled by the direction of the points and of the cups, but friction will alter the direction of the forces to some extent. Usually a plane surface is used instead of one of the cups, which renders it unnecessary that the distance between the points should be exactly the same as the distance between the centers of the cups. Taking moments about the points of support, we find

$$F = \frac{WV}{l} + T \quad P = \frac{TrV}{l} + p \quad (104)$$

where the meanings of the letters are shown in the figure. These forces become equal when  $\alpha = l/2$ , and they make equal angles with the vertical; they then pass thru the  $CG$ ; they become smaller as  $V$  becomes larger in comparison with  $l$ . When the lower point presses against a vertical plane agate surface, the direction of  $P$  is horizontal,  $Z_x = l'$ , and

$$F = \frac{WVl'^2 + P}{l'} \quad p = \frac{Wl'}{l'} \quad (105)$$

$Ul = l', F = IAIP.$

(4) The Zöllner suspension (figure 54); the beam is supported by two wires  $m_1$  and  $m_2$  fastened to the support, one above and one below the beam. The direction of the forces must pass thru the vertical thru the  $CG$  of the beam; and therefore the angle  $a_t$  must be greater than the angle  $\alpha_s$ ; but the values of these angles can only be found thru an equation of the fourth degree, and can only be expressed by a very complicated expression. The Zöllner suspension has the great advantage of not having any pivots, and therefore, if an optical method of registration is used, there is no solid friction. For very slow movements it would answer very well, but for more rapid movements its motion is too complicated. It can have linear displacements parallel with and at right angles to the beam, as well as a rotation around a nearly vertical axis at right angles to the beam. The linear movement parallel with the beam also caused a vertical movement of the mass. These various movements, themselves the effects either of linear displacements or tilts of the support, could not be separated from each other by a single registration; and it would be impossible to interpret the record. To avoid these complications Prince Galitzin has proposed to have the beam press by a point against an agate plate placed close to the axis of rotation, and he has shown that even when the pressure is very light, the device will prevent the first two movements. Another way would be to fasten the point of the beam where it crosses the axis of rotation by guy-wires. They would prevent it from moving out of this position, but would not interfere with small rotations. Prince Galitzin has suggested this method for other instruments. Either of these devices prevents all relative motion except a simple rotation, without introducing friction, and the theory of the instrument then becomes the same as that already given for the Gray or von Rebeur-Paschwitz forms. All instruments of the Zöllner type in use up to the present time have no device to prevent the complicated motions, and in attempting to interpret the records of the California earthquake as given by instruments of this type, we must assume that only rotations take place.

#### THE VERTICAL PENDULUM.

Let us now consider the movements of an ordinary vertical pendulum whose support is subjected to an earthquake disturbance producing the three displacements,  $\xi$ ,  $\eta$ ,  $\zeta$ , and the three rotations,  $\alpha_x$ ,  $\alpha_y$ ,  $\alpha_z$ .

Let  $O$ , figure 55, be the origin of coördinates and let  $X$ ,  $Y$ , and  $Z$  be the coördinates of the point of support; then if  $l$  is the distance from the point of support to the  $CG$ , the

coördinates of the *CG* will be *X, Y, Z*—*I* In the figure, we have omitted the linear displacements for the sake of clearness, and have represented the *CG*, as not moved by the rotations; this introduces no error as the angular rotations are all given their proper values. As in the case of the horizontal pendulum, let us refer the motion of the pendulum to three axes fixed in the pendulum and moving with it; and which are principal axes of inertia. Axis (3) lies in the line from the point of support to the *CG*.

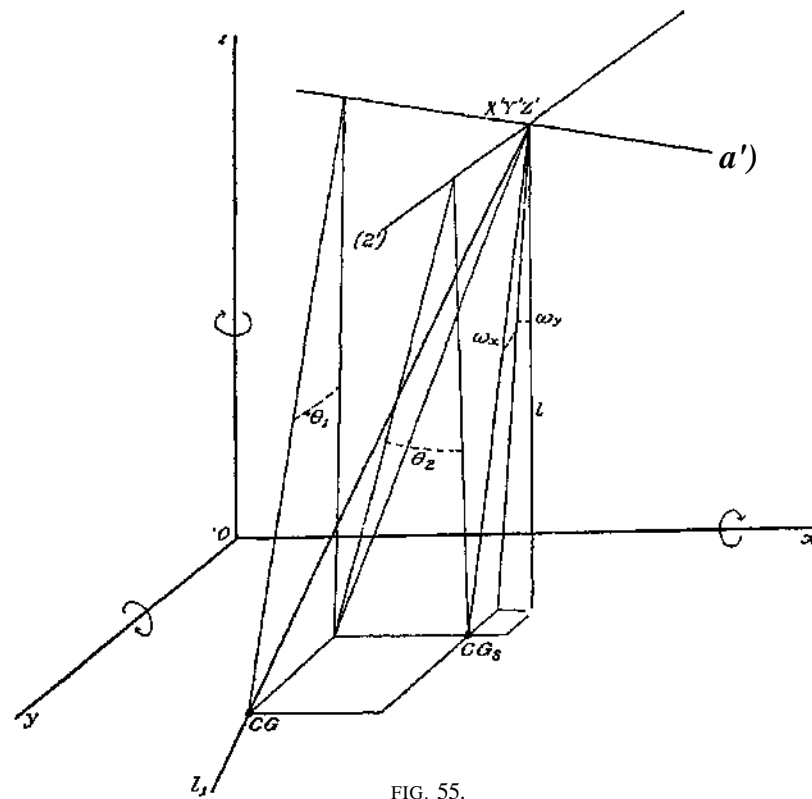

FIG. 55.

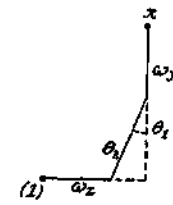

FIG. 56.

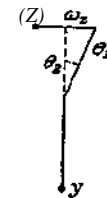

FIG. 57.

Axes (1) and (2) are the rotated positions of lines at right angles to (3) and passing thru the *CG*, which were, before rotation, parallel to the fixed axes of coördinates. Axes parallel with these and passing through the point of support have primes.

We assume that there is no rotation around the axis (3). If the pendulum were supported at a mathematical point, no such rotation could be set up as the direction of the force there passes through the axis; practically the support is a small surface and it might be possible for a small moment to exist around axis (3), but it would be so small that we may safely neglect it.

What is actually measured is the displacement of the *CG* relative to the *CG*,; that is, the angles  $\delta_1$  and  $\delta_2$ ; we must therefore form our equations of motion connecting  $\theta_1$  and #2 with the displacements and rotations. Using the same notation as before, except that  $\delta_x$  and  $\delta_2$  are used for the angular displacements of the *CG* relative to the *CG*, we follow the same method to develop the equations of the pendulum.

The linear accelerations of the *CG* are given by equations (4), and Euler's equations of angular accelerations around the *CG* are

$$I_1 \frac{d^2(\theta_1 + \omega_1)}{dt^2} = A \quad I_2 \frac{d^2(\theta_2 + \omega_2)}{dt^2} = B \quad (106)$$

where  $A$  and  $B$  are the moments of the forces around the axes thru the  $CG$  parallel with (1') and (2'). As before, we have neglected the term containing the product of the angular velocities, as  $a > \delta$ , and therefore its derivatives are practically zero. Let the point of contact of the pendulum and the indicator be at a distance  $l_x$  from the point of support of the former. The indicator may be a vertical lever, in which case  $f_1$  and  $f_2$  are the two components of the reaction; or it may be made up of two horizontal levers with their short arms at right angles to each other, and crossing at the point of contact with the pendulum; in this case  $f_1$  and  $f_2$  are the normal components of the force against each lever, and the frictional components parallel to the levers are neglected as in the case of the horizontal pendulum.

The moments of the forces around the  $CG$  are

$$A = -F_2 l + f_2 (l_2 - l) \quad B = F_1 l - f_1 (l_1 - l) \quad (107)$$

$F_1$  and  $F_2$  are given by two equations similar to equation (10); the cosines of the angles between the axes are obtained from the figures 56 and 57, in the same way as in the case of the horizontal pendulum (p. 152).

$$\left. \begin{aligned} \cos(x, 1) &= \cos(\alpha + \omega_2 t) = \cos(\alpha + \theta_2) \\ \cos(y, 1) &= \sin(\omega_2 t) = \sin(\theta_2) \\ \cos(z, 1) &= -\sin(\alpha + \theta_2) \end{aligned} \right\} \quad (108)$$

$$\left. \begin{aligned} \cos(x, 2) &= -\sin(\omega_2 t) = -\sin(\theta_2) \\ \cos(y, 2) &= \cos(\alpha + \theta_2) \\ \cos(z, 2) &= \sin(\alpha + \theta_2) \end{aligned} \right\} \quad (109)$$

We have

$$x = \xi + (Z - l) \omega_2 \quad y = \eta + X \omega_2 - (Z - l) \omega_2 + l \theta_2 \quad z = \zeta + Y \omega_2 - X \omega_2 \quad (110)$$

and

$$\left. \begin{aligned} \frac{d^2 x}{dt^2} &= \frac{d^2 \xi}{dt^2} + (Z - l) \frac{d^2 \omega_2}{dt^2} - Y \frac{d^2 \omega_2}{dt^2} - l \frac{d^2 \theta_2}{dt^2} \\ \frac{d^2 y}{dt^2} &= \frac{d^2 \eta}{dt^2} + X \frac{d^2 \omega_2}{dt^2} - (Z - l) \frac{d^2 \omega_2}{dt^2} + l \frac{d^2 \theta_2}{dt^2} \\ \frac{d^2 z}{dt^2} &= \frac{d^2 \zeta}{dt^2} + Y \frac{d^2 \omega_2}{dt^2} - X \frac{d^2 \omega_2}{dt^2} \end{aligned} \right\} \quad (111)$$

and therefore

$$\left. \begin{aligned} F_x &= M \frac{d^2 x}{dt^2} - f_x = M \left\{ \frac{d^2 \xi}{dt^2} + (Z - l) \frac{d^2 \omega_2}{dt^2} - Y \frac{d^2 \omega_2}{dt^2} - l \frac{d^2 \theta_2}{dt^2} \right\} \\ F_y &= M \frac{d^2 y}{dt^2} - f_y = M \left\{ \frac{d^2 \eta}{dt^2} + X \frac{d^2 \omega_2}{dt^2} - (Z - l) \frac{d^2 \omega_2}{dt^2} + l \frac{d^2 \theta_2}{dt^2} - \frac{f_y}{M} \right\} \\ F_z &= M \frac{d^2 z}{dt^2} + Mg = M \left\{ \frac{d^2 \zeta}{dt^2} + Y \frac{d^2 \omega_2}{dt^2} - X \frac{d^2 \omega_2}{dt^2} + g \right\} \end{aligned} \right\} \quad (112)$$

Putting the values of the cosines from equations (108) and (109) in equation (10), we get

$$F_l = F_x \cos(\alpha + \theta_2) + F_y \sin(\theta_2) + F_z \sin(\alpha + \theta_2) \quad (113)$$

Introducing the values of  $F_x$ ,  $F_y$ , and  $F_z$  into these equations, and then the values of  $J_1$  and  $F_3$  into equation (107), and then the values of  $A$  and  $B$  thus obtained into equations (106), we get for our equations of motion

$$I_1 \frac{d^2(\theta_1 + \omega_1)}{dt^2} = Ml \left[ \left\{ \frac{d^2\xi}{dt^2} + (Z-l) \frac{d^2\omega_x}{dt^2} - Y \frac{d^2\omega_y}{dt^2} - l \frac{d^2\theta_2}{dt^2} - \frac{f_x}{M} \right\} \omega_x - \left\{ \frac{d^2\eta}{dt^2} + X \frac{d^2\omega_x}{dt^2} - (Z-l) \frac{d^2\omega_y}{dt^2} + l \frac{d^2\theta_1}{dt^2} - \frac{f_y}{M} \right\} \omega_y - \left\{ \frac{d^2\zeta}{dt^2} + Y \frac{d^2\omega_x}{dt^2} - X \frac{d^2\omega_y}{dt^2} + g \right\} (\omega_x + \theta_1) \right] + f_2(l_1 - l) \quad (114)$$

$$I_2 \frac{d^2(\theta_2 + \omega_2)}{dp} = Ml \left[ \left\{ \frac{d^2\xi}{dt^2} + (Z-l) \frac{d^2\omega_x}{dt^2} - \frac{d^2\eta}{dt^2} - l \frac{d^2\theta_2}{dt^2} - \frac{f_x}{M} \right\} \omega_x + \left\{ \frac{d^2\eta}{dt^2} + X \frac{d^2\omega_x}{dt^2} - (Z-l) \frac{d^2\omega_y}{dt^2} + l \frac{d^2\theta_1}{dt^2} - \frac{f_y}{M} \right\} \omega_y - \left\{ \frac{d^2\zeta}{dt^2} + Y \frac{d^2\omega_x}{dt^2} - X \frac{d^2\omega_y}{dt^2} + g \right\} (\omega_y + \theta_2) \right] - Mh - t \quad (115)$$

If we take the point of support as our origin, the first equation becomes (since  $X = Y = Z = 0$ , and writing  $I_a = I_x + Ml^2$ ),

$$I_a \frac{d^2\theta_1}{dt^2} = Ml \left[ \left\{ \frac{d^2\xi}{dt^2} - l \frac{d^2\theta_2}{dt^2} - \frac{f_x}{M} \right\} \omega_x - \left\{ \frac{d^2\eta}{dt^2} + g \right\} (\omega_x + \theta_1) \right] + f_2 l_1 - I_1 \frac{d^2\omega_1}{dt^2} \quad (116)$$

In this equation we have assumed that  $\nu = 1/2$ . The friction at the point of contact makes it impossible to evaluate the exact value of  $\nu$ ; it is, moreover, not large when the indicator is light; and these assumptions are always very nearly true. By omitting some of these terms as negligible and not considering the reaction of the indicator, and making the proper changes of notation, this equation becomes equation (81) of Professor Wiechert. If we take the original position of the  $CG_S$  as our origin, we have  $X=Y=Z-l=0$ ; and the equations become still simpler, namely,

$$\begin{aligned} I_{(1)} \frac{d^2\theta_1}{dt^2} &= Ml \left[ \left( \frac{d^2\xi}{dt^2} - l \frac{d^2\theta_2}{dt^2} - \frac{f_x}{M} \right) \omega_x - \left( \frac{d^2\eta}{dt^2} + g \right) (\omega_x + \theta_1) \right] + f_2 l_1 - I_1 \frac{d^2\omega_1}{dt^2} \\ I_{(2)} \frac{d^2\theta_2}{dt^2} &= Ml \left[ \left( \frac{d^2\xi}{dt^2} + \left( \frac{d^2\eta}{dt^2} + l \frac{d^2\theta_1}{dt^2} - \frac{f_x}{M} \right) \omega_x - \left( \frac{d^2\zeta}{dt^2} + g \right) (\omega_y + \theta_2) \right) - f_2 U - I_2 \frac{d^2\omega_2}{dt^2} \right] \end{aligned} \quad (117)$$

where we have also put  $j = 1$ . These equations reduce to Prince Galitzin's equation (99), on omitting certain terms and with proper changes of notation.

We can simplify further by omitting some of the terms;  $d^2\xi/dt^2$  can be neglected in comparison with  $g$ , as on page 154; the terms multiplying  $\omega_y$  represent the moment around (1) of the forces parallel with  $x$ , and have a value on account of the very small angle between them. These terms are very small in comparison with the terms not containing  $\omega_y$ , and may be omitted; omitting also the terms  $I^w/di^2$  and  $I_2 d^2 a > 2/dl^2$  for reasons given on page 154, our equations become

$$I_{(1)} \frac{d^2\theta_1}{dt^2} = -Ml \left\{ \frac{d^2\eta}{dt^2} + g(\omega_x + \theta_1) \right\} + f_2 l_1 \quad \text{with } S = Ml \left\{ \frac{d^2\eta}{dt^2} + g(\omega_x + \theta_1) \right\} - f_2 l_1 \quad (H8)$$

With these simplifications we see that the component movements of the pendulum in two directions at right angles are just the same as tho there were two simple pendulums each constrained to move in one vertical plane.

We must now substitute the values of  $\nu/2$  and  $j$  from the equations of the indicators, equation (22).

With the same assumptions made there, these equations are

$$I_{(1)} \frac{d^2\theta_1'}{dt^2} = -f_2 l_1' \quad \text{and} \quad V \frac{d^2\theta_1''}{dp} = //V \quad (119)$$

We suppose that the pivots of the indicator lie on the positive sides of the axes of  $x$  and  $y$  respectively. These equations refer to horizontal indicators with vertical axes of rotation; the primes and seconds refer to the two indicators. If, as in the Vicentini pendulum, the first multiplying lever is vertical; then  $l_{(3)'} = l_{(g)''}$ ;  $b_{s'}$  becomes 0; and  $b_{s''}$  becomes  $h_2''$ ; with these changes equations (119) still hold. Assume that  $l_{ar} = l_1$  and  $l_{j'} = l_2$ ; write  $b_{j'} = -n' b_0'' = -r_1' e_v$  where  $r_1' = l_1 l_2$  and  $r_1'' = l_1''$ ;  $Z_1'$  and  $Z_2''$  are the lengths of the short arms of the indicators. Remembering that  $l_2 = -f_2''$ , and  $l_j = -f_1''$ , and substituting in equation (118) the values of  $l_a$  and  $l_x$  from equation (119), we get

$$(J_u + n'^2 J_{(s)'}) \frac{d^2 \theta_1}{dt^2} = -Ml \left\{ \frac{d^2 \eta}{dt^2} + g(\omega_x + \theta_1) \right\} \quad (J_{(s)} + n''^2 J_{(s)''}) \frac{d^2 \theta_2}{dt^2} = JfZ \left\{ \frac{d^2 \xi}{dt^2} - g(\omega_y + \theta_2) \right\} \quad (120)$$

The second equation becomes identical with equation (23) of the horizontal pendulum if we replace  $cPO/dt^2$  by  $d^2 \xi/dt^2$ , and  $b_2$  by  $h_2''$  and shows that the actions of the two types of instruments are the same, but that, other terms in the equations being equal, the force of restitution of the horizontal pendulum is only  $i$  times as great as that of the vertical pendulum. The first equation differs only in that  $d^2 v/dt^2$  has a negative sign; this arises from the fact that a positive acceleration of  $v$  causes a negative acceleration of  $\theta_1$  whereas a positive acceleration of  $\xi$  causes a positive acceleration of  $\theta_2$ ; which is also true of the horizontal pendulum pointing in the positive direction of  $y$ . This difference causes no confusion in practice. On introducing terms for viscous damping and solid friction, we obtain equations exactly like (25) and on passing to the recording point we get equations like (26). Therefore all that has been developed regarding the horizontal pendulum — the methods of determining the constants, the magnifying power for linear displacements and tilts, and the interpretation of the record — applies equally well to the simple vertical pendulum, if we replace  $i$  by 1.

#### THE INVERTED PENDULUM.

The inverted pendulum consists of a mass balanced on a point so that its  $CG$  is vertically over the point. This position is rendered stable either by springs or by a second pendulum hanging immediately above, the two being so connected that the points of contact suffer equal displacements, and their "weights and lengths being so adjusted that the total force arising from a displacement tends to bring the system back to its original position.

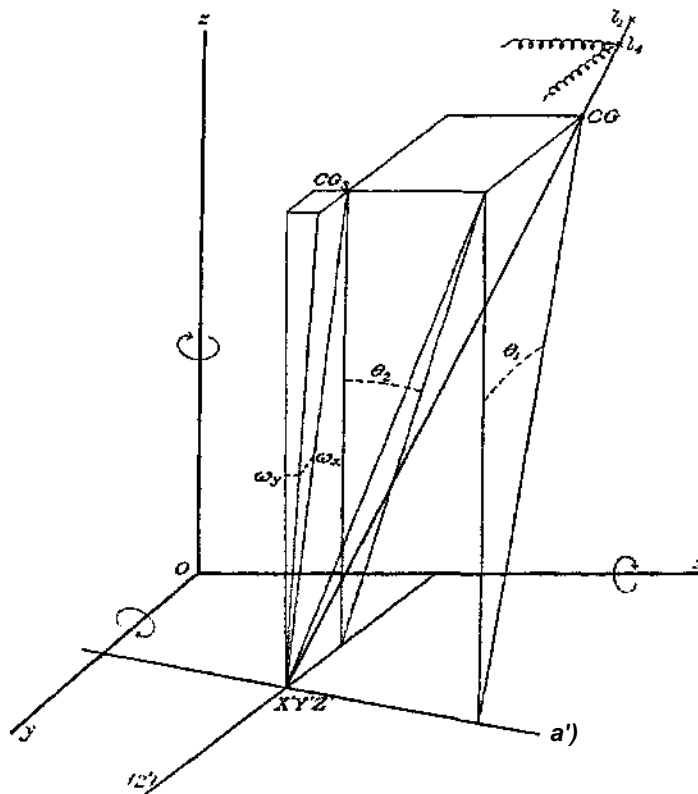

FIG. 58.

This form was originally suggested by Professor Ewing,<sup>1</sup> and the second type above mentioned is called "Ewing's duplex pendulum." A rod attached to the upper pendulum records on smoked glass through a multiplying lever, usually multiplying four times. The glass does not move and there is no arrangement for recording the time. The record of movement is superposed upon itself and is usually difficult to interpret. Several of these instruments were working at the time of the California earthquake, and their diagrams are reproduced in Seismograms, Sheet No. 3.

Lately, Professor Wiechert has greatly improved the inverted pendulum.<sup>2</sup> He has made it very heavy, 1000 kg. or more, in order that he might magnify the motion several hundred times and still not have the movement too much affected by the solid friction of the indicator. He has added a strong viscous friction so as to damp out the proper period of the pendulum and has thus produced a very efficient instrument.

To keep the pendulum in stable equilibrium, springs are attached to a point of the pendulum distant  $Z_4$  from its point of support. The forces thus introduced are proportional to the displacement; let us represent these forces brought into play by positive angular displacements,  $\delta_x$  and  $\delta_y$  around the axes (1) and (2) respectively, by  $v_1 \delta_1$  and  $-v_2 \delta_2$ ;  $v_1$  and  $v_2$  would in general have about the same values.

The equations of linear accelerations become

$$M \ddot{x} = F_x + f_x - v_2 l_2 \theta_2 \quad M \ddot{y} = F_y + f_y + v_1 l_1 \theta_1 \quad M \ddot{z} = F_z - Mg \quad (121)$$

The moments become

$$A = F_2 l_2 - Mk - T - uM(I, -I) \quad J_3 = -FJ + A(I, -I) - V\delta_2 (J_4 - V) \quad (122)$$

The cosines of the angles between the moving and fixed axes are the same as for the vertical pendulum, equations (108) and (109). The values of the coördinates of the *CG* ( $x, y, z$ ) are also the same as those given in equation (110), with the sign of  $I$  reversed. Carrying thru the same operations as before, making the original position of the *CG* the origin of coördinates and omitting the negligible terms, we arrive at the equations

$$\begin{aligned} I_{(1)} \frac{d^2 \theta_1}{dt^2} &= Ml \left\{ \frac{d^2 \xi}{dt^2} + g \omega_x - \left( \frac{v_1 l_1^2}{Ml} - g \right) \theta_1 \right\} - f_2 l_1 \\ I_{(2)} \frac{d^2 \theta_2}{dt^2} &= -Ml \left\{ \frac{d^2 \xi}{dt^2} - g \omega_y + \left( \frac{v_2 l_2^2}{Ml} - g \right) \theta_2 \right\} + f_1 l_1 \end{aligned} \quad (123)$$

If there is no disturbance  $d^2 y/dt^2$ ,  $d^2 \xi/dt^2$ ,  $\omega_x$  and  $\omega_y$  are all zero, and in order that the equilibrium should be stable, we must have  $v_1 l_1^2/Ml > g$ , and  $v_2 l_2^2/Ml > g$ . Introducing the values of  $f_x$  and  $f_y$  from equations (119), dividing by  $[I_{(1)}]$ ,  $[I_{(2)}]$ , and writing  $[I_{(1)}]/Ml = L_1$ ,  $[I_{(2)}]/Ml = L_2$ , we find

$$L_1 \frac{d^2 \theta_1}{dt^2} + \left( \frac{v_1 l_1^2}{Ml} - g \right) \theta_1 = f_2 \frac{l_1}{L_1} \quad L_2 \frac{d^2 \theta_2}{dt^2} - \left( \frac{v_2 l_2^2}{Ml} - g \right) \theta_2 = f_1 \frac{l_2}{L_2} \quad (124)$$

After adding damping and frictional terms to these equations, they differ from equation (25) only in some of the signs (which is a matter of notation), and in the factor multiplying the angular displacement. If we replace  $(v_1 l_1^2/Ml - g)/g$  of equations (124) by  $i$  they become equivalent to equation (25), and on passing to the marking points, we get equations equivalent to (26). Therefore all the characteristics of the horizontal pendulum and the interpretation of its record may be applied to the inverted pendulum if we suppose  $i$  in the former to be replaced by  $(v_1 l_1^2/Ml - g)/g$ .

<sup>1</sup> Transactions Seismological Society of Japan, 1882, vol. V, p. 89; and 1883, vol. VI, p. 19.

\* Ein astatische Pendel hoher Empfindlichkeit zur mechanischen Registrierung von Erdbeben. E. Wiechert, Gerland's Beiträge zur Geophysik, 1904, vol. VI, pp. 435-450.

## SEISMOGRAPHS FOR VERTICAL MOVEMENTS.

The older Italian form of instrument for showing vertical movements was simply a weight hung by a spiral spring, which would be set in motion by any vertical movement of the earth. Palmieri arranged it so that a very small displacement was sufficient to close an electric circuit and thus record a disturbance. Cavalleri added a magnifying lever, which measured the movement of the weight. However, the period of such an instrument would be short unless the spring were inordinately long, and a second form has been devised to obtain a larger period in a smaller compass. This consists of a horizontal bar, pivoted at one end and carrying a weight at the other; it is supported by a spring attached to an intermediate point of the bar.

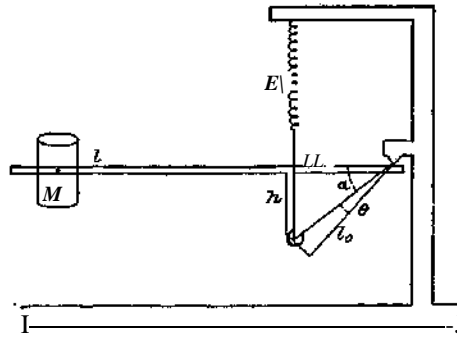

FIG. 59.

This form of instrument was devised by Thomas Gray.<sup>1</sup> Professor Ewing<sup>2</sup> suggested that the point of support of the spring be below the bar, thus increasing the period for a given strength of spring.

Let  $E$  be the force of the spring when the pendulum is at rest; and let  $p$  be the variation of this force for a unit stretch of the spring; then for equilibrium (see figure 59),

$$fl_A - Mgl = 0 \quad \text{or} \quad El_0 \cos a - Mgl = 0 \quad (125)$$

and when the pendulum is displaced thru an angle  $\theta$  the additional moment will be

$$\frac{d}{da} (El_0 \cos a) \theta = k \frac{dh}{da} B - El_0 \sin a \cdot \theta = (pU - Eh) \theta \quad (126)$$

and the free period of vibration will be

$$T_0 = 2\pi \sqrt{\frac{I}{pZ^2 - Eh}} = 2\pi \sqrt{\frac{I}{h}(ph^3 - Mglh)} \quad (127)$$

We can therefore make the period as long as we choose by selecting suitable values of  $p$ ,  $l$ ,  $M$ ,  $I$ , and  $h$ .

The next modification for increasing the period of the pendulum is described by Prof. John Milne.<sup>3</sup> The supporting spring is a curved flat steel band; and the compensation is obtained by a special spring fastened immediately above the pivot to an arm connected rigidly with the bar of the pendulum. As long as the pendulum is at rest this spring has no effect, but when the bar is raised or lowered, the spring exerts a moment tending to increase the displacement; this is equivalent to reducing the force of restitution due to the main supporting spring, and therefore increases the period of the pendulum. The principle here made use of seems to have been first suggested by Professor Ewing.\* Let

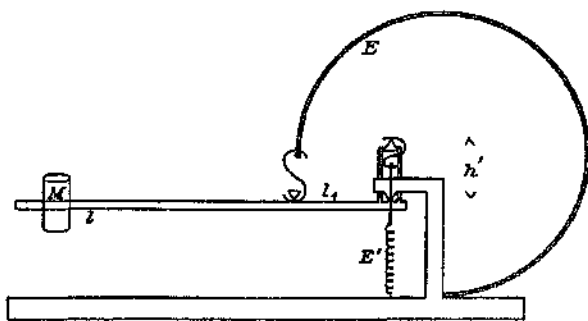

Fig. 60.

<sup>1</sup> On a Seismograph for Registering Vertical Motion, Trans. Seism. Soc. Japan, 1881, vol. Hi, p. 137.

<sup>2</sup> Similar form is reported to have been used at Comrie, Scotland, in 1841.

<sup>3</sup> A Seismometer for Vertical Motion. Same, p. 140.

\* The Gray-Milne Seismograph, etc. Same, 1888, vol. xii, pp. 33-48.

\* Same, 1881, vol. fii, p. 147.



$E'$  be the force of the compensating spring and let  $h'$  be the length of the arm measured from the knife-edge. When the pendulum is displaced thru an angle  $\theta$ , the moment of the forces of restitution becomes

$$-\frac{MM}{da} \frac{dEh}{dt} (\theta) = -E'h'\theta \quad (128)$$

and the period of free vibration is

$$T_0 = 2\pi \sqrt{\frac{I}{Mgh'}} \quad (129)$$

If the pendulum points in the positive direction of  $y$ , it only records relative deflections around the axis (1). To find the equation of motion of these instruments when subjected to a disturbance, we proceed as in the former cases. For the last-described instrument, using the same notation as heretofore, we

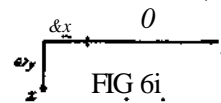

FIG 6i

equation of linear displacement of the CG,

$$M \frac{d^2x}{dt^2} = F_x - Mg + (E - \rho l \theta) - E' \quad (130)$$

The cosines of the angles between the fixed axes and axis (3) are (figure 61)

$$\cos(\alpha, 3) = -a, \quad \cos(y, 3) = -(a_x + 0) \quad \cos(z, 3) = 1 \quad (131)$$

and the general equation of angular acceleration around axis (1) becomes

$$\frac{d^2\theta}{dt^2} = \frac{1}{L} \left\{ \left( \frac{d^2\xi}{dt^2} + Z \frac{d^2\omega_y}{dt^2} - (Y+l) \frac{d^2\omega_y}{dt^2} \right) \omega_y + \left( \frac{d^2\eta}{dt^2} + X \frac{d^2\omega_x}{dt^2} - Z \frac{d^2\omega_x}{dt^2} - \frac{f_y}{M} \right) (\omega_x + \theta) - \left( \frac{d^2\xi}{dt^2} + (Y+l) \frac{d^2\omega_x}{dt^2} - X \frac{d^2\omega_y}{dt^2} \right) \right\} - \frac{(\rho l^2 - E'h')\theta}{[I]} - \frac{I_1}{[I]} \frac{d^2\omega_1}{dt^2} \quad (132)$$

The weight  $Mg$  has been eliminated through equation (125). If we make the  $CG_0$  the origin of coördinates, omit the negligible terms, and add terms for viscous damping and solid friction, the equation becomes

$$\frac{d^2c}{dt^2} + 2\kappa \frac{dc}{dt} + n^2c - \frac{n^2}{L} \frac{d^2\xi}{dt^2} = p' = 0 \quad (133)$$

If we had used the Ewing form of attaching the spring to a point below the bar we should have obtained a similar equation with  $E$  and  $h$  substituted for  $E'$  and  $h'$ . The indicator equation becomes, writing  $n^2$  for  $(2 \text{ Tr}/T)^2$ , or  $\{p_1^2 - E'h'\}/[I]$ ,

$$\frac{d^2c}{dt^2} + 2\kappa \frac{dc}{dt} + n^2c - \frac{n^2}{L} \frac{d^2\xi}{dt^2} = p' = 0 \quad (134)$$

where  $c$  is the recorded displacement of the marking point. These 2 equations are entirely similar to equations (25) and (26) for the horizontal pendulum, except that they do not contain a rotation. The physical explanation of this is that the position of equilibrium of the horizontal pendulum *relative to the support* is altered by the rotation  $\alpha$ , but that of the vertical motion pendulum is practically unaffected by a small rotation about any axis. If we place our origin at the  $CG_0$ , the only term in the general equation (132), containing the angular acceleration about (1), is  $(/[I])c^2/dt^2$ , which corresponds to the term we considered on page 158 for the horizontal pendulum. The factor  $/[I]$  will in general be small; for a beam carrying a brass sphere 10 cm. in diameter, at a distance of 40 cm. from the axis of rotation, it would not be as much as  $5 \times 10^{-5}$  and since  $cPw^2/dt^2$  is, in general, much less than  $d^2\theta/dt^2$ , the motion of these instruments is only affected to an entirely negligible extent by a rotation around the  $CG_0$ .

The form of instrument in most general use for recording vertical motion is that developed by Professor Vicentini of Padua,<sup>1</sup> though the principle seems to have been used in Comrie, Scotland, in 1841.<sup>2</sup> It consists of a heavy mass supported by an elastic rod so that it vibrates in a vertical plane, and records by means of multiplying levers on smoked paper. Usually there is no damping. The complete theory of this instrument is that of a weighted elastic rod, and is very complicated. It has several proper periods of vibration, and it would be set in vertical motion by a horizontal displacement in the direction in which it points. We can, however, develop an approximate theory which

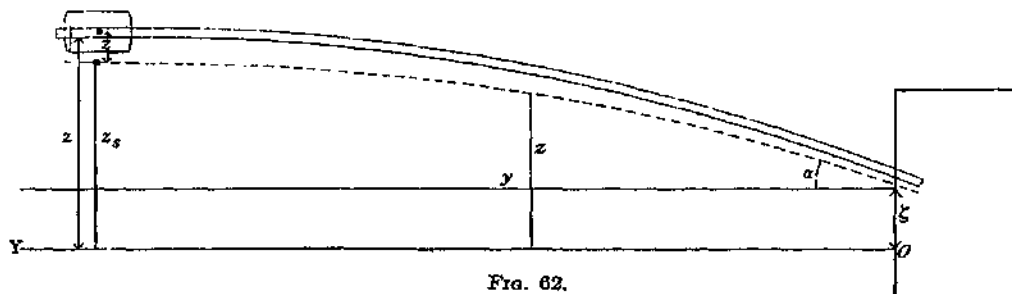

is quite simple. Let the instrument point in the positive direction of  $y$  and let  $z$  be positive upwards; see figure 62. Take the origin  $O$ , at a distance  $K$  below the point where the rod is supported. Later,  $\xi$  will be considered the vertical displacement of the support. Let  $l$  be the length of the rod,  $I$  the so-called moment of inertia of its cross-section, which we consider constant;  $E$  Young's modulus for the material of the rod,  $M$  the mass at its end, and  $M'$  an arbitrary mass. If we consider the bar but slightly bent, its curvature will be represented by  $d^2z/dy^2$ ; and we have from the general theory of a loaded cantilever, neglecting the weight of the rod,

$$EJcPz/dy^2 = -M'g(I - y) \quad (135)$$

Integrate this equation twice, and determine the constants of integration by the conditions that  $dz/dy = a$ , and  $z = \xi$ , when  $y = 0$ ; we get the equation

$$6EJ(z - \xi - ay) = -M'g(3I - 2fy) \quad (136)$$

where  $z$  refers to the point on the bar whose abscissa is  $y$ . For the  $CG$  of  $M'$ ,  $y = l$ , and letting  $z$  now represent the ordinate of this point, we get

$$6EJ(z - \xi - \alpha l) = 2M'g\alpha l \quad (137)$$

which gives us the ordinate of the  $CG$  when it is at rest, the mass being supported by the slightly bent rod.

To determine the acceleration when the weight is not at rest, we may replace  $M'$  by  $M + Mj$ ; and by d'Alembert's principle, equation (137) will still hold when we replace  $M'g$  by the force  $[M]d^2z/dt^2$ , where  $d^2z/dt^2$  is the acceleration of the  $CG$  and where  $[M] = M + (7' + n_2^2 / \dots) / l^2$  is the effective mass of  $M$  and the multiplying levers; this is analogous to the value of  $[I]$  determined on page 155 and can be found in the same way by the consideration of the reactions of the multiplying levers. On making these substitutions we get for the equation of the moving  $CG$  in absolute coördinates

$$6EJ(z - l - \alpha l) = -2Mgf - 2[M]l \frac{d^2z}{dt^2} \quad (137a)$$

<sup>1</sup> Microsismographo per la componente verticali, G. Vicentini e G. Faefaer. Boll. Soc. Sismologica Italiana, 1899-1900, vol. V, pp. 33-58.  
<sup>2</sup> British Assoc. Report, 1842, p. 64.

Writing  $z_s$  for the ordinate of the  $CG_0$  when at rest and the mass at the end of the rod is  $M$ , we get from (137)

$$6 EJ(z_s - \xi - cd) = -2 Mgf$$

The last two equations give by subtraction

$$z - z_s = \frac{[M]l^3}{3EJ} \left( \frac{d^2 z'}{dt^2} + \frac{d^2 \xi}{dt^2} \right) \quad (138)$$

$z$  is the absolute ordinate of the  $CG$ ,  $z_s$  of the  $CG_0$ ; and  $z_s - K$  is the ordinate of the  $CG_0$  relative to the support. If the support vibrates under the action of earthquake waves,  $K$  will vary. In order to express the displacement in terms of the motion of the  $CG$  relative to the  $CG_0$  we must move our origin to  $z_s$ ,  $l$ , and call the displacement of the  $CG$  from this point  $z'$ ; that is, we substitute  $z - z_s = z'$ , and since  $z_s - K$  is constant when  $\xi$  is varying under the vertical movement of the support,  $d^2 z_s / dt^2 = d^2 Z / dt^2$ ; we get

$$z' = - \frac{[M]l^3}{3EJ} \left( \frac{d^2 z'}{dt^2} + \frac{d^2 \xi}{dt^2} \right) \quad (139)$$

Introducing damping and frictional terms, and putting  $3 EJ/[M]l^3 = (2\pi/7)^2 = n^2$ , this may be written

$$\frac{d^2 z'}{dt^2} + 2\kappa \frac{dz'}{dt} + n^2 z' + \frac{d^2 \xi}{dt^2} \pm p_0 = 0 \quad (140)$$

For the equation of the marking point we multiply by  $m = \rho A l$ ; and since  $c$ , the displacement of the marking point equals  $mz'$ , we get

$$\frac{d^2 c}{dt^2} + 2\kappa \frac{dc}{dt} + n^2 c - \bar{m} \frac{d^2 \xi}{dt^2} \mp p' = 0 \quad (141)$$

which is entirely similar to the equations of the other forms of vertical motion instruments.

As we have only considered linear displacements, the position of the origin of coördinates is unimportant; but if a rotation occurs, it must be considered. A rotation around the  $CG_0$  as origin would evidently have no effect, if we neglect the moment of inertia of the mass about its  $CG$ , as we have done. But an angular acceleration  $d^2 a > J dt^2$  around an axis through  $O$  at right angles to the paper would make  $z_s - K - c o j$  instead of  $z_s - K$  constant during the motion and would therefore add a term  $l d^2 a j dt^2$  to (140) and  $\bar{m} l d c o j dt^2$  to (141). These terms in general would probably be unimportant.

We see thus that the approximate equations of all forms of seismographs referred to the  $CG_0$  are of the same general form; except that no rotation is present in the equations of the vertical motion instruments. The formulas (79a) and (81) are applicable to them all to determine their magnifying powers.

#### SEPARATION OF LINEAR DISPLACEMENTS AND TILTS.

A rigid body can be moved from one position in a plane to any other by means of a linear displacement and a rotation; altho the direction of the axis of the rotation and the amount of the rotation are determined by the two positions of the body, the distance of the axis is not; we can choose this distance arbitrarily and then determine the linear displacement to correspond; and the total displacement of a point of the body will be the displacement due to the rotation around the axis plus the linear displacement of the axis; as the rotation is independent of the distance of the axis, the nearer the latter is to the body, the greater will be the displacement due to the displacement of the axis and the less will be that due to rotation; and there is one distance of the axis for which all the displacement may be expressed as a rotation. We see therefore the origin of the difficulty

in separating displacements and rotations; for their relative effects in producing movements of the seismograph depend on the arbitrary choice of the axis for the rotation. This appears in equation (16), where the values of the various coefficients depend on the choice of the origin of coördinates, about which the rotations are supposed to take place.

If we could get rid of the effects of linear displacements, we could determine the rotations. This was first done by Professor Milne<sup>1</sup> who supported a beam by knife-edges at its center of gravity; and later by Dr. Schliiter.<sup>2</sup> These instruments failed to show any tilts at the times of the earthquakes, which therefore must be extremely small.

A second method of determining tilts has been proposed by Professor Wiechert.<sup>3</sup> Let two horizontal pendulums with equal values of  $K$ ,  $ril/L$  and  $gi/L$  be installed, one vertically over the other; and let the origin of coördinates be chosen at the  $CGQ$  of the lower pendulum; its equation will be

$$\frac{d^2 a_1}{dt^2} + 2K \frac{da_1}{dt} - \frac{\bar{n}l}{L} \frac{d^2 \xi}{dt^2} + \frac{\bar{n}l\omega_0}{L} \xi = 0 \quad (25)$$

the equation of the upper pendulum will be

$$\frac{d^2 a_1}{dt^2} + 2K \frac{da_1}{dt} - \frac{\bar{n}l}{L} \frac{d^2 \xi}{dt^2} - \frac{\bar{n}lZ'}{L} \frac{d^2 \xi}{dt^2} + \frac{\bar{n}l\omega_0}{L} \xi - \frac{\bar{n}lZ'}{L} \xi = 0 \quad (142)$$

it contains an extra term  $-\frac{\bar{n}lZ'}{L} \frac{d^2 \xi}{dt^2}$  where  $Z' = Z - il$  is, in this case, the distance between the centers of gravity of the 2 pendulums; the origin of this term will appear on referring to equation (16). On taking the difference of these two equations we get

$$\frac{d^2 (a_2 - a_1)}{dt^2} + 2K \frac{d(a_2 - a_1)}{dt} - \frac{\bar{n}lZ'}{L} \frac{d^2 \xi}{dt^2} + \frac{\bar{n}l\omega_0}{L} \xi - \frac{\bar{n}lZ'}{L} \xi = 0 \quad (143)$$

which gives us a relation between the record and the angular acceleration of the earth about the axis of  $y$  without containing the linear displacement. If we work out the value of  $co_y$  and substitute it in equation (25) we can then find the linear acceleration. Prince Galitzin has shown a very elegant manner of carrying out this process by the use of his method of electromagnetic recording thru a galvanometer.<sup>4</sup> Professor Wiechert's method presupposes that the supports of the 2 pendulums move as tho they were parts of a rigid body, and therefore that the motions can be represented as the same rotation about the same axis. This would certainly not be the case if the upper instrument were mounted in a high building, for then the vibrations of the building would interfere; and it may be questioned whether the condition would hold for two points at different distances below the surface of the earth. But if two pendulums are mounted, one above the other on the same support, as Prince Galitzin arranged them in his experiments, these objections disappear.

A similar method can be applied to vertical motion instruments; let us suppose that two similar instruments are mounted close together with their axes of rotation in the same straight line, but with their beams pointing in opposite directions; it is evident that any vertical displacement would affect them alike, but a rotation around their common axis of rotation would cause movements in opposite directions. The equations of the two

<sup>1</sup> British Assoc. Reports, 1R92.

<sup>2</sup> Schwingungsart und Weg der Erdoberfläche. Gerland's Beiträge zur Geophysik, 1903, vol. V, pp. 314-359, 401-465.

<sup>3</sup> Principien für die Beurteilung der Wirksamkeit von Seismographen. Verhand. 1<sup>8to</sup> Intern. Seismol. Konferenz. Geol. und Bergbau zur Geophysik, Ergänzungsband I, pp. 264-280.

\* Ueber die Methode zur Beobachtung von Neigungswellen. Acad. Imp. des Sciences St. Petersburg. C. R. Com. Perm. Sfaraique, 1905, T. II, Liv. II, pp. 1-144.

instruments would be, on putting the origin of coördinates at the axis of rotation (see equations (132) and (134)),

$$\left. \begin{aligned} & \frac{d^2c_1}{dt^2} - 2\kappa \frac{dc_1}{dt} + n^2c_1 - \frac{nl}{L} \frac{d^2\theta}{dt^2} - \frac{nM}{L} \frac{d\theta}{dt} - \frac{nl}{L} \frac{d^2\omega}{dt^2} - \frac{nM}{L} \frac{d\omega}{dt} - p_1' = 0 \\ \text{and} & \frac{d^2c_2}{dt^2} + 2\kappa \frac{dc_2}{dt} + n^2c_2 - \frac{nl}{L} \frac{d^2\theta}{dt^2} + \frac{nM}{L} \frac{d\theta}{dt} - \frac{nl}{L} \frac{d^2\omega}{dt^2} + \frac{nM}{L} \frac{d\omega}{dt} - p_2' = 0 \end{aligned} \right\} \quad (144)$$

on adding these two equations, the tilt disappears; and on subtracting one from the other, the vertical linear displacement disappears. The two instruments record the displacement and rotation of the same point, and therefore the separation of these two involves no supposition as to the motions of points at some distance apart.

Prince Galitzin has described another method of measuring comparatively rapid tilts. He has shown that a bar hung by wires of equal length, attached to its ends, the wires themselves being fastened to the support at different heights, so that the bar hangs in an inclined position, will be rotated around a vertical plane by a tilt at right angles to the plane of the wires, and this rotation will not be affected by the swinging of the bar as a pendulum. This is a modification of the bifilar pendulum, designed by Mr. Horace Darwin for the study of slow earth-tilts.<sup>1</sup>

<sup>1</sup> See C. Davison, Bifilar Pendulum for Measuring Earth-Tilts. Nature, 1894, vol. L, pp. 246-249.

DEFINITIONS.

$\xi, r_j, \xi$ , linear displacements of the ground.	$M$ , mass of the pendulum.
$\omega$ , rotation of the ground.	$I$ , distance of <i>CG</i> from the axis of rotation.
$P$ , period of linear displacements of the ground.	$L = [I - \sqrt{MI}]$ , distance of center of oscillation from axis of rotation.
$Q$ , period of rotations of the ground.	$i$ , inclination of axis of rotation to the vertical.
$p = 2\pi r/P$	$U = L/i$ , length of simple mathematical pendulum having the same period.
$T$ , period of the pendulum with damping.	$K$ , coefficient of viscous damping.
$T_o$ , period of the pendulum without damping.	$1/K$ , relaxation time, that is, the time required for the amplitude to diminish in the proportion 1: $1/e$ .
$T_v$ , period of the pendulum without damping when swung vertically.	$c$ , damping ratio.
$CG$ , center of gravity of the pendulum at any time.	$A$ , logarithmic decrement.
$CG_o$ , center of gravity of the pendulum when at rest.	$r$ , frictional displacement of medial line.
$CG_{,,}$ , center of gravity of the pendulum supposed rigidly connected with the support and moving with it.	$a$ , amplitude of the recording point.
$J_i$ , moment of inertia of the pendulum about <i>CG</i> .	$A$ , range of the recording point.
$J_{(1)}$ , moment of inertia of the pendulum about axis of rotation.	$V$ , magnifying power for rapid linear harmonic displacements.
$[/]$ , complete moment of inertia about axis of rotation, including the magnifying levers.	$W$ , magnifying power for linear harmonic displacements of any period.
	$U$ , magnifying power for harmonic rotations of any period.

USEFUL FORMULAE.

$$i = T_v > T_0^* \quad (34)$$

$$\frac{g^i}{L} = \frac{g}{V} = \left(\frac{2\pi}{T_0}\right)^2 \quad (38)$$

$$T_0 = \frac{T}{\sqrt{1 + (\kappa T/2\pi)^2}} \quad (38a)$$

$$T_0 = T \sqrt{1 - (KT/2 - n)^2} \text{ when } \kappa \text{ is small} \quad (39)$$

$$\left(\frac{\kappa T_0}{2\pi}\right)^2 = \left(\frac{\kappa T}{2\pi}\right)^2 / \left\{1 + \left(\frac{\kappa T}{2\pi}\right)^2\right\}$$

$$\left(\frac{\kappa T_0}{2\pi}\right)^2 = \frac{\log^2 \epsilon}{7y} = \frac{\log^2 \epsilon}{1.862 + \log^2 \epsilon} \quad (44)$$

$\frac{KT}{2\pi} = \frac{\Delta}{\pi} = \frac{0.733}{n} \log \epsilon^n$

$$\frac{1}{\kappa} = \frac{T}{2\Delta} \text{ from} \quad (44)$$

$$\epsilon^n = \frac{A_1 - A_{n+1}}{A_{n+1} - A_{2n+1}} \quad (54)$$

$$2r = \frac{A_2^2 - A_1 A_3}{A_1 - A_3} \quad (52)$$

$$2r = \frac{\epsilon - 1}{\epsilon + 1} \frac{A_{n+1}^2 - A_1 A_{2n+1}}{(A_1 - A_{n+1}) - W_{n+1} - A_{n+1}} \quad (57)$$

$$\kappa = \frac{4.605}{nT} \log \frac{A_1 - A_{n+1}}{A_{n+1} - A_{2n+1}} \quad (56)$$

$$W = \frac{V}{JA \frac{\log^2 \epsilon}{1.862 + \log^2 \epsilon} \left(\frac{2y}{T_0}\right) + \left\{\left(\frac{PV}{T_0}\right) - iT\right\}} \quad (79a)$$

$$W = \sqrt{4 \left(\frac{\kappa T_0}{2\pi}\right)^2 \left(\frac{P}{T_0}\right) + \left\{\left(\frac{P}{T_0}\right) - 1\right\}^2} + 4 \left(\frac{\kappa T_0}{2\pi}\right) \left(\frac{P}{T_0}\right) \left(\frac{4r}{\pi a}\right) \left(\frac{P}{T_0}\right) + \left(\frac{4r}{\pi a}\right)^2 \left(\frac{P}{T_0}\right)^2 \quad (81)$$

$$U = \frac{\bar{n}}{i} \frac{Y}{\sqrt{4 \frac{\log^2 \epsilon}{1.862 + \log^2 \epsilon} \left(\frac{Q}{T_0}\right)^2 + \left\{\left(\frac{Q}{T_0}\right) - 1\right\}^2}} \quad (91)$$

$$F = \frac{\bar{n}}{i} = \frac{\bar{n}f}{L} = a/L \quad (29) \text{ and } (33)$$

where  $a_a$  is the displacement of the pointer corresponding to an angular displacement  $\delta$  of the pendulum.